



Enabling Additive Manufacturing Technologies for Advanced Aero Propulsion Materials & Components

Michael C. Halbig¹ and Mrityunjay Singh²

1-NASA Glenn Research Center, Cleveland, OH

2-Ohio Aerospace Institute, Cleveland, OH

**Pacific Rim Conference of Ceramic Societies, PACRIM13
Okinawa, Japan, Oct. 27-31, 2019.**

Outline



- Background, Applications, and NASA Strategic Thrusts
- AM of CMCs and Polymer Materials for Turbine Engine Applications
 - Laminated Object Manufacturing (LOM) for continuous fiber composites
 - Binder Jet Printing for short fiber composites
 - FDM of polymer-based materials
- AM of Materials and Components for Electric Motors
 - CAMIEM intro: the objectives and approach
 - New component designs for integration into the motor
 - Direct writing of conductors
 - Fabrication and evaluation of a baseline motor
- Summary and next steps

Additive Manufacturing Technologies

Direct Write Printing

Controlled dispensing of inks, pastes, and slurries.

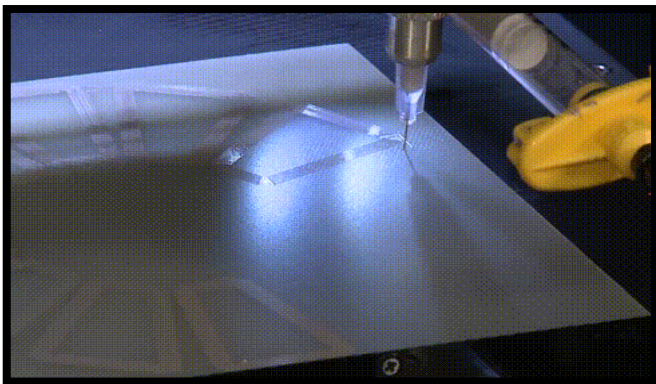
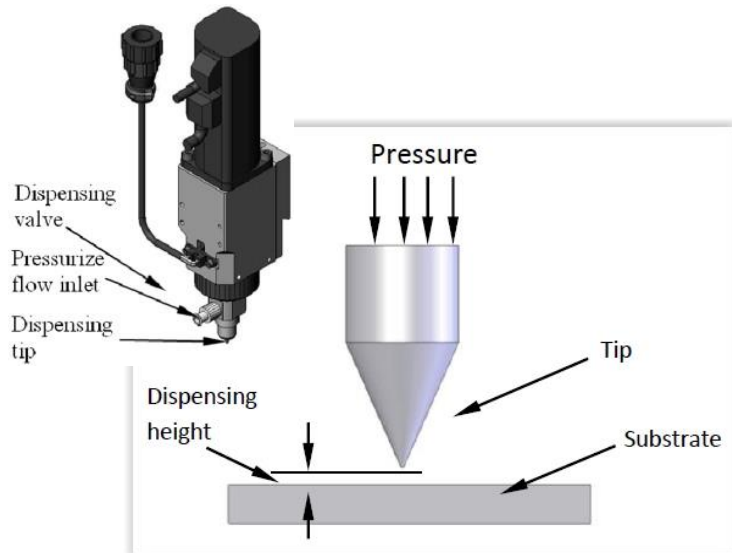

Fused Deposition Modeling

Plastic is heated and supplied through an extrusion nozzle and deposited.

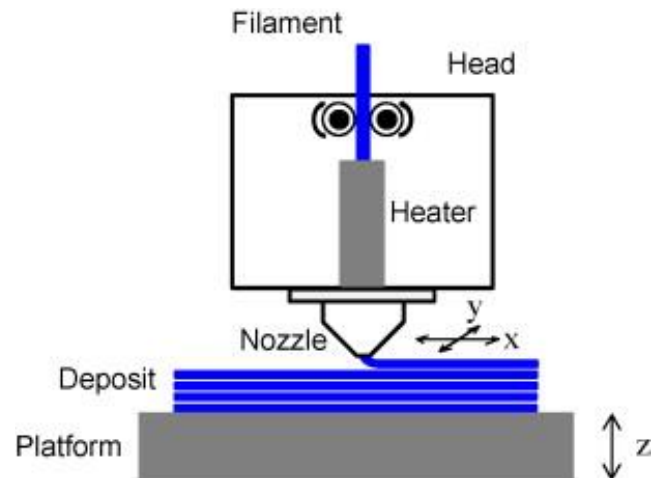

Binder Jetting

An inkjet-like printing head moves across a bed of powder and deposits a liquid binding material.

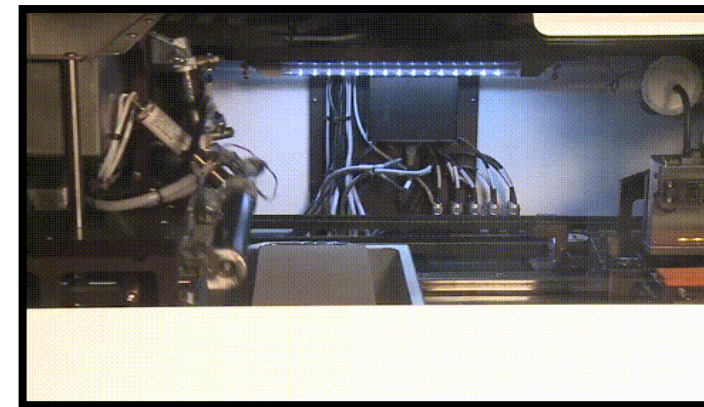
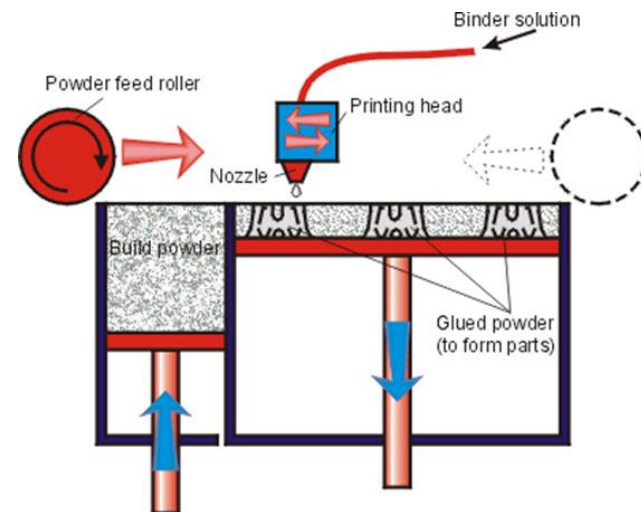

Components for Turbine Engine Applications

NASA CMC Components from Conventional Fabrication Methods

Turbine Engines - Targeted Components (CMCs and PMCs)

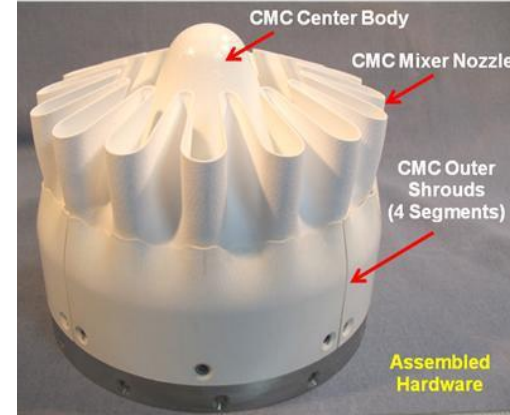
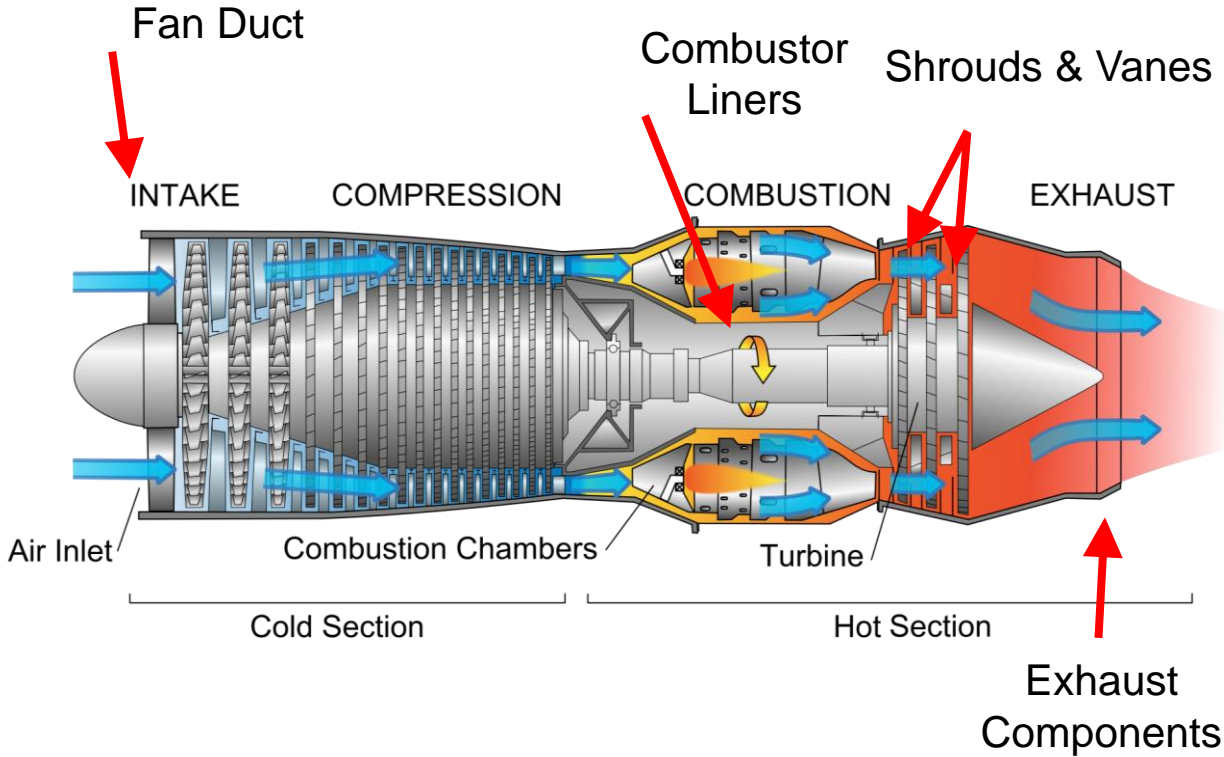

Oxide/Oxide Mixer Nozzle

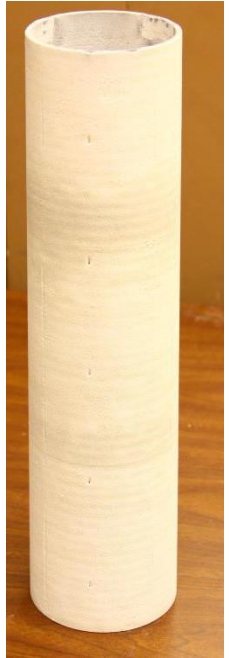

SiC/SiC Combustion Liners: Outer Liner and EBC Coated Inner Liner

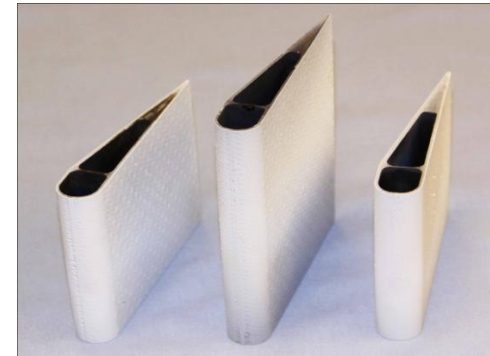

EBC Coated SiC/SiC Vanes



Components for Electric Motor Applications

Electric Motors- Targeted Components (structural, functional, and electrical)

Axial Flux Machine

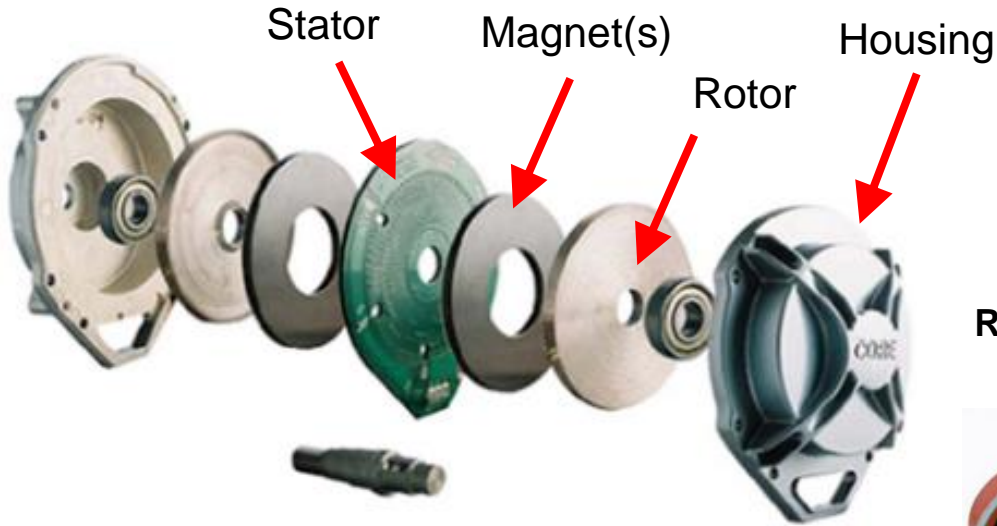

Radial Flux Machine



Electrified Aircraft



NASA 15-PAX tiltwing aircraft

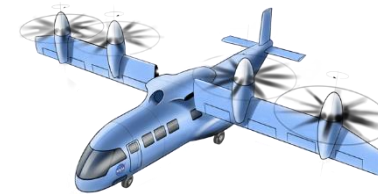

Uber Elevate



NASA Aeronautics Research Six Strategic Thrusts



3.



Ultra-Efficient Commercial Vehicles

- Pioneer technologies for big leaps in efficiency and environmental performance

4.



Transition to Low-Carbon Propulsion

- Characterize drop-in alternative fuels and pioneer low-carbon propulsion technology

Achieve and exceed N+2 and N+3 goals for increased efficiencies and reduced emissions.

Laminated Object Manufacturing For Silicon Carbide-Based Composites

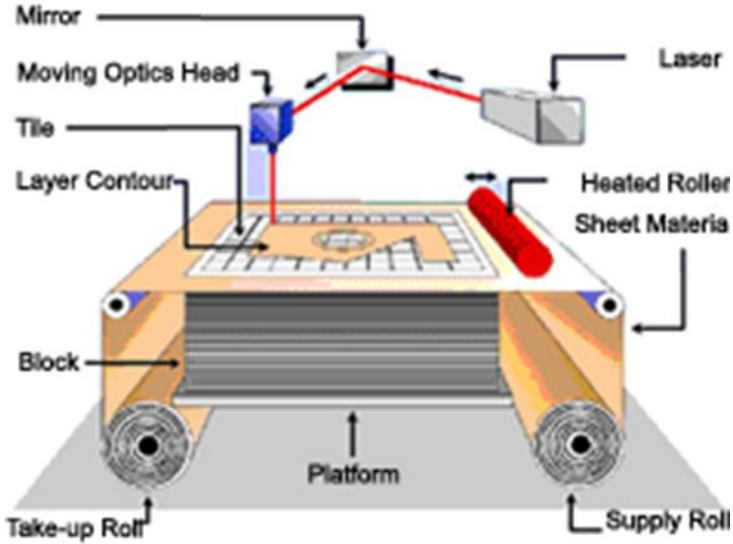

Universal Laser System (Two 60 watt laser heads and a work area of 32"x18")

Prepregs for Composite Processing

- A number of SiC (Hi-Nicalon S, uncoated) fabrics (~6"x6") were prepregged.
- These prepregs were used for optimization of laser cutting process.
- Baseline laser cutting data was also generated for different types of SiC fabrics (CG Nicalon, Hi-Nicalon, and Hi-Nicalon S)

LOM allows for continuous fiber reinforced CMCs.



SEM specimens cut with different laser power/speeds

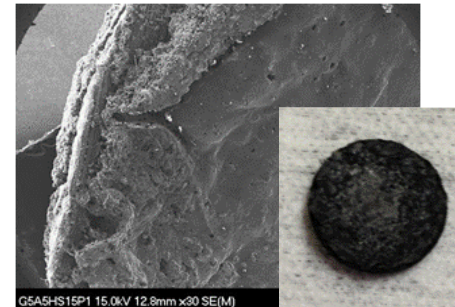
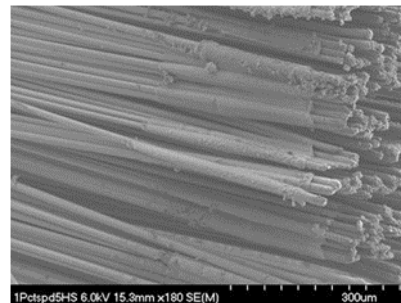

Fabrics and Prepregs cut at different laser powers/speeds

Laser cut prepregs used for composite processing

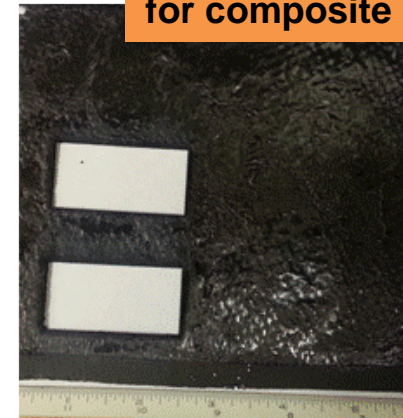

Microstructure of SiC/SiC Composites Fabricated Using Single Step Reaction Forming Process plus Si Infiltration

Fibers Used for Prepregs: SiC (Hi-Nicalon S Fibers, 5 HS weave)

Fiber Interface Coating: None

Prepreg Composition: Prepreg 5A Nano 2 + Si

Green Preforms:

8 layers of prepregs; warm pressed @75-85°C

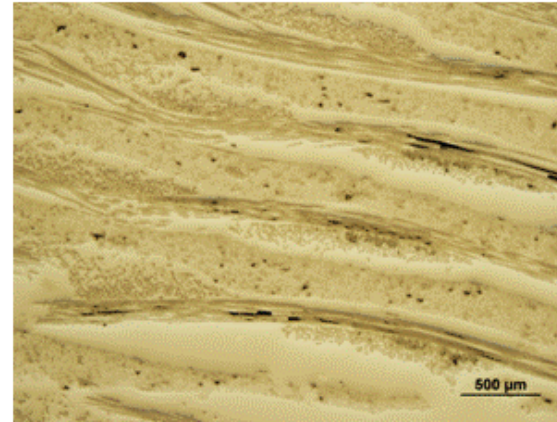

Heat Treatment:

1475°C, 30 minutes
in vacuum

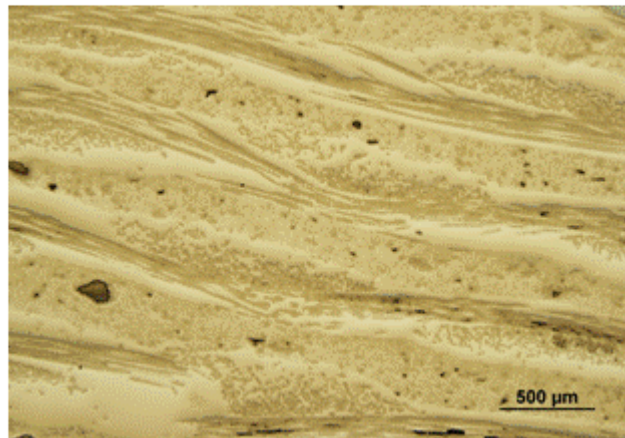

- Dense matrix after silicon infiltration. However, uncoated fibers are damaged due to exothermic Si+C reaction.
- Fiber coatings needed to prevent silicon reaction and provide weak interface for debonding and composite toughness.

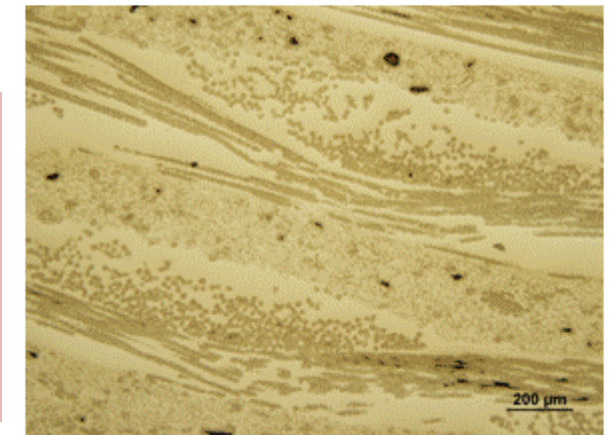

Microstructure of SiC/SiC Composites Fabricated Using Single Step Reaction Forming Process plus Si Infiltration

Fibers Used for Prepregs: SiC (Hi-Nicalon S Fibers, 5 HS weave)

Fiber Coating: None

Prepreg Composition: Prepreg 5A Nano 2 + Si

Green Preforms:
8 layers of prepregs; warm pressed @75-85°C

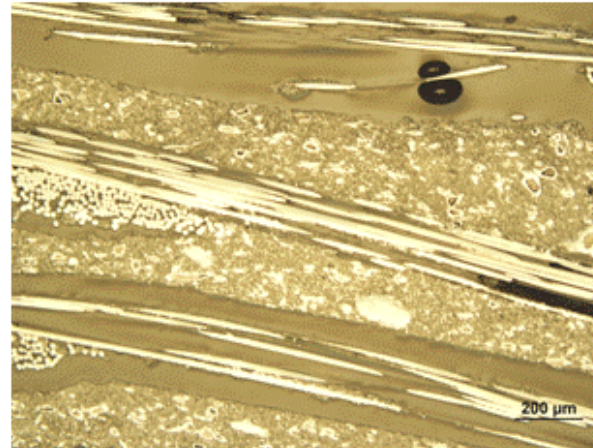

Heat Treatment:
1475°C, 30 minutes
in vacuum

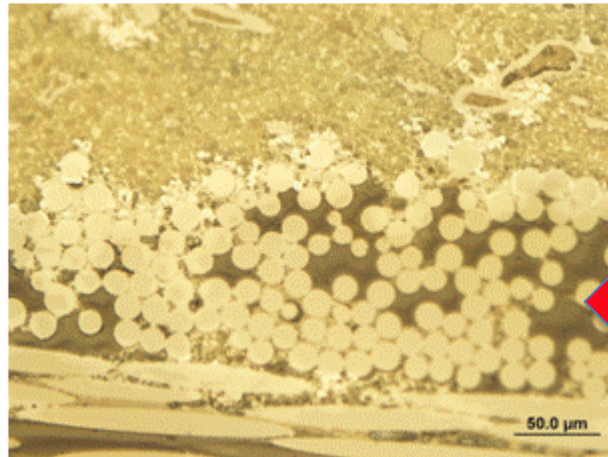

Micrographs show good distribution of SiC and Si phases.

Uncoated SiC fibers show no visible damage due to Si exothermic reaction.

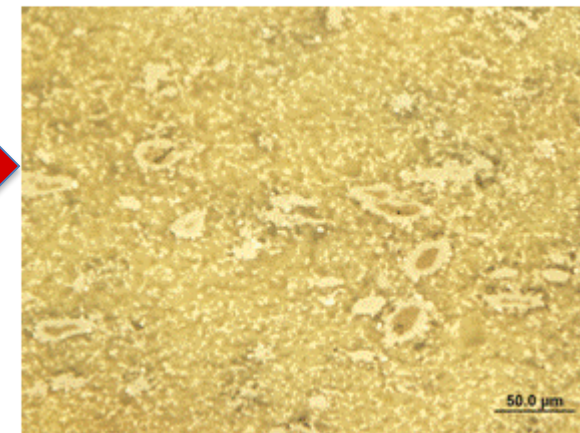



Binder Jet Additive Manufacturing of SiC



ExOne Innovent

An inkjet printing head moves across a bed of powder and deposits a liquid binding material.



Powder Blending

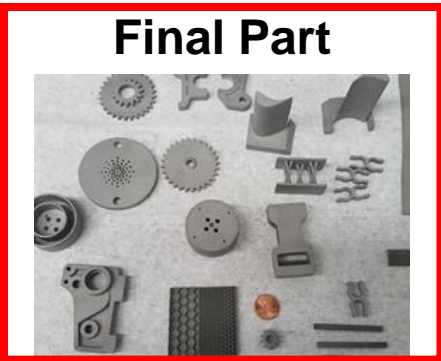
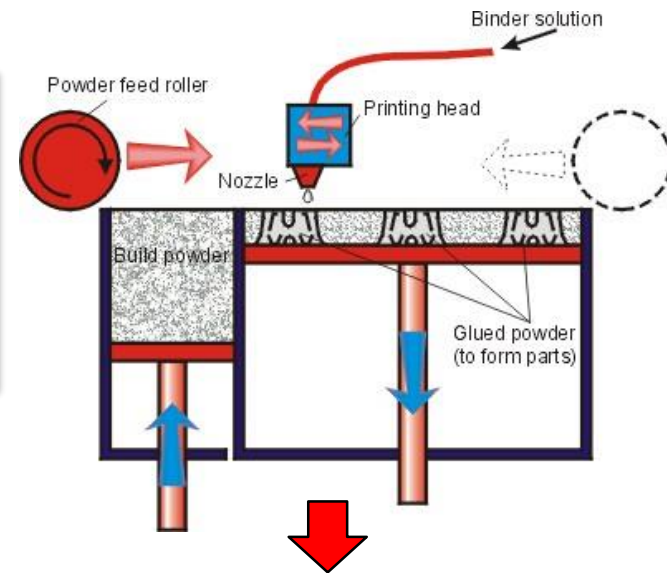
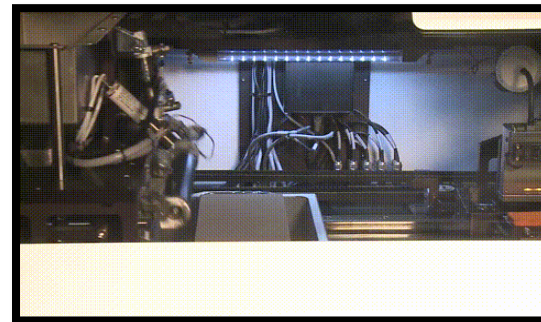

Final Part



Infiltration



Green part

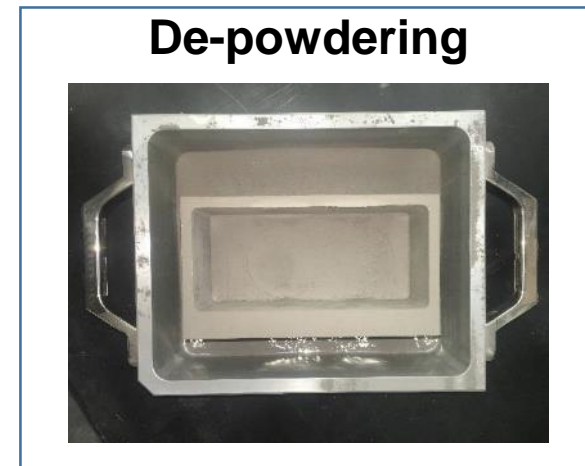

De-powdering

Binder jet printing capability allows for powder bed processing with tailored binders and chopped fiber reinforcements for advanced ceramics.

Binder Jetting of SiC Fiber / SiC Matrix Composites

ExOne Innovent



Constituents

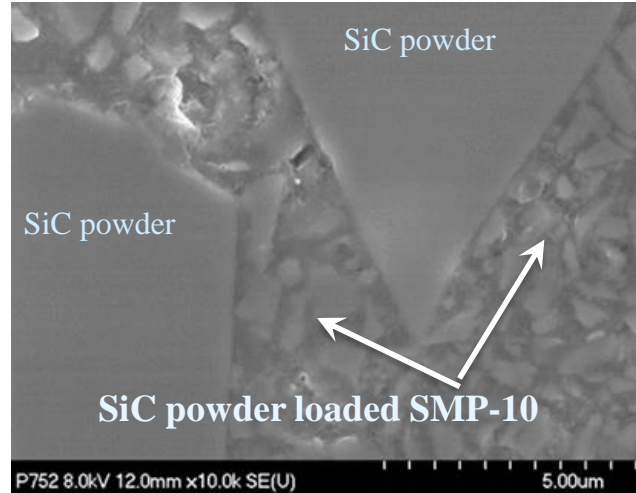

~70 μm long and
~7 μm in diameter

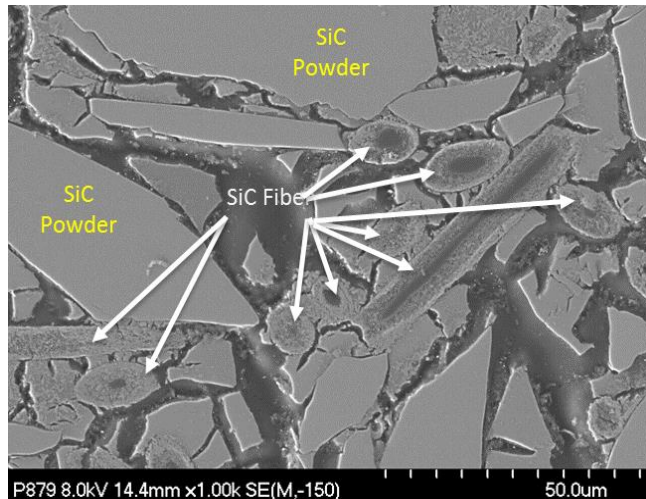

Fiber Reinforced Ceramic Matrix Composite



High pressure turbine cooled doublet vane sections.





Approach for Additive Manufacturing of CMCs

Processing

- Constituents

- SiC powders: Carborex 220, 240, 360, and 600 powders (median grain sizes of 53, 45, 23, and 9 microns respectively). Used solely and in powder blends
- Infiltrants: SMP-10 (polycarbosilane), SiC powder loaded SMP-10, phenolic (C, Si, SiC powder loaded), pure silicon
- Fiber reinforcement: Si-TUFF SiC fiber; 7 micron mean diameter x 65-70 micron mean length

Microstructure

- Optical microscopy
- Scanning electron microscopy

Properties

- Material density (as-manufactured and after infiltration steps)
- Mechanical properties: 4-point bend tests

Processing, microstructure, and property correlations provide an iterative process for improving the CMC materials.

Constituents

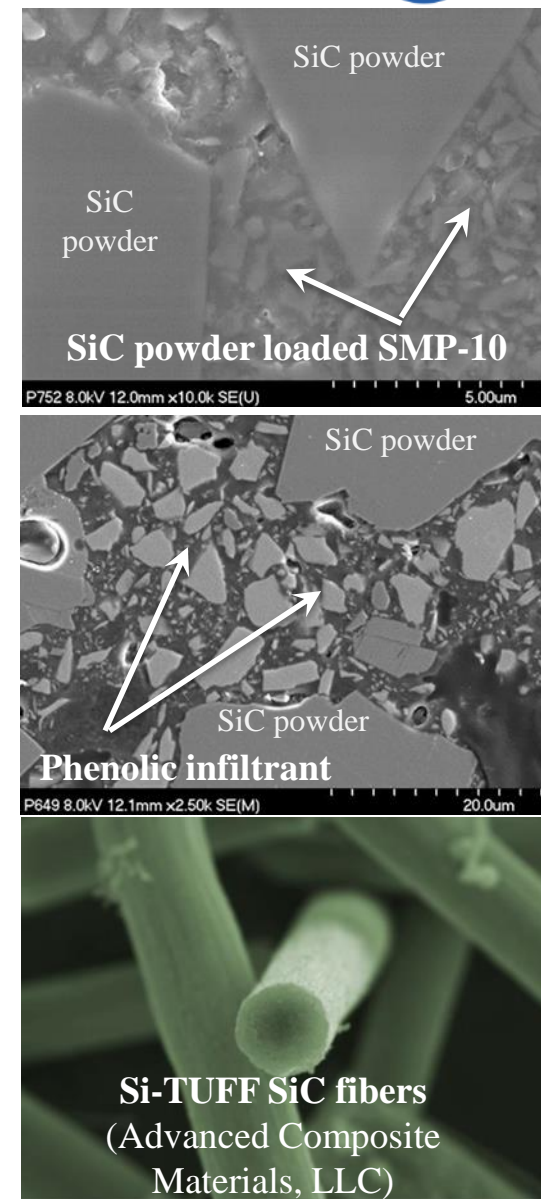

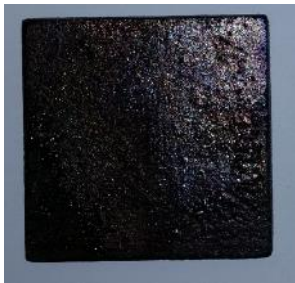

2"x2" CMC coupons

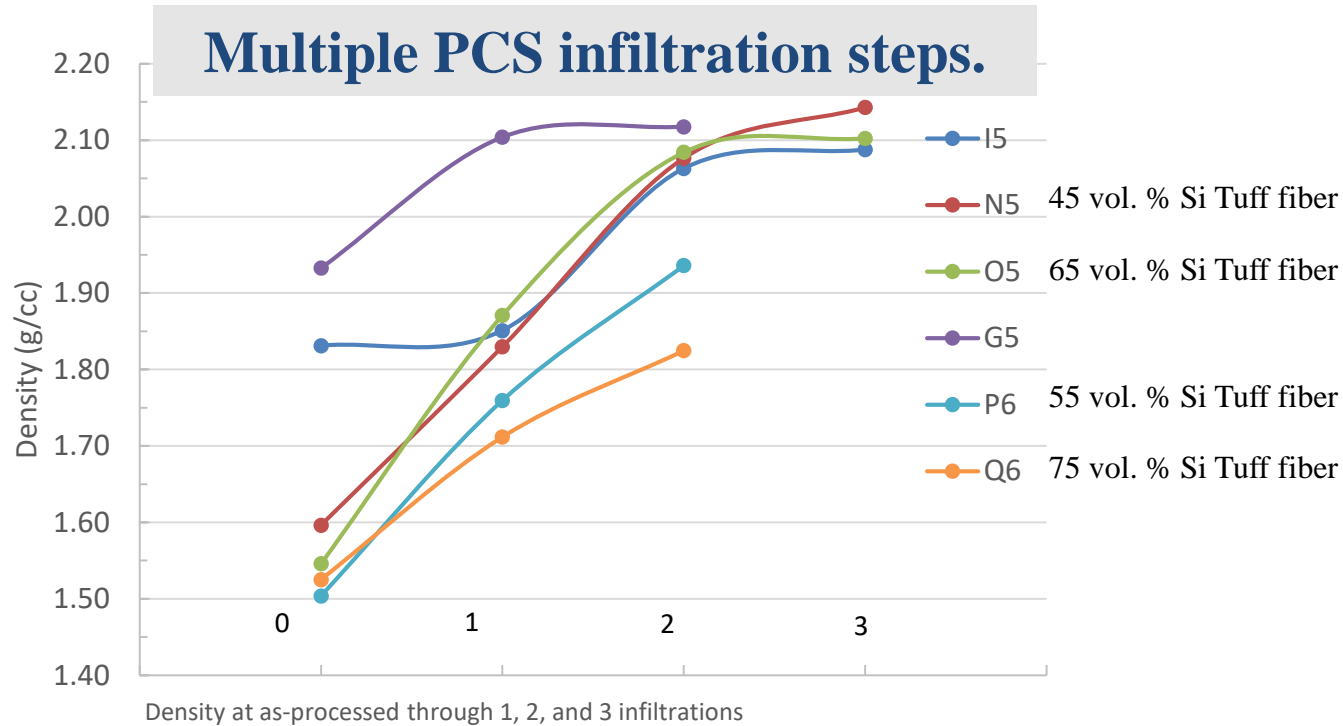

Demonstration of full densification through silicon melt-infiltration.

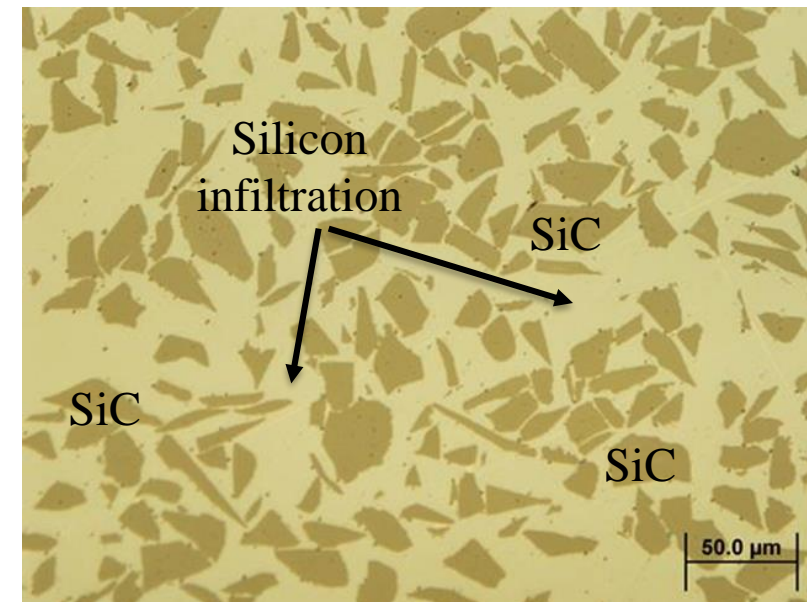

Densities increased by up to 33% from additional PCS infiltration steps and were maintained even at higher SiC fiber loadings of 45, 55, and 65 vol.%.

Polymer approach has a limitation on achievable densities.

Melt infiltration methods such, e.g. silicon melt, can achieve near full density.

Binder Jetting: Cross-Section and Fracture Surface from SiC/SiC Sample with 65 vol.% SiC Fiber

Carborex Powder mix with 65 vol.% Si-Tough SiC fiber, SMP-10 w/800 nano SiC particles vacuum infiltration.

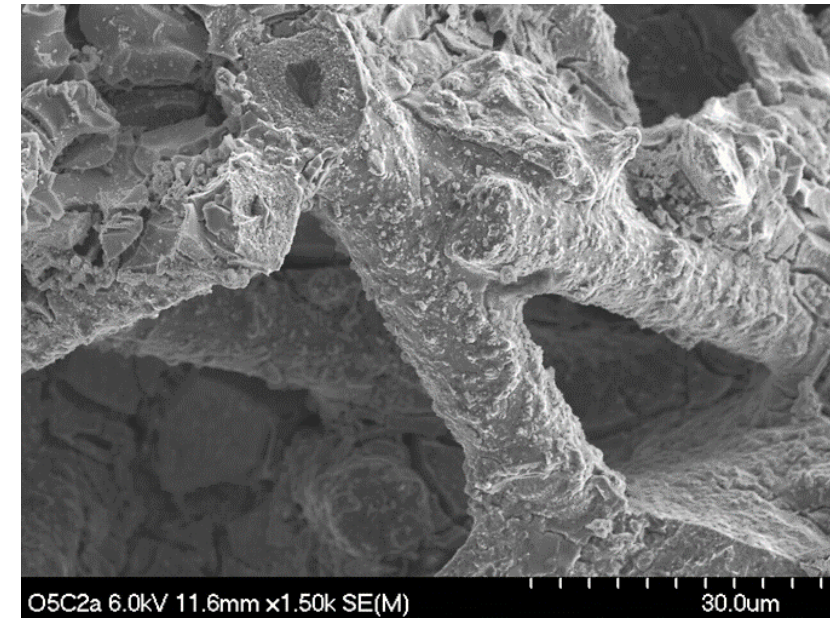
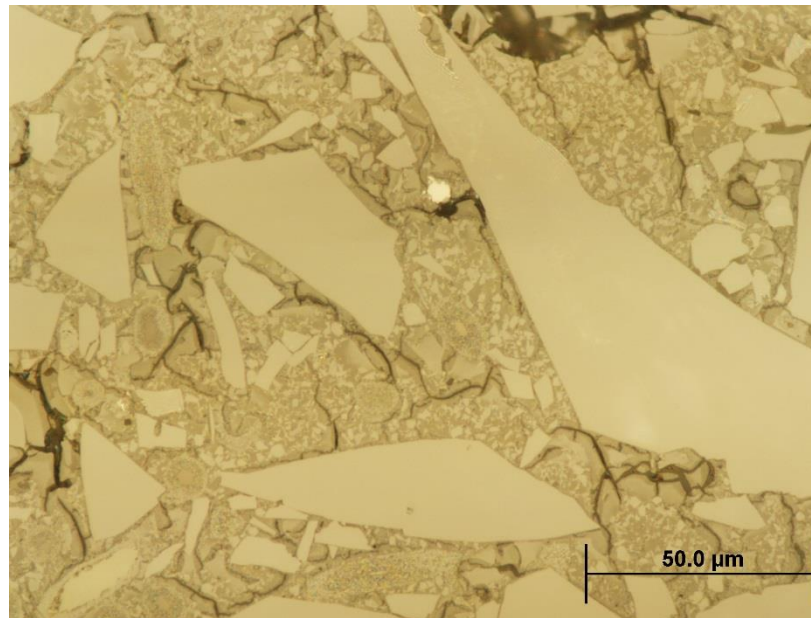
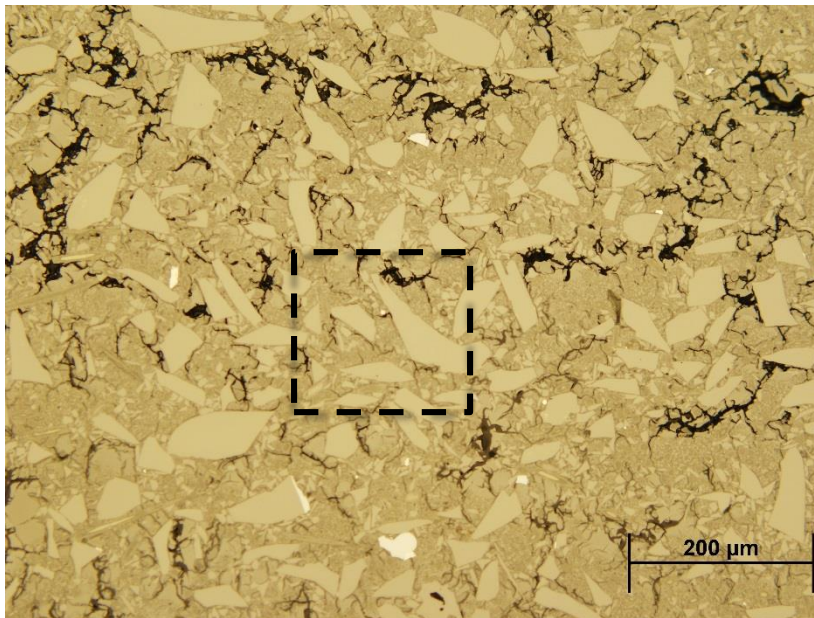

Good densities achieved with high fiber loading.

Binder Jetting: 4 Point Flexure Tests of the Monolithic SiC and CMC materials - at R.T.



Bend bars for strength testing

Non-Reinforced SiC - Set G

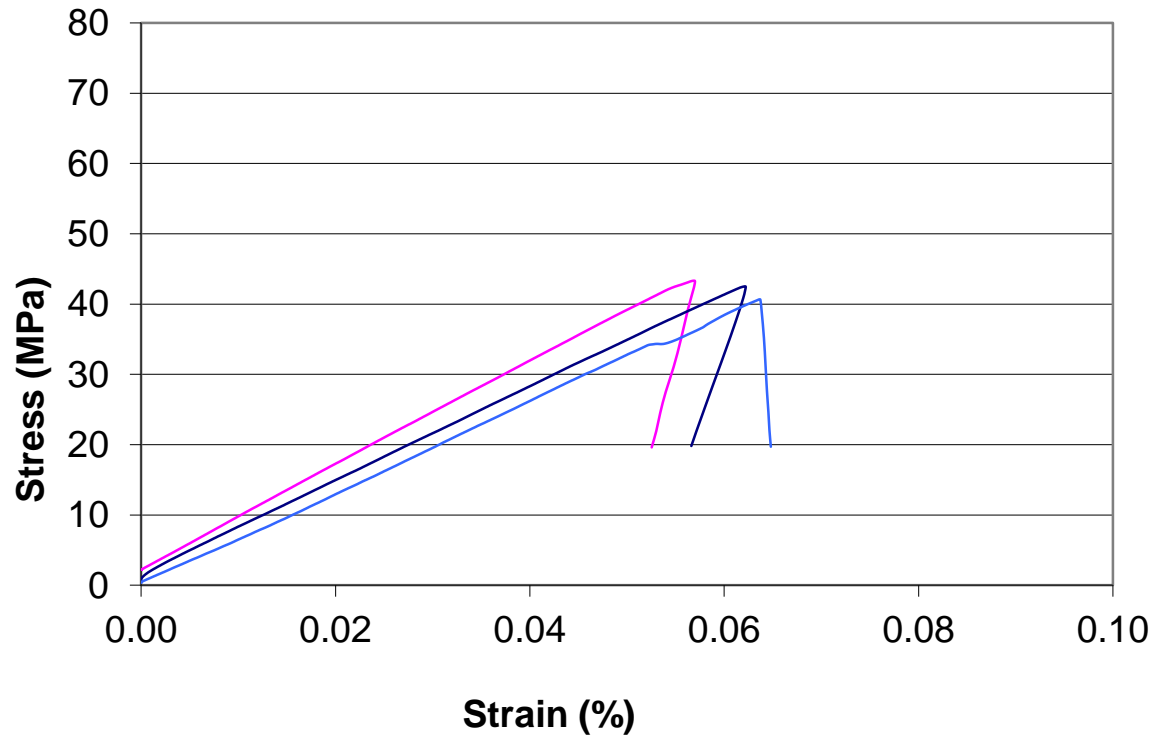

65 vol. % SiC Fiber Reinforced SiC - Set N

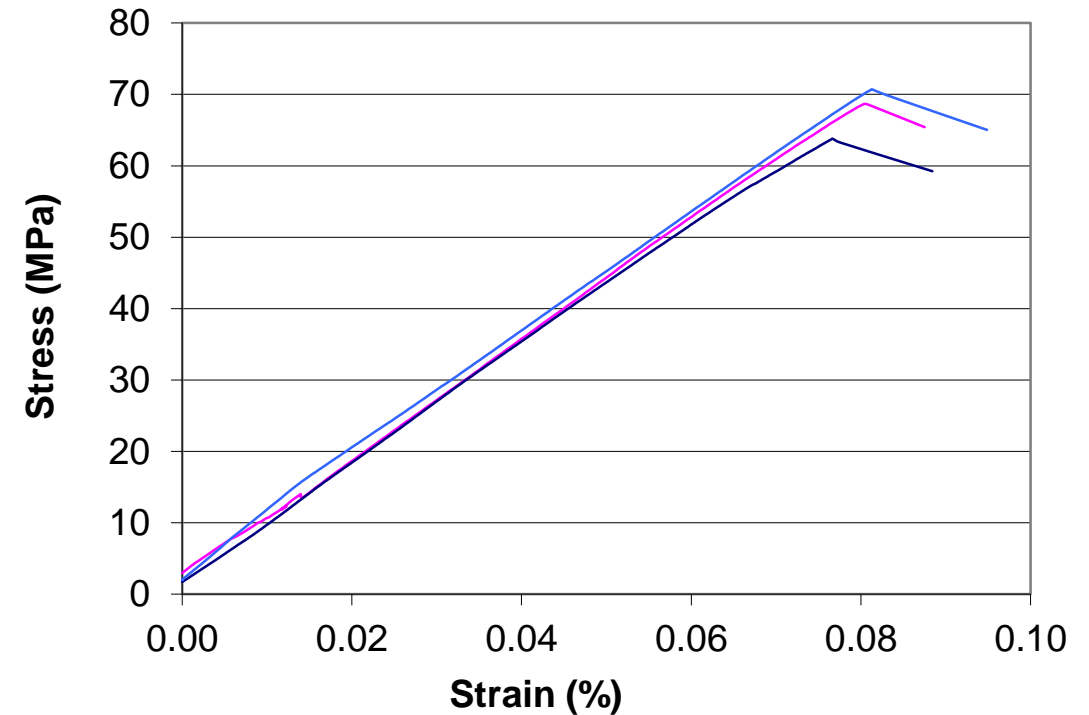

The fiber loaded SiC materials had significantly higher stresses and higher strains to failure.

- Processing and Mechanical Strength Improvements



Four Point Bend Strength

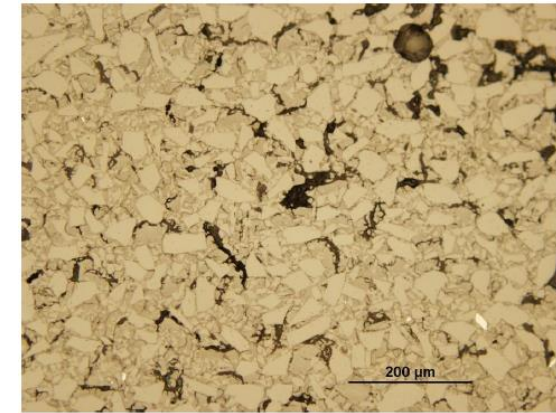
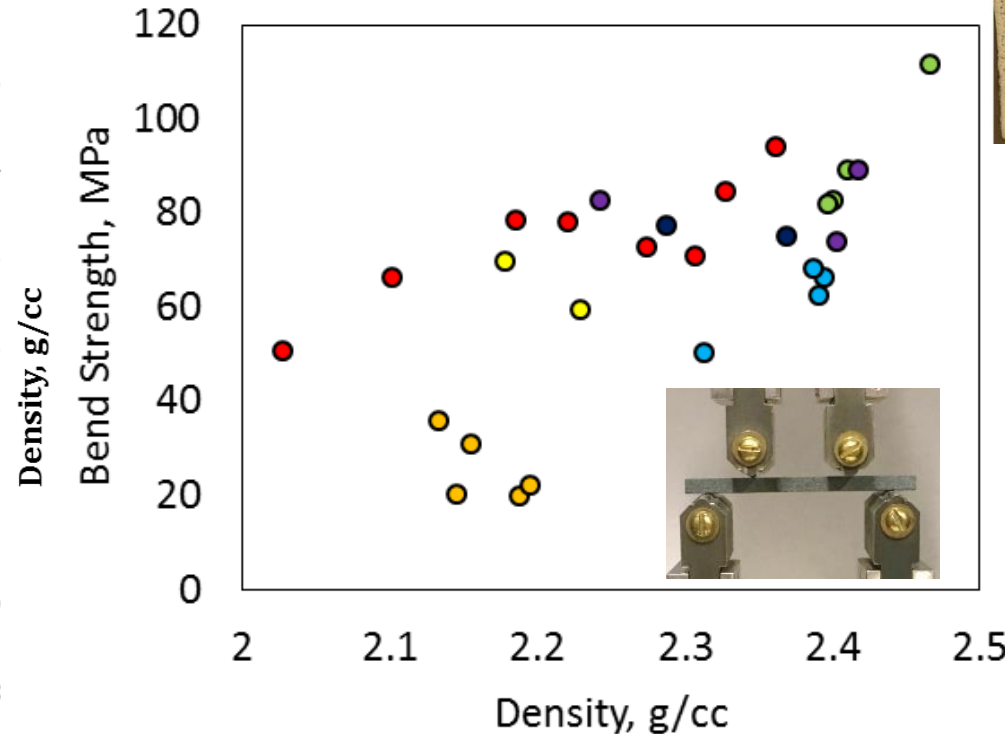
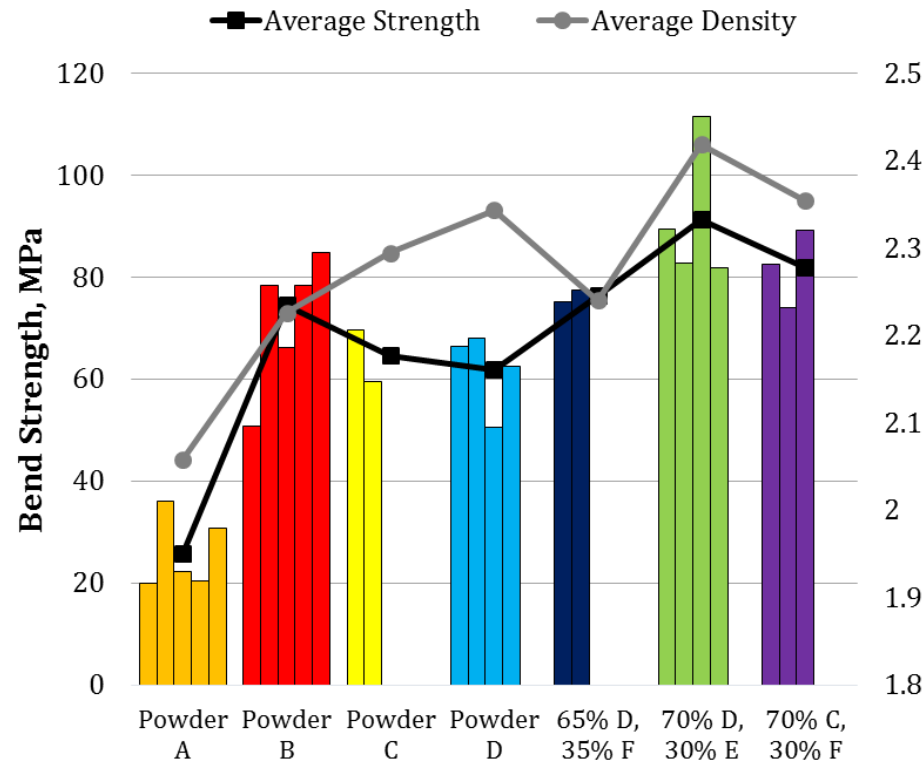

Optical Microscopy of AM SiC after 4 PIP Cycles

- Four point bend tests were conducted on samples after 4 SMP-10 infiltrations
- 50 mm long samples were loaded with a 20 mm loading span and 40 mm support span
- The maximum strength was 111 MPa
- For comparison: Dense CVD SiC and sintered alpha SiC bend strength ranges from 200-450 MPa
- Samples that were tested after 6 infiltrations showed no difference in strength

POC:
Craig Smith
NASA GRC

Demonstration of Polymer Components from FDM

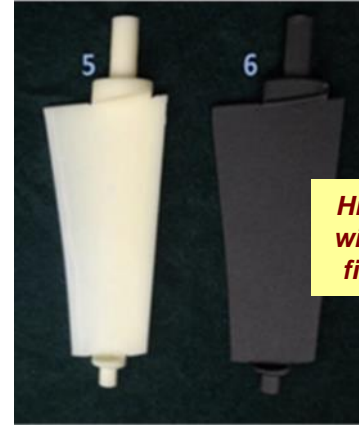
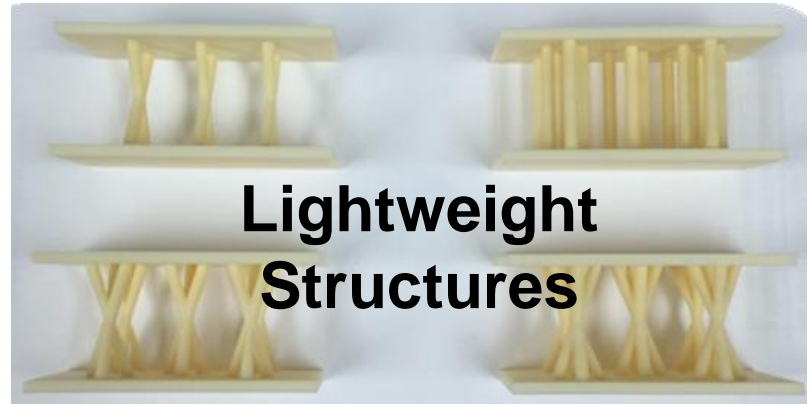
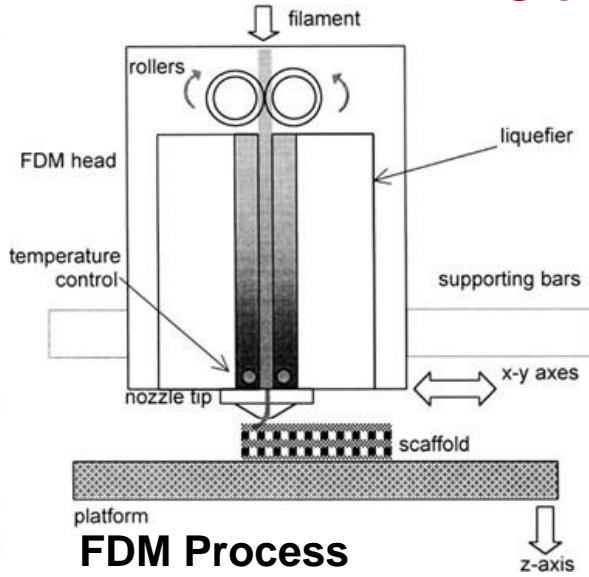

High temp. polymers with chopped carbon fiber reinforcement.

Inlet Guide Vanes from ABS and Ultem 1000



Engine Panel Access Door

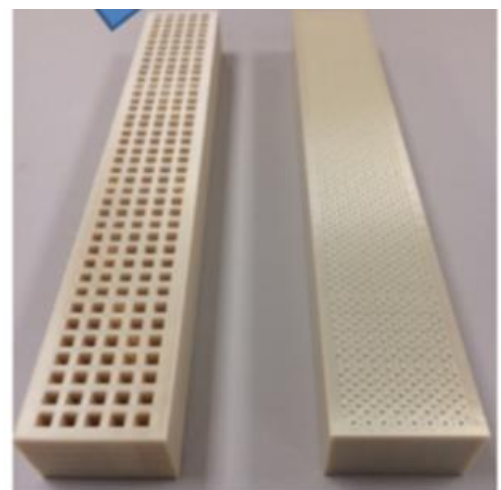

Acoustic Liner Test Articles

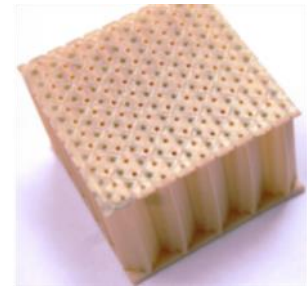

Standard Liner



Complex Geometry

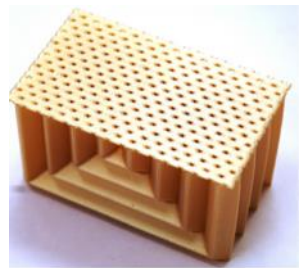

Advanced Liner Design

The focus is on unique structures, high temperature capability, and fiber reinforcement.



FDM of Composite Filaments for Multi-Functional Applications

Potential Missions/Benefits:

- On demand fabrication of as needed functional components in space
- Tailored, high strength, lightweight support structures reinforced with CNT
- Tailored facesheets for functional properties, i.e. *wear resistance, vibration dampening, radiation shielding, acoustic attenuation, thermal management*

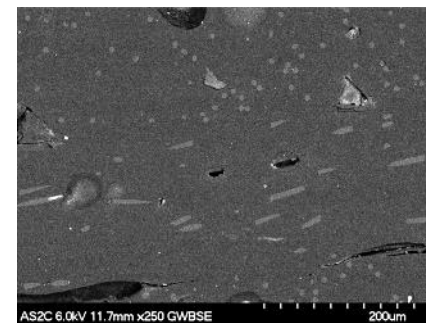
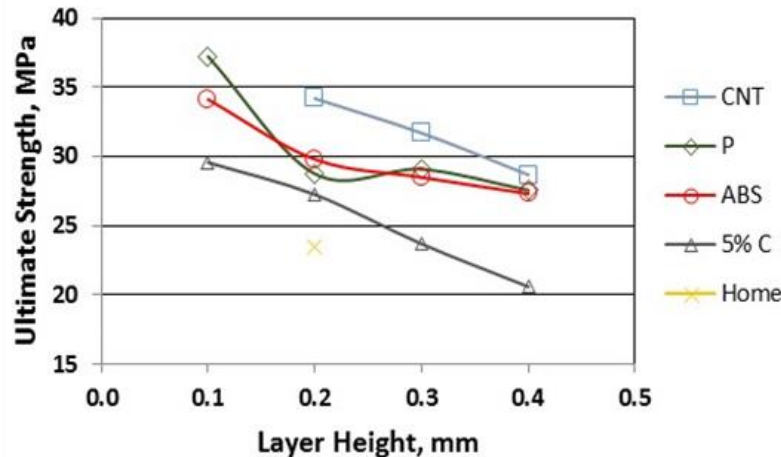
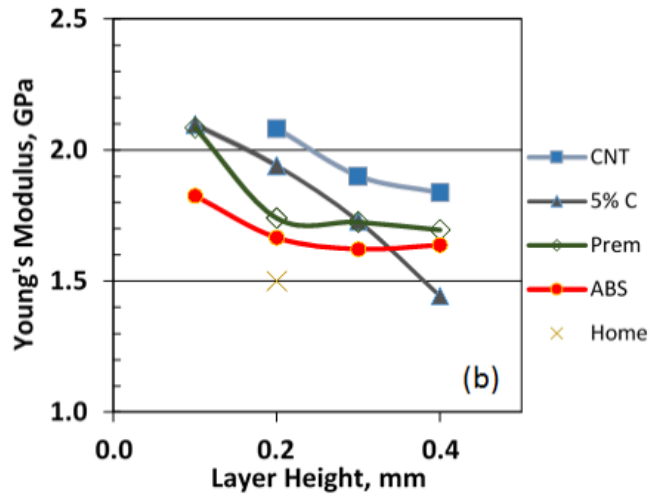
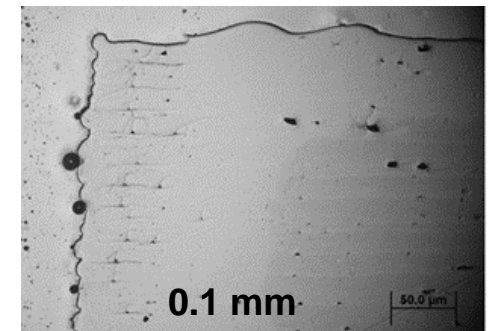
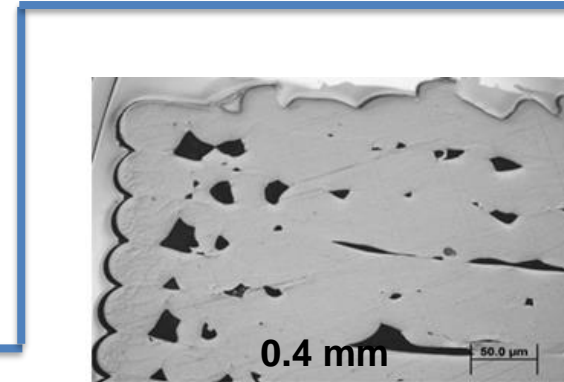
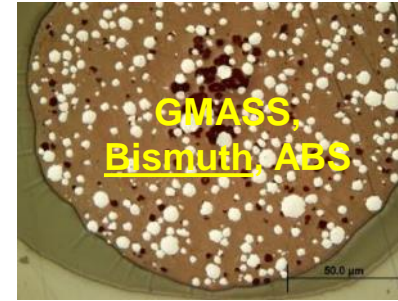
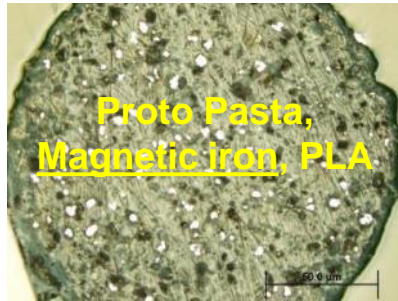
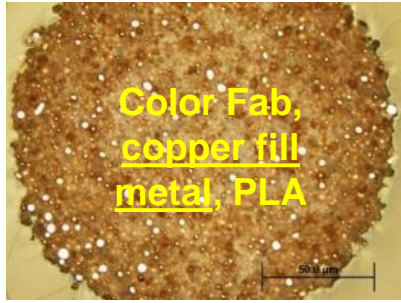

C-Fiber Reinforced ABS Filaments

Effect of print layer height

Filaments used: ABS-standard abs, P-premium abs, CNT-w/carbon nanotubes, C-w/chopped carbon, Home-lab extruded filament

Highest strength and modulus in CNT reinforced coupons versus standard ABS Coupons. Less porosity for lower print heights.



Aircraft Utilizing Electric Motors

Urban Air Mobility

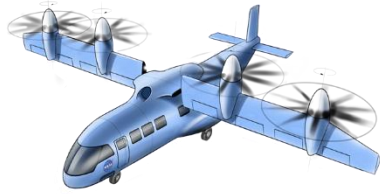

NASA 15-PAX tiltwing aircraft



Uber Elevate

Large Single Isle Transports

STARC-ABL



Hybrid Electric

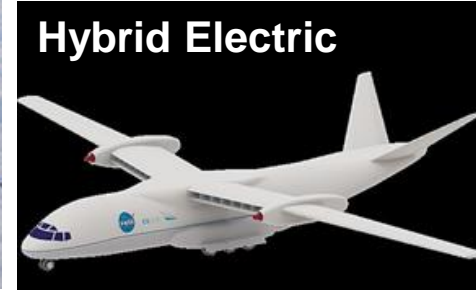

Greased Lightning GL-10



X-57: Distributed Propulsion



CAMIEM: Compact Additively Manufactured Innovative Electric Motors

Objective: Utilize additive manufacturing (AM) methods to achieve new motor designs that have significantly higher power densities and/or efficiency.

Mission: efficient, low emission aircraft for Urban Air Mobility.

Methods:

- New topologies with compact designs, lightweight structures, innovative cooling, high copper fill, and multi-material systems/components.
- New component designs for the rotors, housing, finned stator cooling ring, direct printed stator, and a wire embed stator.
- Compare new components/new motor against a baseline motor.



CAMIEM Baseline Motor

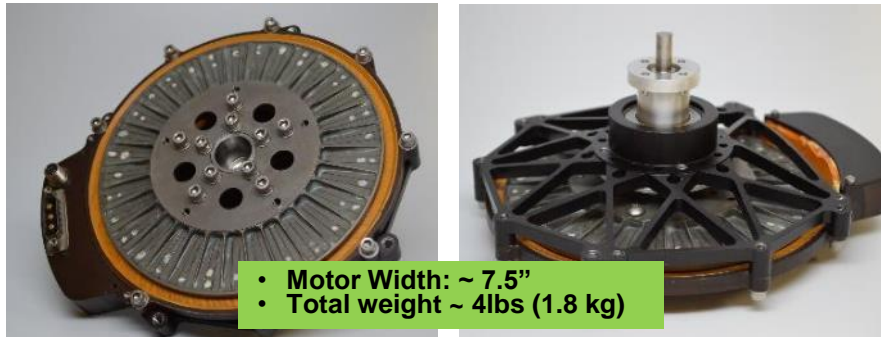

Already SOA due to compact design, high power density, and halbach array of magnets.

CAMIEM AM Motor Design



Projecting a 2x increase in Power Density to 10 kW/kg.

GRC Dynamometer



For development of advanced materials, structures, and components.

Compact Additively Manufactured Innovative Electric Motor (CAMIEM) team members: NASA (GRC, LaRC, ARC), LaunchPoint Technologies and the University of Texas - El Paso



Feasibility Assessment

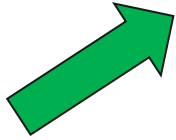
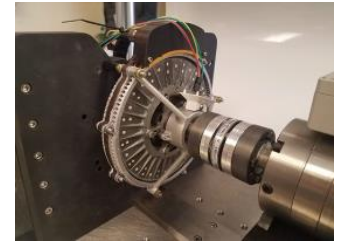
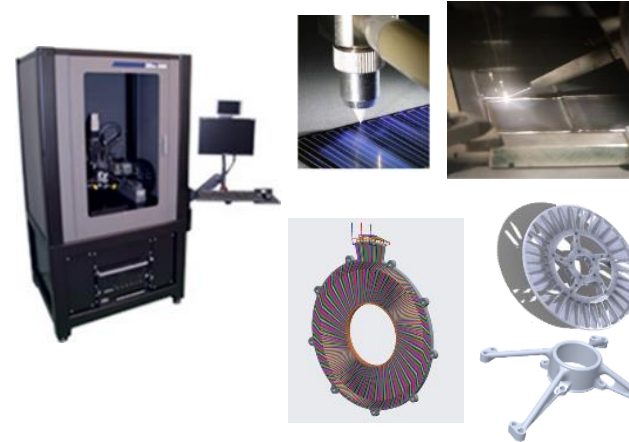

Baseline Motor Testing
for baseline performance

Additive Manufacturing Processes and Advanced Components

Testing of "New" Motor Configurations to Determine Improved Performance



Baseline Motor

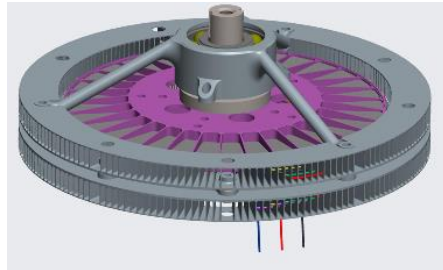

Innovative Motor Design



Aircraft Level System Studies

Feasibility Assessed and Benefits Determined

AM and Hybrid Approaches for Electric Motor Components

Electric Motors

Components of a Commercial Axial Flux Motor



NASA Electric Motor with AM Components

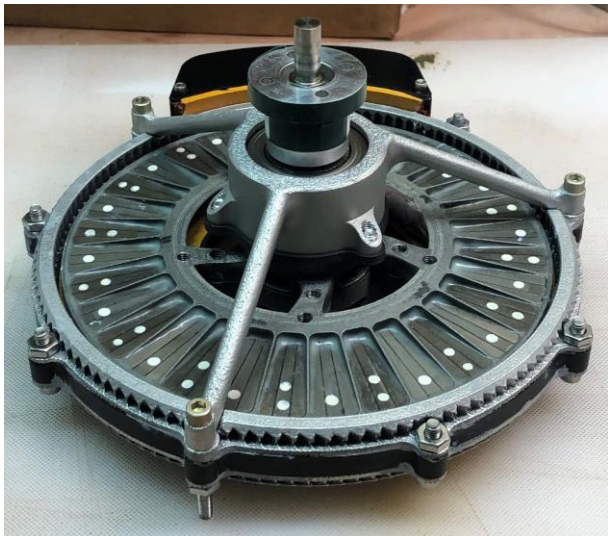

Stators



Litz Wire Coreless Stator

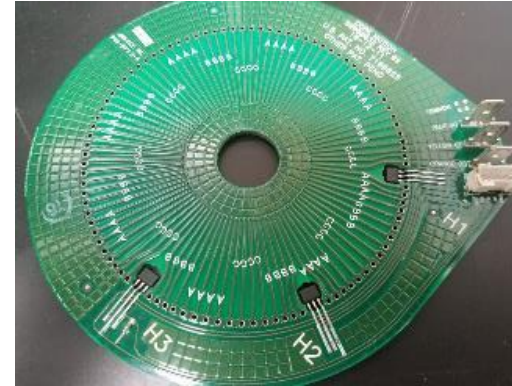

PCB Coreless Stator

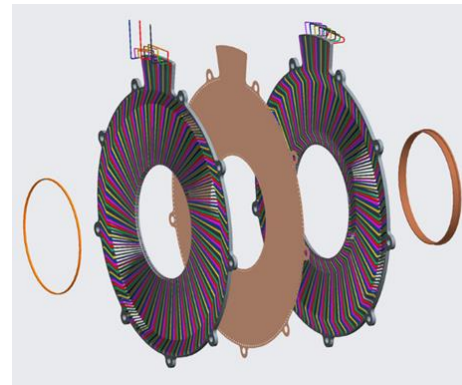

Iron Core Stator with Direct Printed Coils

Stator Constituents:

- Conductor: copper, silver.
- Insulators: coatings, dielectrics, epoxy, high temp. polymer.
- Soft magnets (for cores): iron alloys.

Rotors

Additively Manufactured Rotor Plate



Rotor Constituents:

- Permanent magnets.
- High strength structure (typically metallic).

Direct Printed Stators



Benefits

- Higher magnetic flux, torque, and motor constant (K_m).
- Higher temp. capability of $>220^{\circ}\text{C}$ instead of 160°C for baseline stator.
- Direct printed silver coils with high fill.



Concept A

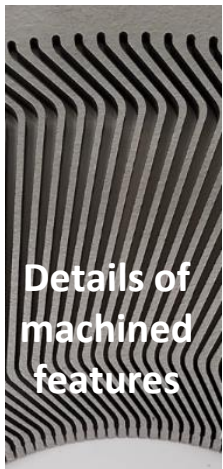
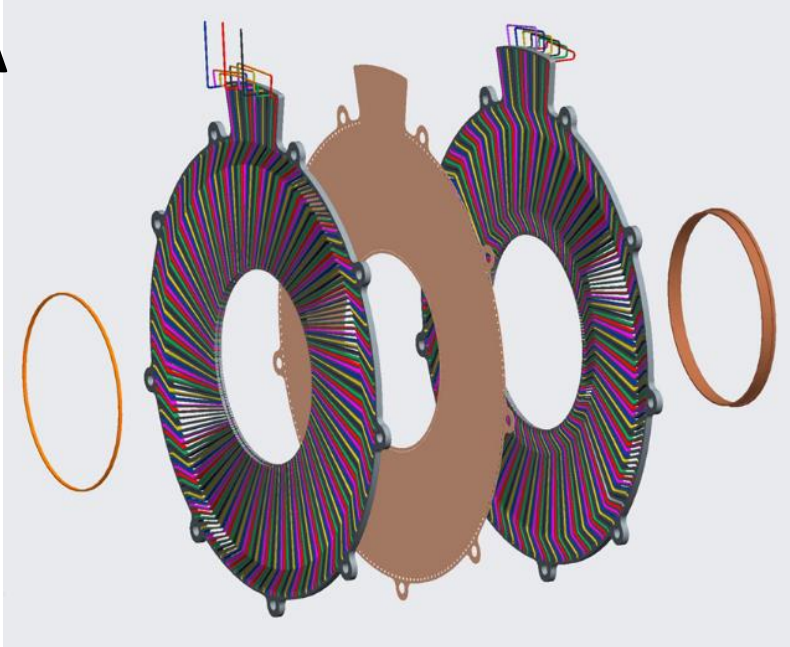
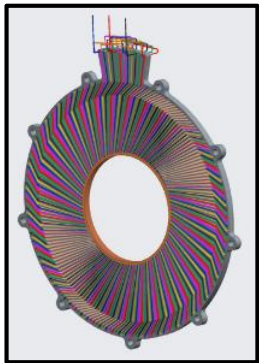

Details of machined features



Stator Plate from Cobalt-Iron Alloy



Cirlex Middle Layer



Outer Rings

nScript 3Dn-300

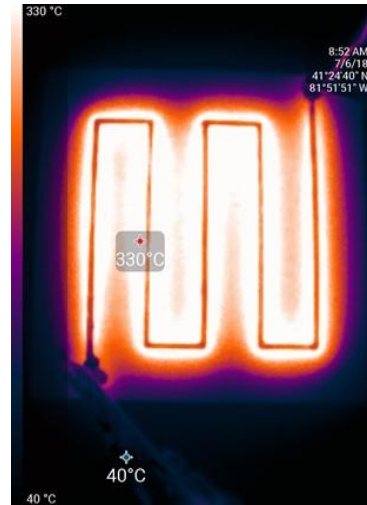
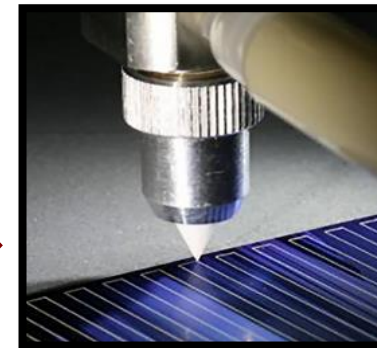

Direct Printed Silver Coils - High Current Test

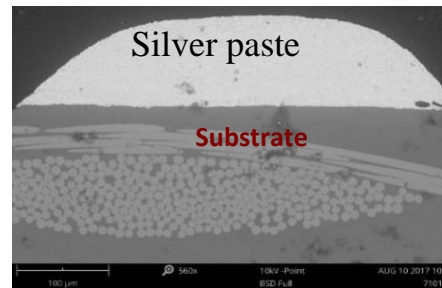

Silver paste

Substrate

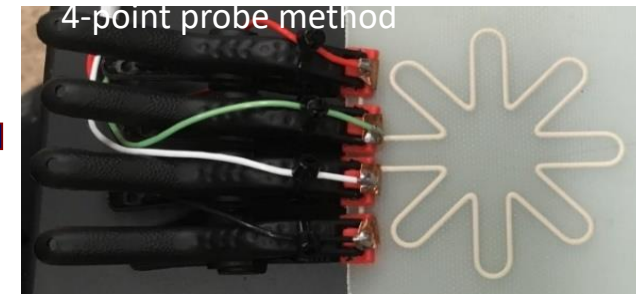

4-point probe method

Additively Manufactured Stator Plates

Soft Magnet

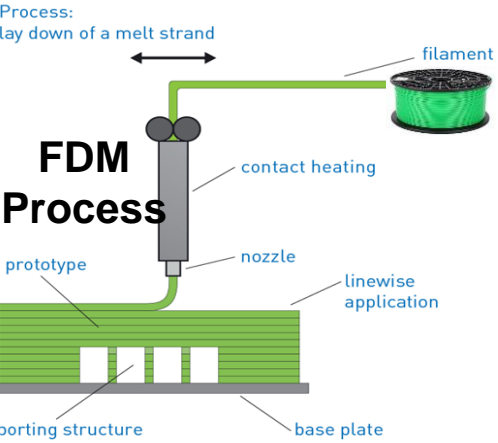

High Temp. Polymer



FDM from Extem (Tg of 311°C) (left) and Ultem 1010 (TG of 217°C) (right) FDM filament.

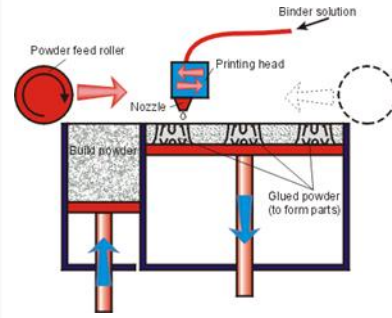

Binder Jetting

Stator Plate from Cobalt-Iron Alloy



Electric magnetic laminated sheets

Laminated sheets which are coated by insulating layer
High Joule heat in plane which is perpendicular to the magnetic field

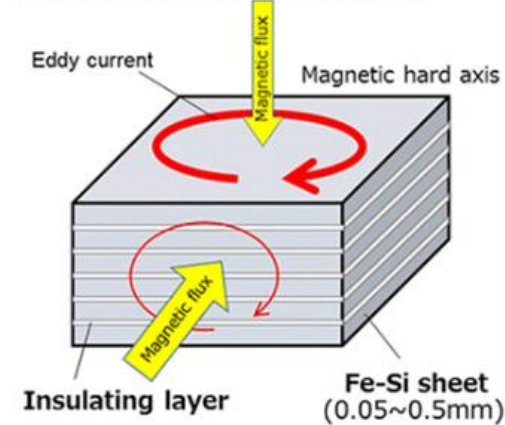

Soft magnetic composite materials

Compacting powders which are covered with insulating film

Low Joule heat along any direction

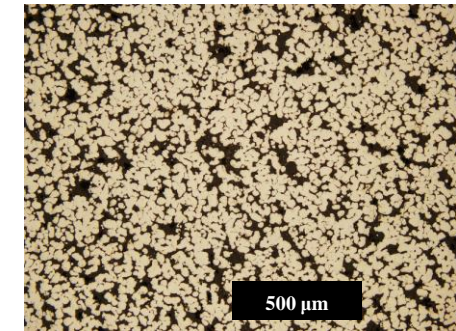
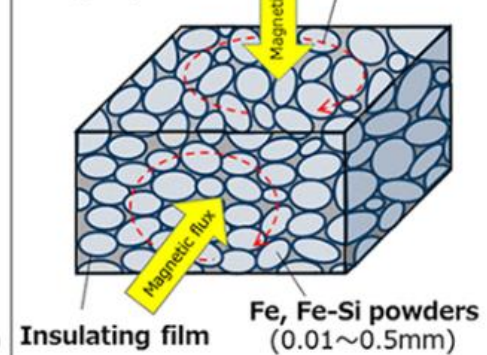

1200°C – 51.3% TD

Low cost and rapidly manufactured sub-components may be possible with further advancements or alternate AM processes.



Comparison of Methods to Obtain Outside Fabrication for Channeled Plates for Stators

Concept A - Stator Plates from Cobalt-Iron Alloy



Concept B - Stator Plates from Cirlex

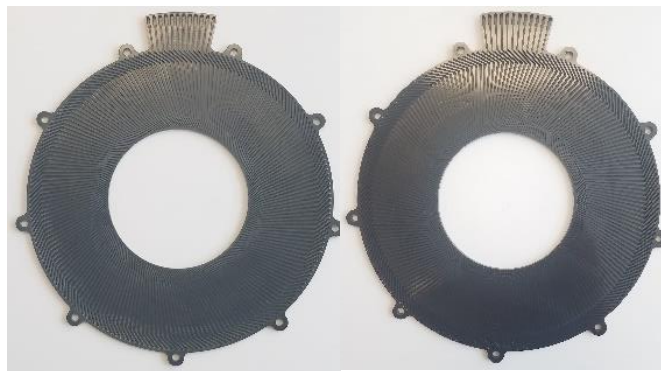

Concept B - Stator Plates from Ultem1010

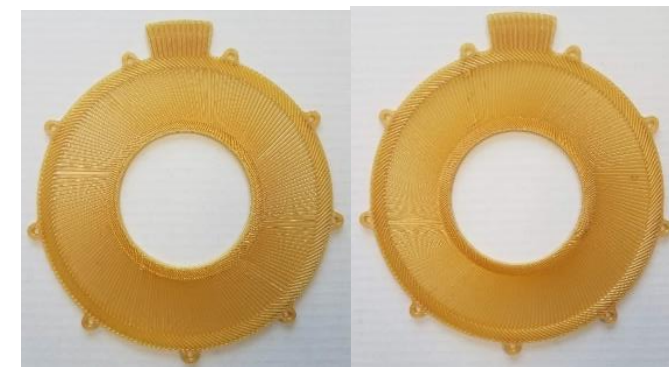

Fabrication Method

Machine/EDM

Machine/Mill

3D Print/FDM

Fabrication Time

4+ months

3 months

1 week (92.3% reduction)

Fabrication Costs

\$21,400

\$19,870

\$1,000

Material Costs

\$600

\$330

\$0 (included in fab.)

Total Costs

\$22,000

\$20,200

\$1,000 (95.0% reduction)

Currently relying on machined stator plates.

Direct Printing for Innovative Stator Designs for Electric Motors

Samples were printed on the nScript 3Dn-300.

Crucial Parameters:

- Print Speed
- Dispensing Pressure
- Nozzle Diameter
- Print Offset
- Valve Opening

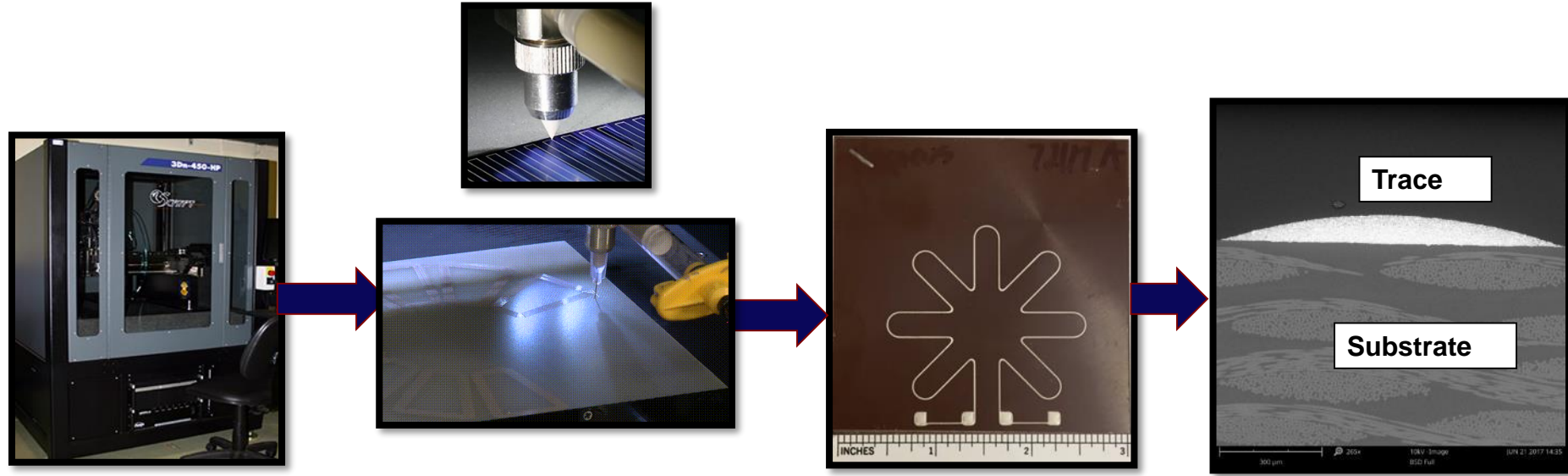

Thin Surface and Imbedded Thick 4-Pt Probe Windings

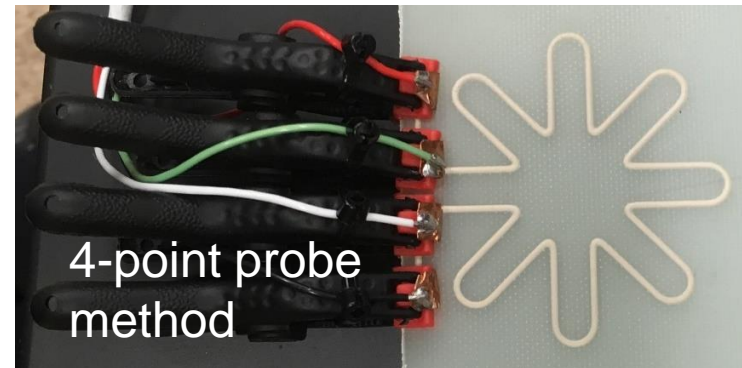
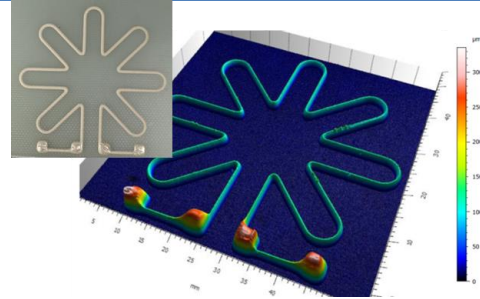

Evaluation of Silver Pastes

PLAIN PASTE

Paste Composition	Lowest Resistivity Obtained [Ωm]	Conductivity [Ωm] ⁻¹	Max Temp (*C)	Vendor Resistivity
CL-11190 (Heraeus)	2.06×10^{-8}	4.86×10^7	300	N/A
CB028 (DuPont)	2.82×10^{-8}	3.54×10^7	175	7 – 10 (m Ω /sq/mil)
CL20-11127 (Heraeus)	3.6×10^{-8}	2.78×10^7	300	N/A
CB100 (DuPont)	5.23×10^{-8}	1.91×10^7	175	>7.5 x 10 ⁻⁸ Ωm
Ag-PM100 (Applied Nanotech)	9.13×10^{-8}	1.10×10^7	300	>5 x 10 ⁻⁸ Ωm
Kapton (DuPont)	2.11×10^{-7}	4.74×10^6	225	<5 (m Ω /sq/mil)

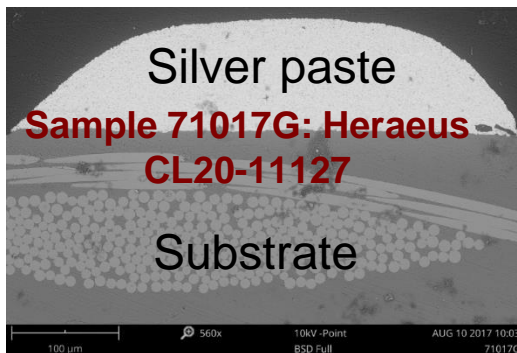

Conductivity of bulk metals [Ωm]⁻¹:

- Silver: 6.3×10^7
- Copper: 6.0×10^7

Printed conductors will have a higher effective conductivity than the Litz wire conductors.

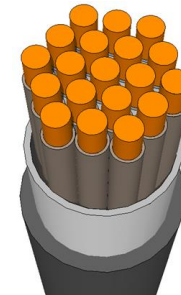

Litz Wire ~60% fill and less in stator windings



Pastes Additions for Higher Electrical Conductivity

Additions of Graphene and Carbon Nanostructures

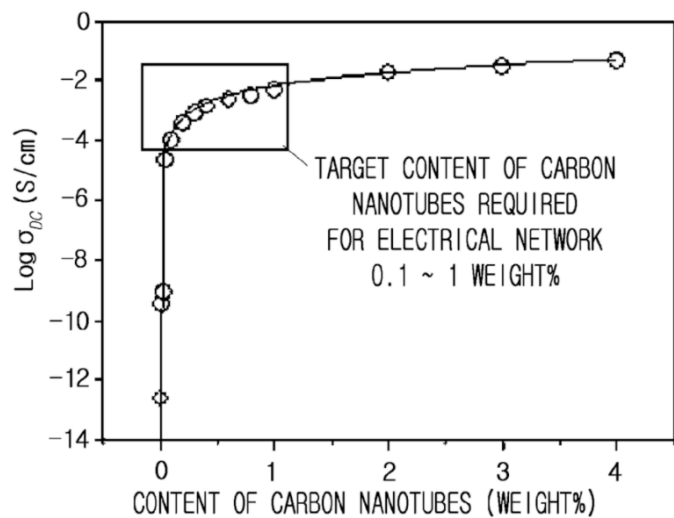
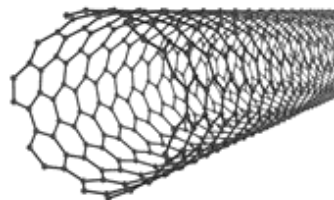
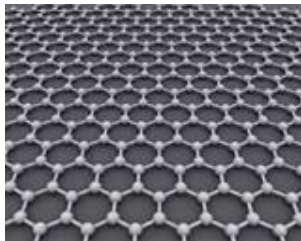

Y. Kim, et al. U.S. Patent 8,481,86, 2013 – Conductive Paste Containing Silver Decorated CNT

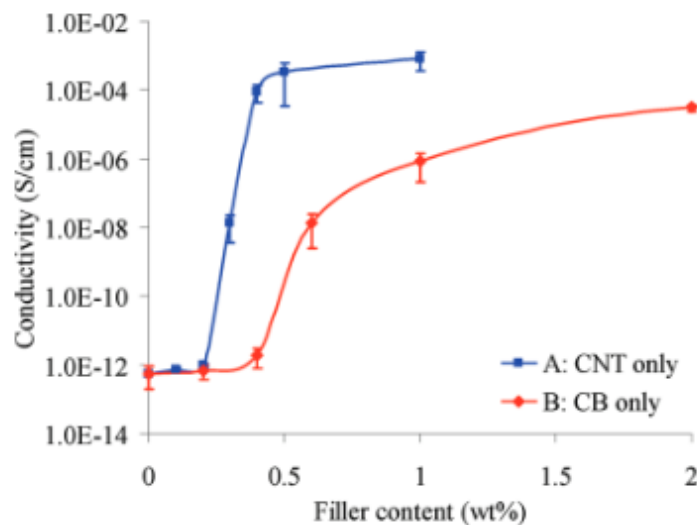

Peng-Cheng Ma, "Enhanced Electrical Conductivity of Nanocomposites Containing Hybrid Fillers of Carbon Nanotubes and Carbon Black."

Plain Pastes		
Paste Composition	Resistivity [Ωm]	Conductivity [Ωm] ⁻¹
Plain CB028	2.82 E-08	3.54 E+07
Plain Heraeus	4.124E-08	2.42E+07
Most Conductive Composites		
Paste Composition	Resistivity [Ωm]	Conductivity [Ωm] ⁻¹
CB028 + 0.2 wt% QUATTRO Graphene	8.148E-08	1.23E+07
Heraeus + 0.04 wt% CNS	8.297E-08	1.21E+07
CB028 + 0.1 wt% QUATTRO Graphene	1.036E-07	9.65E+06
CB028 + 0.085 wt% CNS	1.114E-07	8.97E+06
Heraeus + 0.14 wt% CNS	1.191E-07	8.40E+06
CB028 + 0.2 wt% MONO Graphene	1.261E-07	7.93E+06
CB028 + 0.5 wt% MONO Graphene	1.419E-07	7.05E+06

Advanced Sintering Processes for Higher Electrical Conductivity



Photonic Sintering

Higher Electrical Conductivity

Investigating the use for photonic sintering for printed silver inks.

- Rapid post processing of conductive patterns
- Few second to minute processing times without damaging/heating the substrate

Photonic Sintering for high through-put

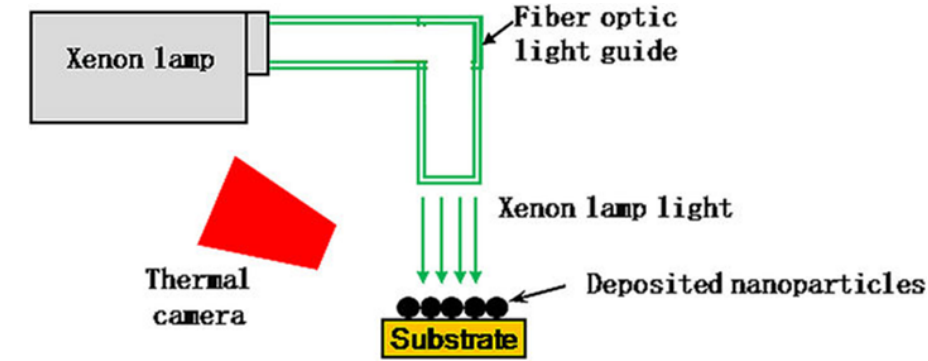

Heraeus CL20-11127 Thermally Cured on Fiberglass (195°C/1hr due to substrate limitations)

Sample Name	Resistance [Ωm]	Conductivity [Ωm] ⁻¹
71017G	4.37×10^{-8}	2.29×10^7
71017H	5.75×10^{-8}	1.74×10^7

Heraeus CL20-11127 Thermally Cured on Vespel (300°C/1hr)

72117A	4.12×10^{-8}	2.42×10^7
--------	-----------------------	--------------------

Heraeus CL20-11127 Photonicallly Cured

71017A	4.89×10^{-8}	2.05×10^7
71017B	4.55×10^{-8}	2.20×10^7
71017C	6.04×10^{-8}	1.65×10^7

DuPont CB028 Thermally Cured on Fiberglass (150°C/1hr)

032917-6	2.82×10^{-8}	3.54×10^7
----------	-----------------------	--------------------

Resistivity greatly improved from 8 ohm in green state to 1.8 ohm after photonic sintering.

Potential, further optimization by investigating offset distance, kV setting, pulses, duration and nano-sized silver particles.

Thermal/Oven Curing



Direct Printed Silver Coils - High Current Test

Temperature capability far exceeds that of the baseline motor which is 180°C.

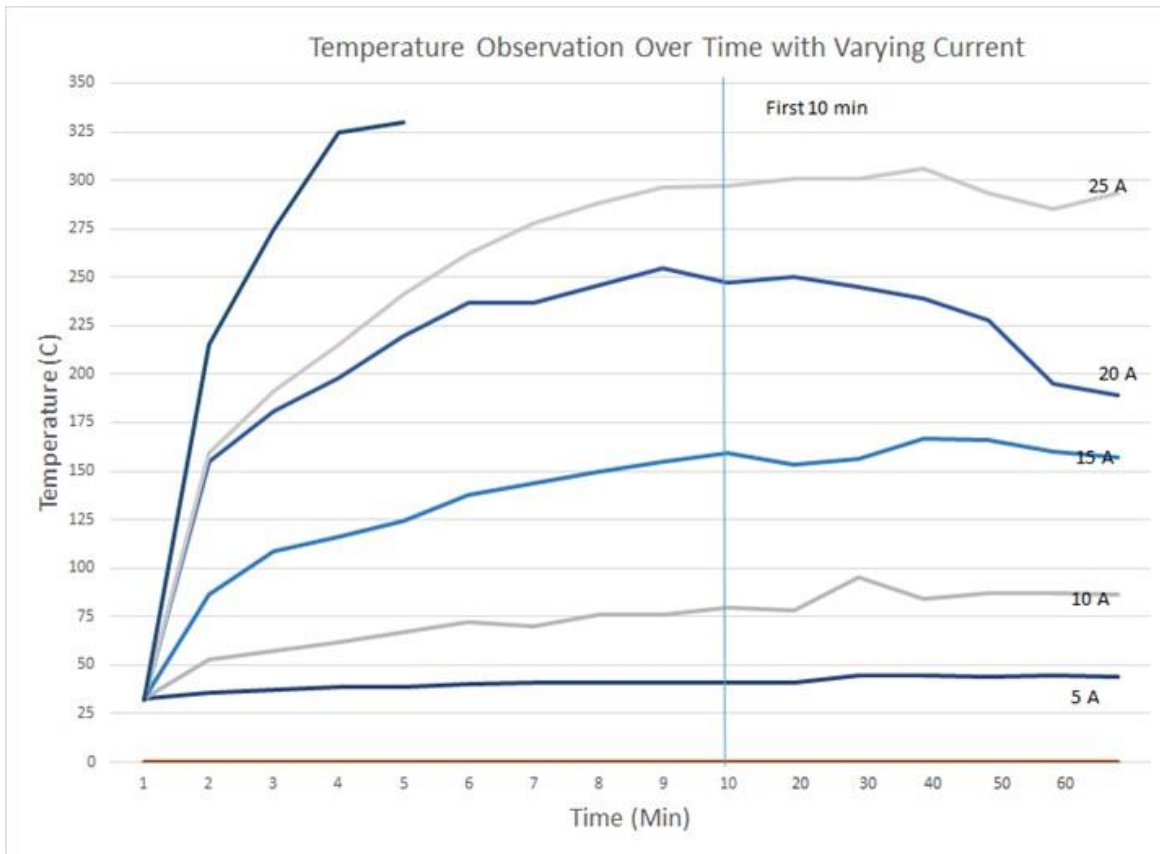
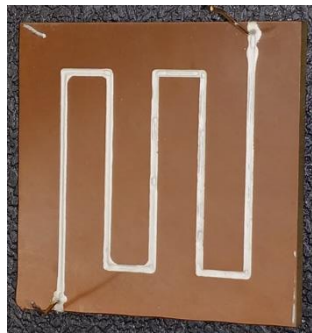
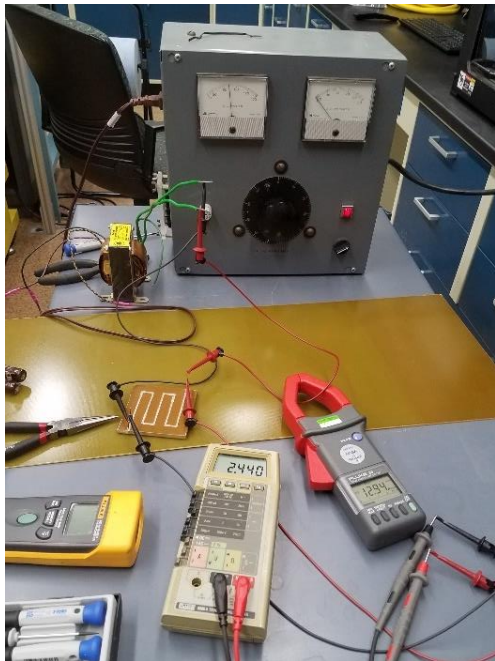

Temperature decreases with extended heat potentially due to self sintering and decreasing resistance within the paste traces.

Testing of Motor Configurations

AFRC prop motor testing:

- Baseline motor
- Motor Version 1: Structural LaRC parts - rotors and housing

GRC motor testing in a dynamometer:

- Baseline motor
- Motor Version 2: Structural LaRC parts - rotors, housing, finned cooling ring



Prop Test Stand



Baseline Motor

Mass = 1968 g

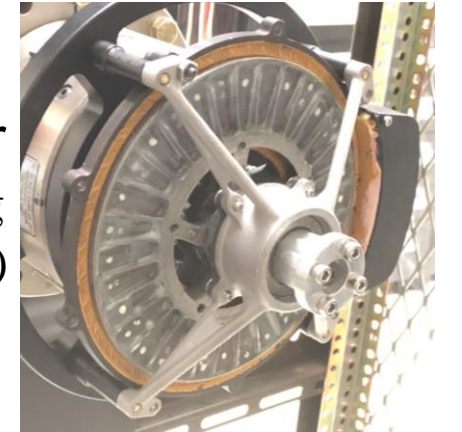

V1. Motor
Mass = 1833 g
(7% less mass)

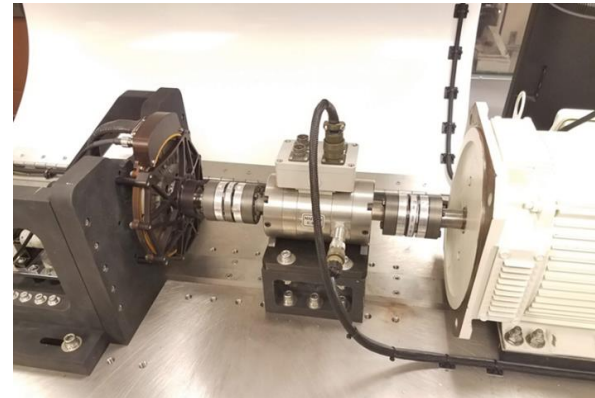
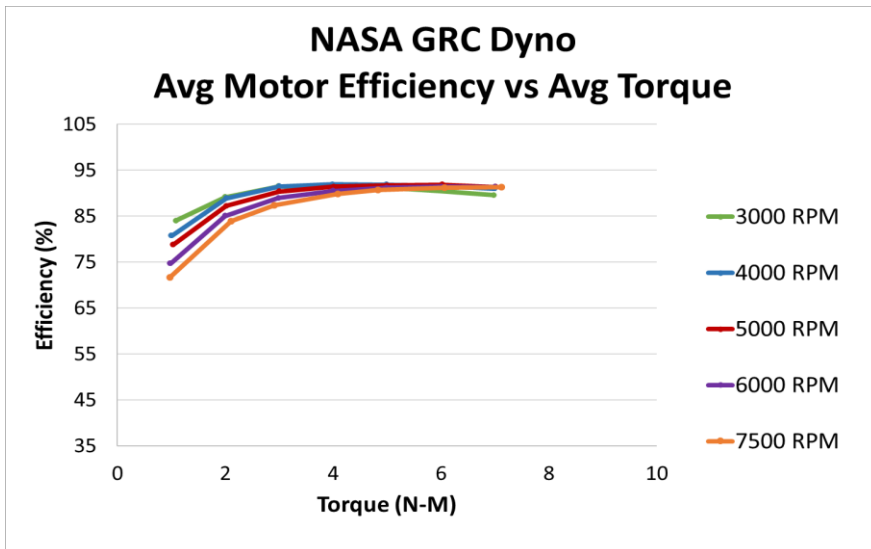

Dynamometer



V2. Motor
Mass = 1870 g
(5% less mass)
Total heat sink mass = 92 g



Summary and Conclusions

Summary

- Good progress is being made in applying additive manufacturing methods to the fabrication of components for turbine engine and electric motors.
- LOM offers continuous fiber reinforced CMCs while the binder jet method offers short fiber reinforced SiC-based ceramics.
- AM offers the potential for electric motors with much higher efficiencies and power densities.
- Additive manufacturing technologies were demonstrated to be capable of enabling new innovative direct printed stator designs for electric motors.
- New electric motor component designs will offer performance gains through such improvements as lighter weights, higher coil packing, higher coil electrically conductive, higher temperature operation, and higher magnetic flux.

The CAMIEM Team and Acknowledgements

Support provided by the Convergent Aeronautics Solutions Project within the ARMD Transformative Aeronautics Concepts Program.



Organization	Name	Role	Organization	Name	Role
Glenn Research Center	Michael Halbig (POC)	PI and GRC POC	Armstrong Flight Research Center	Ethan Niemen (POC)	AFRC POC and ground testing
	Mrityunjay "Jay" Singh	Additive manufacturing		Otto Schnarr III	Electric propulsion ground testing
	Valerie Wiesner			Kirsten Fogg	
	Greg Piper / Daniel Gorican	AM /Direct printing		Patricia Martinez	
	Derek Quade	Dynamometer	Langley Research Center	Samuel Hocker (POC)	Additive manufacturing
	Steven Geng	Motors and magnets		Christopher Stelter	
	Chip Redding	Design		Russell "Buzz" Wincheski	NDE
	Chun-Hua "Kathy" Chuang	Insulator materials		Stephen Hales	Materials evaluation
	Peter Kascak	Electric Motors		John Newman	Computational materials
	Jeff Chin	System benefits	University of Texas El Paso	Jose Coronel (POC)	Stator winding and cooling efficiency
Michael Ricci (POC)	Baseline & innovative motor designs	David Espalin			
Brian Clark		Ryan Wicker			
Dave Paden					

Also Summer Interns at GRC (Anton Salem and Hunter Leonard) and LaRC.