



Solid Fuel Ignition and Extinction (SoFIE) Project on ISS

Paul Ferkul (**Presenter**), USRA

Lauren Brown, NASA Glenn Research Center

Christopher Mroczka, ZIN Technologies, Inc.

Subrata Bhattacharjee, SDSU

Carlos Fernandez-Pello, University of California Berkeley

Fletcher Miller, San Diego State University

Sandra Olson, NASA Glenn Research Center

James T'ien, Case Western Reserve University

Indrek Wichman, Department of Mechanical Engineering, Michigan State University





SoFIE — Solid Fuel Ignition and Extinction



Theme:

Ignition and flammability of solid spacecraft materials in practical geometries and realistic atmospheric conditions

Relevance/Impact:

- Improve EVA spacesuit design
- Safer selection of cabin materials and validate NASA materials flammability selection 1-g test protocols for low-gravity
- Understanding of early fire growth behavior
- Validate material flammability numerical models
- Suppression techniques for burning materials by diluents, flow reduction, and venting

Approach:

- SoFIE facility (CIR insert and avionics) supports multiple solid-material combustion studies
- Utilize Combustion Integrated Rack (CIR)
- Common infrastructure

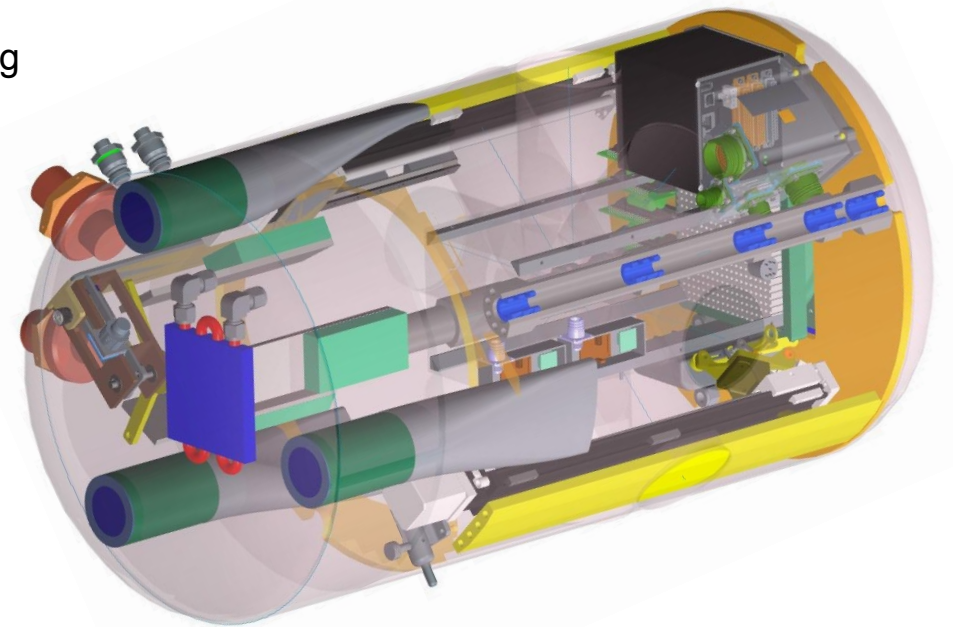

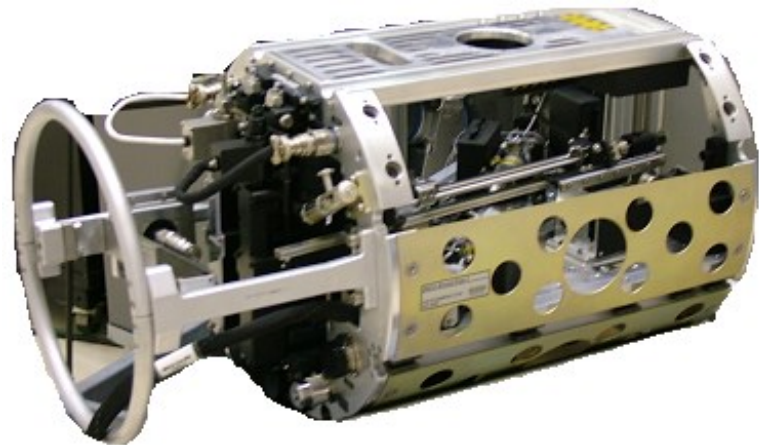

FLEX (Droplet combustion)

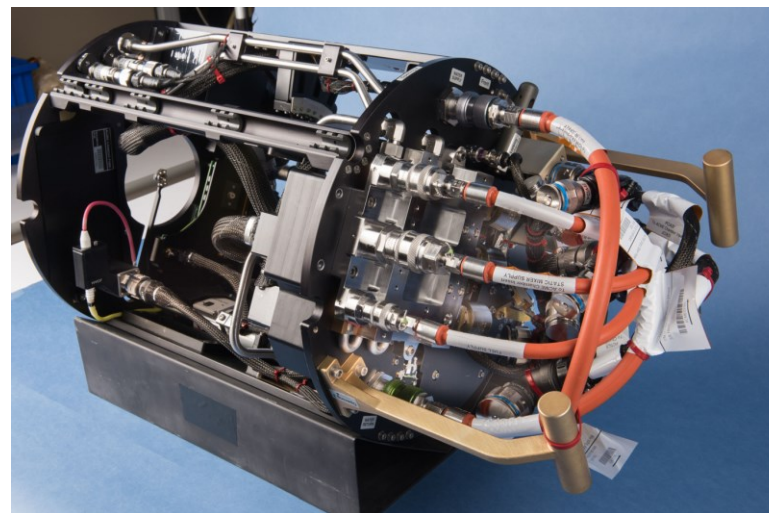

ACME (Advanced Combustion via Microgravity Experiments)

Laminar, gaseous, non-premixed flames.

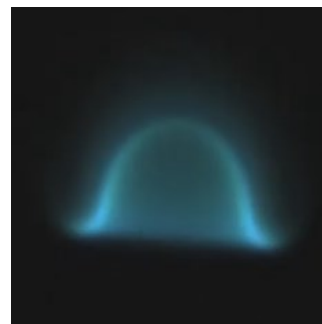
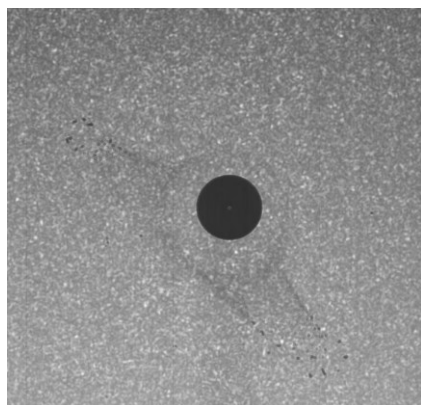



SoFIE — Solid Fuel Ignition and Extinction

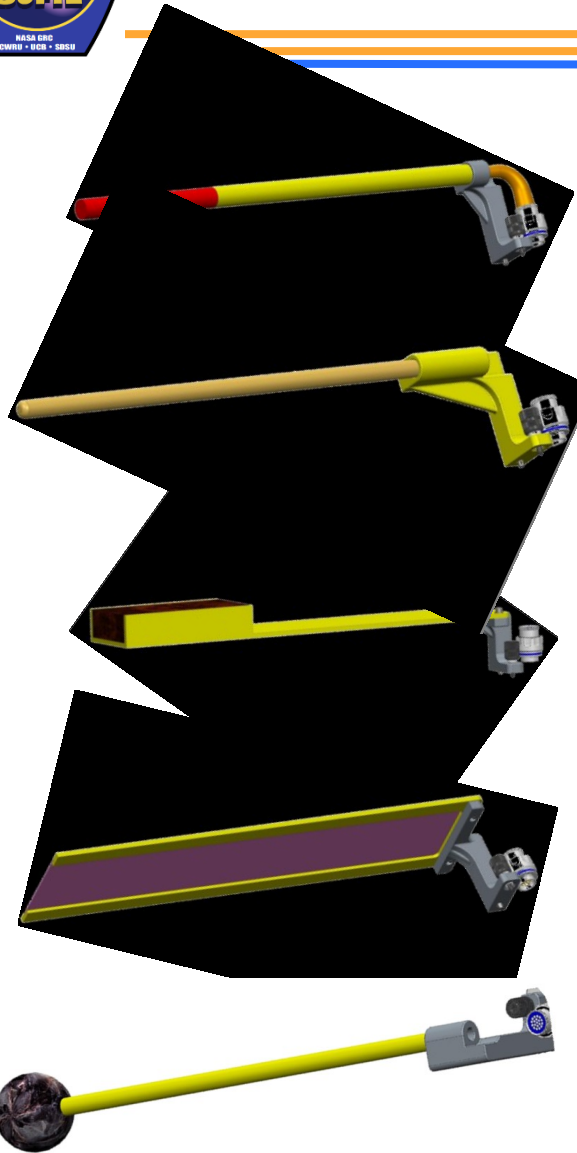

Material Ignition and Suppression Test (MIST); Carlos Fernandez-Pello: UC Berkeley

Fuel: acrylic cylinders (PMMA)

Spacecraft Materials Microgravity Research on Flammability (SM μ RF); Sandra Olson: NASA GRC

Acrylic cylinders (PMMA) and engineering materials (sheets)

Narrow Channel Apparatus (NCA); Fletcher Miller: San Diego State University

Thick acrylic (PMMA)

Residence Time Driven Flame Spread (RTDFS); Subrata Bhattacharjee: San Diego State University

Thin acrylic sheets (PMMA)

Growth and Extinction Limit (GEL); James T'ien: Case Western Reserve University

Acrylic spheres (PMMA)



Material Ignition and Suppression Test (MIST)



PI: Carlos Fernandez-Pello, University of California at Berkeley

Co-I: Michael Gollner, University of California at Berkeley

International Co-I: Nickolay Smirnov, M.V. Lomonosov State University, Moscow, Russia

Objectives:

- Ignition and extinction maps of a solid fuel (PMMA cylinder) as a function of flow, O_2 , and external radiant flux.
- Flammability of materials in space exploration atmospheres.
- Guide interpretation of NASA testing procedures to non-Earth environments.
- Develop ground-based apparatus for application to environments in space-based facilities.
- Theoretical modeling and normal gravity data.

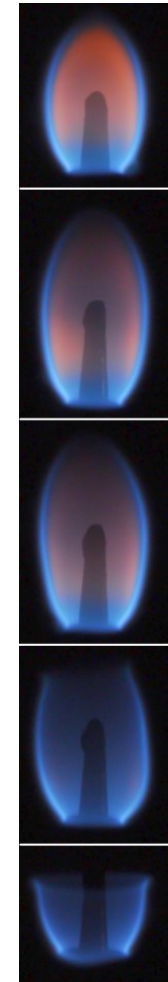



Spacecraft Materials μ g Research on Flammability (SM μ RF)



PI: Sandra Olson, NASA Glenn Research Center

Objectives:

- Flammability map for two materials over the range of interest for spacecraft exploration atmospheres.
- Refine materials fire screening: Tests are g, but materials are more flammable in 0g.
- ★ In the 1-g screening tests, flames extinguish by blowoff.
- ★ In reduced gravity (0g, Lunar g, Martian g), a flame can be sustained at lower O₂.
- ★ **Negative Oxygen Margin of Safety** to de-rate materials. PMMA rods: NOMS = 1.4% O₂
- Thin fuel sheets: few materials rated even in 1g at 34% O₂, 8.2 psia (exploration atmosphere).

Blowoff in **0g**: flame strengthens but then blows off when flow is increased



~15% O₂ ← FLOW



Astronauts Tim Kopra and Scott Kelly are amazed at a BASS-II blowoff test.

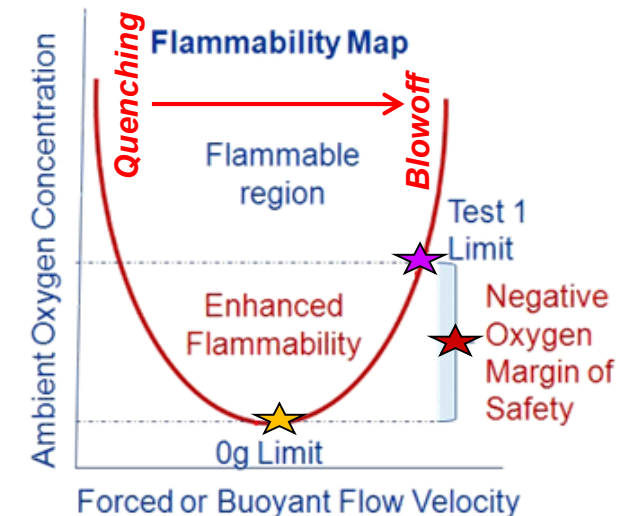

PI: Professor Fletcher Miller, San Diego State University

Co-I: Sandra Olson, NASA GRC and Indrek Wichman, Michigan State University

Objectives:

- 1-g “narrow channel” controls the effect of buoyancy. This will allow microgravity opposed-flow flame spread rate and (possibly) extinction limits to be determined on Earth in the apparatus.
- Flame spread rate across a thick solid fuel (PMMA slabs) as a function of forced opposed flow velocity, oxygen concentration, and pressure (along the normoxic curve).
- Opposed flow extinction limits for thick solid fuel by lowering the velocity until the flame extinguishes at a given oxygen concentration and pressure.
- Compare to a numerical model of the flame spread process.

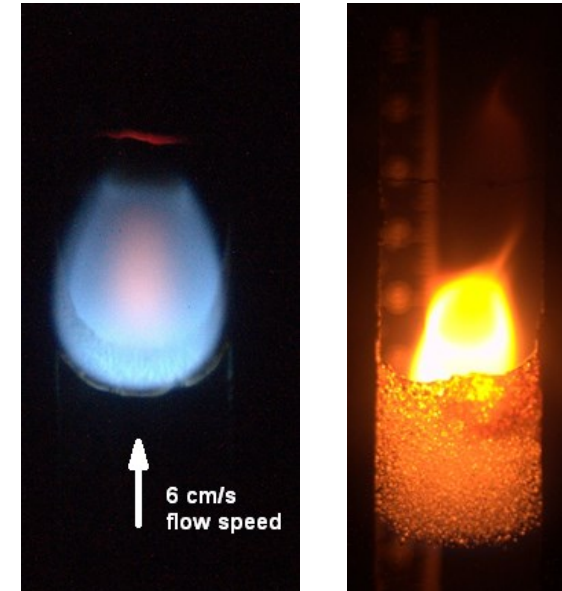

Flames in μg from BASS experiments.

Left: Flames at lower opposed flow velocities appear mostly blue

Right: Flames of this nature were observed during flow transitions and when bubbles in the plastic material burst and disturbed the flow. The high soot concentration glows bright orange casting a lot of light and makes the bubble layer in the plastic slab easily visible.

PI: Subrata (Sooby) Bhattacharjee, San Diego State University, San Diego, CA
International Co-I: S. Takahashi and K. Wakai (Japan)

Objectives:

- Radiative quenching in terms of the critical flow velocity of the oxidizer and critical thickness of fuel (PMMA sheets) in a microgravity environment using experiments, theory, and computational model.
- Delineating the thermal and concentration fields through microgravity experiment and numerical results.
- Complementary 1-g tests.

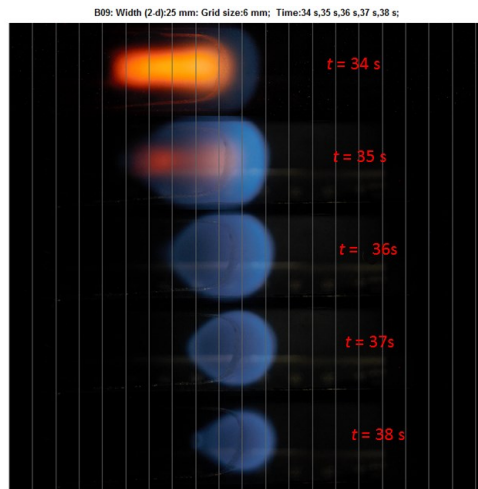

Left: radiative quenching when flow velocity goes below 2 cm/s. Right: Flame nearing blow off extinction as the flow velocity crosses 40 cm/s. (0.1-mm-thick PMMA)

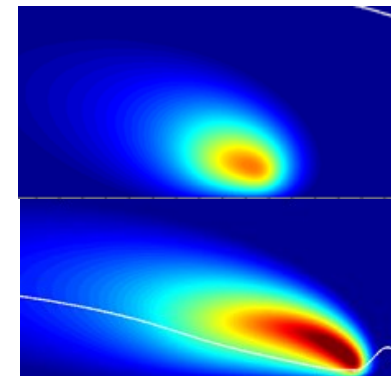
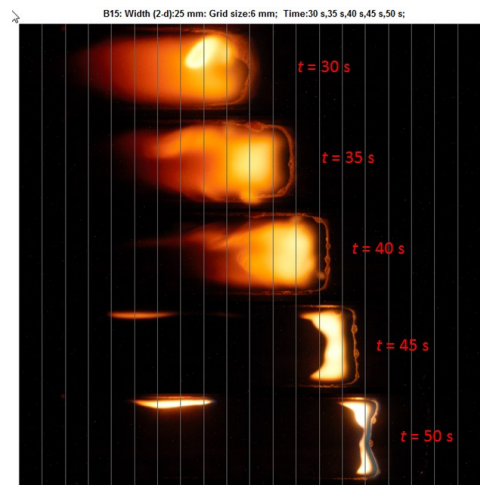

Side views of the computational flames over a thin PMMA sheet in μg in air.

PI: James S. T'ien, Case Western Reserve University, Cleveland, Ohio

Co-Is: Paul Ferkul, USRA/NASA GRC; Sandra Olson, NASA GRC

International Co-I: Oleg Korobeinichev, Inst. of Chem. Kinetics and Comb., Siberian Branch Russian Academy of Sciences, Novosibirsk, Russia

Objectives:

- Flame growth characteristics over PMMA spheres as a function of flow velocity, oxygen percentage, pressure and the degree of internal heating.
- Flame extinction characteristics (quenching and blowoff limits) over a thick solid fuel as a function of flow velocity, oxygen percentage, pressure and the degree of internal heating.
- Detailed numerical model that can be compared with the microgravity results to connecting normal gravity and 1-g.

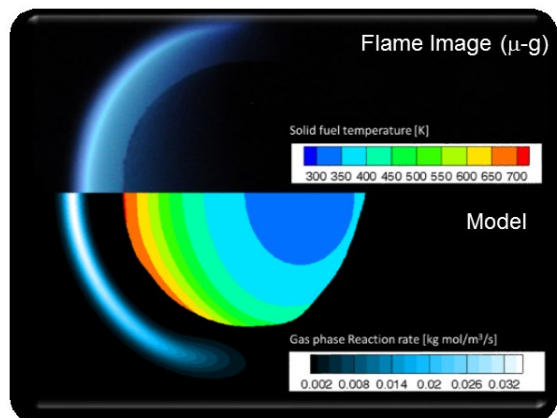
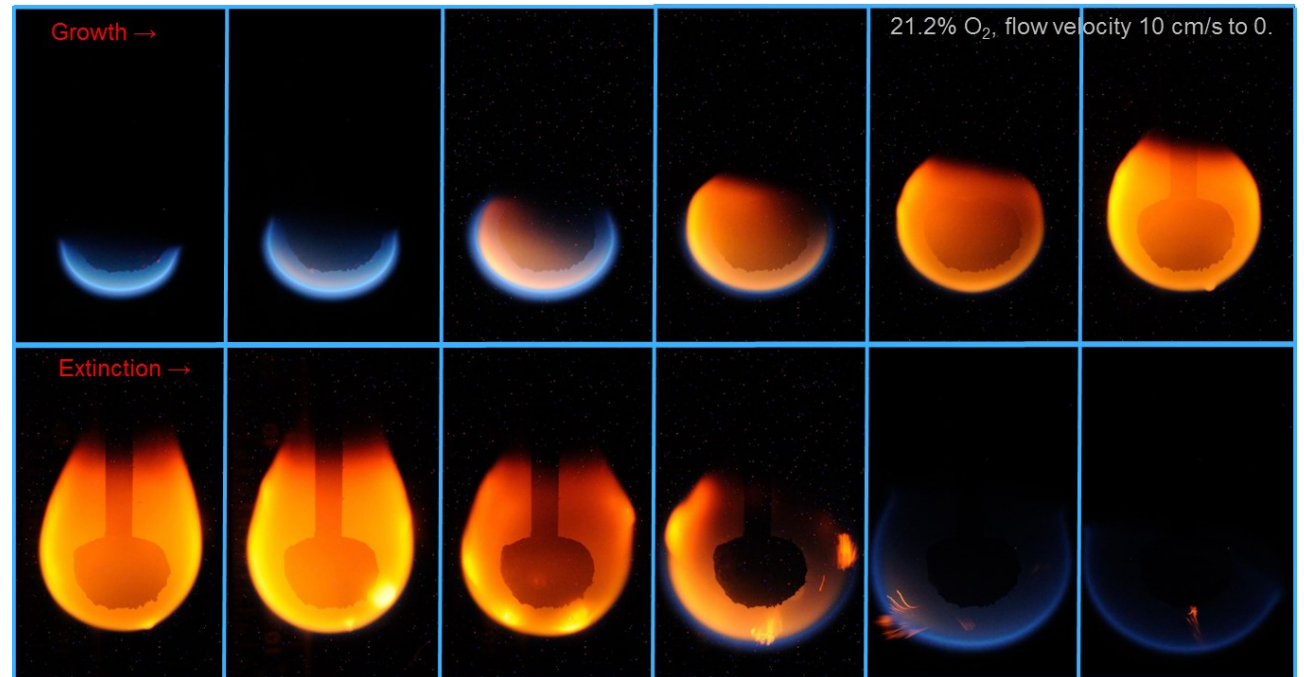



SoFIE Concept (Semi-transparent)

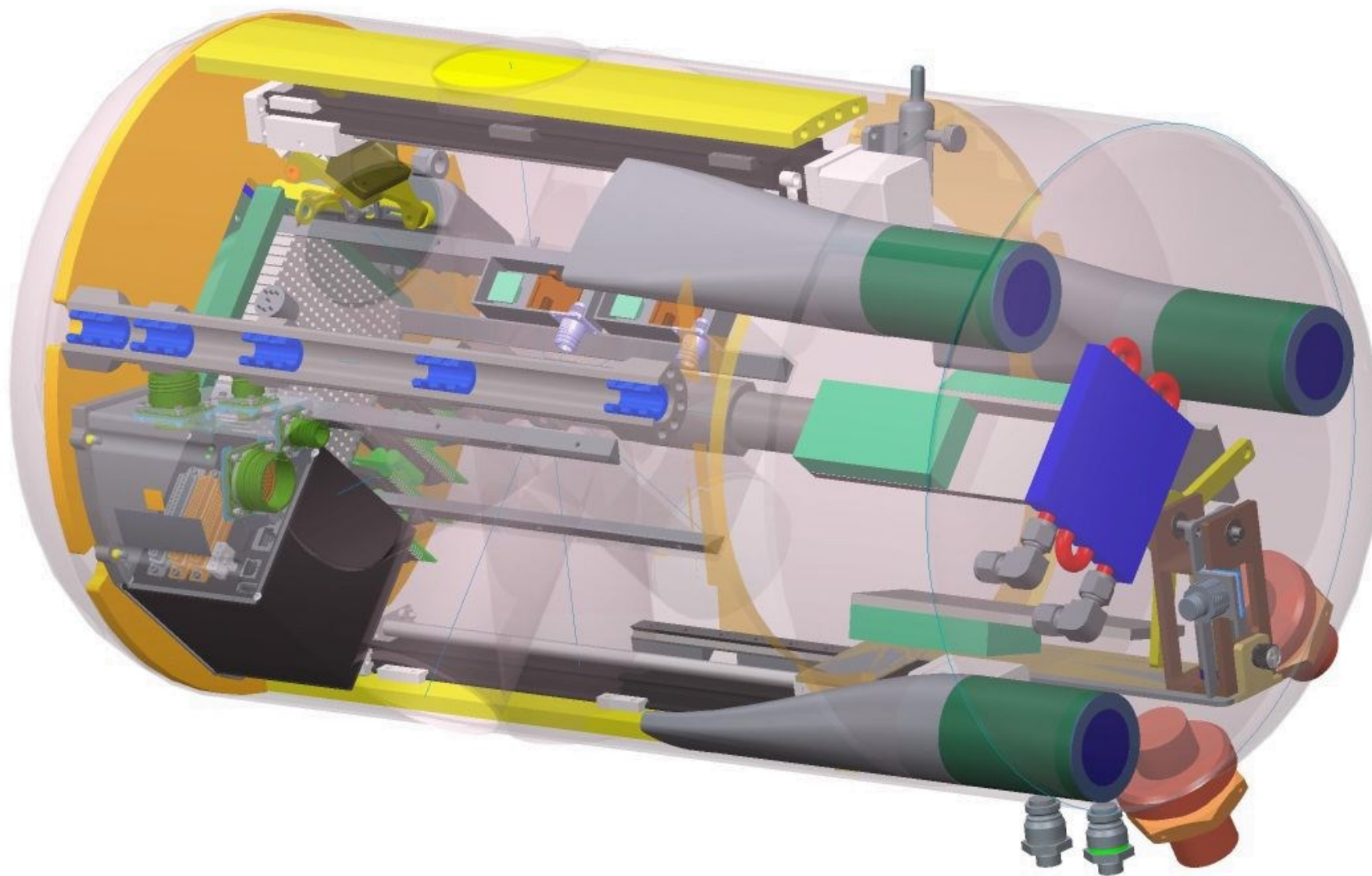
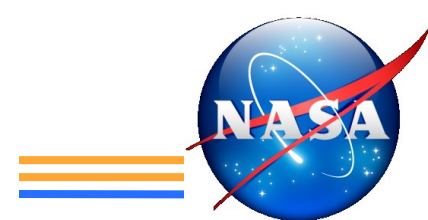

Push air through the duct

Filters installed on all fan inlets to help with soot contamination issues

Recirculation ducts on the outlet end to aid mixing and minimize inlet flow disruption

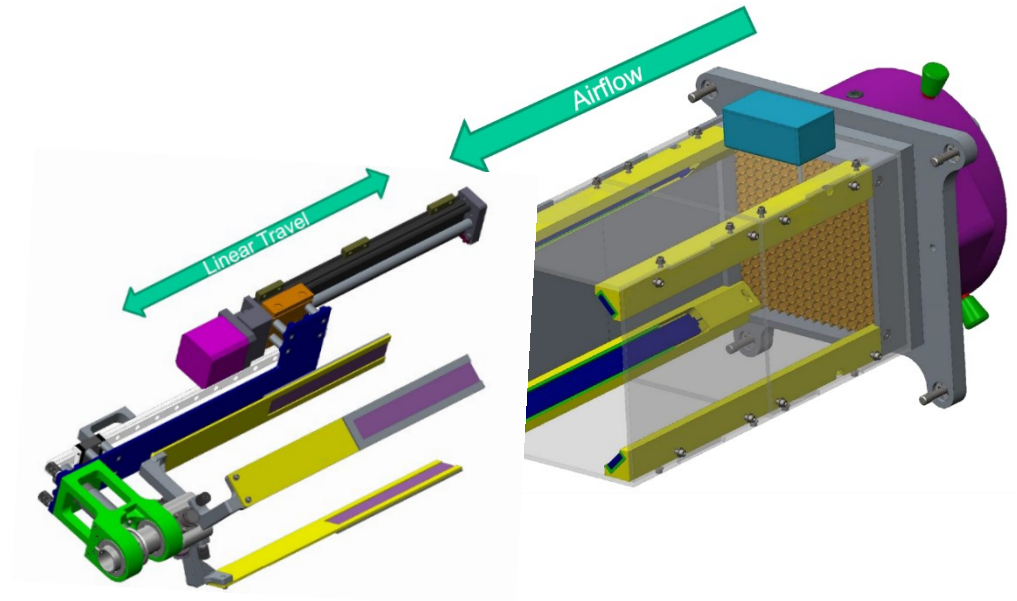
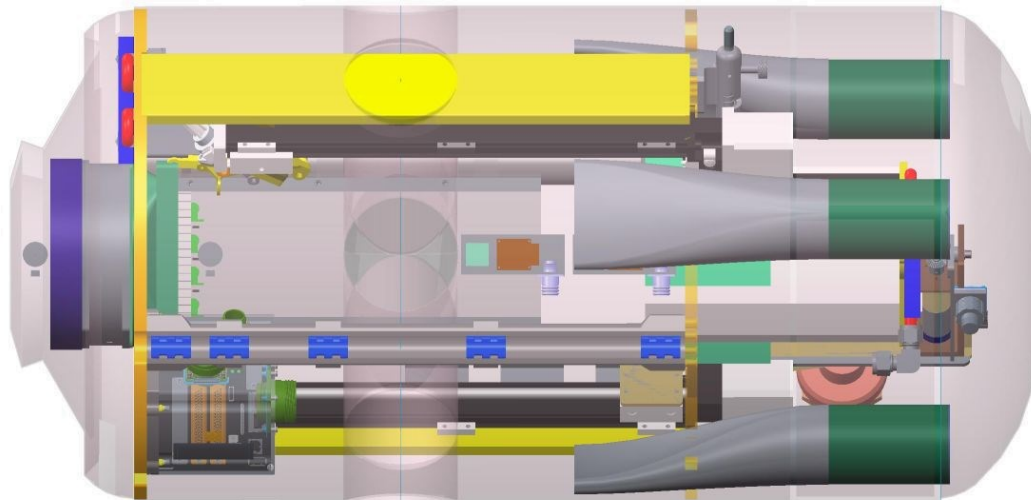



Igniter Positioning/Control



Igniter deployment motors are used to place igniter element in the correct location

Cameras will be used to verify placement

24 AWG Kanthal, with a variety of shapes

Igniter current is specified and controlled.

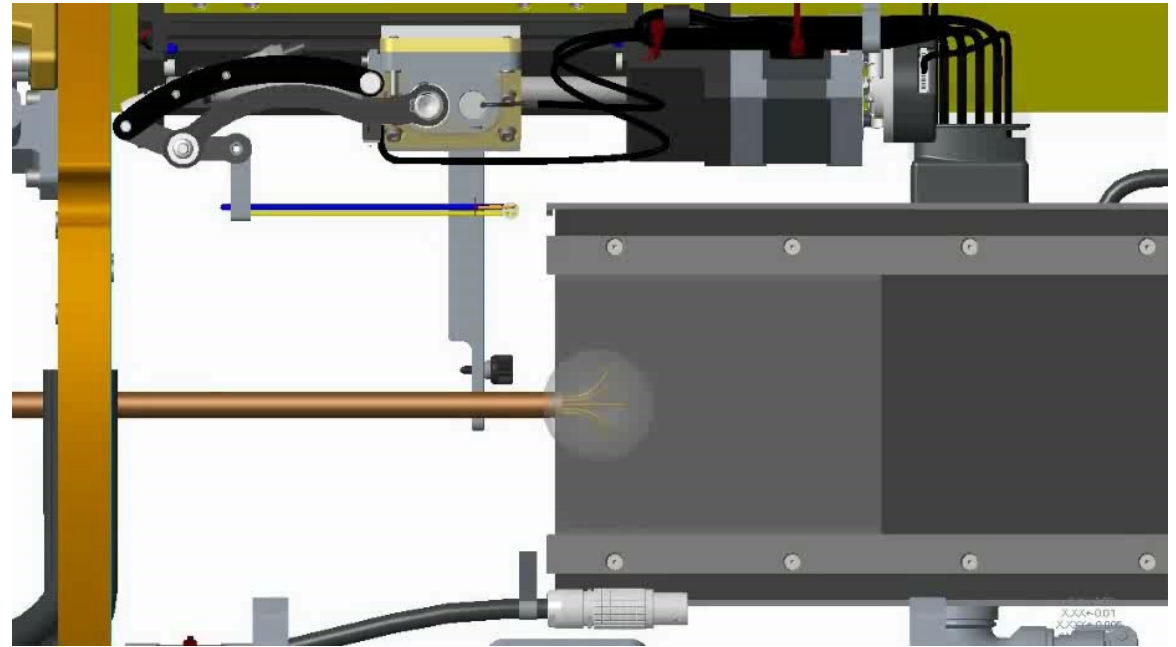

Front view

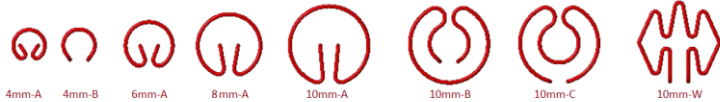

Top view



Perspective view

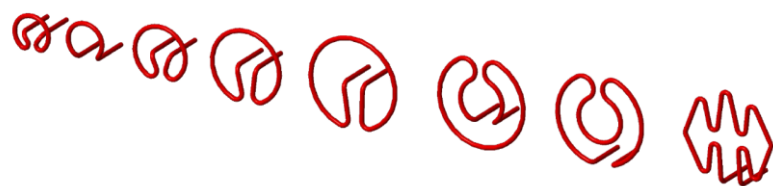

Two internal and one external camera image the entire flow tube and sample

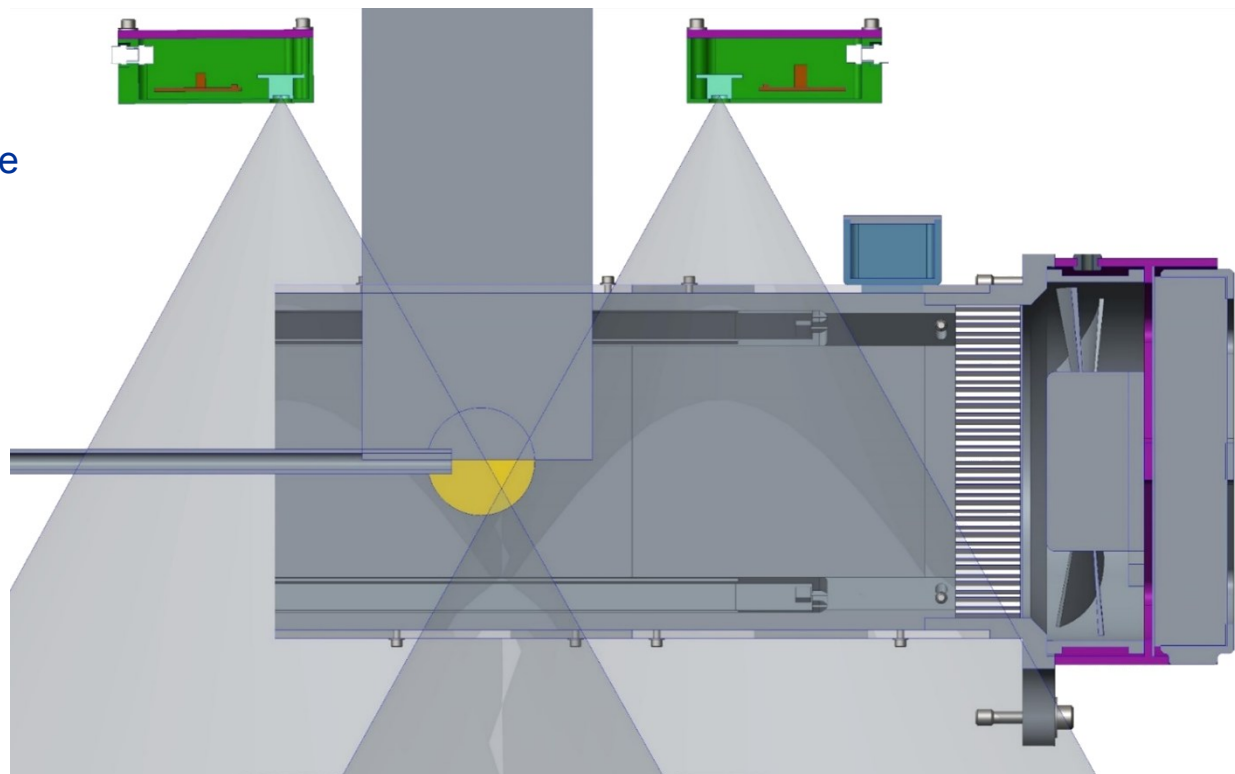
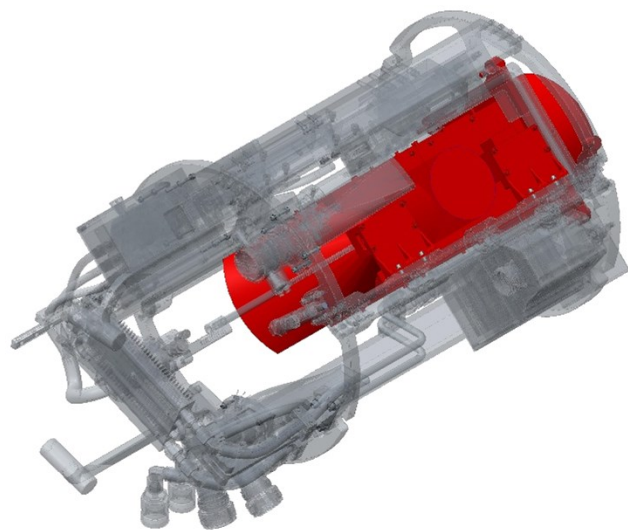



Experiment Samples

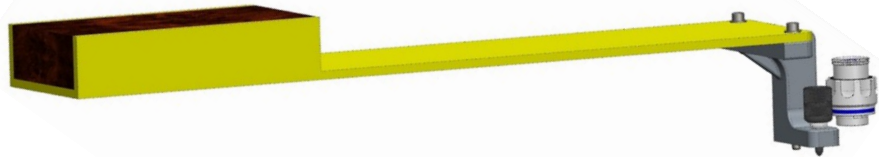

NCA (10 cm x 5 cm x 1 cm block)



SMuRF (30 cm rods)

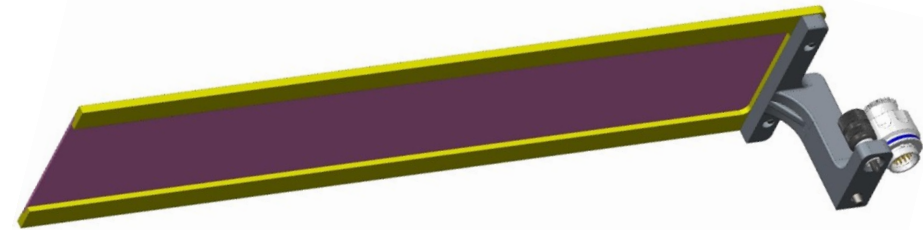

RTDFS, SMuRF (30 cm x 5 cm flat thin)

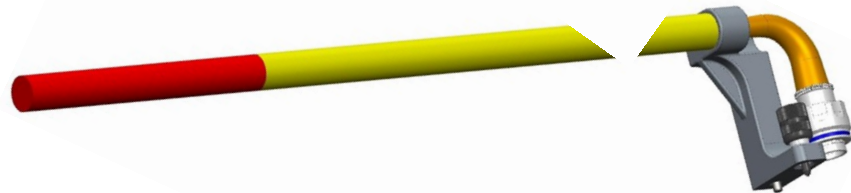

MIST 15 cm rods

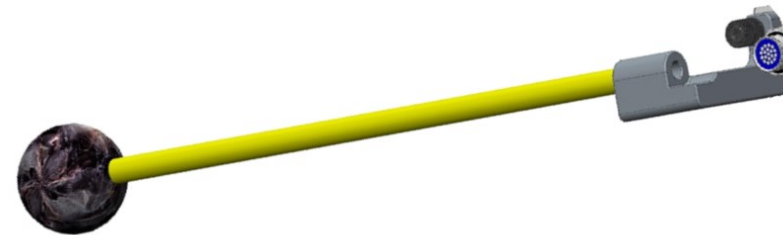

GEL (40 cm-dia sphere)



SoFIE Sample Resources



- RTDFS
 - 24 samples – thin sheets
 - 3 samples in chamber
 - 1 test per sample
 - 8 chamber accesses
 - No flow tube
- MIST
 - 22 samples – rods
 - 3 samples in chamber
 - 1 test per sample
 - 8 chamber accesses
- NCA
 - 20 samples – slabs
 - 3 samples in chamber
 - 1 test per sample
 - 7 chamber accesses
- SM μ RF
 - 43 samples
 - 10 rods
 - 33 sheets
 - 3 samples in chamber
 - 2 tests per rod, 1 test per sheet
 - 15 chamber accesses
- GEL
 - 15 samples – spherical
 - 1 sample in chamber
 - 3 tests per sample
 - 15 chamber accesses

- Ceramic radiant heaters, max 800W
- Heater power and temperature adjustable

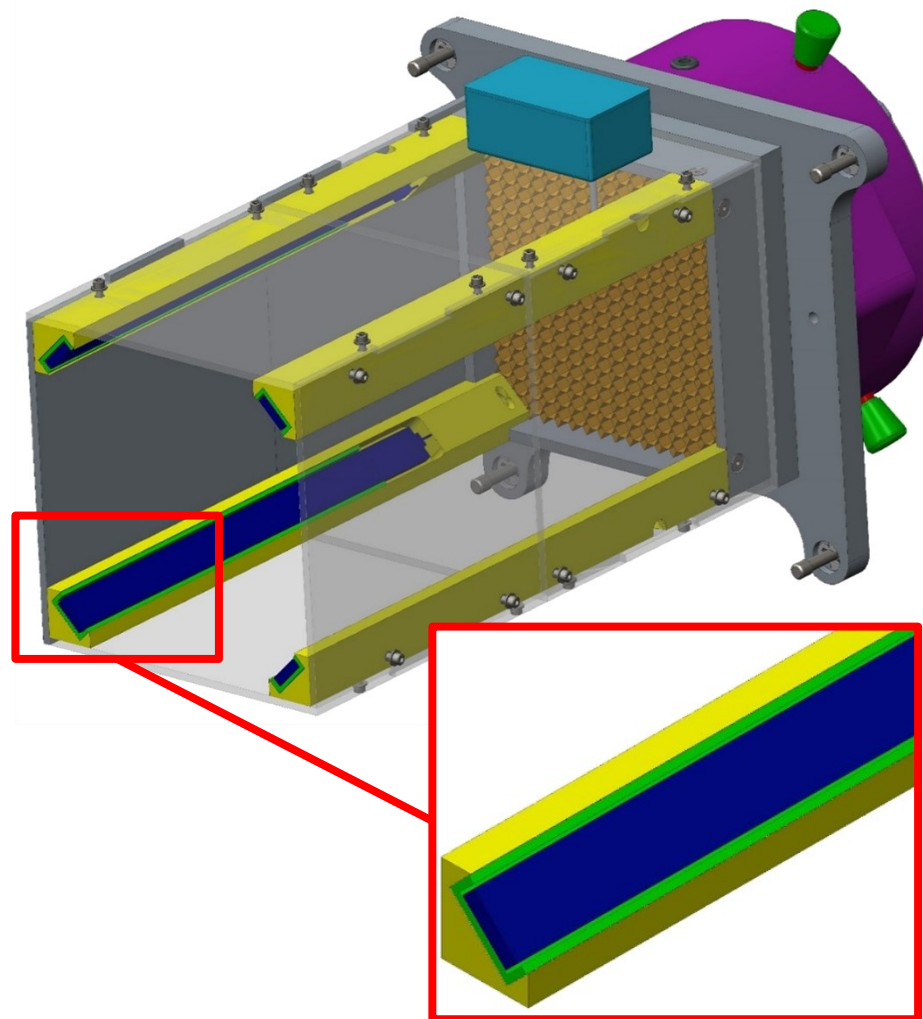
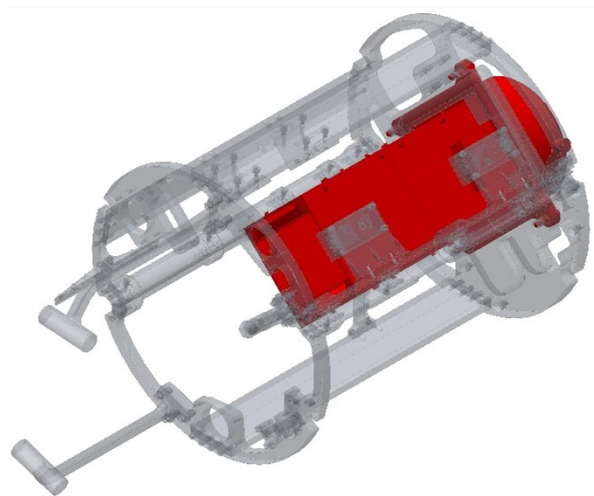

- The Igniter System has two positioning motors
- Haydon-Kerk G4 Motor (similar to ACME) provides rotation into position
- Velmex XN-10 linear slide moves the igniter in and out of the flow duct

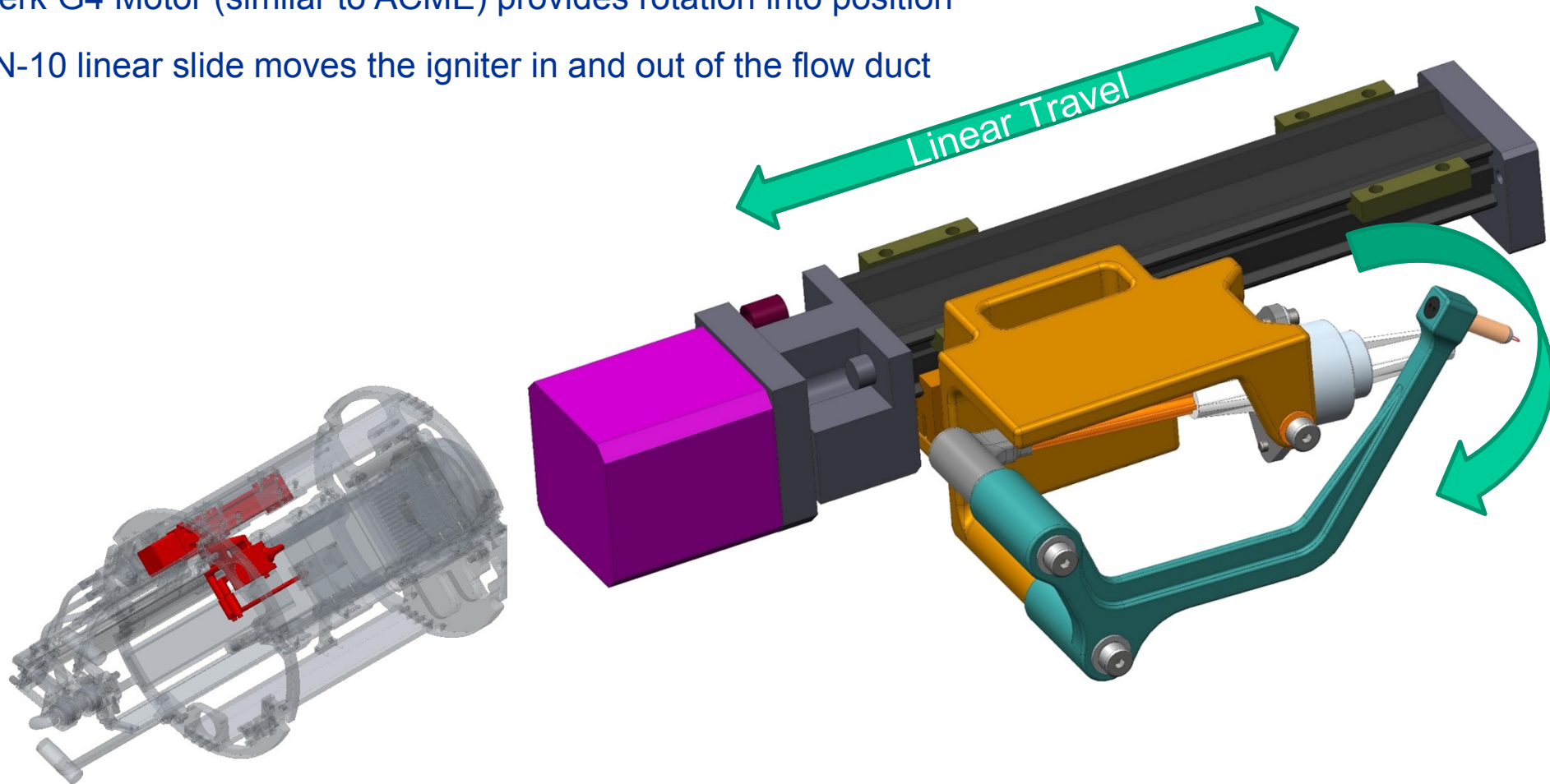



GRC ISS Physical Sciences Research Combustion Integrated Rack (CIR) Payload Utilization Schedule

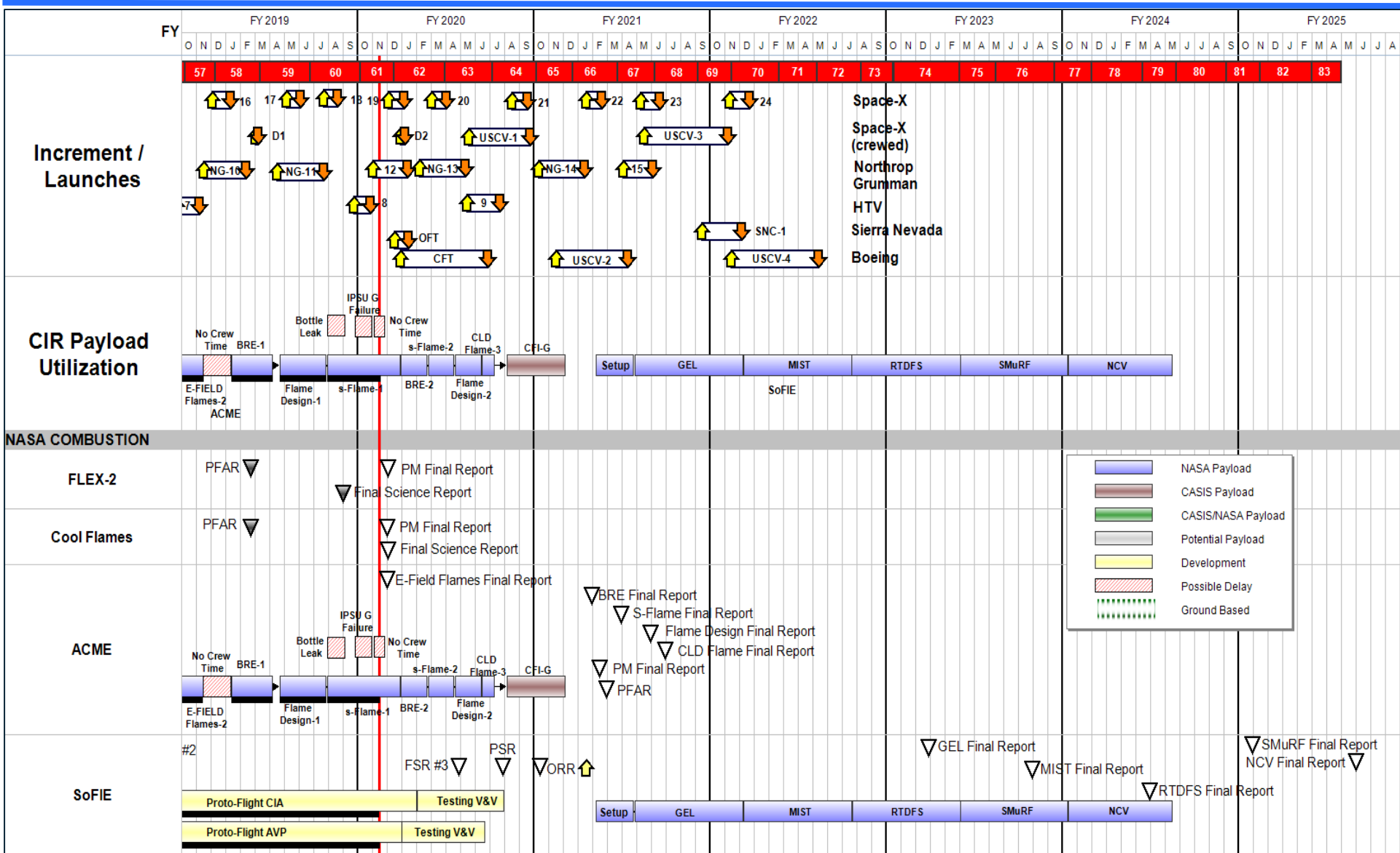

	NASA Payload
	CASIS Payload
	CASIS/NASA Payload
	Potential Payload
	Development
	Possible Delay
	Ground Based



Pre-Test Crew Setup



- Open doors. Translate the Optics Bench out and rotate the bench down.
- Install CIR and/or PI specific diagnostics along with SoFIE Avionics Package
- Rotate Optics Bench up and translate into the rack
- Open chamber, replace fan, install the configured SoFIE insert, close chamber
- Install gas bottles and adsorber cartridge, open gas valves
- Close rack doors

Step 1
Fold Open Door

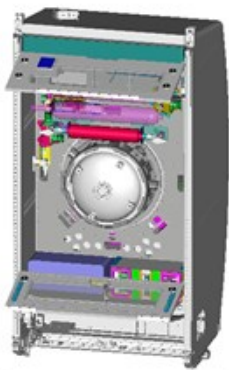

Step 2
Retract Pins

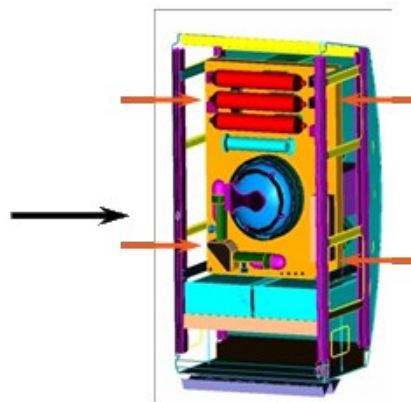

Step 3
Translate Optics bench,
Fold Down Optics Bench

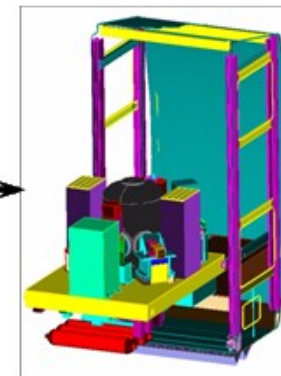

Powered
screwdriver
required

Step 4
Unstow/Install Payload Specific,
Diagnostics/Electronics

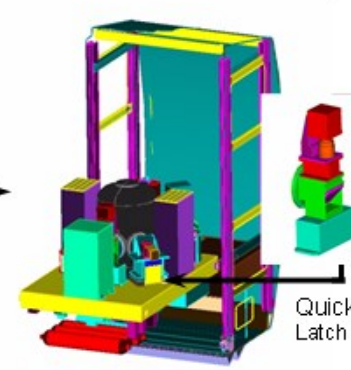

Step 5
Fold Up Optics Bench,
Engage Pins

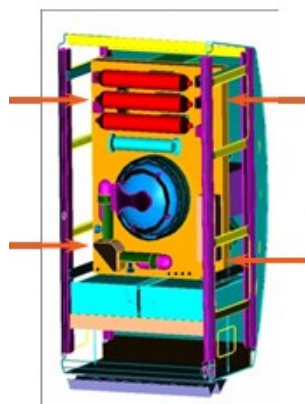

Step 6
Open Chamber,
Unstow/Install Payload
CIA



Step 7
Close Chamber

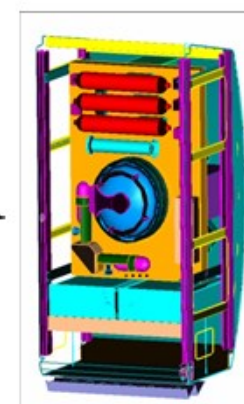

Step 8
Install Bottles and Filters

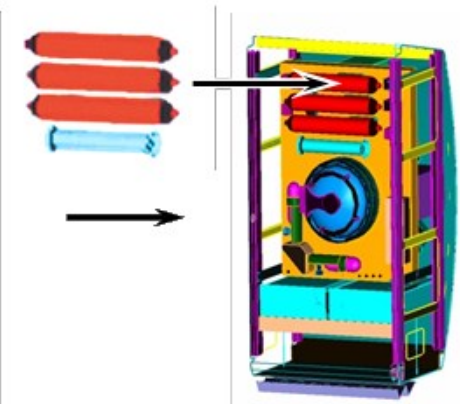



SoFIE Nominal Powered Ops



1. CIR undergoes a self-test
 2. Chamber is evacuated and filled with nitrogen to test for leaks
 3. Test points are run (details on next slide)
 - a. Chamber is evacuated and filled with mix of gases for test point operations
 - b. SoFIE specific hardware is powered
 - c. Test point ignited / data captured
 - d. Chamber contents are analyzed, processed and vented
 - e. High-resolution video images are downlinked for analysis
 4. Crew changes test samples or other hardware as needed
 5. Test points are repeated until science matrix is complete
-



General Test Point Sequence



- Fill chamber per specific test point requirement
- Sample atmosphere using CIR Gas Chromatograph (GC)
- Configure CIR and SoFIE cameras and illumination
- Start SoFIE circulation fan (wait period to allow flow to establish)
- Preheat sample if needed (radiant heaters)
- Ignite sample and run SoFIE test sequence with data acquisition
- Monitor CIR systems (digital data storage, cameras, gas fill and scrub, chamber)
- Add O₂; filter chamber contents during test as needed
- Flame extinguishes
- Close any and all flow paths open
- Sample atmosphere (GC)
- Turn off circulation fan