

# A multi model electromagnetic sounding investigation of the lunar interior



**Heidi Fuqua Haviland**

[heidi.haviland@nasa.gov](mailto:heidi.haviland@nasa.gov)

**NASA Marshall Space Flight Center  
Heliophysics and Planetary Science Branch**



**Fuqua Haviland, H.**, Delory, G. T., de Pater, I. (2019). Finite Element Analysis for Lunar Electromagnetic Sounding. *Advances in Space Research*. doi.org/10.1016/j.asr.2019.05.006

**Fuqua Haviland, H.**, Poppe, A. R., Fatemi, S., Delory, G. T., & de Pater, I. (2019). Time-dependent hybrid plasma simulations of lunar electromagnetic induction in the solar wind. *Geophysical Research Letters*. doi.org/10.1029/2018GL080523

Fatemi, S., **Fuqua, H. A.**, Poppe, A. R., Delory, G. T., Halekas, J. S., Farrell, W. M., Holmström, M. (2015). On the confinement of lunar induced magnetic fields. *Geophysical Research Letters*, 42(17), 6931–6938. doi:10.1002/2015GL065576

***Emerging work for future missions including the Lunar Geophysical Network (LGN) and Commercial Lunar Payload Services, InSight***





# Driving Science Question

Equatorial Cross-section

## Near Side

## Far Side

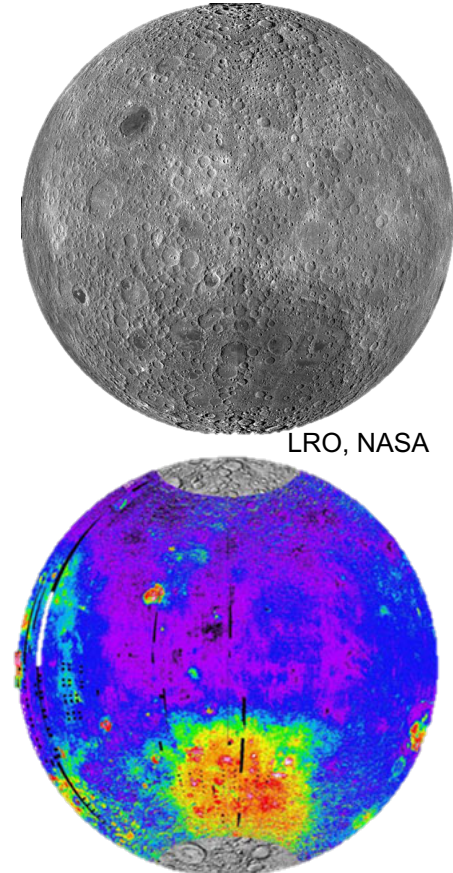
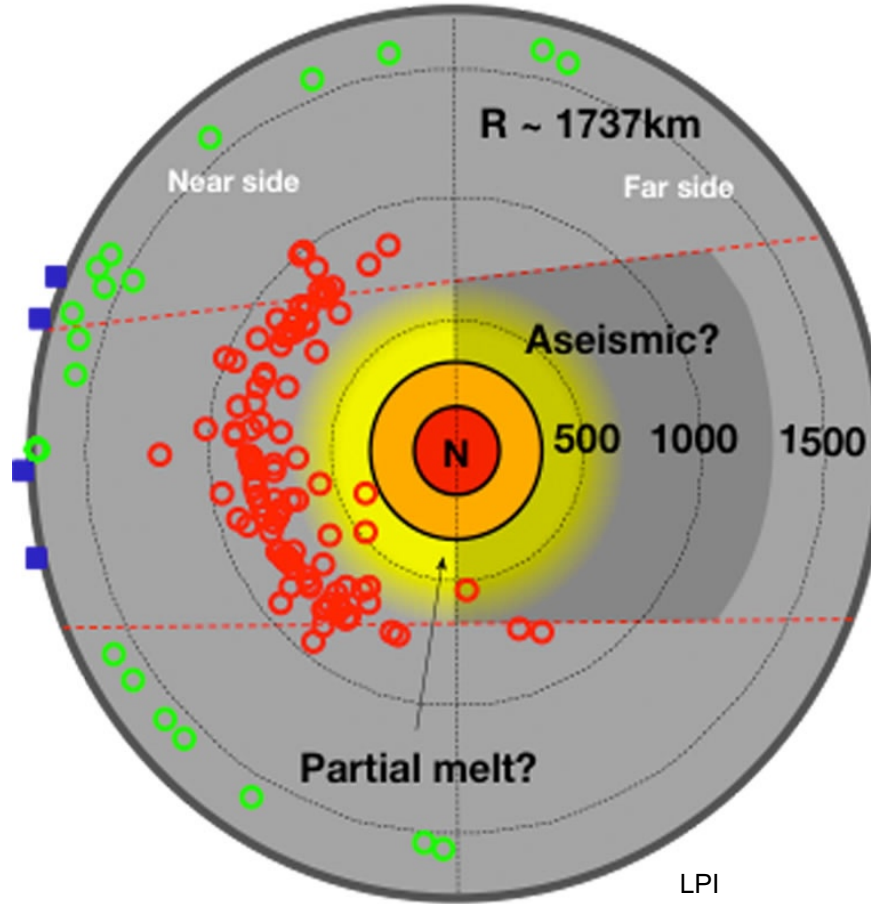
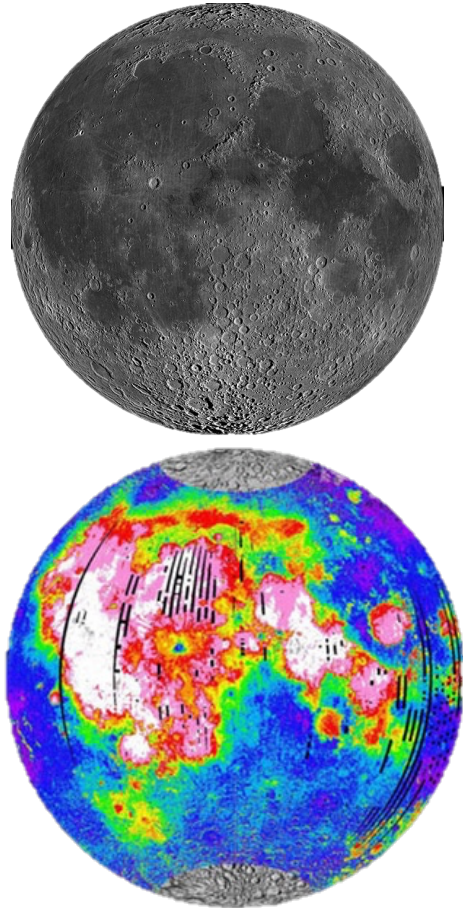

LRO, NASA

Hiesinger & Head, 2006

***What is the current state and structure of the global lunar interior?***



# Lunar Origin Theories

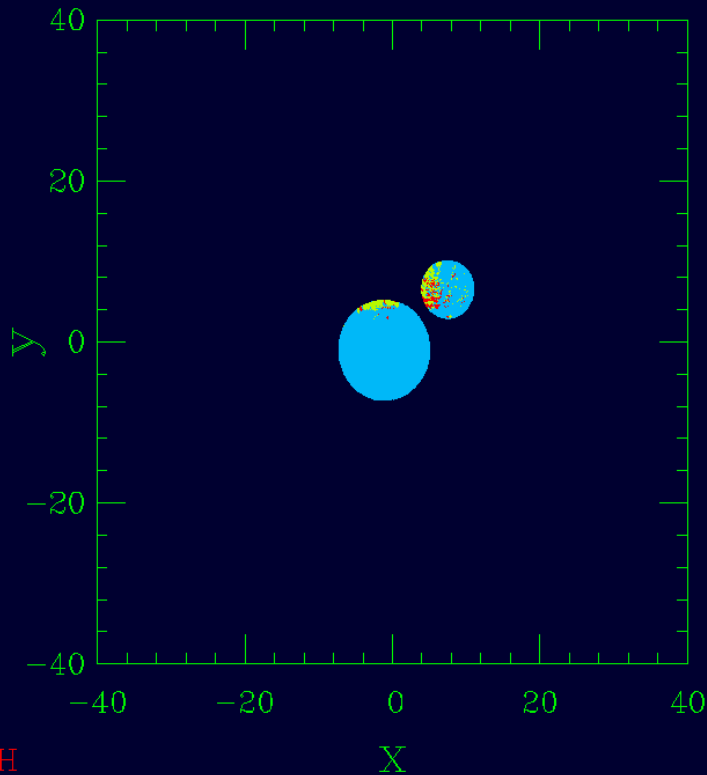

Canup et al. 2016

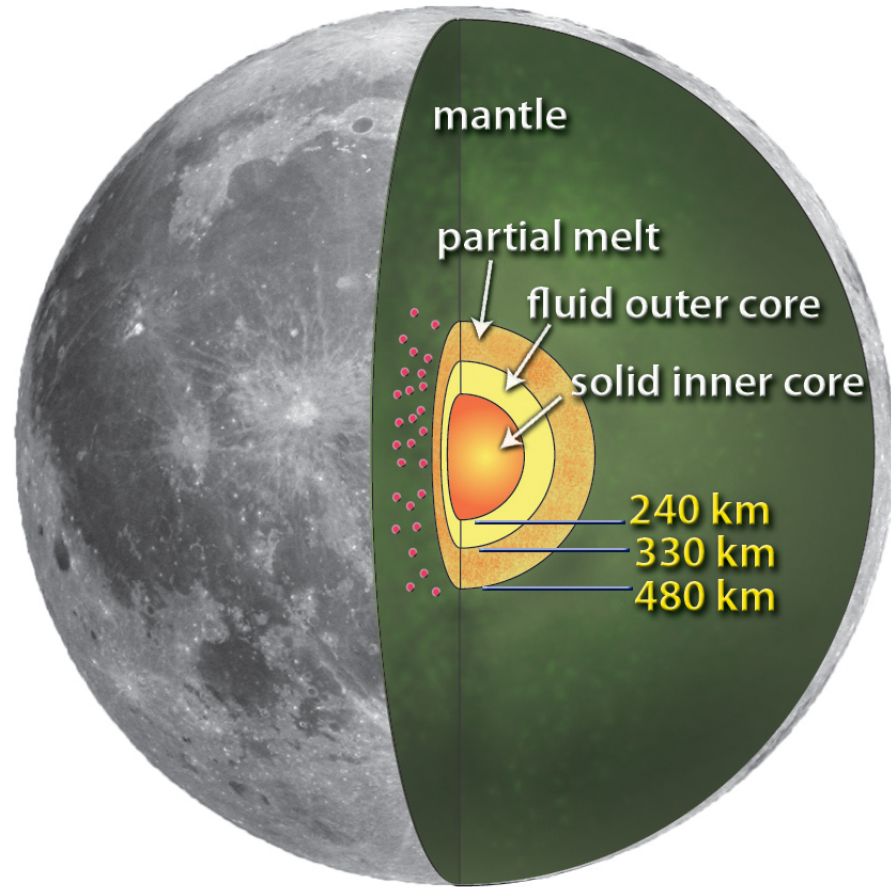

Weber et al., 2011

***The current state is key to constraining origin theories.***

# Magma Ocean Crystallization

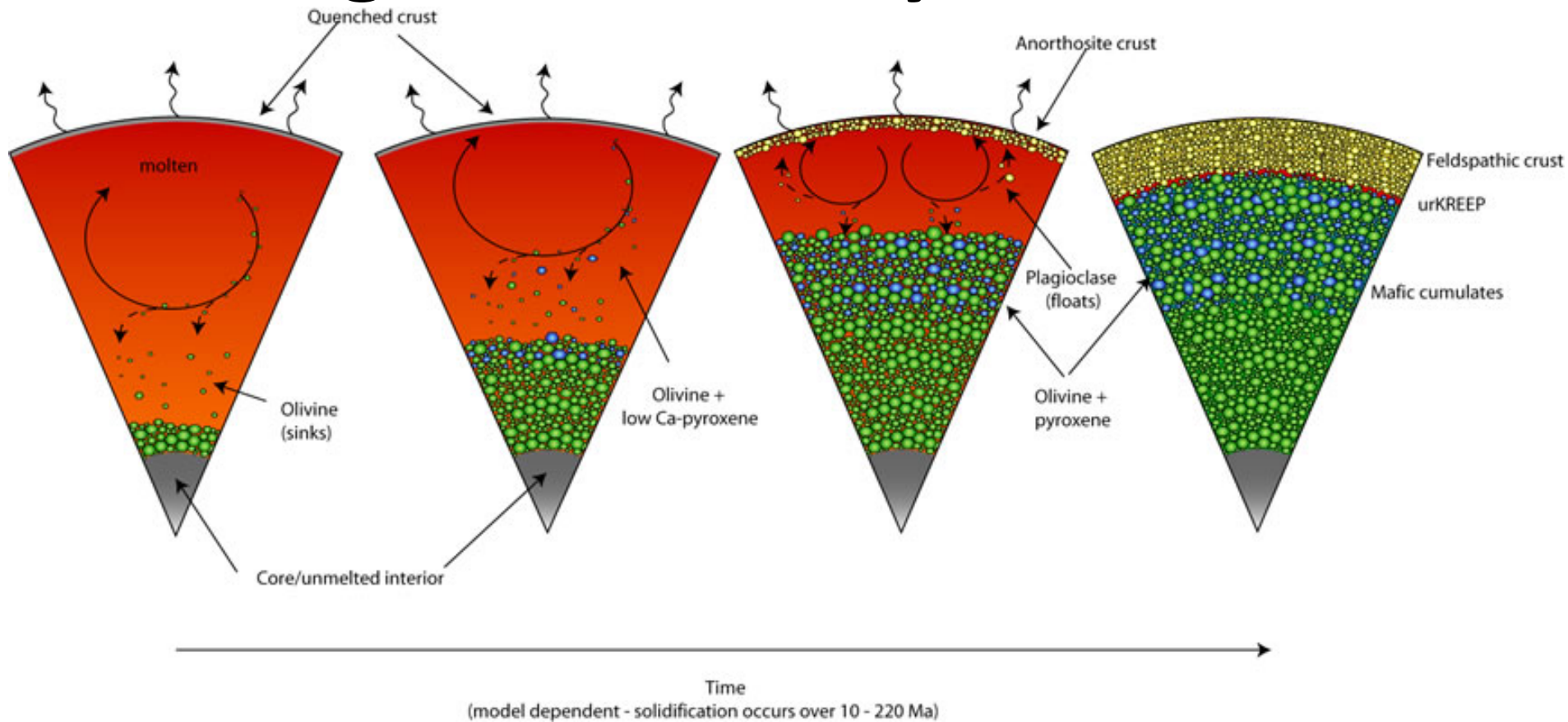
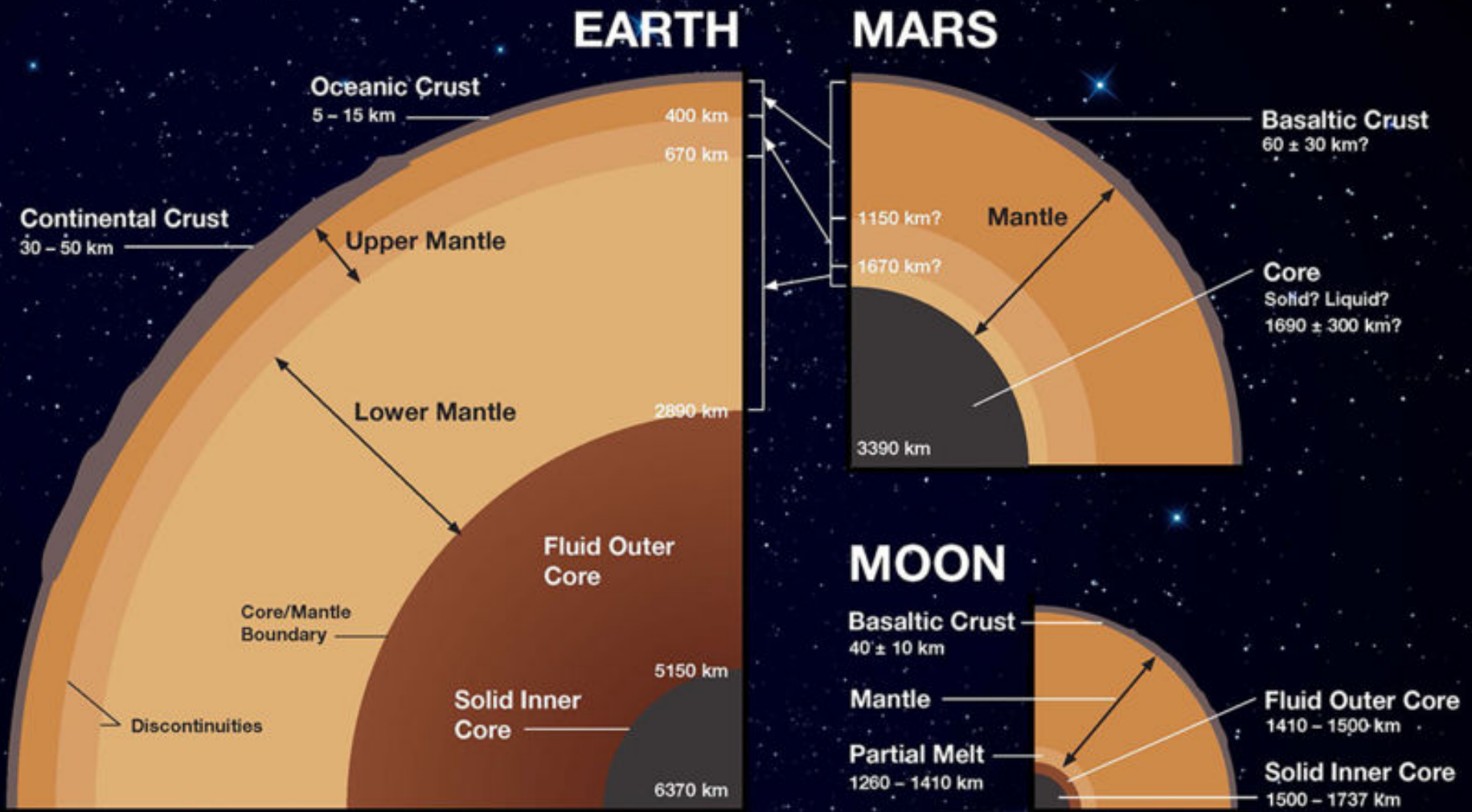

Image source: LPI

***The current state of the lunar interior is the first step to constraining formation.***



# Terrestrial Planet Interior Structure



# Key Open Questions

1. What is the lateral and vertical extent of the Procellarum KREEP Terrain (PKT) in the upper mantle?
2. What is the global extent of the discontinuities in the upper mantle?
3. Does a partial melt region exist in the lower mantle?
4. What is the nature and extent of the lunar core?
5. How do the induced fields interact with wake fields?

***EM Sounding is a powerful tool capable of constraining the electrical conductivity of the Moon, and hence, temperature, core thickness, mantle, and crust/PKT structure at depth.***

# Earth-Sun-Moon Space Environment

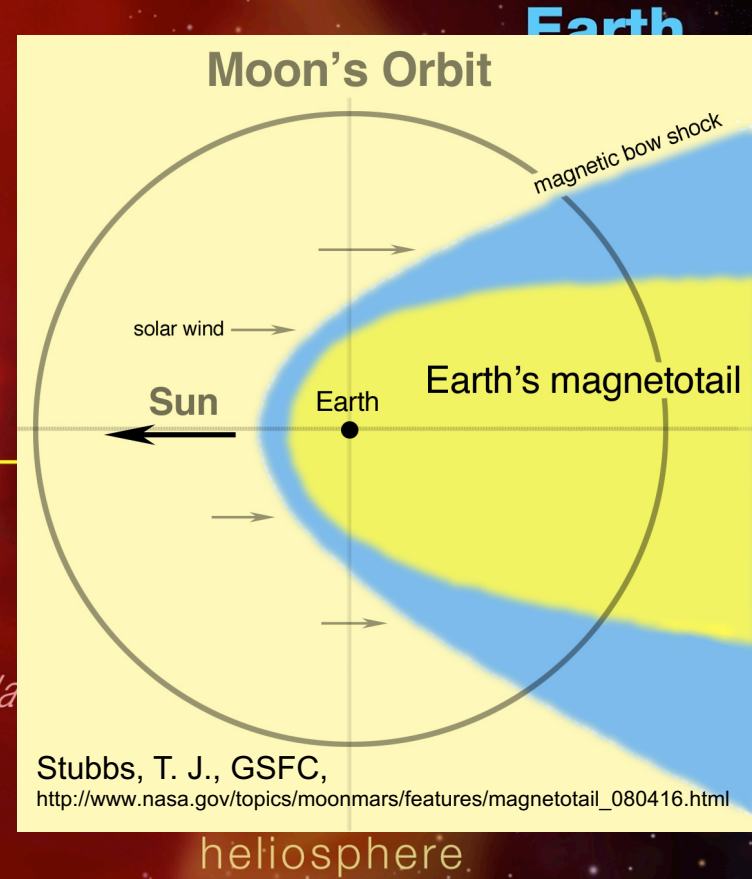
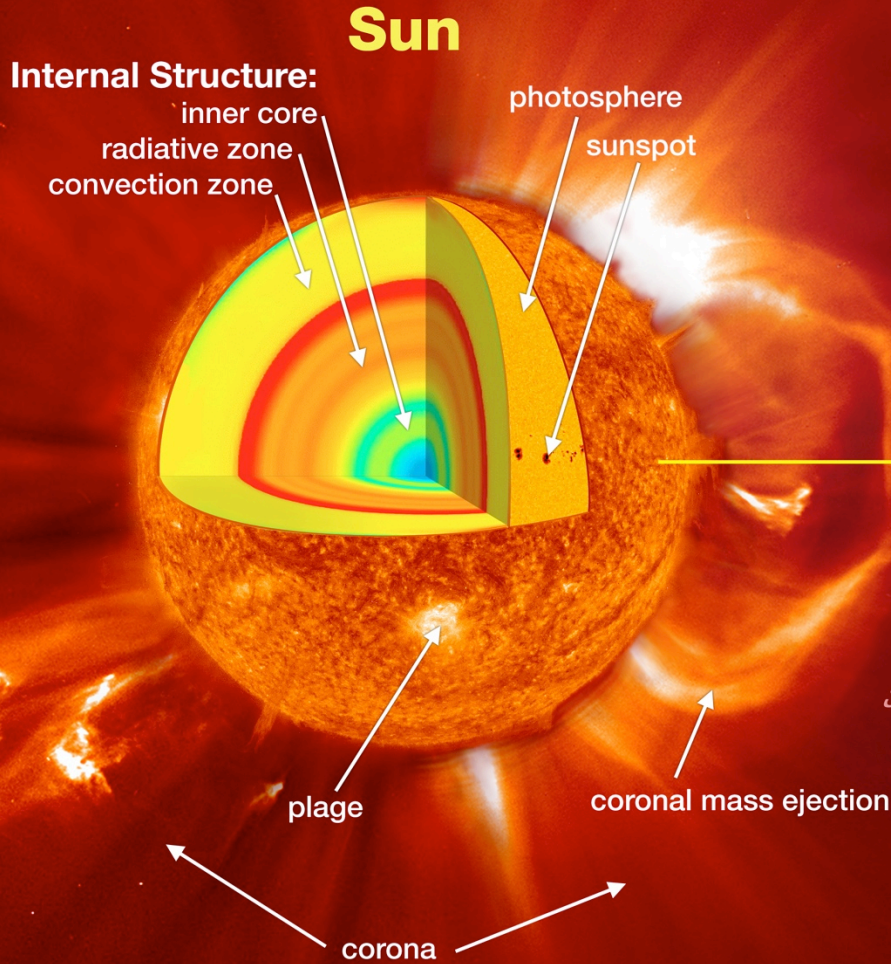

Image Source: NASA



# Solar Wind Space Plasma Environment

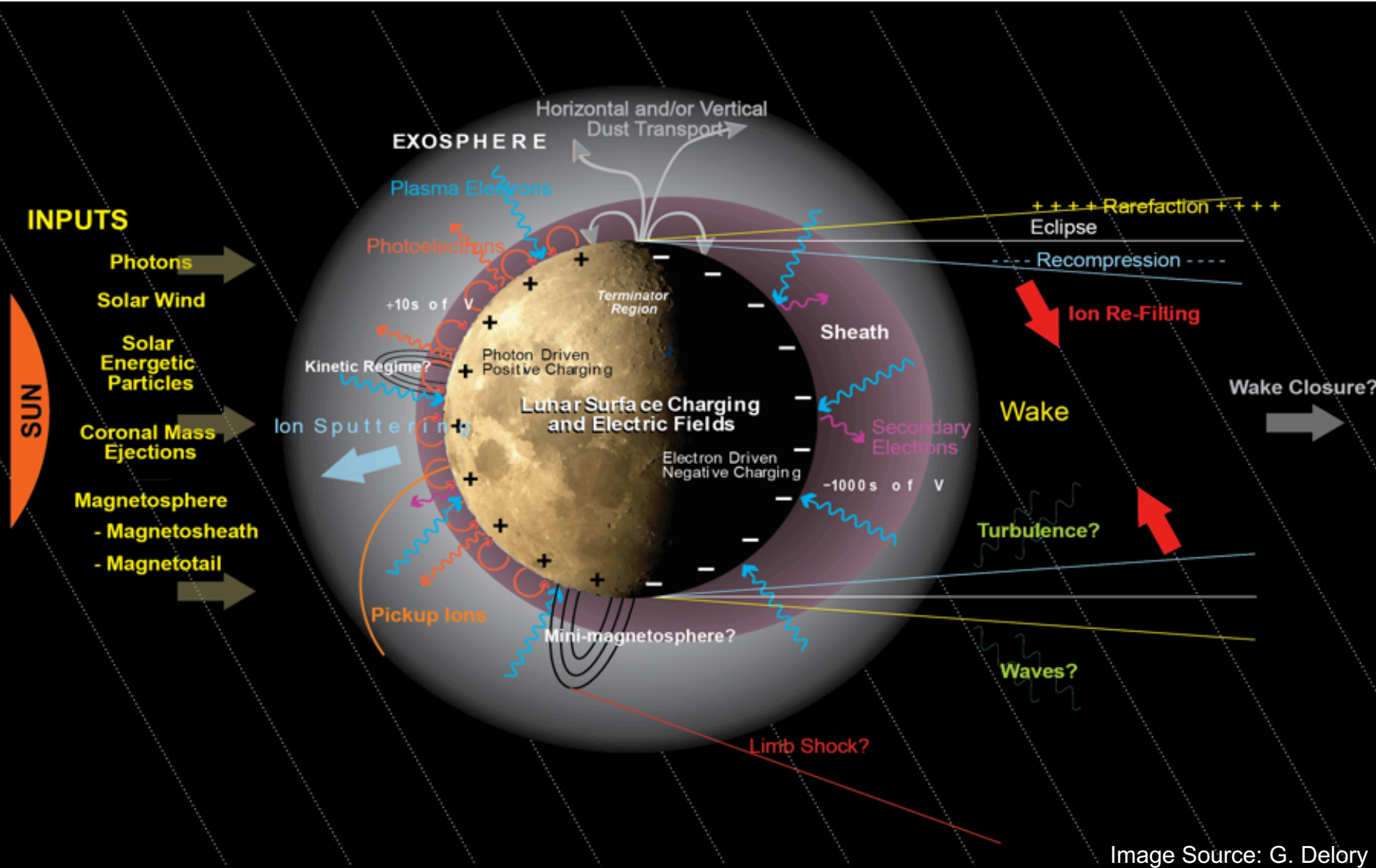
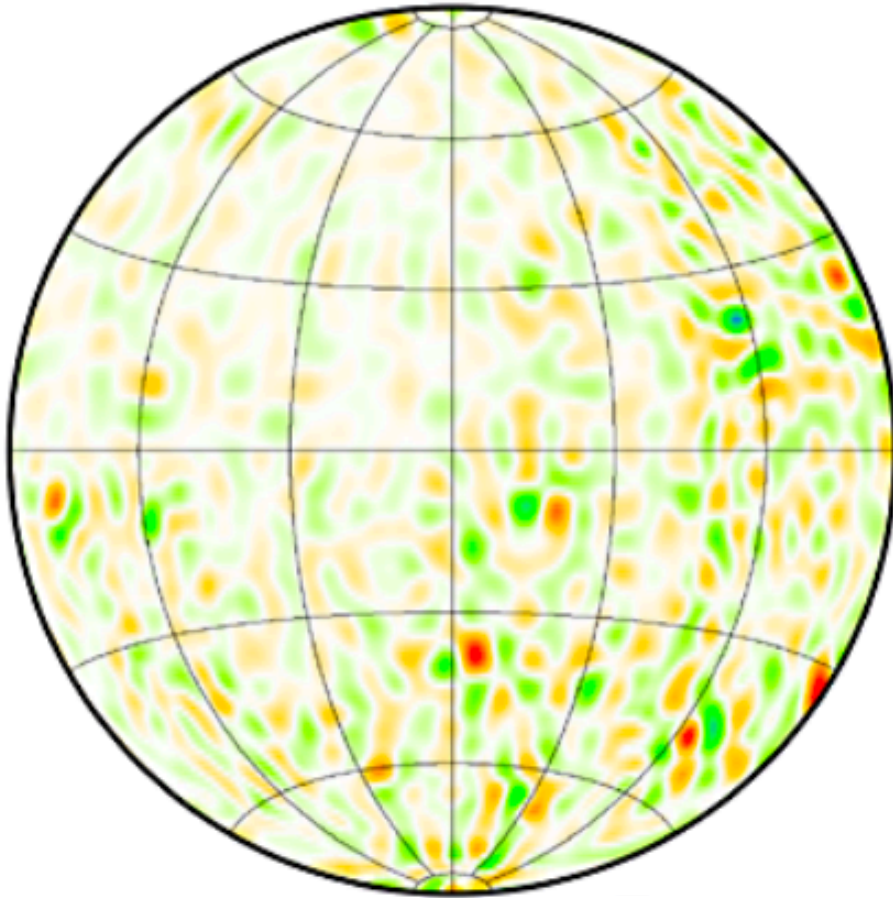

Image Source: G. Delory

# Lunar Crustal Magnetic Fields

Nearside



Farside

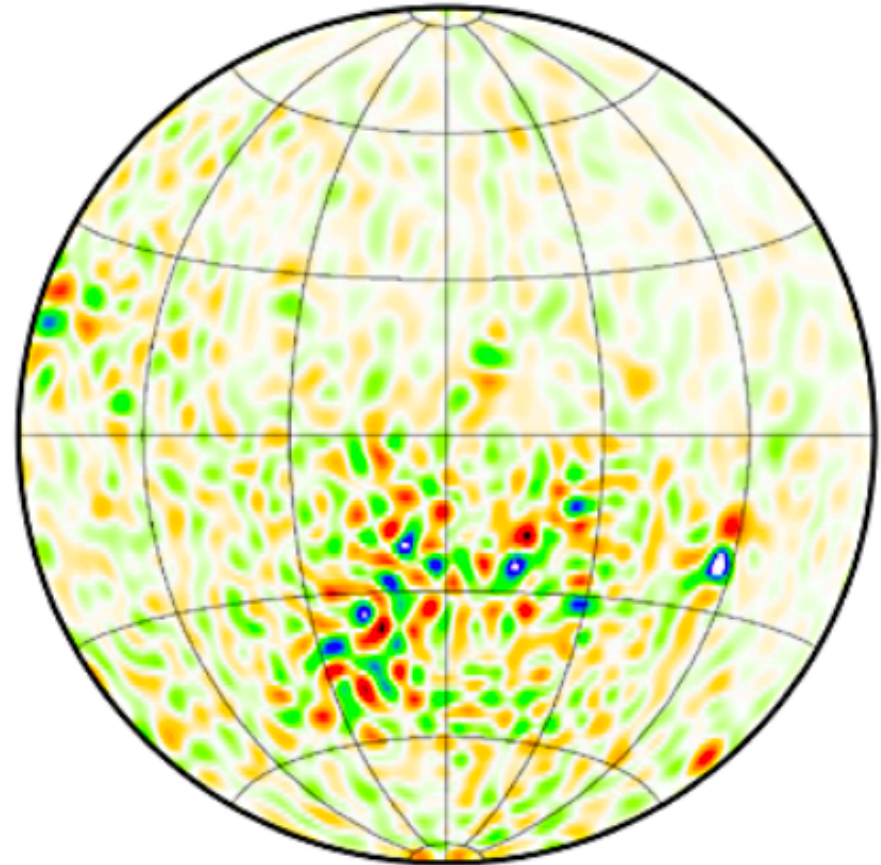

Regions of weak crustal fields are prevalent.

Equivalent surface Field Strength.

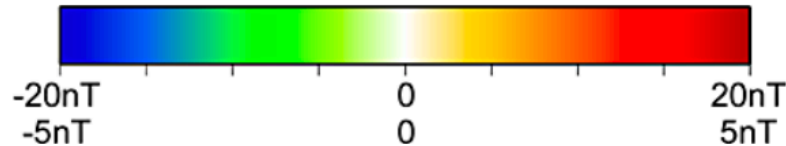

Tsunakawa et al., 2010

# Asymmetric Plasma Confinement

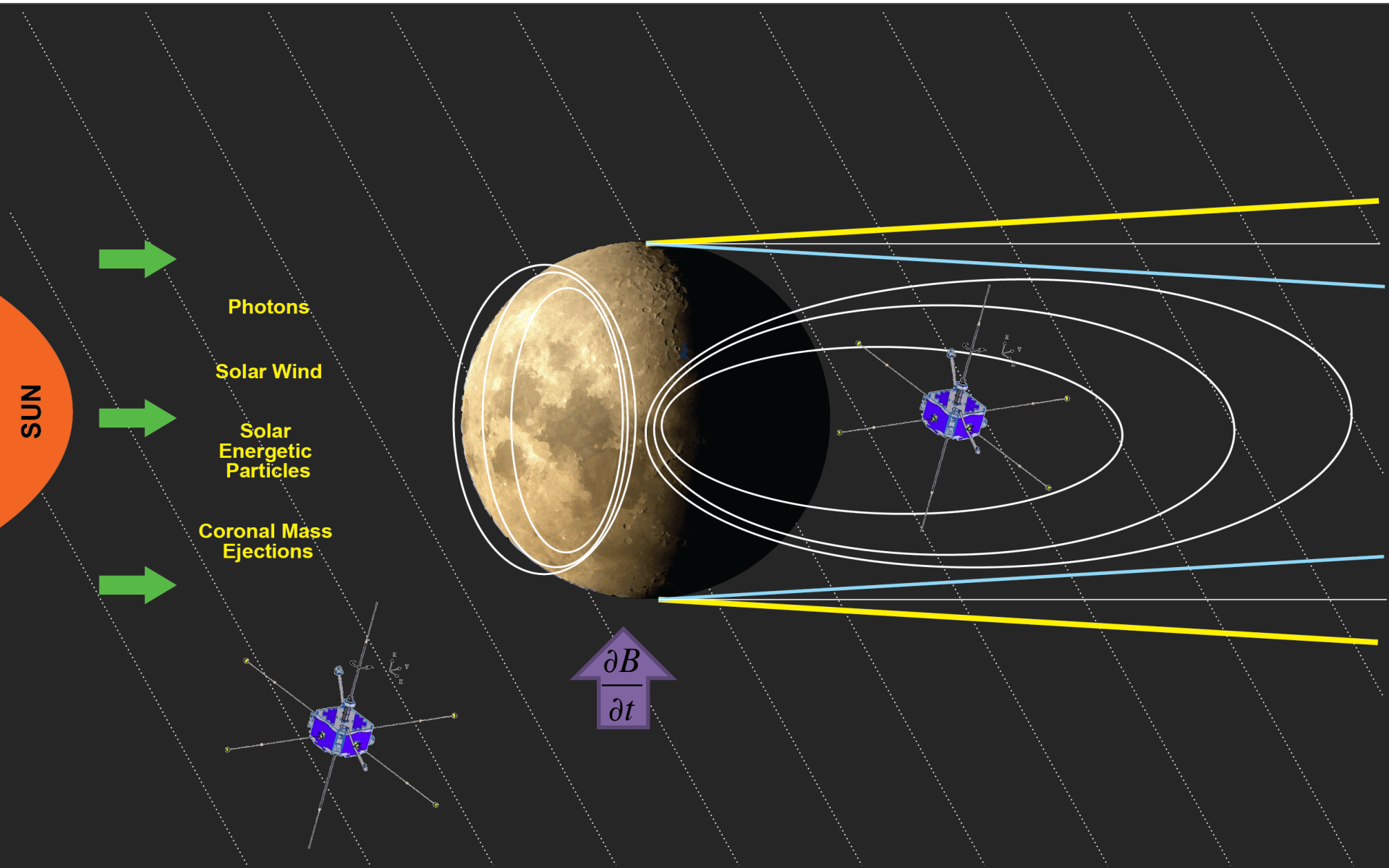

# Planetary EM Geophysical Methods

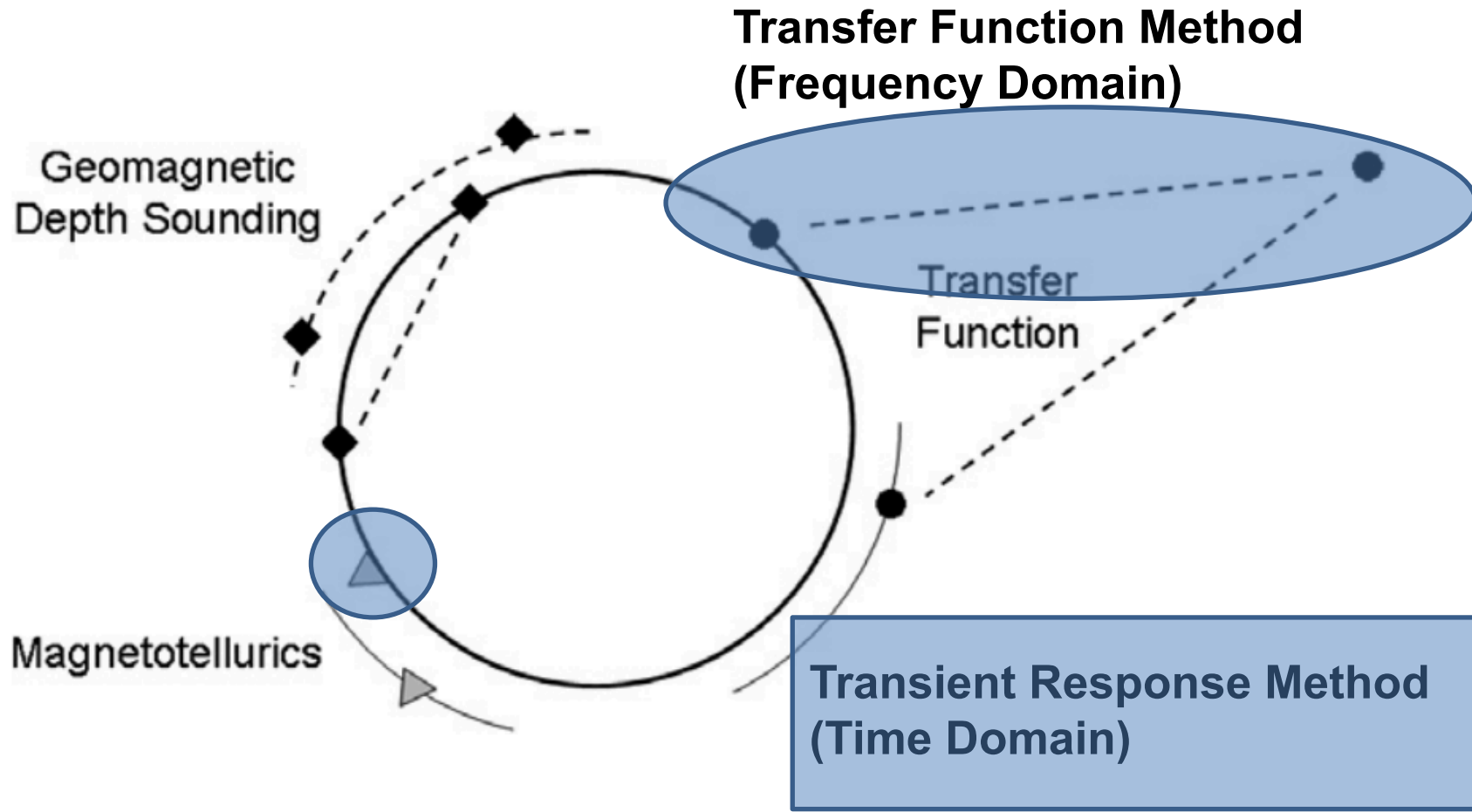

Grimm and Delory, 2012

# Lunar Electromagnetic (EM) Sounding Transient Response Method

(a) TDEM Geometry

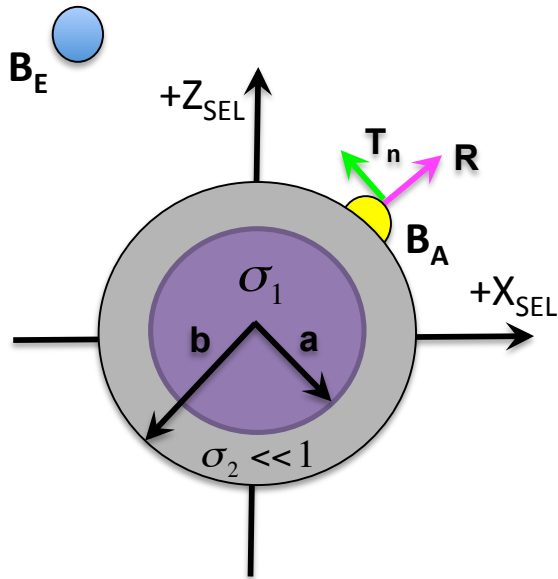

(b) Magnetotail Induction

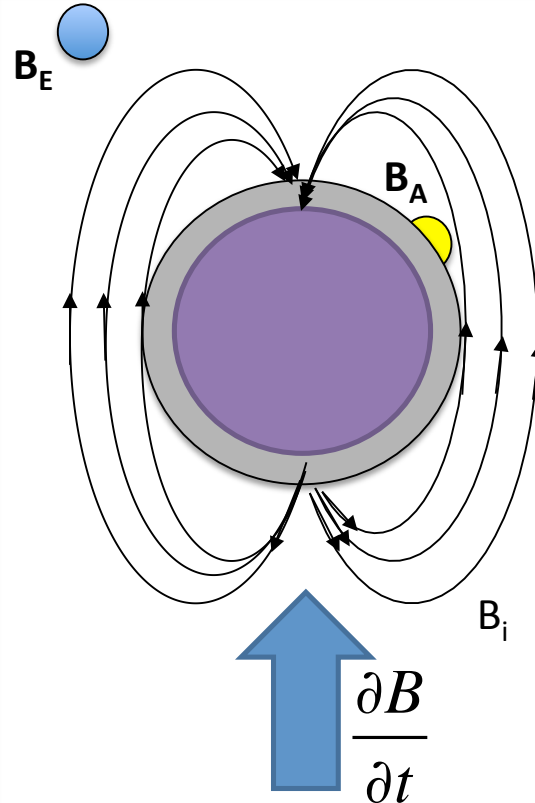

(c) Solar Wind Induction

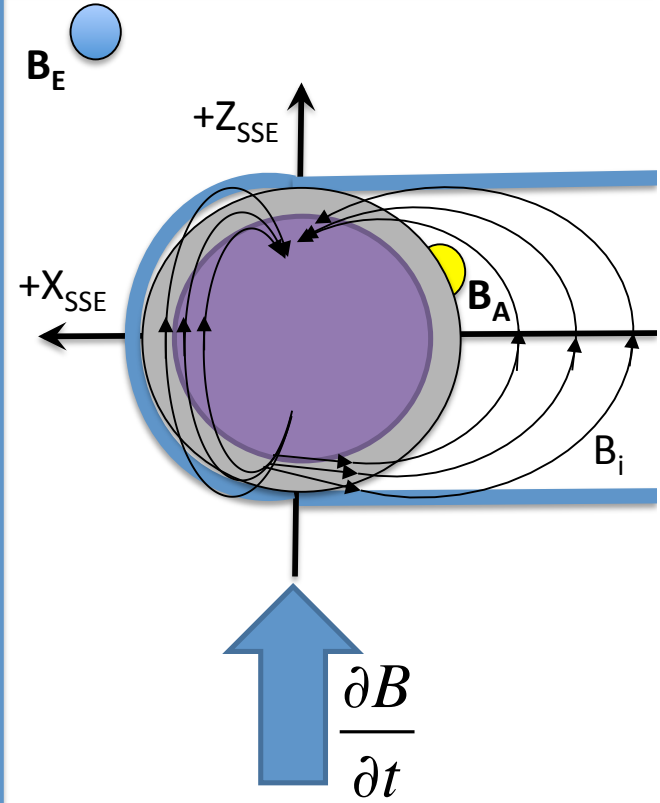

The Apollo Picture

Fuqua Haviland et al., 2019



# Time Domain EM (TDEM) Sounding Vacuum Model

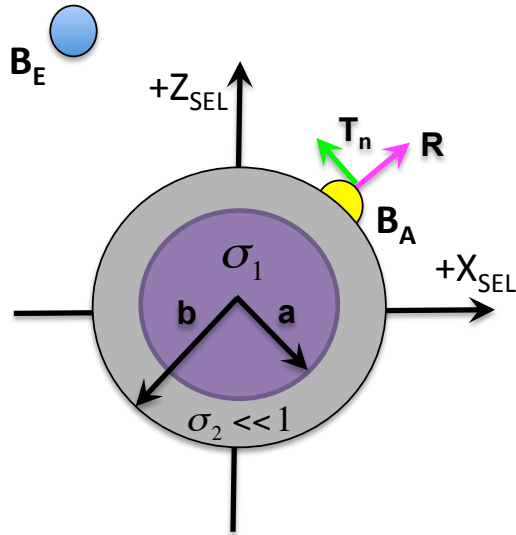

$$B_{A,R}(t) \propto -\left(\frac{a}{b}\right)^3 \Delta B_{E,R} F(t)$$

$$B_{A,T}(t) \propto \left(\frac{a}{b}\right)^3 \Delta B_{E,T} F(t)$$

$$F(t) \propto \exp\left(-t / \sigma_a a^2\right)$$

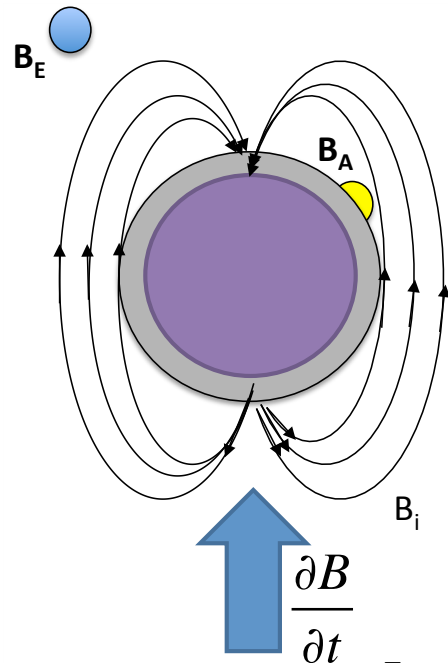

Dyal & Parkin, 1971



# TDEM Sounding Vacuum Model

Dyal & Parkin, 1971:

$$B_{Ax}(t) = -3 \left( \frac{R_c}{R_M} \right)^3 \Delta B_{Ex} F(t) + B_{Exf}$$

$$B_{Ay}(t) = \frac{3}{2} \left( \frac{R_c}{R_M} \right)^3 \Delta B_{Ey} F(t) + B_{Eyf}$$

$$B_{Az}(t) = \frac{3}{2} \left( \frac{R_c}{R_M} \right)^3 \Delta B_{Ez} F(t) + B_{Ezf}$$

$$F(t) = 2\pi^{-1/2} x \sum_{s=1}^{\infty} \frac{1}{s^2} \exp\left(-s^2 \pi^2 t / \sigma_c \mu_o R^2\right)$$

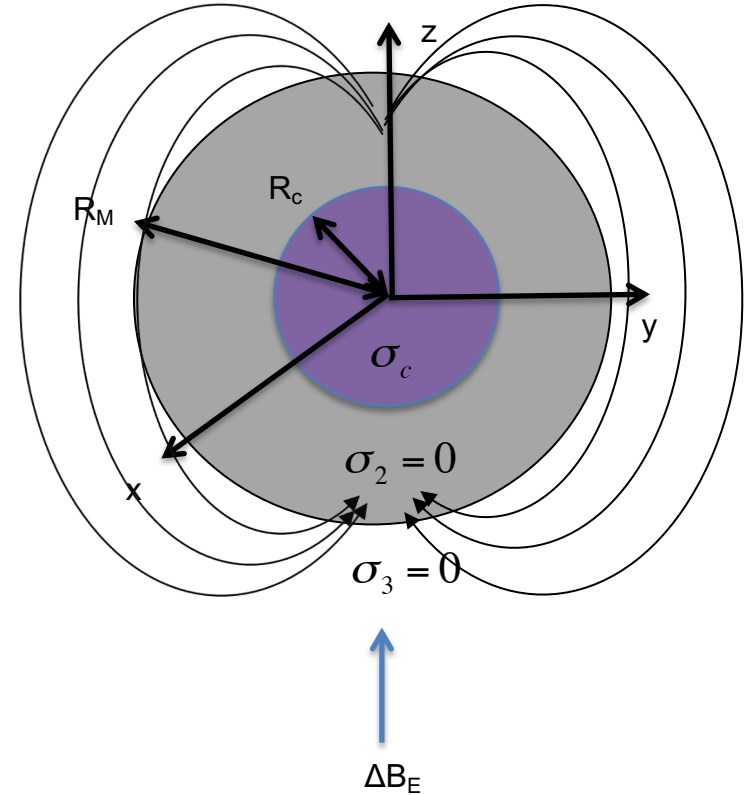

---

$$A_0 = A_{1=core}$$

$$\mu_o \frac{\partial}{\partial r} (r A_0) = \mu_o \frac{\partial}{\partial r} (r A_{1=core})$$

$$B_{\perp 0} = B_{\perp 1}$$

**B<sub>A</sub>** = Total Field, measured near surface (Wake Probe)

**B<sub>E</sub>** = External Driving Field (Reference Probe)

# TDEM Sounding Theory

SWITCH ON

SWITCH OFF

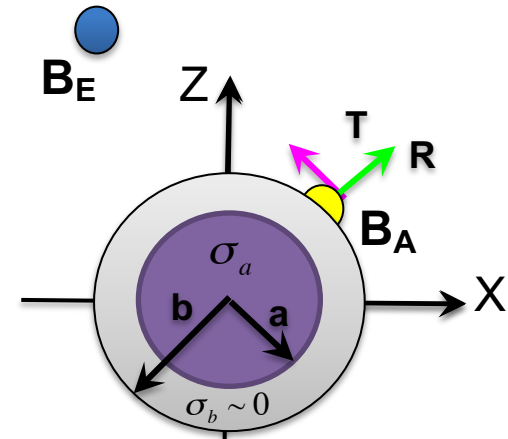
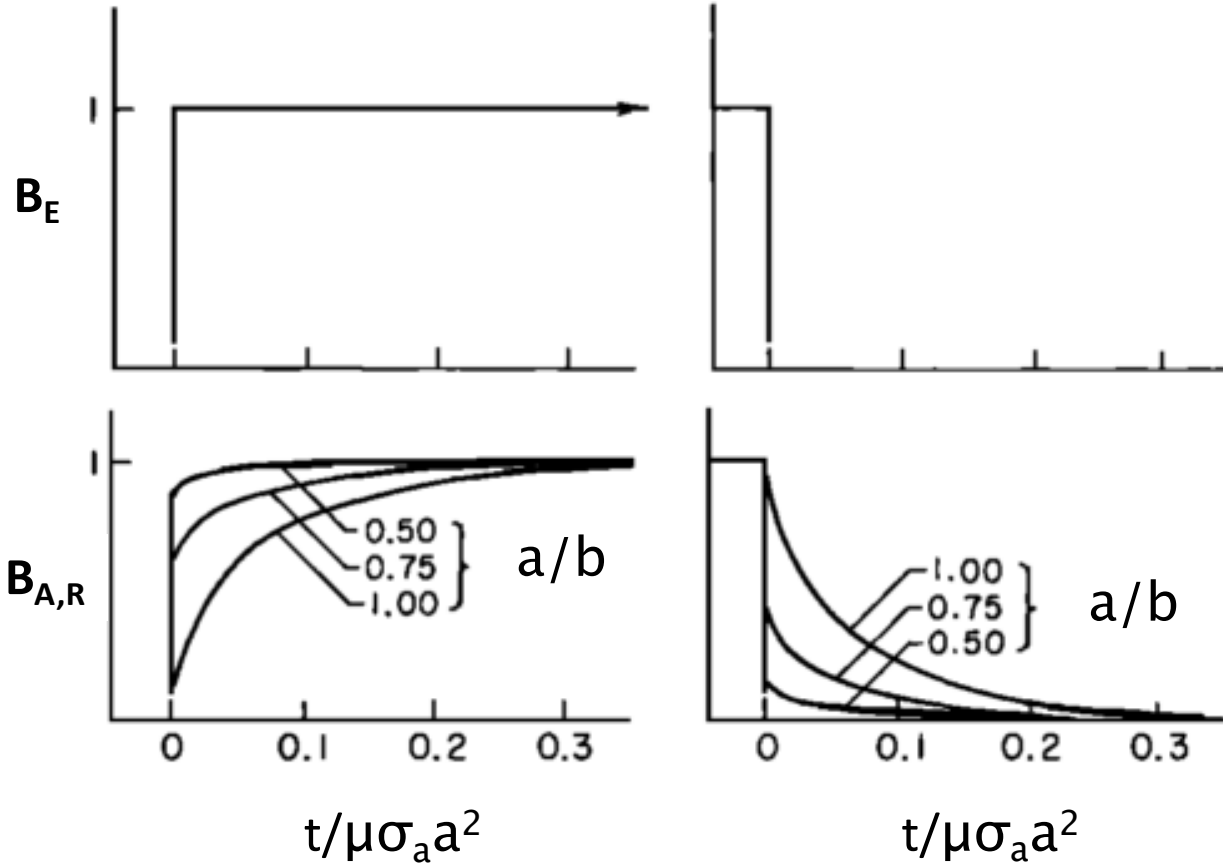

Fuqua Haviland et al., 2019

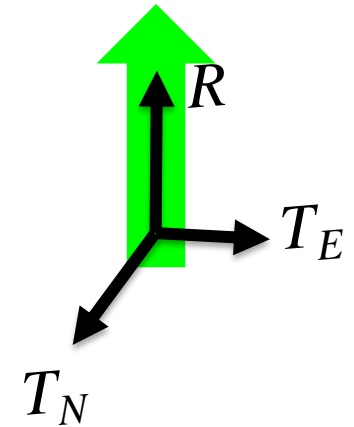

Dyal & Parkin 1971  
Sonett, 1982

# TDEM Sounding Theory

SWITCH ON

SWITCH OFF

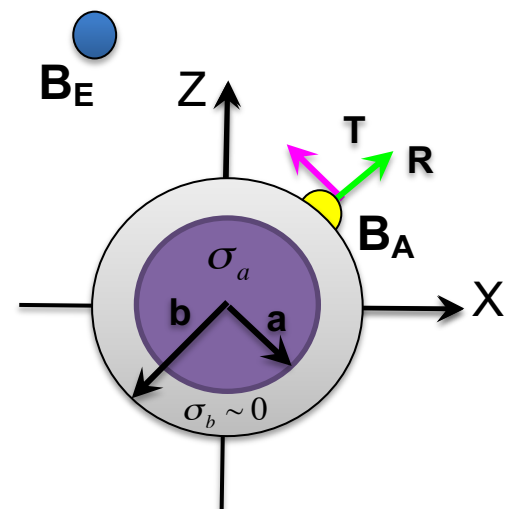
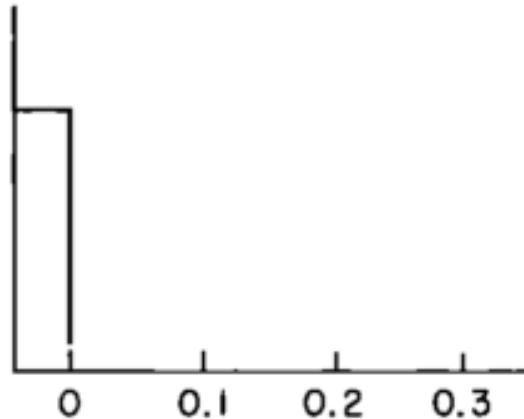
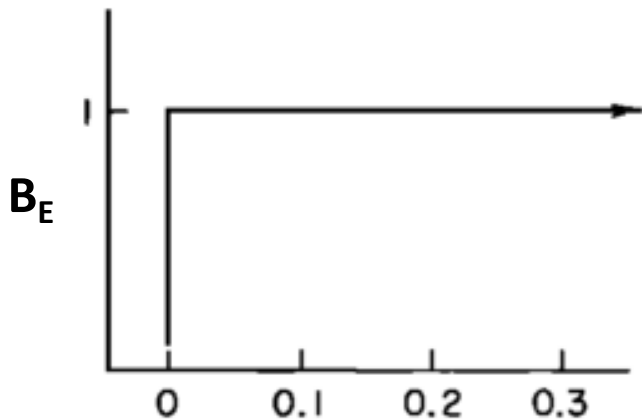

Fuqua Haviland et al., 2019

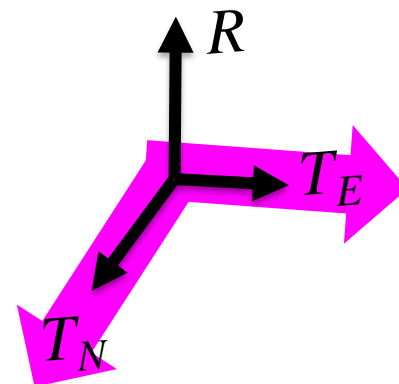
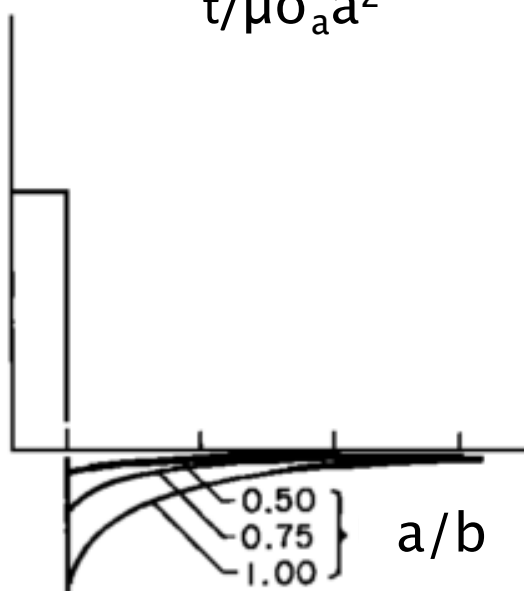
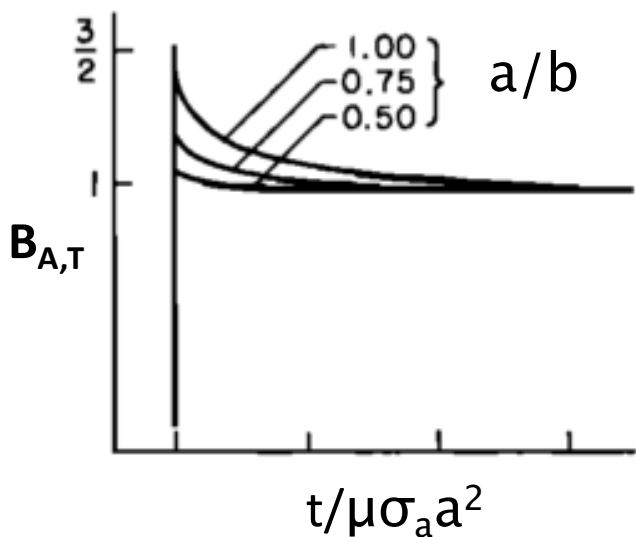

Dyal & Parkin 1971  
Sonett, 1982

# COMSOL Finite Element Method (FEM) Implementation

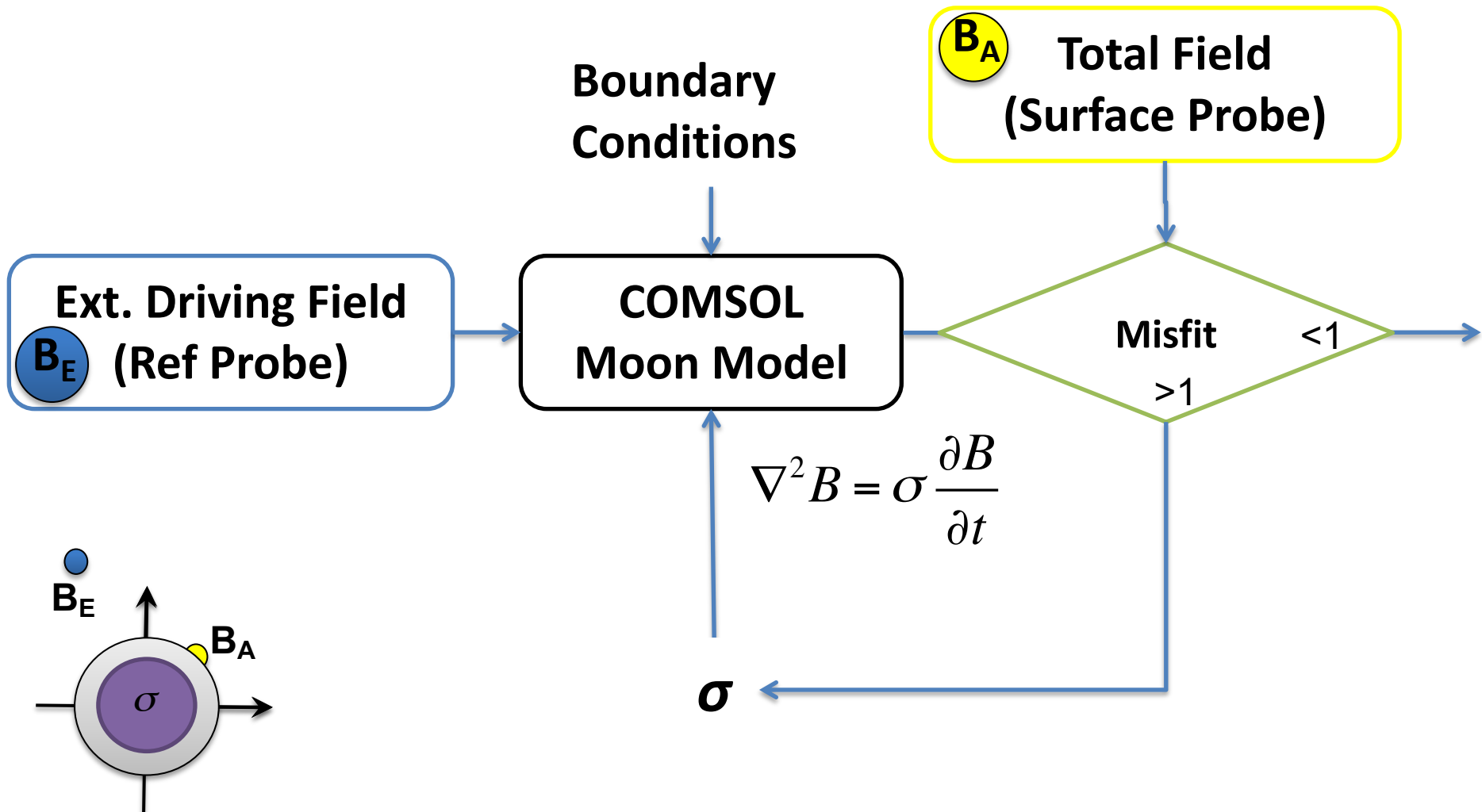

# COMSOL FEM Forward Model

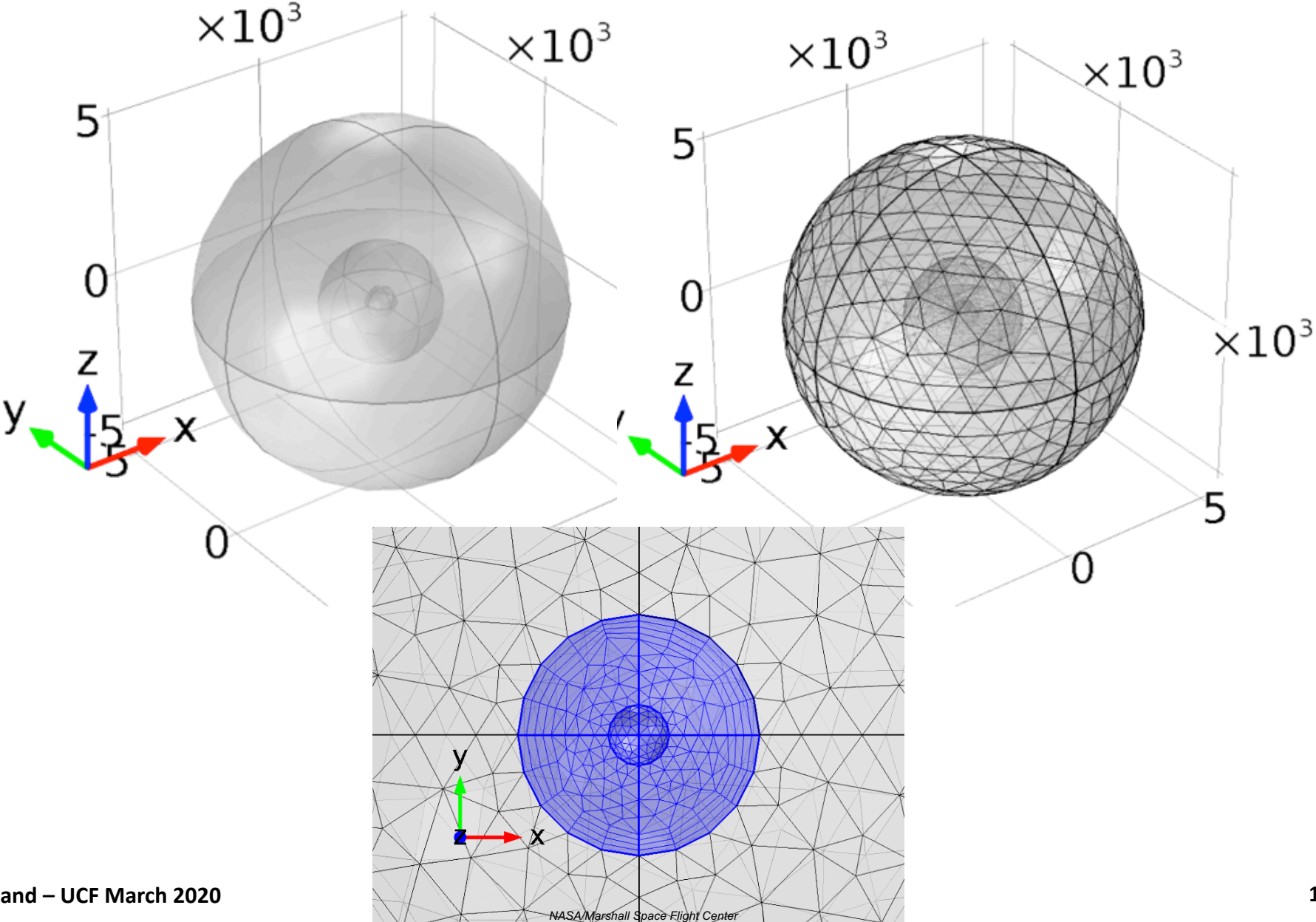

# 3D Electrical Conductivity Models

$$\sigma_{\text{vacuum}} = 1e-13 \text{ S/m}$$

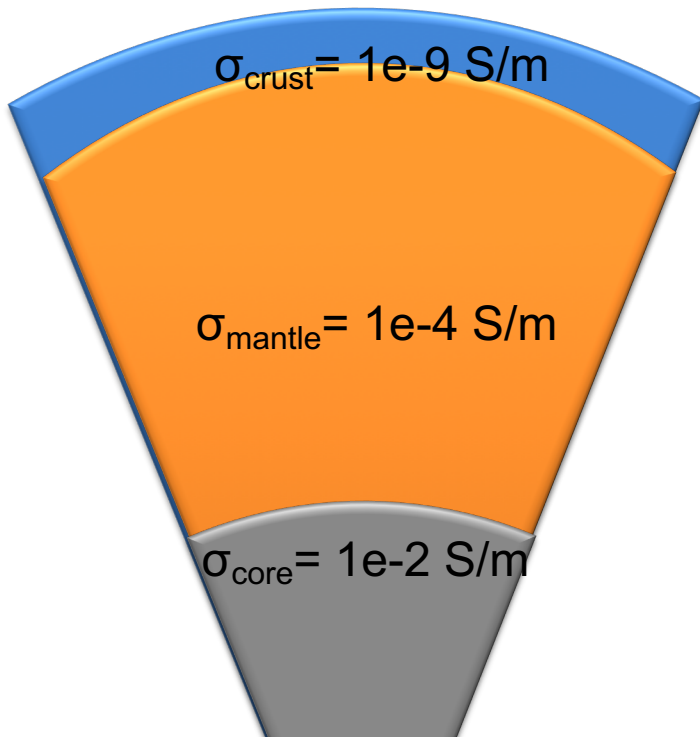

$$\sigma_{\text{vacuum}} = 1e-13 \text{ S/m}$$

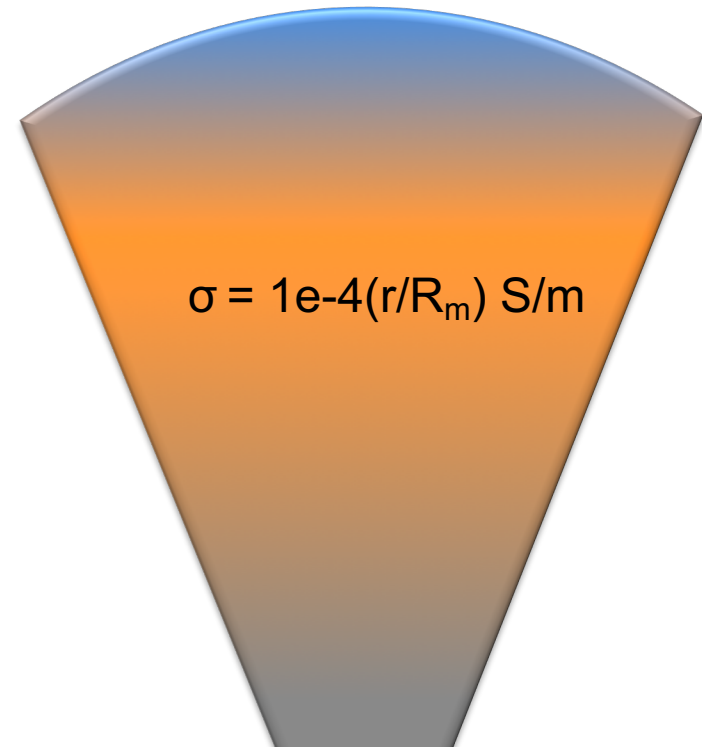

***FEM enables three-dimensional electrical conductivity profiles.***

**Model 1: 3 Layer Model**

**Model 2: Radial Conductivity Profile (w/&w/o crust)**



# Apollo Event

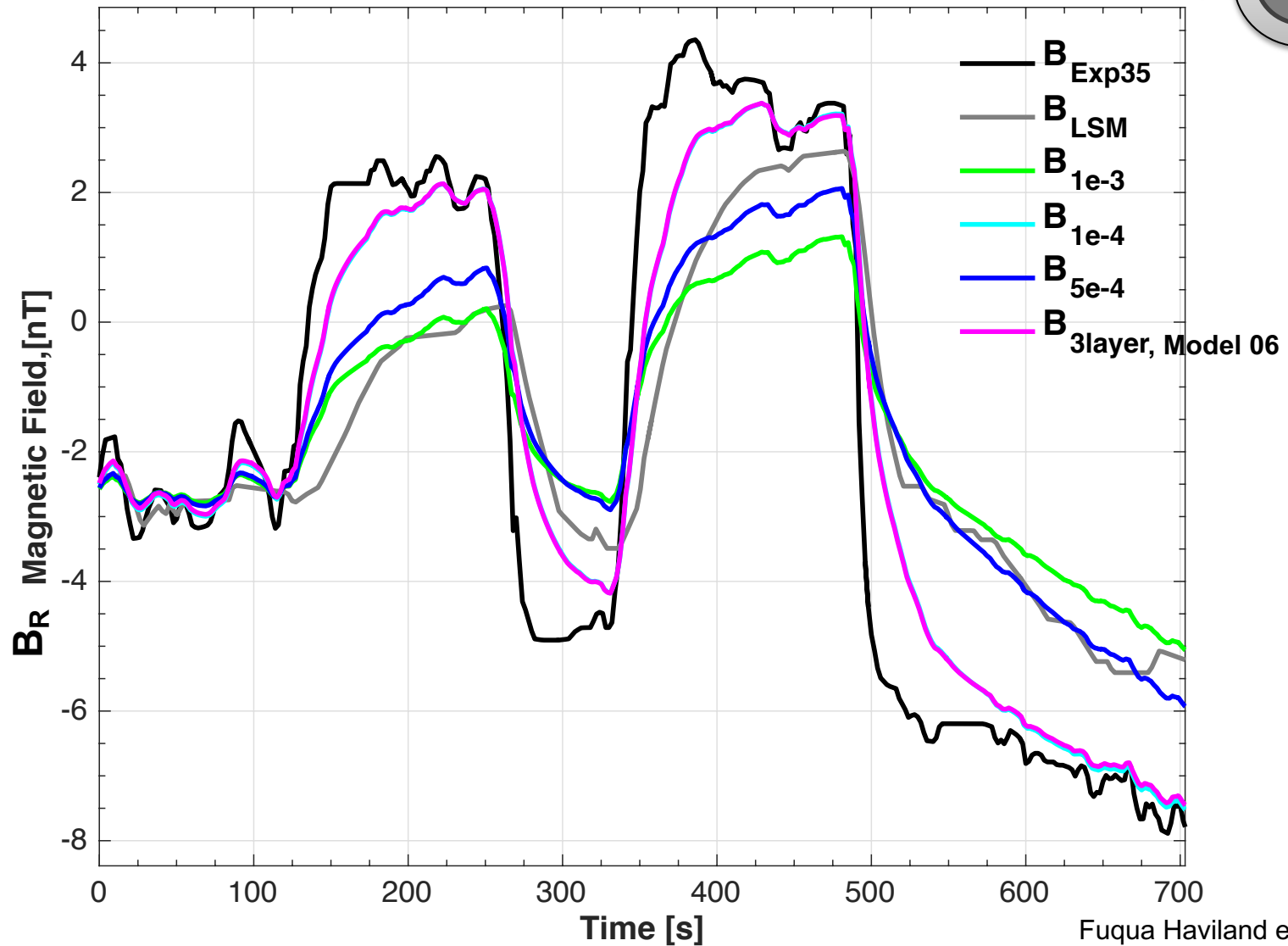
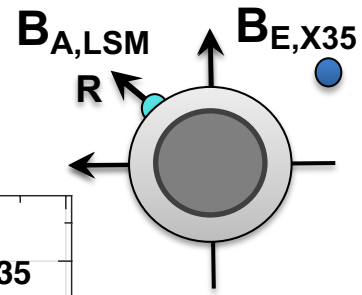

Fuqua Haviland et al., 2019  
After Dyal et al. [1971] figure 10

# Apollo Event

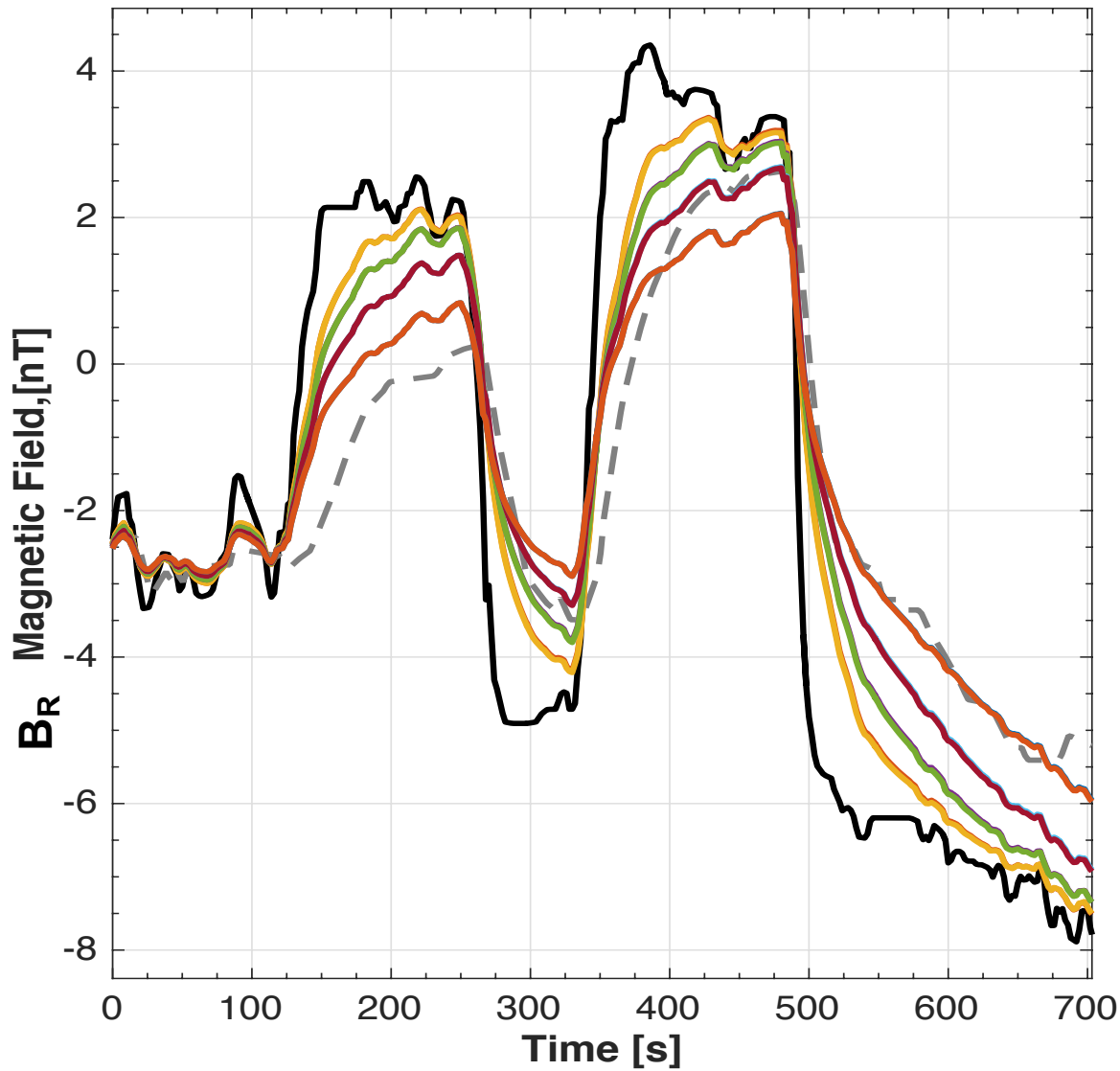

- $B_{Exp35}$
- - -  $B_{LSM}$
- $B_{06:m.1.0e-4,c.1e-2}$
- $B_{07:m.1.0e-4,c.1e+3}$
- $B_{08:m.1.5e-4,c.1e-2}$
- $B_{09:m.1.5e-4,c.1e+3}$
- $B_{10:m.2.5e-4,c.1e-2}$
- $B_{11:m.2.5e-4,c.1e+3}$
- $B_{12:m.5.0e-4,c.1e-2}$
- $B_{13:m.5.0e-4,c.1e+3}$

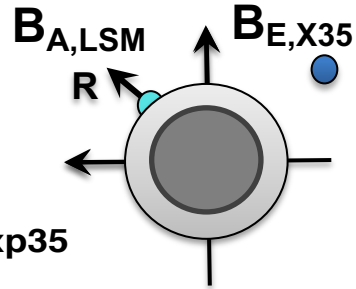

Fuqua Haviland et al., 2019  
After Dyal et al. [1971] figure 10

# Apollo Event

Fuqua Haviland et al., 2019

Digitized Apollo Data: North

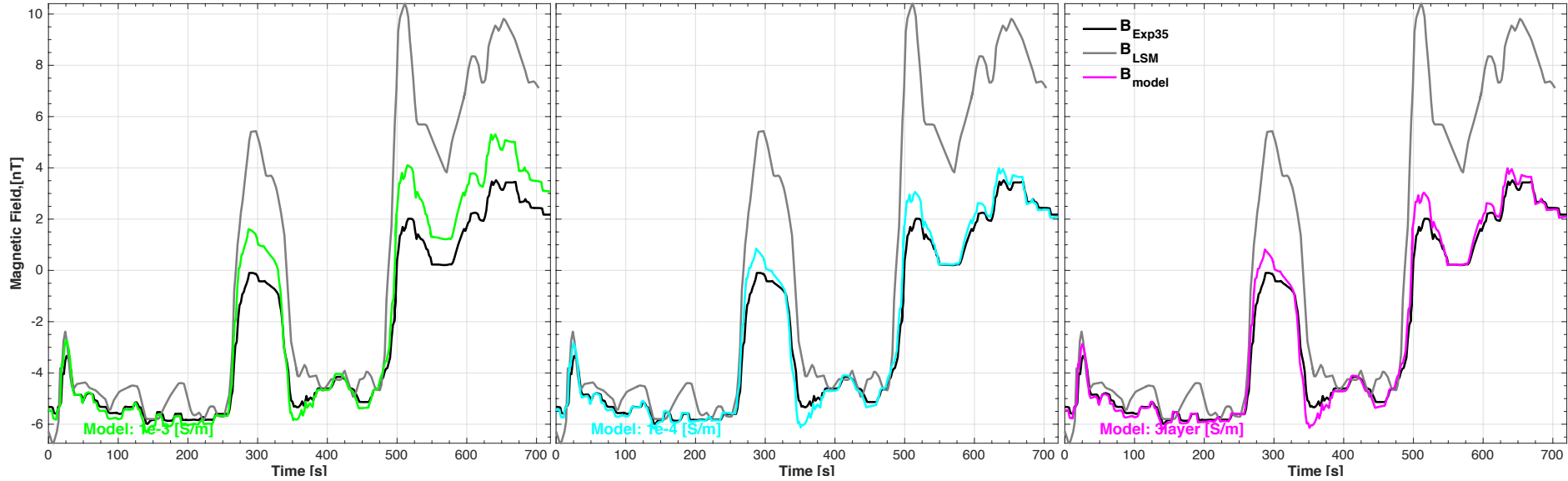

Digitized Apollo Data: East

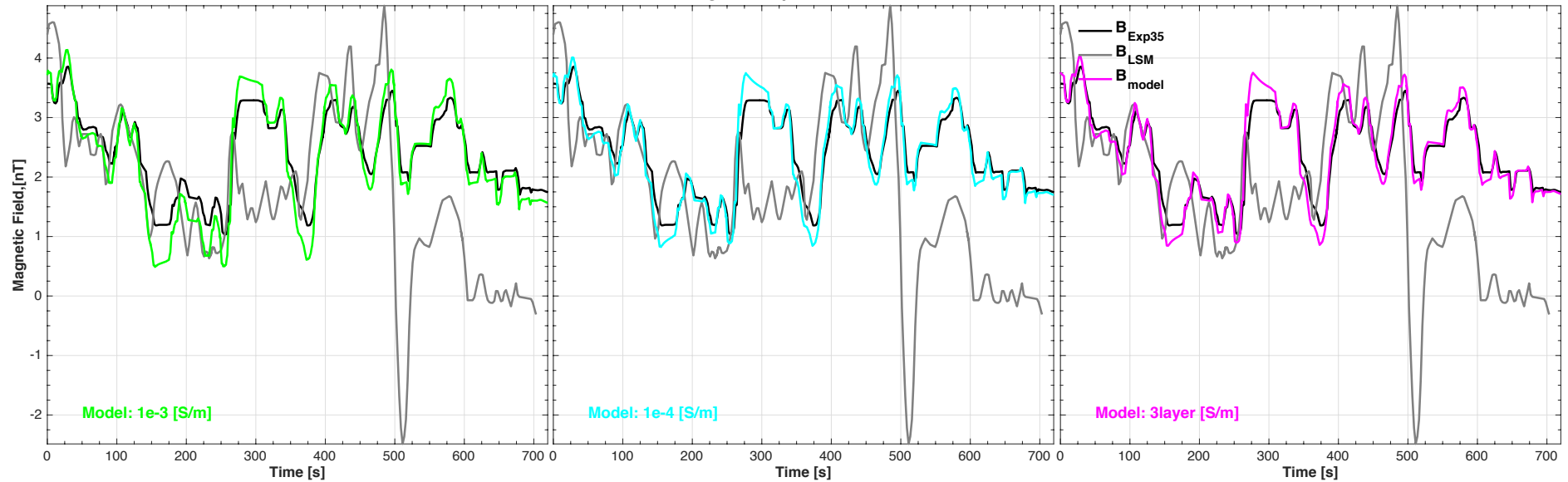

# Challenges for TDEM

- Cannot fully capture all features of the Apollo surface observation with simple forward model.
  - Inversion?
- Does not consistently observe both the radial damping and tangential overshoot predicted by vacuum TDEM analytic theory.

***How do induced magnetic fields interact with ambient plasma? Is wake confinement accurate? When can the vacuum approximation be applied?***

**(a) Plasma hybrid model with static magnetic dipole study**

**(b) Transient Plasma induction model**

# Wake Current Systems

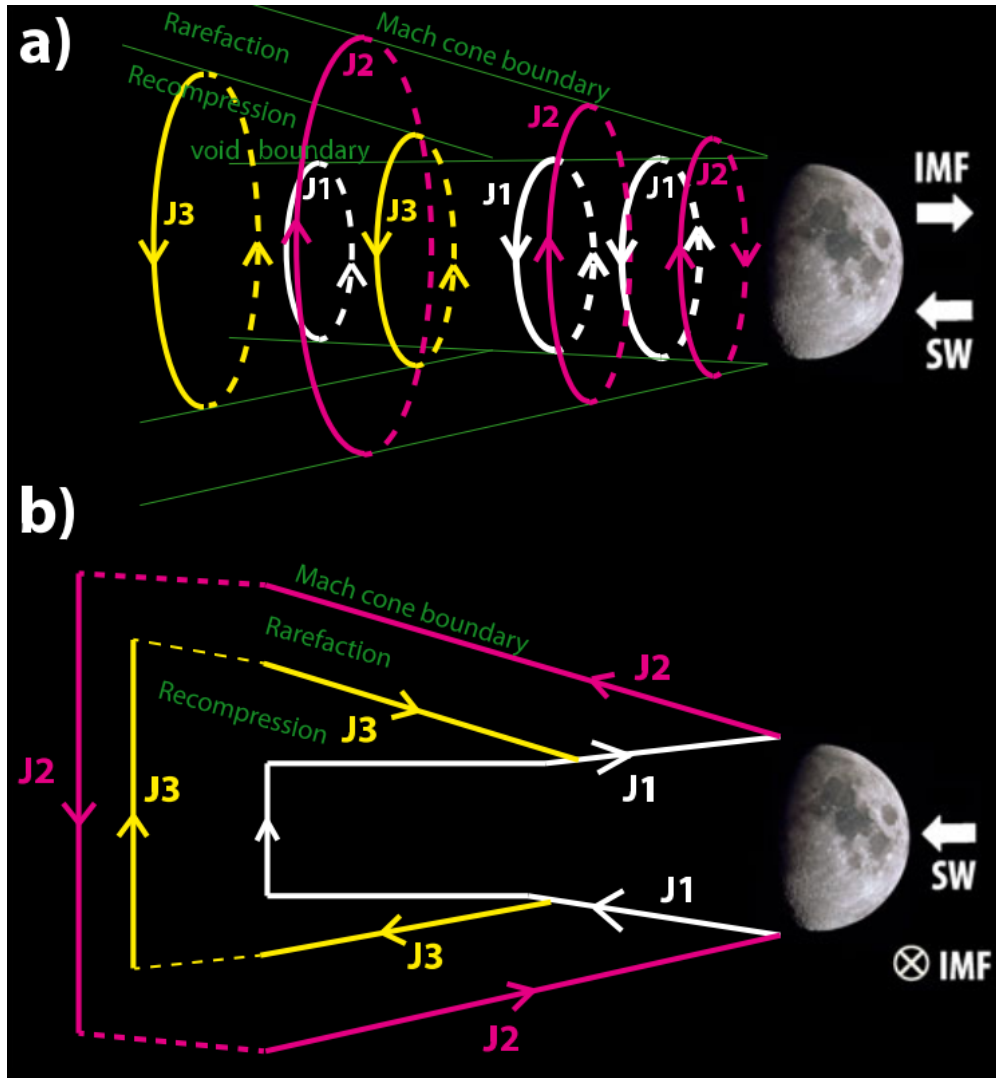

what we know:

- wake forms on nightside due to dayside absorption and vacuum cavity
- wake current systems (incl. structure, extent) organize according to solar wind characteristics

$$\mathbf{v}_{sw}, \mathbf{B}_{IMF}$$

$$n_e, n_i$$

$$T_e, T_i$$

$\sigma(r), t$  This study

Fatemi et al., [2014]  
Holmstrom et al., [2012]



# Static Plasma Hybrid Kinetic Model

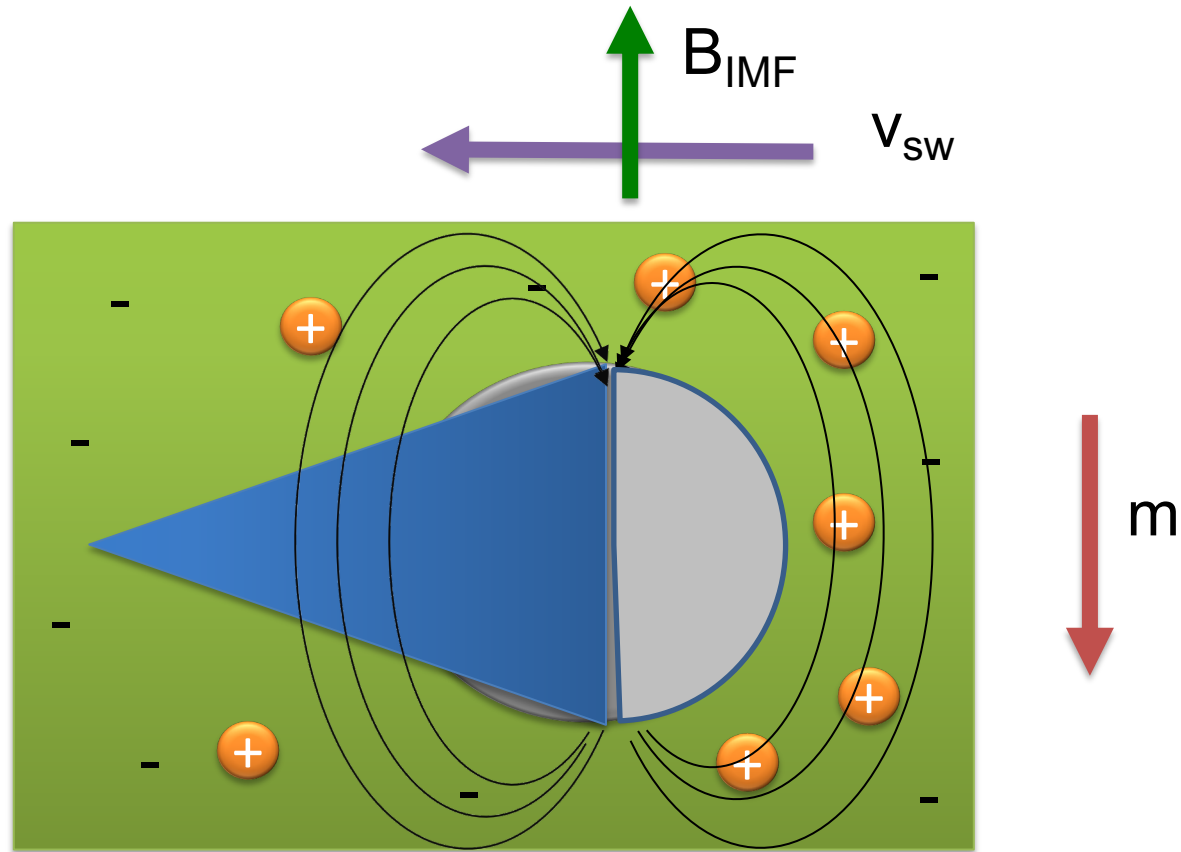

# Static Hybrid Model Results

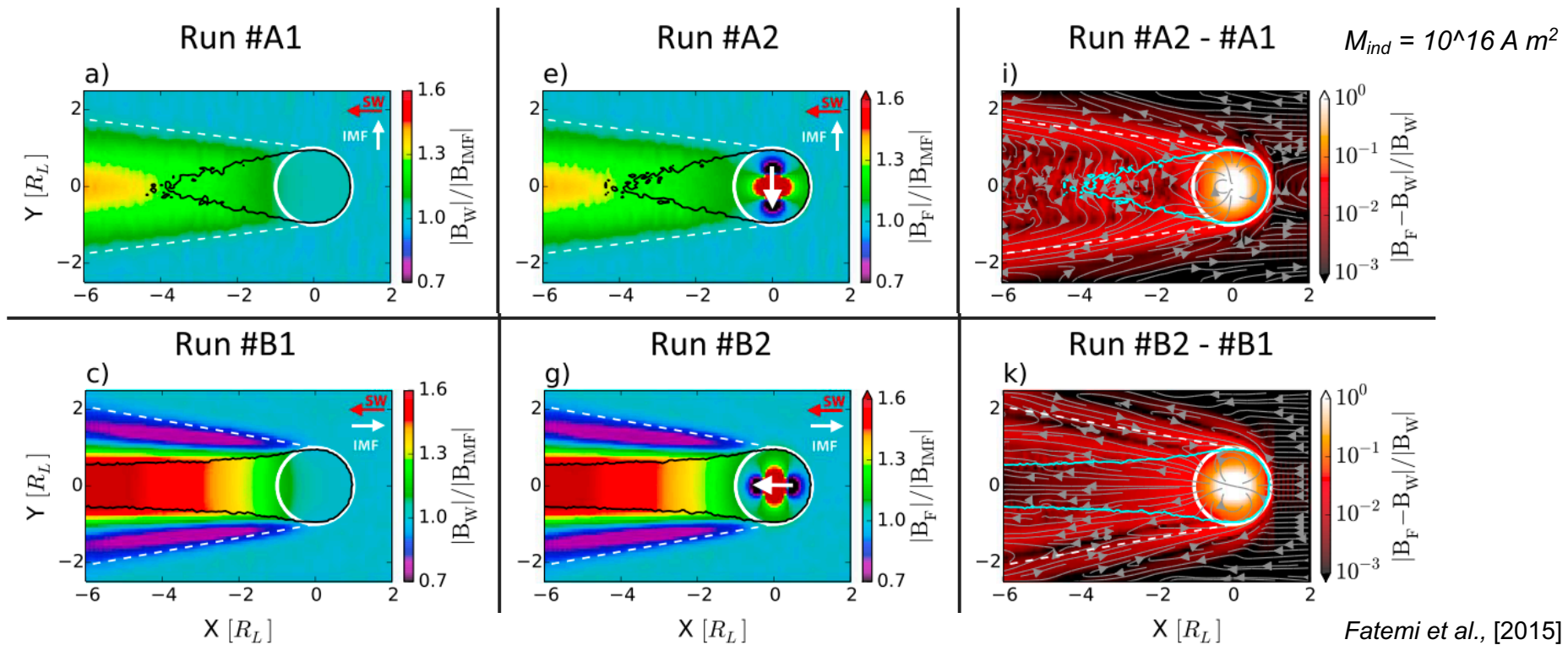

*Dayside confinement, as predicted. Nightside fields are not confined within wake cavity. Strong induced field signatures in the deep wake near surface, especially with large IMF changes.*

# Transient Plasma Hybrid Kinetic Induction Model

General Case,  
Perpendicular

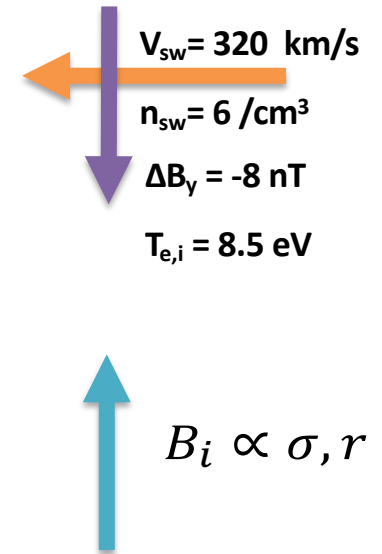
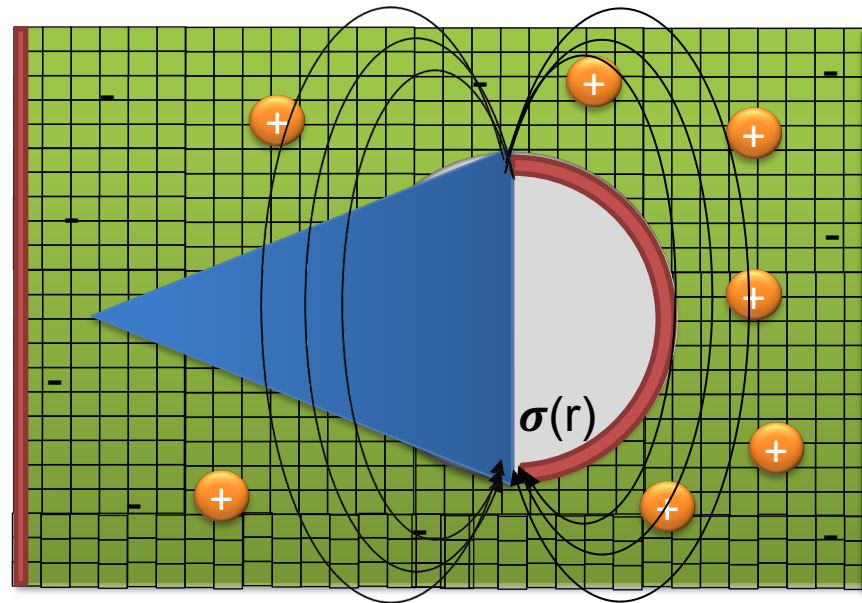

- Cell size: 50 km ( $\sim 0.028 R_L$ )
- 16 macroparticles (only protons) per cell
- $t_{step} = 0.001 \text{ s}$
- $0 < t < \sim 300 \text{ s}$ ,  $t=24 \text{ s}$  IMF discontinuity
- $\sigma_1 = 1.0 \text{ e} - 8, 1.0 \text{ e} - 4, 1.0 \text{ e} - 3 \text{ [S/m]}$

- Conducting radius ( $r_1$ ) = 1,600 km ( $\sim 0.91 R_L$ , or  $\sim 32$  cells),  $\sim M_{ind} = 1.64 \text{ e} 17 \text{ A m}^2$  (Fatemi et al., 2015; Saur et al., 2010).
- Resistive crust ( $1\text{e}-8 \text{ S/m}$ ) radius = 150 km ( $\sim 3$  cells crust)
- Model captures inductive and plasma response self-consistently
- SSE Coordinate System: Selenographic Solar Ecliptic ( $+X_{SSE}$  points towards the sun)

# Results: Single Time Step

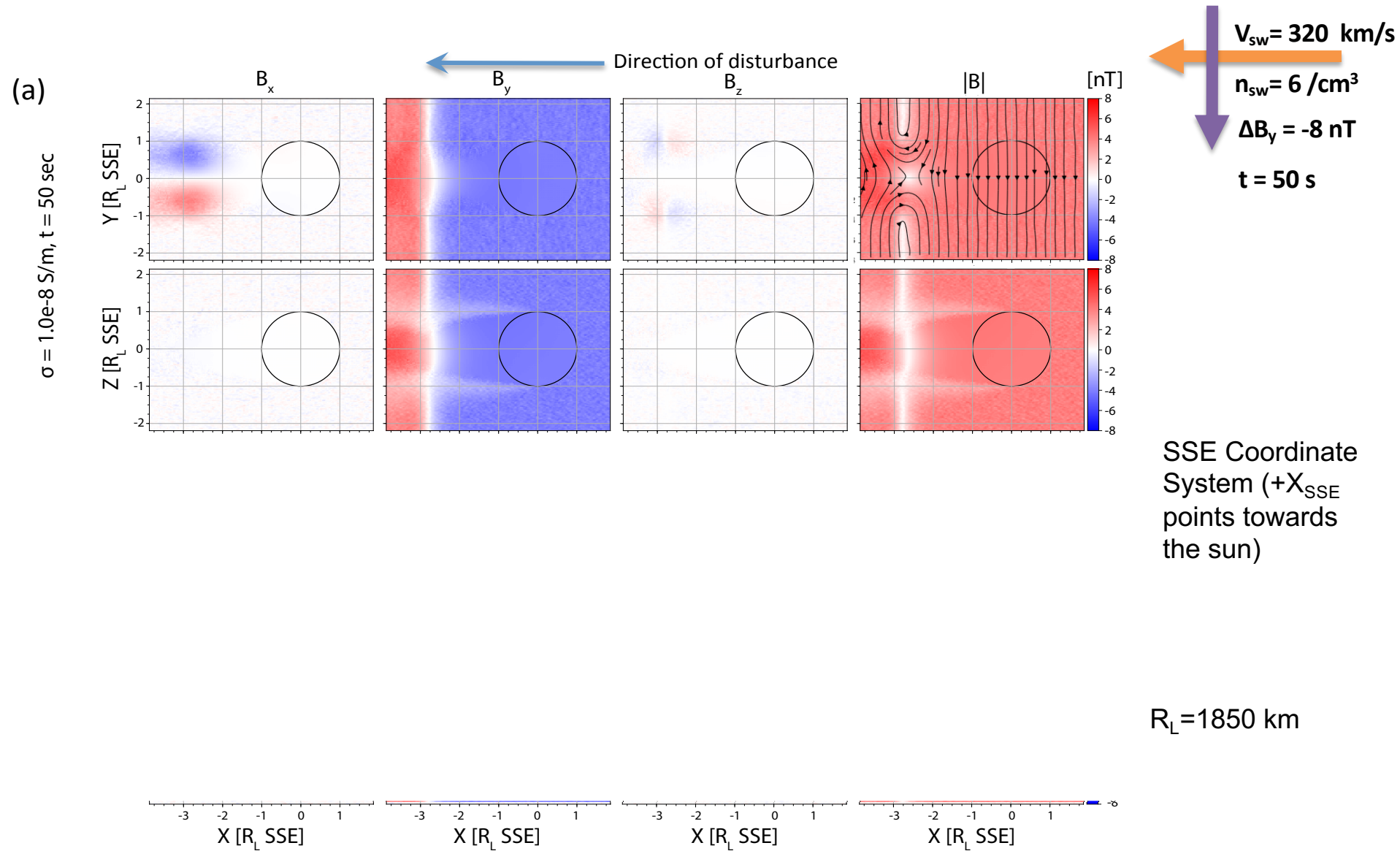

# Results: Single Time Step (con't)

(c)

Difference,  $t = 50$  sec

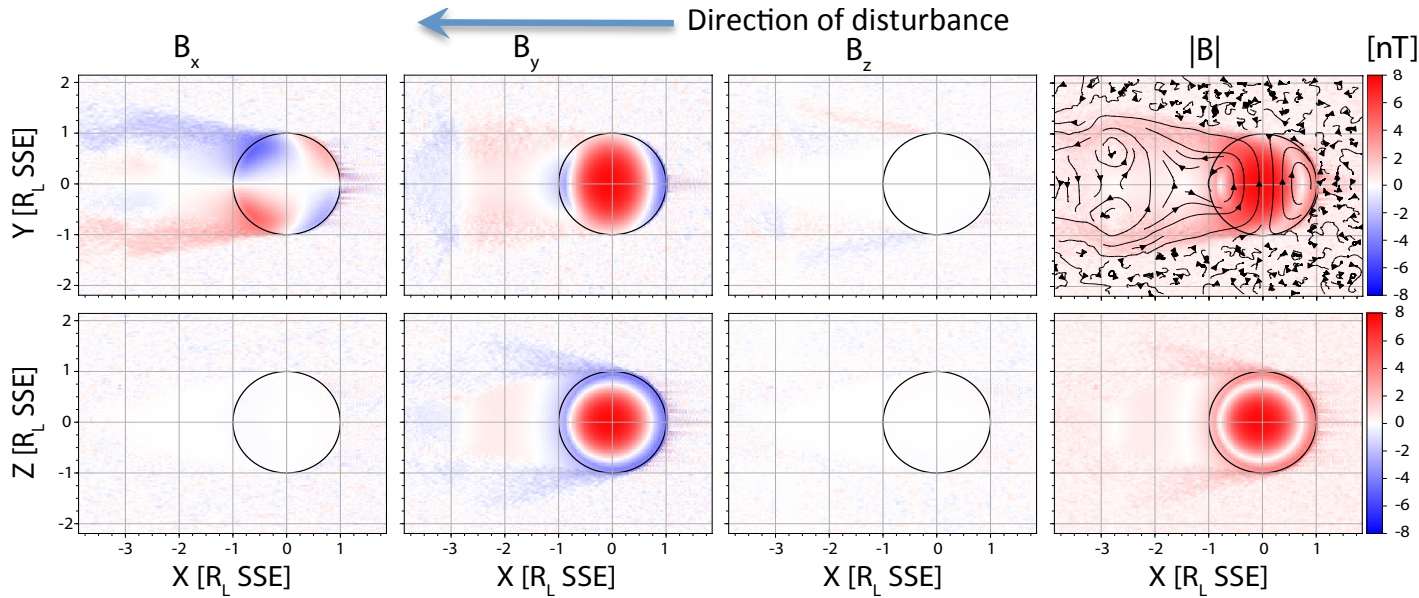

$$\text{Residual Difference} = \text{Conductive Case} - \text{Resistive Case} \quad (\text{Plasma Effects Only})$$

# Results: Time Dependence

$V_{sw} = 320 \text{ km/s}$   
 $n_{sw} = 6 \text{ /cm}^3$   
 $\Delta B_y = -8 \text{ nT}$

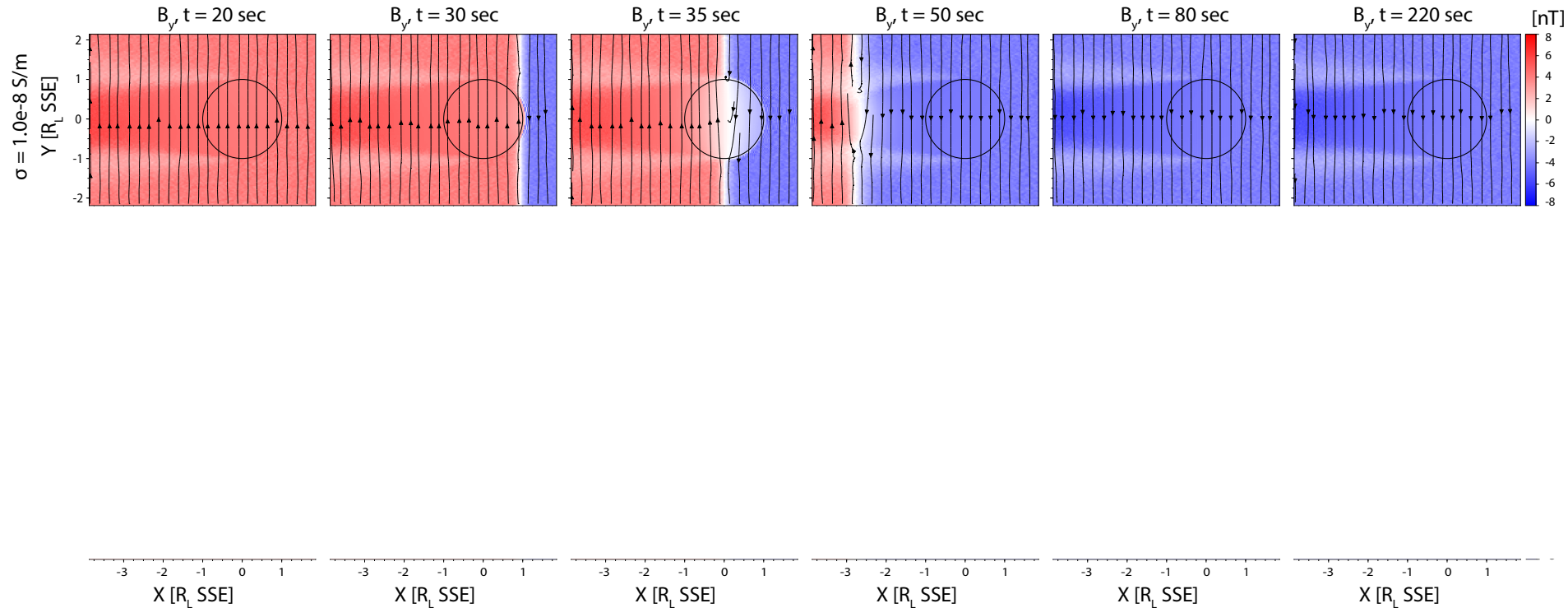

SSE Coordinate System (+ $X_{SSE}$  points towards the sun)

$R_L = 1850 \text{ km}$

# Results: Case Study 1 Time Series

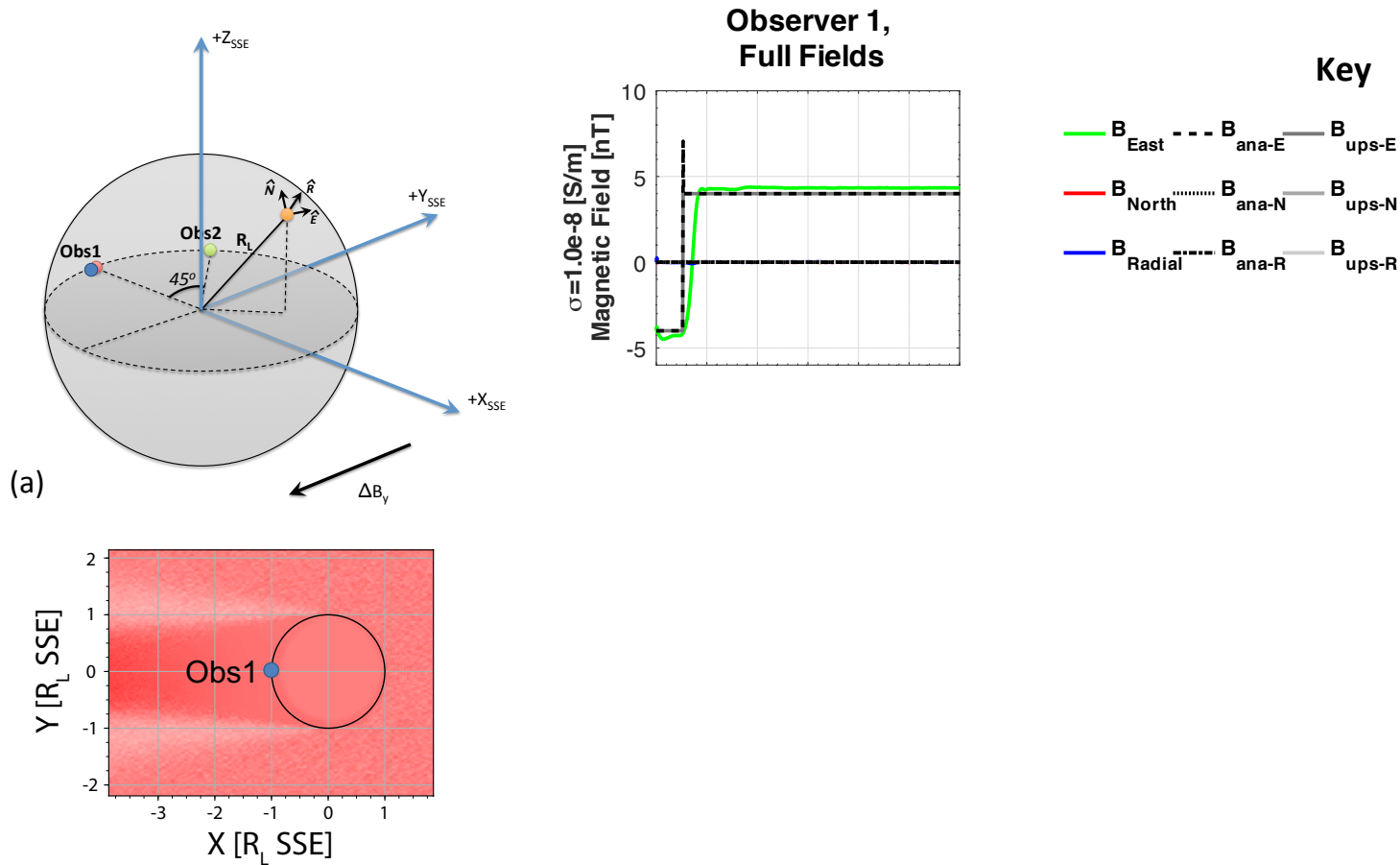



# Results: Case Study 2 Time Series

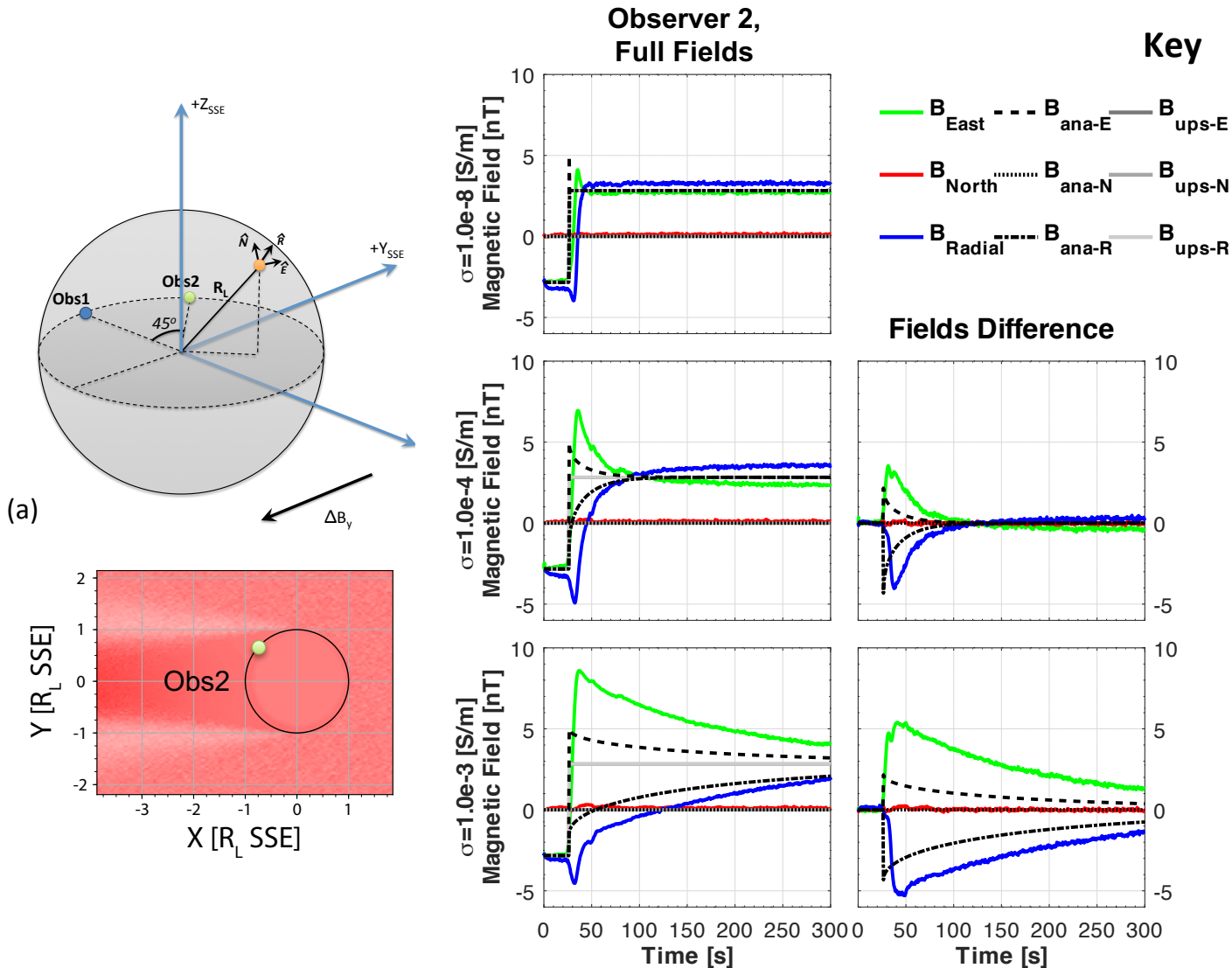



# Lunar Electromagnetic (EM) Sounding Transient Response Method

(a) TDEM Geometry

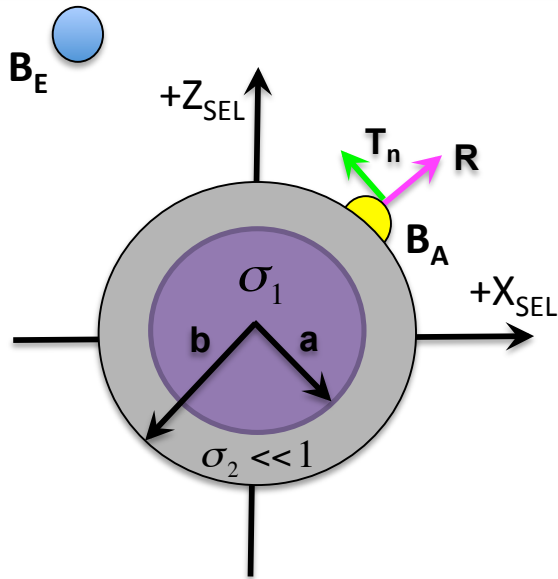

(b) Magnetotail Induction

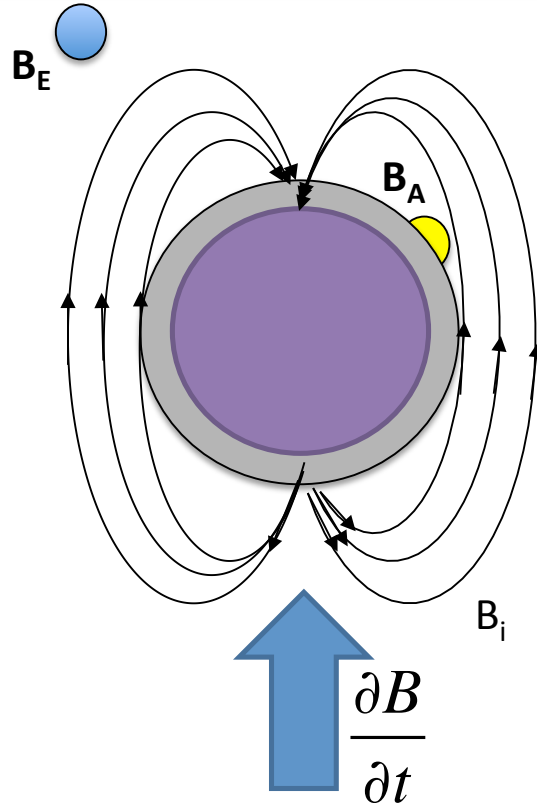

(c) Solar Wind Induction

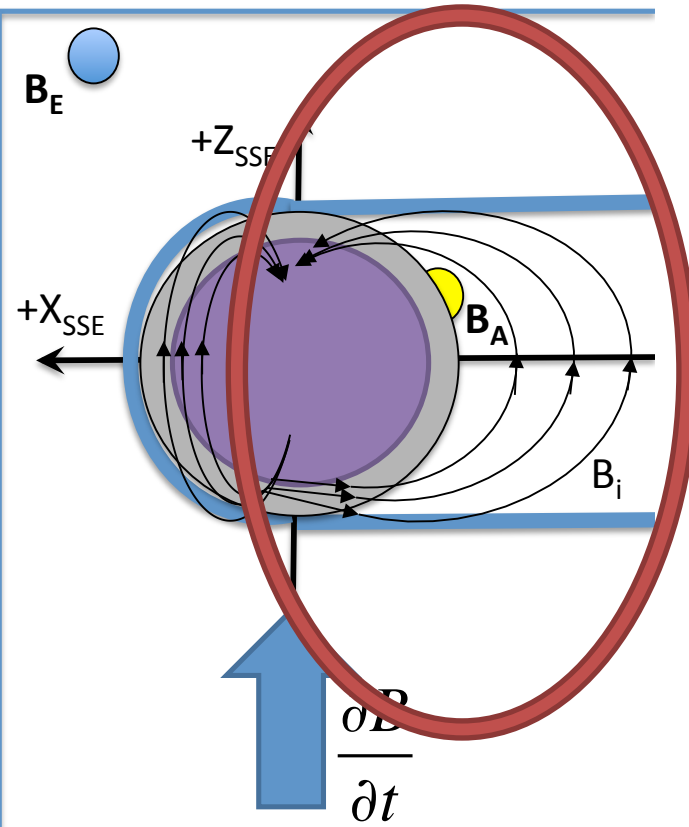

The Apollo Picture

Fuqua Haviland et al., 2019. ASR

# Electrical Conductivity Profile

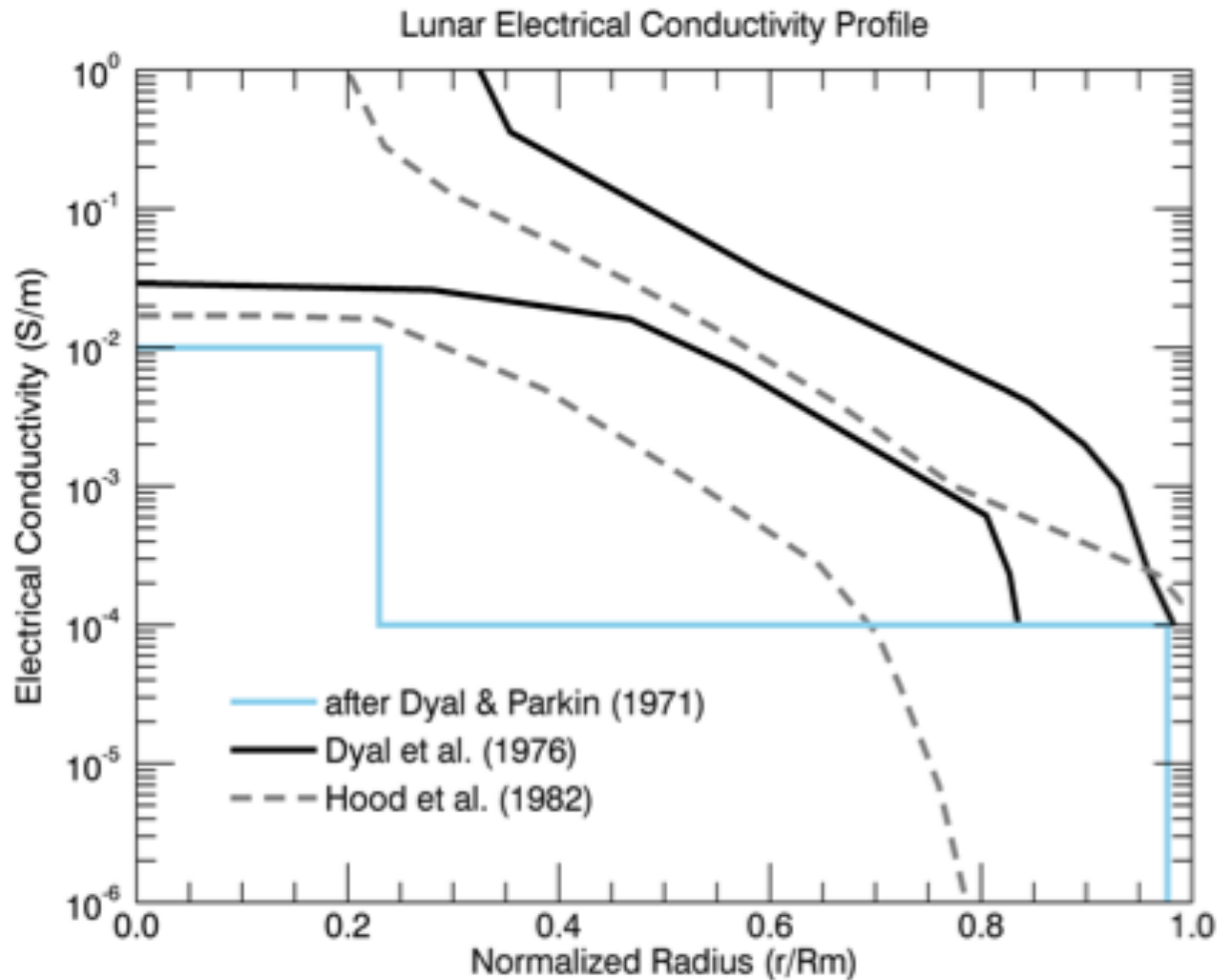

Fuqua Haviland et al., 2019. ASR.

# Elec. Conductivity Profile - Earth

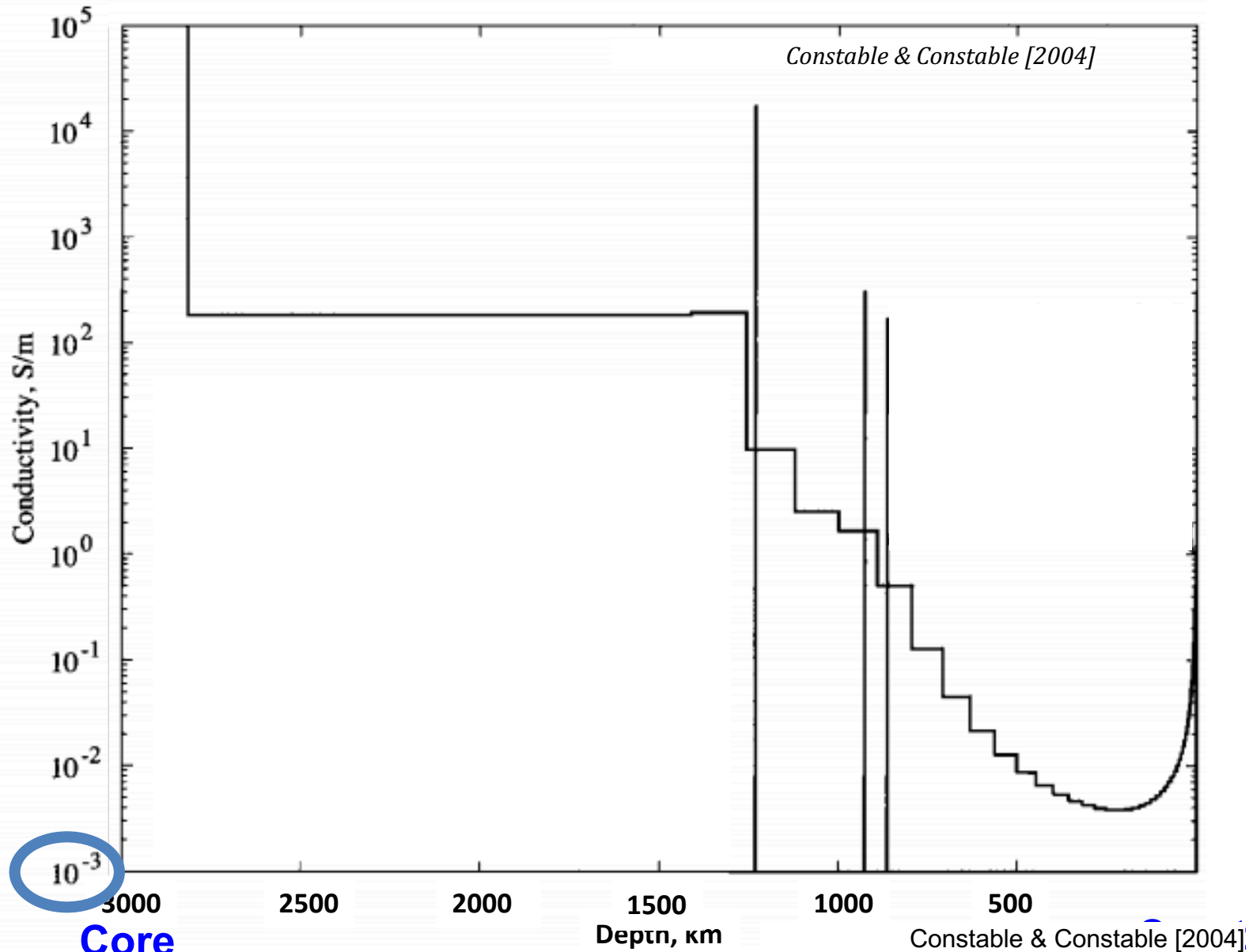

# Conclusion & Future Work

- Vacuum theory alone is not able to fully characterize nightside induced fields.
- Plasma hybrid model characterizes plasma currents which vary depending on solar wind conditions
- For the first time, we observe wake and induced field coupling. Redefining Apollo era assumption about wake field confining induced field within cavity.
- Additional work is needed to isolate induction with magnetometer observations (Apollo, Lunar Prospector, Kaguya, THEMIS-ARTEMIS).
- Future magnetometer observations at or near the surface of the Moon will improve electrical conductivity constraints with TDEM Sounding.

# Lunar Deep Space Gateway

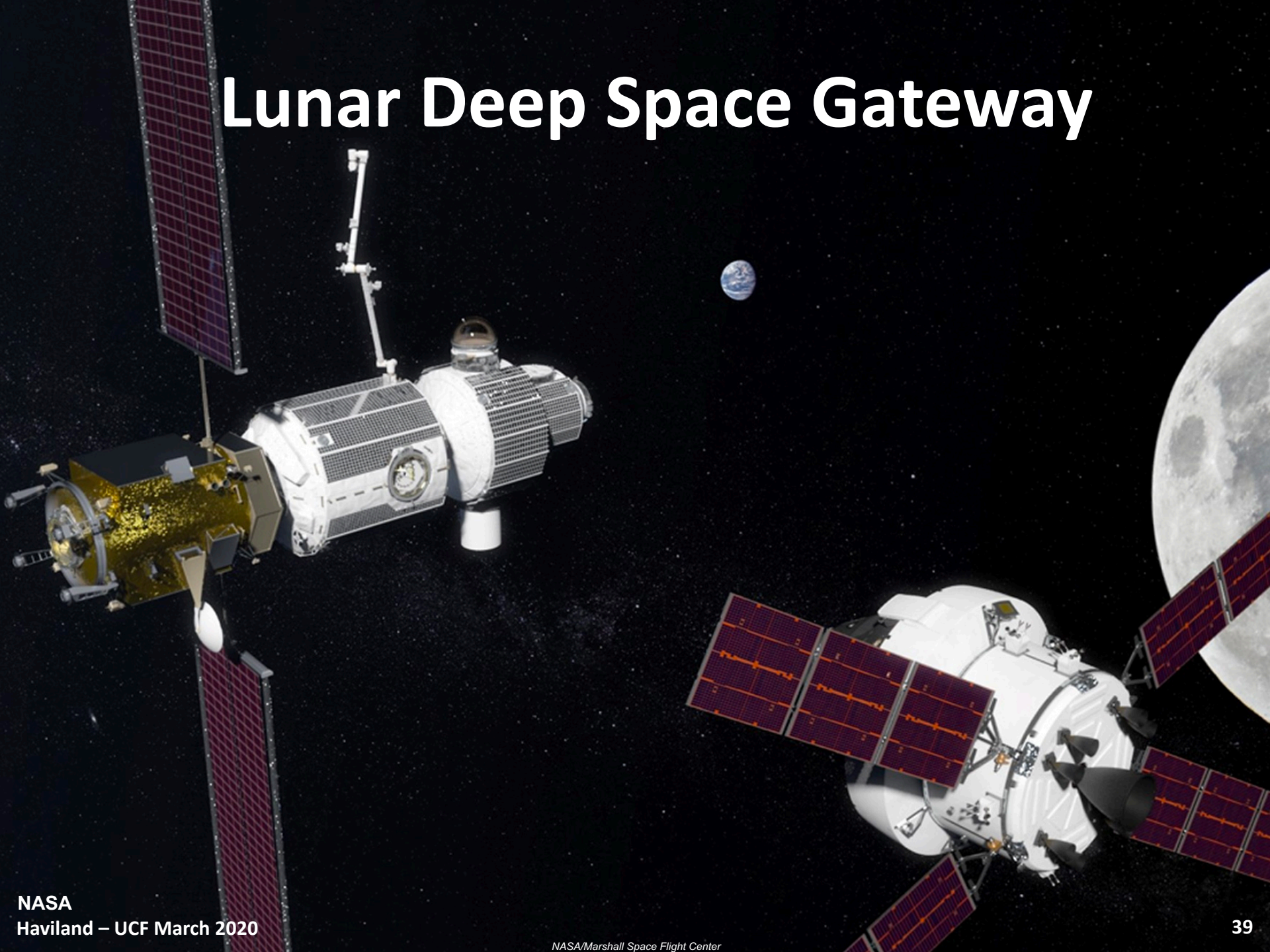



# Commercial Lunar Payload Services (CPLS)

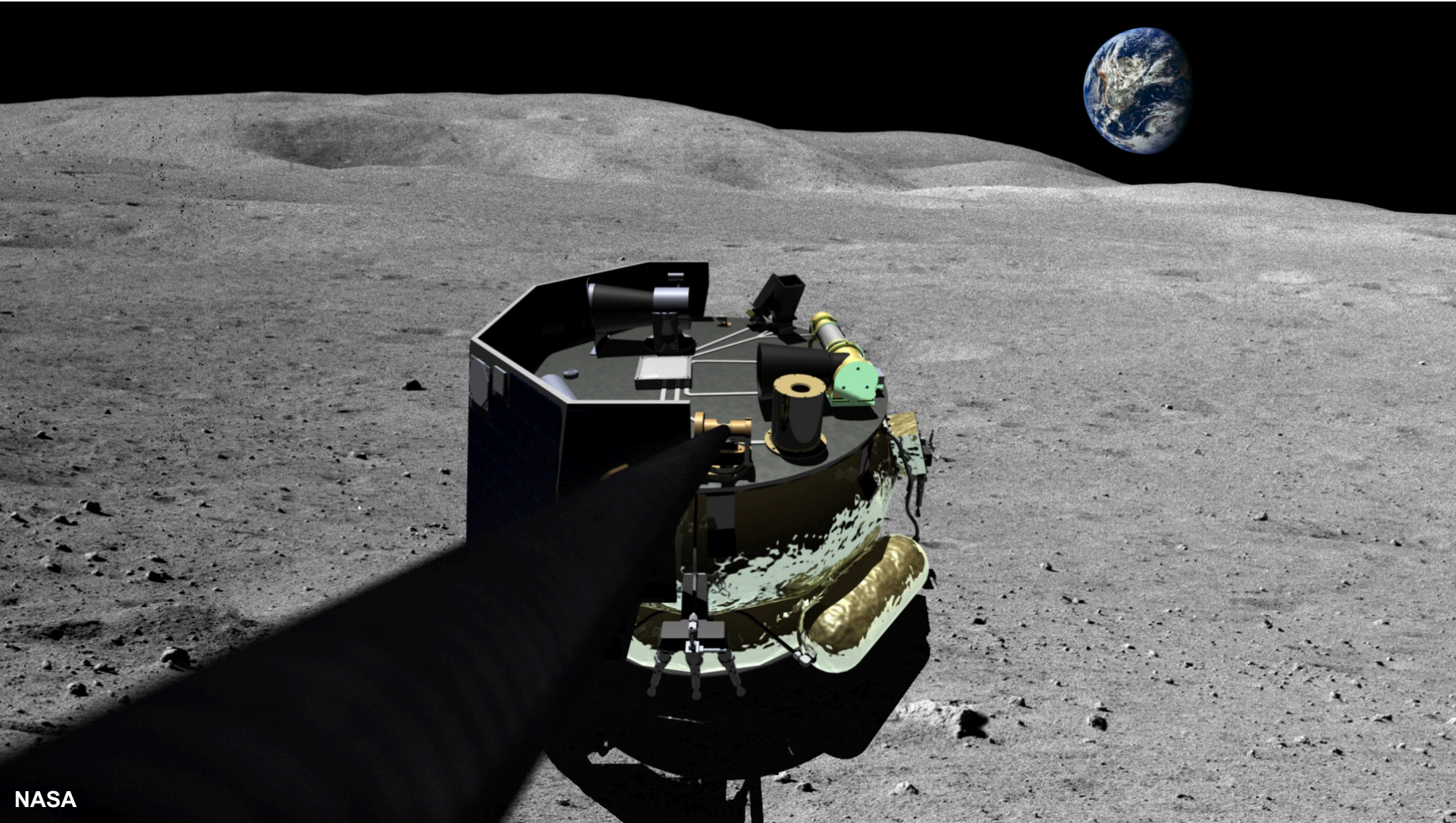

NASA

# Lunar Geophysical Network (LGN)

**Mission Objectives:** to improve the state of knowledge of the lunar interior in terms of composition, structure, temperature.



**Project Description:** The LGN will be composed of a network of ~4 stations with one farside station and communications orbiter. Each lander containing next generation instruments.

**Funding:** Preliminary Mission Concept Study  
NASA SMD Planetary Science Decadal Survey  
Update.

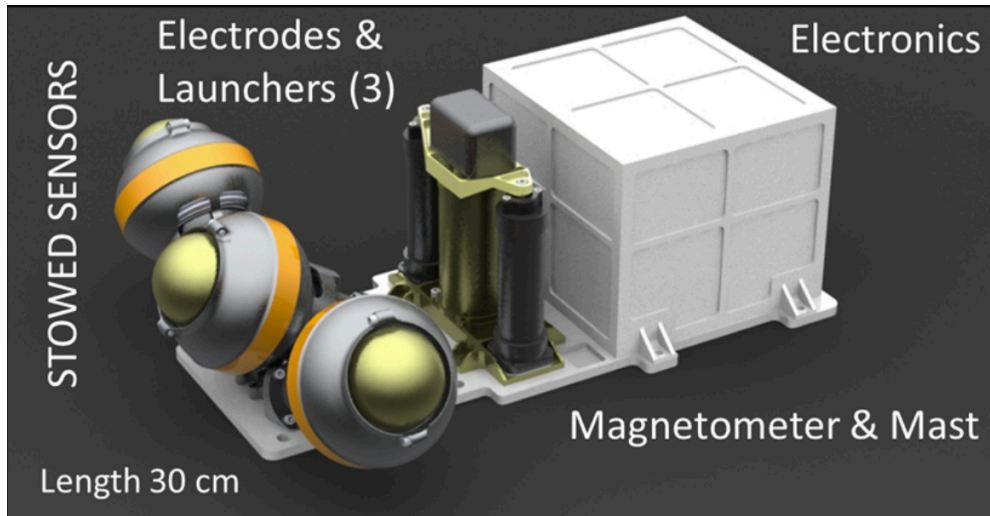

CPLUS Lunar Magnetic Sounder, Grimm et al. 2020

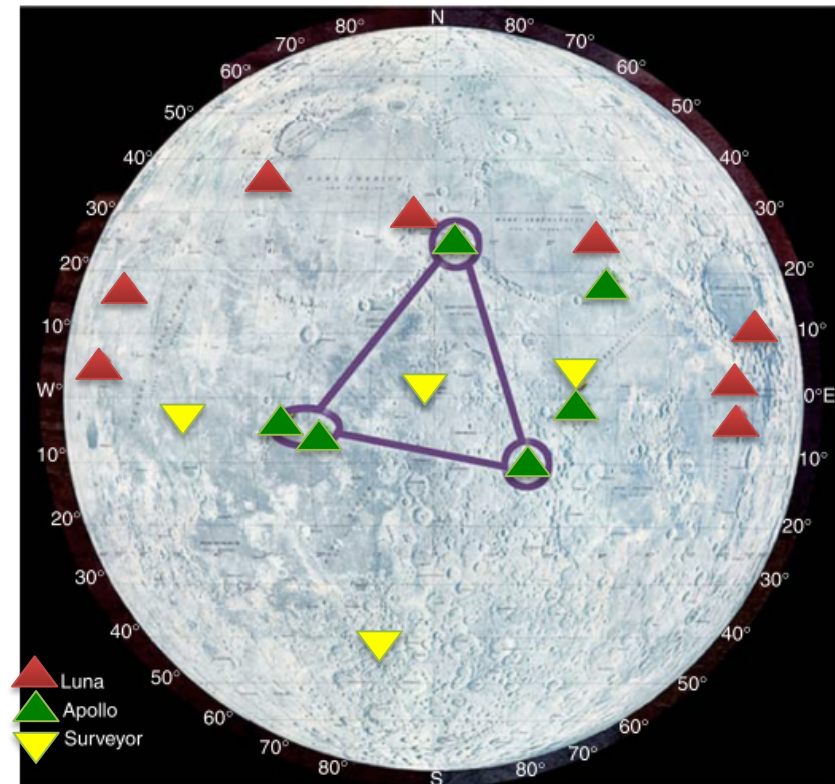

Lognonné, 2007, 10.03 Planetary Seismology, p. 73



# InSight Potential EM Sounding at Mars

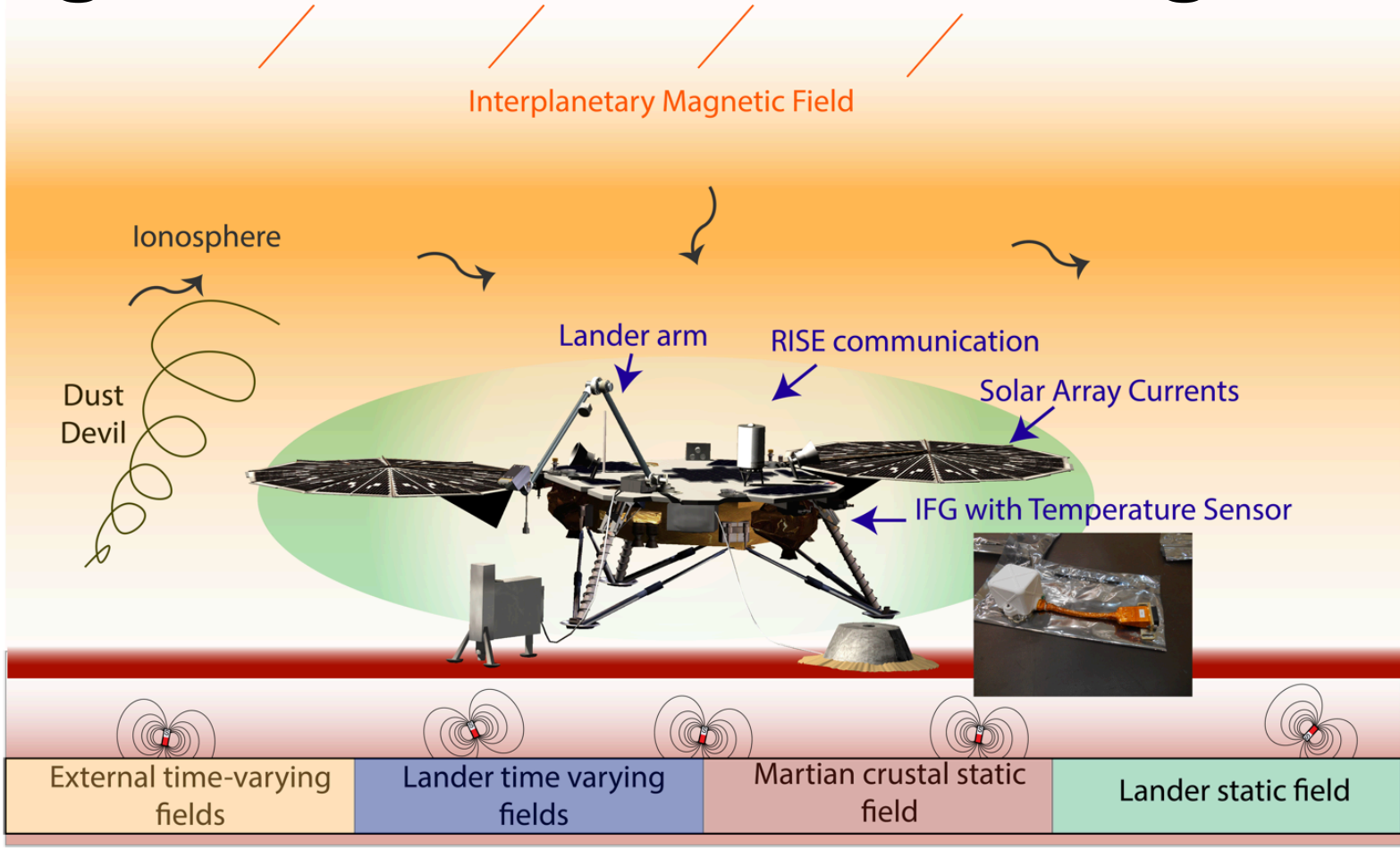

**Fig. S1 | Contributions to the Magnetic Field Measured by the IFG.** Time-varying fields are either of external origin (orange), including the interplanetary magnetic field, ionospheric currents and weather events such as dust devils; they can also be of lander origin (blue), e.g., due to movement of the arm, RISE communications, Solar Array Currents, or martian temperature variations, measured by the temperature sensors on the lander. The martian static crustal field (red) results from crustal magnetization, represented schematically here as subsurface dipoles. A DC field is also associated with the lander itself (green).



# Neutron Measurements at the Lunar Surface (NMLS)

## Mission Objectives:

1. Characterize the neutron radiation environment.
2. Provide in-situ ground truth for calibrating orbital data.
3. Provide constraints on composition (e.g., science & ISRU).
4. Monitor hydrogen cycle through lunar day.

## Project Description:

- Provide neutron counts at the lunar surface.
  - Deliver thermal and epithermal neutron rate counters using composite  ${}^6\text{Li}$ -doped scintillators.
  - Operate for ~8 Earth days, (~1/2 lunar daylight).
- Based on flight heritage (developed at MSFC), FNS instrument currently operating on the ISS, and in development for Gateway.

**Funding:** Lunar Discovery and Exploration Program (LDEP)

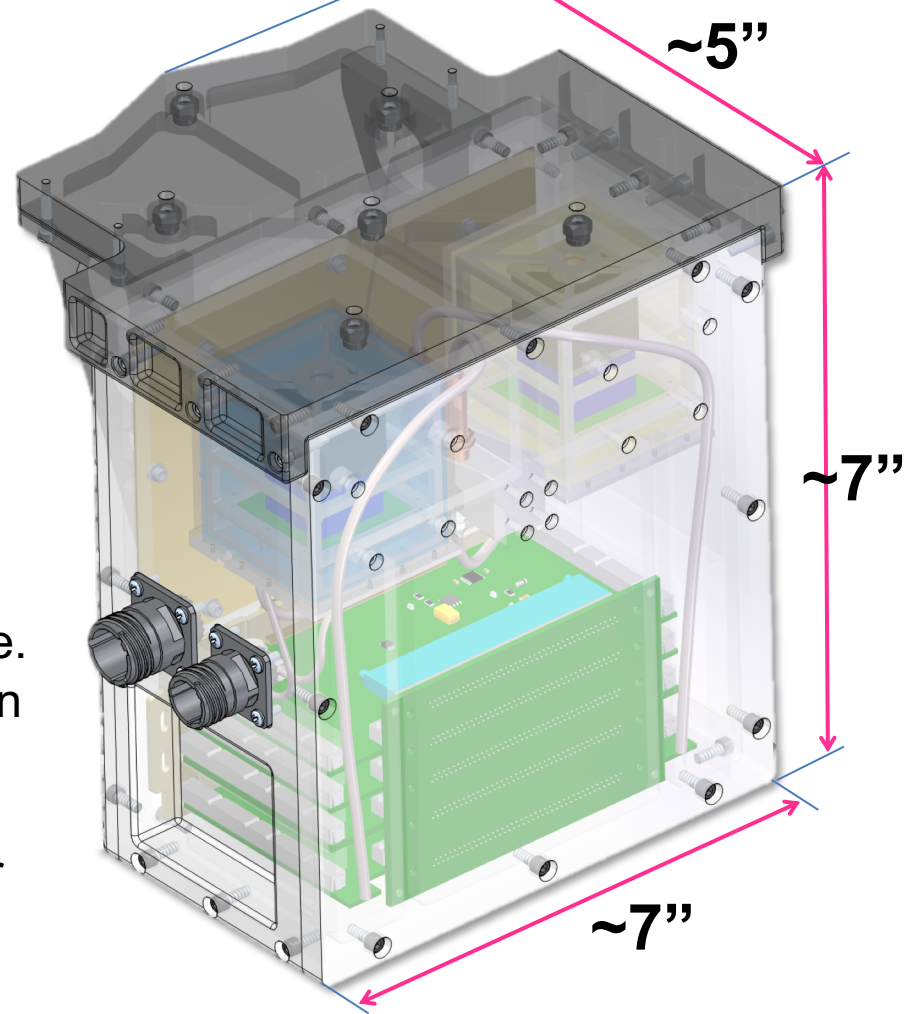

**NMLS Mechanical Model**

**Mass: ~4 kg**  
**Data rate: 10 bps**  
**Ave Power: 4.8 W**  
**Peak Power: 10 W**

# Questions?



# Summary of Apollo Lunar Electrical Conductivity Profiles

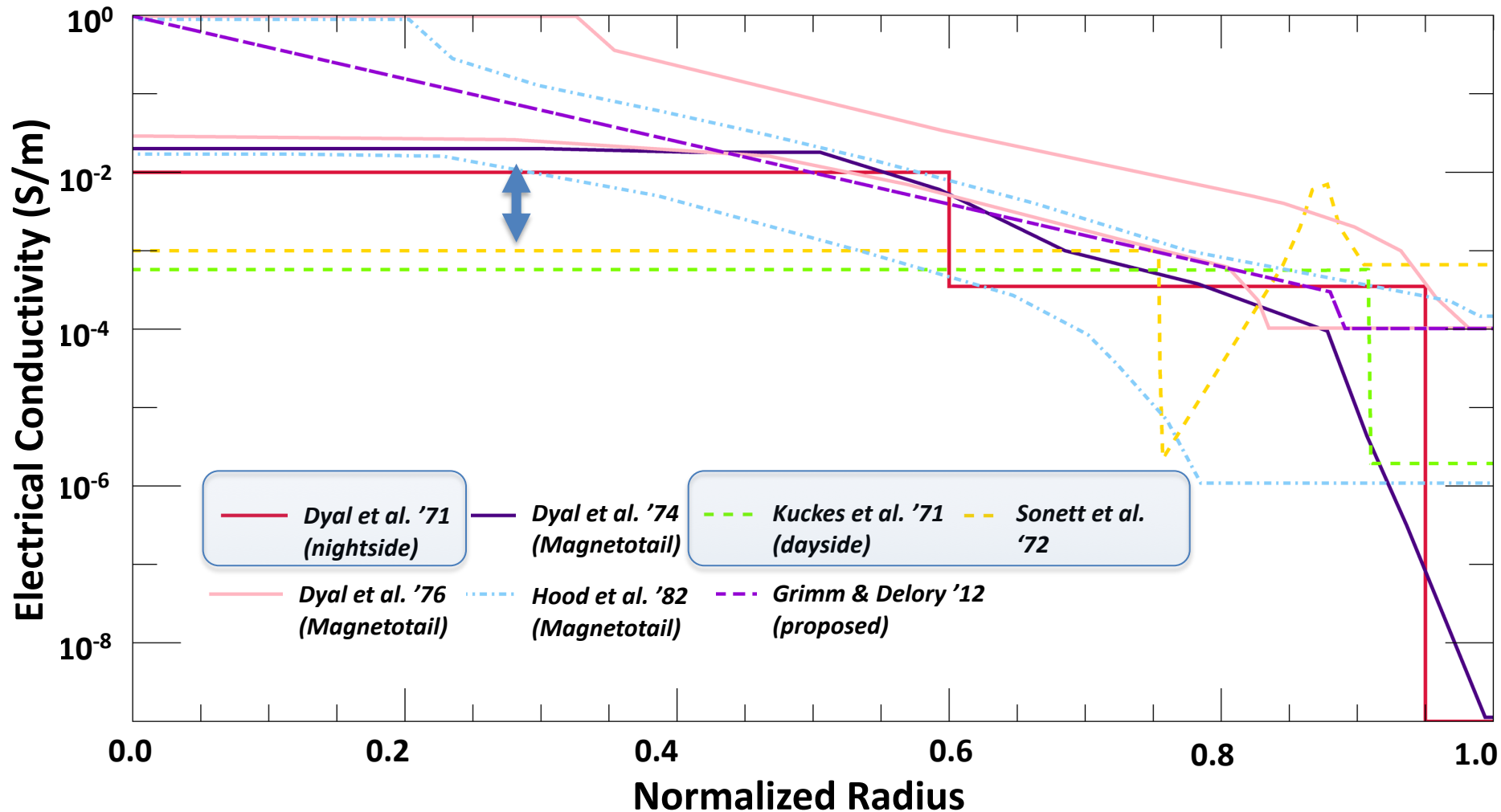



FIELD LINES

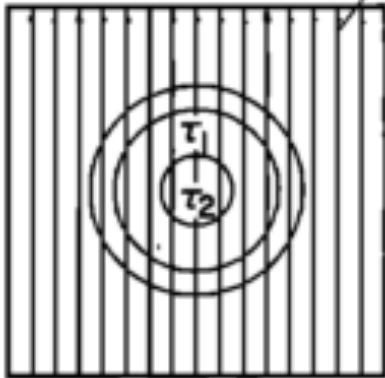

(a)  $t < 0$

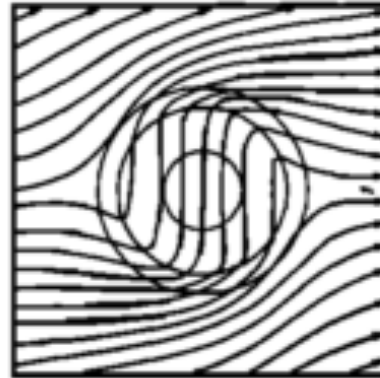

(b)  $0 < t < \tau_1 \ll \tau_2$

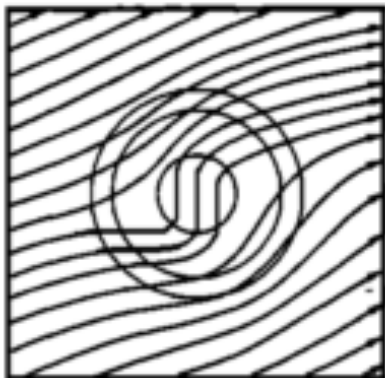

(c)  $\tau_1 < t < \tau_2$

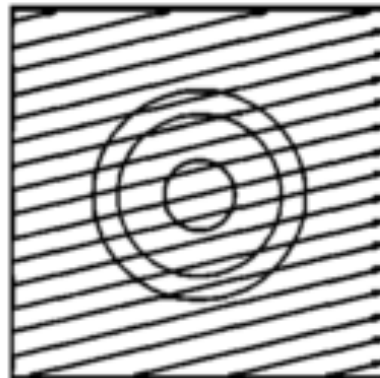

(d)  $t \gg \tau_2$