

FPMU (Floating Potential Measurement Unit)



International Space Station Spacecraft Charging Environments: Modeling, Measurement, and Implications for Future Human Space Flight Programs

Steve Koontz , John Alred, Erica Worthy, NASA Johnson Space Center, Houston, Texas, 77058

Emily Willis , NASA Marshall Space flight Center, Huntsville, Alabama, 35811

Courtney Steagall, William Hartman, Benjamin Gingras, William Schmidl, *The Boeing Company, Houston, TX 77059 USA*



Executive Summary

- **Hazard Cause - Accumulation of electrical charge on spacecraft and spacecraft components produced by:**
 - Spacecraft interactions with space plasmas, energetic particle streams, and solar UV photons (free electrons and photons typically drive these processes)
 - Spacecraft electrical power and propulsion system operations
- **Hazard Effects**
 - **Electrical discharges leading to:**
 - Radiated and conducted “static” noise in spacecraft avionics systems
 - Failure of spacecraft electrical power system components
 - Failure of spacecraft avionics (C&DH, C&T, GN&C) hardware
 - “Static” noise and possible hardware damage on docking of two spacecraft at very different electrical potentials (first contact bleed resistors don't always work here...)
- **Hazard Controls**
 - “Safe and verified design” – follow NASA and DoD standards and guidelines
 - Materials selection, grounding, bonding, and EMI/EMC compatibility, and screen for/eliminate potentially hazardous configurations, **verified during acceptance testing (not everyone knows what the requirement means or how to verify it)**
 - Active charging controls (e.g., plasma contactor units or something like that)
 - In-flight operational hazard controls (if all else fails and assuming there are any)
 - **“Test like you fly and fly like you test” (to the extent possible given schedule and budget constraints)**
- I there a high degree of similarity between ISS LEO natural or induced spacecraft charging environments and processes and those expected during cis-lunar and interplanetary missions?
 - **NO!**



Presentation Outline

- **Introduction and Background**
 - **Spacecraft Charging Environments and Processes**
 - **Spacecraft Charging Hazard Causes and Hazard Effects**
 - **Spacecraft Charging Processes and Dependencies**
 - **Space Plasmas and Energetic Particles**
 - **Some Examples of Spacecraft Charging Effects**
- **LEO/ISS Charging Environments, Processes, and Effects**
 - **Cold/high density plasma and geomagnetic field**
 - **ISS PV Array Driven charging**
 - **Motional EMF driven charging**
 - **Auroral Electron Charging in LEO and low (<1000 km) Polar Orbit**
 - **Surface and structure charging**
- **ISS Spacecraft Charging Measurement and Control**
 - **Plasma Contactors and the floating potential measurement unit**
 - **ISS in-flight charging measurements**
 - **Where else do we expect to encounter ISS/LEO charging environments beyond LEO?**
- **“Exploration” Spacecraft Charging Environments**
 - **Natural environments - Hot/low density plasma and energetic particles**
 - **Radiation belt transit, geo-tail, solar particle events**
 - **Spacecraft induced environments**
 - **Electric propulsion system operations**
- **So what do I do about all this and what happens if I don't?**
- **Summary and Conclusions**



Spacecraft Charging Environments and Processes: Introduction and Background

Spacecraft Charging Environments and Processes: General Principles

Why do we care about this?



- **Safety, Reliability, and Mission Success**
- **If not accounted for during spacecraft design development and test:**
 - You may get lucky and operate successfully via workarounds
 - Or you may fail to achieve mission objectives, operational reliability requirements, or in extreme cases, lose the entire spacecraft (e.g., ADEOS-II and DSCS-9431)
- The most common **hazard effects** of the spacecraft charging **hazard cause** are:
 - Avionics system failures and anomalies
 - Electrical power system failures and anomalies
 - Surface performance property degradation caused by arcing
 - Increased attitude control propellant use rates (energetic surface arcing can be propulsive)

Table 1. Distribution of Records by Anomaly Diagnosis

Diagnosis	Number of Records
ESD—Internal Charging	74
ESD—Surface Charging	59
ESD—Uncategorized	28
Single-Event Effects	85
Damage	16
Micrometeoroid/Debris Impact	10
Miscellaneous	26

Aerospace Corp. Report TR-2000(8570)-2; 28 February, 2001

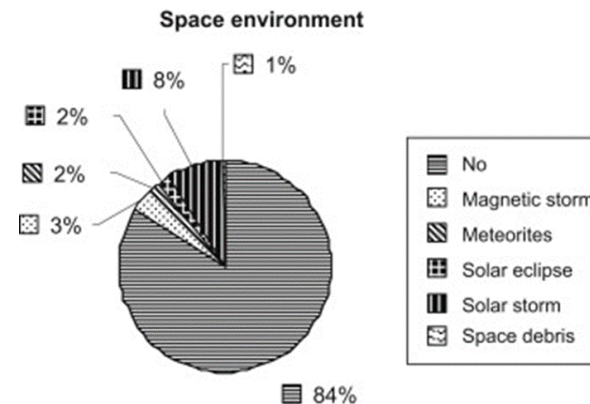

Mak Tafazoli; "A study of on-orbit spacecraft failures,"
Acta Astronautica, Volume 64, Issues 2–3, 2009, 195–205
See back-up for more on this)



Spacecraft Charging Environments and Processes: Spacecraft Charging Summary



- **Spacecraft Charging:**
 - Processes that produce an electrical potential or voltage difference between the spacecraft and the surrounding space plasma environment (**absolute charging**) and/or voltage differences between electrically isolated parts of the spacecraft (**differential charging**)
- Electrical potential differences result from the separation of positive and negative charges, in the spacecraft, in the flight environment, or both with accumulation of an excess of one charge on the spacecraft or spacecraft components.
 - **Current balance equations** model the ion and electron currents to and from the spacecraft
- During charging and discharging, electrical currents will flow through or onto various parts of the spacecraft, and those currents can be damaging.
 - Simple resistor/capacitor charging circuits can give you a feel for how this works (examples later in this presentation)
 - **Conductors and dielectrics charge and discharge in very different ways**



Spacecraft Charging Dependencies:

Spacecraft mission environment,
materials, configuration, con-ops



- **Spacecraft mission environments and velocity with respect to plasma or local magnetic fields**
 - Flight environment and mission timeline determine charging processes
- **Spacecraft current and voltage sources interacting with the local environment**
 - Can drive current collection to and from the space plasma environment
- **Area of spacecraft metallic material exposed to energetic charged particle flux or ambient plasma**
 - Current collection into spacecraft conducting structure and circuitry
- **Electrical properties of spacecraft materials**
 - Secondary and photoelectron emission characteristics of the spacecraft materials
 - Dielectric materials conductivity
 - Dielectric material relaxation time
 - Dielectric breakdown voltage
 - Are dielectrics static dissipative?

Spacecraft Charging Environments and Processes: General Principles.

Internal vs. Surface Charging



- Electron kinetic energy is of primary importance here (protons are believed to be less important)
- Surface charging: 0 to 50 keV
 - Solar UV photoelectron emission from spacecraft surfaces
 - I_e = electron current incident on spacecraft surface(s)
 - I_{ph} = photoelectron current from spacecraft surfaces in sunlight, **typically (material dependent) on the order of 10^{-9} amps/cm² at Earth orbit** and decreases as distance from the sun increases ($1/R^2$)
 - If $I_{ph} > I_e$, spacecraft surfaces charge to small positive values ($\sim +10V$ to $+20V$)
- Surface to internal charging transition: 50 to 100 keV
 - Not mitigated by solar UV photoelectron emission
- Internal charging > 100 keV
 - Not mitigated by solar UV photoelectron emission
- Practical range of concern for GEO/cis-Lunar orbits:
 - 0.1 to 3 MeV assuming ~ 0.08 to 0.3 cm Al shielding
 - Generally not a concern in LEO except at high (>60 degrees) latitude
- “Grounded” conducting structure can also be a charging target and spacecraft electrical systems operations can be a charging cause



Spacecraft Charging Environments: Space Plasmas and Energetic Particles

- **Plasma – an ionized gas that conducts electricity**
 - **Consists of neutral atoms/molecules, electrons (e^-), and ions (i^+)**
 - Displays collective behavior (plasma, not just an ionized gas) if -
 - **Debye Length (λ_d) \ll L (length of system), and Plasma Parameter (Λ) \gg 1**
 - **Gas Kinetic Theory (Maxwell-Boltzmann Equation) applies**
 - All particles in a gas have the same temperature at equilibrium
 - So all particles have the same average kinetic energy; $v_{avg} = [(2 k T_i)/(m_i)]^{1/2}$
 - $KE_{avg} = \frac{1}{2} m v_{avg}^2 \Rightarrow$ particle speed depends on mass
 - **All else being equal, electrons much faster than ions so that objects in the plasma tend to charge negative relative to the plasma in a way that depends on electron temperature and electron/ion mobility;**
 - **Important Plasma Parameters**
 - **λ_d - Plasmas can rearrange charges to exclude electric fields, like any conductor**
 - ω_{pe} - Electron Plasma Frequency
 - Λ - Need a large number of particles inside the λ_d length for collective behavior
 - FP - Floating potential of an object in the plasma
- **Energetic Particles**
 - **Auroral Electrons, Relativistic Trapped Electrons, SPE Electrons and Protons**
 - **Not a plasma effect - more like a high voltage power supply driving current onto and into the spacecraft**

Space Plasma Environments – The Numbers



E. C. Whipple, "Potentials of Surfaces in Space," Reports on Progress in Physics, Vol. 44, pp. 1197-1250, 1981

Plasma	Density $n_e(m^{-3})$	Electron Temperature T(K)	Magnetic Field B(T)	Debye Length $\lambda_D(m)$	Electron Plasma Frequency (MHz)	Small Object FP (V)
Gas discharge high density/hot	10^{16}	10^5	--	10^{-4}	1000	-10
Ionosphere high density/cold (ISS)	10^{12}	10^3	10^{-5}	10^{-3}	10	-1
Magnetosphere low density/hot (Orion/Gateway worst case and and Extreme Interplanetary*)	10^7	10^7	10^{-8}	10^2	0.01	Day, +10 Night, -10K
Solar wind low density/hot (Nominal Interplanetary)	10^6	10^5	10^{-9}	10	0.01	Sun, +10 Eclipse, -20

* Solar Particle Event and/or Coronal Mass Ejection passage

Spacecraft Charging Environments and Processes: Metal structure with thin dielectric coating – ISS MM/OD shields



- 1) Active electron (-) collection by ISS PV arrays **drives ISS conducting structure to negative FP**
- 2) Ionospheric ions (+) attracted to negative structure and produce positive charge on thin dielectric (anodized Al) surface coatings
- 3) Dielectric breakdown arc plasma provides conductive path for capacitor discharge and degrades PTCS on MM/OD shields with both conducted and radiated EMI

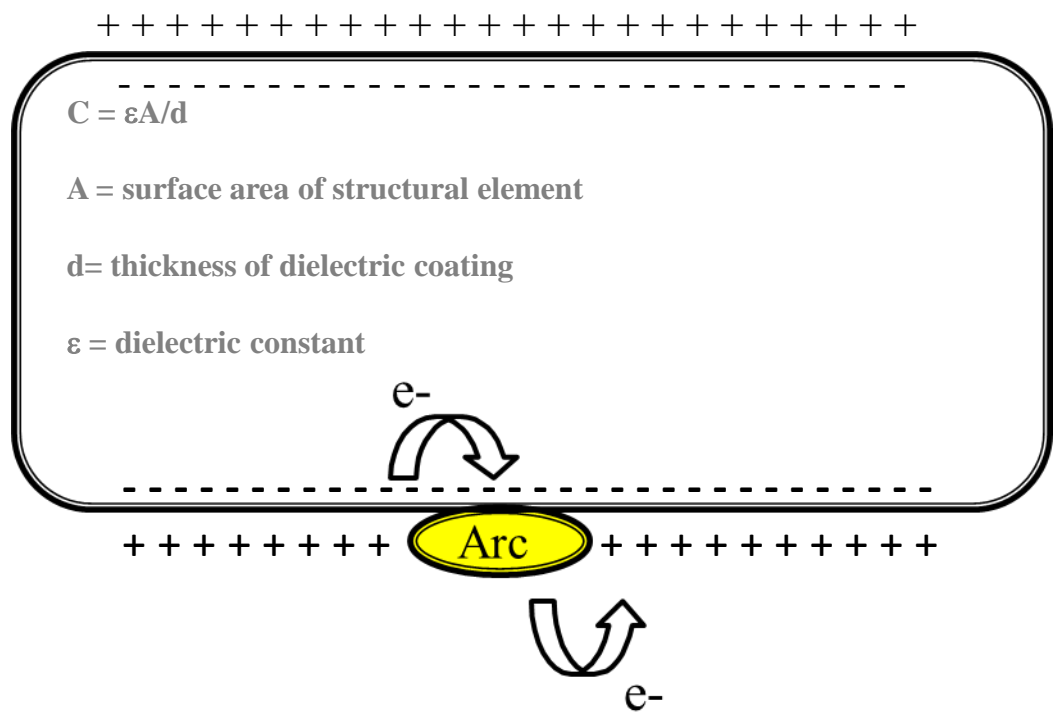

Spacecraft Charging Environments and Processes: Summary

Dielectric breakdown in LEO

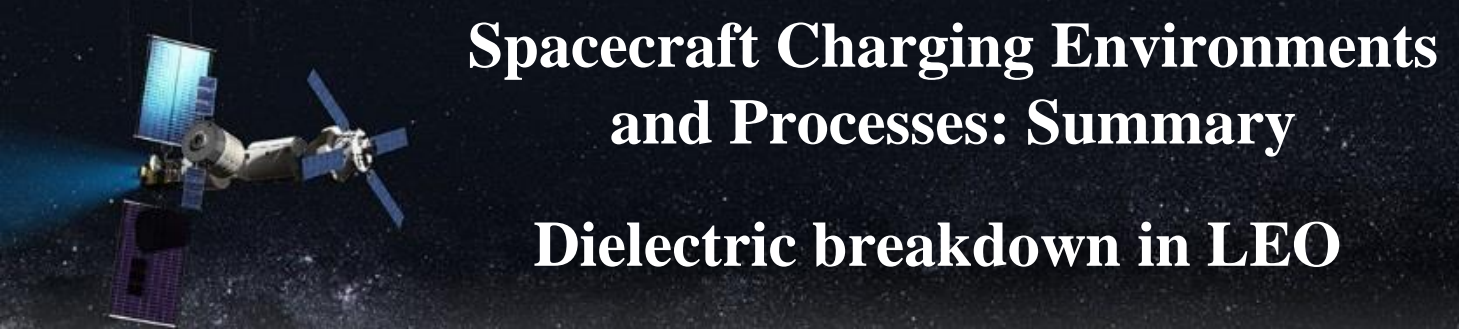

Arc damage in laboratory tests of the chromic acid anodized thermal control coating covering ISS orbital debris shields.
Credits: NASA/T. Schneider

ESA EURECA satellite solar array sustained arc damage.
Credits: ESA

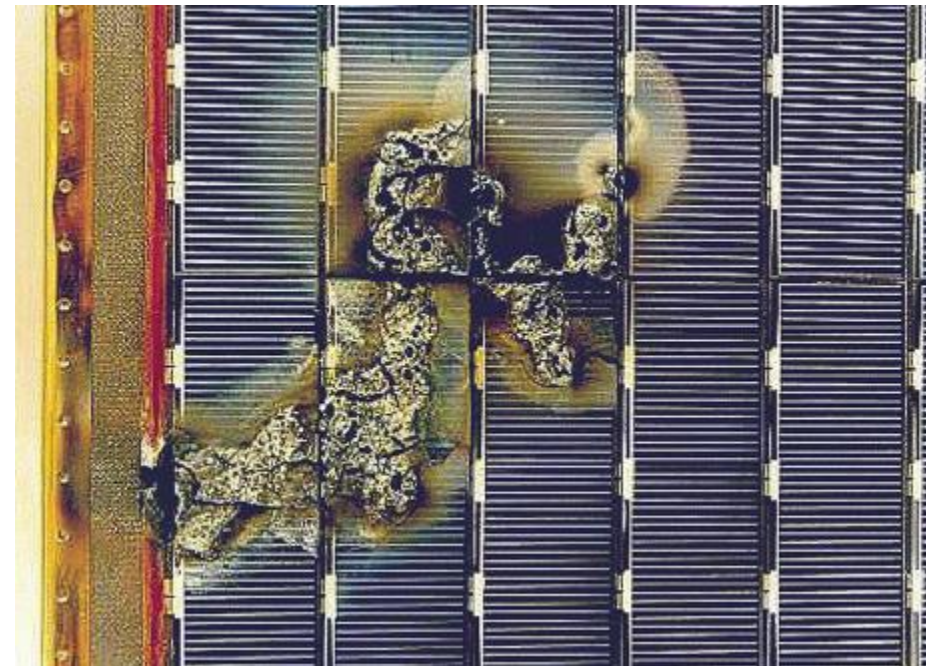

<https://www.nasa.gov/offices/nesc/articles/understanding-the-potential-dangers-of-spacecraft-charging>

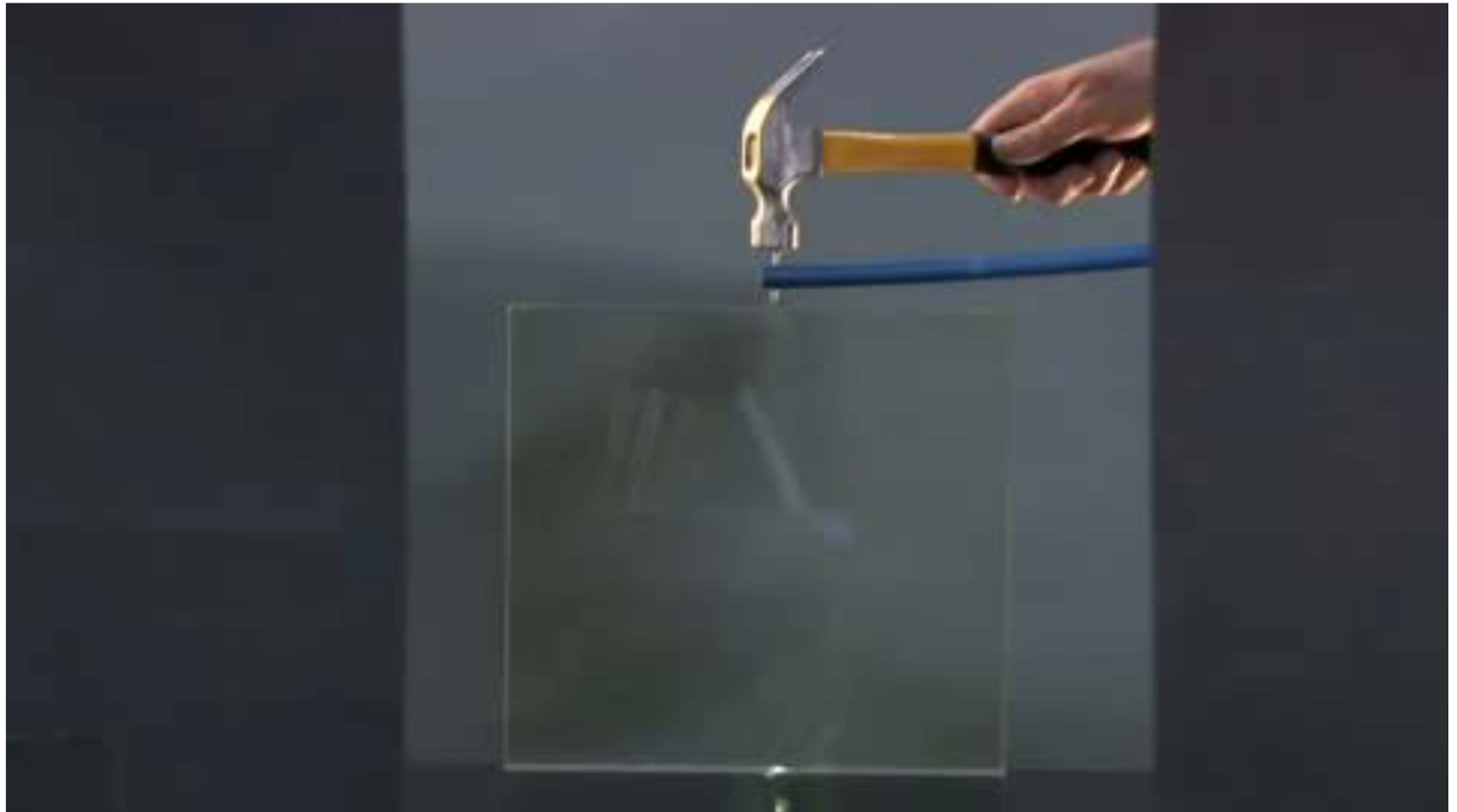
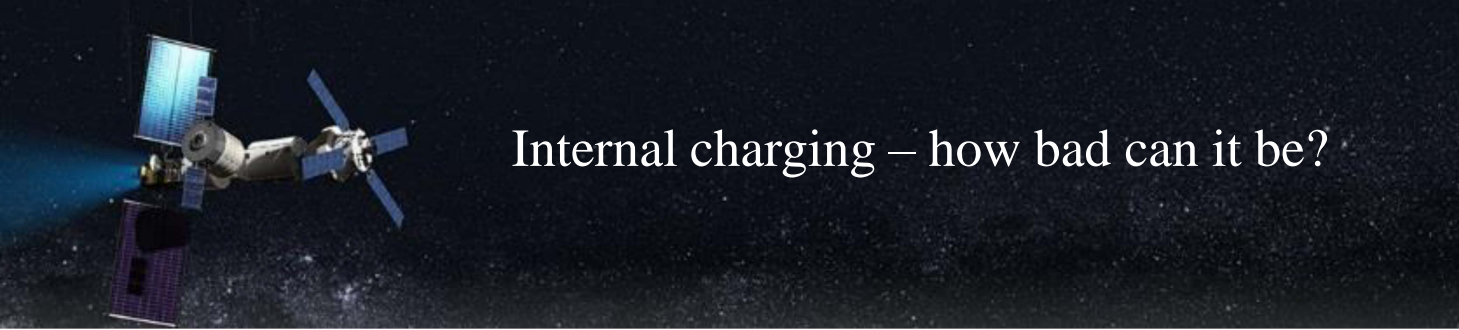

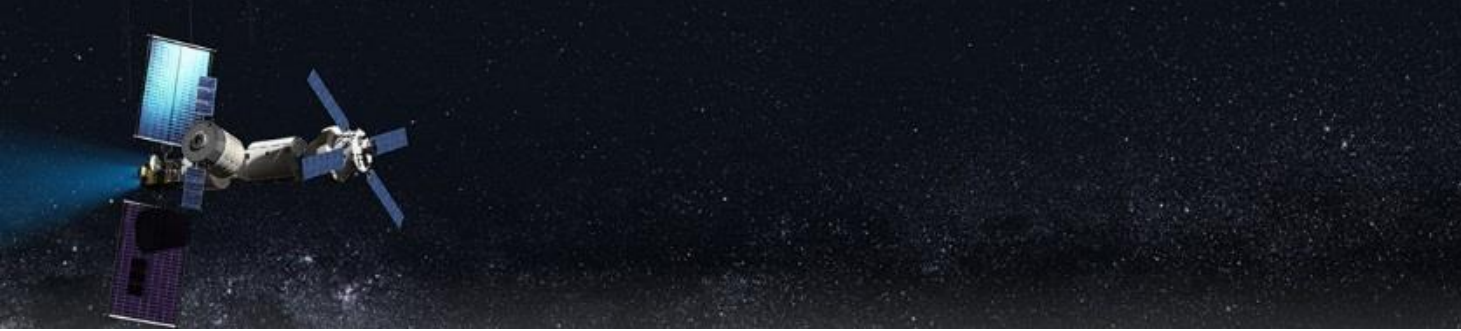

LEO/ISS Charging Environments, Processes, and Effects

LEO Ionospheric Plasma and Geomagnetic Field Charging Environments

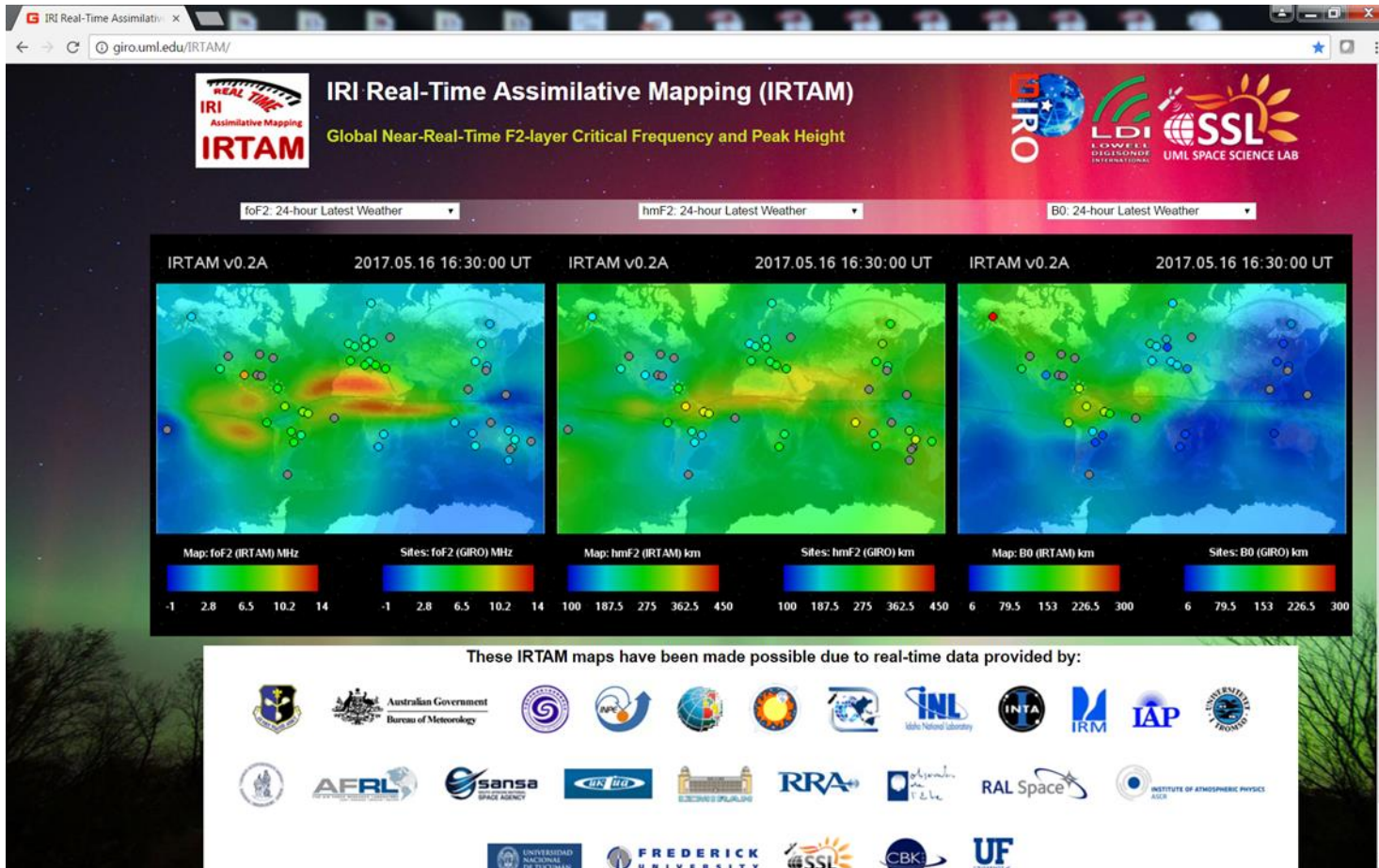

$$f_c = 9\sqrt{N_e} ; f_c, \text{Hz}; N_e, e^-/m^3$$

<http://giro.uml.edu/IRTAM/>

LEO: Ionospheric Plasma and Geomagnetic Field Charging Environments

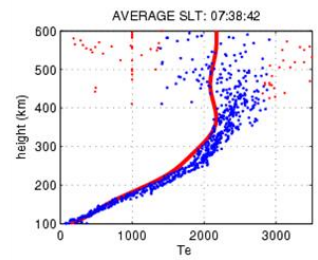
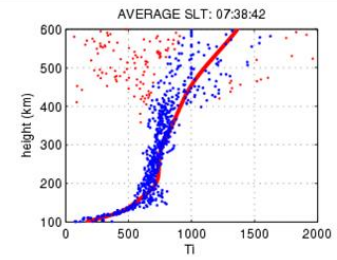
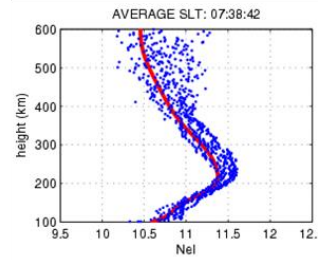
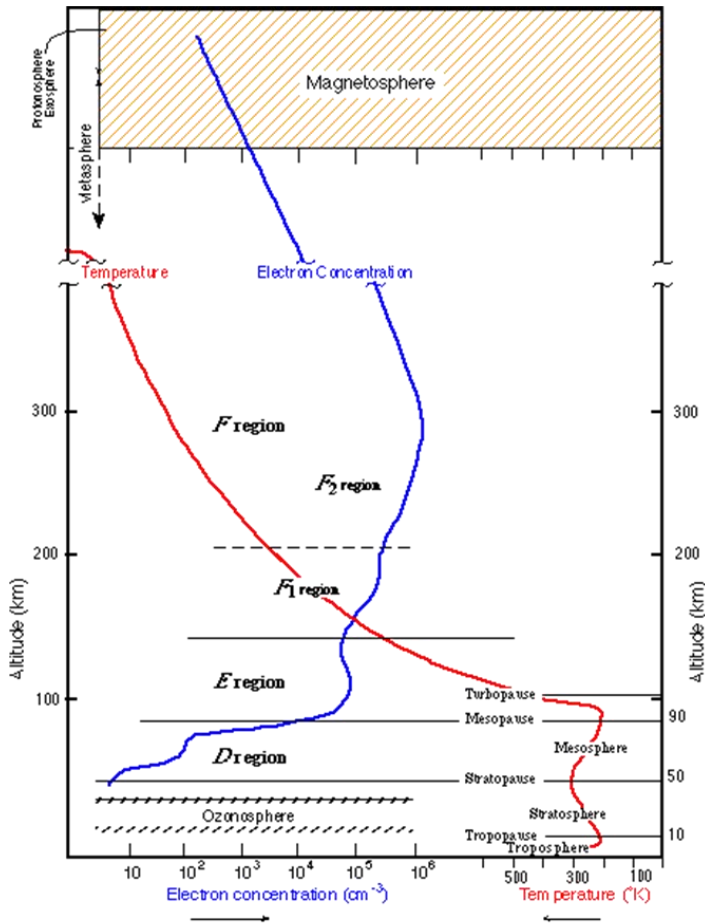

ISR Data and Model
for Millstone Hill
in the last 1 hour (A/C)
(red for SNR < 0.15 & 35% off model)

F107 = 74
ap = 4
Current Local Time 30-Sep-2005 09:00:17

A Simple Worked Example: Solar Array Driven Charging in LEO (~ ISS)

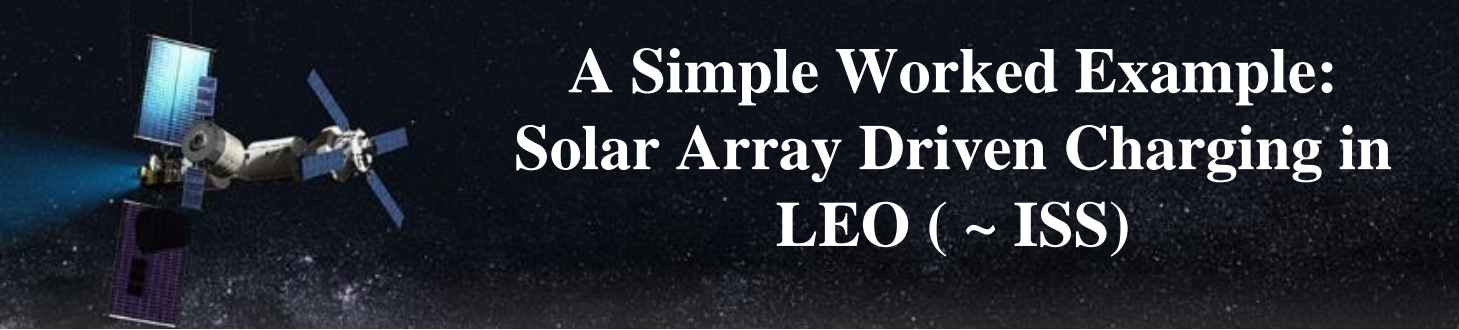

- 1) Rectangular PV array (**length L, width W**) and **string voltage V** (end-to-end) in sunlight, with exposed metallic PV cell interconnects, a negative structure ground, and negligible capacitance.
- 2) We want to calculate the Floating Potential (**FP, the voltage difference between a point on the PV string and the surrounding ionospheric plasma**) as a function of position along the string.
- 3) **Now, calculate the steady-state current balance, $J_i = J_e$.**

$$J_i = N_i q v_i A_i \quad \text{and} \quad J_e = 0.25 N_e q v_e A_e;$$

$$v_i = V_{ISS} = 7.7 \text{ km/sec} \quad \text{and} \quad v_e = 163 \text{ km/sec} \quad (\text{corresponding to } T_e = 0.1 \text{ eV})$$

$$A_e/A_i = L_e/L_i = v_i/0.25v_e = 7.69/40.75 = \mathbf{0.19};$$

- 4) **The electron collecting area is a small fraction of the total area (and length) at steady-state and we can calculate FP voltage at each point along the PV array with this simple “toy” model.**
- 5) For a **160V string**, the FP at the negative structure ground is about **-130V** and the FP at the positive end is about **+30V**.
- 6) This simple calculation works well for UARS, HTV, and many other LEO satellites (even DMSP when ionospheric density is high enough at 800 km)
- 7) This is not what we see on ISS (worst case maximum expected is -80 volts and that very, very rarely) – **WHY?**

A Simple Worked Example: Solar Array Driven Charging in LEO (~ ISS)



ISS doesn't embody the assumptions underlying the simple model

- While it is true that $A_e/A_i \ll 1 \Rightarrow R_i \gg R_e$, but in fact $R_i > R_e$ because:

- 1) ISS has significant exposed conducting structure to increase ion collection
- 2) ISS PV array electron collection is limited by burying PV cell metallic interconnects and current collection busses in dielectric
- The steady-state assumption is not valid given the size of the charging currents and the size of the ISS capacitor
 - 3) ISS capacitance $\gg 10^9$ pF
- ISS FP is modeled accurately (for EVA safety assessments) using the Boeing Plasma Interaction Model (PIM)

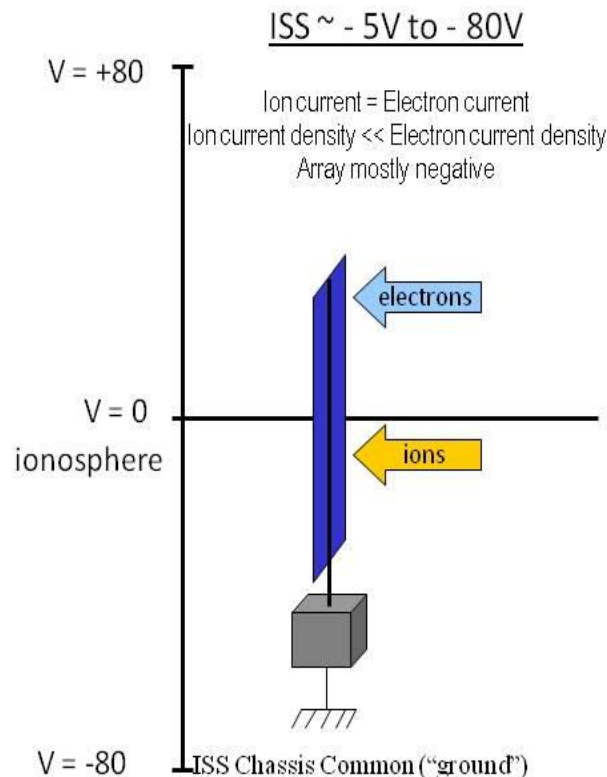

Circuit

$$I_e + I_i = 0$$

$$\frac{V+160}{R_e} + \frac{V}{R_i} = 0, R_i > R_e$$

$$V = -160 \left(\frac{R_i}{R_i + R_e} \right) \approx -5 \text{ to } -80 \text{ Volts}$$

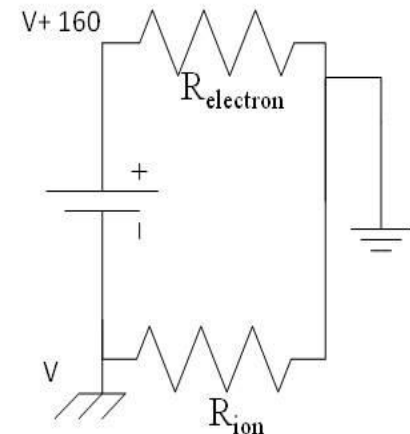

LEO Ionospheric Plasma and Geomagnetic Field Charging Environments

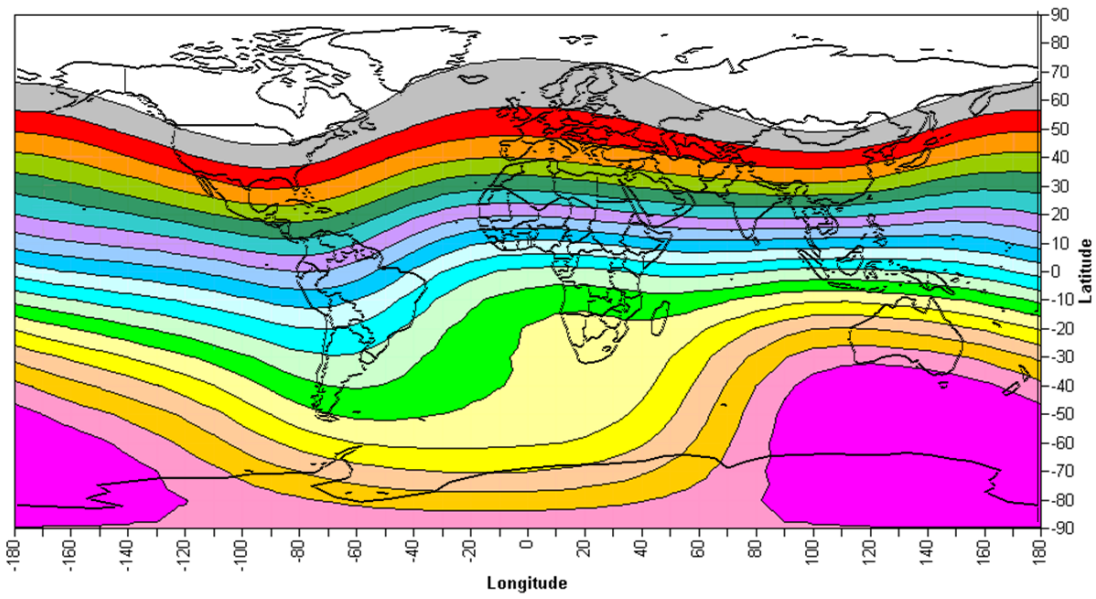

Magnetic Field B_z (Gauss)

0.5-0.45	0.45-0.4	0.4-0.35	0.35-0.3	0.3-0.25	0.25-0.2	0.2-0.15	0.15-0.1	0.1-0.05	0-0.05
0.05-0.1	0.1-0.15	0.15-0.2	0.2-0.25	0.25-0.3	0.3-0.35	0.35-0.4	0.4-0.45	0.45-0.5	

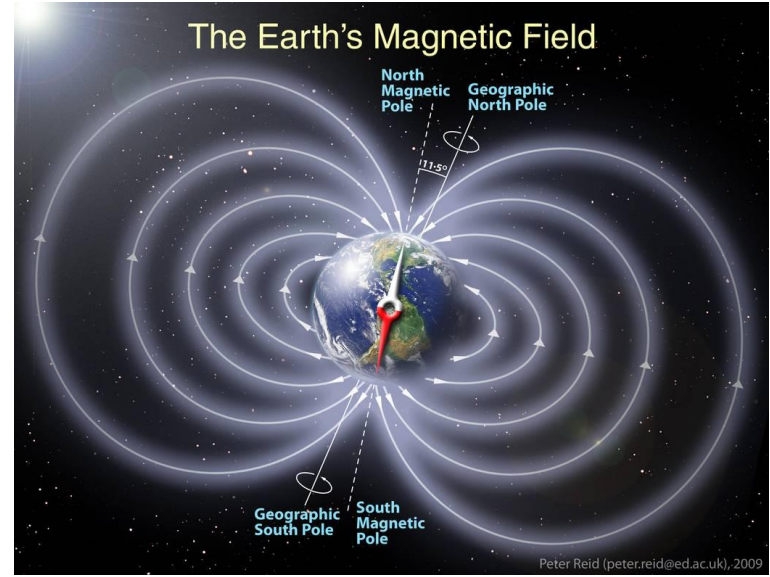

Peter Reid (peter.reid@ed.ac.uk), 2009

Another Simple Worked Example: Motional EMF (magnetic induction charging) of ISS at high latitude



Flying large metallic structures in LEO can lead to large motional EMF voltages across the structure as a result of the Lorentz force: $V = (\mathbf{v} \times \mathbf{B}) \cdot \mathbf{L}$

- V = end-to-end voltage the spacecraft length $L = 100$ m for ISS Truss
- v = spacecraft velocity = 7.67 km/sec
- B = geomagnetic field vector
- 400 km altitude and orbital inclination $51.6^\circ \Rightarrow V \sim 50$ V at high latitude
- Using the same simple, approximate charge balance analysis used for solar-array driven charging and 50 V instead of 160 V, the area ratios will be the same, with the negative end at about - 42 V and the positive end at about + 8 V
- **Motional EMF depends on orbital velocity and decreases with increasing altitude. Motional EMF is ~ 0 at GEO and in cis-lunar space**

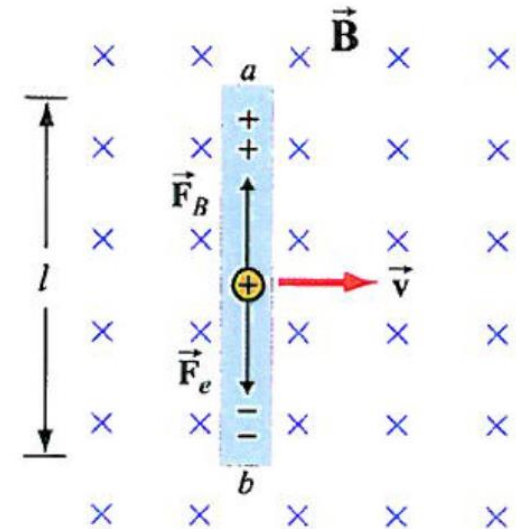
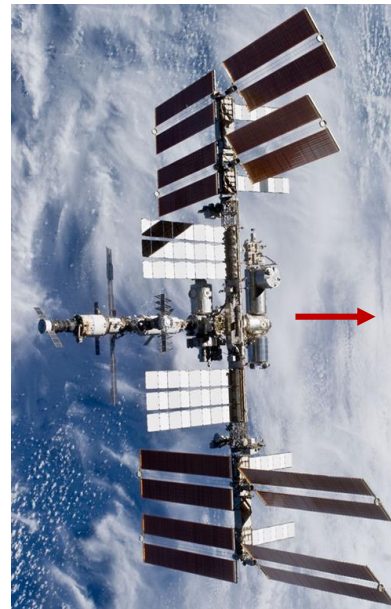

Spacecraft Charging Environments: Geomagnetic Storm and Aurora



Video Simulation Credit NASA GSFC

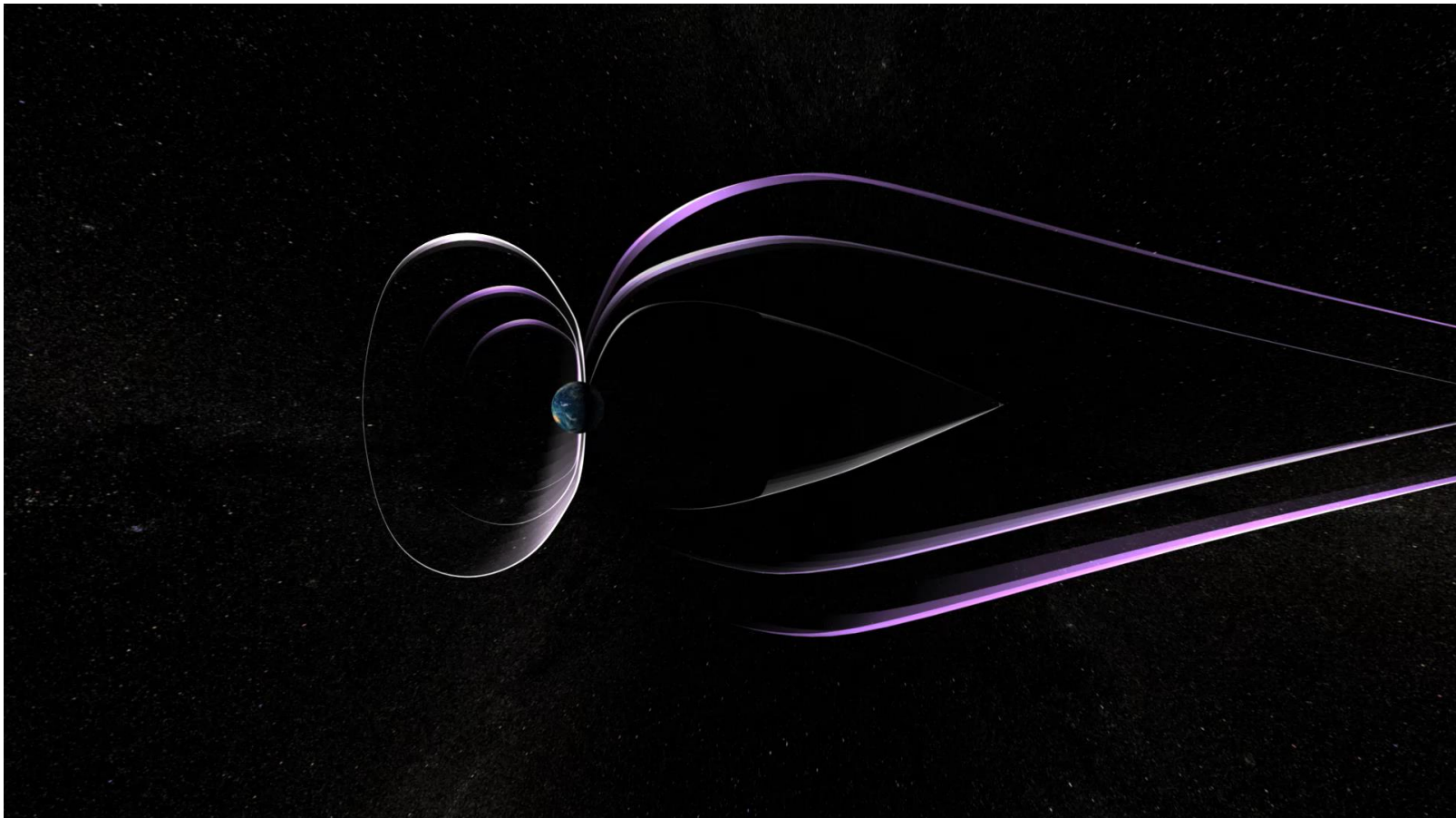



LEO ISS Auroral Charging Environments



“11:30: Transited through a very unusual aurora field. Started as a faint green cloud on the horizon, which grew stronger as we approached. Aurora filled our view field from SM (Service Module) nadir ports as we flew through it. A faint reddish plasma layer was above the green field and topped out higher than our orbital altitude.”

Excerpt from ISS Commander William Shepherd’s deck log of Nov. 10, 2000

Directly Over Aurora Australis

Videos produced by the Crew Earth Observations group at NASA Johnson Space Center

For replication and crediting information, please see our guidelines on our main video page.

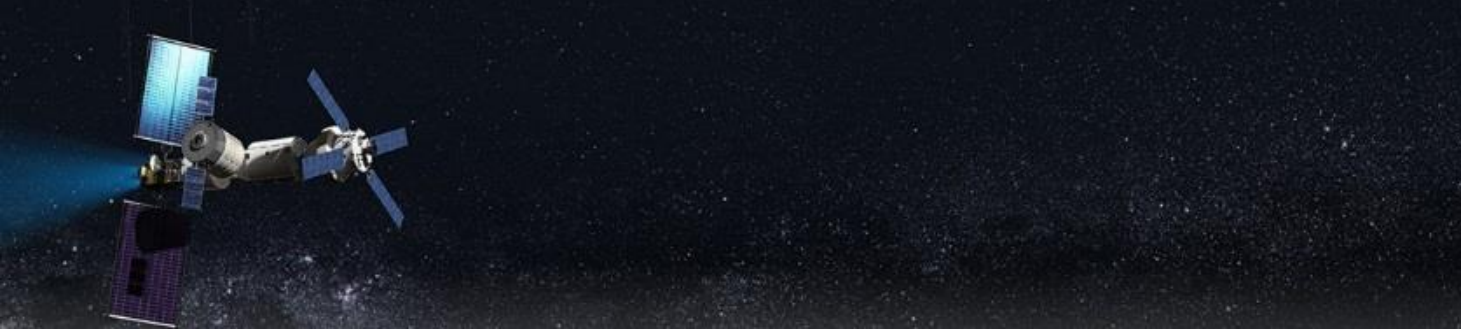

ISS Spacecraft Charging Measurement and Control

ISS Charging Measurements: Floating Potential Measurement Unit - 2006 to 2018

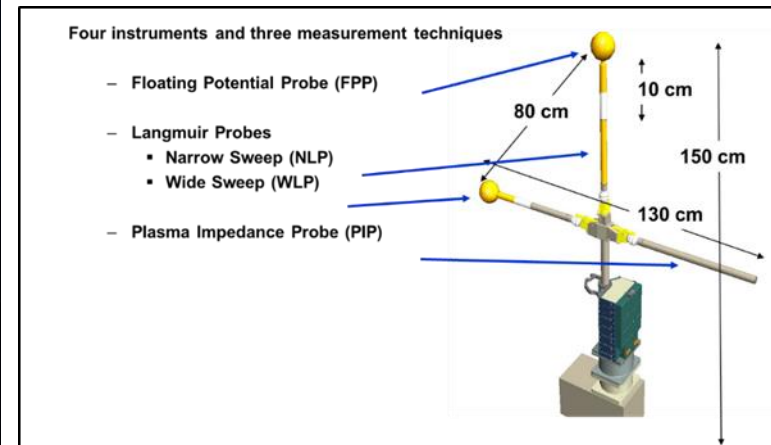
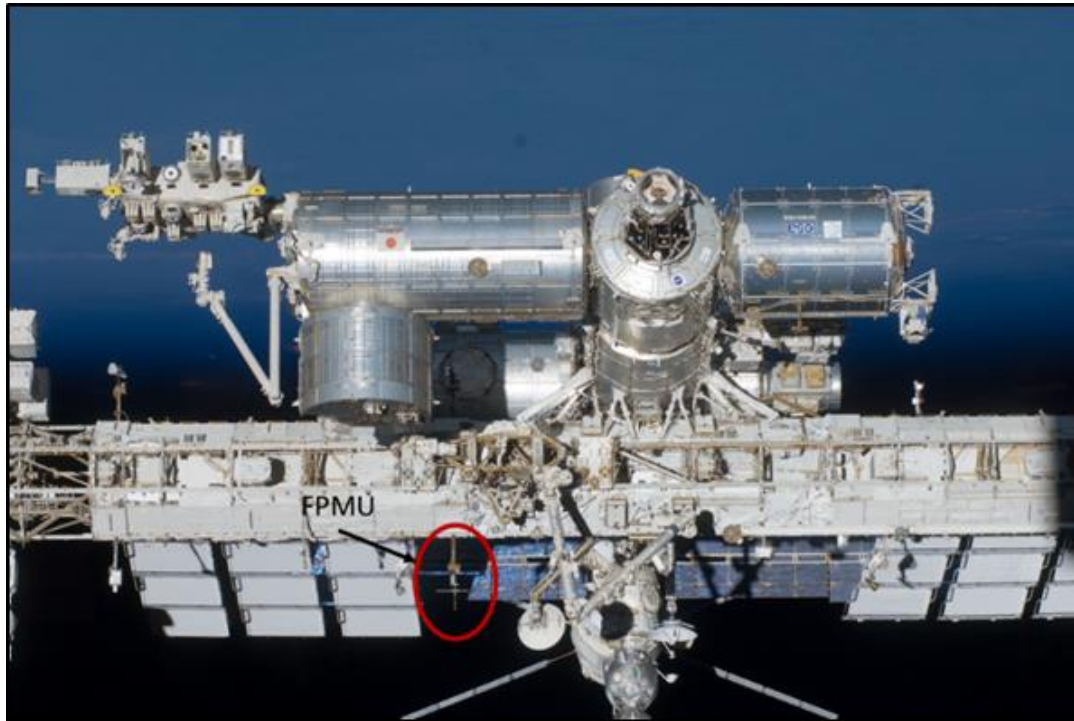

Note: The FPMU measures floating potential of conducting structure only, and does not measure surface charging

FPMU Instrument Data Validation

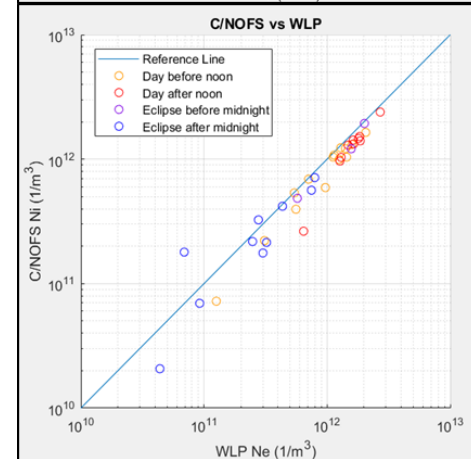
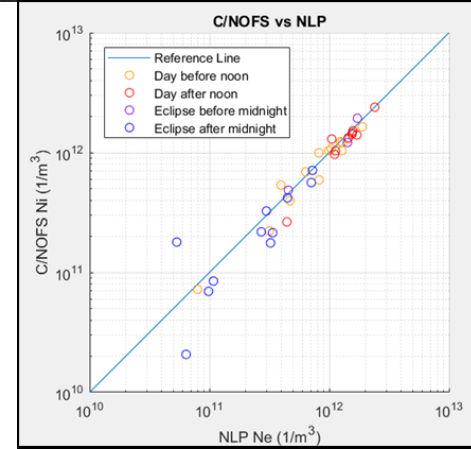
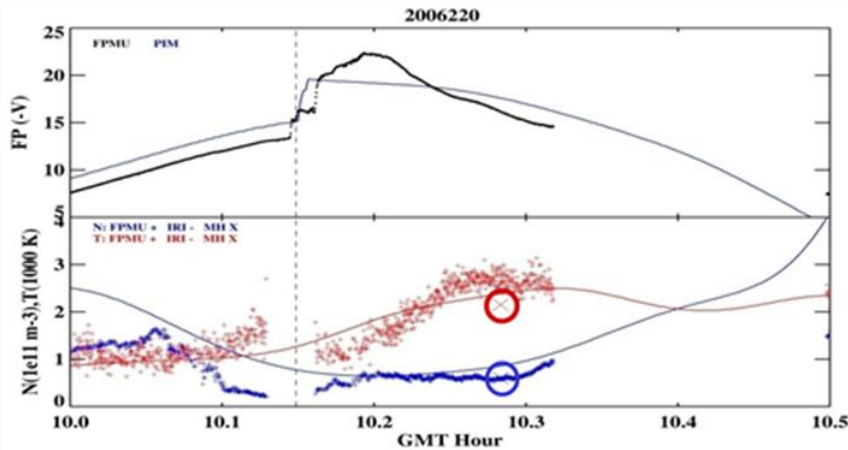
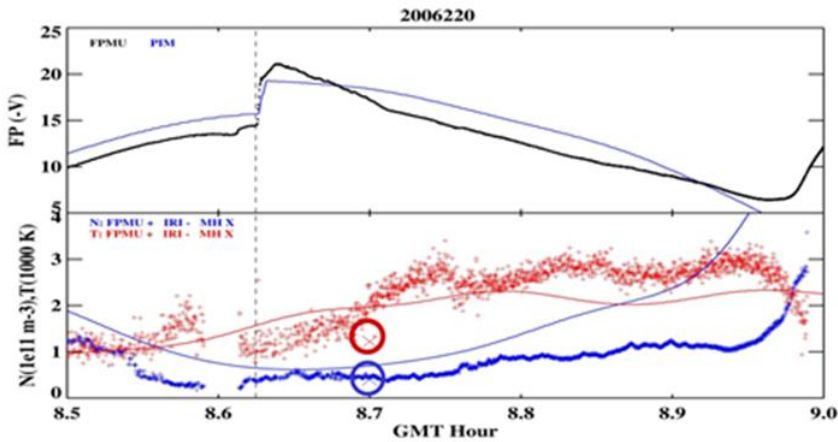

FPMU measurements of ionospheric density and temperature compared to Millstone ISR measurements made during an ISS overflight. Red refers to ionospheric temperature and blue to ionospheric density.

C/NOFS Coupled Ion-Neutral Dynamics Investigation (CINDI) Instrument Ni measurements compared with FPMU Langmuir Probe (WLP and NLP) Ne measurements.



Typical FPMU Data: ISS Floating Potential



- ISS was in the +XVV flight attitude for these measurements
- As ISS enters sunlight at the eclipse exit point of its orbit, the solar arrays are facing forward and charging ISS batteries and are completely unregulated. They are optimally configured to collect ionospheric electrons
- As ISS batteries approach a fully charged state, solar array downregulation begins so as not to overcharge the batteries
- If nominally sun tracking, the PV arrays will no longer be facing forward after orbital noon and wake effects will further suppress electron collection
- Peaks in the FP are sometimes observed as the ISS flies through high Ne regions, like the Appleton Anomaly, if the PV arrays are still facing forward and illuminated at orbital noon

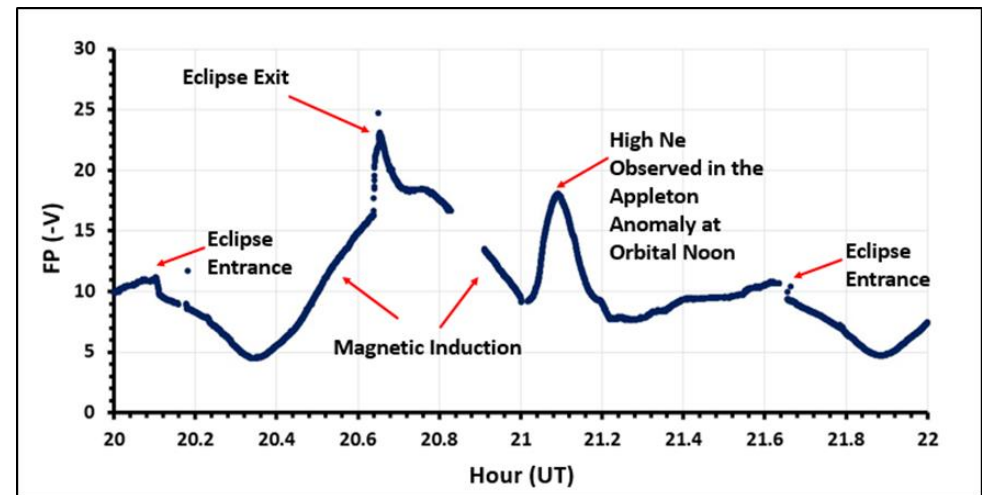
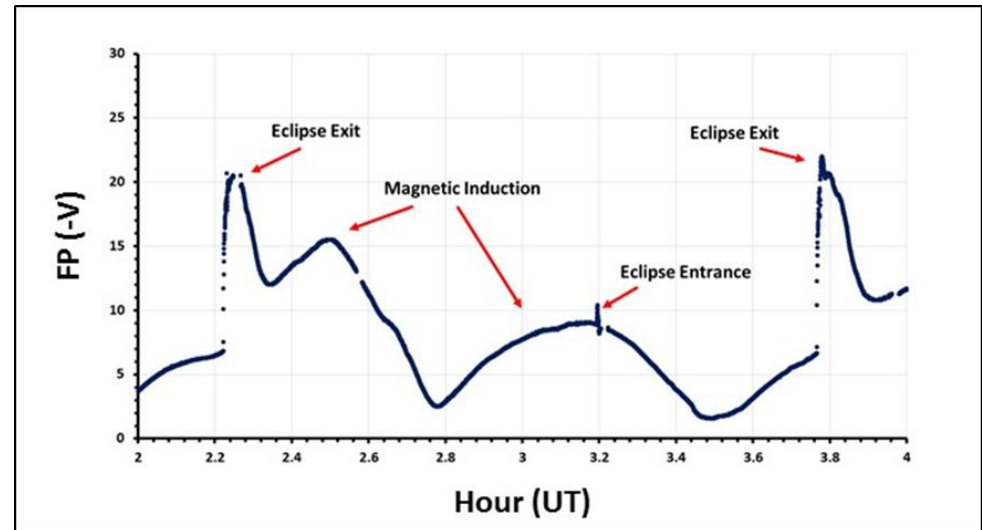

ISS Plasma Interaction Model (PIM) performance

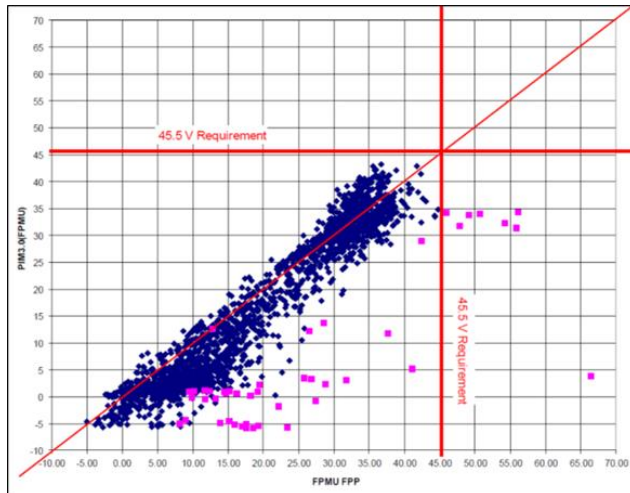
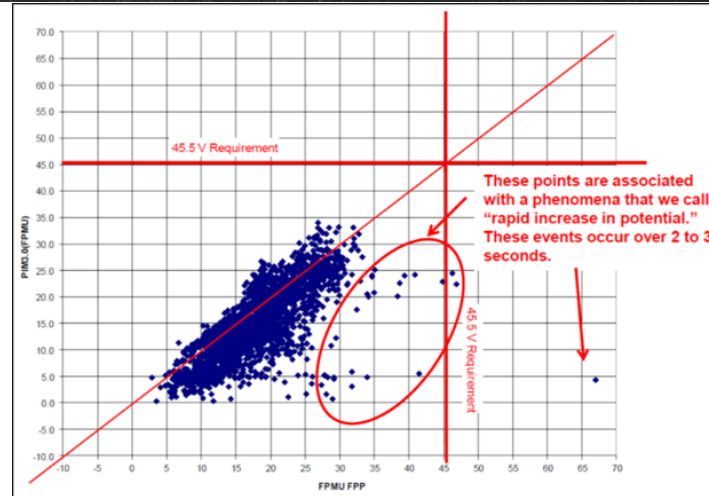

ISS FP at the Starboard Truss tip location and FP values calculated for that location using the PIM ISS charging model

ISS FP at the FPMU location and FP values calculated using the PIM ISS charging model

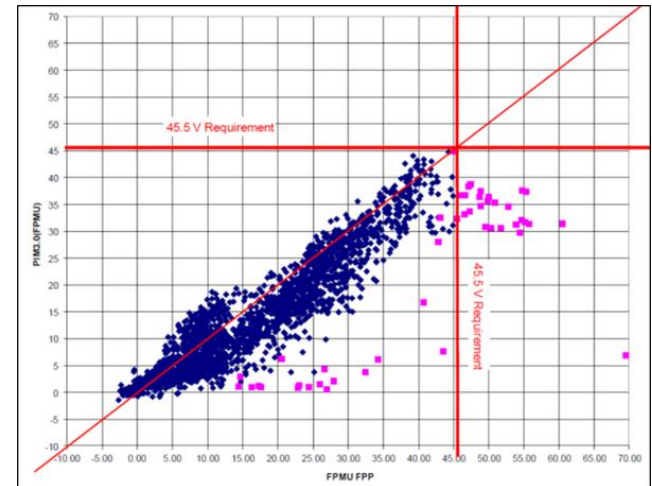

ISS FP at the Port Truss tip location and FP values calculated for that location using the PIM ISS charging model

ISS Charging Measurements: Floating Potential Measurement Unit - 2006 to 2017



Solar Array Un-shunting (and Power on Reset, POR) Impact on ISS FP. Other rapid FP increases have been observed without un-shunt or POR (correlated with very low ionospheric plasma density)

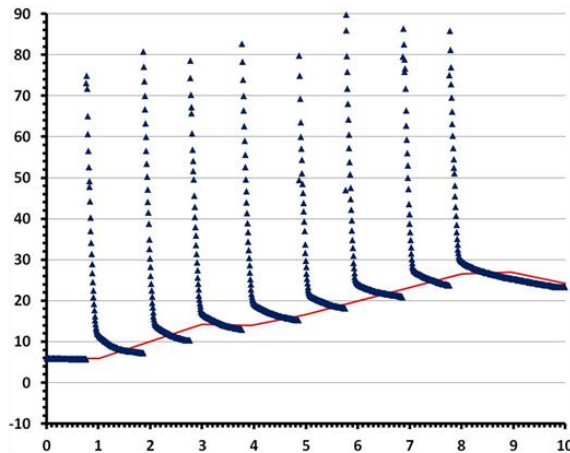

- Impact on charging due to full un-shunting ISS solar arrays when in sunlight – independent of PV array orientation with respect to the velocity vector
- Caused by a set of commands sent to the vehicle, not the natural environment

- Charging occurs in milliseconds, while the relaxation time can be from 0.04 seconds to 0.2 seconds
 - Relaxation time dependent on density. Lower density observed to have longer relaxation times
- Discharging in milliseconds for ISS environment. Charging event duration expected to be much longer in GEO or cis-Lunar environment (no ionosphere).

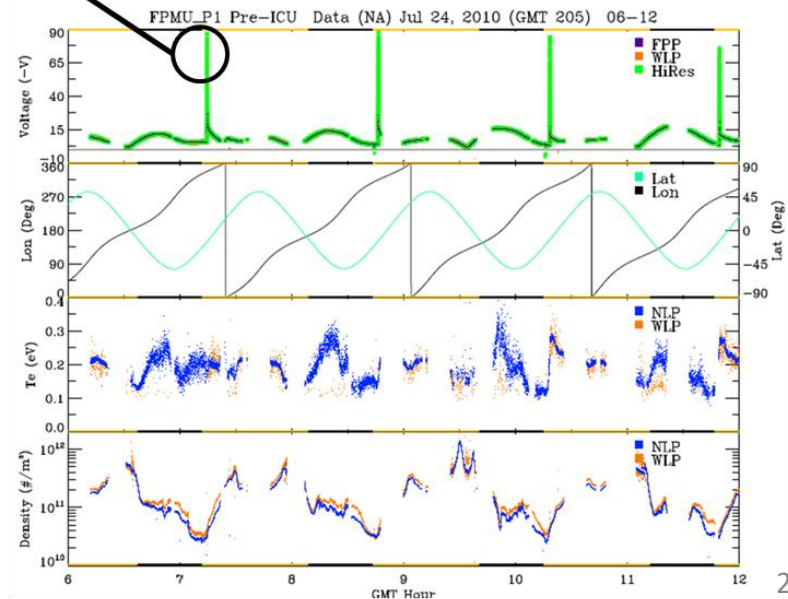



Another Simple, Worked Example: Auroral Charging vs. Capacitance



Effects of Spacecraft Capacitance ($V = Q/C$ and $C = A/d$) on Auroral Charging

Auroral charging current = 2×10^{-5} amps/m² sec ; duration 10 sec.

Case	Capacitance (pF)	Floating Potential, (-Volts)
Sphere – free space (R=1 m)	111.26	30,000 (charging time < 1 second)
Sphere – 10- μ dielectric film	1.26×10^6	2000
Disk – free space (R = 1m)	70.83	30,000 (charging time < 1 second)
Disk – 10- μ dielectric film	3.3×10^5	3806
Estimated International Space Station	1.1×10^{10}	~ 13
Extravehicular Mobility Unit	1.5×10^6	~ 27

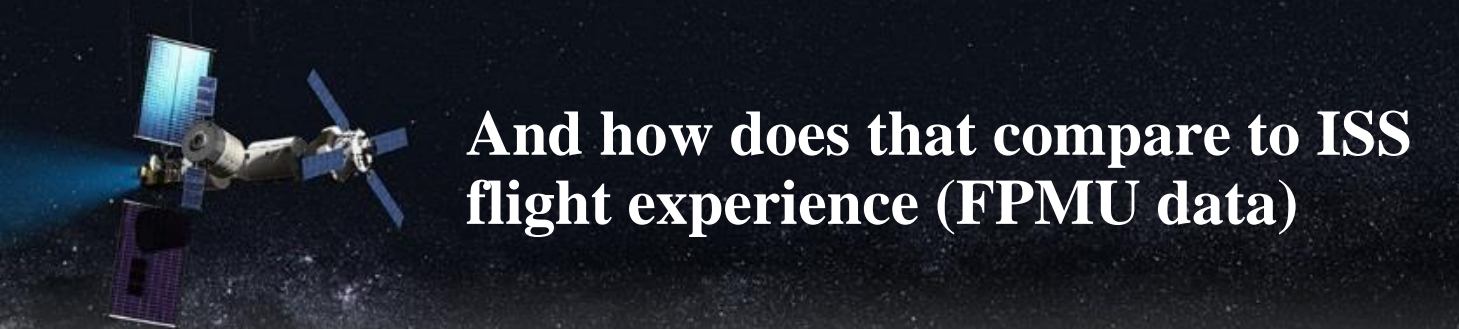

And how does that compare to ISS flight experience (FPMU data)



Auroral charging events have been observed in the FPMU data during eclipse at high latitudes. These events correlate with local electron density (Ne) enhancements caused by the heating and collisional ionization of the plasma.

The ISS was in the auroral zone for 144 seconds; however the times when the FP was rising (i.e., when ISS experienced discrete auroral events) were much shorter (~12 seconds).

-18V observed compares well with the -13V estimate in the worked example table

The strongest observed Aurora FP ISS charging event.

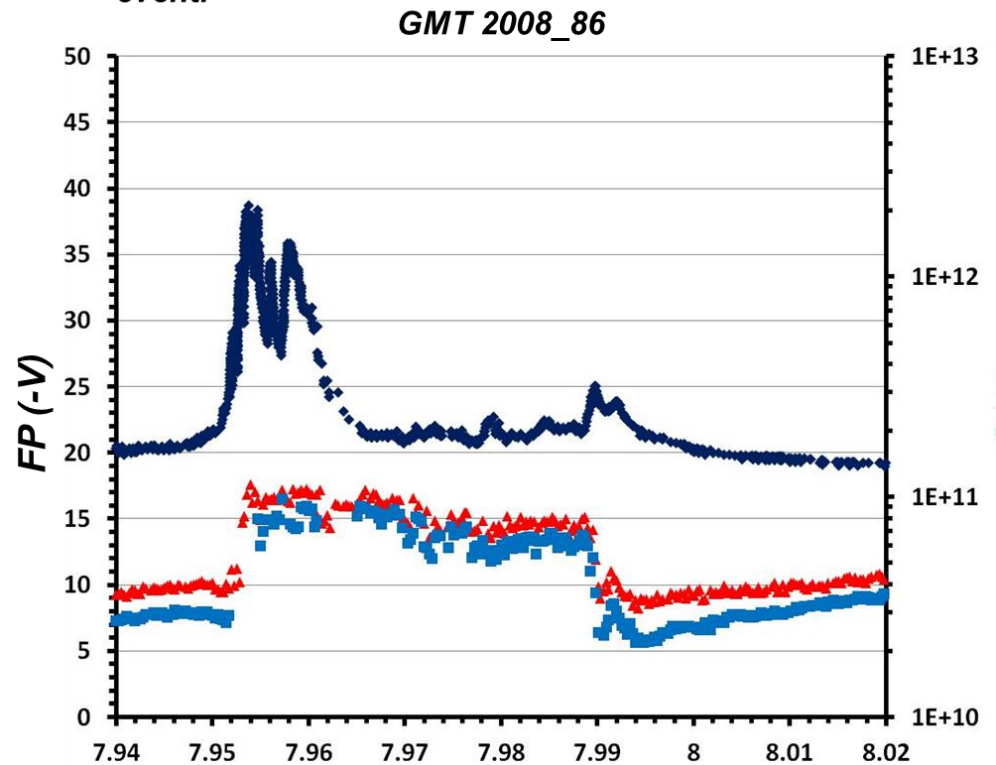

11/19/2015, Boeing Company, Drew Hartman, Leonard Kramer, Randy Olsen: ISS Space Environments SPRT meeting



And how does that compare to ISS flight experience (FPMU+DMSP data)



Defense Meteorological Satellite Program (DMSP) data (GMT 2008_86) show a large frequency of current densities above $2 \times 10^{-5} \text{ A/m}^2$ along the ISS charging event flight path <http://www.ospo.noaa.gov/Operations/DMSP/>

The red line (corresponding to 144 seconds of flight time) displays the ISS trajectory where current densities can exceed $2 \times 10^{-5} \text{ A/m}^2$.

The model of auroral current collection by ISS anodized Al materials (auroral electrons can penetrate 30 micron chromic anodize coatings) is supported by the timelines and magnitudes of DMSP current densities.

Locations of Current Density Exceeding $2 \times 10^{-5} \text{ A/m}^2$

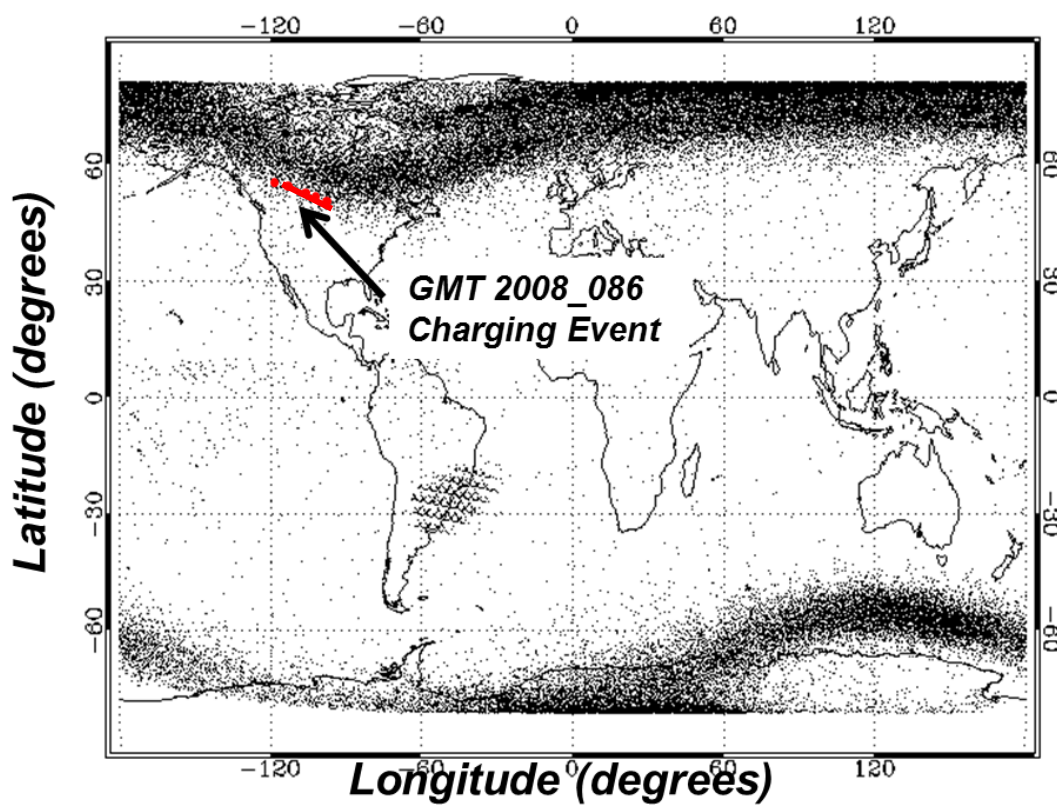

11/19/2015, Boeing Company, Drew Hartman, Leonard Kramer, Randy Olsen; ISS Space Environments SPRT meeting



“Exploration” (Cis-Lunar, Magnetospheric, and Interplanetary) Spacecraft Charging Environments



And where else might we encounter
ionospheric plasmas and magnetic
fields like those in LEO?



- Strong planetary magnetic fields?
 - In the **inner solar system**, only Earth and Mercury have significant magnetic fields
 - The Mercuric field is only about 1% as strong as Earth's
 - The Moon, Mars, Venus, and the near-Earth and main belt asteroids have insignificant global magnetic fields
- Cold, dense, ionospheric plasmas like Earth's?
 - Venus below about 420 km altitude
 - Mars below about 200 km altitude
 - **And one other place you might not immediately expect...**

The other place you might not expect...

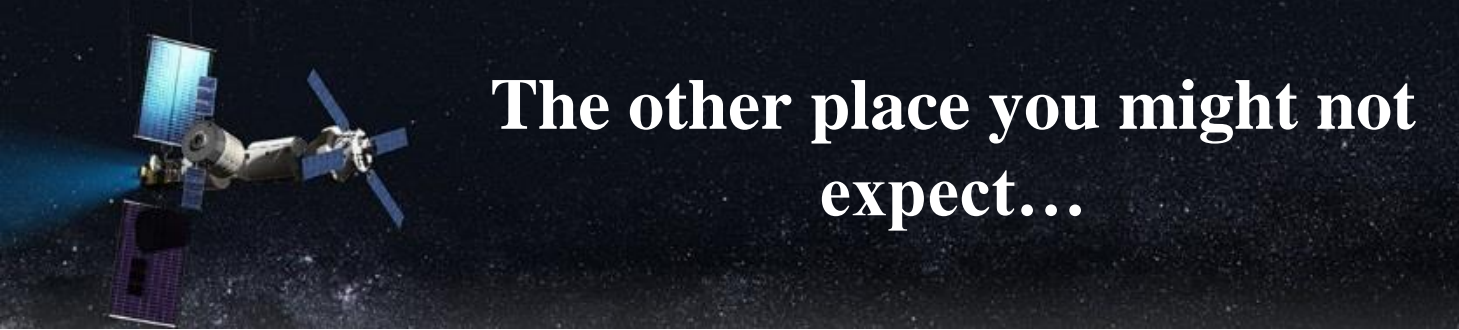

- Surrounding your $> 200+$ kilowatt class, “high” thrust, interplanetary **transport with electric propulsion** whenever the Hall effect, electrostatic, or VASMIR engines are operating
- If EPS is photovoltaic, you can **expect high PV string voltages ($> 160V$)** for efficiency and large PV areas for total power requirement
- **Some risk questions to consider:**
 - How much PV array-driven spacecraft charging can I expect when the electric engines are operating?
 - None if your PCUs are operating
 - **What happens to vehicle floating potential when the high voltage strings are un-shunted?**
 - **What happens if the electric engine neutralizers (e.g, PCUs) degrade or fail?**
 - **Will the PV arrays and power cables be at risk for arc tracking?**
- **Nuclear power reduces risk, but doesn’t eliminate it**
 - thermoelectric power conversion can also lead to high voltage strings exposed to the plasma (NASA SP-100)
(<https://ntrs.nasa.gov/archive/nasa/casi.ntrs.nasa.gov/19890003294.pdf>)



Image credit: ATK Corp.

Ira Katz, Alejandro Lopez Ortega, Dan M. Goebel, Michael J. Sekerak, Richard R. Hofer, Benjamin A. Jorns, John R. Brophy; “EFFECT OF SOLAR ARRAY PLUME INTERACTIONS ON HALL THRUSTER CATHODE COMMON POTENTIALS,” 14 th Spacecraft Charging Technology Conference, ESA/ESTEC, Noordwijk, NL, 04-08 APRIL 2016

Magnetospheric, Cis-Lunar, and Interplanetary Spacecraft Charging Environments

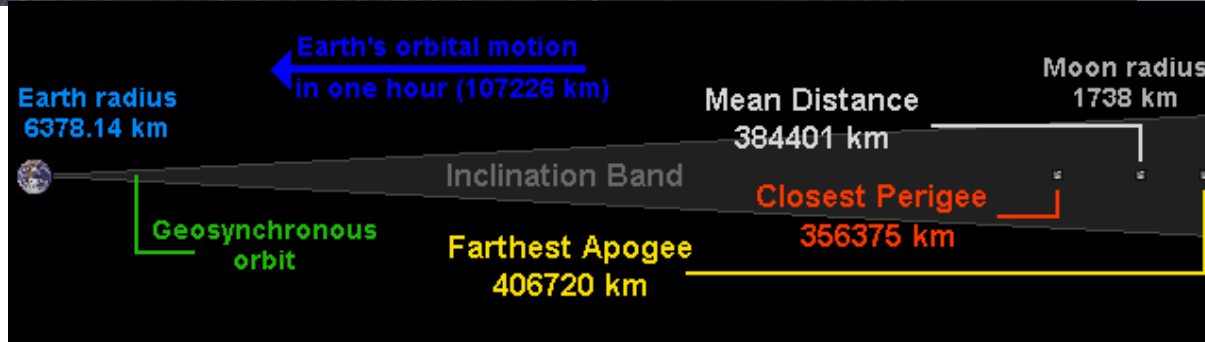

https://www.fourmilab.ch/earthview/moon_ap_per.html

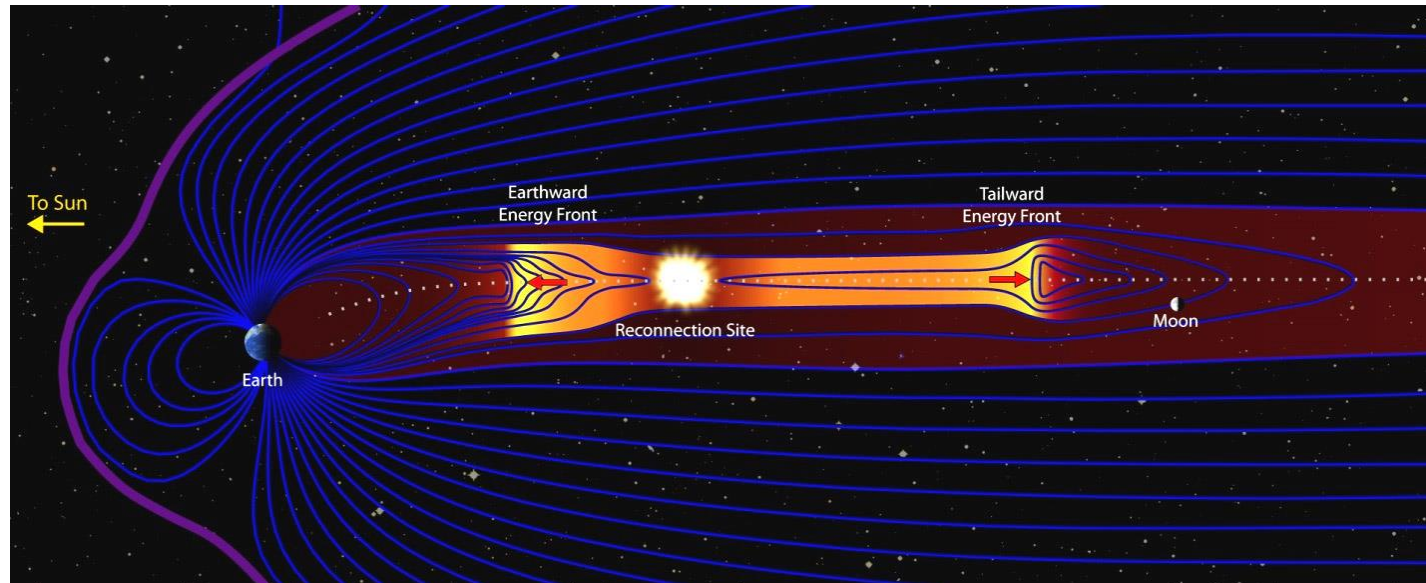

<http://artemis.igpp.ucla.edu/news.shtml>



Magnetospheric, Cis-Lunar, and Interplanetary Spacecraft Charging Environments



- The magnetospheric/GEO/cis-Lunar and NEI natural charging environments are radically different from the ISS LEO charging environments
 - Hot plasmas and energetic charged particles dominate the “Exploration” natural charging environments
 - The SLS/Orion Joint Program Natural Environments Definition for Design Specification, SLS-SPEC-159 REVISION E July 14, 2017 calls out the full range of design environment for missions from LEO to cis-lunar Space
 - **MPCV 70080**, May, 13, 2015, “Cross Program Electromagnetic Environmental Effects (E3) Requirements Document, Section 3.7, Electrostatic Charge Control”, contains specific design requirements for charging hazard mitigation and control, often derived from NASA/DoD standards for GEO/interplanetary spacecraft
 - **Exploration mission timelines/trajectories lead to flight through several different charging environments with different exposure times in each environment**
 - Expected extensive use of electric propulsion creates induced charging environments that will also need assessment and possibly hazard controls
- The neutral current sheet and geotail region of Earth’s magnetosphere are of special importance
 - The Moon is in the geotail/neutral-current-sheet for a few days every month around full moon as viewed from Earth
 - The lunar spacecraft charging environment is comparable to the GEO charging environment during those times as shown by spacecraft measurements
 - The geotail/neutral-current-sheet region can be affected by geomagnetic storms
- Transient space weather events such as Coronal Mass Ejections (CMEs) and Solar Particle Events (SPE) can also pose as yet poorly characterized charging threats to cis-lunar spacecraft



Cis-Lunar Charging Environments: Spacecraft charging measurements in cis-lunar space



- The Moon has no atmosphere capable of blocking solar wind plasma or energetic particles
 - Orbiting spacecraft and the lunar surface are exposed to similar charging threat environments
- **Lunar Orbital/Surface Charging Threat Environments**
 - Earth's magneto-tail (current sheet) hot plasma electrons - A few days on each side of full moon as viewed from Earth
 - Solar Particle Events (energetic electrons and protons)
- **Lunar Prospector cis-lunar Charging Observations - SPE**
 - Lunar surface night-side surface potentials to -4.5 kV
 - Spacecraft potentials to -100 to -300 V
- **Lunar Prospector cis-lunar Charging Observations – Geotail current sheet region**
 - Lunar surface potentials -100 V to -1000 V in sunlight
 - Spacecraft potentials -40 to -80 V
- **Artemis/Themis Charging Observations**
 - Lunar surface potentials -20 V to -600 V, depending on current sheet electron temperature
- **Bottom line for now – cis-lunar environment can be similar to GEO and auroral charging environments, but less severe**
 - The GEO design environment should cover expected conditions
 - However, more charging environment data is needed here



**So what do I do about all this and
what happens if I don't?**



So what do I do about all this?

- What are the spacecraft charging environments for the design reference missions, and does they cover reasonable worst-case conditions?
- How much charging can I expect and when?
- How do I prevent the charging or render it harmless?
 - **Grounding, bonding, and EMI/EMC compatibility**
 - PC board design rules to minimize internal charging/discharging risks
 - Eliminate potentially hazardous EPS/Avionics configurations
 - Can I direct charging/discharging currents around or away from critical, sensitive equipment and astronauts?
 - **Materials selection and static dissipative coatings**
 - Is shielding mass for worst-case energetic electron charging environment possible?
 - Can I select static dissipative or low-charging materials?
 - **Active control during severe charging events (i.e., a PCU or something like it)**
 - **Are there any options for operational hazard controls such as powering down high-voltage systems during extreme charging events?**
- Become familiar with NASA and DoD Standards, Guidelines, and Preferred Practices for managing spacecraft charging
 - **Garrett, H. B., and A. C. Whittlesey. Guide to Mitigating Spacecraft Charging Effects, John Wiley and Sons, Hoboken, New Jersey, 2010**
 - **https://descanso.jpl.nasa.gov/SciTechBook/st_series3_chapter.html**
- See the JPL Voyager spacecraft charging design and verification process - Voyager survived the Jupiter and Saturn fly-by environments only because charging hazards were mitigated by design and verification before flight
 - **A. C. Whittlesey, “Voyager electrostatic Discharge Protection Program,” IEEE International Symposium on EMC, Atlanta Georgia, pp. 377-383, June 1978**

And what happens if I don't? ADEOS – II: Probable auroral charging/discharging event, leading to loss of mission



- **Orbit**
 - Polar - Sun-synchronous
 - Orbit Altitude 802.92km
 - Inclination 98.62 deg
 - Period 101 minutes
- **Failure**
 - On 23 October 2003, the solar electrical power system failed after passing through the auroral zone (high altitude)
 - At 23:49 UTC, the satellite switched to "light load" operation because of an unknown error. This was intended to power down all observation equipment to conserve energy.
 - At 23:55 UTC, communications between the satellite and the ground stations ended, with no further telemetry received.
 - Further attempts to procure telemetry data on 24 October (at 0025 and 0205 UTC) also failed.
- JAXA determined that the total loss of ADEOS-II, a PEO satellite with bus voltage of fifty volt, attributed to interaction between the auroral electron/plasma environment and the improperly grounded MLI around the main EPS wire harness causing a destructive "arc tracking" failure of the wire harness.
- The loss of ADEOS-II investigation revealed that auroral charging of a polar satellite could cause serious failure, including total loss.
- MM/OD impact creating an arc plasma and triggering the main discharge on the power harness is another possibility



- 1) Kawakita, S., Kusawake, H., Takahashi, M. et al., "Investigation of Operational anomaly of ADEOS-II Satellite," Proc. 9th Spacecraft Charging Technology Conf., Tsukuba, Japan, 4-8 April 2005.
- 2) Nakamura, M., "Space Plasma Environment at the ADEOS-II anomaly," Proc. 9th Spacecraft Charging Technology Conf., Tsukuba, Japan, 4-8 April 2005.

And what happens if I don't? ADEOS – II: A more detailed failure analysis

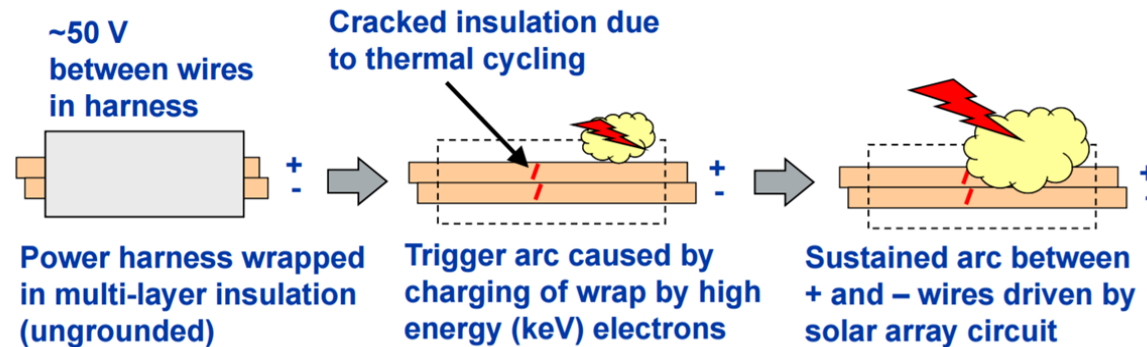

- The power harness configuration itself, with opposite polarity power wires in contact with each other, presents a high arc-tracking risk
- The Tefzel power wire insulation was operating well above its recommended maximum service temperature leading to insulator degradation and cracking
- The satellite passed through the auroral region when the high energy (KeV) electron flux was two orders of magnitude higher than normal, charging the ungrounded MLI blanket and enabling arcing (trigger arc) to the power wires
- Trigger arcs lead to power wire arc tracking and loss of mission
- Note – steady thermal deterioration of the Tefzel insulation would likely have produced this outcome eventually, without help from the auroral charging environment



Summary and Conclusions



Summary and Conclusions

- ISS spacecraft charging processes are dominated by electron collection from Earth's ionosphere
 - Voltage sources driving charging are generated by ISS itself
 - Motional EMF in the geomagnetic field
 - 160V PV power system operations
 - Nominal eclipse exit charging
 - Full PV wing shunt/un-shunt rapid charging peaks (duration depends on ionospheric density)
 - Auroral (energetic charged particle) charging is minimal, largely because ISS vehicle capacitance is so large
 - No evidence to date of auroral charging/arcng on isolated external dielectric materials
- Is ISS spacecraft charging management experience applicable to human rated spacecraft destined for cis-Lunar and interplanetary space? Well, it depends...
 - The magnetospheric/GEO/cis-Lunar and NEI natural charging environments are radically different from the ISS LEO charging environments
 - Energetic charged particles dominate the natural cis-Lunar and NEI spacecraft charging environments
 - GEO/interplanetary spacecraft charging control design and verification processes are recommended in general
 - Using ISS materials and methods without some delta verification to account for the new environment is NOT recommended
 - No natural ionospheric plasma
 - No significant motional EMF
 - However, some specific ISS experience is relevant and applicable
 - Rapid charging peaks from shunt/un-shunt operations on large high voltage/power PV arrays
 - Artificial ionosphere charging effects from high power solar electric propulsion systems
 - ISS EMI/EMC control and verification processes



Back-Up

Spacecraft Surface Charging Environment Risks: Geo-space

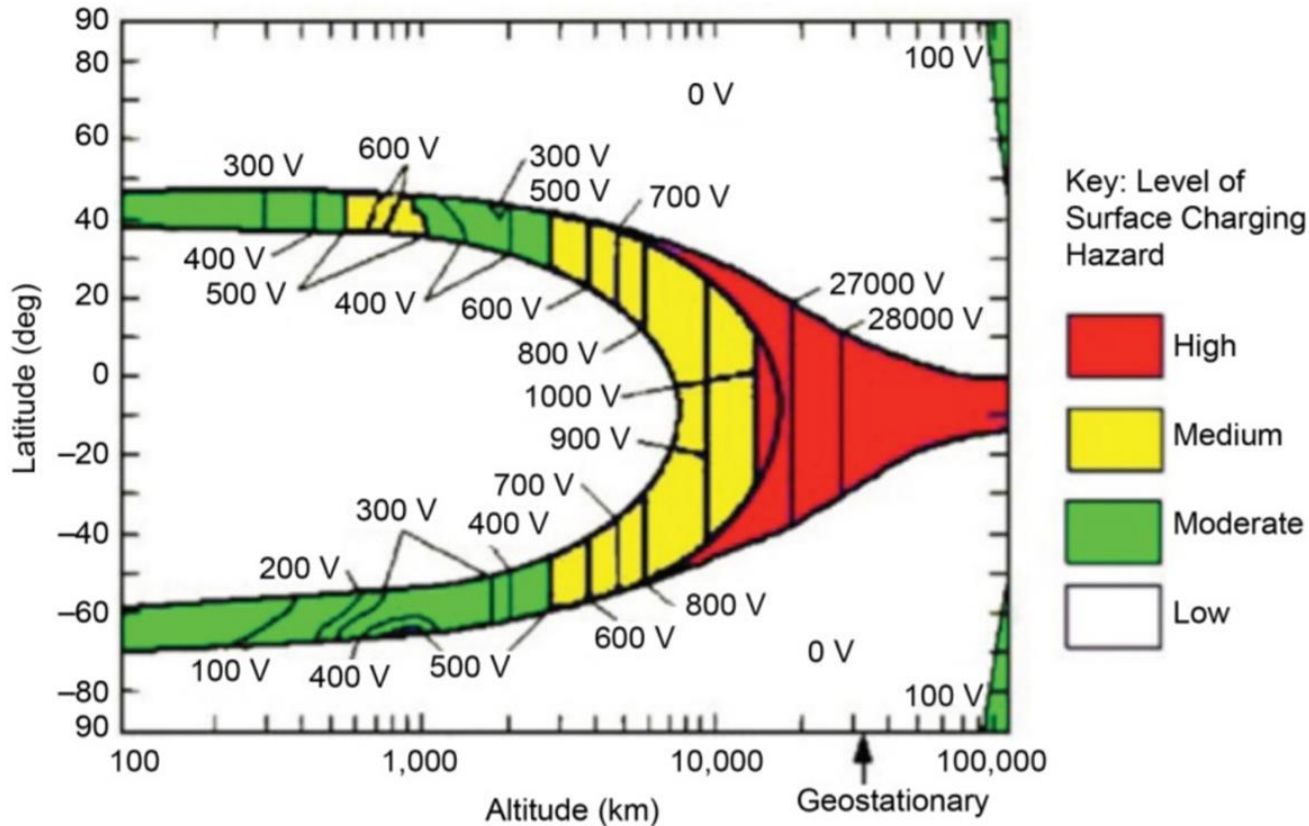

<https://descanso.jpl.nasa.gov/SciTechBook/series3/ChgingBook--110629-RibbonC.pdf>

Garrett, H. B., Whittlesey, A. C.; GUIDE TO MITIGATING SPACECRAFT CHARGING EFFECTS, John Wiley & Sons, Inc., Hoboken, New Jersey, 2012, page 2

Spacecraft Internal Charging Environments Risks: Geo-space

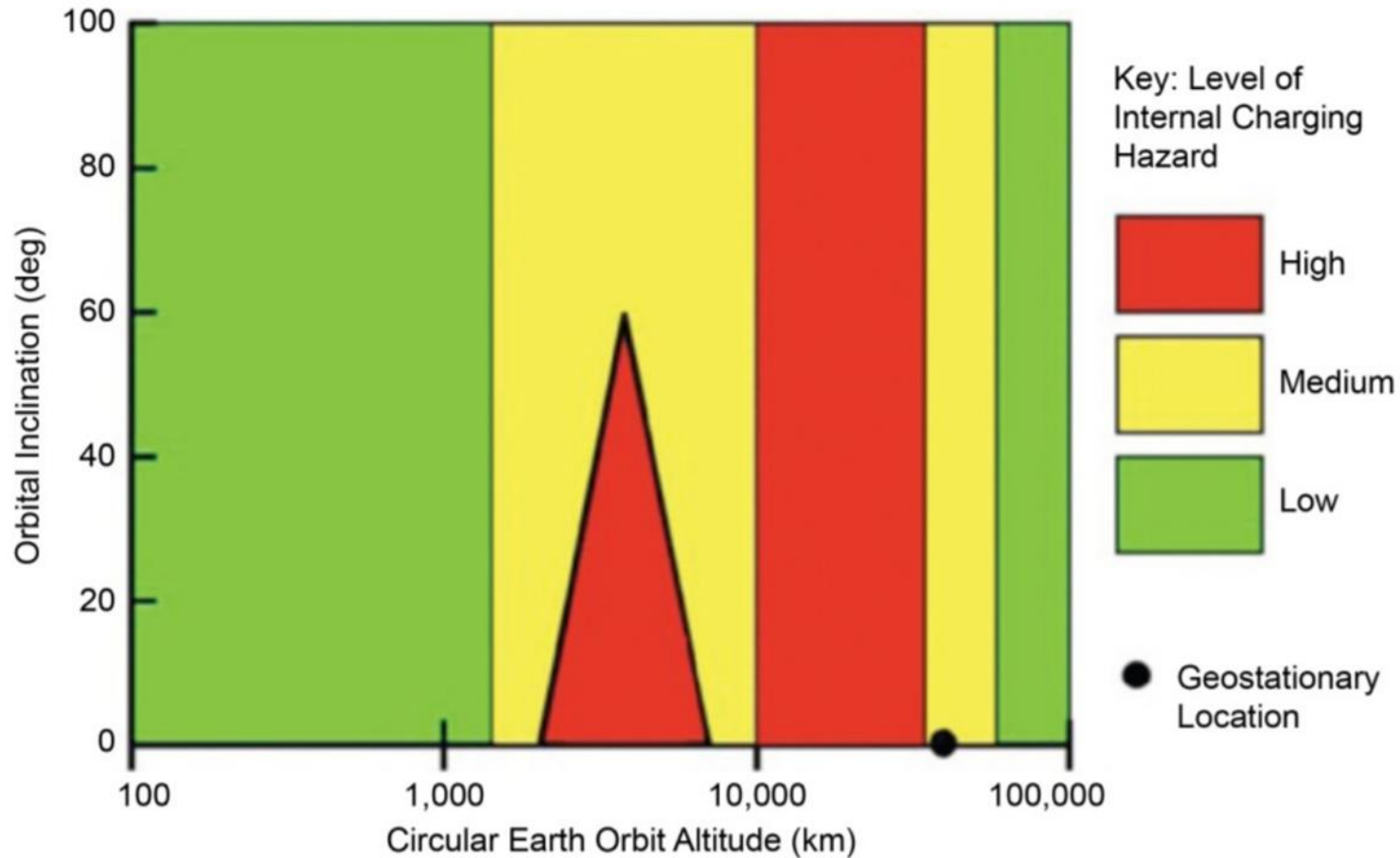

<https://descanso.jpl.nasa.gov/SciTechBook/series3/ChgingBook--110629-RibbonC.pdf>

Garrett, H. B., Whittlesey, A. C.; GUIDE TO MITIGATING SPACECRAFT CHARGING EFFECTS, John Wiley & Sons, Inc., Hoboken, New Jersey, 2012, page 2

ISS Charging Measurements: Floating Potential Measurement Unit - 2006 to 2017



- 4 orbits of FPMU data - PCUs off

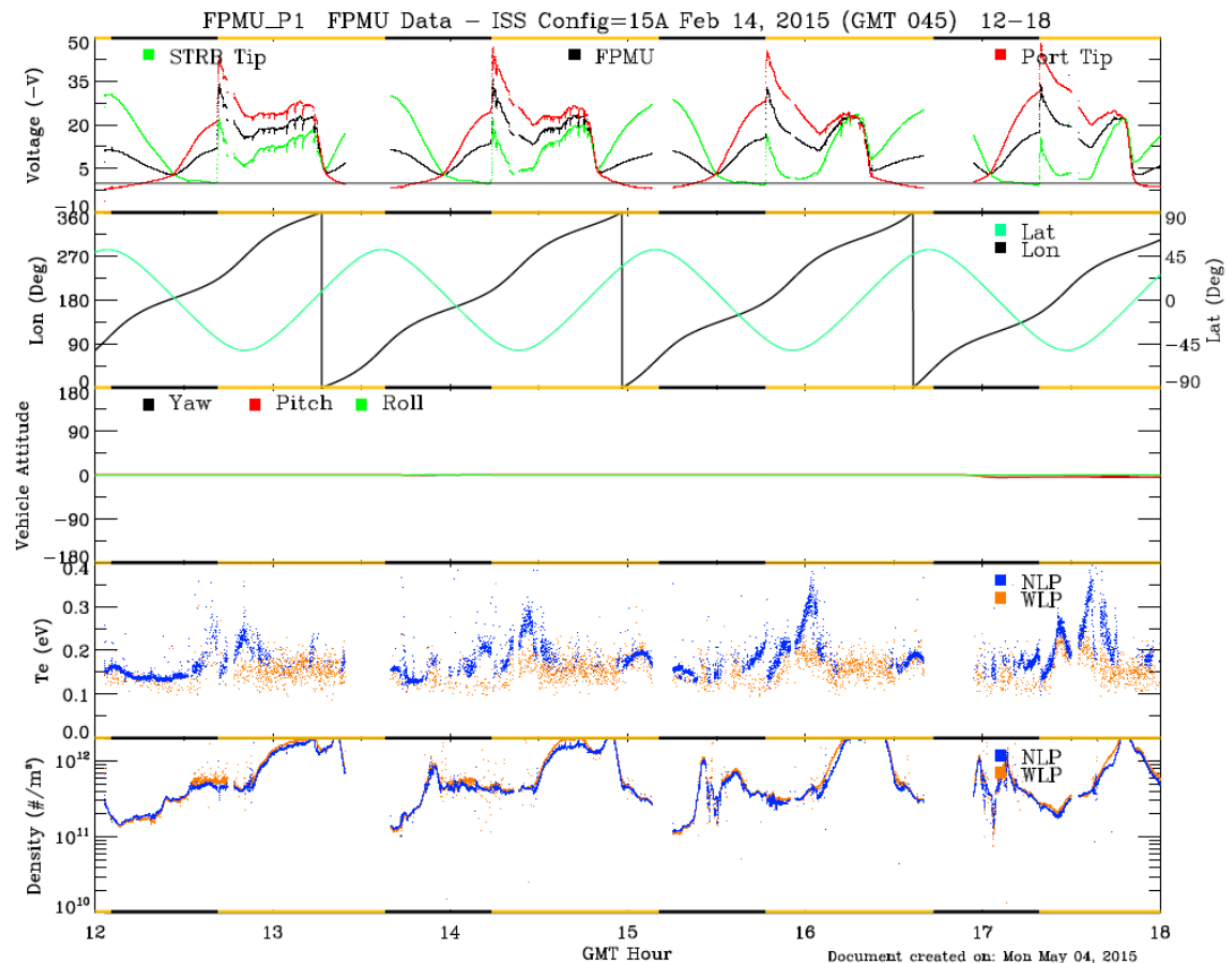

ISS Charging Measurements: Floating Potential Measurement Unit - 2006 to 2017



- 4 orbits of FPMU data - PCUs on

