

# Modal Test of the NASA Mobile Launcher at Kennedy Space Center

Eric C. Stasiunas, Russel A. Parks, Brendan D. Sontag, Dana E. Chandler  
NASA Marshall Space Flight Center  
Huntsville, AL

## ABSTRACT

The NASA Mobile Launcher (ML), located at Kennedy Space Center (KSC), has recently been modified to support the launch of the new NASA Space Launch System (SLS). The ML is a massive structure—consisting of a 345-foot tall tower attached to a two-story base, weighing approximately 10.5 million pounds—that will secure the SLS vehicle as it rolls to the launch pad on a Crawler Transporter, as well as provide a launch platform at the pad. The ML will also provide the boundary condition for an upcoming SLS Integrated Modal Test (IMT). To help correlate the ML math models prior to this modal test, and allow focus to remain on updating SLS vehicle models during the IMT, a ML-only experimental modal test was performed in June 2019. Excitation of the tower and platform was provided by five uniquely-designed test fixtures, each enclosing a hydraulic shaker, capable of exerting thousands of pounds of force into the structure. For modes not that were not sufficiently excited by the test fixture shakers, a specially-designed mobile drop tower provided impact excitation at additional locations of interest. The response of the ML was measured with a total of 361 accelerometers. Following the random vibration, sine sweep vibration, and modal impact testing, frequency response functions were calculated and modes were extracted for three different configurations of the ML in 0 Hz to 12 Hz frequency range. This paper will provide a case study in performing modal tests on large structures by discussing the Mobile Launcher, the test strategy, an overview of the test results, and recommendations for meeting a tight test schedule for a large-scale modal test.

## KEYWORDS

NASA, Large Structures, Experimental Modal Analysis, Hydraulic Shakers, Impact Drop Tower, Multi-Sine Sweep

## INTRODUCTION AND MOTIVATION

The National Aeronautics and Space Administration (NASA) has recently completed modification of the Mobile Launcher (ML), which will provide the launch platform for the new Space Launch System—a new heavy launch vehicle capable of launching both the Orion crew module and massive payloads to the Moon and beyond in a single launch. Before the SLS can receive launch certification, the finite element models of the fully integrated SLS—including the core stage, solid rocket boosters, and mission capsule—must be validated. Therefore, an experimental modal test, officially designated as the Integrated Modal Test (IMT), is scheduled to take place on the fully assembled SLS and will provide the data necessary to perform this model validation. Validated SLS models are critical to NASA, as they provide information for flight dynamic risk assessments, structural load analysis, and even launch control software.

When performing an experimental modal test, particularly one as critical as the SLS IMT, it is important to fully understand the boundary conditions. Unintended interactions between the test item and the boundary constraints during a modal test can strongly influence the modes of interest. If this situation is unavoidable, it is important to understand these influences as it pertains to model verification and correlation. Because the Mobile Launcher will provide the SLS boundary condition during IMT, a Mobile Launcher-only experimental modal analysis test was performed at KSC in June 2019. Validating the finite element model of the Mobile Launcher with the resulting modal test data would define the SLS boundary condition during IMT, and allow the focus to remain on the SLS vehicle as well as increase the confidence of the resulting SLS model.

The Modal Test Team (ET40) from Marshall Flight Space Center (MSFC) in Huntsville, AL, planned and performed the experimental modal test on the Mobile Launcher in the requested frequency range from 0 Hz to 12 Hz. The ML was tested in three different support configurations: supported by six Vehicle Assembly Building (VAB) mount mechanism posts, supported by four Crawler Transporter (CT) posts, and supported by all 10 posts at once. Performing experimental modal analysis on a structure as immense as the ML required the use of uniquely-designed excitation fixtures, many response accelerometers, and various support equipment. This paper will discuss these in detail, as well as provide an overview of the test results and recommendations for future large-scale modal tests.

## **MOBILE LAUNCHER**

The NASA Mobile Launcher, located at Kennedy Space Center (KSC) and originally built for the Constellation program in the mid-2000s, has recently been modified to support the new SLS program. This immense structure consists of a two story, 25-foot tall base platform attached to a 355-ft tall tower for a total height of 380-ft and combined weight of approximately 10.5 million pounds. The base measures 165-ft long by 135-ft wide, and the tower measures 40-ft square. Normally, the base sits 22-feet off the ground, supported by six steel support posts that connect to support structures inside the Vehicle Assembly Building, as well as at the launch pad. The complete as-tested ML structure is shown in Figure 1, secured to the Crawler Transporter during rollout to the launch pad. The VAB can be seen behind and to the right of the ML.

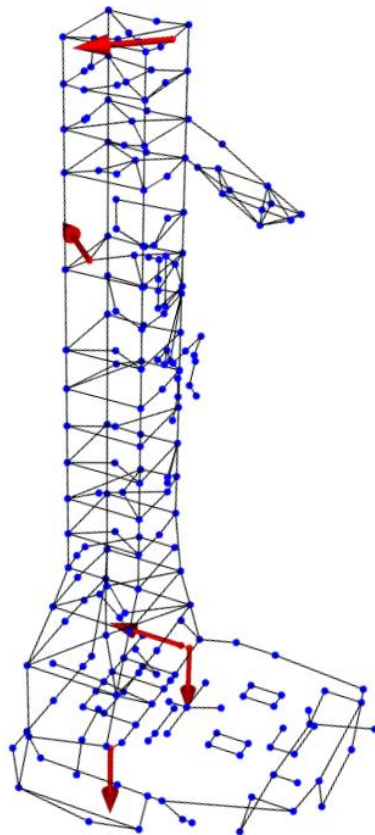


**Figure 1: Mobile Launcher [1]**

The Mobile Launcher serves many functions in regards to the Space Launch System. During the SLS assembly process, the ML provides structural support and provides access to service the assembled vehicle. When ready for launch, the SLS and ML will be secured to the CT and moved from the VAB to Launch Pad 9, as seen in Figure 1. At the launch pad, the ML provides power, communications, coolant, and fuel through umbilicals that reach from the ML tower to the SLS. Finally, the crew access arm (CAA) that provides a walkway for astronauts to access the Orion crew capsule is located at the 274-foot level of the ML tower. The umbilicals and the CAA all retract prior to, or during, lift-off [2, 3].

## MODAL INSTRUMENTATION

Extensive pre-test analysis was performed on the Mobile Launcher analytical model by the Dynamic Test and Modal Sensitivity Study Team at MSFC in order to determine the most effective excitation and response measurement locations to capture a set of target modes. Additionally, the measurement degrees of freedom defined by the pretest analysis were selected to minimize the off-diagonal terms of the test cross orthogonality matrix of the measured target modes. Five locations were selected for the modal excitation: two in the vertical direction and one in the lateral (horizontal) direction on the ML 0-deck, one in the lateral direction at the 245-ft level (mid-tower), and one in the lateral directions at the 345-ft level (top of tower). For the response measurements, 235 locations were selected with a total of 361 degree-of-freedom (DOFs). Note the resulting measurement set did not measure 3 degrees of freedom at every selected measurement node.



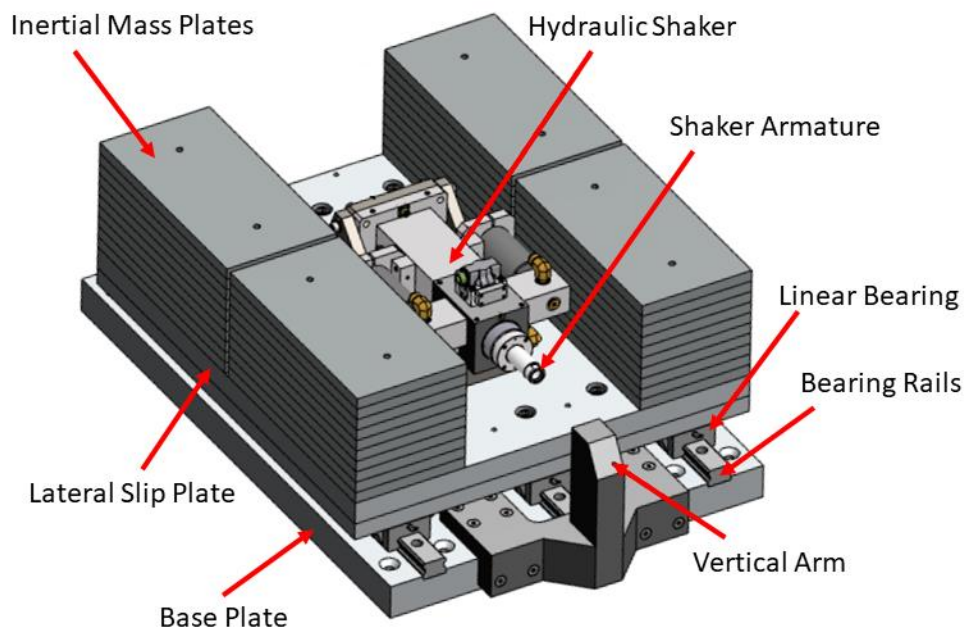
**Figure 2: Modal Test Geometry (red = input, blue = response)**

The modal test geometry of the Mobile Launcher with the measurement locations, as determined by the pre-test analysis, is shown in Figure 2. The five excitation locations are indicated by the red nodes at the base of the red arrows, which point in the direction of excitation. The 235 response locations are indicated by the blue nodes (DOFs not shown). Note that in addition to the ML tower and base, the umbilicals (nodes hanging off mid-point tower) and crew access arm (beam hanging off near the top of the tower) were of interest as well, as they exhibited local modes relative to the tower within the desired frequency range.

## MODAL EXCITATION – SHAKER TEST FIXTURES

Modal shaker tests are typically performed by exciting a test item with a shaker, while the shaker is either attached to, or suspended from, a rigid separate structure. Due to the immense size and weight of the Mobile Launcher, as well as a lack of available support structures for proper shaker mounting, an alternate shaker input method was required for the ML. For these reasons, five test fixtures were designed—each enclosing a hydraulic shaker that oscillated inertial masses on slip bearings—to provide adequate modal excitation into the Mobile Launcher. In order to excite the ML in all three axes, both lateral (horizontal) and vertical shaker test fixtures were built.

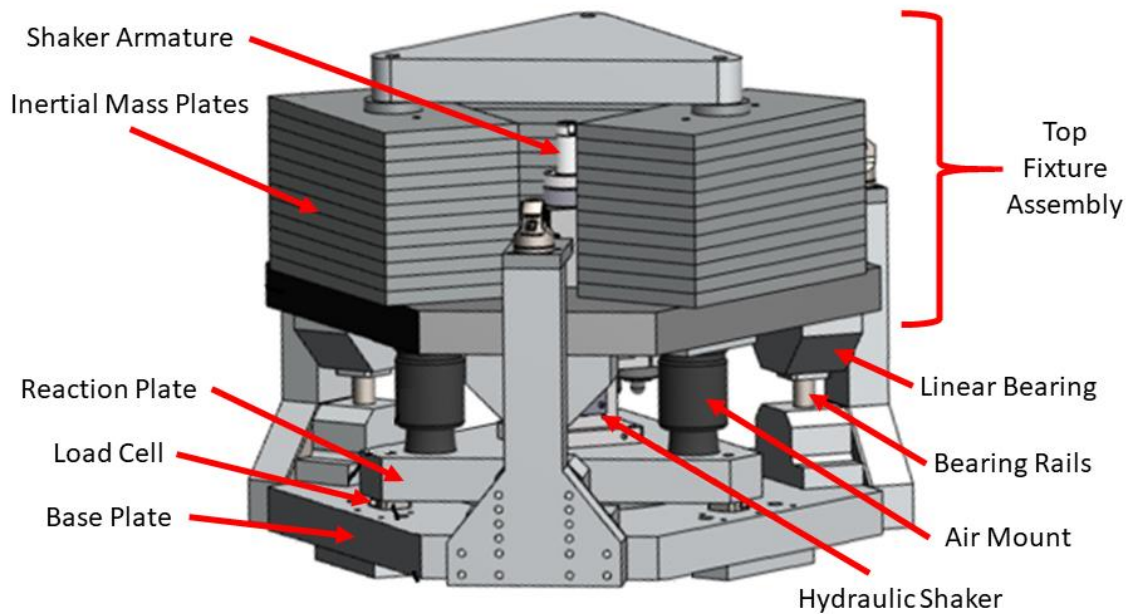
The lateral shaker test fixture consisted of a hydraulic shaker and 2100-lbs of inertial mass plates attached to the top side of a slip plate. On the bottom side of the slip plate were linear bearing assemblies that rode on horizontal rails attached to a base plate that was bolted to the ML structure. The shaker armature was attached to a vertical arm on the base plate. Excitation forces were generated by oscillating the shaker and slip plate assembly relative to the vertical arm, for a total moving mass of 2867-lbs. Forces were measured with a PCB model 1381-01A rod-end load cell that was installed between the shaker armature and the vertical arm. A labeled drawing of the horizontal shaker test fixture, without the load cell, is shown in Figure 3.



**Figure 3: Lateral Shaker Test Fixture**

The vertical shaker test fixture was similar to the lateral shaker test fixture in that it oscillated an inertial mass to produce an input force. However, in this case, the hydraulic shaker was positioned vertically and was attached to a reaction plate that was bolted to a base plate, with three PCB Model 202B ring-type load cell washers installed at the interface to measure the force. The hydraulic shaker armature drove into a top fixture assembly, guided by linear rails and bearings, which carried 2000-lbs of inertial mass plates, for a total moving mass of 2273-lbs. Three pneumatically pressurized air mounts supported the sliding top fixture, while providing the sufficient dynamic displacement. A labeled drawing of the vertical shaker test fixture is shown in Figure 4.

The rod-end and ring-type load cells installed in both shaker test fixtures provided the force measurements required for calculating driving point frequency response functions (FRFs). While only a single force was measured for the lateral fixture, three forces were measured for the vertical fixture—the sum of which equaled the input force into the ML structure. In order to provide force data for real-time FRF calculations, the three individual forces were summed using a Stanford Research System model SIM980 voltage-summing box and output to the data acquisition system. The individual forces were recorded as well, which allowed for post-test summation and processing of the total vertical force if desired.



**Figure 4: Vertical Shaker Test Fixture**

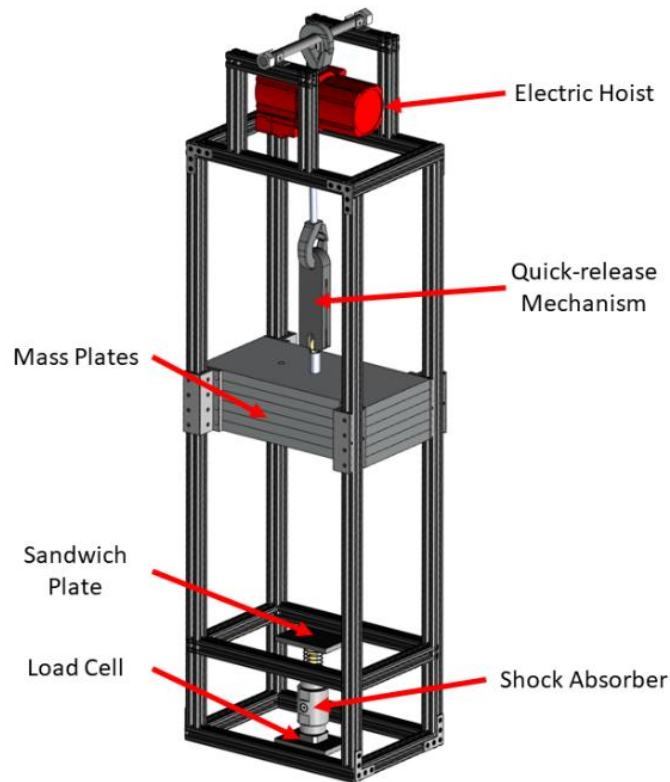
The hydraulic shakers used in the test fixtures were TEAM Model 24/0.8 shakers, selected primarily for their low frequency excitation capability from 0 Hz to 400 Hz, which included the ML modal test frequency range of interest. Additionally, with the rated 4-inch peak-to-peak armature displacement and the moving masses, these hydraulic shakers also provided sufficient force excitation down to very low frequencies (around 0.5 Hz). When powered by the TEAM model HPS-10A hydraulic pump operating at 3000 psi, the dynamic force rating of the shaker was 1560-lbf, which provided sufficient force excitation at the higher frequencies of interest.

It is worthwhile to note that hydraulic shakers pose logistical challenges when compared to typical modal electrodynamic shakers, as they require hydraulic pumps, supply lines, hydraulic fluid, and spill containment measures. They also suffer from input harmonic distortions when exciting frequencies well below the hydraulic column frequency. However, hydraulic shakers have proved to be worth the effort due to their high force output, large peak-to-peak displacement, and low frequency limits down to 0 Hz. Comparatively, typical electrodynamic shakers have less force output, higher low frequency limits (around 5 Hz), and displacements no more than 2-in peak-to-peak at most, severely limiting low frequency excitation.

## **MODAL EXCITATION – IMPACT DROP TOWER**

Even though the pre-test analysis determined the effective shaker locations for the ML modal test, there was no guarantee that the shaker input would be sufficient to excite all the modes of interest, particularly vertical modes of the base platform. Therefore, a vertical, portable impact drop tower with removable wheels was designed and built that could be moved to any accessible node on the top floor of the base platform (0-Deck), and excite the structure with more force than obtainable with a typical impact hammer modal sledge. A labeled schematic of the impact drop tower, with the wheels removed, is shown in Figure 5.

The impact drop tower, constructed out of 8020 T-Slot aluminum, was operated by raising a 400-lbf stack of mass plates to a prescribed height—depending on the force needed—with an electric hoist located on the top of the tower. The mass plates were constrained by slip bearings on the tower frame. A quick-release mechanism would then release and drop the sliding mass plates onto a sandwich plate attached to a shock absorber. The shock absorber was purposefully selected to provide an impulse broad enough to excite up to 20 Hz (with 20 dB roll-off). The input force was measured with a ring-type PCB Model 206M06 load cell, installed between the base of the shock absorber and the base plate.



**Figure 5: Impact Drop Tower**

## **MODAL RESPONSE – ACCELEROMETERS**

As with the hydraulic shaker selection, the accelerometer selection for the Mobile Launcher modal test was driven by the low frequency test requirements. For accurately measuring at frequencies below 1.5 Hz, PCB Model 393B04 accelerometers were selected due to their high sensitivity of 1000 mV/g, low frequency measurement range of 0.06 Hz to 450 Hz, and their low noise-floor characteristics. Because there were not enough 393B04 accelerometers for all the requested measurement locations on the ML, 181 of these accelerometers were installed at locations that participated heavily in the first few modes of the structure. Endevco 46A16 accelerometers, with a nominal sensitivity of 100 mV/g and frequency range of 1 Hz to 10000 Hz, were used for the remaining measurement locations on the ML.

Both accelerometer models were stud-mounted to an accelerometer block manufactured by MSFC, and adhered to the ML at the node locations (blue dots) of Figure 2. The KSC instrumentation group performed the instrumentation work and used HBM-X60 dental cement on aluminum tape to apply the accelerometer blocks. Signal conditioning of both accelerometer models was provided by the B&K data acquisition hardware, which provided Constant Current Line Drive (CCLD) power with high-pass filtering set to 0.1 Hz. The high pass filtering setting removed DC offsets while allowing for accurate measurements, particularly with the low-frequency PCB 393B04 accelerometers.

For past large-structure tests, such as the B2 Stand Modal Test [4], the MSFC Modal Test Team used capacitive-type accelerometers to measure low frequency response. However, these accelerometers were powered with an external signal conditioner that required manually zeroing out the DC offset due to gravity and DC drift prior to every test, which both complicated the test setup and extended the test time depending on the number of the capacitive-type accelerometers used. Despite attempts to minimize DC offset, the data would most often exhibit undesired amounts of DC drift that would typically require high-pass filtering. Therefore, low-frequency CCLD, or IEPE (integrated electronics piezo-electric), accelerometers were selected for the ML test, and have been proven easier to setup, operate reliably, and provide accurate response measurements of large structures in the low frequency regime.

## TEST CONTROL CENTER

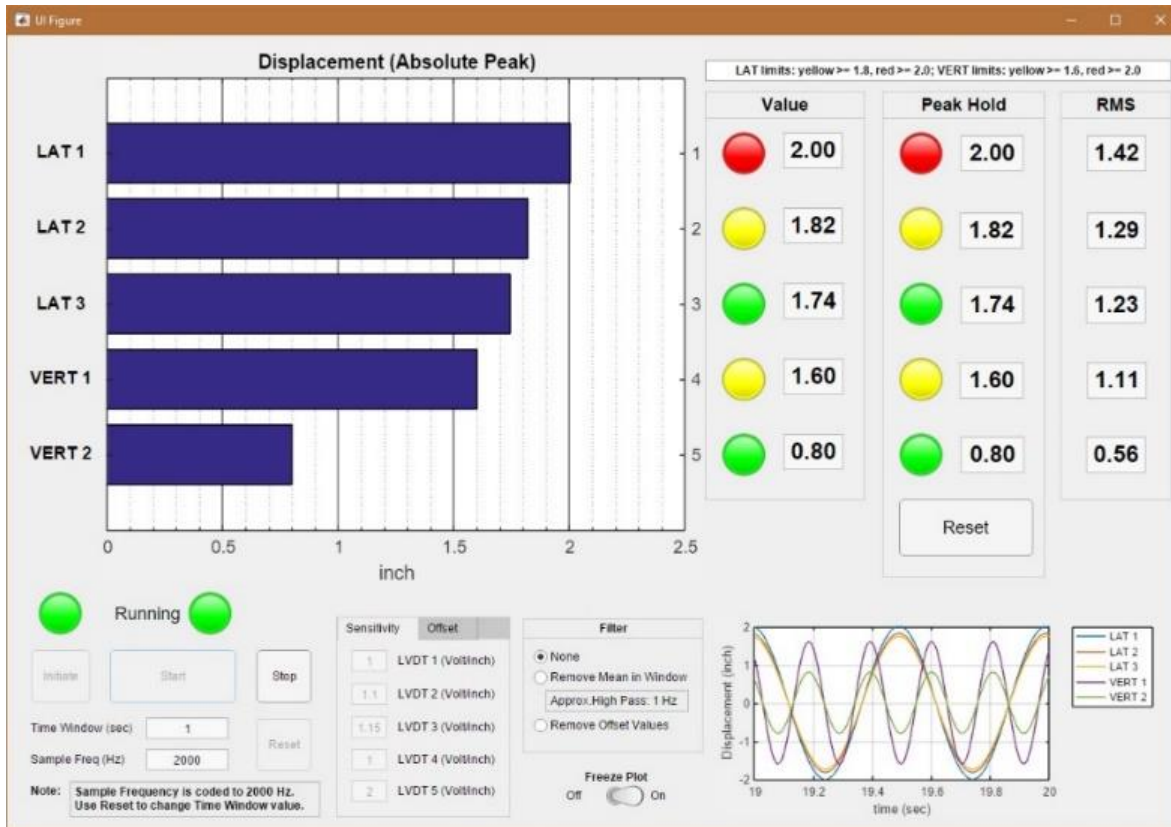
The modal test control center, consisting of the data acquisition system (DAQ) and remote shaker monitoring systems, was located on the second floor, inside the Mobile Launcher base. This location was out of the way from the various SLS/ML support activities, protected from the elements, and provided enough power to operate the test equipment. Additionally, this area of the ML interior was air-conditioned for a majority of the testing, which was appreciated greatly by the test engineers. With the space available inside the ML, the test control center was arranged as seen Figure 6. The DAQ hardware is seen on the left side of the figure, and the shaker monitor systems—which included a displacement monitoring system, a video surveillance system, and multiple oscilloscopes used to display the input force signals—are seen on the right of the figure.



**Figure 6: Test Control Center (DAQ and Shaker Monitoring System)**

The data acquisition system used to record the 384 channels of data—including force, acceleration, displacement, and drive voltages—consisted of Bruel and Kjaer (B&K) LAN-XI front-end modules operated by BK Connect software, running on a Windows-based HP Z820 PC computer. The LAN-XI modules were distributed into three 19-inch racks holding two B&K mainframes each, and placed along the height of the ML tower. All transducers were connected to the mainframes at these locations via RG-174 co-axial cables. Ethernet cables of various lengths (6-ft to 300-ft) connected the mainframes to the DAQ PC via an Ethernet hub. A single 19-inch rack containing two B&K mainframes with 22 LAN-XI modules are shown with the Ethernet hub on the left side of Figure 6; the PC (with a very, very large monitor) running the BK Connect software can be seen in the center of the figure.

The shaker displacement monitoring system provided an efficient view of all five shaker displacements in addition to maximum armature stroke limit warnings and alarm indicators. A MATLAB executable running on a portable PC was used to operate an NI cDAQ-9174 chassis with two 4-channel NI-9239 input cards, which measured the built-in linear variable differential transformer (LVDT) signal from each hydraulic shaker; these signals were recorded by the DAQ as well. The MATLAB graphical user interface, shown in Figure 7, allowed for adjustable measurement sample rates, LVDT sensitivity values, and peak hold values. Furthermore, the interface made it easier for the DAQ engineer to immediately detect displacement limit exceedances and decrease the hydraulic shaker gains as required to prevent banging of the fixture stops.



**Figure 7: Hydraulic Shaker Displacement Monitor Interface**

The video surveillance system provided a real-time view of all five shaker test fixtures from the test control center. At each shaker location, an analog color camera was arranged on a tripod with a full-field view of each shaker test fixture (the adjacent 0-deck lateral and vertical fixtures were in the frame of a single camera). The camera signals were connected to a 16-channel video multiplexer via BNC co-axial cable, which displayed all fixtures on a large monitor simultaneously. The multiplexer also recorded the video signals, providing test documentation as well as a record of any test fixture malfunctions that were to occur during testing (note: no drastic test fixture malfunctions occurred during the ML modal test).

The final component of the shaker monitoring system consisted of three 4-channel TDS1064 Tektronix oscilloscopes, installed in a 19-inch rack that provided a visual display of the shaker force input voltages. Viewing the raw force waveform was particularly useful if problematic force levels were detected on the DAQ during testing. As was discovered with the 0-Deck lateral shaker, being able to zoom in on the force signals helps immensely in diagnosing equipment issues. Additionally, the oscilloscopes provided RMS calculations, which was useful for adjusting hydraulic shaker gains on test startup. Altogether, these shaker monitoring systems proved to be very useful, as they provided immediate feedback to the DAQ engineer during shaker startup and testing, preventing possible damage to the test structure, shaker, or personnel.

## TEST PLAN AND DATA ACQUISITION PARAMETERS

Based on a combination of pre-test analysis and dry runs performed with the hydraulic test fixtures in the lab at MSFC, it was determined that the requested test frequency bandwidth of 0 Hz to 12 Hz would be split into two smaller bandwidths for the random vibration modal tests. Driving the shakers with the smaller bandwidth random signals from the DAQ sources resulted in obtaining higher force levels. Therefore, a low frequency random test from 0 Hz to 3 Hz, and a high frequency random test from 3 Hz to 12 Hz would be performed with all five shaker test fixtures running simultaneously (multi-shaker) with



uncorrelated output. This was particularly important for the low frequency bandwidth, where it was desired to provide as much drive force near 0 Hz as possible, in order to excite the first few modes of the ML.

A fine frequency resolution was required for the multi-shaker random vibration modal testing due to the low response frequencies of interest. Therefore, a time window (T) of 256 seconds, with a corresponding frequency resolution ( $\Delta f$ ) of 0.0039 Hz, was selected to calculate the frequency domain functions from the random vibration time data. To average out the non-biased noise in the spectral analysis calculations, 62 averages were measured with a Hanning broad window and 66.6% overlap, resulting in a total test time of approximately 92 minutes for each of the two frequency bandwidths (0 Hz to 3 Hz and 3 Hz to 12 Hz). These random vibration modal signal-processing parameters were proven sufficient from additional dry runs performed with the horizontal hydraulic test fixture on the historic 363-ft tall Saturn V Dynamic Test Stand, located at MSFC.

In addition to the multi-shaker random vibration modal testing, plans were made to perform a multi-shaker sine (or multi-sine) sweep test if deemed necessary at test time. A multi-sine sweep test is defined as exciting a test structure with multiple shakers simultaneously, each outputting an uncorrelated sine sweep signal over the same frequency range. This test method is known for saving tremendous amounts of test time, as each shaker does not have to run a sine sweep individually. For the wrapped multi-sine method, each shaker starts at a different frequency within the sweep range, and once the shaker gets to the end of the frequency range, it ramps down, then ramps up to the beginning of the frequency range. Further detail of multi-shaker sine sweep testing can be found in [5,6].

Based on the results from the multi-shaker random test, a wrapped, multi-sine sweep signal for up to four of the hydraulic shakers could be created with an ATA-MATLAB code over a desired frequency range and with a given sweep rate. The multi-sine sweep signals would then be loaded into MATLAB and output as voltages from a 4-channel NI-9269 voltage output module, located in a NI cDAQ-9171 single-card chassis. The output voltages would be run directly into the hydraulic shaker inputs, disconnected from the DAQ outputs at the test control center, resulting in an open-loop, multi-sine sweep test.

The final type of test planned for the ML was modal impact excitation, provided by the portable impact drop tower. Any locations on the ML 0-Deck that were not excited by the shaker test fixtures could be impacted by the drop tower and analyzed for modal frequencies. This test would provide verification that no global modes were missed during the random and multi-sine testing, particularly the vertical modes of the 0-Deck.

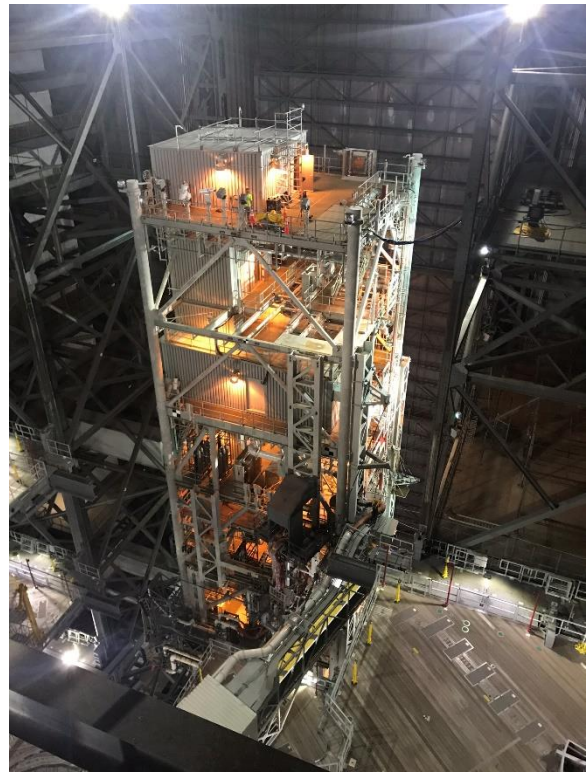
Time histories were recorded by the BK Connect DAQ with the global sample rate of 512 Hz, resulting in a time resolution ( $\Delta t$ ) of 0.00195 seconds for all modal test excitation methods (multi-shaker random, the multi-sine testing, and the impact tower). Real-time signal processing was performed by BK Connect during each modal test as well. The time histories allowed for the additional post-test processing by the modal teams with whatever method they deemed best for the test data.

## TEST CONFIGURATION

The Mobile Launcher modal testing was performed inside the KSC Vehicle Assembly Building from June 16 to June 24, 2019. Testing was performed at night, once all SLS/ML support work had ceased for the day, to minimize the amount of unmeasured noise into the modal measurements. Additionally, the high-bay doors of the VAB were closed during testing to prevent any wind from exciting the tower with unmeasured wind force. Two views of the ML during a night of modal testing are shown in Figure 8—the tower as viewed from the 0-deck on the left, and the top of the tower as viewed from the VAB on the right. As seen in the photos, the VAB platforms used to service the SLS have been retracted from the ML. On the lower half of the tower, the grey umbilicals can be seen retracted to the tower, and the crew access arm is somewhat visible extending from the top half of the tower (a portion of the white roof at the end of the arm can be seen at the bottom of the right photo).



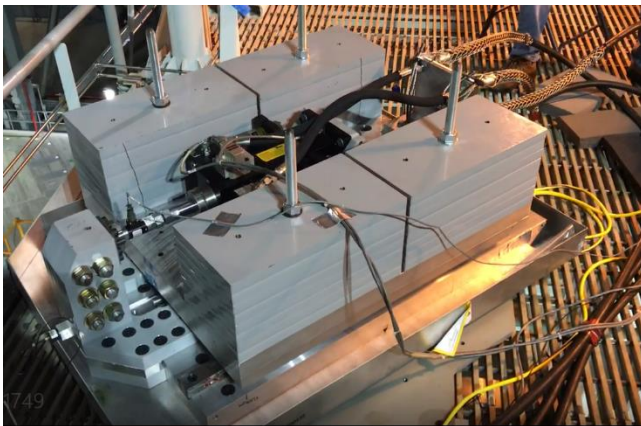
(a)



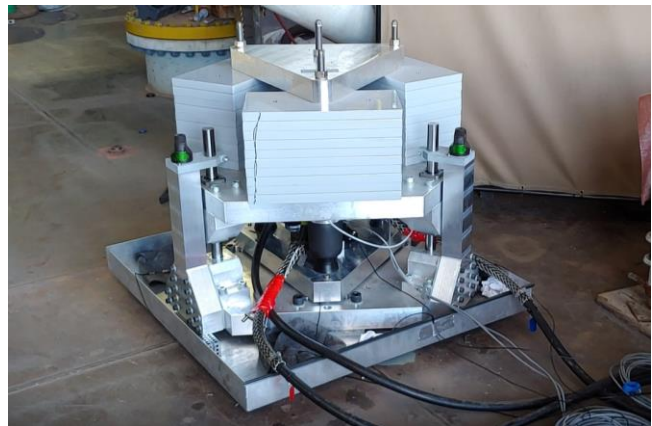
(b)

**Figure 8: Mobile Launcher Test Configuration (a) view from 0-Deck and (b) view from VAB**

The hydraulic shaker test fixtures were installed weeks prior to the modal test and operated locally, at very low levels, to determine proper assembly and operation. The hydraulic hoses from the shakers were run to their corresponding hydraulic pumps, which were all located on VAB platforms. Placing the pumps on the VAB eliminated the possibility of pump noise contaminating the modal data. Two of the operational shaker test fixtures are shown in Figure 9. In the lateral shaker test fixture, the rod-end load cell can be seen installed between the shaker armature and the vertical arm. Also seen in the figure is the foam padding placed under the hydraulic hose to both reduce any undesired hose vibration into the ML platform as well as reduce friction between the hose and the fiberglass platform. Note that both shakers were installed with hydraulic fluid spill containment pans located between the shaker and the ML structure.



(a)



(b)

**Figure 9: Installed Hydraulic Shaker Test Fixtures, (a) Lateral and (b) Vertical**

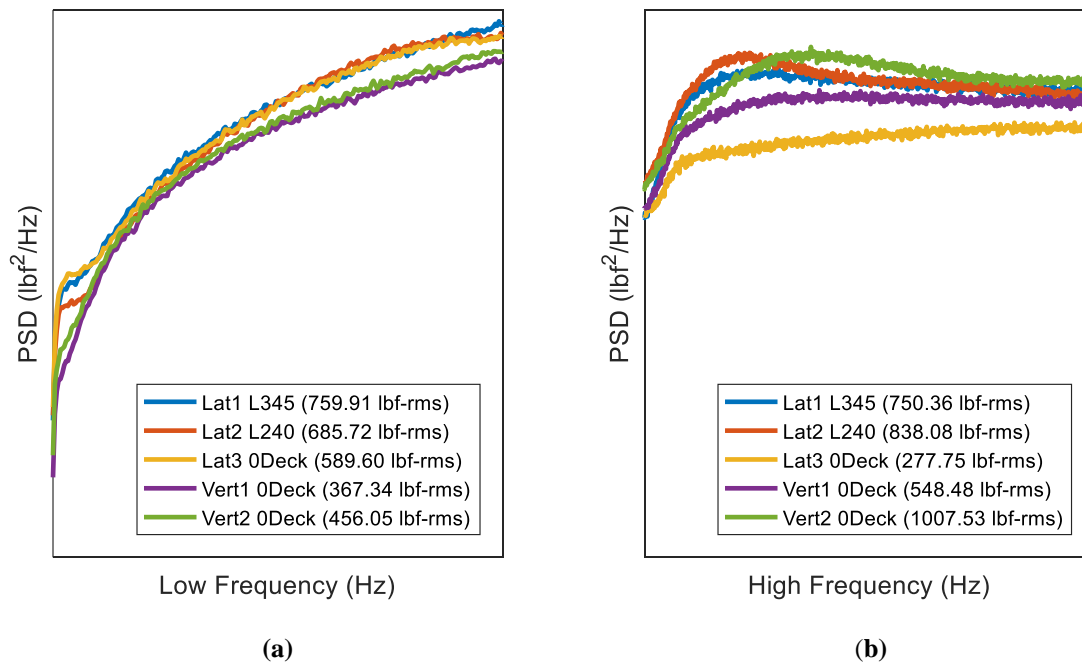
## TEST RESULTS

Ultimately, all three types of modal tests—multi-shaker random, multi-shaker sine sweep, and impact tower—were successfully performed on the Mobile Launcher in all three mount configurations, and completed ahead of schedule. The multi-shaker random modal testing provided sufficient excitation of the ML in the two frequency ranges (0 Hz to 3 Hz and 3 Hz to 12 Hz) to identify and extract the modal parameters of interest. Multi-shaker sine sweep testing was performed from 12 Hz to 3 Hz with the three shakers on the 0-deck to verify the random modal results. Finally, impact drop tower testing was performed at a few select accelerometer locations on the Mobile Launcher 0-Deck.

The only major equipment problem experienced during the modal testing was with the 0-Deck lateral shaker test fixture, which began to decrease in force output following the first night of testing. Post-test investigation conducted at MSFC indicated that the shaker was misaligned with the vertical post, which increased bearing friction, and therefore decreased the available force output. This decreased force was first detected in the data measured during the first ML test configuration. The 0-Deck lateral shaker was determined ineffective during the second ML test configuration and was not used for the remainder of the testing. The subsequent data that will be discussed in this section was measured with the ML in the first configuration, so it will include data from this shaker test fixture.

The results in this section will cover only the first Mobile Launcher test configuration, supported by the VAB mount mechanism points. Although this will not be discussed, each ML configuration resulted in different modal parameter estimates as expected, due to the change in ML boundary condition. Additionally, only the driving point functions will be displayed for each modal test due to the large number of frequency response functions calculated (5 uncorrelated force inputs with 361 accelerometer responses results in 1805 FRFs!). Typically, if the excitation locations are sufficiently selected, the driving points should exhibit all the modes of a structure. Finally, only representative plots will be shown, with no units displayed on the axes.

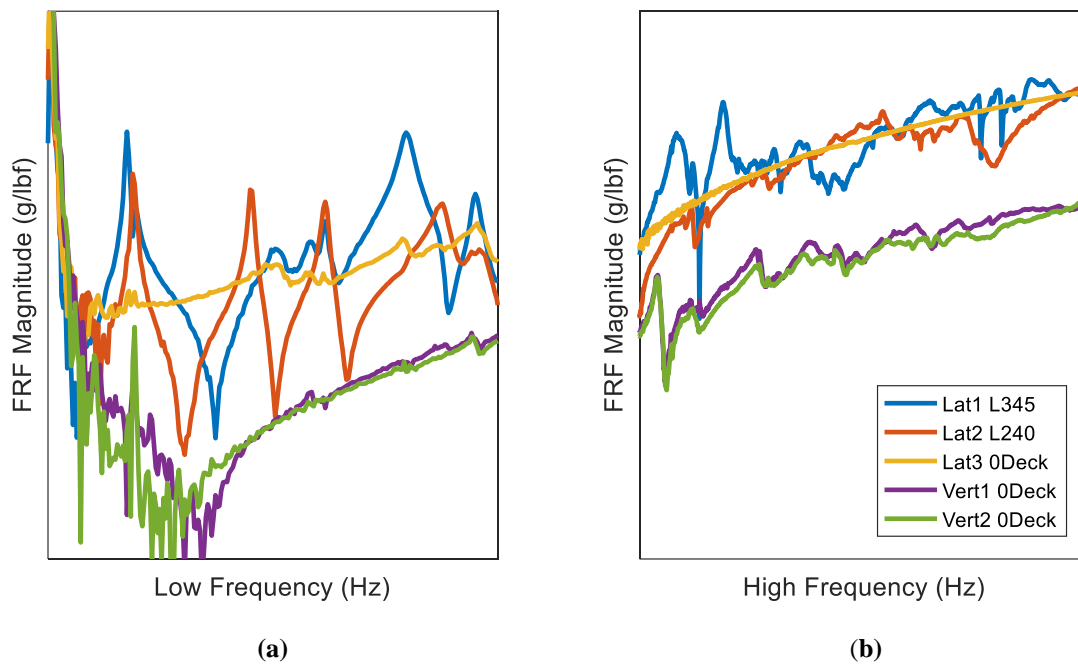
The input force power spectral densities (PSD) achieved by the shaker test fixtures for the multi-shaker random modal tests are shown in Figure 10 for both the low frequency band (0 Hz to 3 Hz) and high frequency band (3 Hz to 12 Hz). Both data sets are plotted on the x-axis with their respective input frequencies and have the same y-axis scale for comparison. The legend indicates the shaker configuration (lateral or vertical) and the ML level (0-deck, 240-ft, 345-ft), as well as the RMS force levels calculated from the data.



**Figure 10: Multi-Shaker Random Input Force PSD (a) Low Frequency and (b) High Frequency**

As seen in the low frequency PSD of Figure 10(a), the force input values range from 367 lbf-RMS to 759 lbf-RMS, with the vertical shakers contributing to the lower force values. The magnitudes for the vertical shakers also drop off when approaching 0 Hz, as compared with the lateral shakers. This may have been due to the air bags in the vertical shakers that prevented the shaker from reaching full displacement when retracted, as a lower displacement results in a lower force. The lateral shakers however, did not use airbags and could travel a majority of the 4-inch displacement range, resulting in the higher force values near 0 Hz. Additionally, the lateral shakers had more inertial mass than the vertical shakers, which may also have resulted in more force output at lower frequencies. For the high frequency PSD of Figure 10(b), the force inputs range from 277 lbf-RMS to 1007 lbf-RMS, with the already discussed problematic shaker (0-Deck Lateral) being the outlier with the lowest force value.

The calculated frequency response functions (FRF) for the driving points (shaker locations) of the multi-shaker random modal tests are shown in Figure 11, for both the low frequency excitation band (0 Hz to 3 Hz) and high frequency excitation band (3 Hz to 12 Hz). Again, the data sets are plotted on the x-axis with their respective input frequencies and have the same y-axis scale for comparison. The legend lists the FRF measurement locations and the colors correspond to the input force PSDs shown in Figure 10.

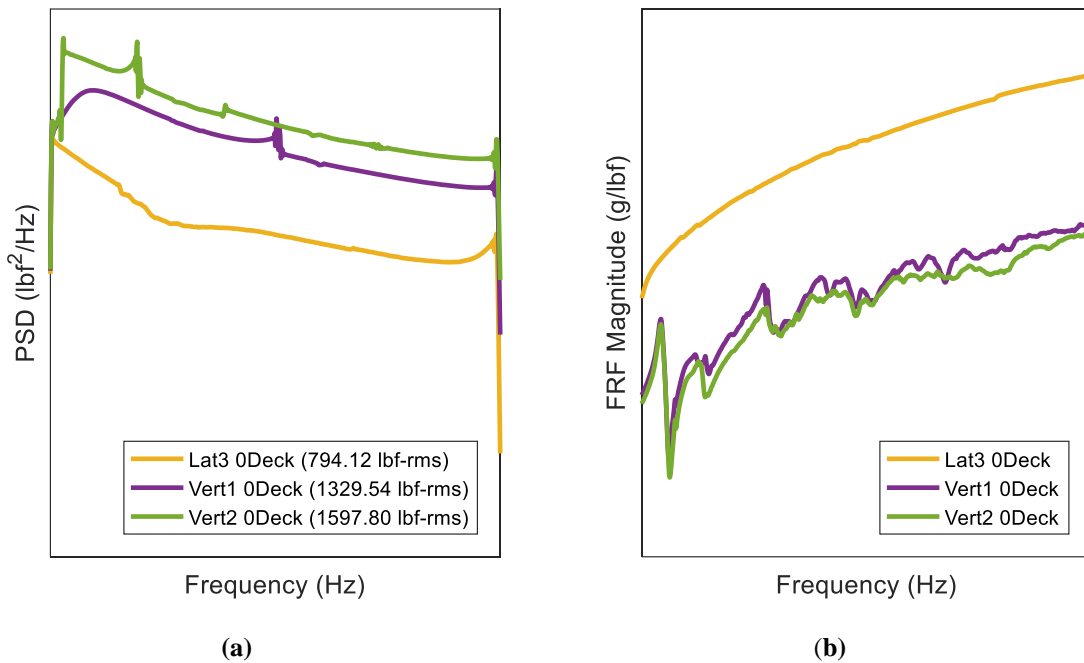


**Figure 11: Multi-Shaker Random Driving Point FRF (a) Low Frequency and (b) High Frequency**

Several observations regarding the dynamic response of the Mobile Launcher can be made from the driving point FRFs in Figure 11. First, the lateral shakers display an overall response of about an order of magnitude larger than the vertical shakers. This is expected, as the ML should be more dynamic and have more response in any lateral direction than in the vertical direction, primarily due to the tower. Second, the Level 345 and Level 240 lateral shakers, which were configured 90-degrees apart in the lateral plane, exhibit many clearly defined modes (peaks) of the tower. Third, the 0-Deck lateral shaker shows a few peaks with much less magnitude when compared with the tower lateral shakers in the low frequency plot, and hardly any peaks in the high frequency plot. This is to be expected, as the base would not be expected to respond much lateral modes, and hardly at all for the higher modes. Finally, the 0-Deck vertical shakers exhibit very noisy FRFs at very low frequencies, which indicate the lack of response at these frequencies. However, at higher frequencies, there are definite peaks indicating contribution to the higher frequency, vertical modes.

A multi-shaker sine sweep was performed with the three 0-Deck shaker test fixtures following the multi-shaker random testing to verify the results from the multi-shaker random data, particularly the vertical modes. While there are known equations to determine the adequate sweep rate based on damping values and frequencies of interest, due to the tight test schedule, the sweep rate for the ML was determined by frequency range and the desire to perform a multi-sine test with a one hour duration. Therefore, the multi-shaker inputs signals, created in MATLAB with ATA-authored software, consisted of a 4-Volt amplitude down sweep from 12 Hz to 3 Hz with a logarithmic sweep rate of 0.0107 dec/min for a total signal time of 3616 seconds. The ramp up/down time for each shaker was 8 seconds, and the wrap method was used.

The multi-sine sweep results, consisting of the force input PSD and driving point FRF, are shown in Figure 12. As before, the PSD legend indicates the shaker configuration (lateral or vertical) and the ML level (0-deck) as well as the RMS force levels calculated from the data. The FRF legend displays the measurement location, with the colors corresponding to those shown in the input force PSD. For ease of comparison, the colors for the each function are the same as in the multi-shaker random results of Figure 10 and Figure 11.



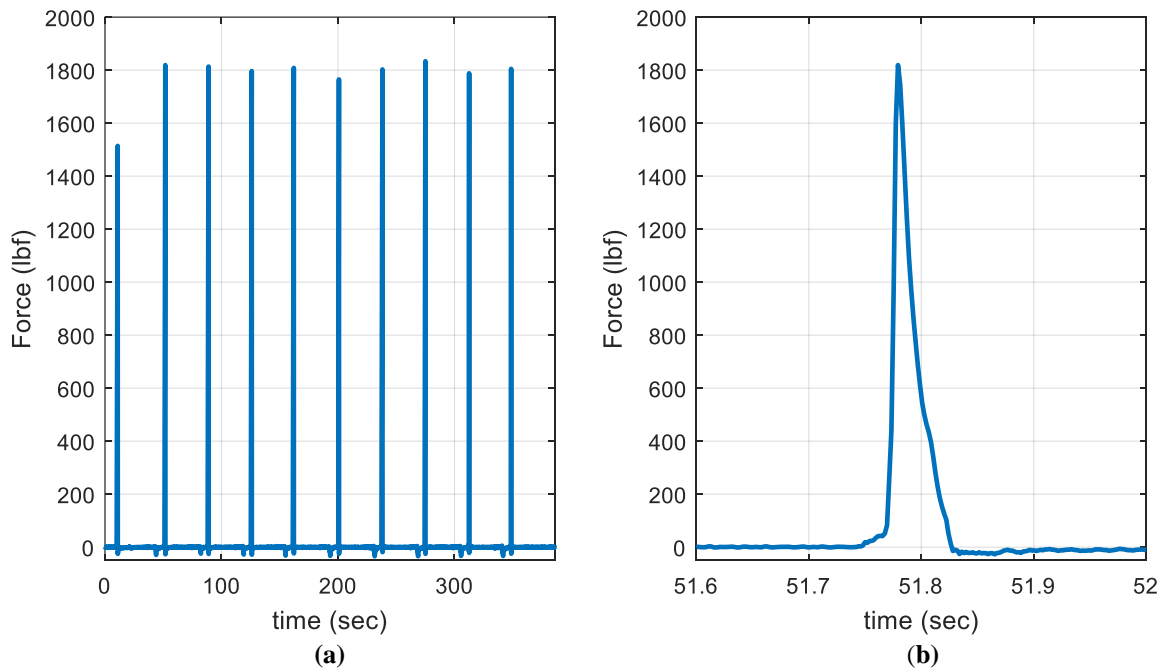
**Figure 12: Multi-Shaker Sine Sweep (a) Input Force PSD and (b) Driving Point FRF**

In the PSD plot of Figure 12(a), the vertical force input values ranged from 1329 lbf-RMS to 1597 lbf-RMS, while the lateral force input was the lowest value of 794 lbf-RMS. Some of this difference may have been due to the 594-lbs difference in the moving mass between the lateral and vertical shaker test fixtures. However, upon closer inspection of the recorded time history, the lateral input signal did not appear as a clean sine wave, but appeared as a sine wave with additional higher frequency content present. Despite these additional frequencies, the force input into the ML by the 0-Deck lateral shaker was measured, so the data was considered valid for this multi-sine test.

Despite the decreased force, the 0-Deck lateral shaker displayed a smooth PSD curve, whereas the 0-Deck vertical 1 shaker and vertical 2 shaker have large noisy blips. These larger blips are artifacts of using the wrap method when applying multi-sine with a sweep rate that may be too fast. With the wrap method, these shakers began and ended the sweep at these corresponding frequencies with an 8-second ramp up and ramp down. Even with a 95% overlap, the ramping causes some input frequencies to be improperly averaged or missed altogether. With a low enough sweep rate, this artifact would be reduced or go away completely.

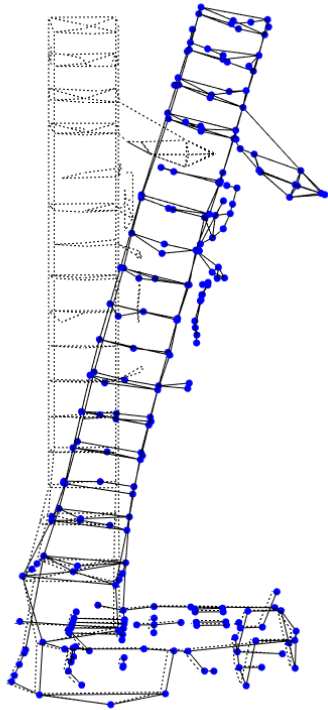
In the multi-sine sweep FRF plot of Figure 12(b), the 0-Deck lateral shaker appears to display a stiffness line leading to the first dominant lateral mode of the 0-Deck. The vertical shakers however, display many peaks in this frequency range, which indicate many vertical modes in the excitation frequency range. Additionally, the multi-sine FRF is much cleaner when compared with the multi-shaker random FRF of Figure 11(b), which can lead to much cleaner modal extraction with less scatter and uncertainty.

The final test performed was the impact drop tower testing performed at three locations on the 0-Deck to verify the frequency response due to lack of input from the existing shaker locations. For each drop tower test, 10 impacts were performed with approximately 30 seconds between each impact while the data was recorded as one continuous time history. The time history of one of the impact test locations is shown in Figure 13, where the entire time history is plotted on the left and a zoomed-in view of the second impact is plotted on the right. Disregarding the first impact, forces of about 1800-lbf were consistently achieved with the drop tower. The width of the second impact was approximately 0.05 seconds, which resulted in a 20 dB roll-off of the input power around 20 Hz, providing concentrated energy in the bandwidth of interest. This data was not fully analyzed by the MSFC Modal Test Team, but was recorded by request of the modal estimation team (which will be subsequently discussed), therefore, no spectral analysis results will be shown here.

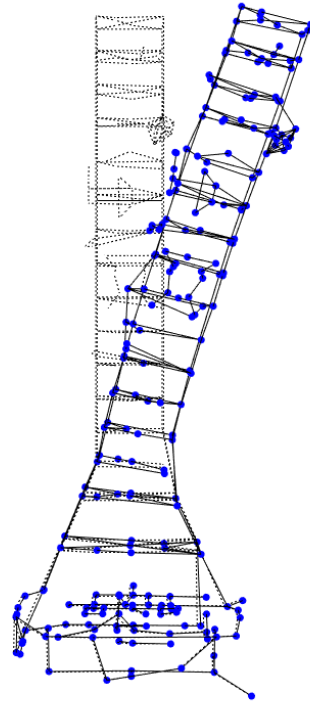


**Figure 13: Impact Drop Tower Time History (a) All Impacts and (b) Zoomed-In Impact**

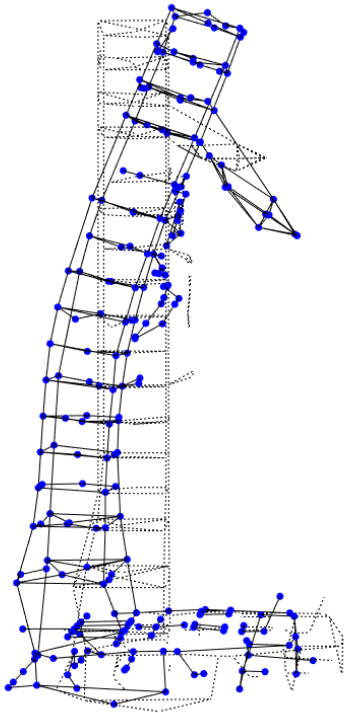
Both the multi-shaker random data and the multi-sine shaker data were used in the modal parameter estimation analysis performed by the MSFC Modal Test Team using Rational Fraction Polynomial-Z method in the BK Connect Modal Analysis software. For modes below 1 Hz, the low sensitivity (100 mV/g) accelerometers were removed from the data set, as the higher noise floor present in the data at these low frequencies resulted in false or inaccurate mode estimation. Because not every degree-of-freedom was measured for every node in the test display model of Figure 2, a Guyan back expansion was performed on the measured, extracted mode shapes with the Test Analysis Model stiffness matrix, to fill-out the unmeasured modal vectors. A selection of the resulting, back-expanded mode shapes of the Mobile Launcher are shown in Figure 14.



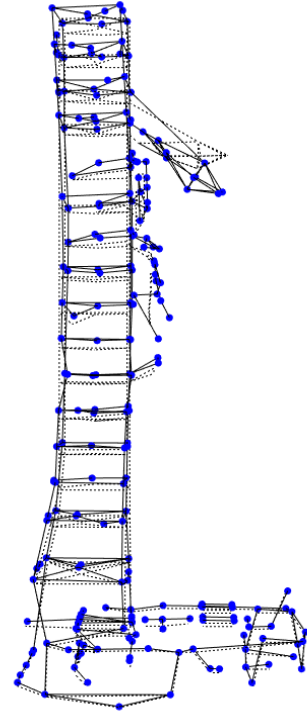
**Mode 1: Tower Bending in Z**



**Mode 2: Tower Bending in Y**



**Mode 4: Tower Bending in Z with Base Motion**



**Mode 11: Tower Vertical with Base Motion**

**Figure 14: Selected Mode Shapes of Mobile Launcher**

## RECOMMENDATIONS

The Mobile Launcher was only made available for modal testing for a short amount of time due ongoing preparations of the structure for the Space Launch System. To ensure that the available time would be used as efficiently as possible, all modal test equipment was thoroughly tested at MSFC, and once installed at KSC prior to the actual test date. A few examples include operating the B&K data acquisition system and hardware with all 400+ channels connected and recording data for hours at a time. The five hydraulic shaker test fixtures were assembled operated all at once in the laboratory at MSFC to verify proper simultaneous operation and expected force levels. Once installed on the ML at KSC, the shakers were operated one at a time, locally, at very low levels. A full dry run integrating the DAQ, a lateral hydraulic shaker, accelerometers, and load cell was performed on the Saturn V Dynamic Test Stand at MSFC to simulate the data acquisition process on a similar structure. Random vibration and sine sweep tests were run on the Test Stand, and the results helped determine optimal DAQ settings, sweep rates, and data analysis methods. This extensive pre-test work was vital to the completion of the Mobile Launcher modal testing within the allotted timeframe.

The hydraulic shaker monitoring system proved to be a valuable addition to the test control center by providing immediate information regarding the status of all five shakers to the DAQ engineer during startup and testing. While the data acquisition system could provide the shaker displacement and force data during a test, it was also measuring 381 channels simultaneously, which complicates the display, even if the display is 42-inches large. Having a dedicated system for displaying this information during a test allows for quick adjustments to the shakers without scrolling through all the additional channels, saving time, mental stress, and eye strain. Diagnosing any problems with the shakers becomes immensely easier as well, as the raw data signals can be viewed for problems such as discontinuities or DC offsets. The video system was not as important, but served as a sanity check for the DAQ engineer and a video record of the test.

The most vital aspect of keeping the modal test within schedule was the establishment of a completely separate data analysis team that operated onsite, in parallel to the data acquisition team. The data analysis team consisted of modal analysis engineers from other NASA facilities and industry. Following each modal test, the time history data was handed over to the analysis team, who would perform independent modal parameter estimation, allowing the test team to focus on performing the next test. Close communication between the two teams allowed for adjustments to the test procedure as necessary, in order to guarantee all target modes were measured. Most importantly, having two separate teams working in parallel allowed enough time for sleep between test days, which prevents exhaustion and encourages good critical thinking at test time.

Finally, it is worth noting that insect repellent is required for any modal testing performed in Florida, USA. Even if the test item is in a large high-bay facility with the exterior doors closed, mosquitos and other insects will find test engineers and proceed to pester and bite them, predominantly at night. With insect repellent, modal tests can be performed in relative peace.

## CONCLUSIONS

A successful modal test was performed on the NASA Mobile Launcher at Kennedy Space Center by the Space Launch System Test Team to validate an analytical model of the launcher, in preparation of the upcoming SLS Integrated Modal Test. Excitation of the Mobile Launcher was achieved with five hydraulic shaker test fixtures, configured in the lateral and vertical directions, which were used to perform both multi-shaker random vibration as well as multi-shaker sine sweep modal tests. A portable drop tower was also used to perform impact modal testing on the 0-Deck platform at a few locations not sufficiently excited by the shakers. Response of the Mobile Launcher was measured with 361 accelerometers. Force, acceleration, displacement, and voltage drive time history signals were recorded with a B&K data acquisition system. Three Mobile Launcher support configurations were tested in the Vehicle Assembly Building over the frequency range of 0 Hz to 12 Hz. Modal parameters were estimated from the data and verified to include all target modes from the analytical model.

The primary challenges met with this modal test included exciting such a large structure as well as testing within a short timeframe. The shaker test fixtures used for excitation implemented hydraulic shakers to move an inertial mass, providing inertial acceleration with 4-inches of displacement down to 0 Hz. Pre-test analysis ensured that the locations and directions of the shaker test fixtures would sufficiently excite all modes of interest, with an impact drop tower to excite a few additional locations. To meet the challenging schedule, all modal test equipment, from the shakers to the DAQ, was assembled and



operated to their limits at MSFC, in order reduce time spent at the test site debugging or repairing equipment. At the Mobile Launcher test site, a shaker monitoring system was implemented with the data acquisitions system to provide immediate displacement and force information, as well as video, to the DAQ engineer during testing. Additionally, a second team of modal analysts was brought in to perform an independent modal parameter estimation on the data, while the MSFC test team continued to test. The division of test and data analysis responsibilities saved schedule time, allowed engineers to focus on their particular tasks, and most importantly, allowed for sufficient time for sleep between test days.

Modal parameter estimates from the Mobile Launcher modal test will ultimately be used to validate an analytical model of the structure. Because the ML will provide the boundary condition for the upcoming SLS Integrated Modal Test, the validated ML model will allow focus to remain on SLS vehicle model correlation during the IMT. Since the validated SLS model is required for flight certification, the Mobile Launcher modal test can be considered an integral step toward NASA and the SLS successfully reaching deep space and beyond.

## **ACKNOWLEDGEMENTS**

Modal testing the Mobile Launcher was a massive undertaking that the authors did not perform alone. Therefore, the authors would like to proudly thank Jason Perry, Alex McCool, and Felipe Mora of NASA Marshall Space Flight Center, James Bolding, Regina Chambers, and Josh Hicks of Aerie Aerospace, and Wulf Eckroth and Mark Tillet of KSC for all their work in preparing for, setting up, and assistance in performing a very large modal test in the hot, humid, and buggy Florida summer weather. Many thanks to Adam Carver, Jason Phelan, and Bryan Moran of the TOSC instrumentation crew for their very impressive, scary, and difficult job of instrumenting the Mobile Launcher. Critical onsite data quality assessments and mode extraction were performed by Vicente Suarez and Kenneth Pederson of Glenn Research Center, as well as, Kevin Napolitano of ATA Engineering. Finally, valuable pre-test analysis and test coordination support was provided by Clay Fulcher and Dan Lazor of MSFC and Chris Brown of KSC.

## **REFERENCES**

- [1] Photo credit: NASA/Ben Smegelsky, 2019.
- [2] “Mobile Launcher”, NASAfacts, [https://www.nasa.gov/sites/default/files/atoms/files/mobilelauncher\\_factsheet\\_v2.pdf](https://www.nasa.gov/sites/default/files/atoms/files/mobilelauncher_factsheet_v2.pdf), 2018.
- [3] “Mobile Launcher Tower Umbilicals and Launch Accessories”, NASAfacts, [https://www.nasa.gov/sites/default/files/atoms/files/fs-2018-02-250-ksc-ml\\_umbilical\\_fact\\_sheet.pdf](https://www.nasa.gov/sites/default/files/atoms/files/fs-2018-02-250-ksc-ml_umbilical_fact_sheet.pdf), 2018.
- [4] Stasiunas, Eric C., Parks, Russel A., “Performing a Large-Scale Modal Test on the B2 Stand Crane at NASA’s Stennis Space Center,” IMAC-XXXVI Conference Proceedings, SEM, 2018.
- [5] Napolitano, Kevin, Linehan, Daniel, “Multiple Sine Sweep Excitation for Ground Vibration Tests,” IMAC-XXVII Conference Proceedings, SEM, 2009.
- [6] Hoople, Gordon, Napolitano, Kevin, “Implementation of Multi-Sine Sweep Excitation on a Large-Scale Aircraft,” IMAC-XXVIII Conference Proceedings, SEM, 2010.