

Sleep and Circadian Rhythms in the Sky and Space

Erin Flynn-Evans PhD MPH

Fatigue Countermeasures Laboratory

NASA Ames Research Center





Photo credit: Erin Flynn-Evans

What do we do in the Fatigue Countermeasures Laboratory?

What do we do in the Fatigue Countermeasures Laboratory?

National Aeronautics and Space Administration



Outline

- Background
 - How does sleep relate to performance?
- How do we measure performance?
 - PVT and NASA fatigue app
- What are we doing to help airline pilots?
 - Short haul aviation study
- What do we know about sleep in space?
- How do astronauts cope with sleep loss?
- Identifying factors that prevent astronauts from getting enough sleep in space
- Preparing astronauts to sleep on Mars

Factors Associated with Fatigue-Related Performance Impairment on Earth

- Acute sleep loss
- Chronic sleep loss
- Circadian misalignment
- Sleep inertia



Acute Sleep Loss = Performance Impairment

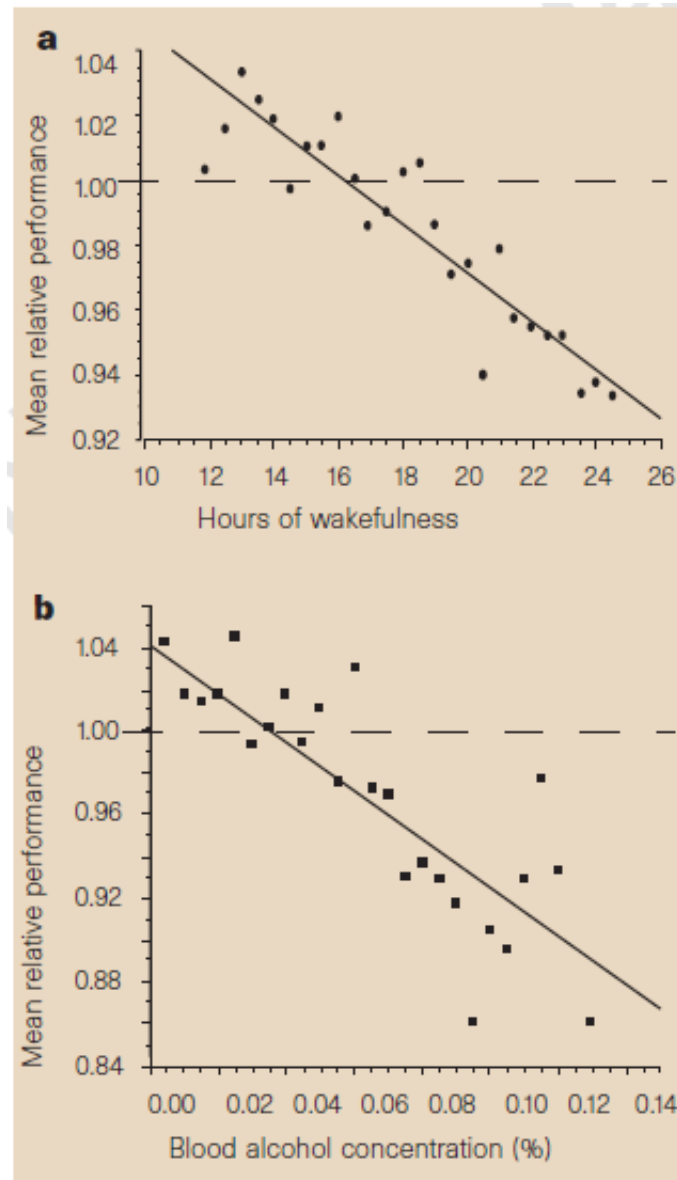

Dawson and Reid 1997, *Nature*

Chronic Sleep Loss = Performance Impairment

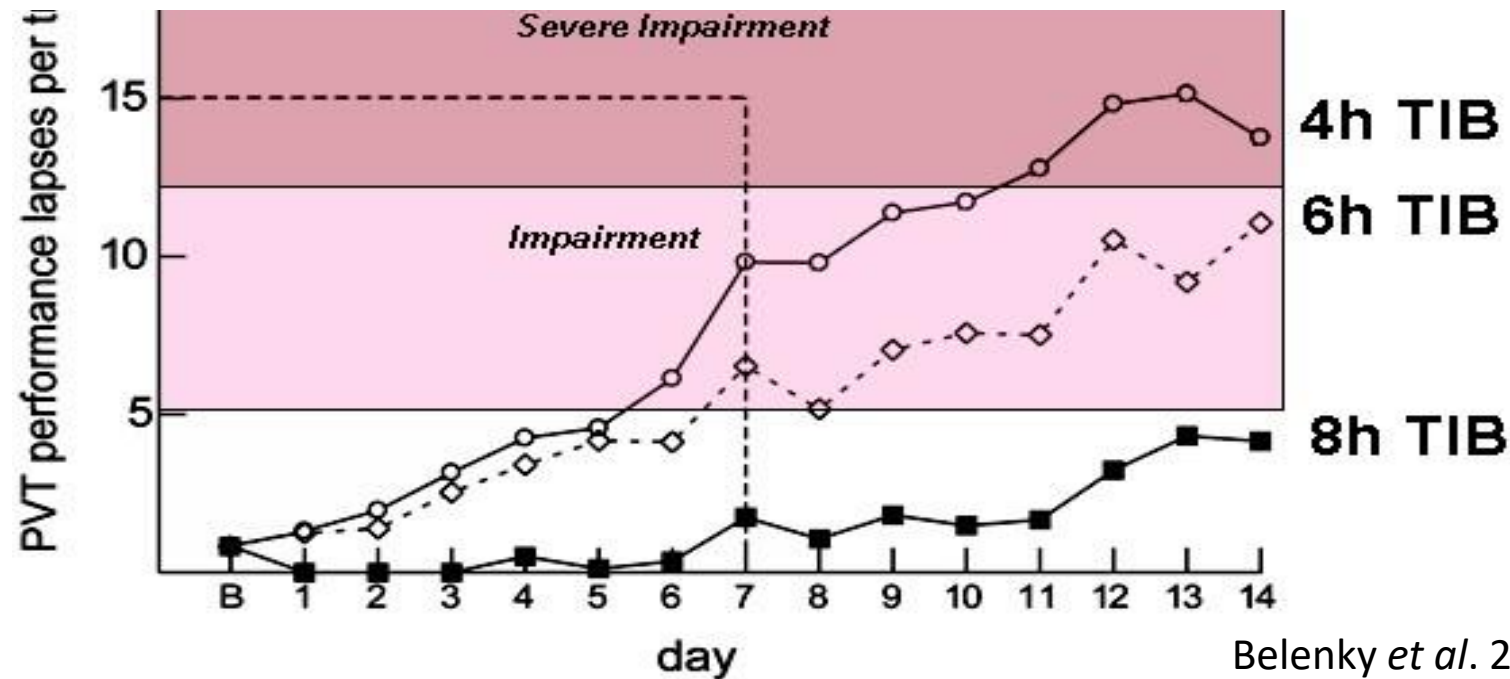
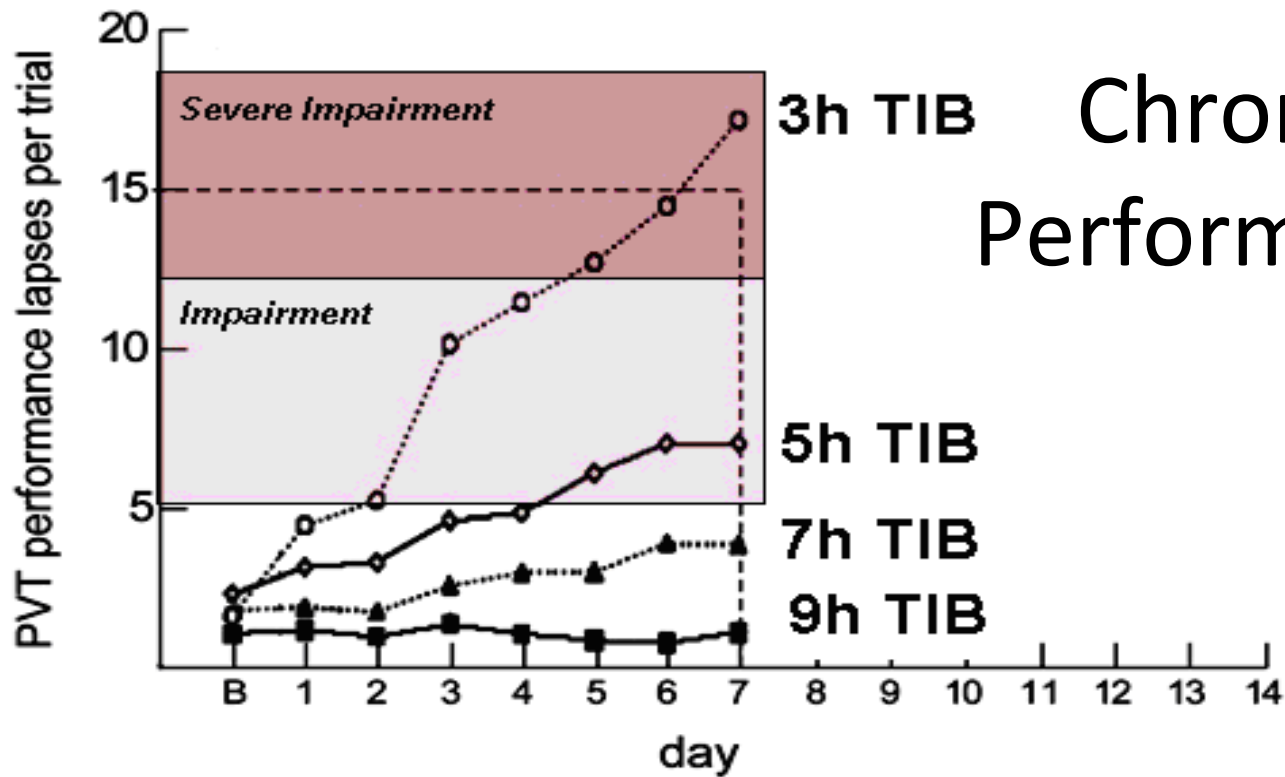

Sleep Inertia = Performance Impairment

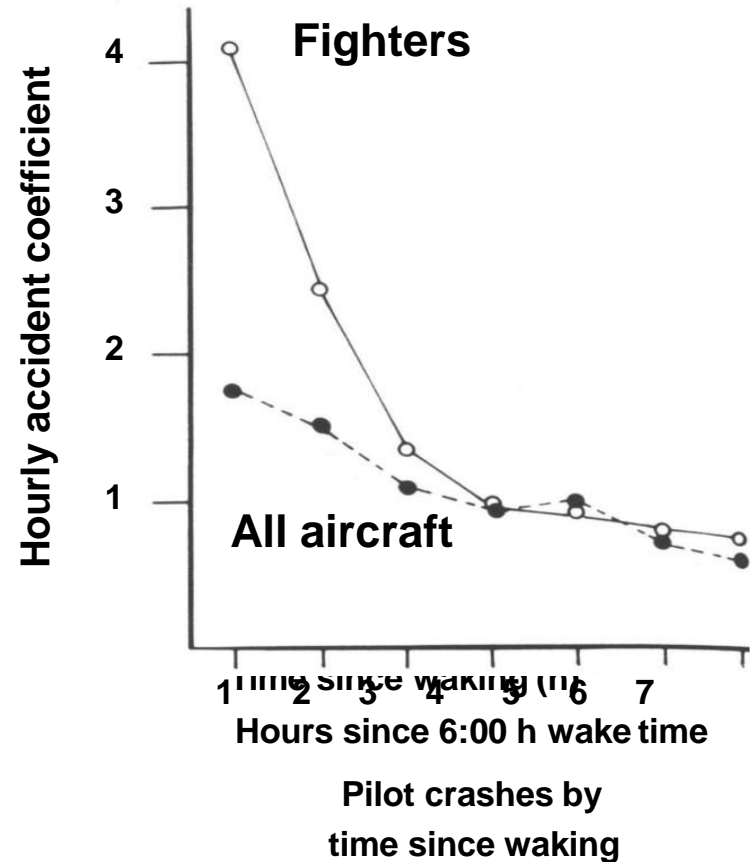
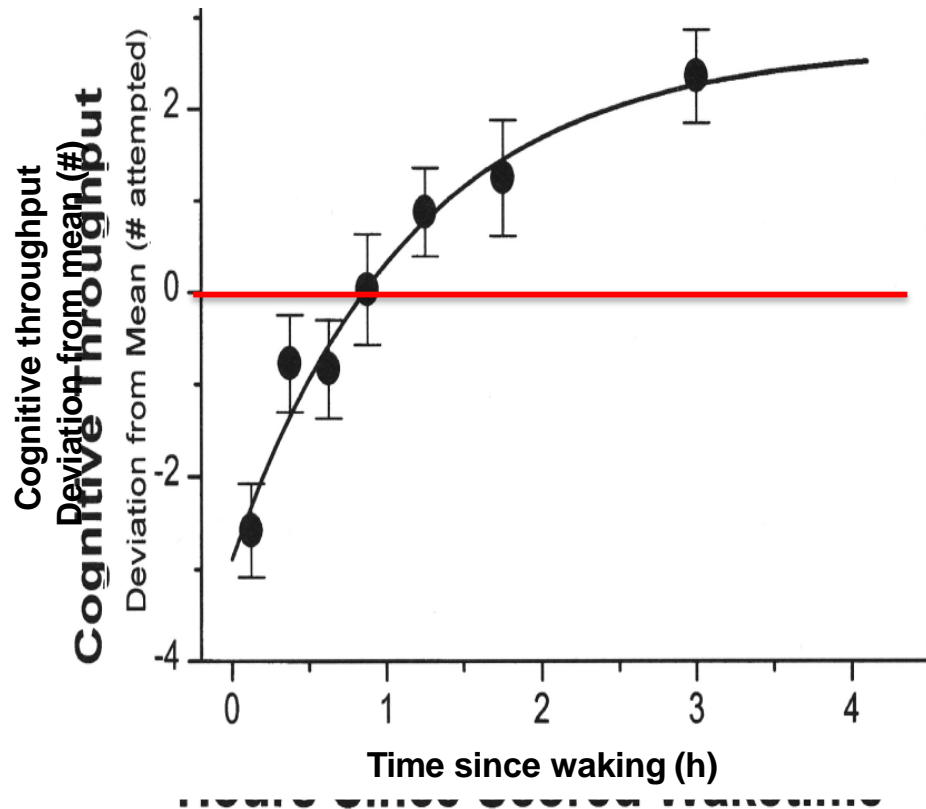

Circadian Misalignment = Performance Impairment

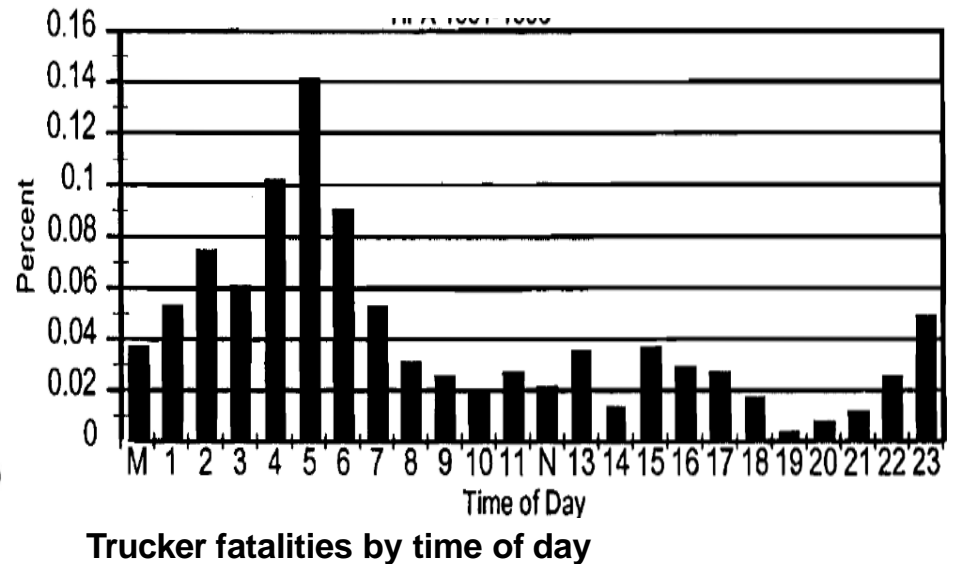
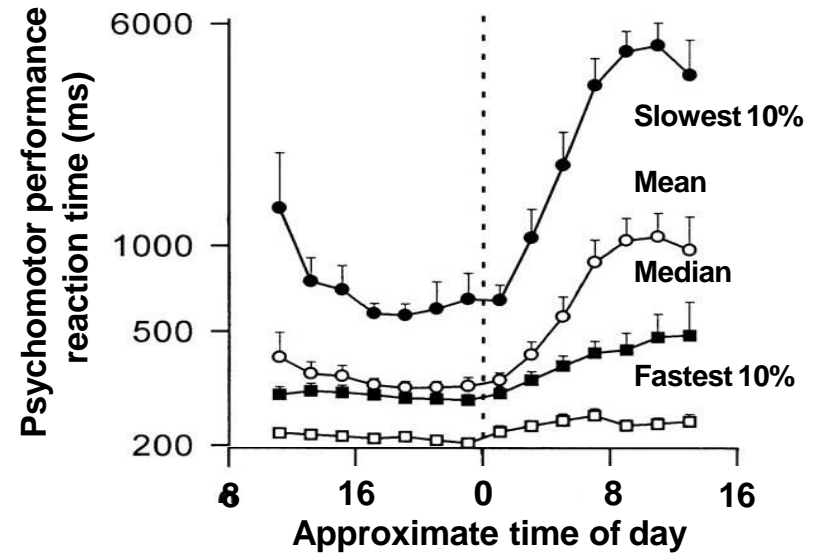
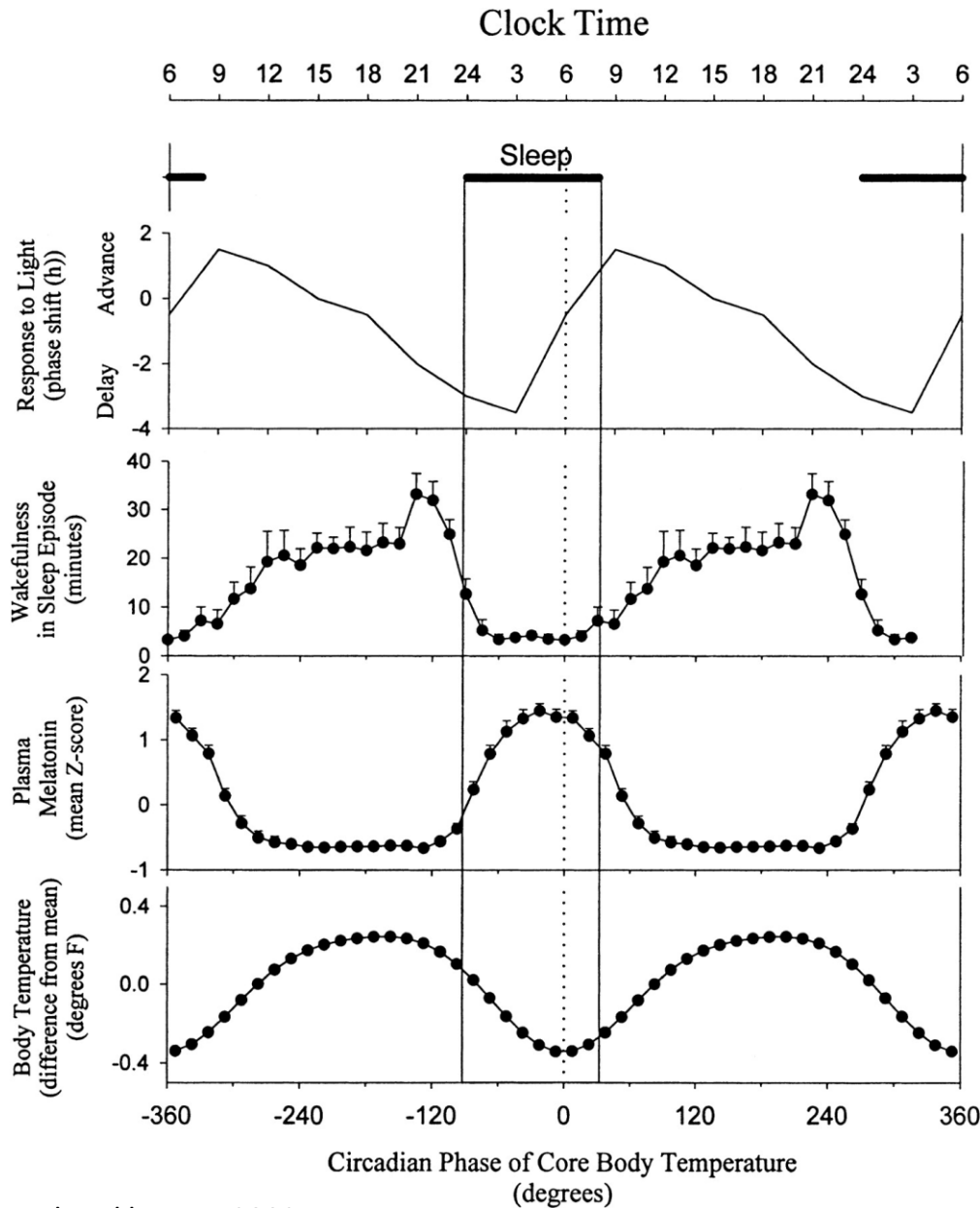

Circadian Nadir = Poorest Performance and Highest Sleep Drive

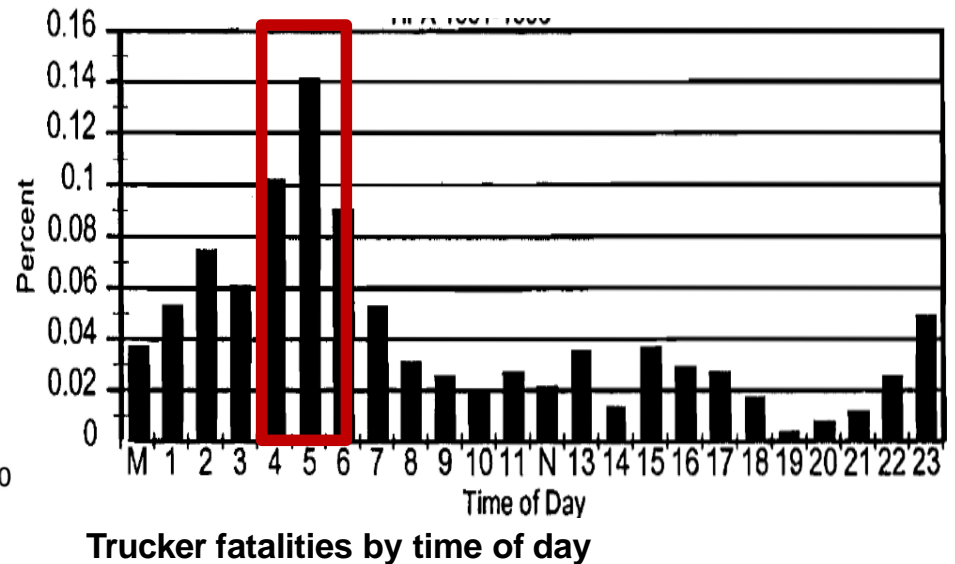
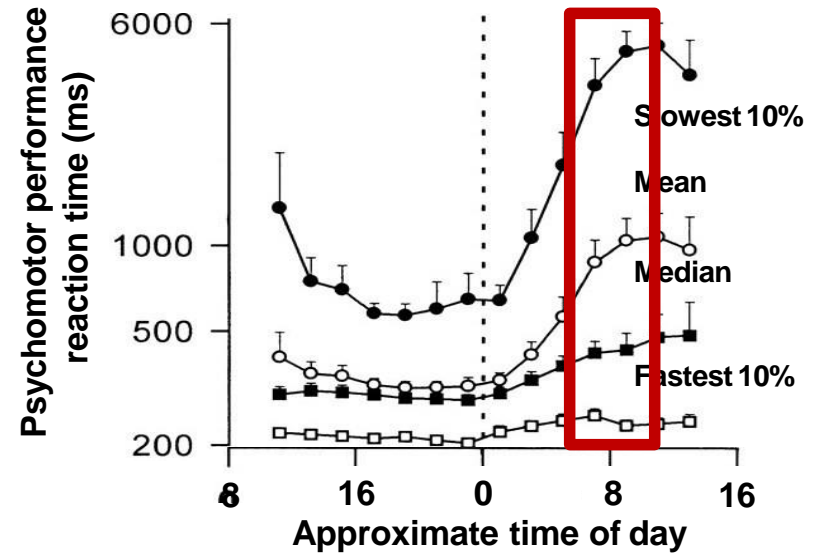
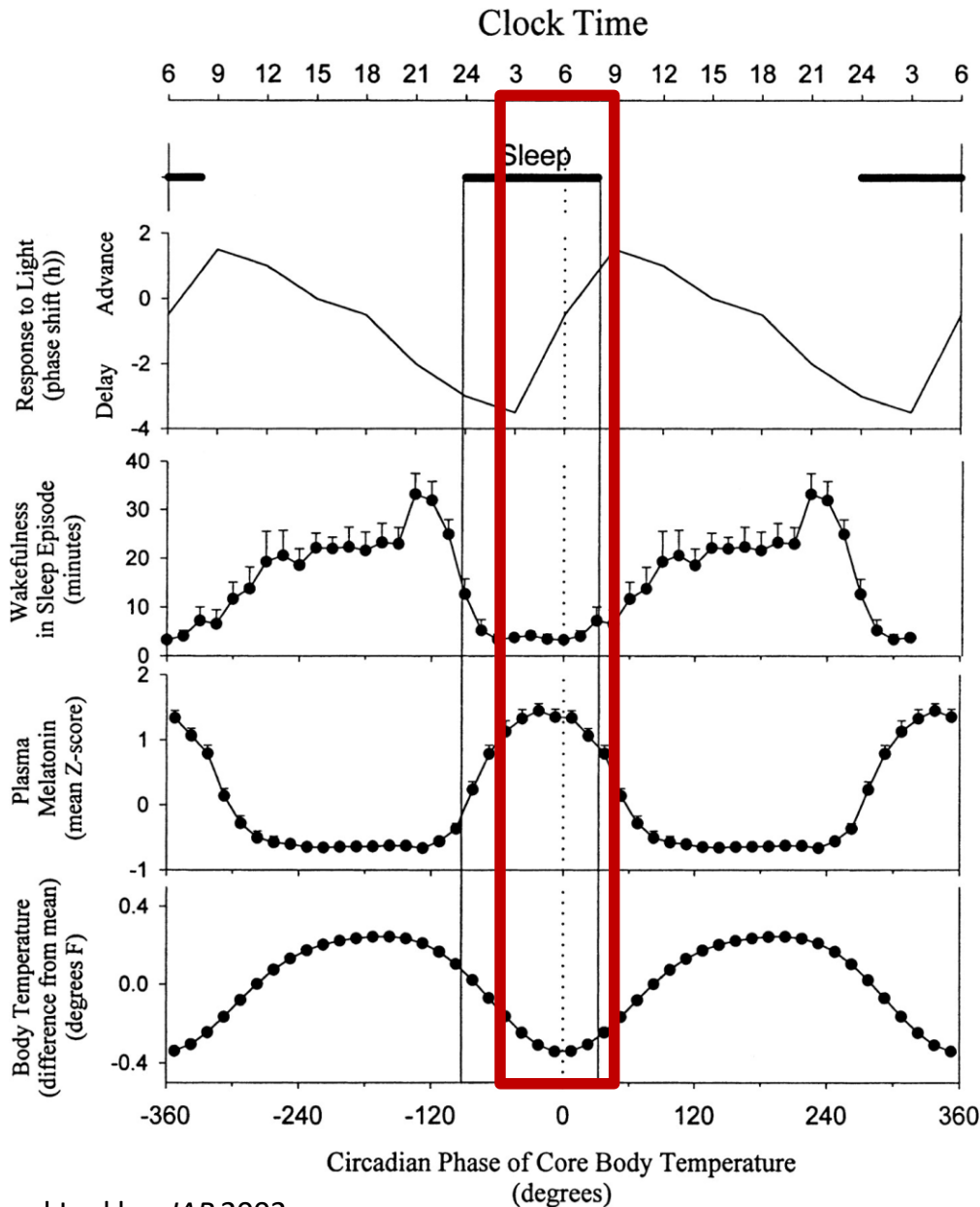

Circadian Wake Maintenance Zone = Lowest Sleep Drive

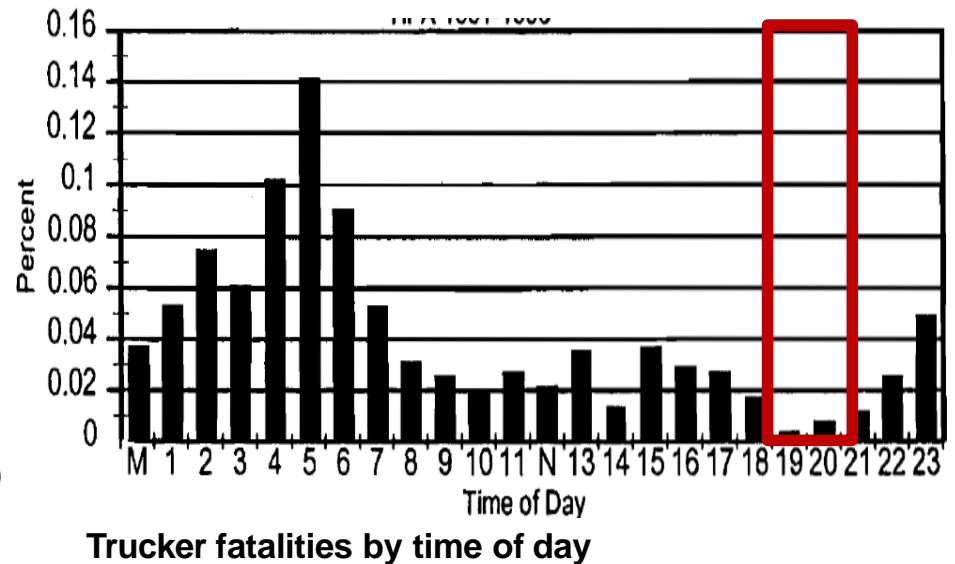
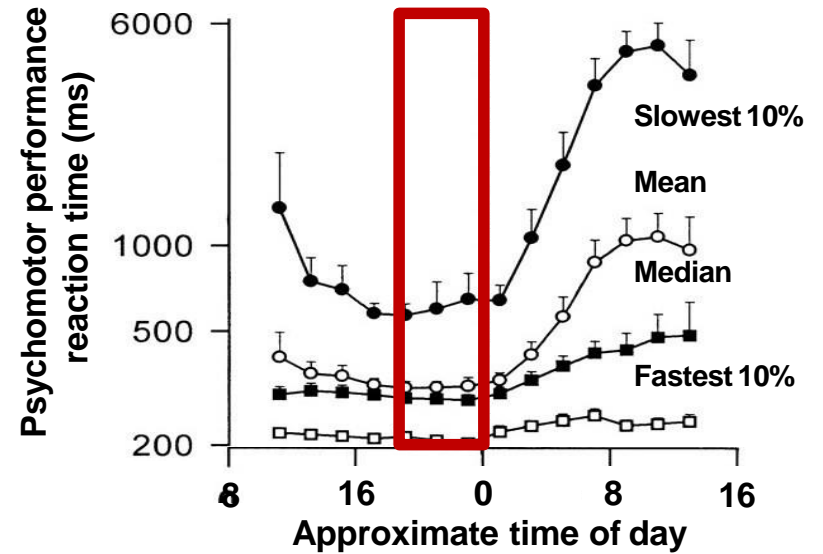
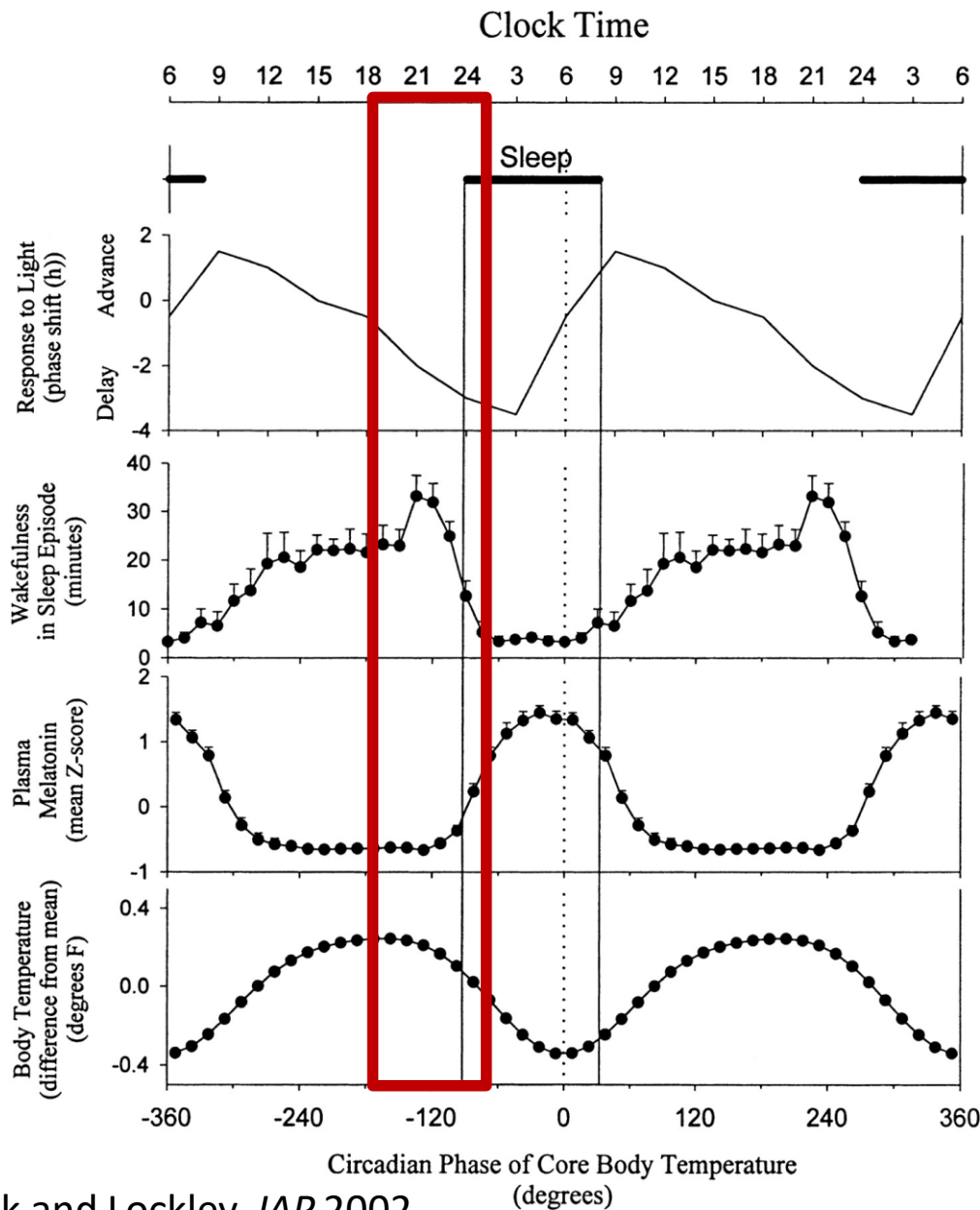

Circadian Rhythm is Reset by Light Exposure

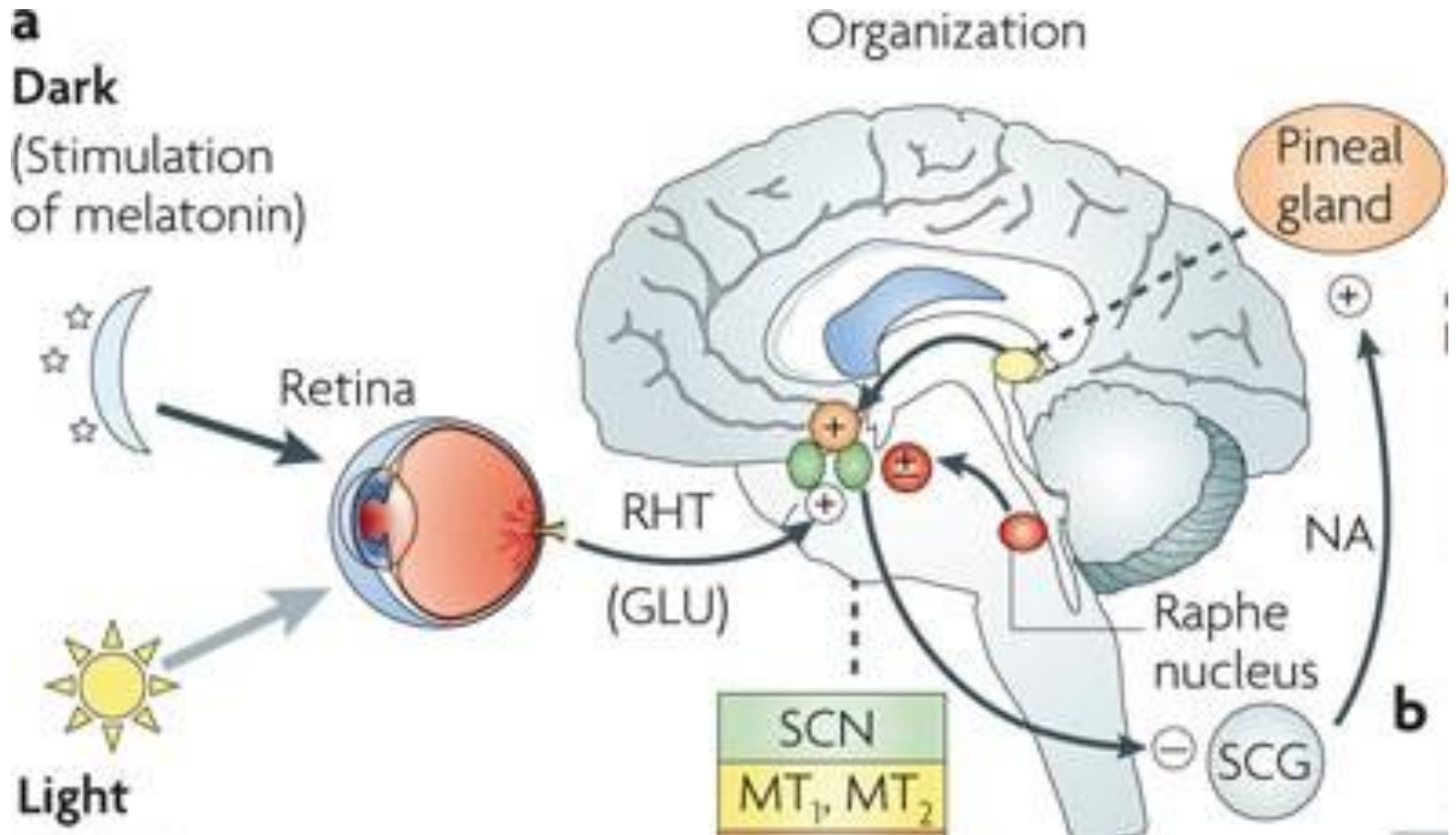

Properties of the Circadian Pacemaker

- Average circadian period ~ 24.2
 - Daily resetting through light required
- Limits to entrainment
- Most sensitive to short wavelength light (blue, 460 nm)
 - Least sensitive to long wavelength light (red)
- Circadian misalignment = short sleep
- Peripheral oscillators can become desynchronized from master pacemaker

Measuring Performance

- Psychomotor Vigilance Task (PVT)
 - Simple reaction time test
 - Common performance test
 - Sensitive to sleepiness
 - Outcomes include
 - Reaction time (rested ~ 250 milliseconds)
 - Lapses > 500 ms
- Not easy to use in the real world

NASA PVT

- Features consistent with PVT-192
 - ISI interval 2-10 s, randomly (rectangular distribution)
 - Stimulus represented by a milliseconds-counter in a small rectangular box
 - Left and right areas predefined on the screen to serve as left or right buttons
 - Immediate feedback

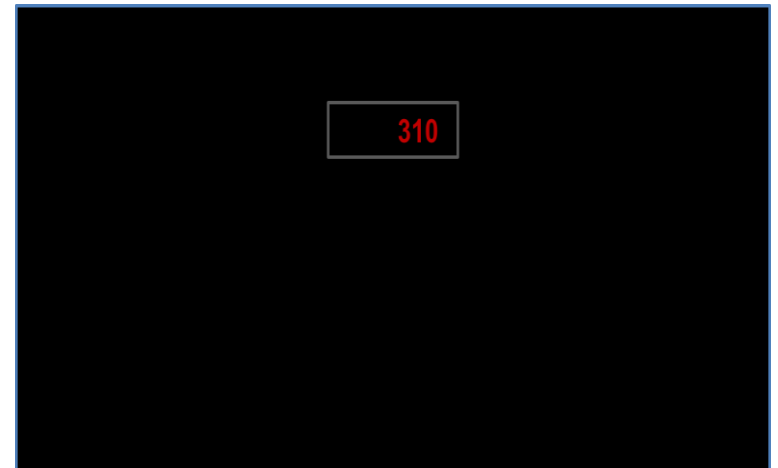
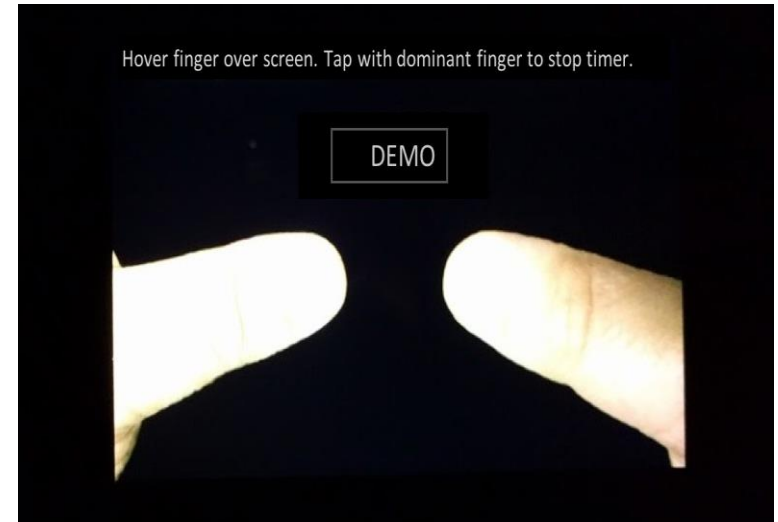

NASA PVT Validation: Sleep Deprivation Study

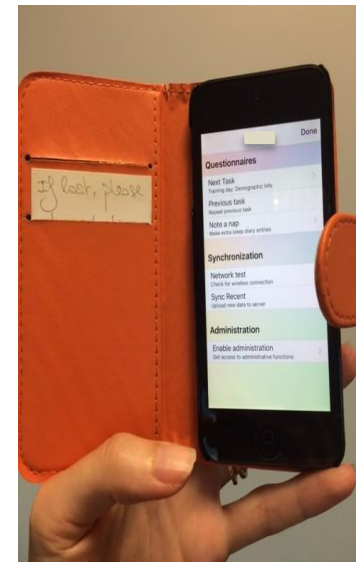
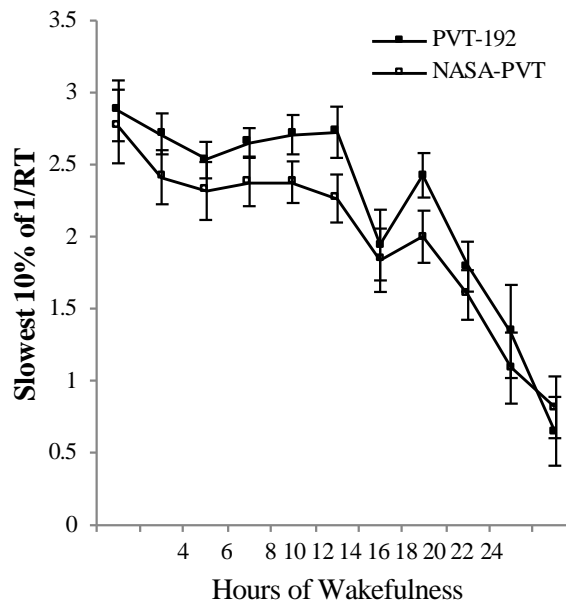
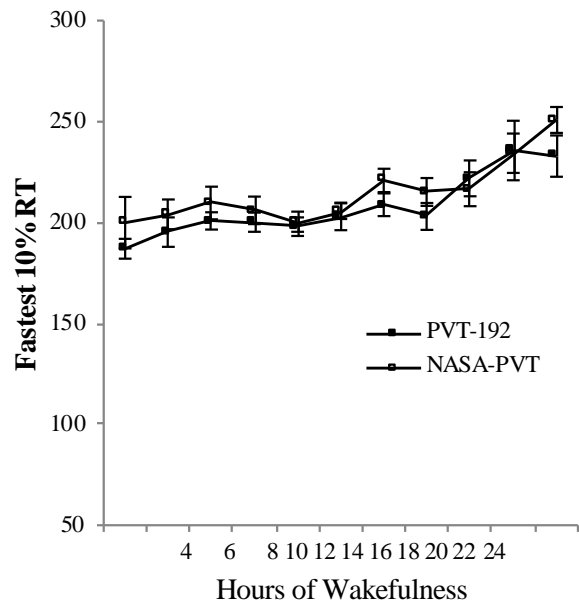
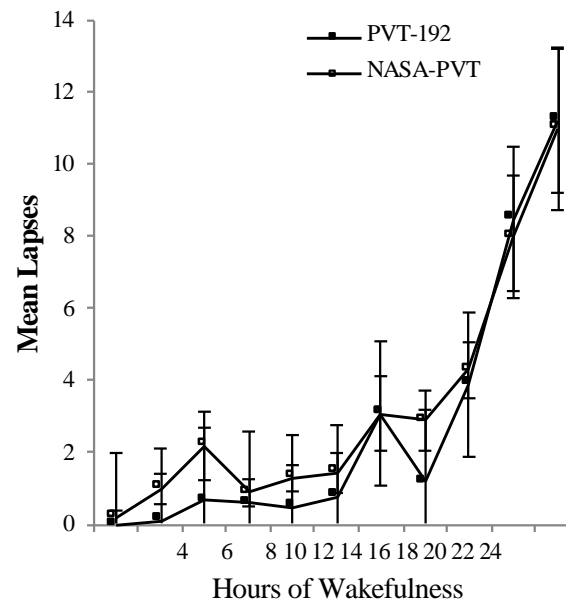
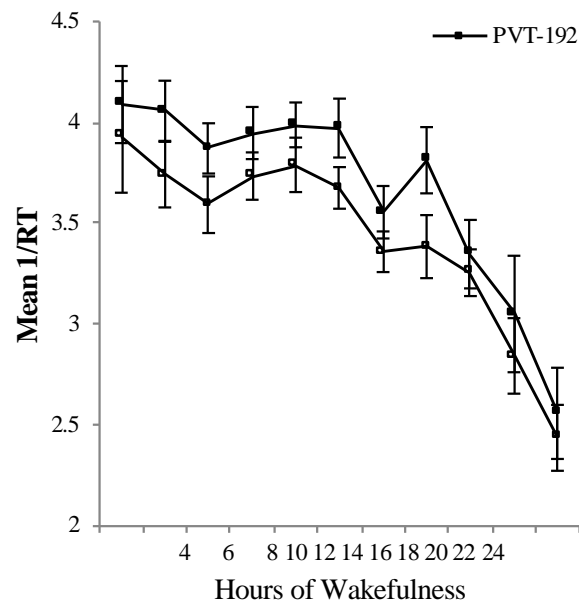

NASA Fatigue App

- Developed to enable inflight data collection
- Logic to take pilots through each activity at the appropriate time
- App includes objective and subjective measures
 - Sleep logs
 - Baseline questionnaires
 - Self-report scales
 - Hassle factors
 - Workload ratings
 - Psychomotor vigilance task

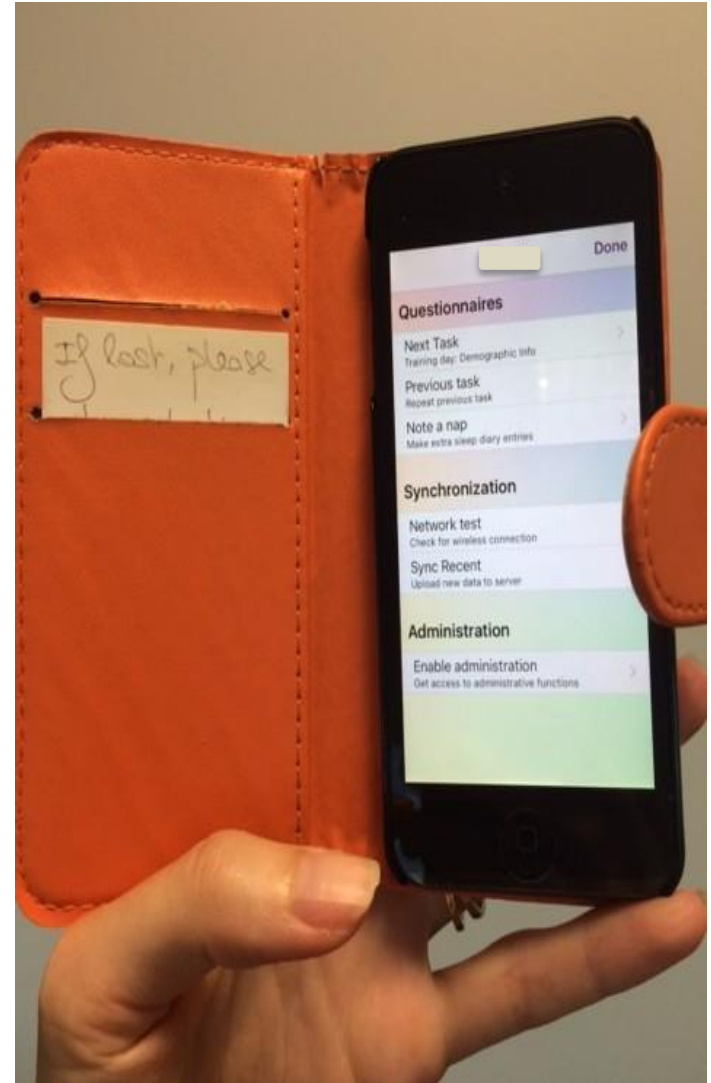

Research Question

Does work start time affect sleep and performance among airline pilots?

Short Haul Aviation Study

- Short haul study of 44 line pilots
 - Three schedule types
 - Assessment during work and rest days
 - Only daytime schedules
 - Return to domicile daily
 - Fatigue related outcome measures
 - Actigraphy
 - Urine collection for melatonin (circadian phase) assessment
 - PVT on iPod
 - Hassle factors
 - Sleep logs
 - Sleepiness scales, countermeasure logs

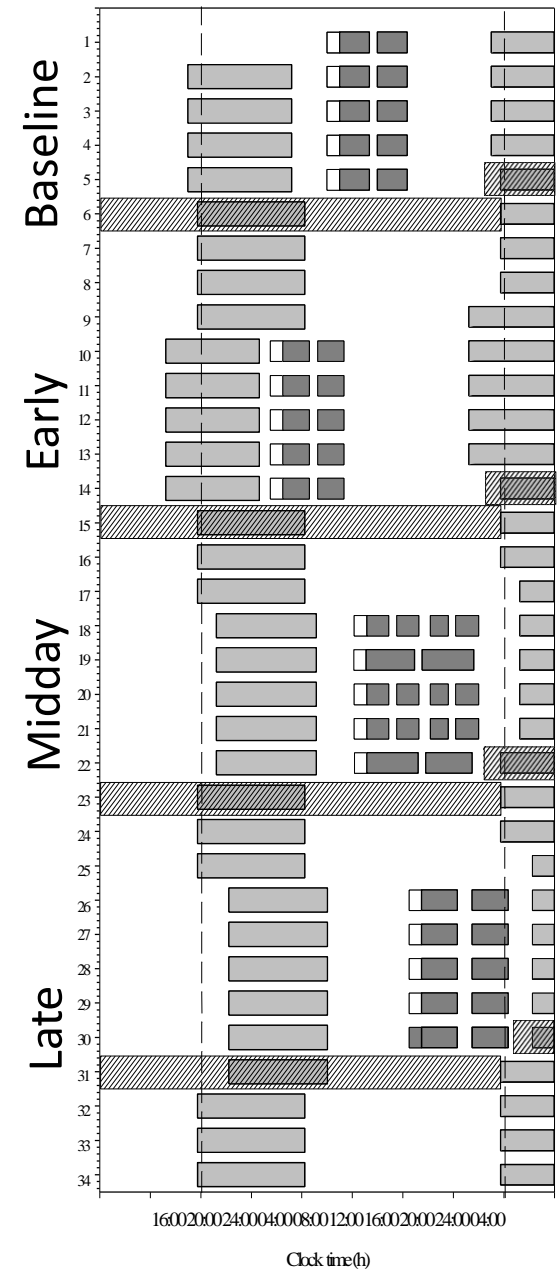

Short Haul Aviation Study

- Short haul study of 44 line pilots
 - Three schedule types
 - Assessment during work and rest days
 - Only daytime schedules
 - Return to domicile daily
 - Fatigue related outcome measures
 - Actigraphy
 - Urine collection for melatonin (circadian phase) assessment
 - PVT on iPod
 - Hassle factors
 - Sleep logs
 - Sleepiness scales, countermeasure logs

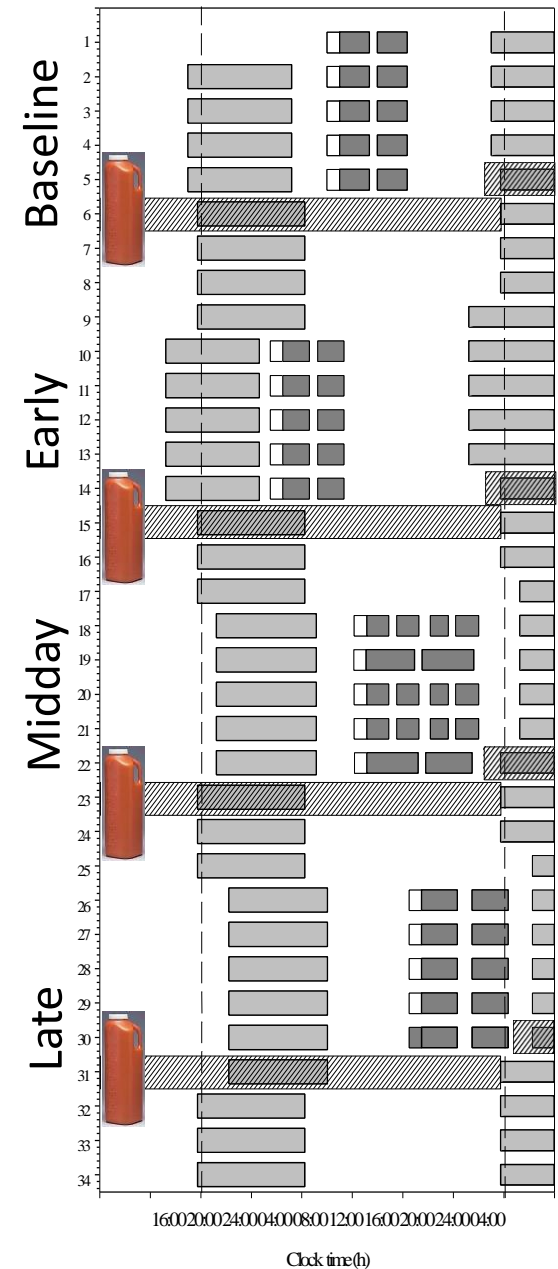

Short Haul Aviation Study

- Short haul study of 44 line pilots
 - Three schedule types
 - Assessment during work and rest days
 - Only daytime schedules
 - Return to domicile daily
 - Fatigue related outcome measures
 - Actigraphy
 - Urine collection for melatonin (circadian phase) assessment
 - PVT on iPod
 - Hassle factors
 - Sleep logs
 - Sleepiness scales, countermeasure logs

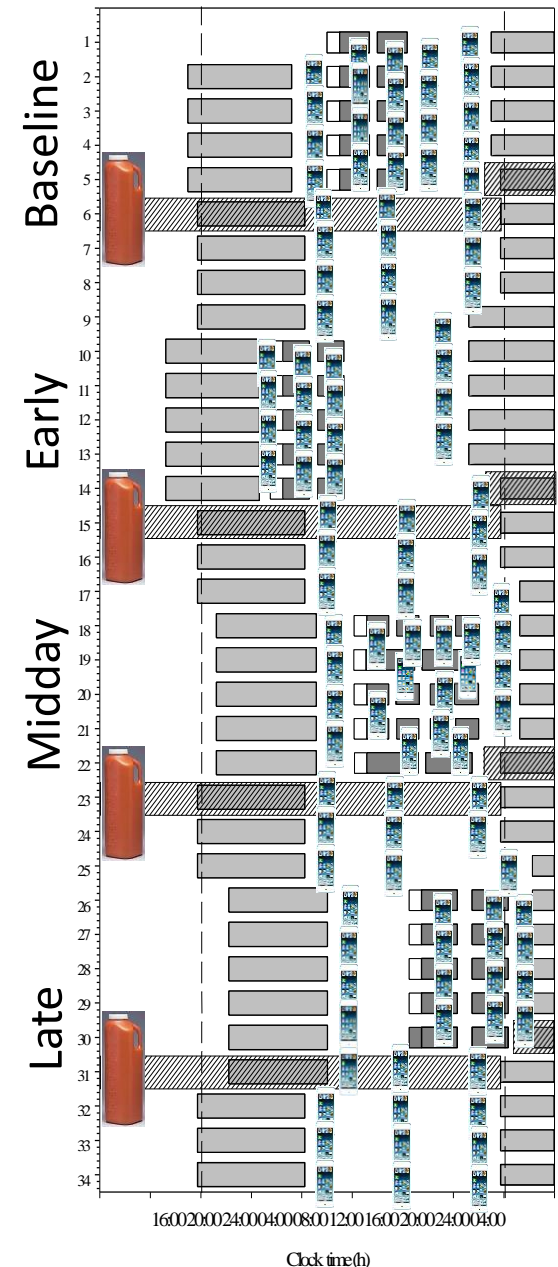

Sleep Outcomes Poorer during Early Starts

	n (study participants)	Total Sleep Time (h, SD)	Sleep Latency (m, SD)	Sleep Efficiency (%, SD)	Wake After Sleep Onset (m, SD)
Baseline (ref)	37	6.78 (0.86)	18 (22)	83 (7)	54 (37)
Early	41	5.70 (0.73)**	21 (17)	81 (7)	45 (30)*
Midday	41	6.83 (1.00)	16 (17)	83 (7)	53 (31)
Late	39	6.69 (0.93)	24 (28)	81 (9)	55 (40)
Rest days	42	6.82 (0.90)	19 (13)	80 (7)	62 (35)

Sleep Duration Remains Low by Day on Early Starts

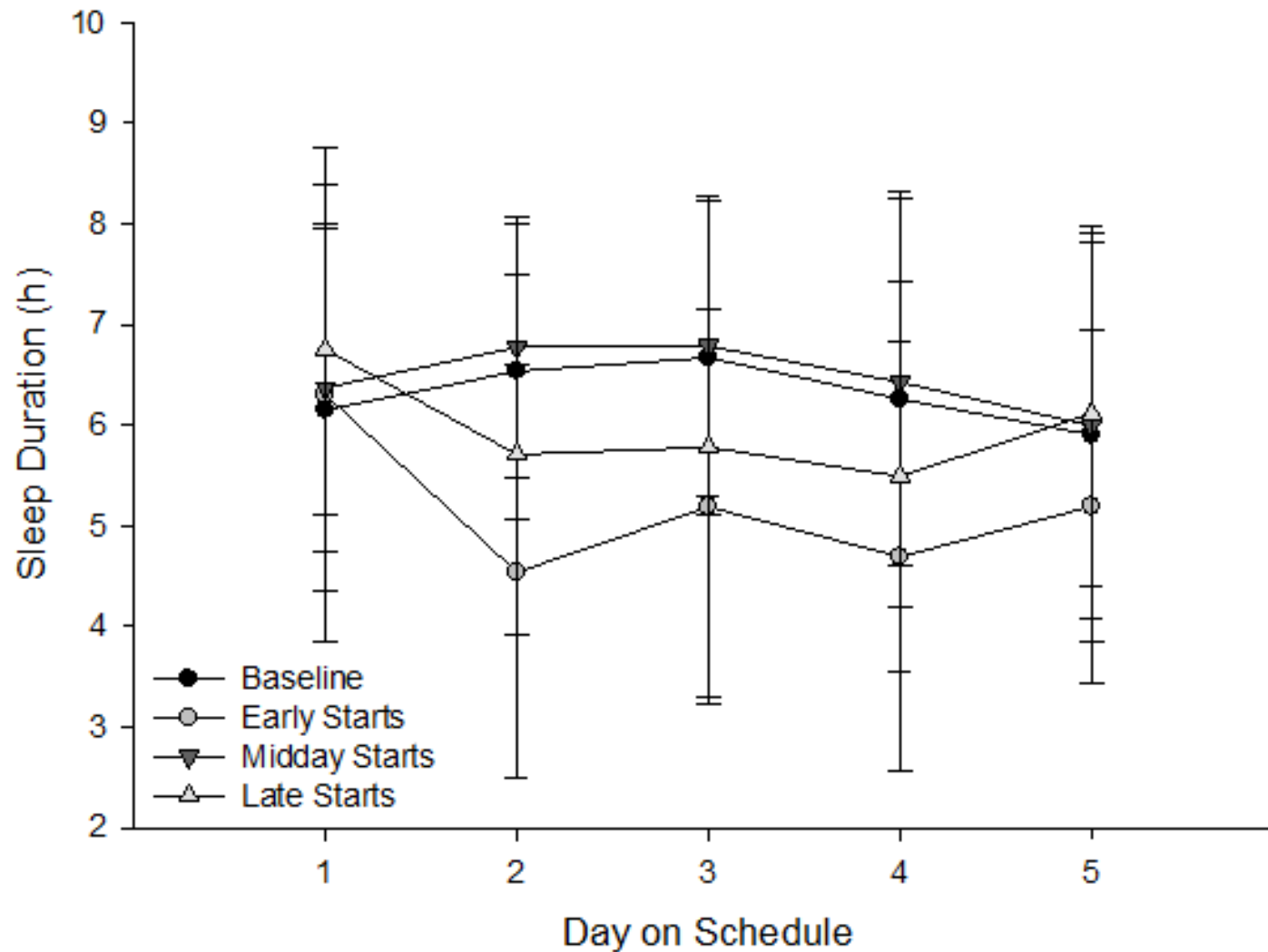

PVT Performance Varies by Duty Start Time

	n	Mean Reaction	Response	Mean Lapses
	(participants)	Time (ms, SD)	Speed (SD)	> 500 ms (SD)
Baseline (ref.)	38	236 (48)	4.84 (0.61)	3.1 (4.1)
Early	40	257 (70)**	4.63 (0.66)**	4.4 (5.4)**
Midday	39	261 (62)**	4.56 (0.66)**	4.7 (5.1)*
Late	38	266 (64)**	4.51 (0.63)**	4.7 (5.0)**
Rest days	40	249 (56)	4.69 (0.62)	4.0 (4.5)

Performance Varies by Day on Schedule

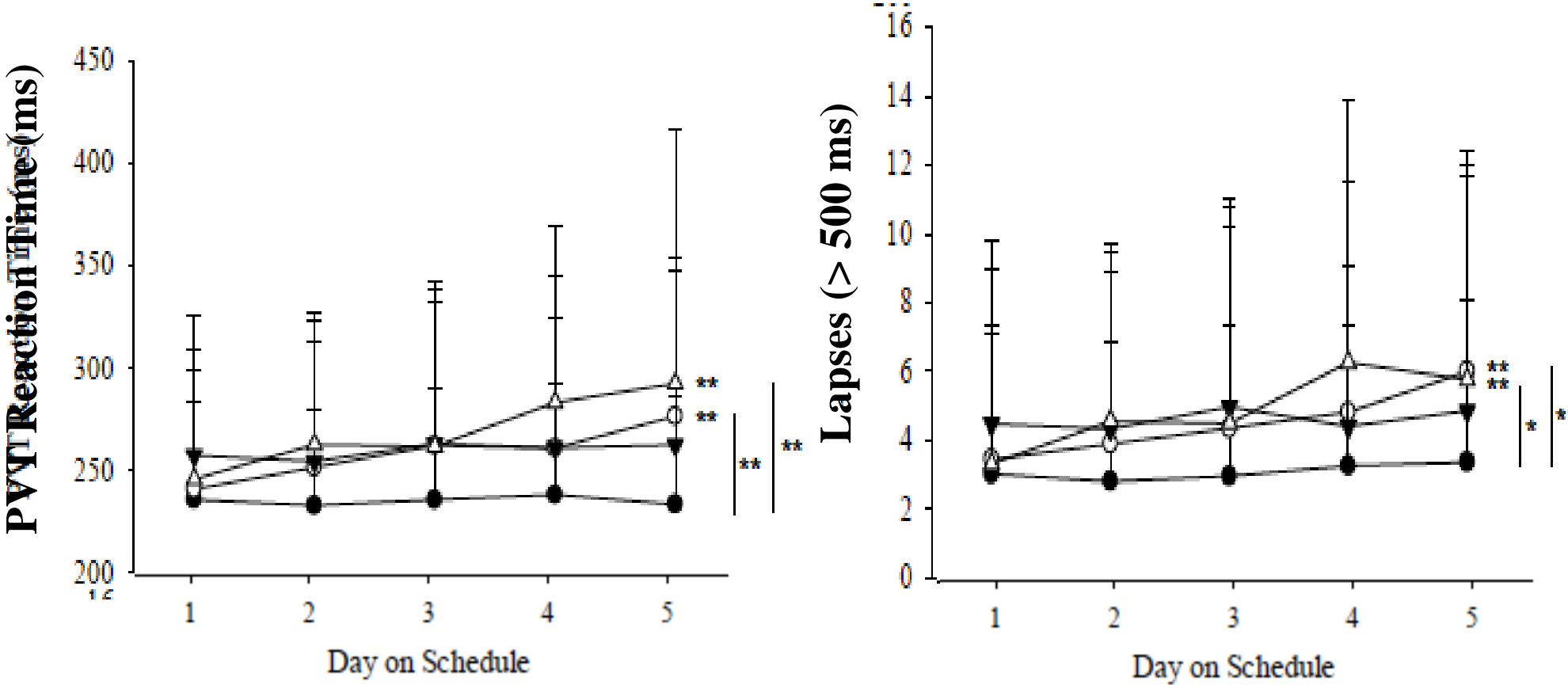

Circadian Phase Shifts According to Schedule

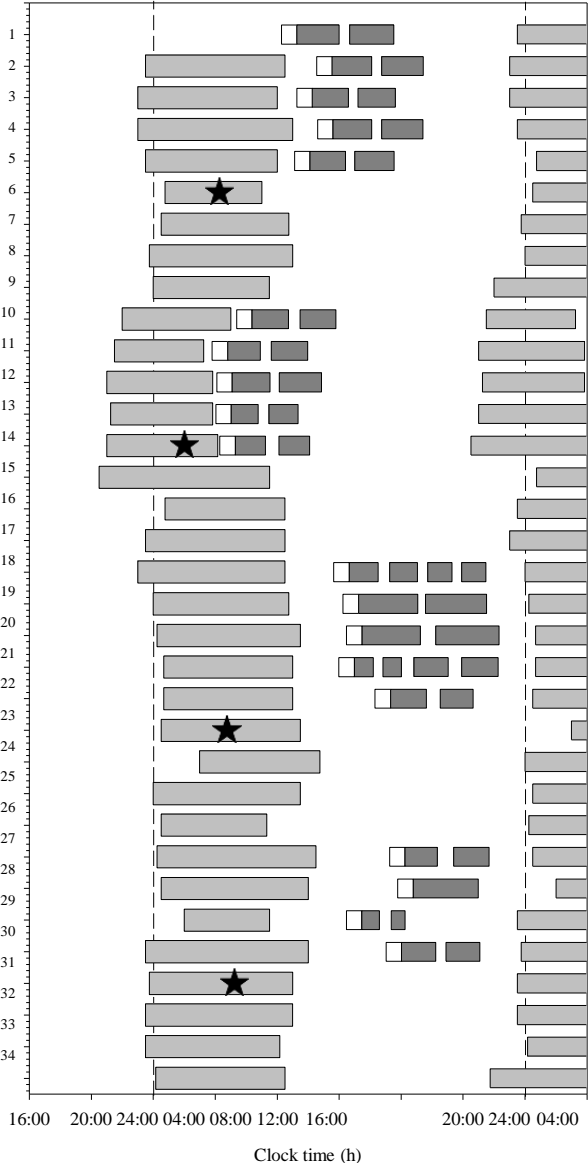
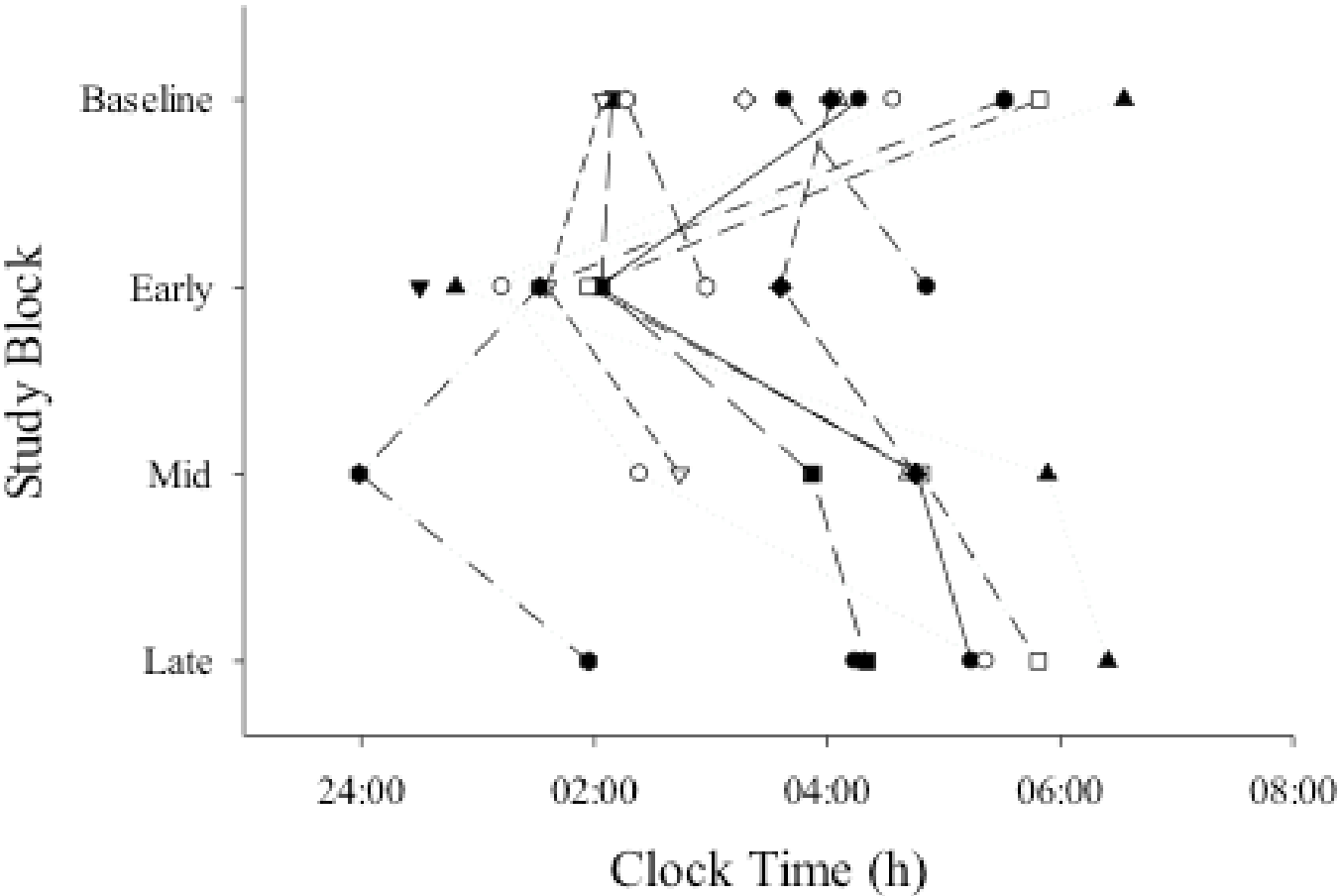

Summary of Findings: Short Haul Aviation Study

- Early starts associated with short sleep and poorer performance relative to baseline
- Late finishes associated with poorer performance relative to baseline
- Midday shifts with many sectors associated with poorer performance relative to baseline
- Circadian phase shifts vary by schedule start time

Next Steps: Can we improve sleep and circadian outcomes for early starts?

- Follow-up study (n = 66)
- Randomized controlled trial comparing blue light to placebo
- App, PVT, urine collection

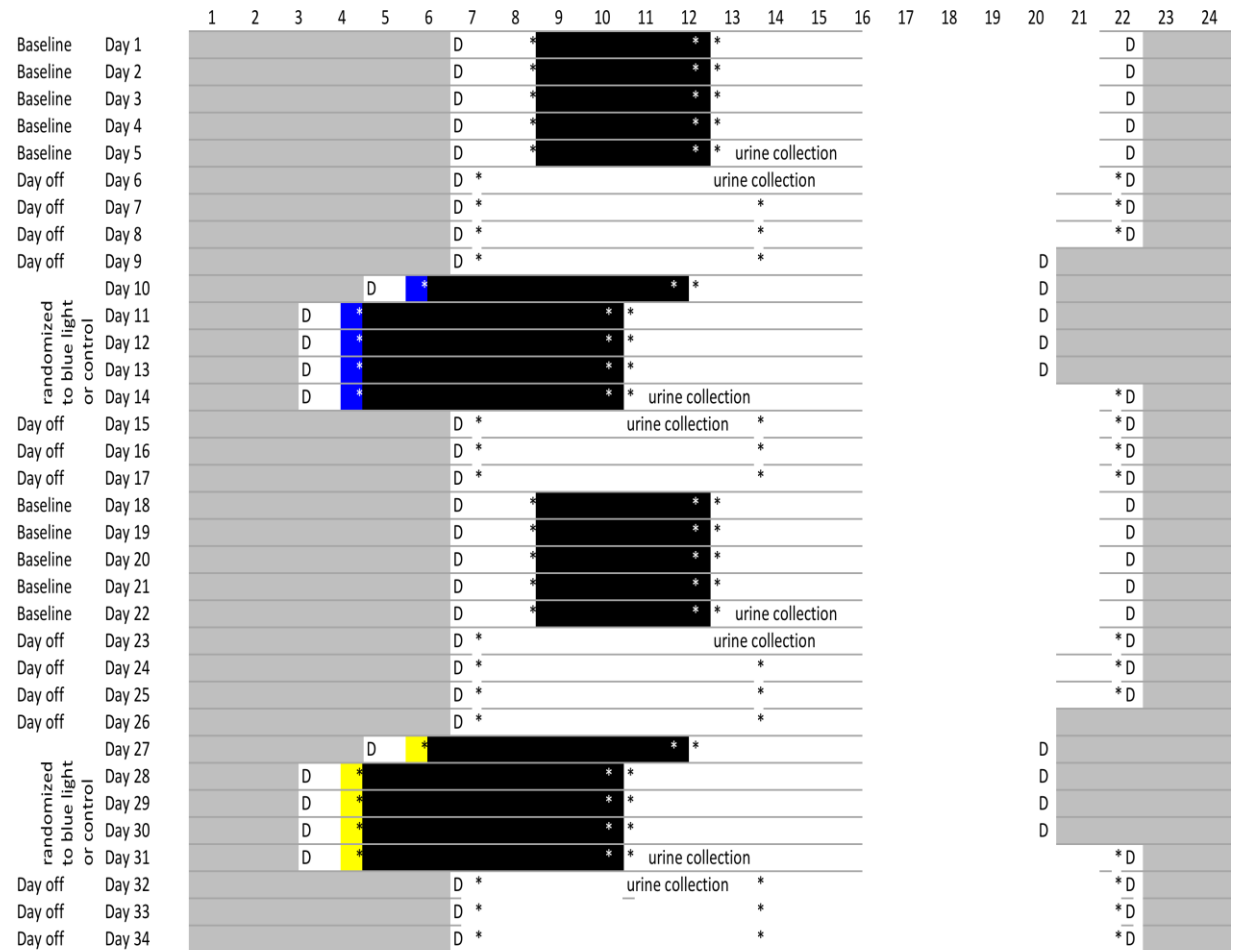

Key:
 = flight time
 = randomization to blue light
 = randomization to control
 = approximate sleep, note that participants choose their own sleep schedules

* = PVT and Samn Perelli D = Sleep diary

Example shows blue light first, however, the order will be randomized and counterbalanced, with each participant serving as his/her own control.



What do we know about sleep in space?



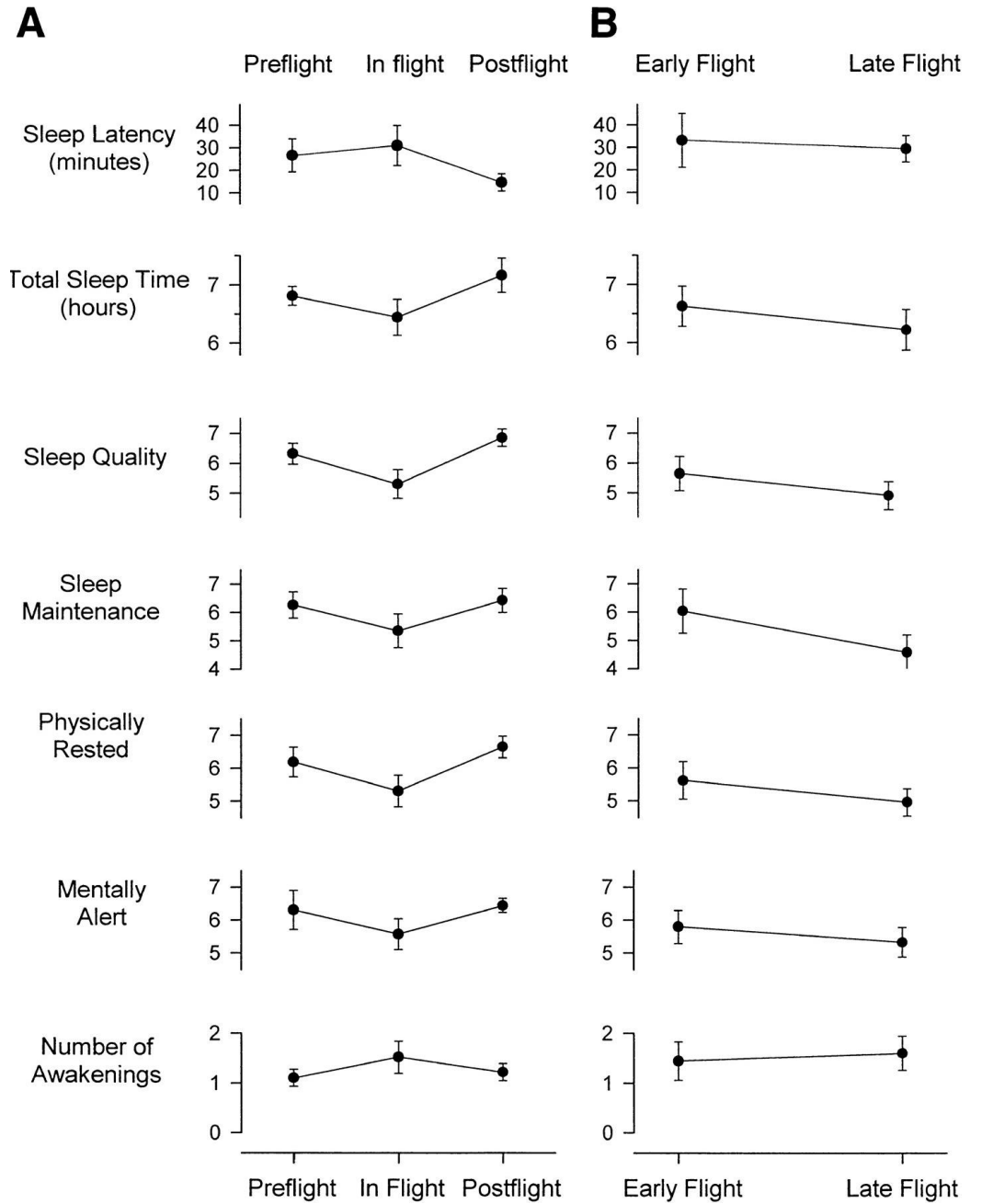
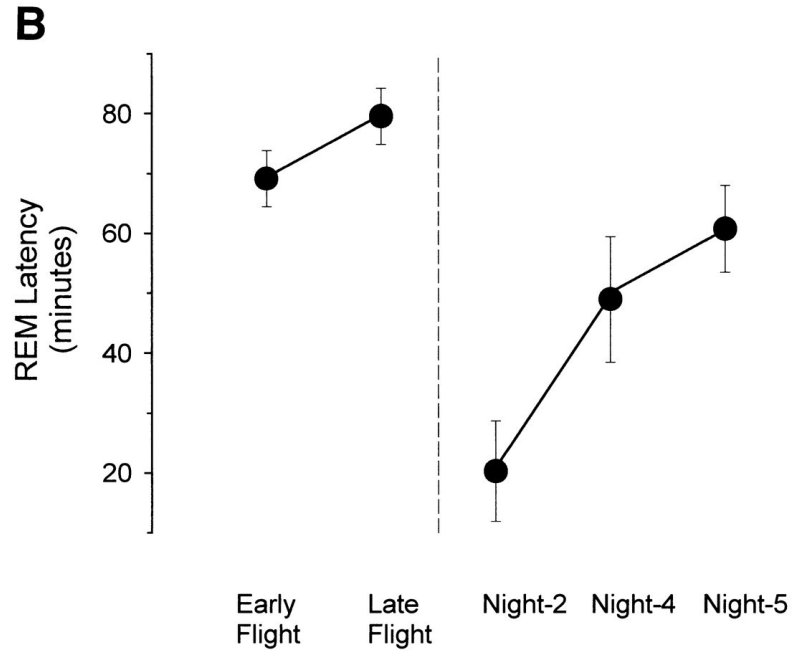
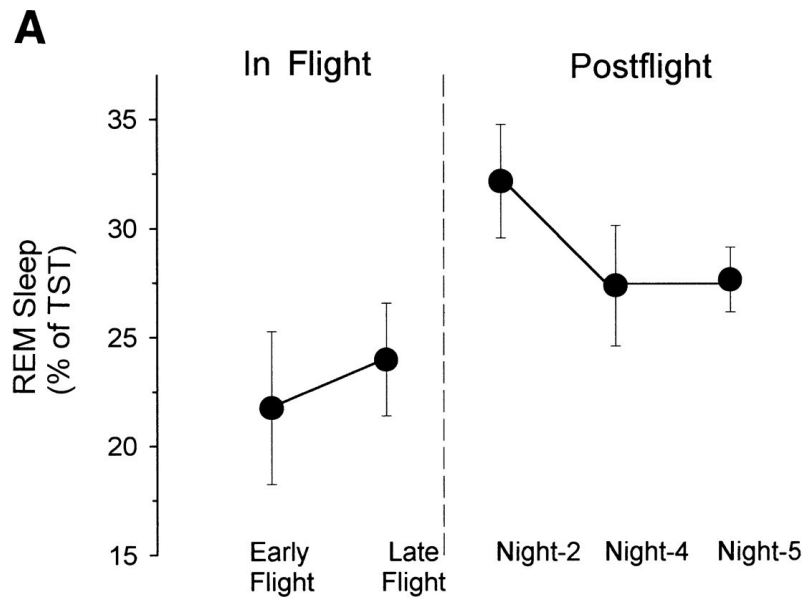



www.nasa.gov



CREW PARTICIPATION

N = 80 Missions

N = 60 Subjects

N = 26 Flights

4,175 Days of data collection

PREFLIGHT:

- 2 weeks at L-90
- L-11 through Launch
 - Shift in sleep/wake cycle

THROUGHOUT SPACEFLIGHT MISSION

POSTFLIGHT:

- R+0 through R+7



www.nasa.gov

Sleep Duration by Data Collection Period

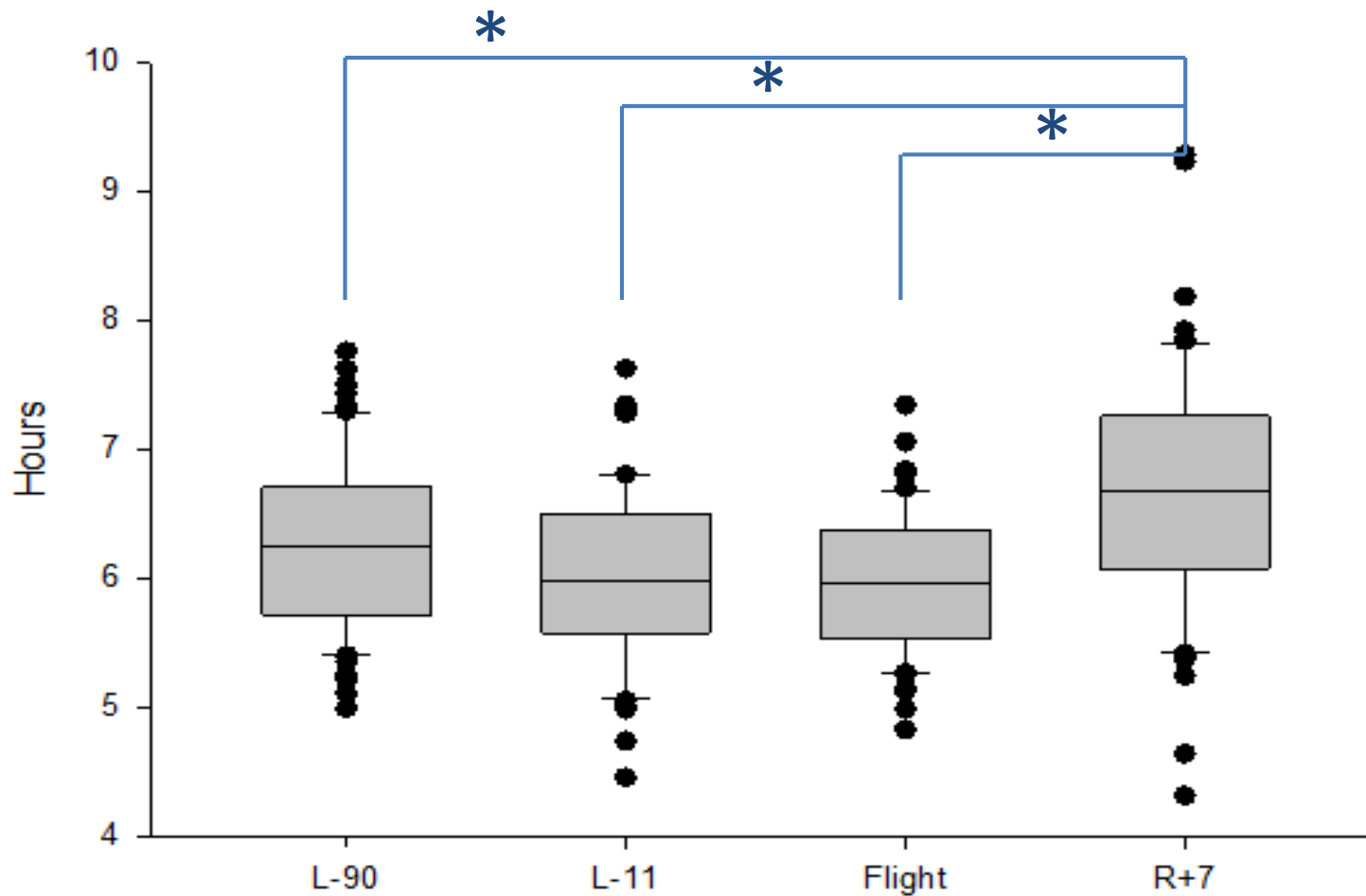

Houston we have a problem!

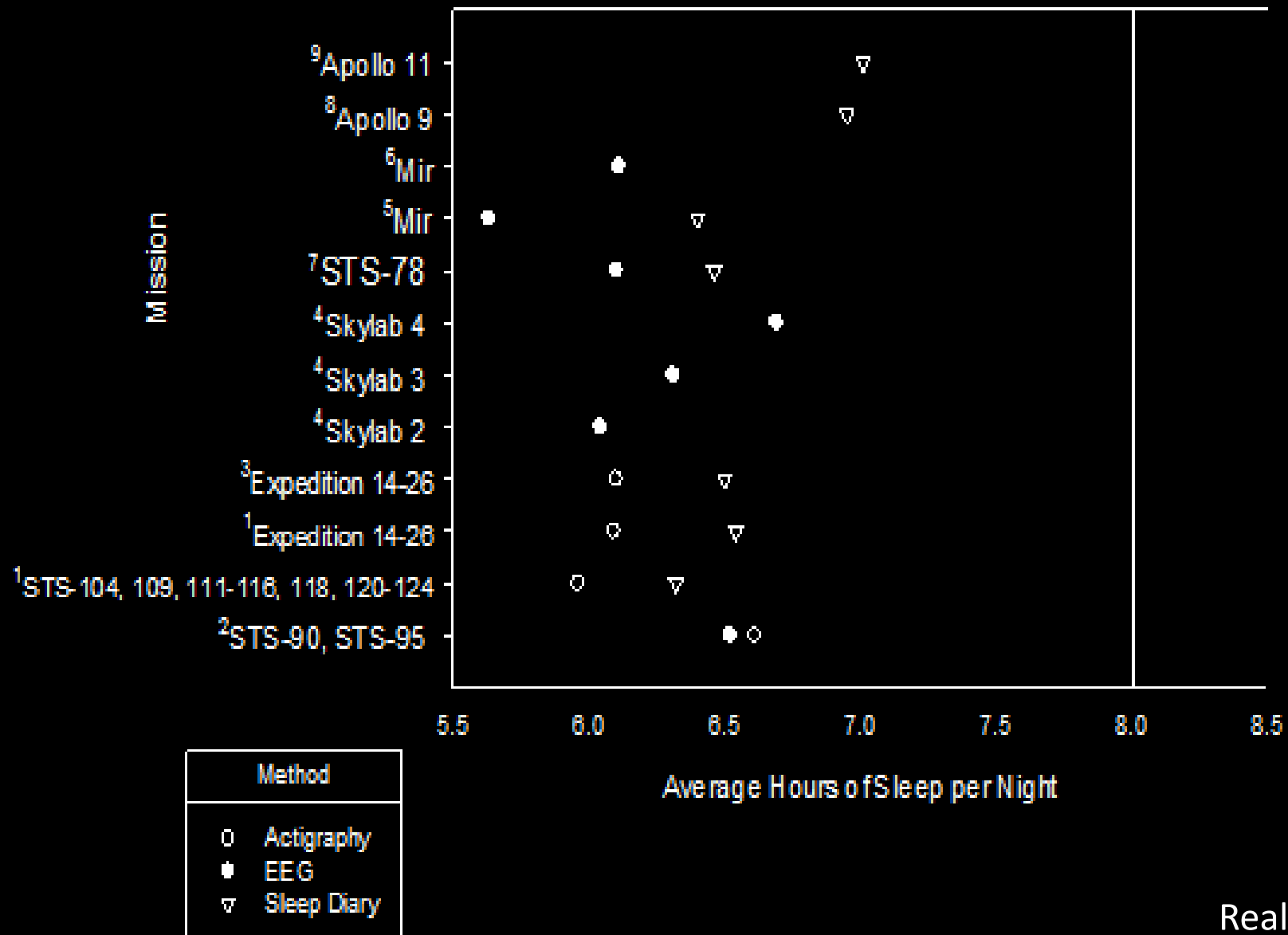

Why Can't Astronauts Sleep?

- Circadian rhythm/scheduling factors?
- High workload leading to acute or chronic sleep loss?
- Environmental Disruption?
- Microgravity?



Causes of Sleep Disturbance

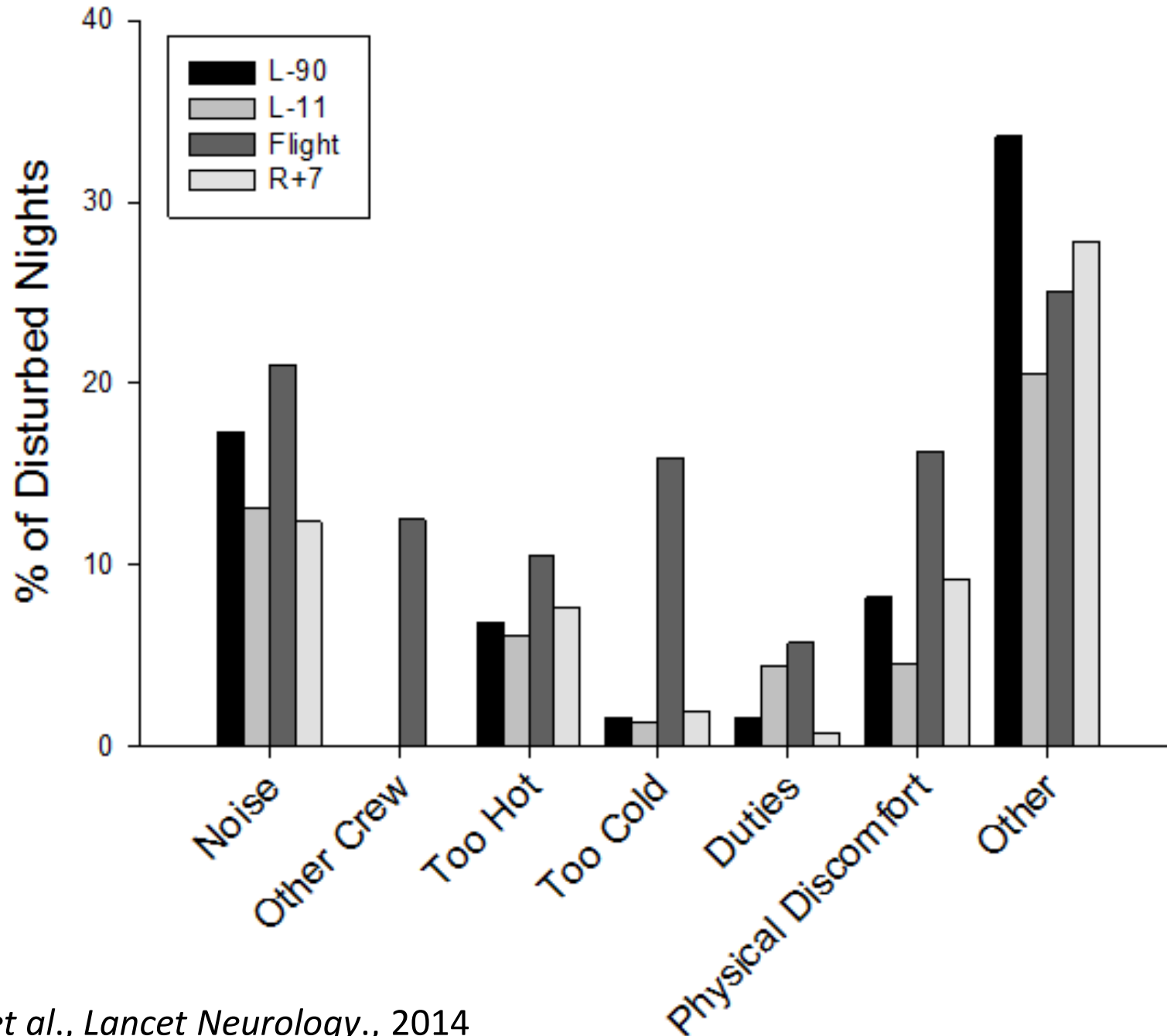



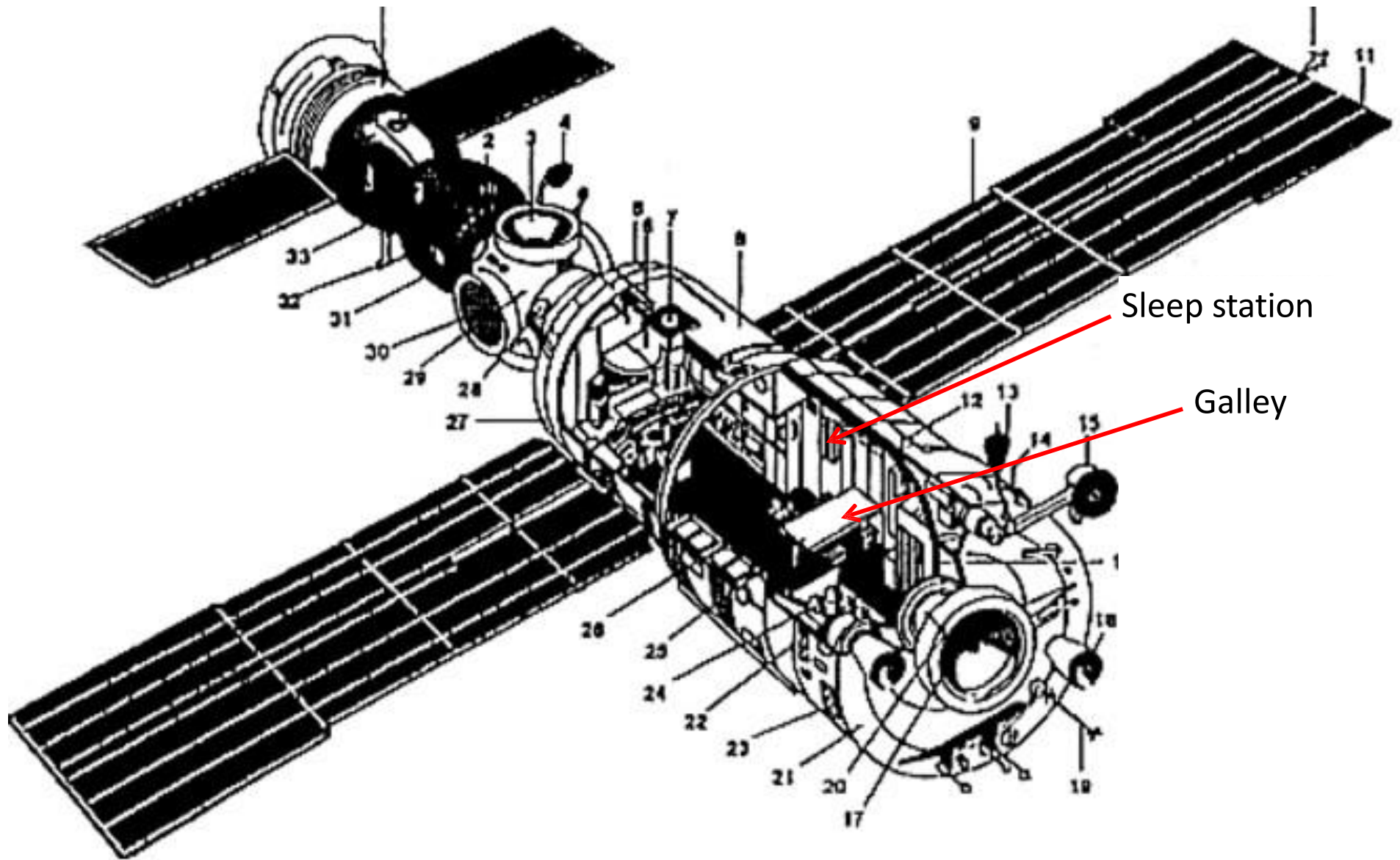

Core Module (Base Block)



Sleep Environment Matters

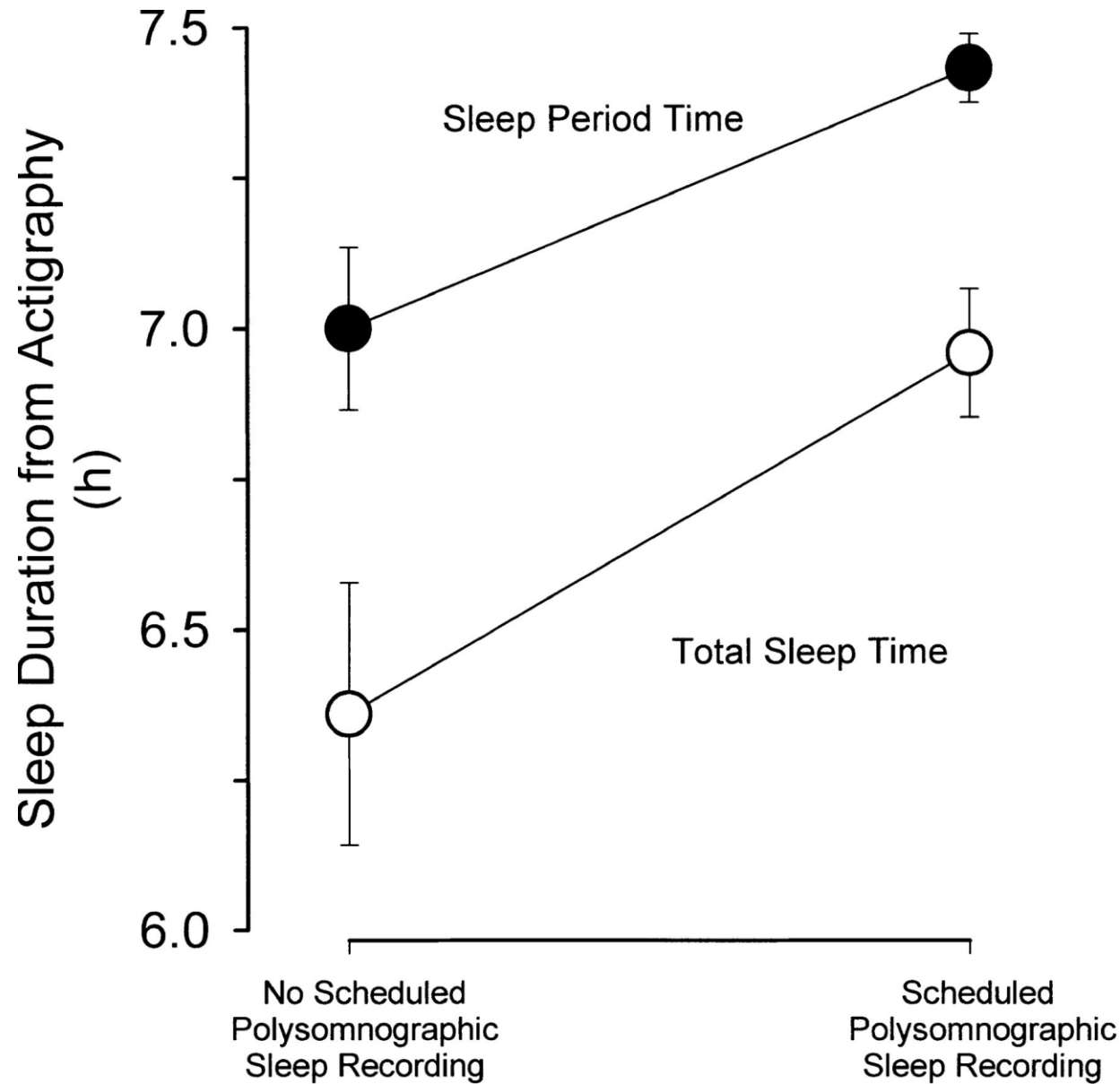

Why Can't Astronauts Sleep?

- Circadian rhythm/scheduling factors?
- High workload leading to acute or chronic sleep loss?
- Environmental Disruption?
- Microgravity?



High workload can bleed into scheduled sleep time during spaceflight



Dijk *et al.*, *AJP RICP.*, 2001

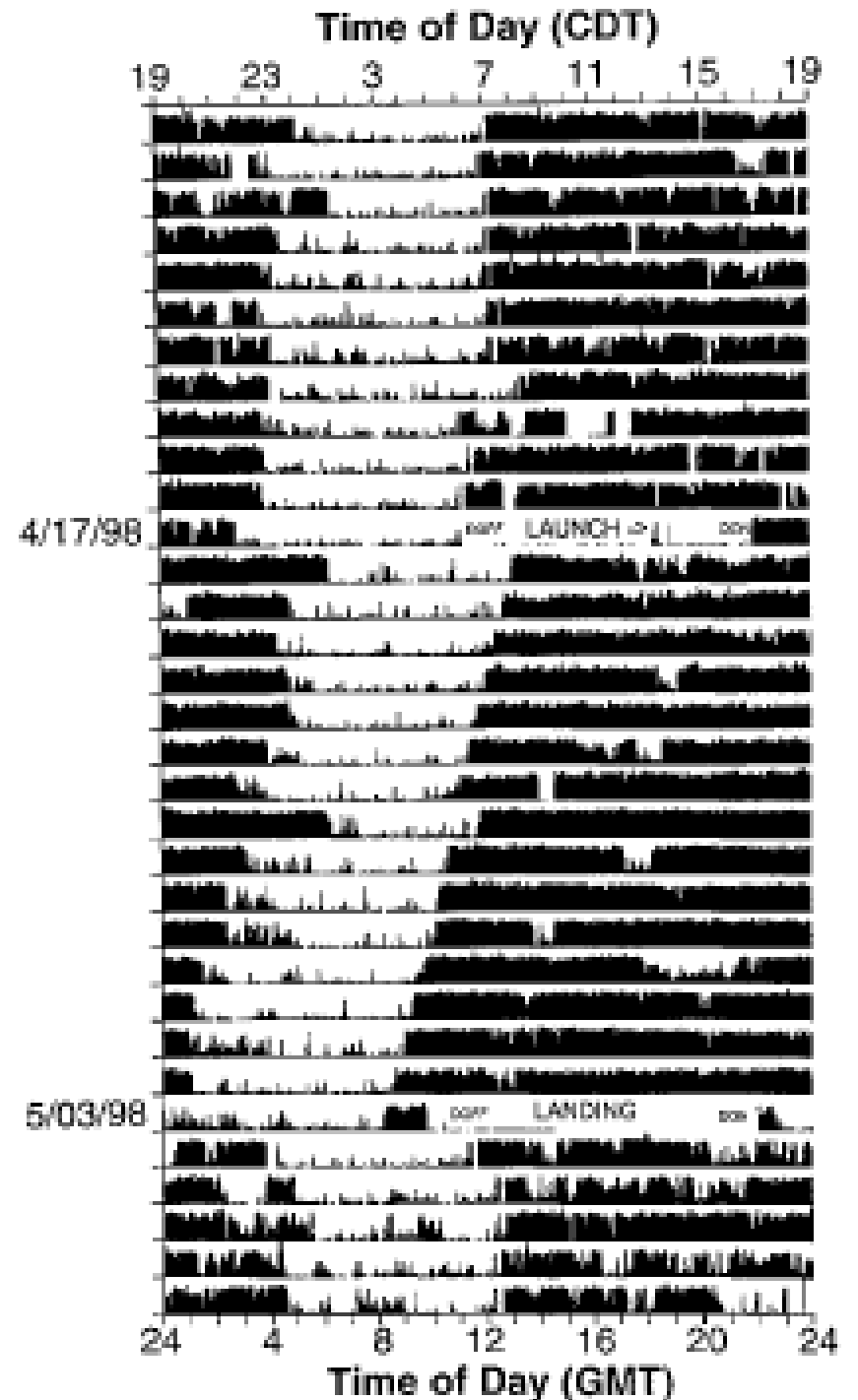



Why Can't Astronauts Sleep?

- Circadian rhythm/scheduling factors?
- High workload leading to acute or chronic sleep loss?
- Environmental Disruption?
- Microgravity?



Earth Conditions

On a 24-hour external light/dark cycle, the body's circadian clock remains properly synchronized (e.g., hormones like melatonin are released at the appropriate time).



Space Conditions

On the orbiter's 90-minute light/dark cycle, weak interior ambient light does not sufficiently cue the body's circadian clock, which may then become desynchronized (e.g., inappropriately timed hormone release).

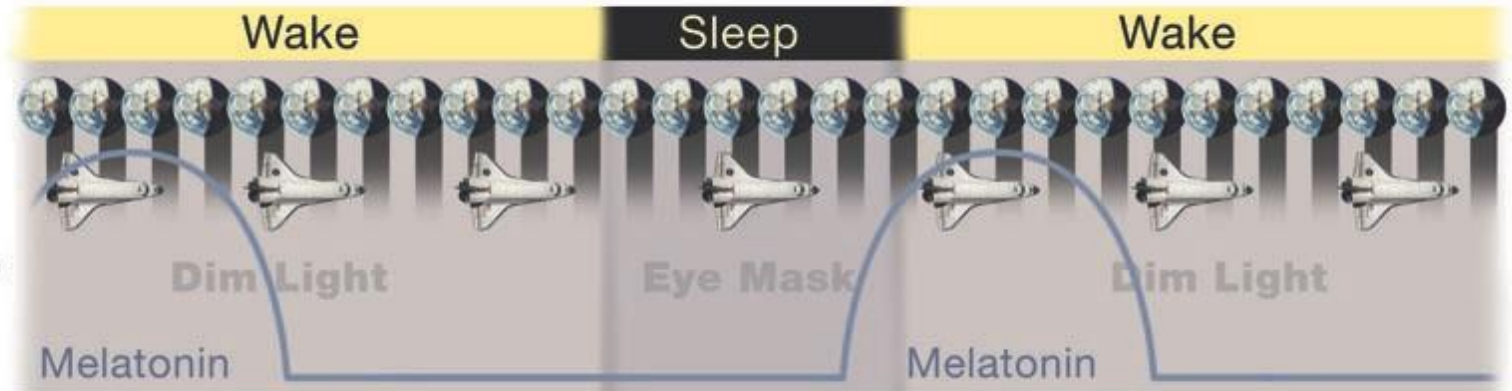

DRAFT 12-22-08

Sleep and Schedules on the Apollo Missions

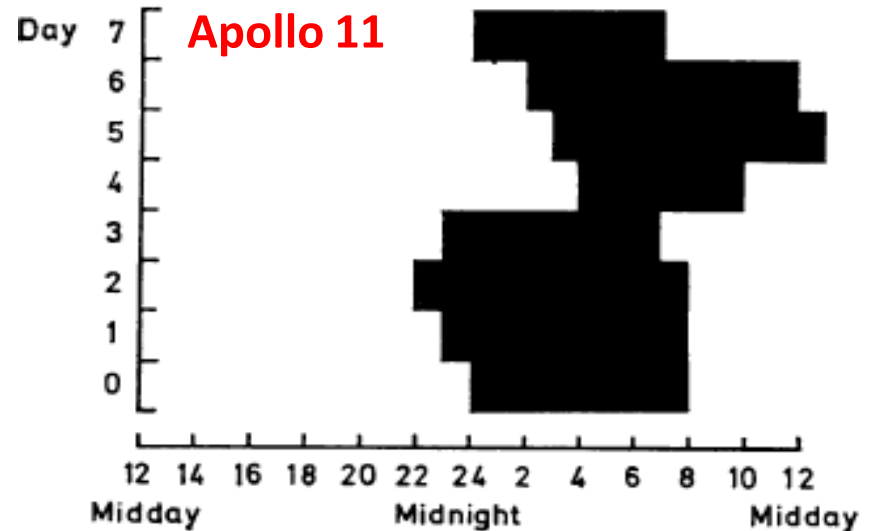
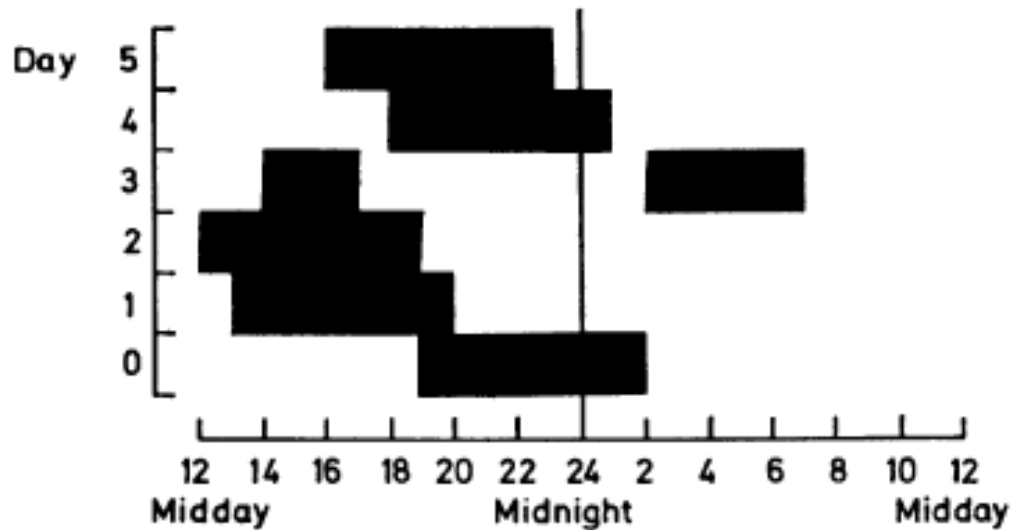
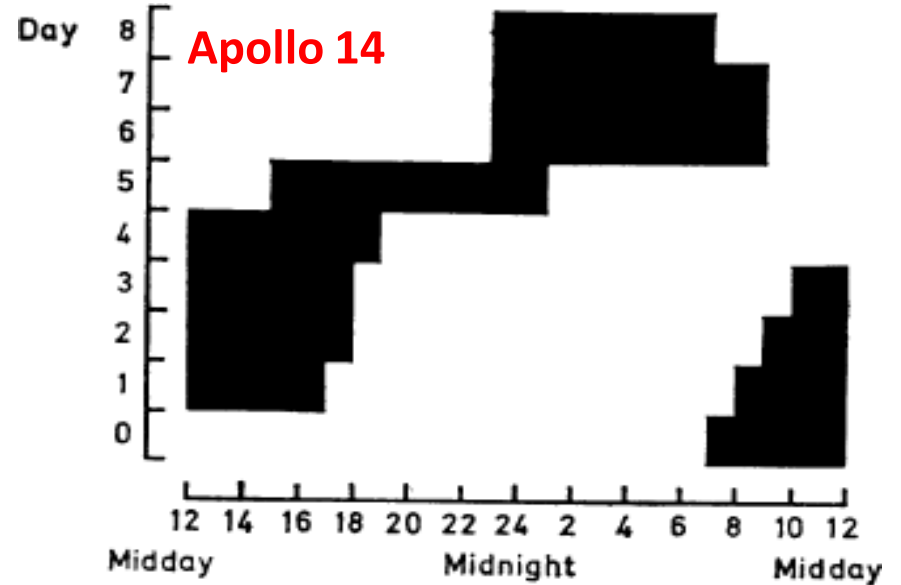
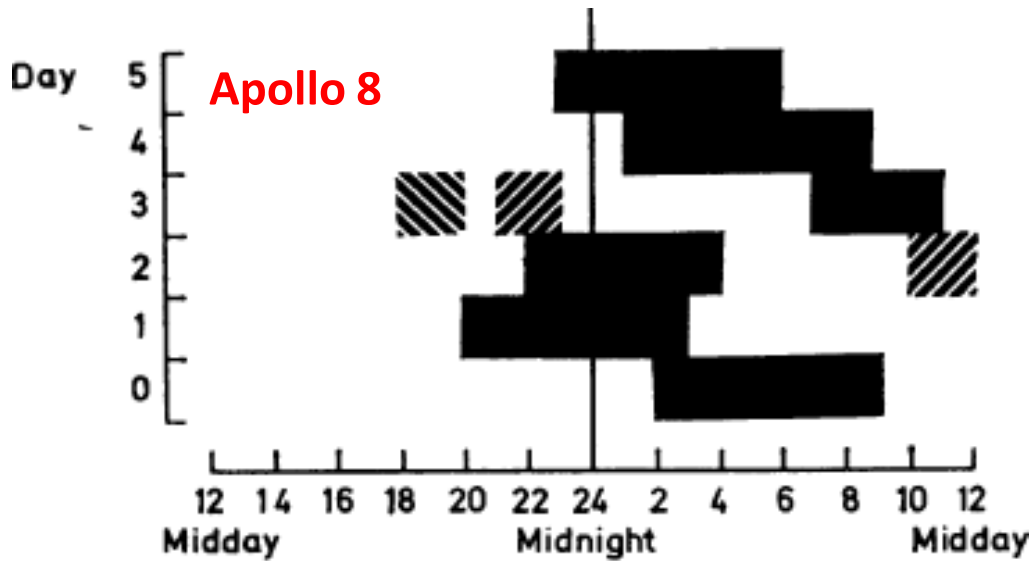

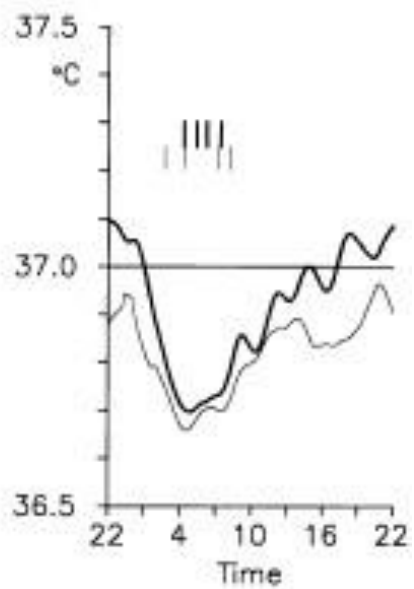
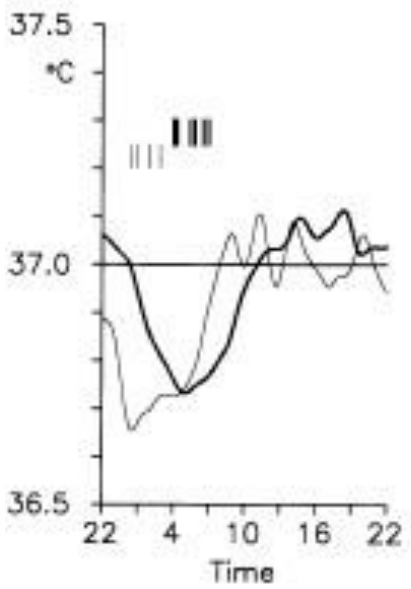
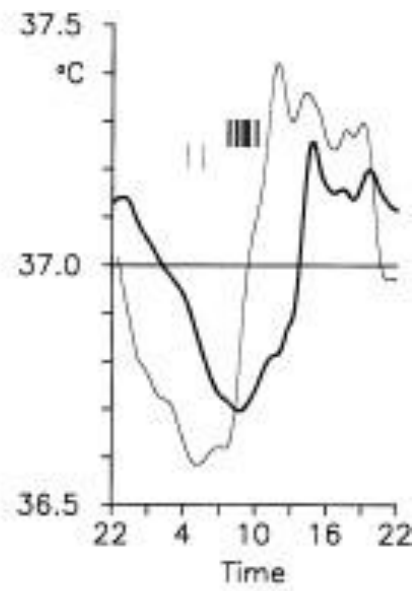
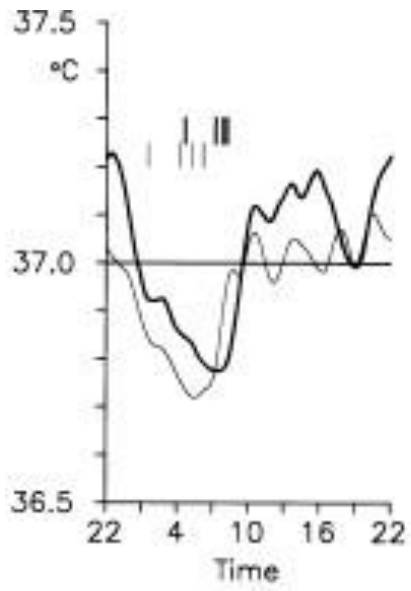

— Baseline — Mission



Gundel *et al*, *J. Sleep Res.*, 1997

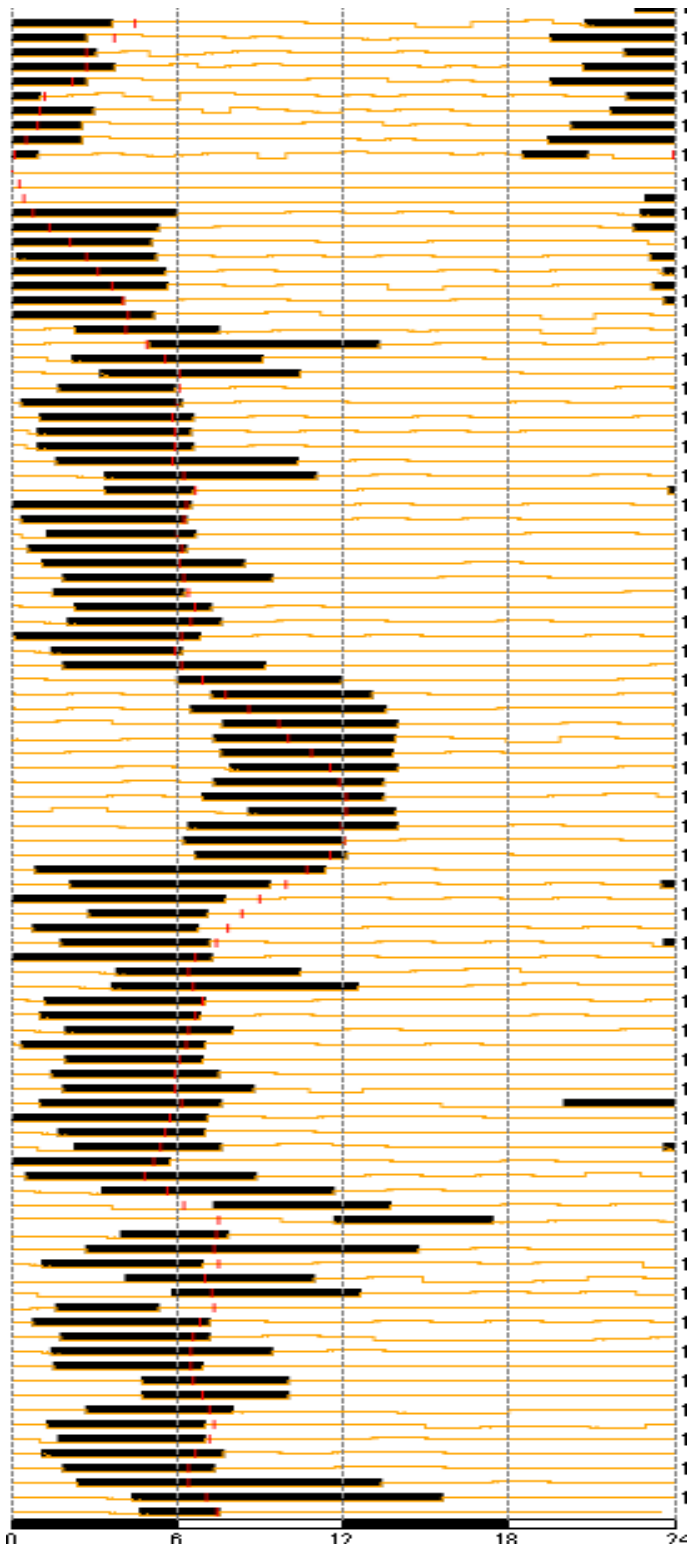



Effect of Predicted Circadian Alignment on Sleep Outcomes

	Aligned	Misaligned	
	Mean (SD)	Mean (SD)	p-value
Actigraphy Sleep Duration (h)	6.4 (1.2)	5.5 (1.4)	<0.01
Latency (m)	10.4 (15.1)	13.0 (24.9)	0.29
Number of Awakenings	1.7 (1.9)	1.8 (1.8)	0.36
Sleep Efficiency	89% (7%)	90% (7%)	0.18
Sleep Quality	66.8 (17.7)	60.2 (21.0)	<0.01
Alertness	57.9 (21.7)	53.5 (21.4)	0.14



A photograph of an astronaut in a white spacesuit working on the International Space Station (ISS) in space. The astronaut is positioned in the upper left, with one arm raised. Below and to the right, the complex structure of the ISS is visible, including various modules and solar panel arrays. The background shows the Earth's horizon with a blue atmosphere and a black sky.

How are Astronauts Coping with Sleep Loss?



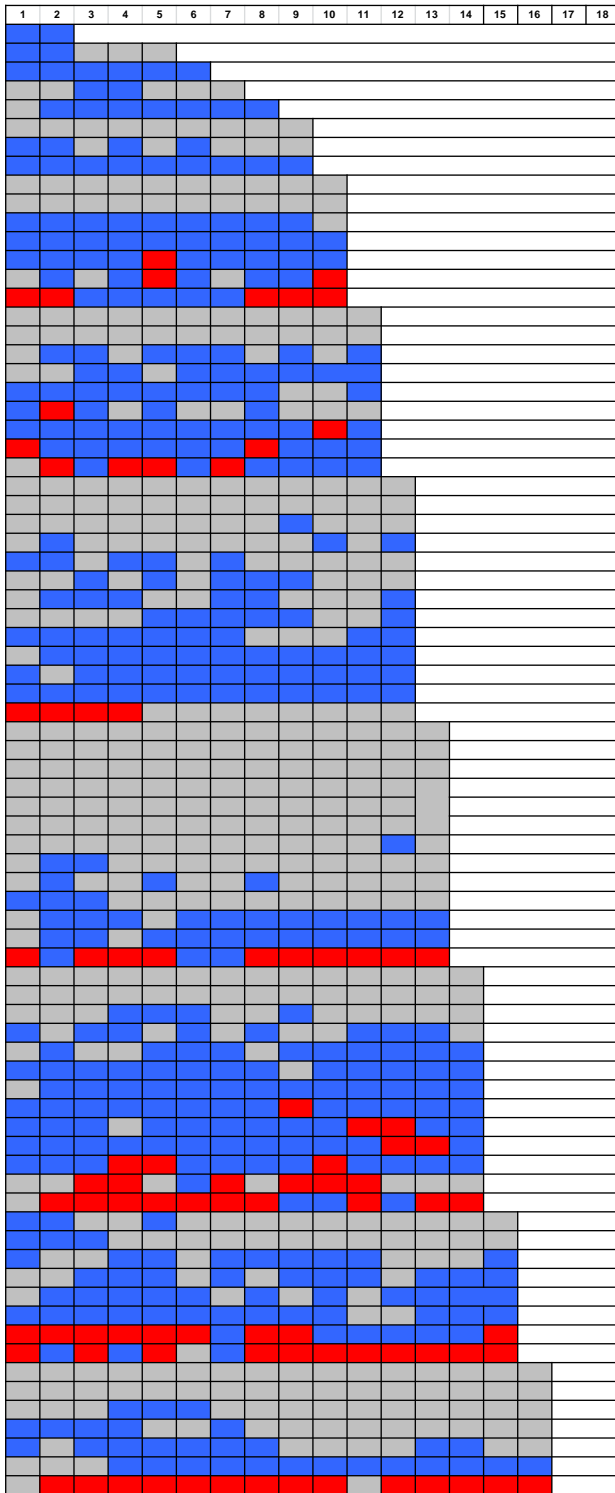

Sleep Medication Use by Subject and Flight Day

- 78% of participants reported using sleep medications some days
- Sleep medication was used on 52% of all nights in flight
- Participants used more than one dose on 18% of nights

Effect of Sleep Medication on Sleep Outcomes

	Nights without Medication	Nights with Medication	p value
Total Sleep (h)	5.82 (0.88)	6.00 (0.57)	0.21
Sleep Latency (m)	33.08 (26.91)	22.47 (16.53)	0.03
Sleep Efficiency	87% (7%)	88% (6%)	0.33
Sleep Quality	57.98 (20.39)	65.97 (13.91)	0.19
Alertness	61.5 (17.74)	66 (15.98)	0.19



What are we doing to help improve astronaut sleep outcomes?



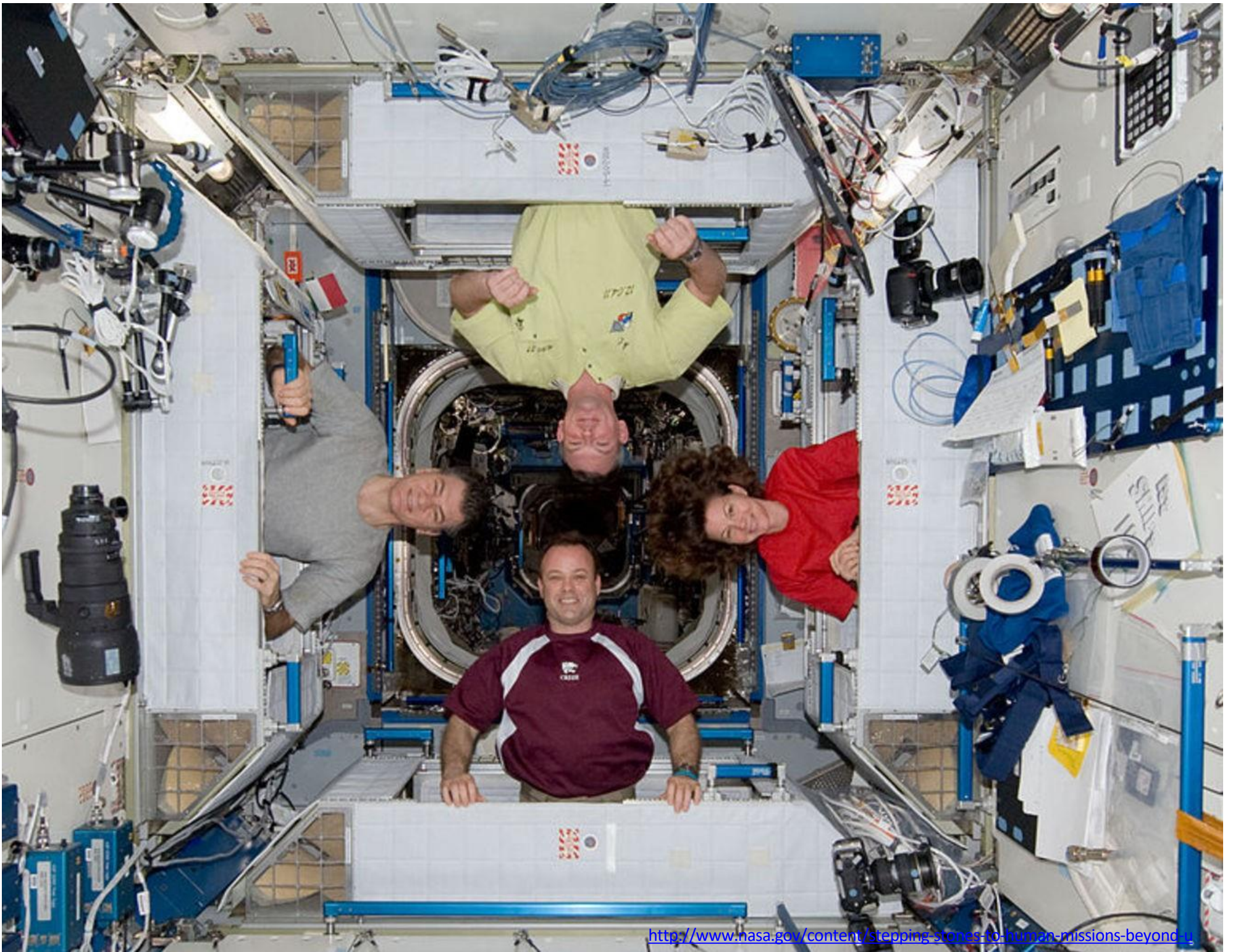



What's different about sleeping on Mars?





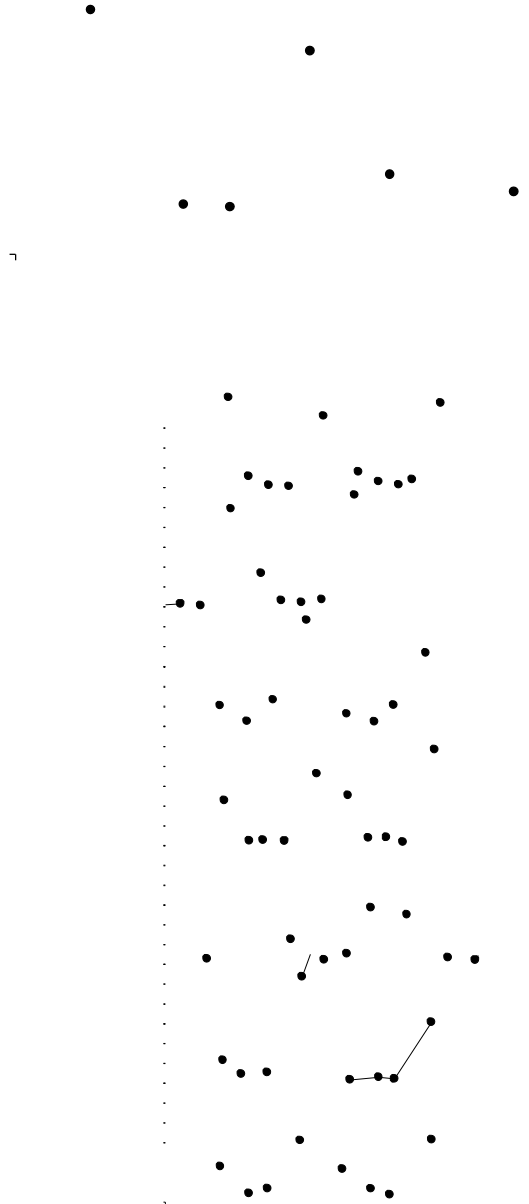

Where do we go from here?

- Conducting research for a changing aviation environment
 - Aircraft can fly farther
 - Increased autonomy
- Preparing for Mars
 - Psychosocial factors affecting sleep
 - Isolation and confinement for ~3 years
 - Evaluation of performance outcomes during spaceflight

Thank You!

Acknowledgements

Laura Barger PhD

Charles Czeisler PhD MD

Sean Benedix

Jason Sullivan

Lauren Leveton PhD

Alexandra Whitmire PhD

Kristine Ohnesorge

Curtis Kershner

Marty Bosch

Contact: Erin Flynn-Evans
erin.e.flynn-evans@nasa.gov

