

# Green Propellant Infusion Mission (GPIM) Thruster Valve Testing

Andrew T. Hynous<sup>1</sup>

*Trident Vantage Systems, Greenbelt, Md., 20770*

Eric H. Cardiff<sup>2</sup>, Dina Hoffman<sup>3</sup>, and Joseph T. Miller<sup>3</sup>

*National Aeronautics and Space Administration, Greenbelt, Md., 20771*

The Green Propellant Infusion Mission is a project in the NASA Technology Demonstration Missions that will perform a spaceflight demonstration of an AF-M315E propulsion system. The mission is led by Ball Aerospace & Technologies Corporation, with participation across industry and government. The spacecraft is based on the Ball BCP-100 bus, with an Aerojet Rocketdyne propulsion system. NASA Goddard Space Flight Center provides system testing and analysis of the flow within the AF-M315E propulsion system.

Performance testing was conducted to measure the rise and fall times of multiple 1 N and 22 N non-flight thruster valves provided by Aerojet Rocketdyne. The valves were driven at multiple head pressures and temperatures to approximate different flight conditions. Testing was conducted to observe how AF-M315E behaves in flight-like conditions.

The thruster valves were driven at set on/off-times and varying the driving pressure from 80 psig to 410 psig. The rise times and fall times were then analyzed by measuring the differential pressure from directly upstream and downstream of the valve and by measuring the current trace of the thruster valve.

## Nomenclature

<i>amp</i>	= Ampere
<i>C</i>	= Degrees Celsius
<i>DAQ</i>	= Data Acquisition
<i>GPIM</i>	= Green Propellant Infusion Mission
<i>GSFC</i>	= Goddard Space Flight Center
<i>LN2</i>	= Liquid Nitrogen
<i>N</i>	= Newton
<i>N/A</i>	= Not Applicable
<i>PSID</i>	= Pounds per Square Inch, Differential
<i>PSIG</i>	= Pounds per Square Inch, Gage
<i>P/N</i>	= Part Number
<i>s</i>	= Seconds
<i>S/N</i>	= Serial Number
<i>T1</i>	= Propellant Temperature Measured at Valve
<i>T2</i>	= Propellant Temperature Measured at Reservoir
<i>T3</i>	= Measured Valve Body Temperature

---

<sup>1</sup> Propulsion Engineer, Propulsion Branch (Code 597), GSFC

<sup>2</sup> Chief Engineer, Propulsion Branch (Code 597), GSFC

<sup>3</sup> Propulsion Engineer, Propulsion Branch (Code 597), GSFC

## I. Introduction

THE Green Propellant Infusion Mission (GPIM), led by Ball Aerospace & Technology Corporation, is a NASA Science Technology Mission Directorate funded Technology Demonstration Mission. The program is a collaboration between NASA, the Department of Defense, and industry partners designed to demonstrate the on-orbit capabilities of an AF-M315E-based propulsion system.<sup>1</sup> AF-M315E, developed by the Air Force and classified as a green propellant, is an ionic liquid exhibiting superior performance and reduced handling concerns when compared to the industry standard monopropellant, hydrazine. Due to its high specific impulse and density, AF-M315E has a significantly greater volumetric impulse than hydrazine, allowing for smaller propulsion systems and reductions in inert mass fraction.

To better define the flow characteristics of AF-M315E thruster valve assemblies for the GPIM mission, NASA Goddard Space Flight Center (GSFC) was tasked with measuring the performance of multiple 1 N and 22 N thruster valves. The primary area of focus were the measured rise and fall times, obtained via a differential pressure transducer connected up and downstream of the valve and the measured current trace from the valve. The propellant temperature was measured at the propellant reservoir and immediately next to the thruster valve. The temperature of the valve body itself was also measured.

## II. Data Acquisition and Testing Equipment

GSFC conducted AF-M315E testing with existing data acquisition (DAQ) hardware that had been used for previous AF-M315E testing.<sup>2</sup> Key testing equipment is detailed in **Table 1**. The differential pressure sensor and valve body thermocouple were tied into a National Instrument PXI platform (PXI-8109), allowing for rapid data collection and storage on the DAQ hardware. National Instrument LabVIEW virtual instruments were developed to receive sensor data and transmit commands to components. Additional thermocouples and thermistors were used with point-of-use displays and recorded manually. An oscilloscope was utilized to capture the current traces independently of the DAQ hardware.

**Table 1. Data Acquisition Hardware.**

Hardware	Part Number	Accuracy	Designations
Differential Pressure Transducer, Transmit; Omegadyne	PX409-500DWU5V [0 psid – 500 psid]	± 0.08% linearity, zero based best fit straight line	dP-G3
Thermocouple, Omega	TJ36-CASS-116(G)-12 [-270°C - (-1372°C)]	± 2.2 degrees Celsius	TC1
Dual Channel Arbitrary/Function Generator, Tektronix	AFG 3022B	N/A	N/A
Digital Serial Analyzer, Tektronix	DSA 71254	N/A	N/A
Amplifier, AC/DC Current Probe, Tektronix	TCPA300	N/A	N/A
Current Probe 30Adc, Tektronix	TCP312	N/A	N/A
Triple Output DC Power Supply, Hewlett Pacard	E3630A	N/A	N/A
Bipolar Power Supply, Kikusui	PBX 40-10	N/A	N/A

### III. Low Temperature Thruster Valve Testing

#### A. Testing Overview

Rise and fall time testing was conducted on six individual thruster valves while varying propellant temperature, commanded on and off times, and pressurizing gas head pressure. **Table 2** details the Part Number (P/N) and Serial Number (S/N) for the thruster valves utilized in testing. Two 1 N (P/N 40988-501) and four 22 N (P/N 40989-501) thruster valves were provided by Aerojet Rocketdyne to GSFC for this testing. Outlet flow tools were also provided to GSFC for capturing the propellant as it left the valve.

**Table 2. Thruster Valve Part and Serial Numbers.**

Description	P/N	S/N
1N Valve (Non-Flight)	40988-501	0001
1N Valve (Eng. Unit)	40988-501	0002
22N Valve (Eng. Unit)	40989-501	0001
22N Valve (Eng. Unit)	40989-501	0002
22N Valve (Non-Flight)	40989-501	0004
22N Valve (Non-Flight)	40989-501	0006

The temperature measured at the propellant reservoir (T2) was varied from -17.3 C to 17.5 C, which resulted in a propellant temperature measured at the valve (T1) that varied from -5 C to 24.3 C. For a series of tests conducted with a 1 N thruster valve (P/N 40988-501 S/N 0001), the thruster valve body was heated and cooled with the measured thruster valve body temperature (T3) recorded as -7.8 C to 51.3 C. The commanded on and off times for the valve pulse were varied from 0.015 s to 0.5 s and 0.15 s to 24.5 s, respectively.

Testing was conducted in three phases and **Table 14** through **Table 17** of **Appendix A** detail the commanded on and off time, the specified reservoir head pressure, and the available temperature ranges of the propellant. **Figure 31** in **Appendix C** provides a schematic of the testing apparatus. The first phase of testing was focused on variability in rise and fall response times, as measured with the differential pressure transducer. The thruster valves were actuated over a wide range of commanded on and off times through multiple head pressures. The temperature of the propellant was held as constant as possible through the testing with a 1 N thruster valve. The second phase of testing compared the rise and fall times from the differential pressure transducer and the oscilloscope measured voltage and current. The 1 N thruster valve was actuated with a constant commanded on and off time, while the propellant reservoir temperatures were varied. This data also included temperature measurements of the thruster body temperature while heating and cooling the thruster valve. The third phase of testing focused on variability between the provided thruster valves with constant commanded on and off times and varied temperatures for each 1 N and 22 N valves. A more detailed analysis follows in the adjacent sections and the general results from analysis are presented in **Figure 32** through **Figure 124** in **Appendix D**.

## B. Analysis Methodologies

Testing throughout the experiments utilized isolated power supplies, modulated pulse width function generators, an oscilloscope for measuring the current trace, and pressure and temperature measuring DAQ systems. Since the pressure and temperature sensing DAQ was isolated from the valve actuating equipment and the oscilloscope, the first step in the analysis required locating the time at which the thruster valve opened and closed from the pressure trace. **Figure 1** highlights a short section of three pulses for a differential pressure trace for a 1 N thruster valve. The nomenclature employed is different from normal due to the data being based on the differential pressure transducer.

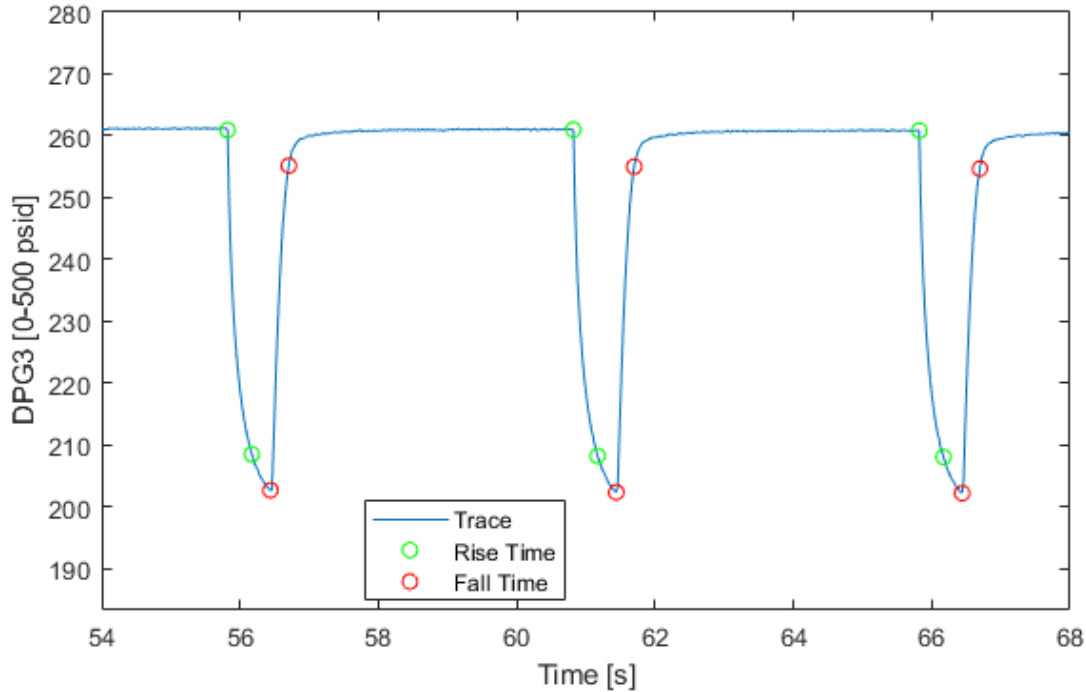

**Figure 1. Differential pressure trace.** Test data array: “032117 260psi 500ms 0.2Hz Run 1 pressure Transient.dat”. The locations highlighted by green represent the data point where the thruster valve opens and when the differential pressure reaches the 10% rise time value. The red highlighted locations represent the valve close data point and the 90% fall time value.

An algorithm was developed that repeatedly selected the data point at which the differential pressure began the initial drop from its steady state value. In **Figure 1** this initial thruster valve open point is at time 55.82 s. The algorithm also repeatedly selected the local minimum which represented the data point when the thruster valve closes. With the assumed thruster valve opening and closing data points, the 10% rise time and 90% fall time were calculated by setting the steady state, high differential pressure value as the 100% and the local minimum as the 0% for the calculations. **Table 3** details the thruster valve opening and closing time calculated for the three pulses shown in **Figure 1**. The commanded on time and off time for these pulses was 0.5 s and 4.5 s, respectively.

**Table 3. Measured differential pressure pulse information for Figure 1.**

Valve Open		Valve Close		Calculated On Time [s]
Time [s]	Rise Time [s]	Time [s]	Fall Time [s]	
55.82	0.35	56.44	0.27	0.62
60.82	0.35	61.44	0.26	0.62
65.82	0.35	66.44	0.26	0.62

As can be seen in **Table 3**, the algorithm successfully captured the total period of 5 s for this data set, but the calculated on time at the close of the thruster valve was 0.62 s. This is longer than the commanded on time of 0.5 seconds. What is of interest is that this lag remains nearly constant for this duty cycle. The calculated pulse to pulse period and calculated on time are the key parameters that were used to evaluate if the flow through the thruster valve had reached equilibrium, or steady state. These were the criteria used to determine whether a data set would be included in the results.

Integrating the voltage and current trace data measured independently by an oscilloscope was the next step of analysis. When utilized, the oscilloscope measured the voltage and the current of individual data pulses triggered by the change in voltage measured from the function generator and power supply for the actuation of the thruster valve. These individual pulses were then combined in sequence into a single data file for comparison to the differential pressure traces for each series of thruster valve pulses.

The oscilloscope, between pulses, does not store the measured voltage and current. Over the course of the data set, this leads to a lag between the oscilloscope measured voltage and current data and the differential pressure transducer data. The algorithm developed for the analysis of the voltage and current data corrects this lag by adjusting the trigger data point for the oscilloscope to the algorithm selected differential pressure trace data point when the thruster valve opens. **Figure 2** below provides an example of this differential pressure, voltage and current trace alignment. The voltage trace indicates the square wave nature of the commanded on pulse for actuating the thruster valve and the corresponding current trace. The noise of the measurement system masked the voltage and current trace indicators of the poppet travel normally associated with solenoid valves. A similar analysis to the one done to the differential pressure trace was implemented on the existing current trace. The missing gap of data between the pulses is then ignored in the analysis.

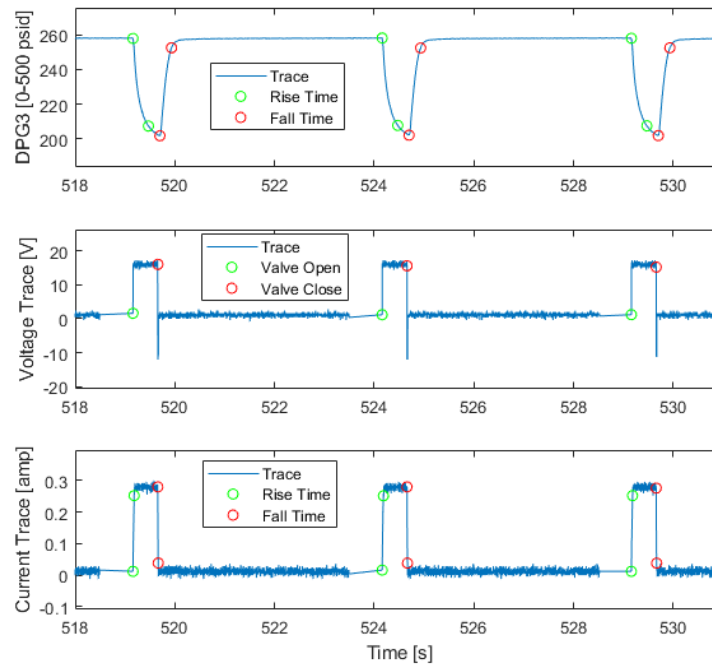

**Figure 2. Differential pressure trace and companion current trace.** Data set array: “032117 260psi 500ms 0.2Hz Run 2 pressure Steady State.dat”.

A separate 90% rise time and 10% fall time analysis was then conducted on the current traces. This analysis sets the low current steady state value to be 0% and the high current value to be 100%. The algorithm then calculates when the current crosses the 90% and 10% values. **Table 4** and **Table 5** present the pulse information, differential pressure and current traces, for **Figure 2**. Comparing **Table 4** to **Table 5**, both sets of data have a commanded on time of 0.5 s and an off time of 4.5 s. The rise time, fall time, and time to valve close can be considered consistent with the

differential pressure data from **Table 4**. The measured time at valve close is 0.54 s, still greater than the commanded on time; the rise and fall times are comparable to those in **Table 3**.

**Table 4. Measured differential pressure pulse information.**

Valve Open		Valve Close		Calculated On Time [s]
Time [s]	Rise Time [s]	Time [s]	Fall Time [s]	
519.16	0.31	519.70	0.23	0.54
524.16	0.31	524.70	0.23	0.54
529.16	0.31	529.70	0.23	0.54

**Table 5. Measured current pulse information.**

Valve Open		Valve Close		Calculated On Time [s]
Time[s]	Rise Time[s]	Time[s]	Fall Time[s]	
519.160	0.0227	519.6580	0.00789	0.498
524.160	0.0252	524.6580	0.00972	0.498
529.160	0.0241	529.6580	0.00842	0.498

Comparing **Table 4** to **Table 5**, as stated previously, the time at which the valve opens has been synced together, but the valve close times are different. The current trace data, **Table 5**, for the testing shows that the measured time to valve closure is right at 0.5 s after the valve opens, and this is consistently shorter than the measured time to closure for the differential pressure trace. This relation held throughout testing.

The final step in integrating the testing data was incorporating the temperature readings from the point of use thermistor and thermocouple. This was done manually by the use of the DAQ system timer and then creating tables of the propellant temperature measured at the valve (T1) and the reservoir propellant temperature (T2) and then interpolating and integrating the temperature data into the test data arrays.

### C. Phase 1 Testing

Initial testing was conducted on a provided 1 N valve (P/N 40988-501, S/N 0001). During this phase of testing, the reservoir head pressure was operated at 3 distinct pressures: 80, 150, and 280 psig. The testing regimes conducted in phase 1 are detailed in **Table 14** of **Appendix A**. The general results for the 1 N thruster valve testing of phase 1 are presented in **Appendix D**. These figures present the rise and fall time calculated from the differential pressure transducer traces against the propellant temperature measured at the valve (T1) and the reservoir propellant temperature (T2). These general results are listed according to pressure:

- 80 psig in **Figure 32** through **Figure 38**
- 150 psig in **Figure 44** through **Figure 50**
- 280 psig in **Figure 65** through **Figure 80**

The following figures present the relationship of interest for the differential pressure measured rise and fall times for the thruster valve. The rise, fall, and calculated on times were averaged for each commanded on and off time pair presented in **Table 6**.

**Table 6. P/N 40988-501 S/N 0001 average calculated on time and average measured rise and fall times for phase 1 testing.**

Pressure [psig]	On Time [s]	Off Time [s]	Calculated On Time [s]	Measured Rise Time [s]	Measured Fall Time [s]
80	0.05	0.95	0.200	0.149	0.672
	0.1	0.9	0.200	0.173	0.673
	0.1	1.9	0.200	0.177	1.344
	0.2	0.8	0.349	0.279	0.563
	0.5	0.5	0.585	0.501	0.358
150	0.015	0.985	0.050	0.045	0.621
	0.015	1.985	0.050	0.045	0.778
	0.02	0.98	0.097	0.047	0.652
	0.05	0.95	0.192	0.146	0.644
	0.1	0.9	0.250	0.190	0.610
	0.2	0.8	0.283	0.233	0.561
	0.5	0.5	0.600	0.498	0.356
280	0.02	0.98	0.100	0.091	0.282
	0.05	0.15	0.133	0.108	0.061
	0.05	0.95	0.171	0.134	0.309
	0.1	0.9	0.193	0.144	0.311
	0.1	1.9	0.210	0.157	0.325
	0.1	2.4	0.209	0.149	0.389
	0.1	3.9	0.192	0.133	0.298
	0.2	0.8	0.270	0.198	0.296
	0.5	0.5	0.600	0.396	0.336

The differential pressure measured rise time exceeded the commanded on time but not the calculated on time for all short duration duty cycles. The point at which the measured rise time falls below the commanded on time decreases at an inverse proportional rate to the rising reservoir head pressure. At shorter duty cycles, the head pressure does not have enough time to fully develop. **Table 7** presents the commanded on time and measured rise time values where this phenomenon is captured.

**Table 7. Measured rise time comparison to difference between calculated and commanded on time.**

Pressure [psig]	Commanded On Time [s]	Calculated On Time [s]	Measured Rise Time [s]
80	0.5	0.585	0.501
150	0.2	0.283	0.233
280	0.1	0.192 to 0.210	0.133 to 0.157

The difference between the commanded and calculated on times is a function of the fluid flow of the propellant through the thruster valve. In **Figure 3**, **Figure 5**, and **Figure 7**, the average differential pressure measured rise times are plotted against the commanded on time, respective to the reservoir head pressure. In **Figure 4**, **Figure 6**, and **Figure 8**, the average differential pressure measured fall times are plotted against the off time, again respective to the reservoir head pressure.

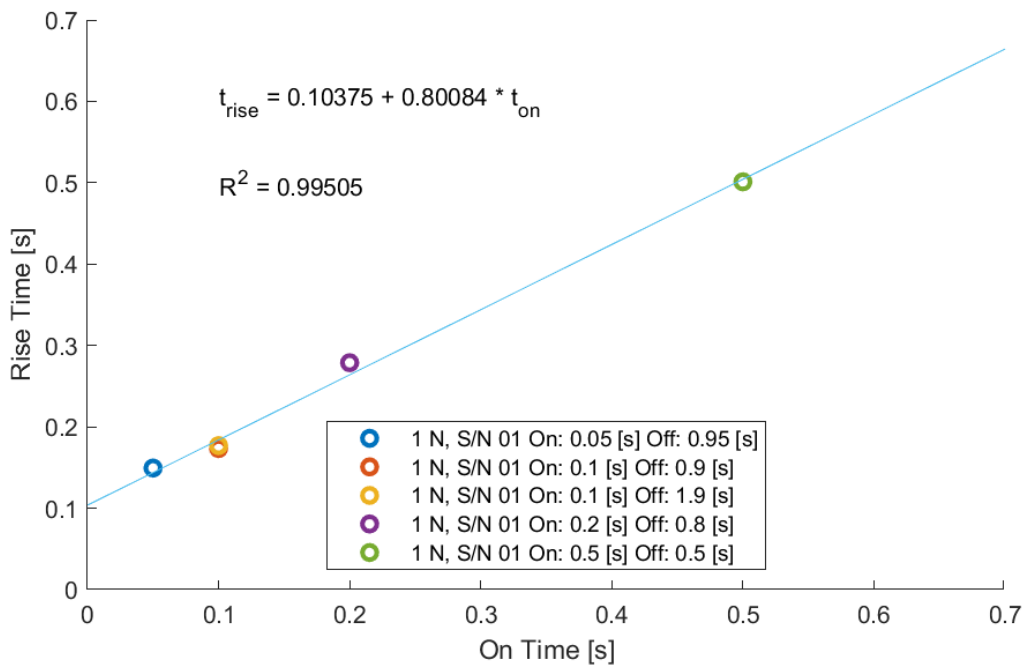

**Figure 3. Thruster valve average rise time as measured by the differential pressure transducer against the commanded on time for 1 N thruster valves at 80 psig reservoir head pressure.**

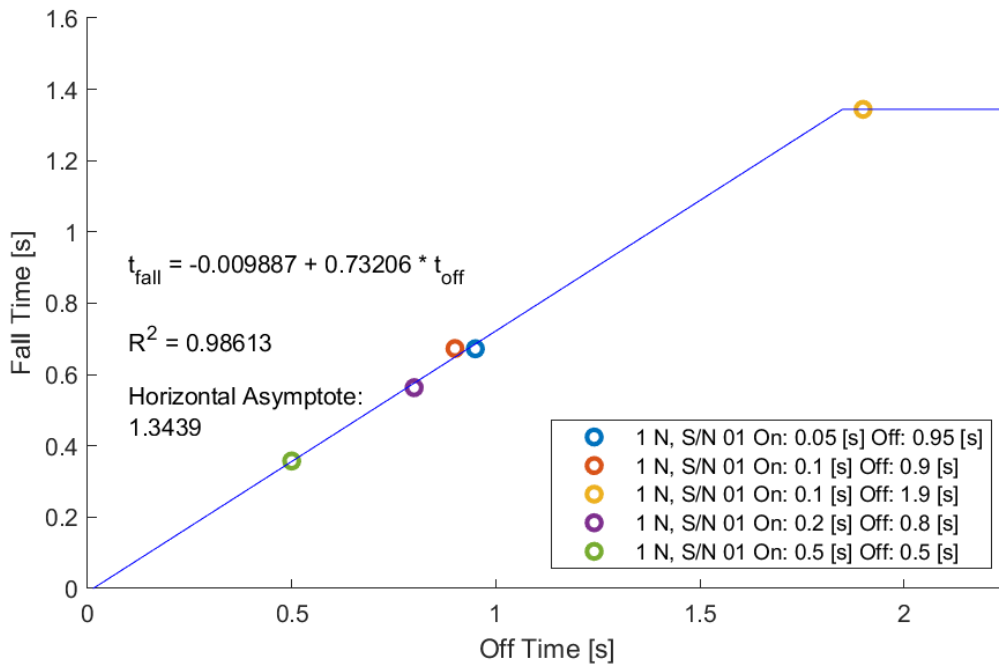

Figure 4. Thruster valve average fall time as measured by the differential pressure transducer against the off time for 1 N thruster valves at 80 psig reservoir head pressure.

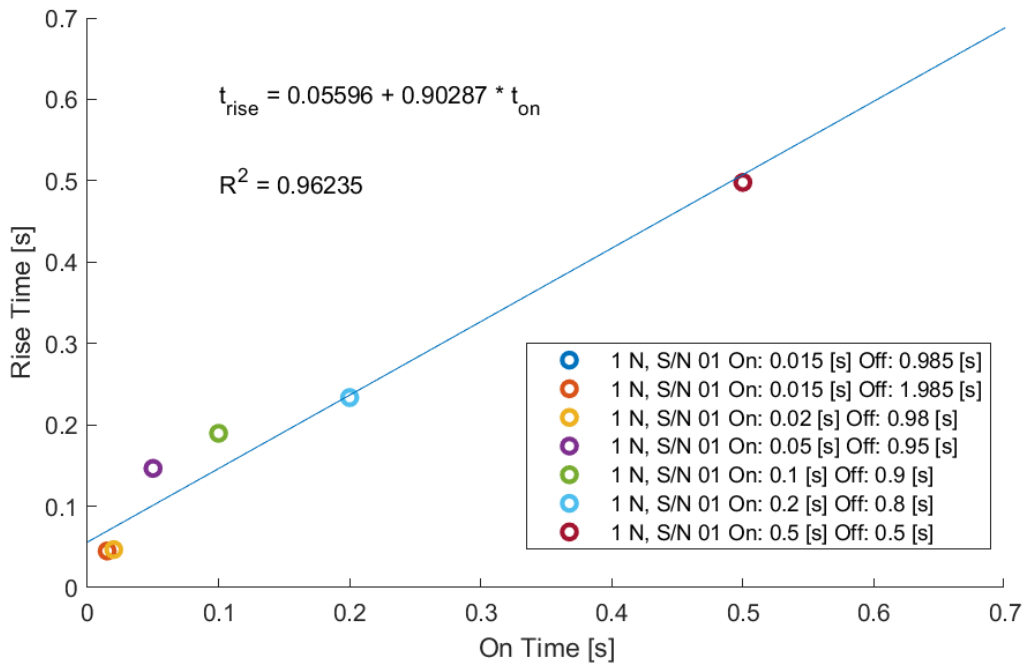

Figure 5. Thruster valve average rise time as measured by the differential pressure transducer against the commanded on time for 1 N thruster valves at 150 psig reservoir head pressure.

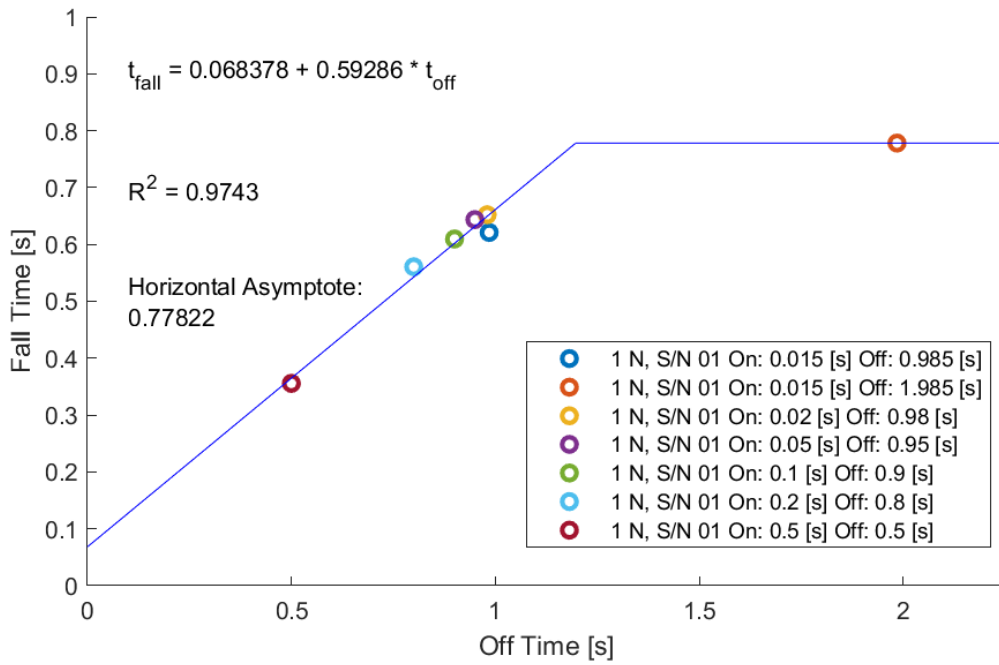

Figure 6. Thruster valve average fall time as measured by the differential pressure transducer against the off time for 1 N thruster valves at 150 psig reservoir head pressure.

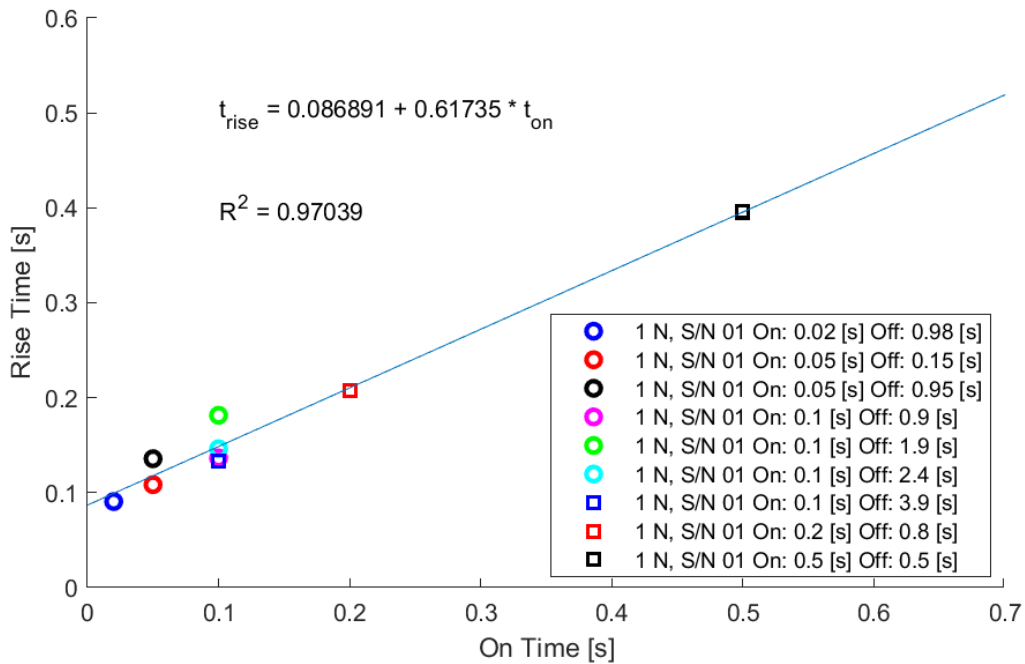
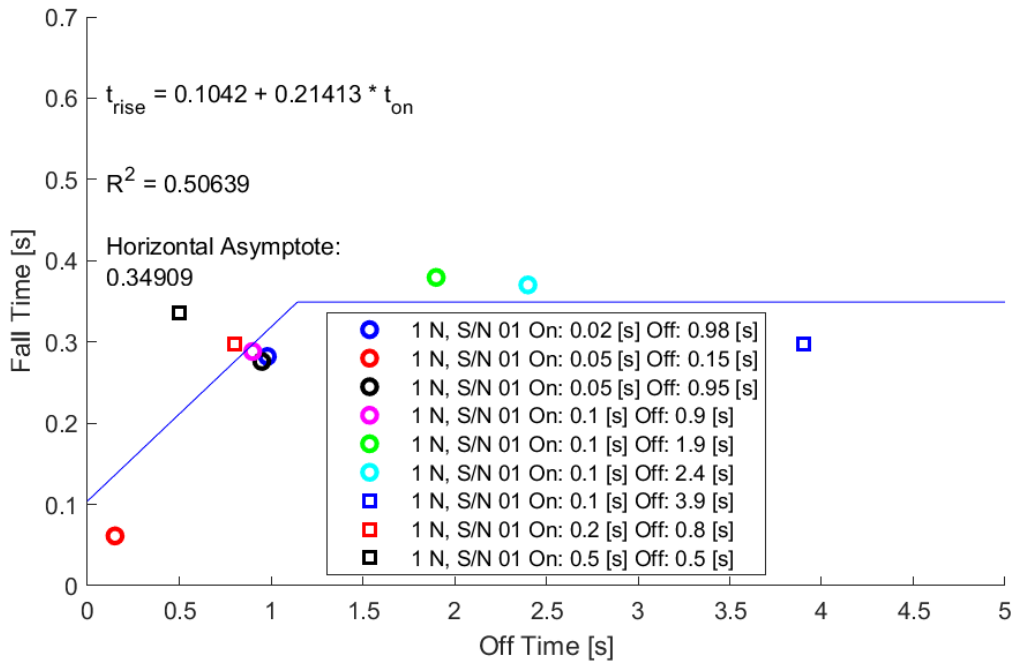

Figure 7. Thruster valve average rise time as measured by the differential pressure transducer against the commanded on time for 1 N thruster valves at 280 psig reservoir head pressure.



**Figure 8. Thruster valve average fall time as measured by the differential pressure transducer against the off time for 1 N thruster valves at 280 psig reservoir head pressure.**

In **Figure 3** through **Figure 8**, linear best fit lines were added for clarity to the average rise time and fall time figures. The figures that present the average fall times against the off time indicate an approximate ceiling is reached after off time of greater than approximately 1 to 2 s. These linear approximations are presented in **Figure 9** and **Figure 10** for all reservoir head pressures in phase 1. It can be seen in **Figure 9** that the average rise time for thruster valves are very similar for the 80 psig and 150 psig reservoir head pressure. The 280 psig average rise times are faster, but not remarkably so. **Figure 10** presents a more interesting perspective in that the fall time ceilings are clearly differentiated by the reservoir head pressure while the linear portion of the chart remains consistent with the average rise time figure.

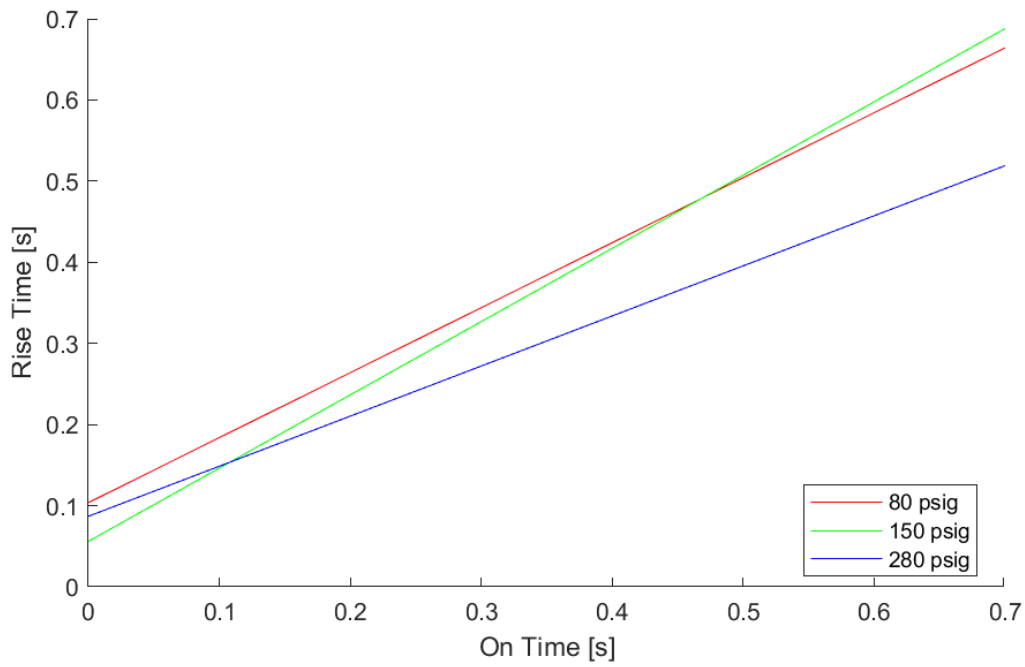

Figure 9. Linear best fit lines for the average rise time taken from Figure 3, Figure 5, and Figure 7 against the commanded on time for tested reservoir head pressures in phase 1.

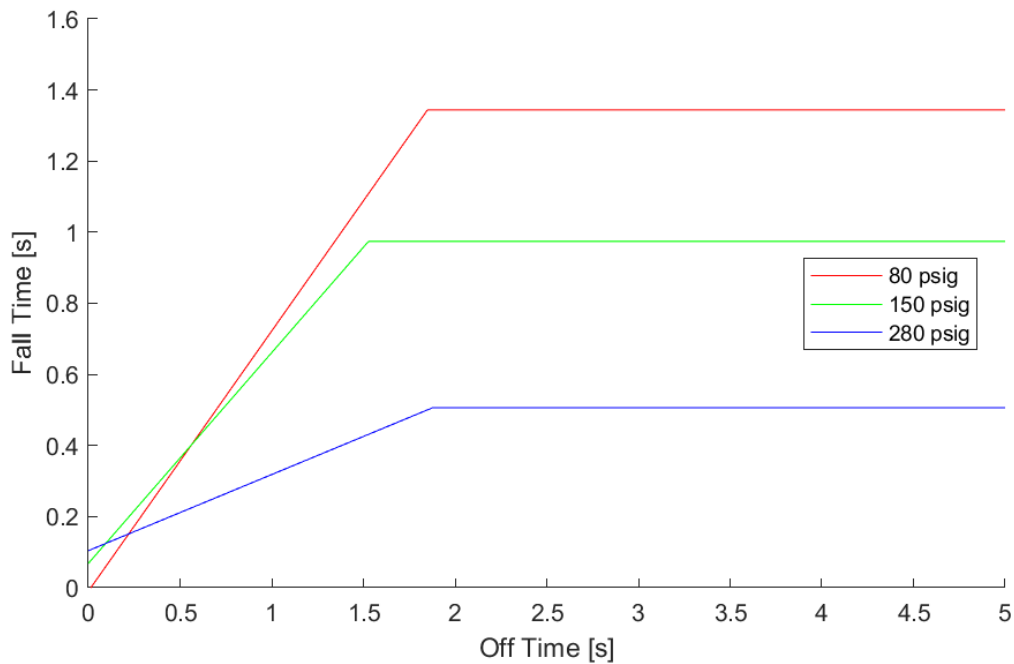
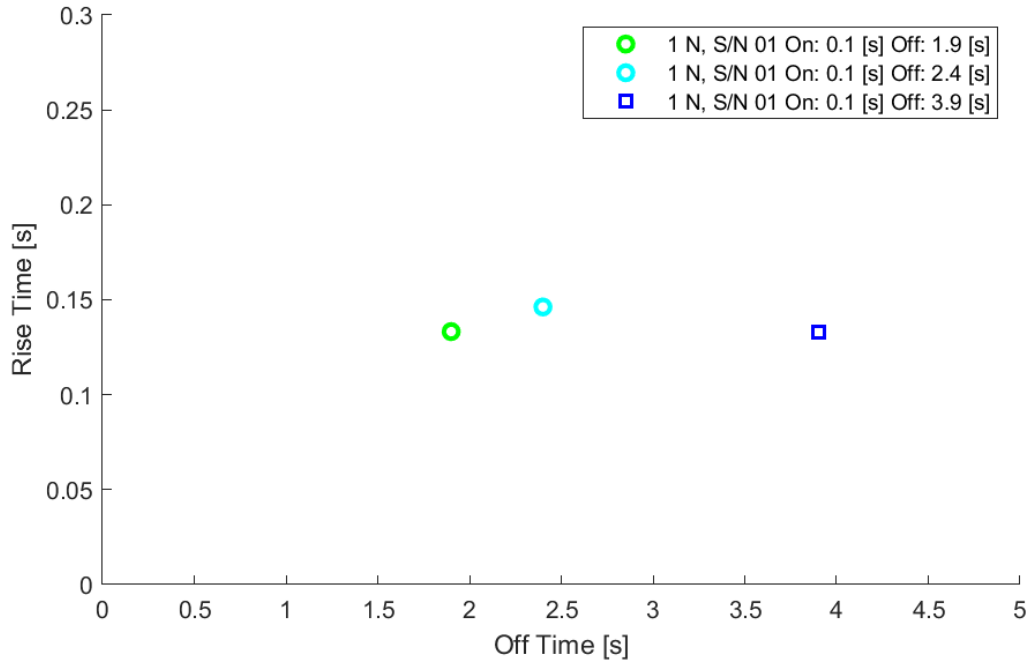
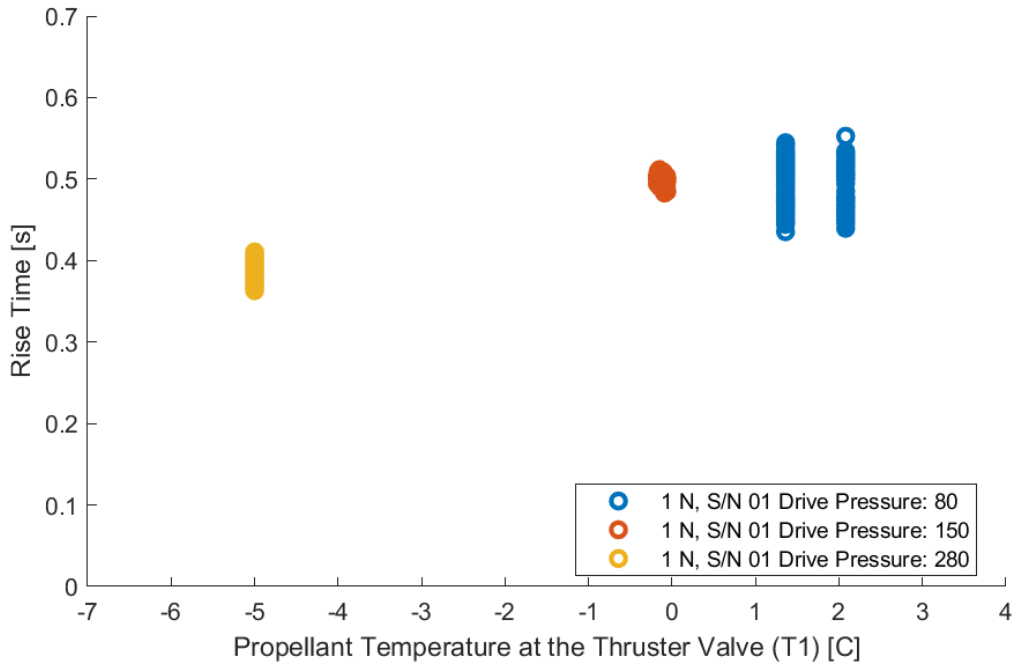

Figure 10. Linear best fit lines for the average fall time taken from Figure 4, Figure 6, and Figure 8 against the off time for tested reservoir head pressures in phase 1.

Additionally, in **Figure 11**, the average differential pressure measured rise time is plotted against the off time for data sets that had a commanded on time of 0.1 s. The rise times were averaged for each on and off time pairs. This figure shows that the rise time remains nearly constant independently of the off time. **Figure 12** and **Figure 13** detail the differential pressure measured rise and fall times for the commanded on time and off time of 0.5 s against the propellant temperature measured at the thruster valve. The charts show a near constant relation regardless of change in propellant temperature or the reservoir head pressure.



**Figure 11. Thruster valve average rise time as measured by the differential pressure transducer against the off time where temperature T2 was measured for 1 N thruster valves at 280 psig head pressure.**



**Figure 12. Thruster valve rise time as measured by the differential pressure transducer against the propellant temperature (T1) for all reservoir pressures for on times of 0.5 s and off times of 0.5 s.**

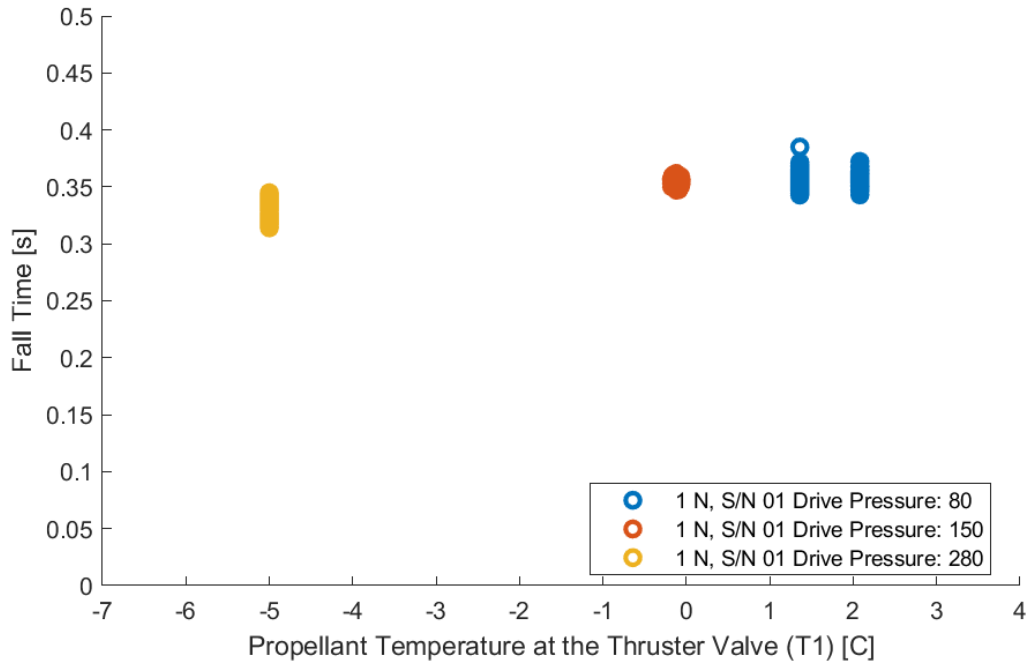

**Figure 13. Thruster valve fall time as measured by the differential pressure transducer against the propellant temperature (T1) for all reservoir pressures for on times of 0.5 s and off times of 0.5 s.**

#### D. Phase 2 Testing

The second phase of testing was conducted on the provided 1 N valve (P/N 40988-501, S/N 0001). The general results for testing in phase 2 can be found in **Appendix D, Figure 51** through **Figure 64**. Phase 2 looked into comparing rise and fall times with constant commanded on and off times and a consistent reservoir head pressure of 260 psig. This data also included temperature measurements of the thruster valve body while adding and removing heat to the thruster valve. These temperature changes were created by the use of a LN2 sprayer to cool the thruster valve body. To increase the temperature, the thruster valve was left in an open state allowing the solenoid to raise the valve body temperature.

Two distinct target propellant reservoir temperatures were used for the testing conducted in phase 2. The first iteration was operated with the propellant reservoir temperature held at 0 C. The next iteration was operated while the propellant reservoir temperature was within the range of 14 C to 18 C. As can be seen in **Figure 14** and **Figure 15**, these two temperature conditions affect the rise and fall time of the thruster valve. Clear delineations can be seen indicating that there is a thruster valve body temperature dependence for the rise and fall times as well as propellant temperature dependence. In general, as the temperature declines, the rise and fall times for the differential pressure measured values increase, more so for the rise times than the fall times, but both are affected. **Table 8** and **Table 9** presents the average calculated on time, average measured rise time and fall time for the testing conducted in phase 2.

**Table 8. P/N 40988-501 S/N 0001 with reservoir head pressure 260 psig average calculated on time and average measured rise and fall times for phase 1 testing for the differential pressure transducer measured data.**

On Time [s]	Off Time [s]	Calculated On Time [s]	Measured Rise Time [s]	Measured Fall Time [s]
0.5	4.5	0.612	0.359	0.301

**Table 9. P/N 40988-501 S/N 0001 with reservoir head pressure 260 psig average calculated on time and average measured rise and fall times for phase 1 testing for the measured current data.**

On Time [s]	Off Time [s]	Calculated On Time [s]	Measured Rise Time [s]	Measured Fall Time [s]
0.5	4.5	0.498	0.024	0.009

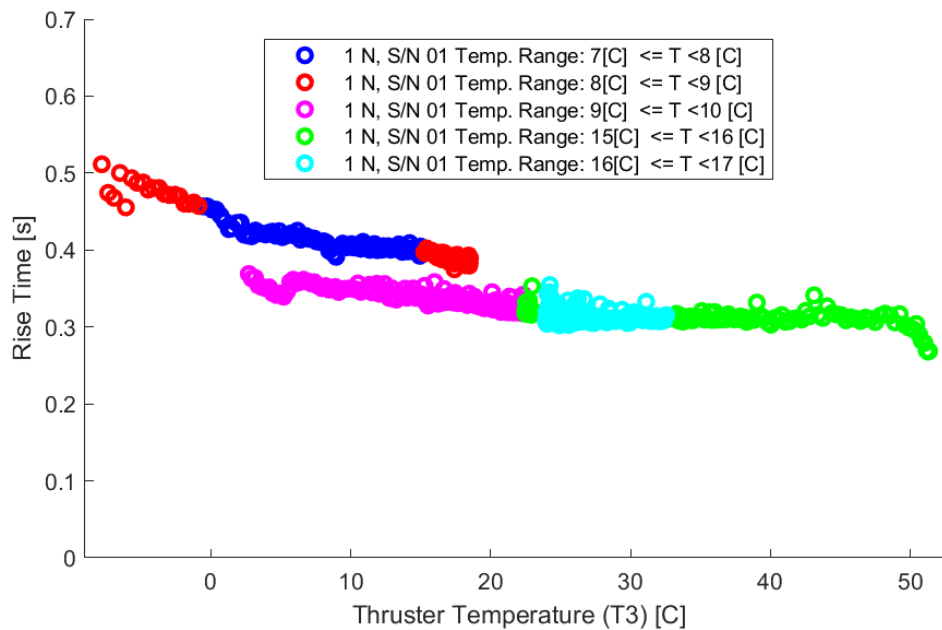

**Figure 14.** Thruster valve rise time as measured by the differential pressure transducer against the thruster valve body temperature measured at T3 for 1 N thruster valves at 260 psig reservoir head pressure. Gradients were added to show the variations due to the propellant temperature measured at T1.

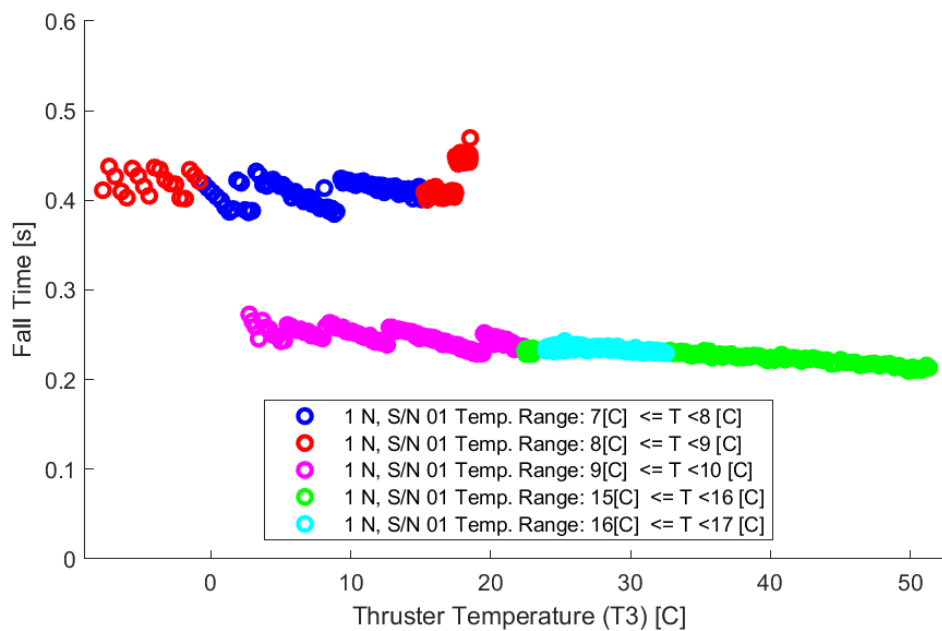

**Figure 15.** Thruster valve fall time as measured by the differential pressure transducer against the thruster valve body temperature measured at T3 for 1 N thruster valves at 260 psig reservoir head pressure. Gradients were added to show the variations due to the propellant temperature measured at T1.

### E. Phase 3 Testing

The third phase of testing was conducted on all 1 N and 22 N valves (P/N 40988-501 and P/N 40989-501). Testing for phase 3 was focused on variability between the provided thruster valves with constant commanded on and off times and varied temperatures for each 1 N and 22 N valves. The testing was conducted at three distinct head pressures: 125 psig, 260 psig, and 410 psig.

The general results for the 1 N and 22 N thruster valve testing of phase 3 are presented in **Appendix D**. These figures present the rise and fall time calculated from the differential pressure transducer traces against the propellant temperature measured at the valve (T1) and the reservoir propellant temperature (T2). These general results are listed accordance to pressure:

- 1 N thruster valves
  - 125 psig in **Figure 39** through **Figure 43**
  - 260 psig in **Figure 51** through **Figure 58**, **Figure 63**, and **Figure 64**
  - 410 psig in **Figure 81** through **Figure 89**
- 22 N thruster valves
  - All pressures in **Figure 90** through **Figure 115**

**Table 10** through

Table 13 presents the average calculated on time, average measured rise time and fall time for the testing conducted in phase 3 for all provided valves. **Table 10** and **Table 11** highlight the results from the testing conducted with the 1 N valve testing. The differential pressure transducer measured traces showed consistent calculated on times and descending measured rise times. The measured fall times present a variation that does not have a direct trend. The oscilloscope measured current traces were consistent through all tested pressures. These results are presented in **Figure 16** through **Figure 19**.

Table 12 and

Table 13 present the results from the 22 N valve testing.

Table 12 presents the averaged, calculated on times, measured rise and fall times for the 22 N valves. The calculated on times were all consistent between the valves while the rise and fall times for the S/N 0004 were considerably higher.

Table 13 details the oscilloscope measured current traces results. The calculated on time and fall time values were consistent through all of this phase of testing. The measured rise times were higher for S/N 0006. These results are

presented in **Figure 20** through **Figure 23**. **Figure 24** presents representative pulses for the testing conducted at the reservoir head pressure of 410 psig. It can be seen that S/N 0004 had longer measured rise and fall times compared to the other two. **Figure 25** details the individual traces for this set of data.

**Table 10. P/N 40988-501 S/N 0002 average calculated on time and average measured rise and fall times for phase 1 testing for the differential pressure transducer measured data.**

Pressure [psig]	On Time [s]	Off Time [s]	Calculated On Time [s]	Measured Rise Time [s]	Measured Fall Time [s]
125	0.5	24.5	0.520	0.183	0.253
260	0.5	24.5	0.520	0.177	0.270
410	0.5	24.5	0.526	0.161	0.228

**Table 11. P/N 40988-501 S/N 0002 average calculated on time and average measured rise and fall times for phase 1 testing for the measured current data.**

Pressure [psig]	On Time [s]	Off Time [s]	Calculated On Time [s]	Measured Rise Time [s]	Measured Fall Time [s]
125	0.5	24.5	0.498	0.022	0.007
260	0.5	24.5	0.498	0.022	0.007
410	0.5	24.5	0.498	0.022	0.007

**Table 12. P/N 40989-501, all valves, average calculated on time and average measured rise and fall times for phase 1 testing for the differential pressure transducer measured data.**

Pressure [psig]	Valve S/N	On Time [s]	Off Time [s]	Calculated On Time [s]	Measured Rise Time [s]	Measured Fall Time [s]
125	1	0.5	24.5	0.501	0.087	0.175
125	4	0.5	24.5	0.500	0.229	0.467
125	6	0.5	24.5	0.506	0.082	0.161
260	1	0.5	24.5	0.500	0.068	0.135
260	4	0.5	24.5	0.520	0.184	0.335
260	6	0.5	24.5	0.502	0.078	0.168
410	1	0.5	24.5	0.500	0.071	0.146
410	4	0.5	24.5	0.520	0.195	0.300
410	6	0.5	24.5	0.502	0.084	0.153

**Table 13. P/N 40989-501, all valves, average calculated on time and average measured rise and fall times for phase 1 testing for the measured current data.**

Pressure [psig]	Valve S/N	On Time [s]	Off Time [s]	Calculated On Time [s]	Measured Rise Time [s]	Measured Fall Time [s]
125	1	0.5	24.5	0.498	0.016	0.007
125	4	0.5	24.5	0.498	0.017	0.007
125	6	0.5	24.5	0.498	0.021	0.007
260	1	0.5	24.5	0.498	0.016	0.007
260	4	0.5	24.5	0.498	0.015	0.007
260	6	0.5	24.5	0.498	0.021	0.007
410	1	0.5	24.5	0.498	0.015	0.007
410	4	0.5	24.5	0.498	0.015	0.007
410	6	0.5	24.5	0.498	0.022	0.007

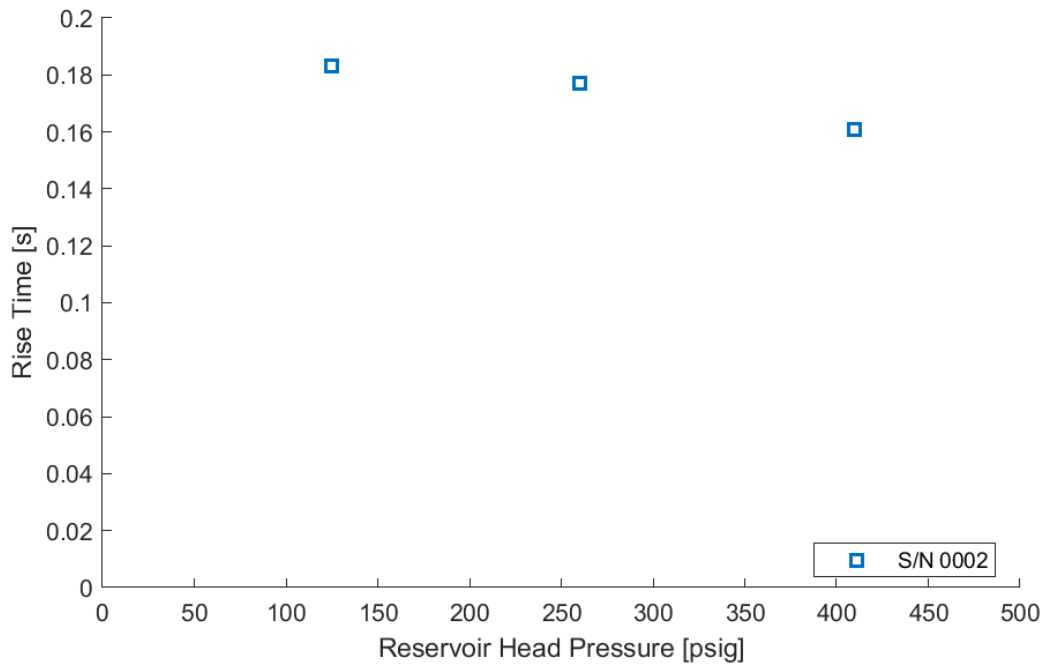

**Figure 16. P/N 40988-501 S/N 0002 plotted average differential pressure measured rise times against the reservoir head pressure.**

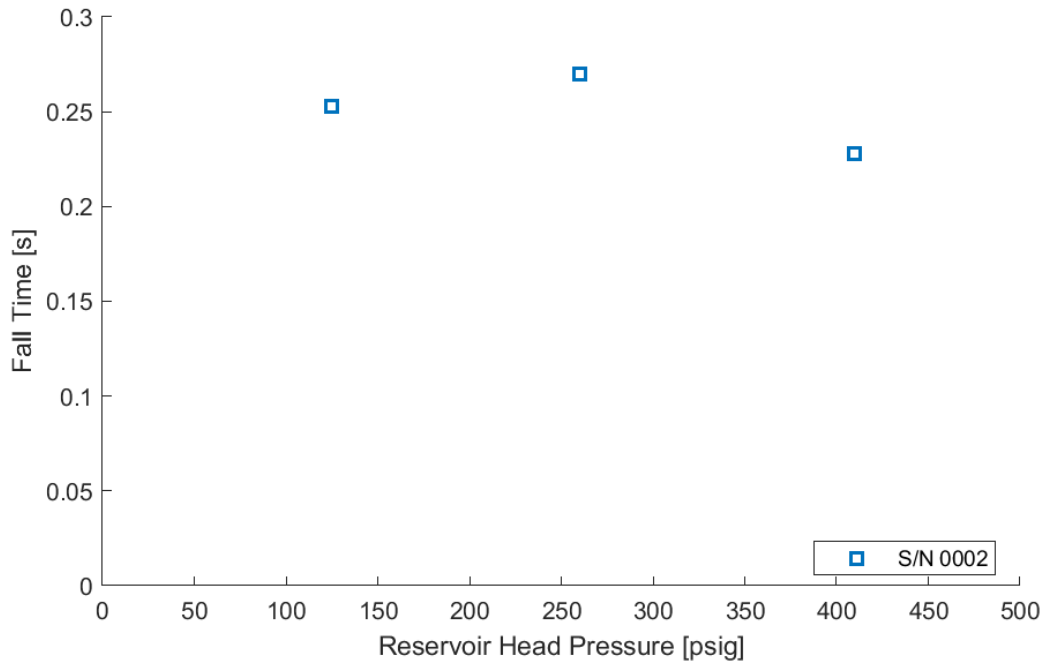

**Figure 17. P/N 40988-501 S/N 0002 plotted average differential pressure measured fall times against the reservoir head pressure.**

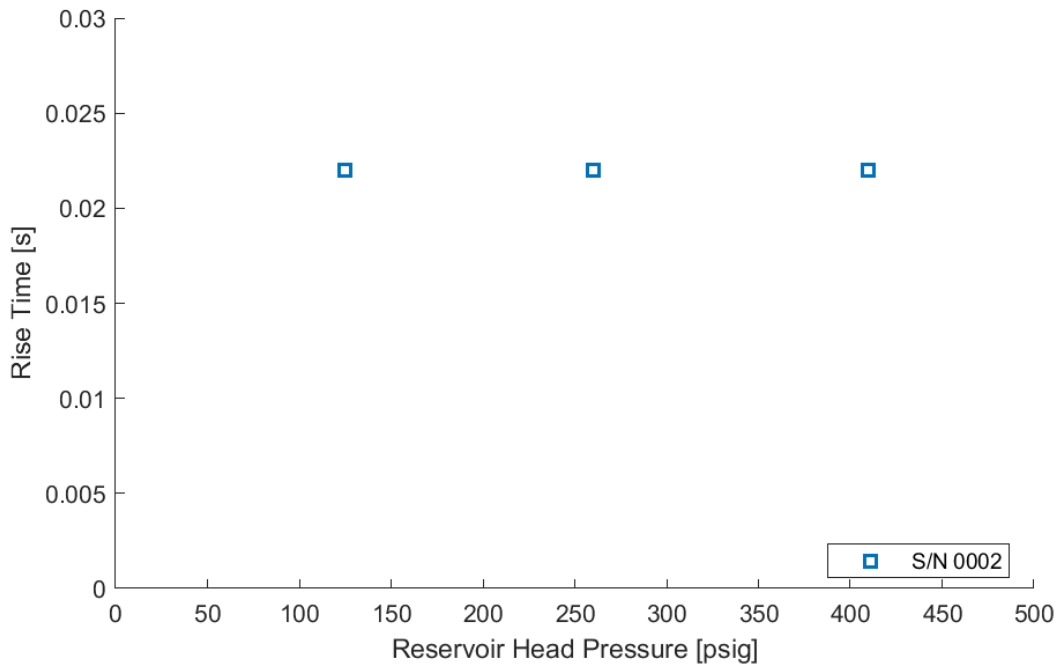

**Figure 18. P/N 40988-501 S/N 0002 plotted average current measured rise times against the reservoir head pressure.**

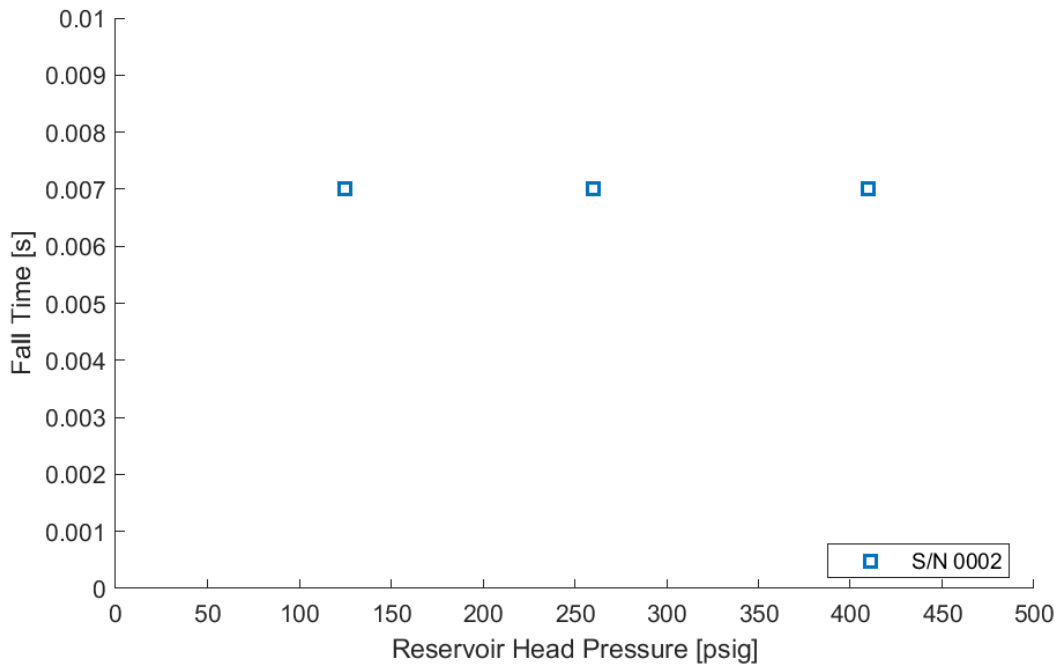

Figure 19. P/N 40988-501 S/N 0002 plotted average current measured fall times against the reservoir head pressure.

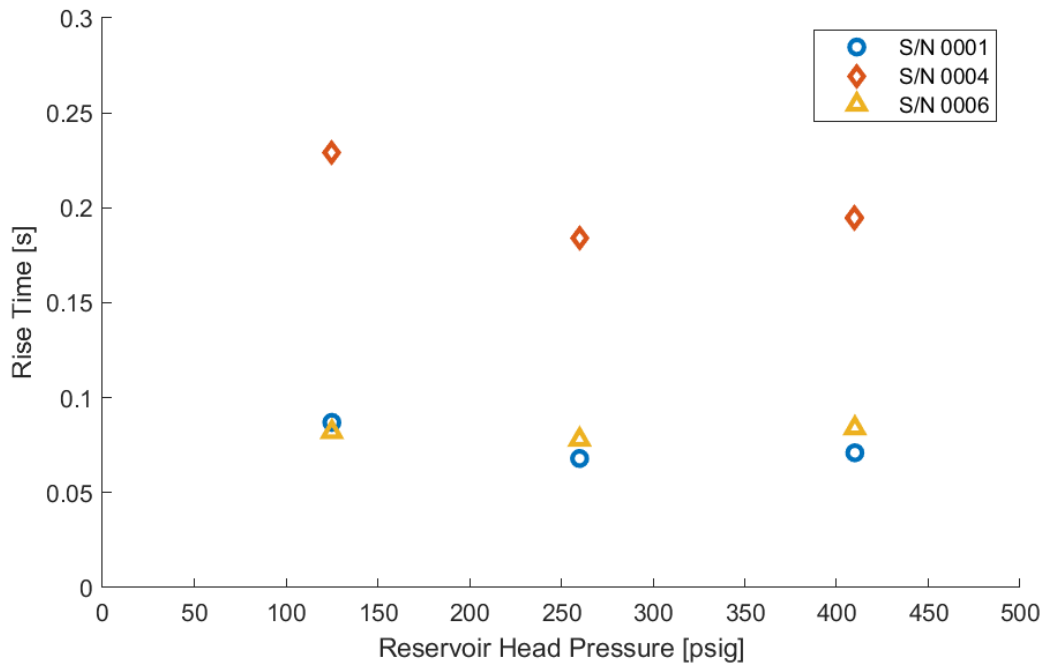
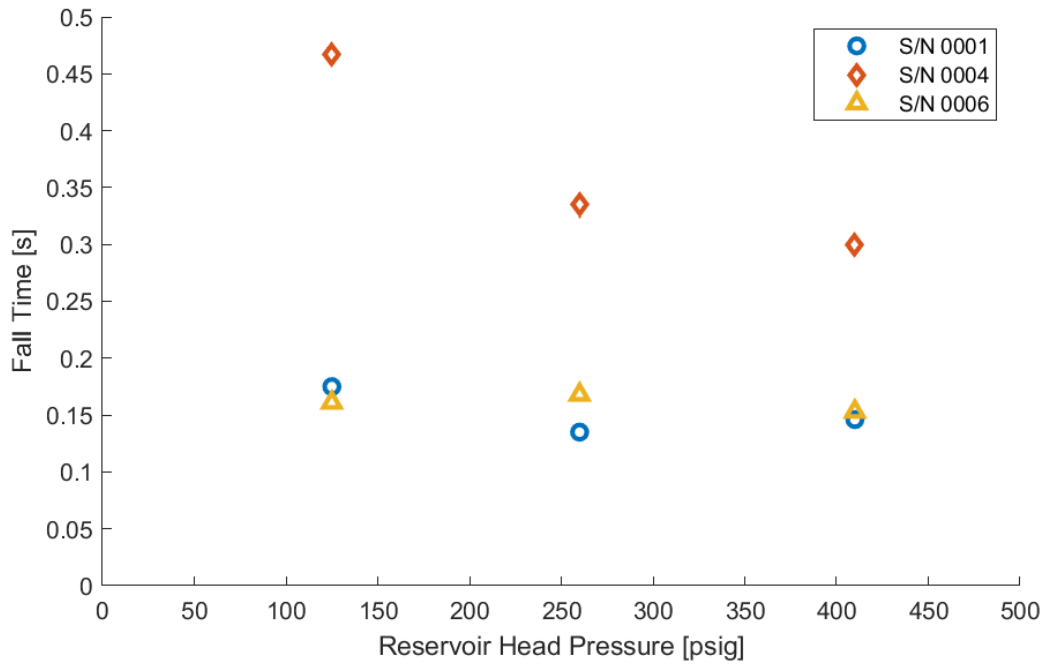
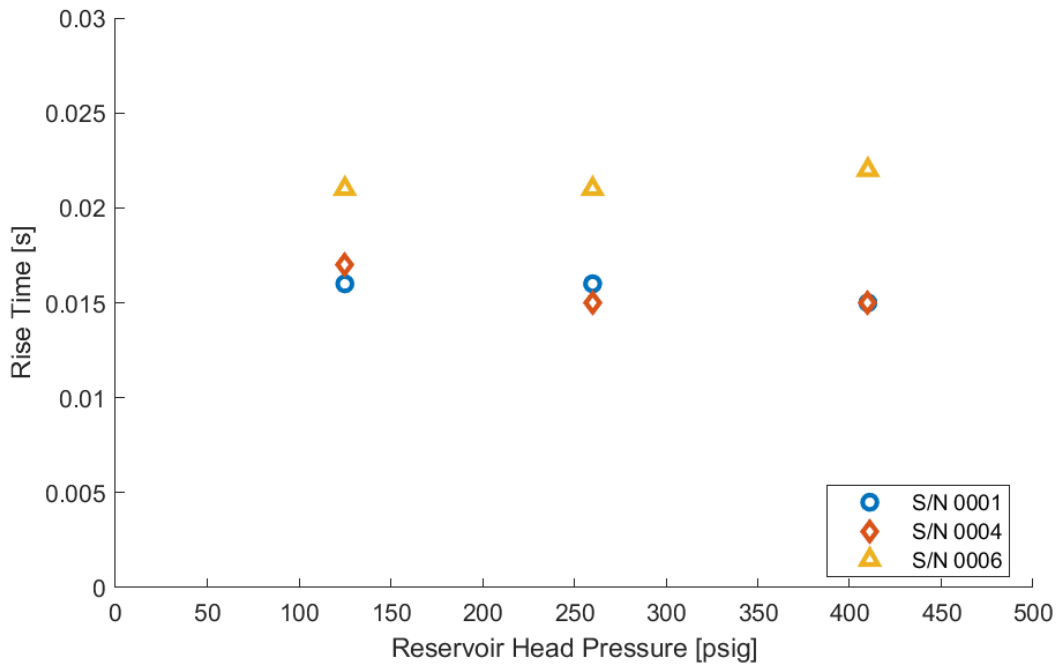

Figure 20. All P/N 40989-501 plotted average differential pressure measured rise times against the reservoir head pressure.



**Figure 21. All P/N 40989-501 S/N plotted average differential pressure measured fall times against the reservoir head pressure.**



**Figure 22. All P/N 40988-501 plotted average current measured rise times against the reservoir head pressure.**

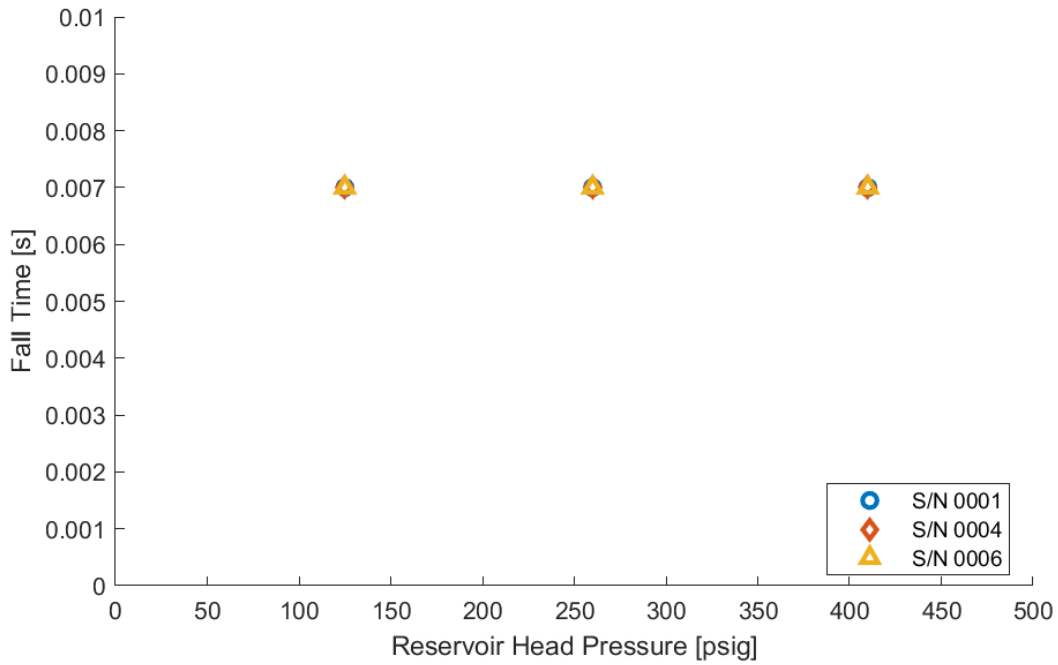

Figure 23. All P/N 40988-501 plotted average current measured fall times against the reservoir head pressure.

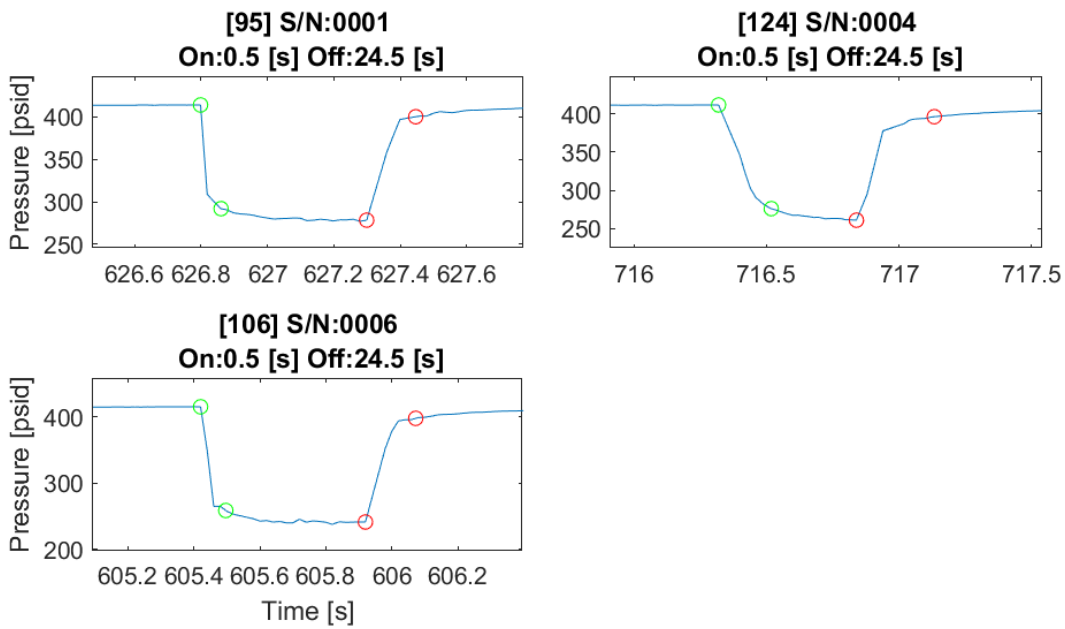
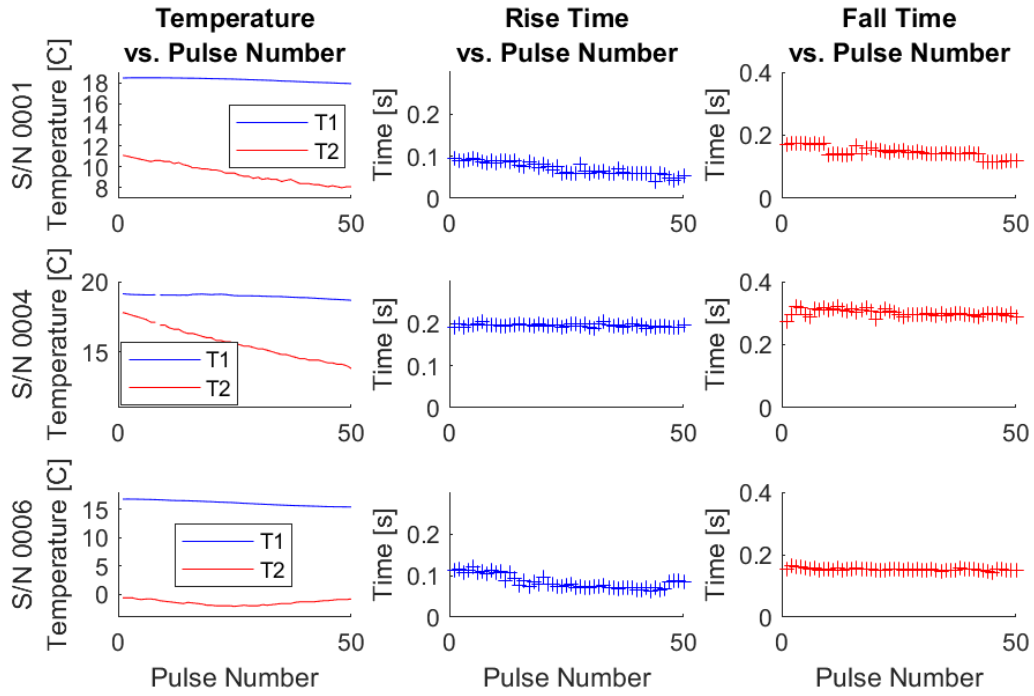

Figure 24. Thruster valve traces of the differential pressure transducer for each data set measured 22 N thruster valves at 410 psig reservoir head pressure.



**Figure 25. P/N 40989-501 temperature and measured rise and fall time values during the 410 psig reservoir head pressure testing.**

## F. Combined Results

**Figure 26** presents the consolidated results of the averaged calculated on times for all phases of testing plotted against the commanded on time. To highlight the expected behavior of the differential pressure trace calculated on time to the commanded on time, the ideal commanded on time line has been added for clarity. The difference of the averaged calculated on time from this line represents the lag of the differential pressure trace. The calculated on time data is represented by a best fit quadratic equation

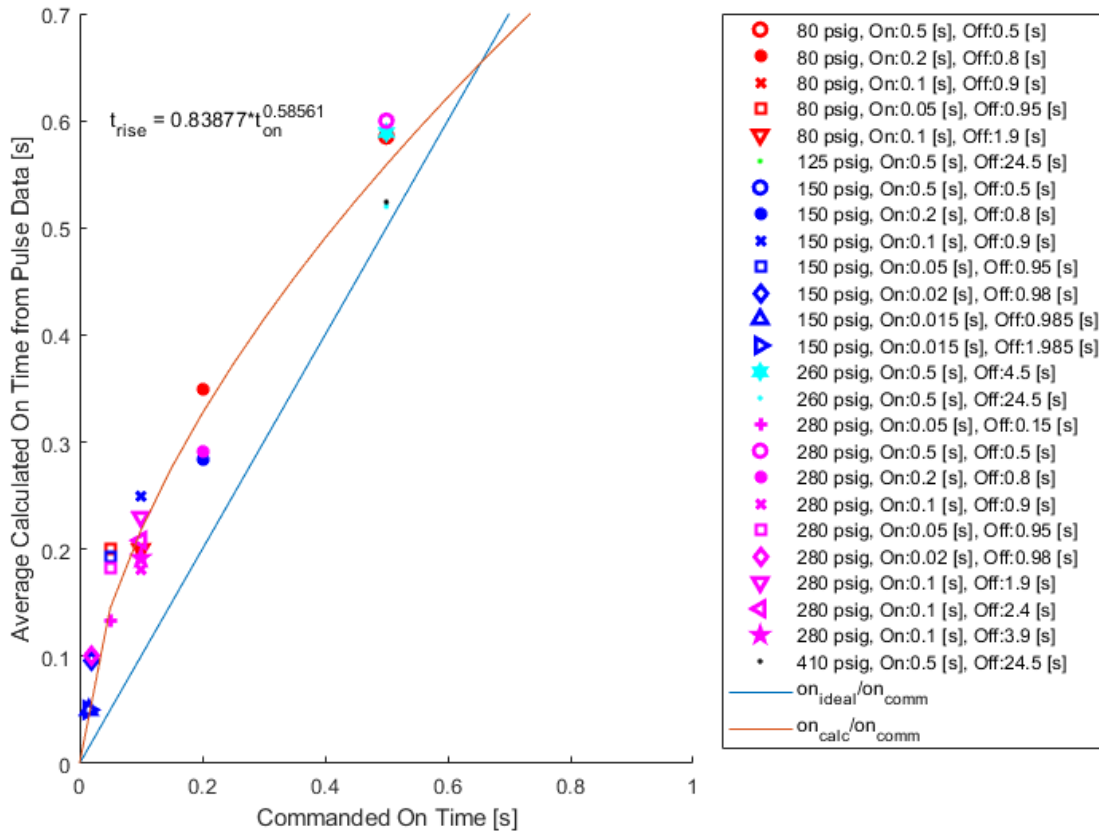

**Figure 26. Thruster valve calculated average on time measured by the differential pressure transducer versus the commanded on time for all propellant reservoir head pressures and all commanded on times for the 1 N thruster valves.**

#### **IV. Conclusion**

The testing conducted at GSFC enables the understanding of how the provided thruster valves respond to the characteristics of AF-M315E in flight-like conditions. Given the substantial density and viscosity changes with temperature, obtaining test data at the low and upper temperature ranges would allow flight projects using AF-M315E to more accurately model system performance and design propulsion systems and components.

The data presented highlights several key conclusions. First, that the rise and fall times calculated from the oscilloscope measured current traces is extremely consistent, regardless of reservoir head pressure, commanded on and off time, and temperature of the propellant or the individual valves. The comparison of the different valve sizes (1 N and 22 N) show that the 22 N valves, in general, have a shorter measured rise time with a consistent measured fall time. The valve to valve variation among the valves tested showed minor variations between the 1 N valves, while a 22 N valve (S/N 0006) presented current trace rise times consistent with the 1 N valves instead of the shorter rise time for the other 22 N valves. The small variations seen in the oscilloscope measured currents do not seem to impact the differential pressure traces which are governed more by the propellant properties.

Another conclusion from the testing is that the differential pressure calculated on time is longer than the commanded on time. This is in conflict with the current trace calculated on time which has no lag compared to the commanded on time. This difference between the differential pressure trace and current trace is indicative of a lag between the differential pressure data.

The differential pressure calculated on time, rise time, and fall time show a heavy dependence on the propellant temperature. There also is a clear dependence on the thruster valve body temperature that affects these measurement parameters. As the temperature of the system decreases, the calculated on, rise, and fall times increase. This dependence clearly impacts the performance of the thruster valve.

The differential pressure calculated rise times also showed little variation due to reservoir head pressure. The largest variation due to reservoir head pressure was the affected fall time analysis of the differential pressure traces. This characteristic appears as a ceiling for the calculated fall times that decreases with pressure. This is a result of the fluid dynamics that occur at the shorter duty cycles with the valve not allowing the flow to reach steady-state equilibrium.

#### **V. Further Testing and Lessons Learned**

Throughout testing, various anomalies were detected and resulted in the inability to use the associated data in the analysis of the thruster valve testing. For example, there were sets of data taken where the differential pressure gage was not hydraulically hard with what was assumed to be an air bubble sitting on one side of the differential pressure transducer. This is an example given as an overview of challenges overcome in testing. Further analysis will follow.

For future testing, the thruster valves must be characterized with the propellant operating at flight like conditions. Thruster valve and other hardware change outs should be kept to a minimum to limit the variabilities that are introduced into the system. Additional testing must be conducted to verify the average rise and fall time data, especially the approximate ceilings for the fall time analysis. The current, voltage, and pressure measurements should be integrated into a single DAQ system, along with tracking of the actuation commands for the thruster valve being tested. Again, this is directed at attempting to limit the variabilities of testing.

## Appendix

### A. Flow Regimes for Thruster Valves

**Table 14. Phase 1 testing conditions and data set index for differential pressure measured traces.**

Valve P/N	Reservoir Head Pressure [psig]	Valve S/N	On Time [s]	Off Time [s]	T1 Range [C]	T2 Range [C]	Steady State Index
40988-501	80	1	0.05	0.95	0.6 to 1.1	-15.5 to -15.3	37
			0.05	1.95	N/A	N/A	
			0.1	0.9	1.3 to 1.7	-15.4 to -15.3	34
			0.1	1.9	0.9 to 1	-15.1 to -14.9	33
			0.2	0.8	-0.7 to -0.2	-14.7 to -13.9	35, 59
			0.2	1.8	N/A	N/A	
			0.5	0.5	1.4 to 2.1	-15.6 to -15.5	36
40988-501	150	1	0.015	0.985	1.8 to 2.1	-15.7 to -15.6	29
			0.015	1.985	3.1 to 3.1	-15.8 to -15.8	27
			0.02	0.98	1.5 to 2.1	-15.5 to -15.4	30
			0.05	0.95	-1 to -0.2	-14.6 to -14.4	32
			0.05	1.95	N/A	N/A	
			0.1	0.9	-0.8 to -0.7	-14.9 to -14.9	28
			0.2	0.8	-1 to 12.8	-15.5 to -15.5	25, 26
			0.2	1.8	N/A	N/A	
40988-501	280	1	0.02	0.98	-5 to -5	N/A	19
			0.05	0.15	-5 to -5	N/A	23
			0.05	0.95	-5 to -5	N/A	21, 22, 60, 84
			0.05	2.45	N/A	N/A	
			0.1	0.9	-5 to 13.6	-18 to -17.9	1, 16, 17, 107
			0.1	1.9	-5 to 11.5	-17.9 to -17.3	24, 50, 79
			0.1	2.4	-1.8 to 7.7	-17.3 to -13.9	51, 52, 80
			0.1	3.233	6.5 to 7.7	-15 to -14.5	
			0.1	3.9	4.1 to 4.4	-17.3 to -17.3	78
			0.1	4.9	6.5 to 6.8	-14.5 to -14.4	
			0.2	0.8	-5 to -5	N/A	18, 65, 66, 67, 83
			0.2	1.8	N/A	N/A	
			0.2	2.3	N/A	N/A	
			0.5	0.5	-5 to -5	N/A	20

**Table 15. Phase 2 testing conditions and data set index for differential pressure measured traces.**

Valve P/N	Reservoir Head Pressure [psig]	Valve S/N	On Time [s]	Off Time [s]	T1 Range [C]	T2 Range [C]	T3 Range [C]	Steady State Index
40988-501	260	1	0.5	4.5	7.8 to 17.4	-0.7 to 17.5	-17.3 to 51.4	45, 46, 69, 75, 76, 87, 108, 109

**Table 16. Phase 2 testing conditions and data set index for oscilloscope measured current traces.**

Valve P/N	Reservoir Head Pressure [psig]	Valve S/N	On Time [s]	Off Time [s]	Steady State Index
40988-501	260	1	0.5	4.5	45, 46, 69, 75, 76, 87, 109

**Table 17. Phase 3 testing conditions and data set index for differential pressure measured traces and oscilloscope measured current traces.**

Valve P/N	Reservoir Head Pressure [psig]	Valve S/N	On Time [s]	Off Time [s]	T1 Range [C]	T2 Range [C]	Steady State
40988-501	125	1	0.5	24.5	19.4 to 19.7	N/A	
		2	0.5	24.5	18.9 to 19.2	-0.2 to 0.8	117
	260	1	0.5	24.5	19 to 19.6	11.3 to 17.5	
		2	0.5	24.5	18.4 to 19.1	-0.7 to 1.1	101, 118, 119
	410	1	0.5	24.5	19.2 to 19.5	11.1 to 15.9	
		2	0.5	24.5	18.2 to 18.8	0.8 to 11.8	102, 103
40989-501	125	1	0.5	24.5	19.8 to 21	10.2 to 15	115
		2	0.5	24.5	19.1 to 19.7	10.7 to 15.4	
		4	0.5	24.5	21 to 24.3	12.4 to 15.8	116
		6	0.5	24.5	18.8 to 20	-2.5 to -1	104
	260	1	0.5	24.5	18.5 to 19.5	12.2 to 15.7	94
		2	0.5	24.5	18.2 to 19.1	9.9 to 15.3	
		4	0.5	24.5	18.9 to 20.7	16.3 to 17.4	98
		6	0.5	24.5	16.8 to 18.7	-2.5 to -0.8	105, 120
	410	1	0.5	24.5	17.9 to 18.5	8 to 11.2	95
		2	0.5	24.5	19.2 to 19.5	16.8 to 22.8	
		4	0.5	24.5	18.7 to 19.2	13.7 to 17.9	124
		6	0.5	24.5	15.4 to 16.8	-2.1 to -0.6	106

## B. Anomaly Analysis

Anomalies were detected during the analysis of the global data set for all phases of testing. The following figures represent the data sets that were considered anomalous. Of first consideration are data sets that were not hydraulically hard. **Figure 27** was indicative of the traces for these types of data sets. The characteristics for classifying data as not hydraulically hard were the exaggerated shape of the pulse, the high level of noise during the steady state portion, and the substantial ramp of the differential pressure in between pulses. Another common anomaly noted was that, for several data sets, the DAQ was not sampling at a high of enough rate resulting in the differential pressure trace becoming distorted. **Figure 28** is indicative of the traces for these types of data sets. These DAQ sample rate anomalies are confined to phase 2 testing. An anomaly that was isolated to a single battery of testing in phase 3 for a 22 N thruster valve (P/N 40989-501 S/N 0002) was associated with a grounding issue in the testing setup. Voltage spikes were picked up by the differential pressure transducer when the thruster valve opened and closed. All results, in phase 3, were inspected and found to be not affected by this anomaly. **Figure 29** presents an example of this phenomenon. The last variation that was encountered was at the start of several batteries of tests. It is assumed that the propellant required several pulses to completely flood the thruster valves during testing. **Figure 30** provides an example of this variation. Capturing quality differential pressure data required maintaining wet conditions downstream of the thruster valve.

The identification of the anomaly associated with individual data set array is given in **Table 18** of **Appendix 0**. These indices detail which data set array for each phase of testing is effected by the presumed anomaly. The performance data from these data sets was recorded but is not presented in the results.

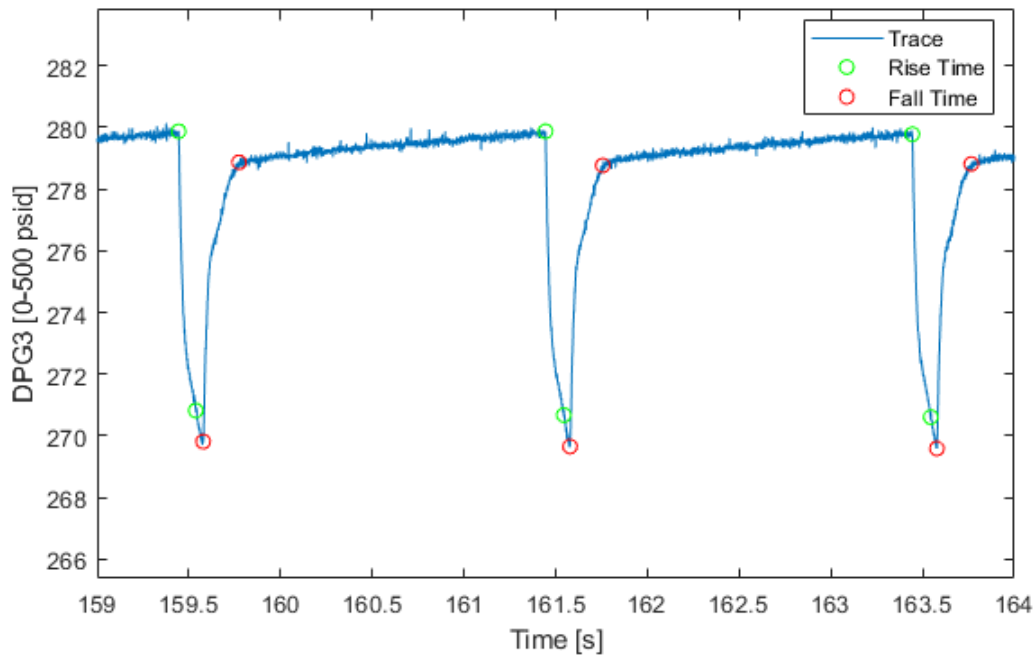

**Figure 27. Not hydraulically hard differential pressure transducer trace example.** Test data array: "LifeTest 280psi 051316 -NC 0.5Hz Crop2 Steady State.dat".

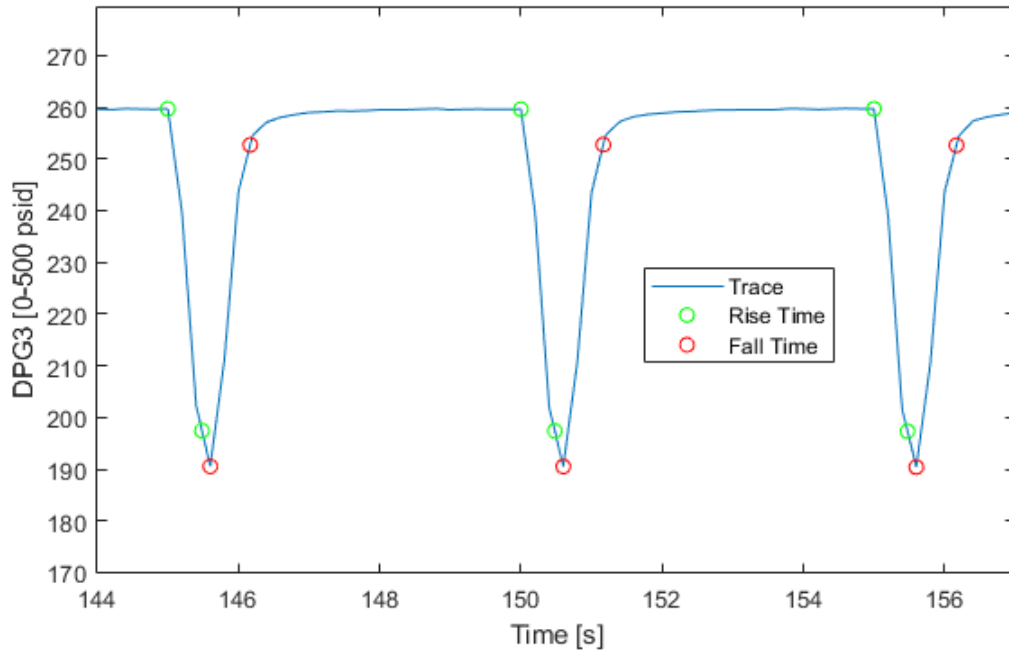

**Figure 28. Low sampling rate of differential pressure transducer trace example.** Test data array: "500ms 4500ms 031317 WarmedValve 5 Steady State.dat".

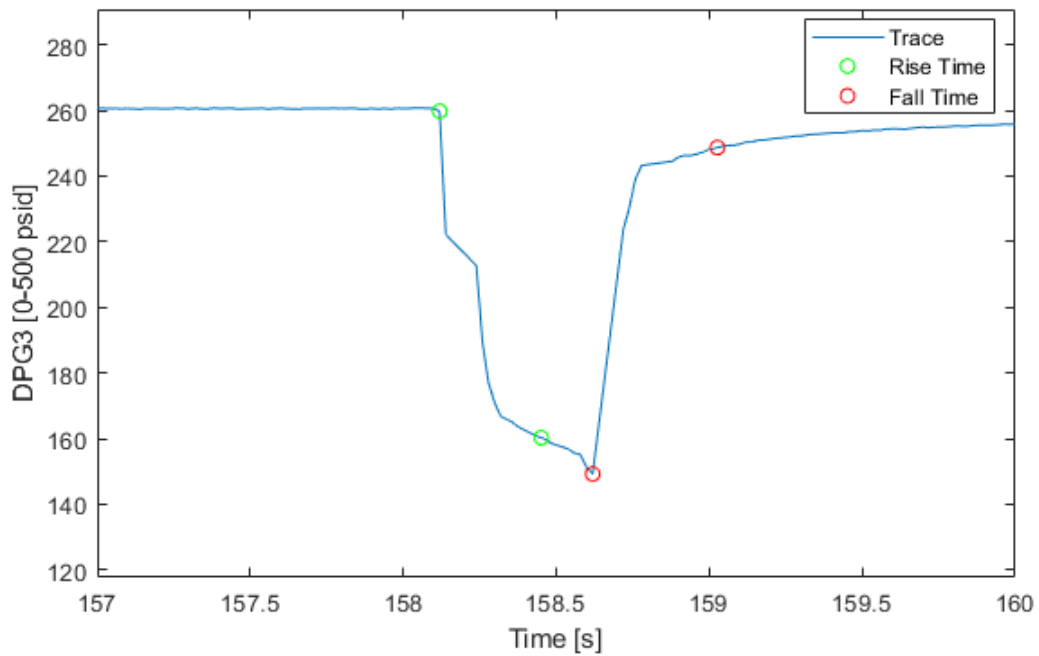

**Figure 29. Voltage spikes from the valve actuation measured by the differential pressure transducer trace example.** Test data array: "20171107 40989 501 S/N02 0.5 24.5 260 psig Run 1 steady state.dat". A smoothing function was used to minimize the impact of the voltage spikes.

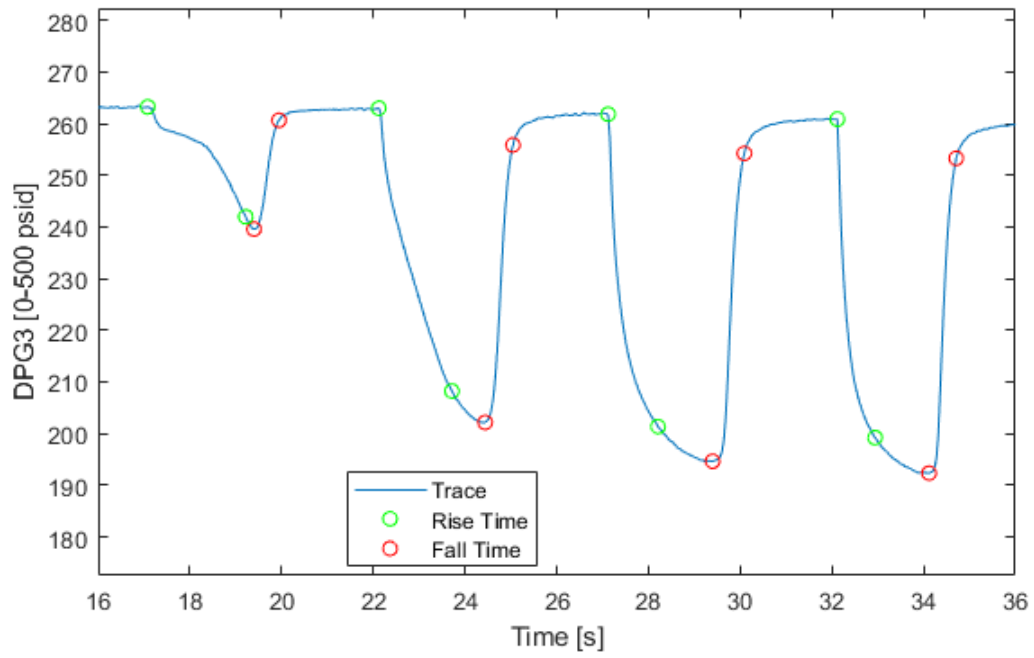

**Figure 30. Variation in the differential pressure transducer trace measured at the start of thruster valve testing example. Test data array: "500ms 4500ms 031317 ColdValve Transient.dat".**

**Table 18. Identification of the type of anomaly for the give data set index value.**

Differential Pressure Transducer Anomaly	Phase 1	Phase 2	Phase 3
Not Hydraulically Hard	2, 3, 10, 48, 49, 53, 54, 55, 56, 57, 61, 62, 77, 81, 82, 85, 86, 121, 122, 123		88, 89, 90, 91, 110, 111
Low DAQ Sample Rate		38, 40, 41, 42, 43, 44, 68, 70, 71, 72, 73, 74	
Valve Actuation Voltage Spikes			92, 99, 112, 113, 114
Initial Valve Flooding		39	93, 97, 100

### C. General Testing Apparatus Information

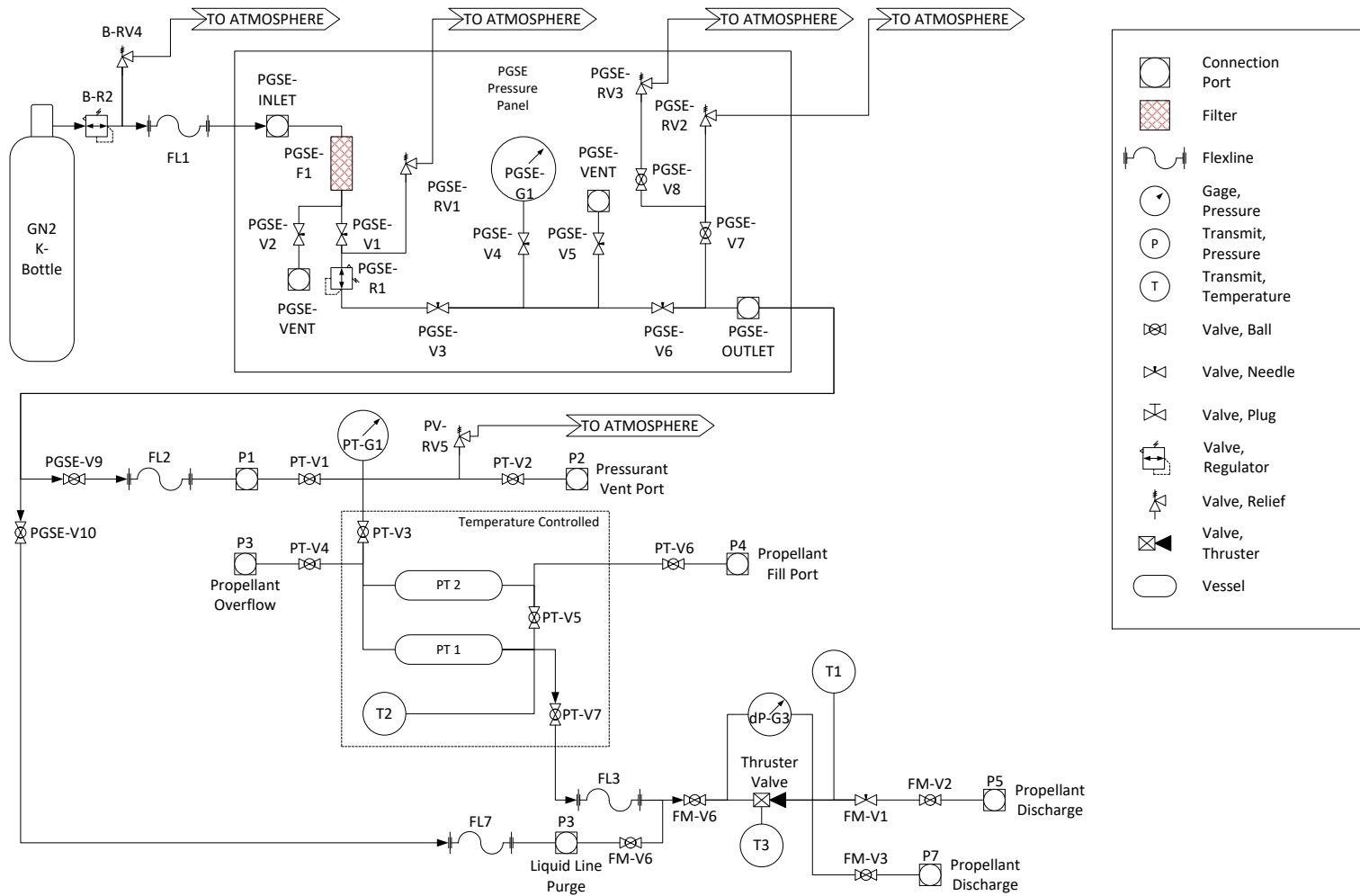

Figure 31. General layout of the thruster valve testing apparatus.

#### D. General Results of the Thruster Valves Rise and Fall Times Plots

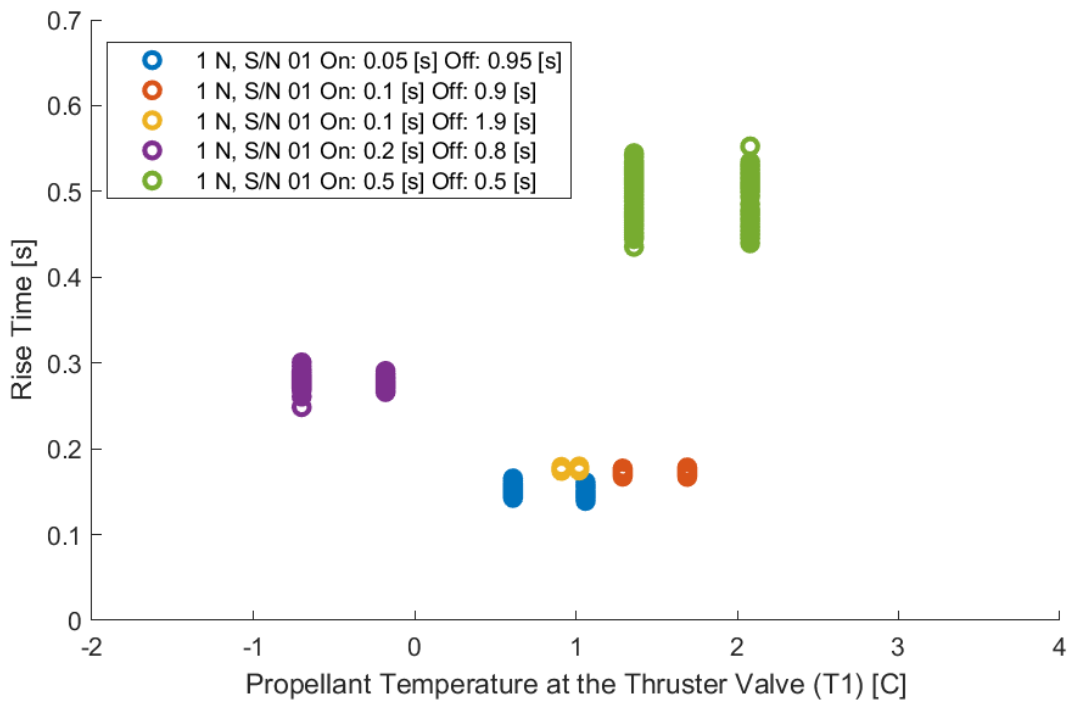
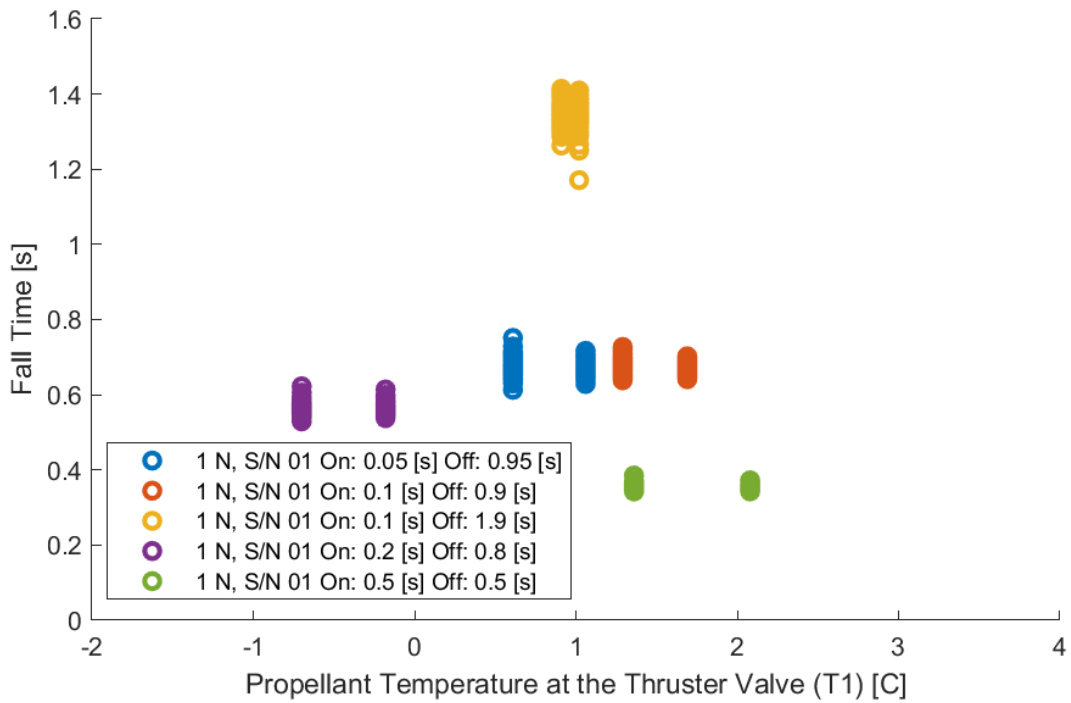
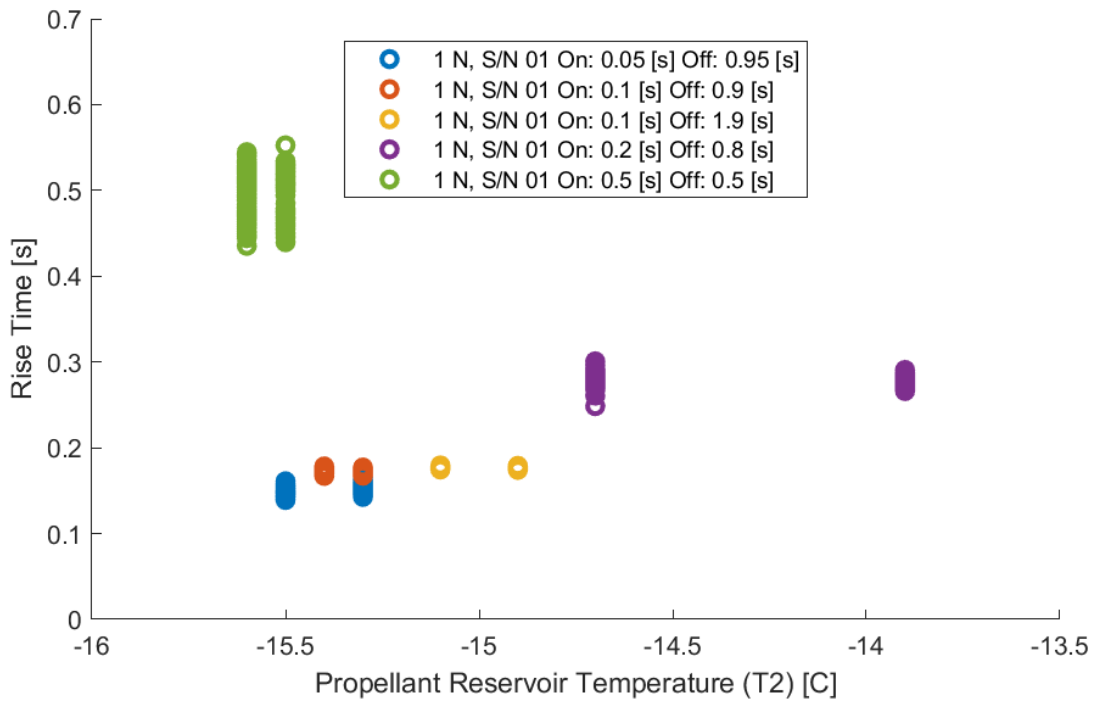

Figure 32. Thruster valve rise time as measured by the differential pressure transducer against the propellant temperature measured at T1 for 1 N thruster valves at 80 psig reservoir head pressure.



**Figure 33. Thruster valve fall time as measured by the differential pressure transducer against the propellant temperature measured at T1 for 1 N thruster valves at 80 psig reservoir head pressure.**



**Figure 34. Thruster valve rise time as measured by the differential pressure transducer against the propellant reservoir temperature measured at T2 for 1 N thruster valves at 80 psig reservoir head pressure.**

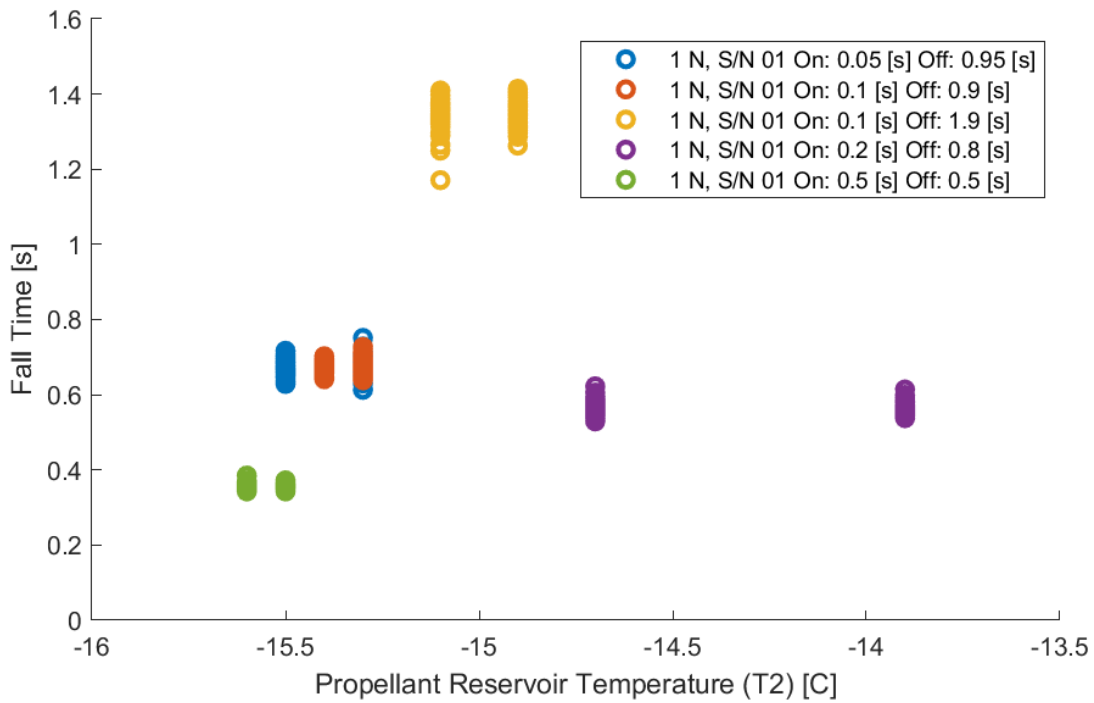

**Figure 35. Thruster valve fall time as measured by the differential pressure transducer against the propellant reservoir temperature measured at T2 for 1 N thruster valves at 80 psig reservoir head pressure.**

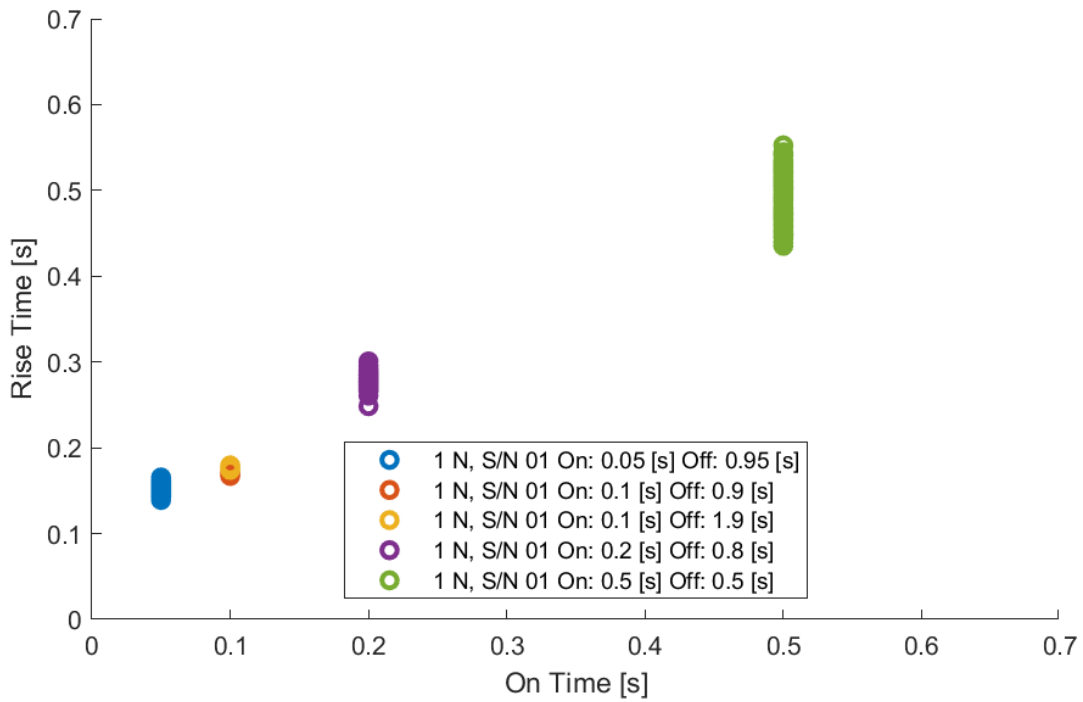

**Figure 36. Thruster valve rise time as measured by the differential pressure transducer against the commanded on time for 1 N thruster valves at 80 psig reservoir head pressure.**

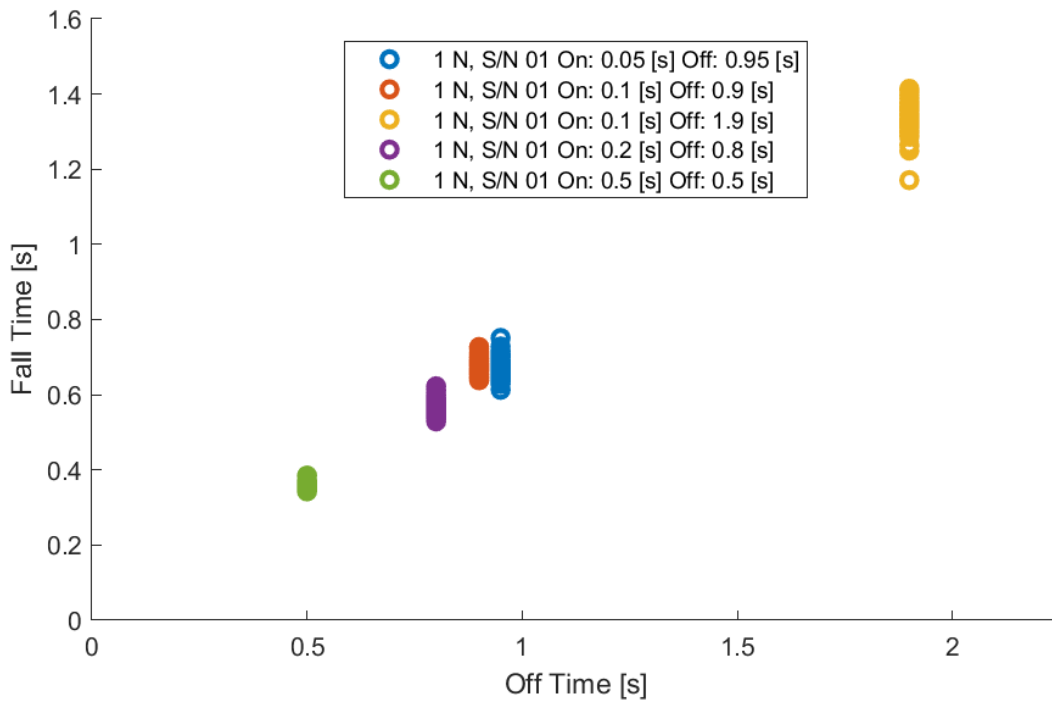

**Figure 37. Thruster valve fall time as measured by the differential pressure transducer against the off time for 1 N thruster valves at 80 psig reservoir head pressure.**

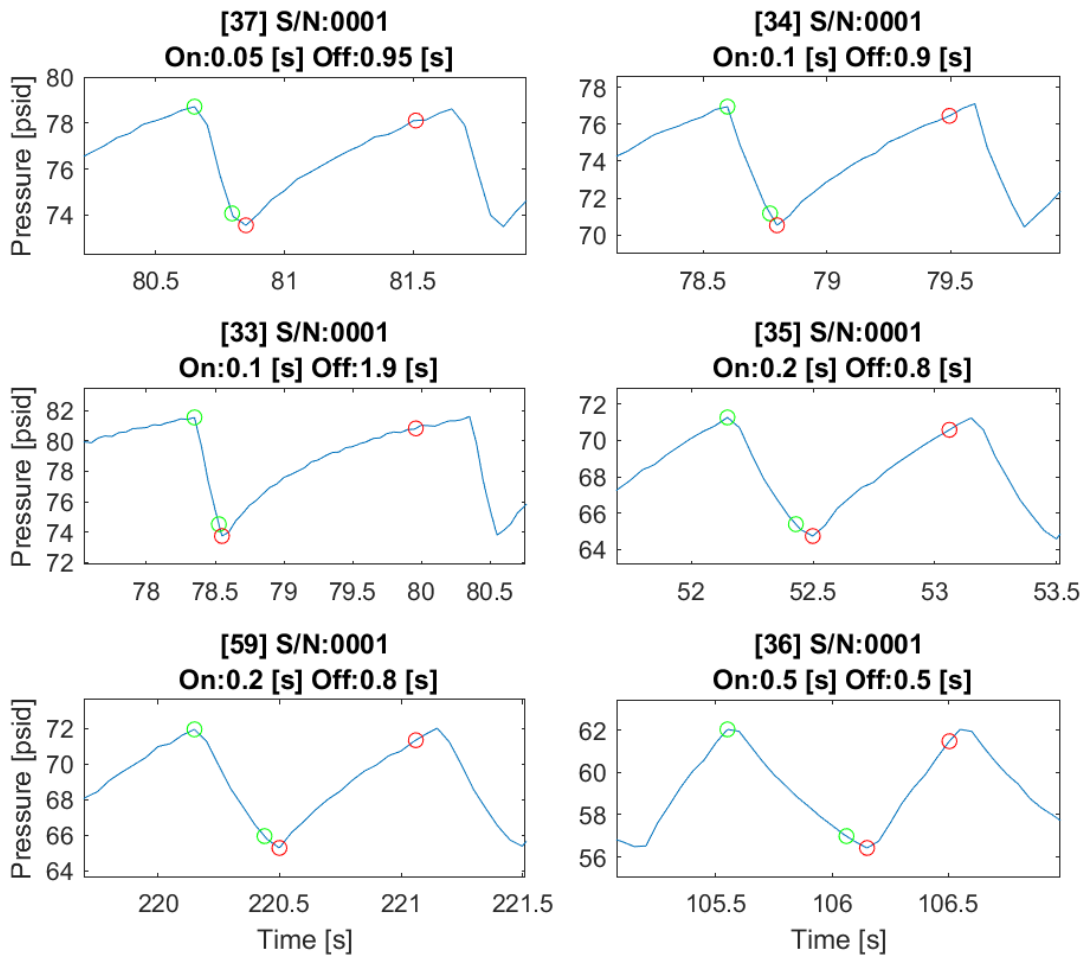

**Figure 38. Thruster valve traces of the differential pressure transducer for each data set measured 1 N thruster valves at 80 psig reservoir head pressure.**

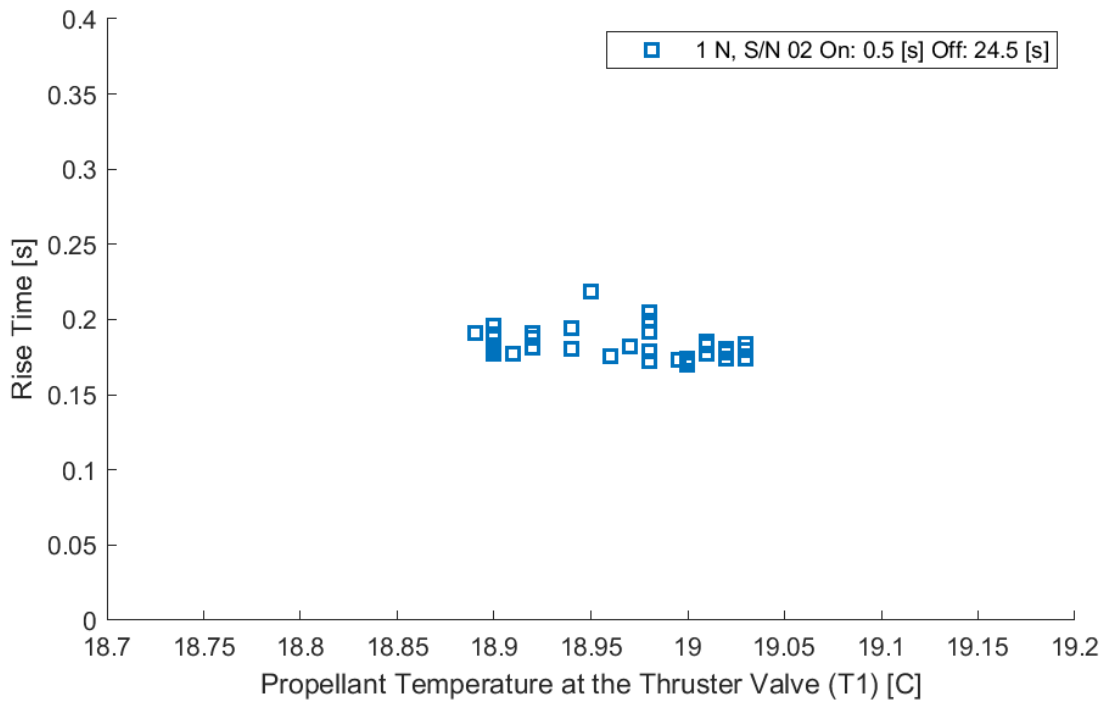

**Figure 39. Thruster valve rise time as measured by the differential pressure transducer against the propellant temperature measured at T1 for 1 N thruster valves at 125 psig reservoir head pressure.**

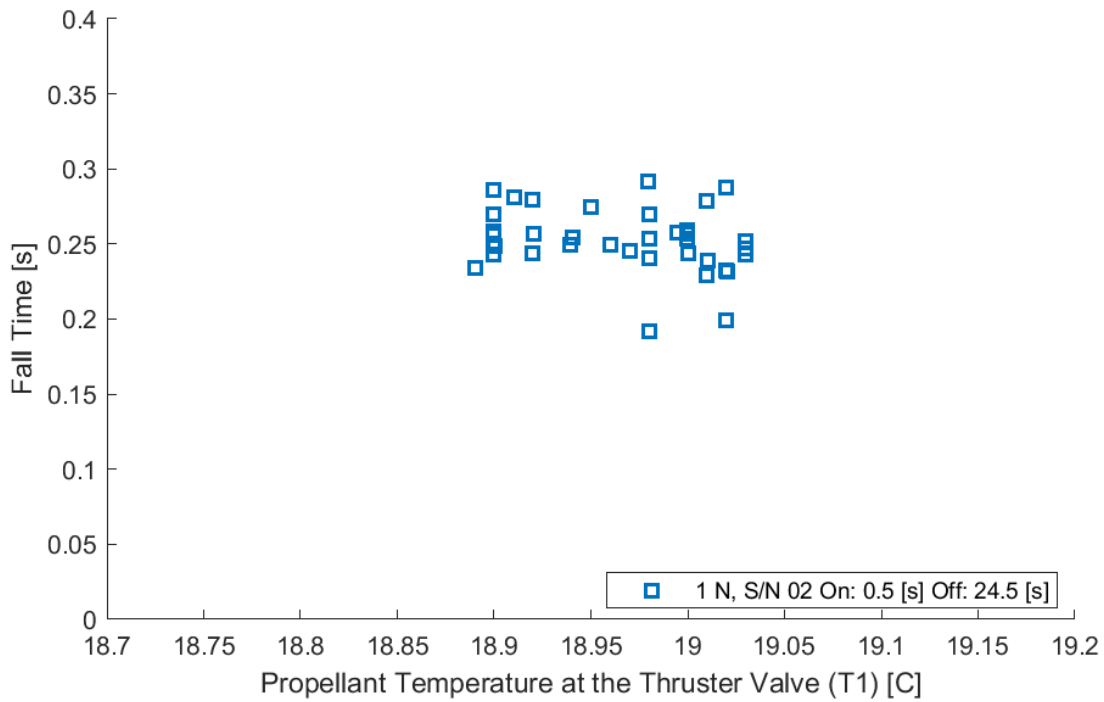

**Figure 40. Thruster valve fall time as measured by the differential pressure transducer against the propellant temperature measured at T1 for 1 N thruster valves at 125 psig reservoir head pressure.**

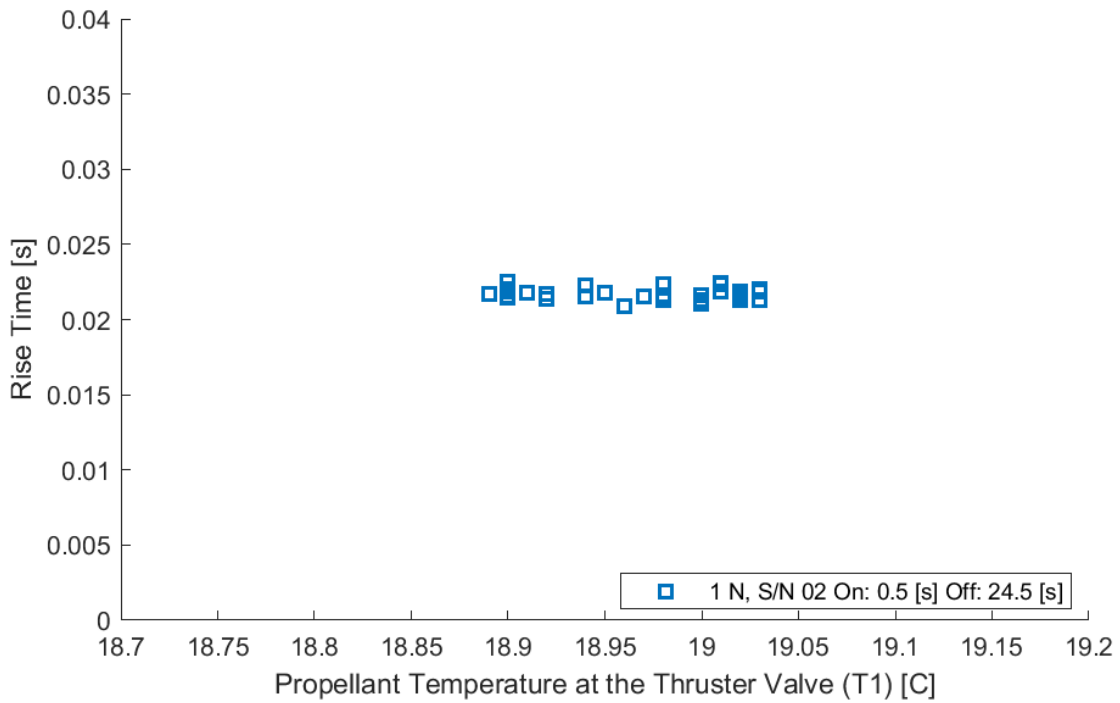

**Figure 41. Thruster valve rise time as measured by the oscilloscope against the propellant temperature measured at T1 for 1 N thruster valves at 125 psig reservoir head pressure.**

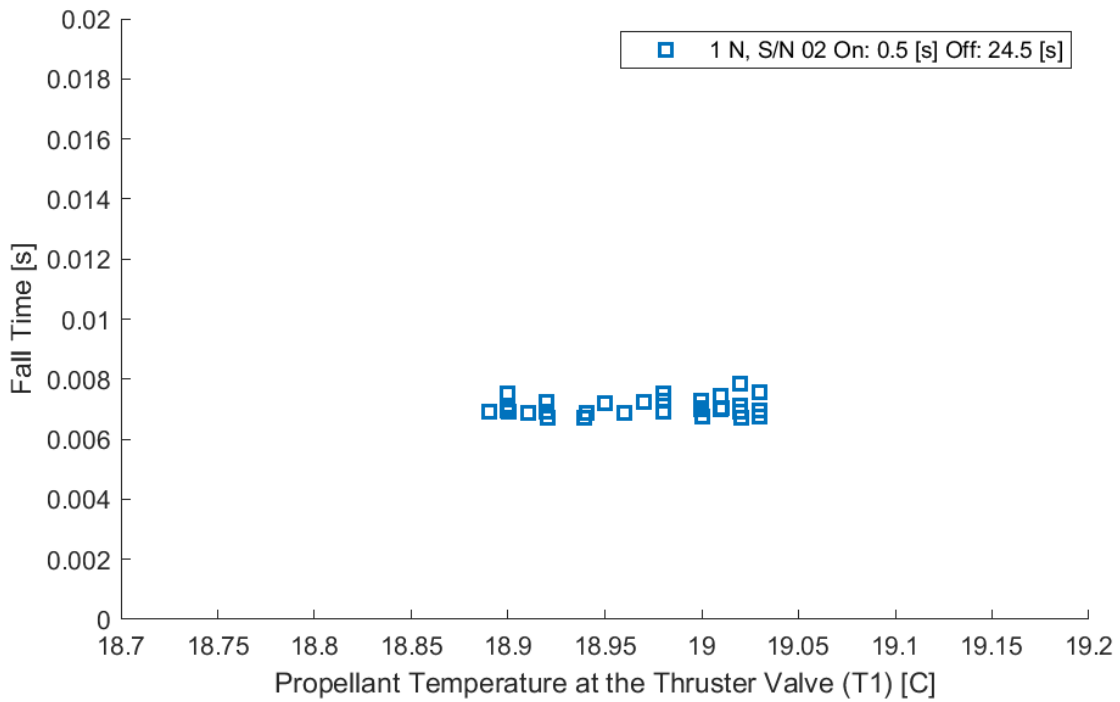

**Figure 42. Thruster valve fall time as measured by the oscilloscope against the propellant temperature measured at T1 for 1 N thruster valves at 125 psig reservoir head pressure.**

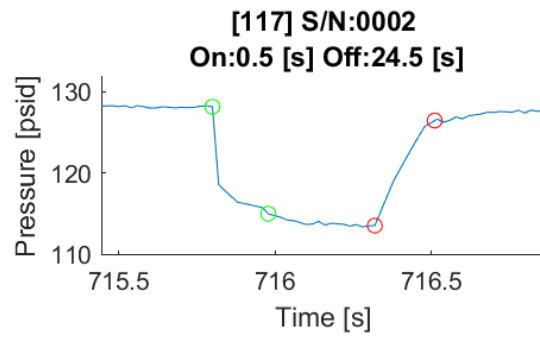

Figure 43. Thruster valve traces of the differential pressure transducer for each data set measured 1 N thruster valves at 125 psig reservoir head pressure.

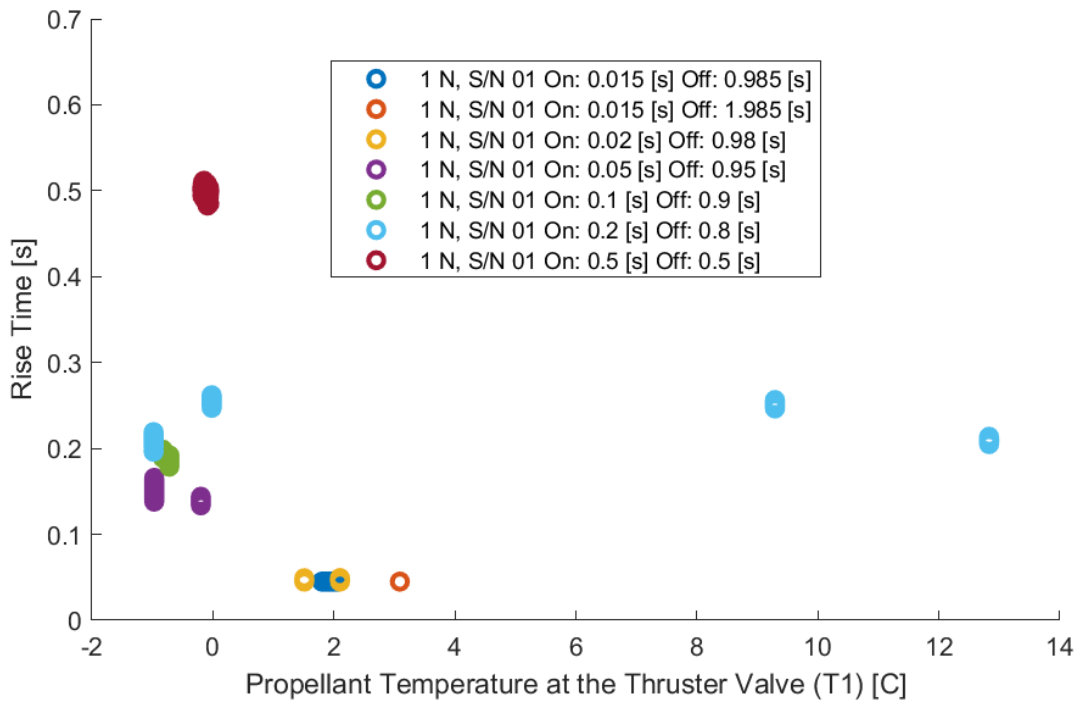
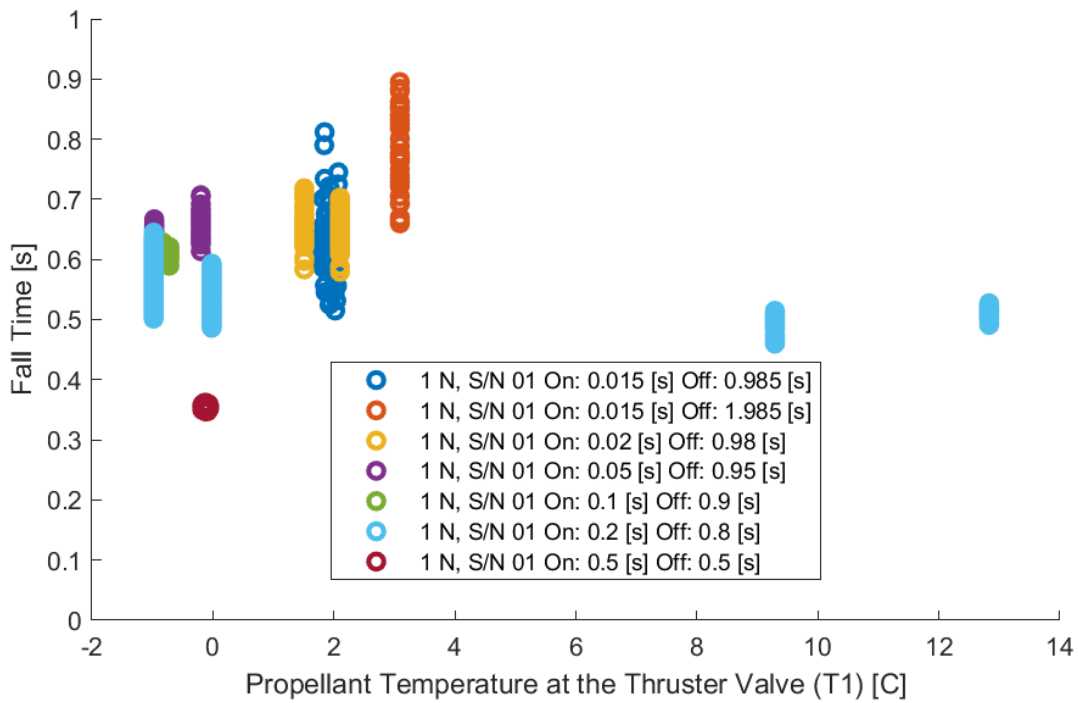
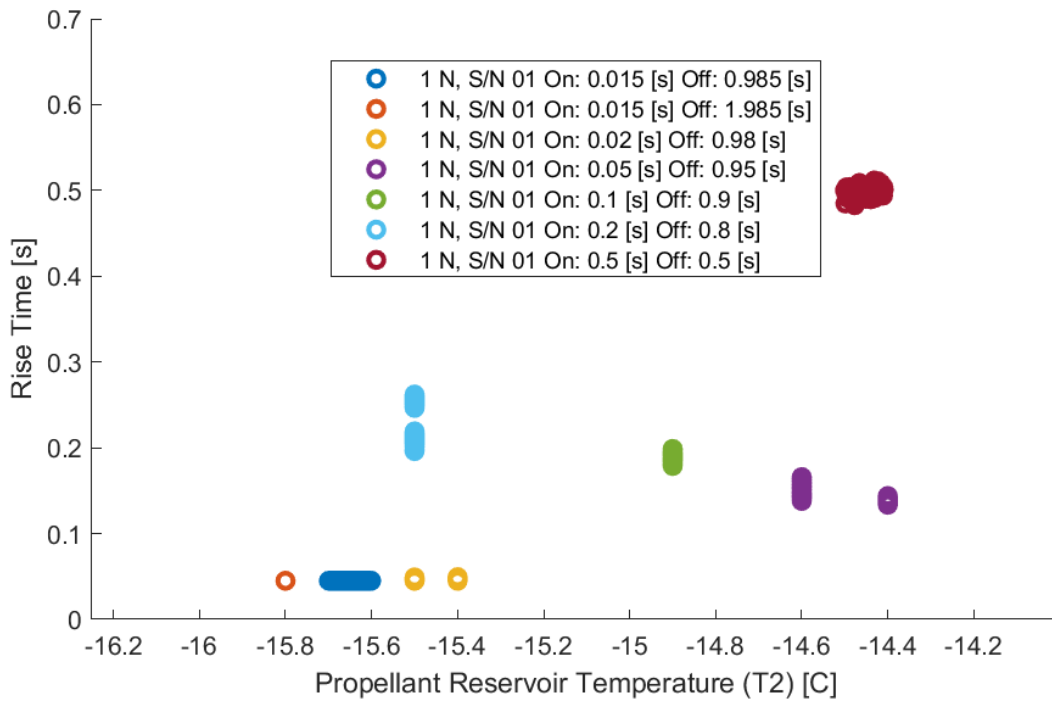

Figure 44. Thruster valve rise time as measured by the differential pressure transducer against the propellant temperature measured at T1 for 1 N thruster valves at 150 psig reservoir head pressure.



**Figure 45. Thruster valve fall time as measured by the differential pressure transducer against the propellant temperature measured at T1 for 1 N thruster valves at 150 psig reservoir head pressure.**



**Figure 46. Thruster valve rise time as measured by the differential pressure transducer against the propellant reservoir temperature measured at T2 for 1 N thruster valves at 150 psig reservoir head pressure.**

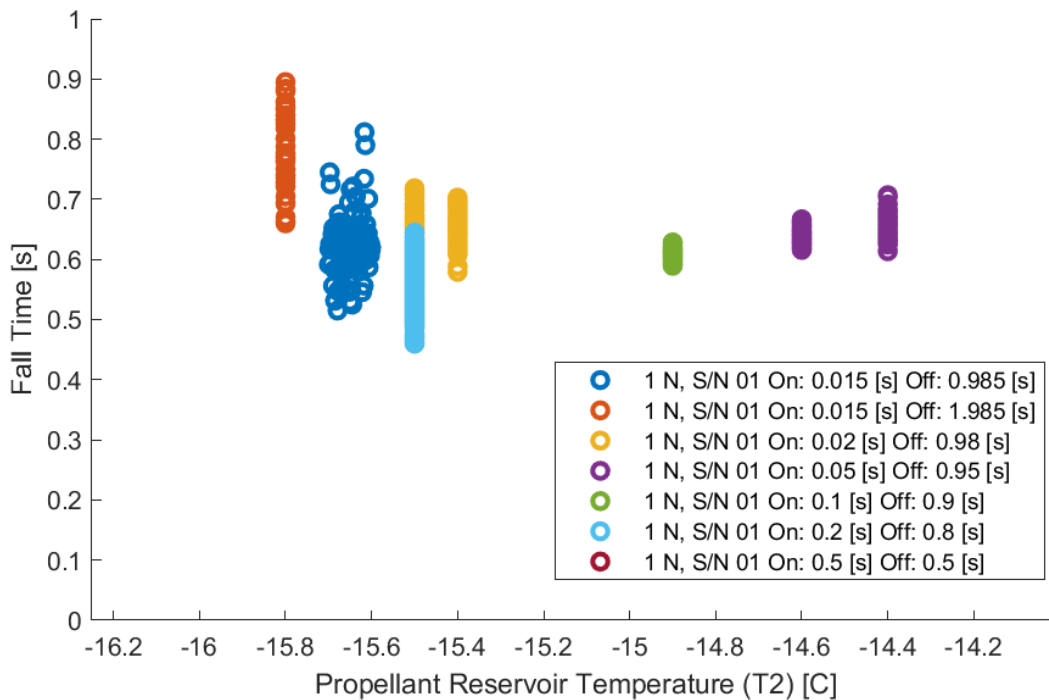

**Figure 47. Thruster valve fall time as measured by the differential pressure transducer against the propellant reservoir temperature measured at T2 for 1 N thruster valves at 150 psig reservoir head pressure.**

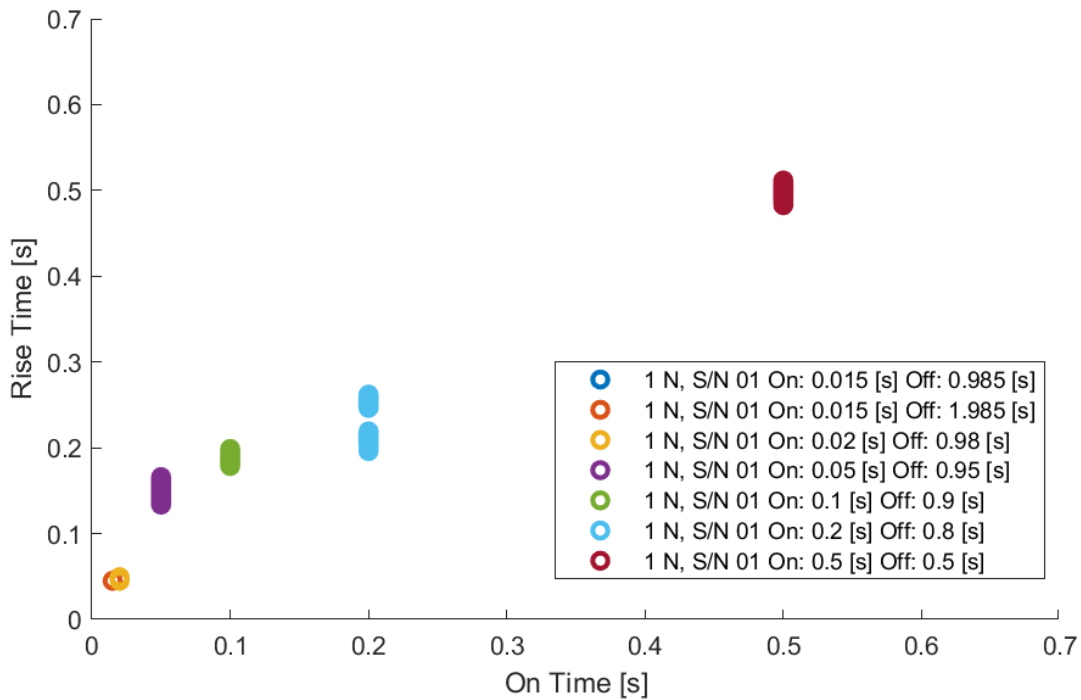

**Figure 48. Thruster valve rise time as measured by the differential pressure transducer against the commanded on time for 1 N thruster valves at 150 psig reservoir head pressure.**

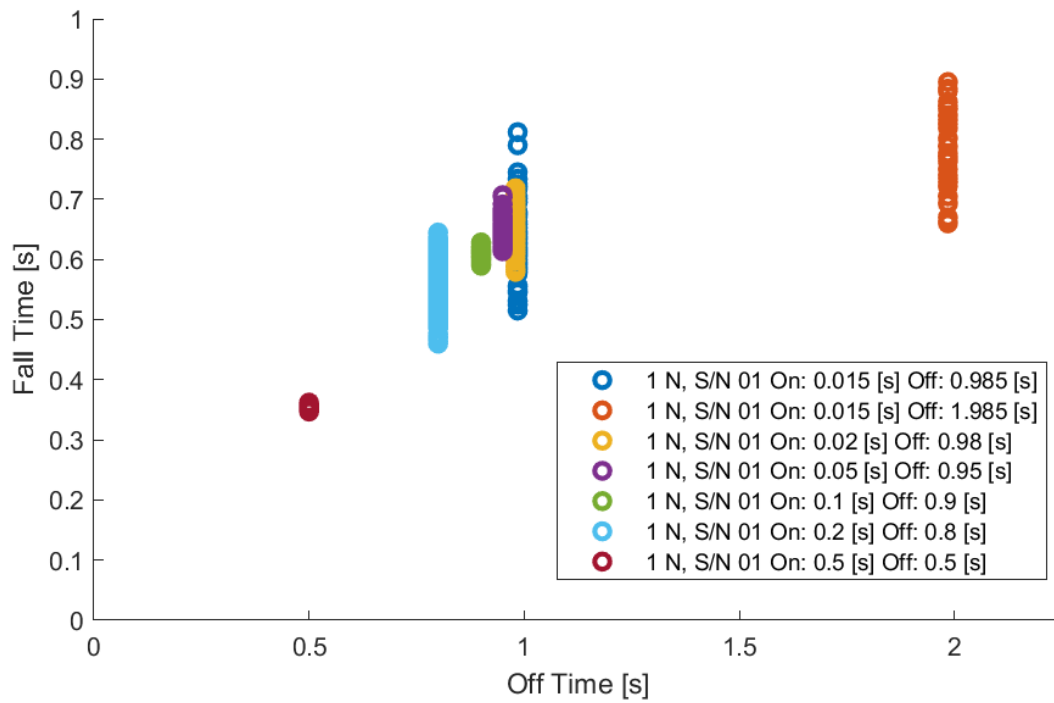

**Figure 49. Thruster valve fall time as measured by the differential pressure transducer against the off time for 1 N thruster valves at 150 psig reservoir head pressure.**

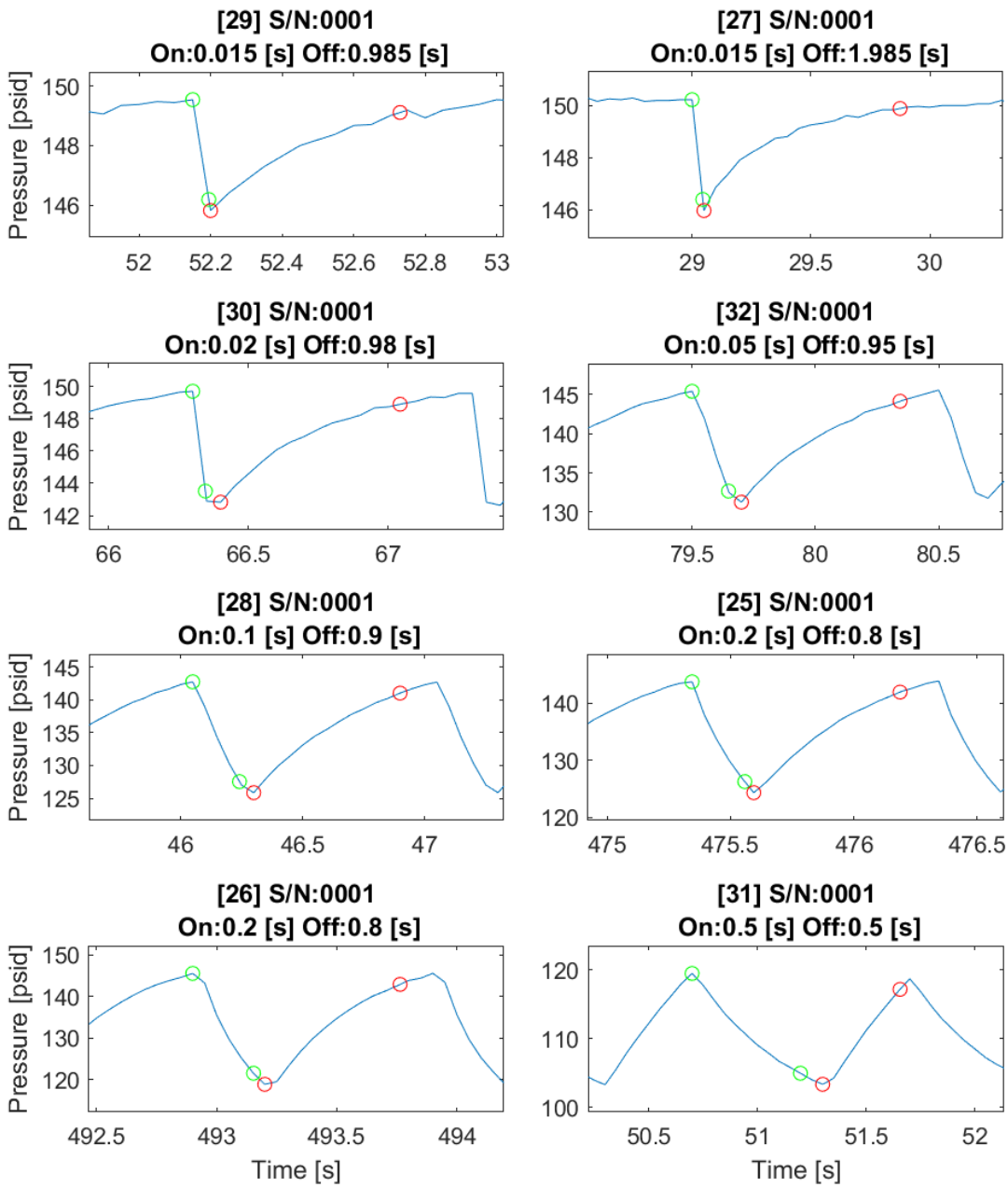

**Figure 50. Thruster valve traces of the differential pressure transducer for each data set measured 1 N thruster valves at 150 psig reservoir head pressure.**

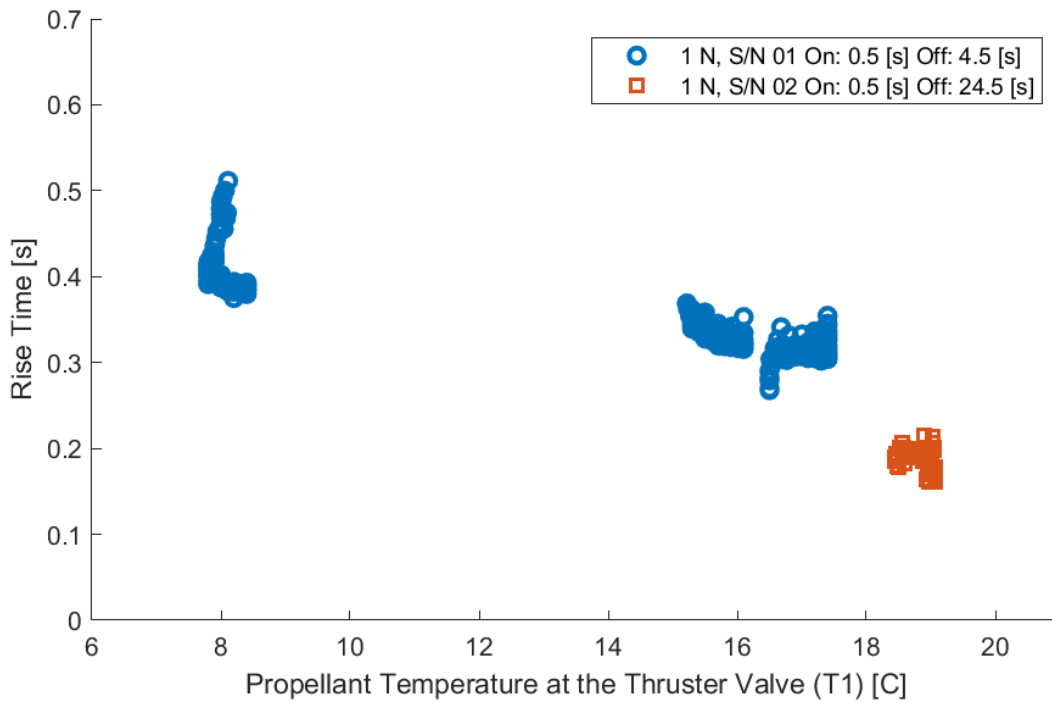

**Figure 51. Thruster valve rise time as measured by the differential pressure transducer against the propellant temperature measured at T1 for 1 N thruster valves at 260 psig reservoir head pressure.**

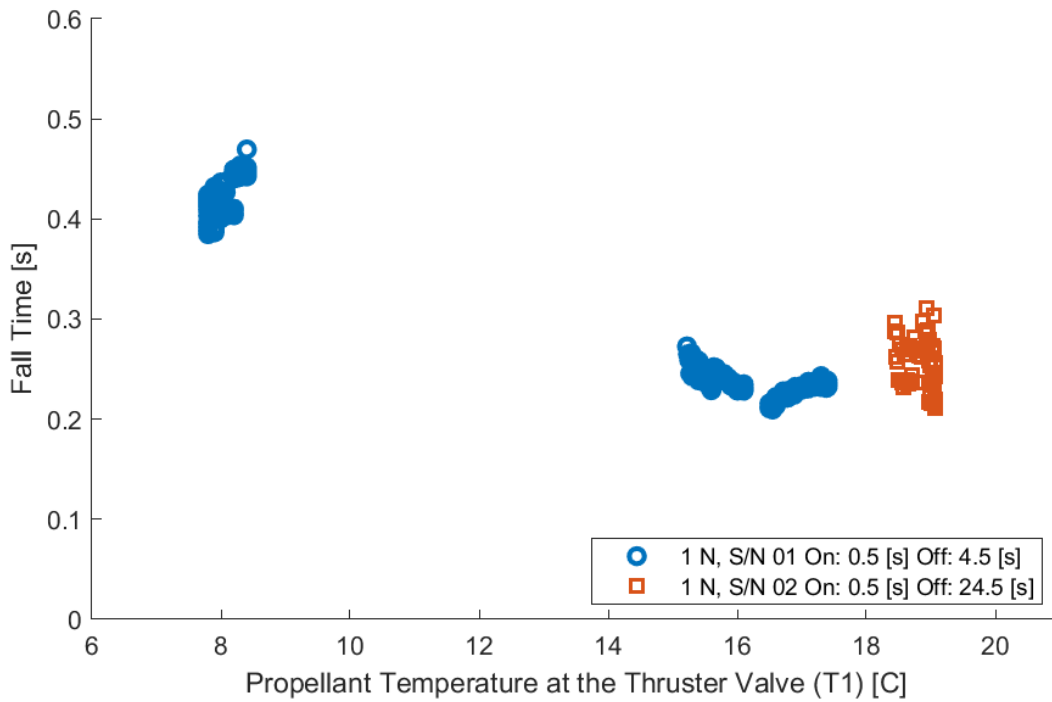

**Figure 52. Thruster valve fall time as measured by the differential pressure transducer against the propellant temperature measured at T1 for 1 N thruster valves at 260 psig reservoir head pressure.**

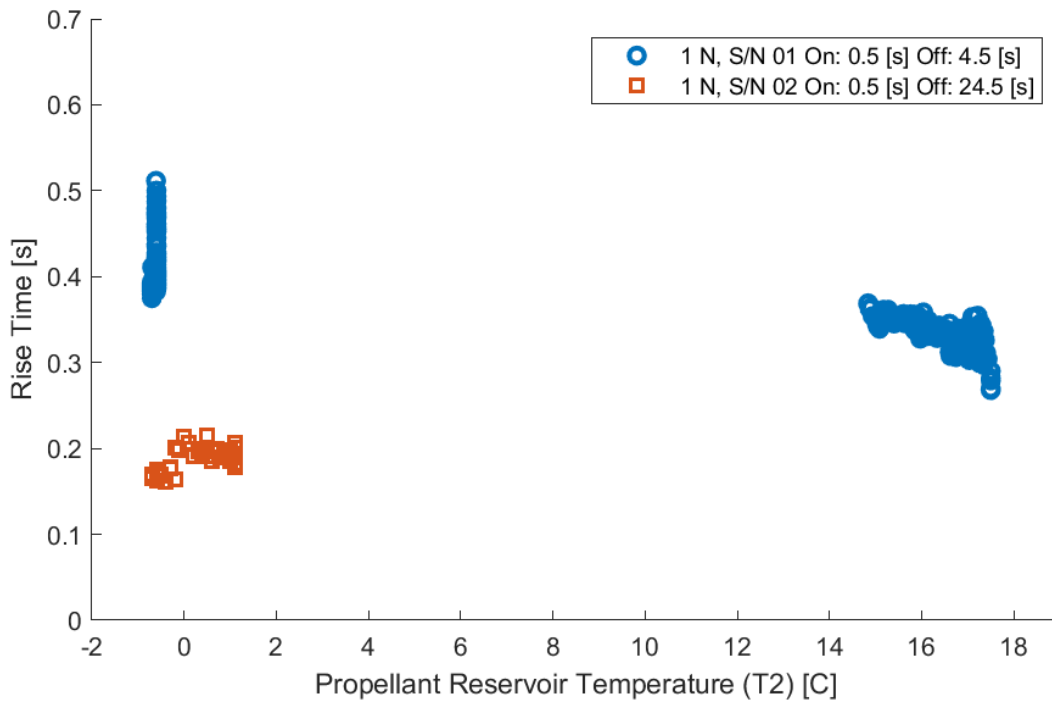

**Figure 53. Thruster valve rise time as measured by the differential pressure transducer against the propellant reservoir temperature measured at T2 for 1 N thruster valves at 260 psig reservoir head pressure.**

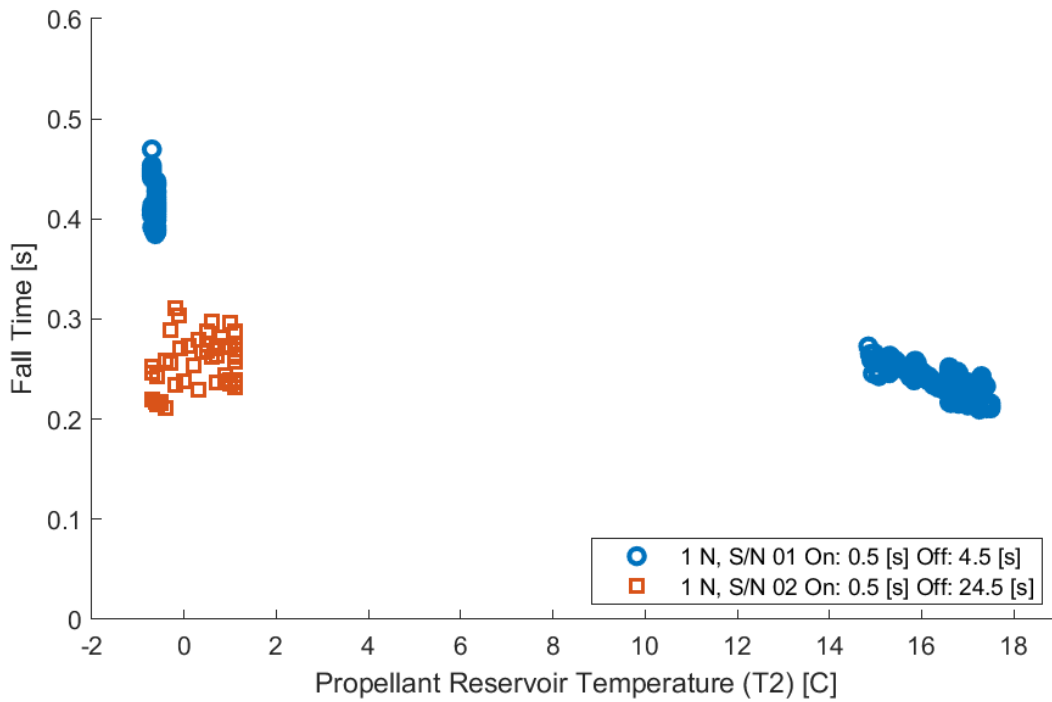

**Figure 54. Thruster valve fall time as measured by the differential pressure transducer against the propellant reservoir temperature measured at T2 for 1 N thruster valves at 260 psig reservoir head pressure.**

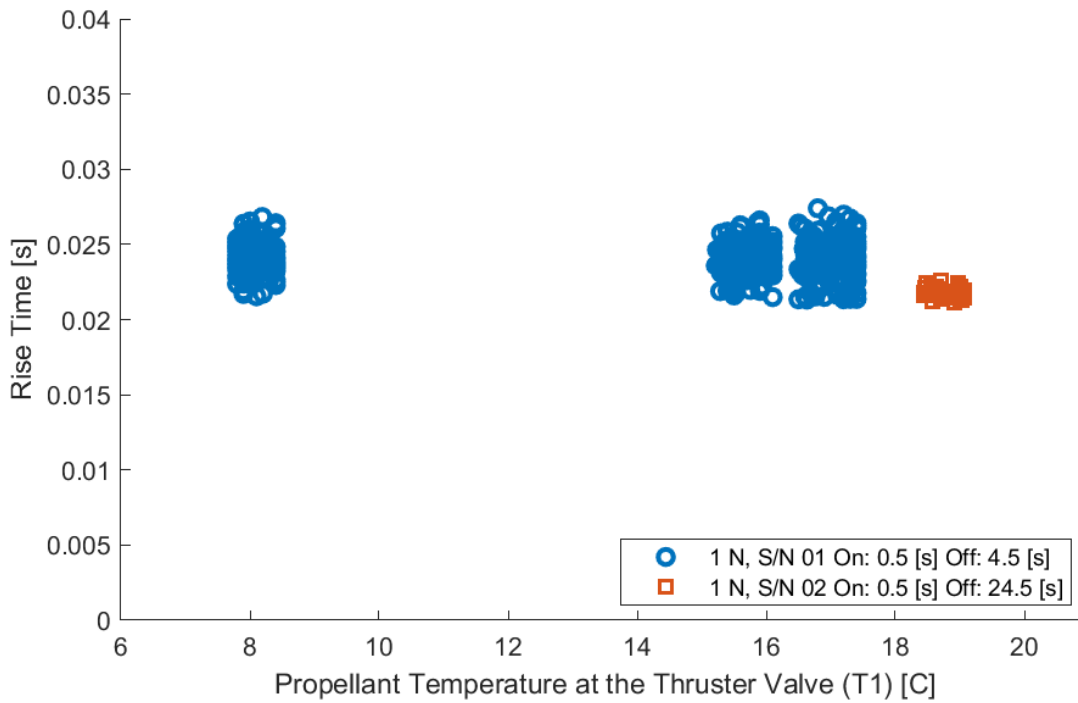

**Figure 55. Thruster valve rise time as measured by the oscilloscope against the propellant temperature measured at T1 for 1 N thruster valves at 260 psig reservoir head pressure.**

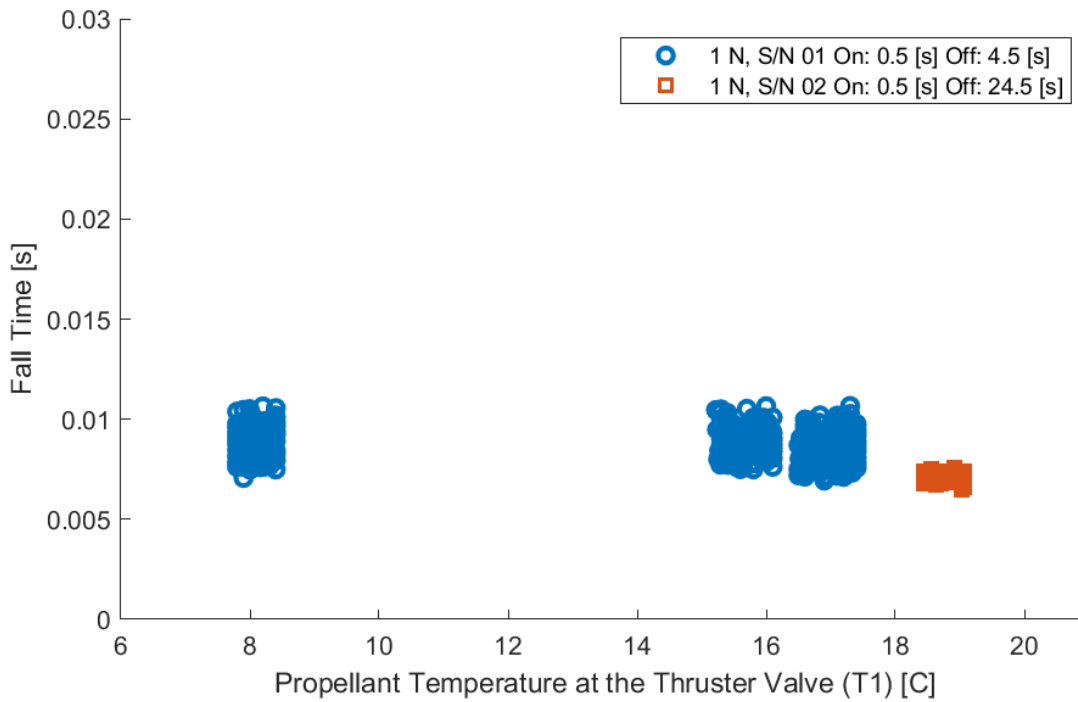

**Figure 56. Thruster valve fall time as measured by the oscilloscope against the propellant temperature measured at T1 for 1 N thruster valves at 260 psig reservoir head pressure.**

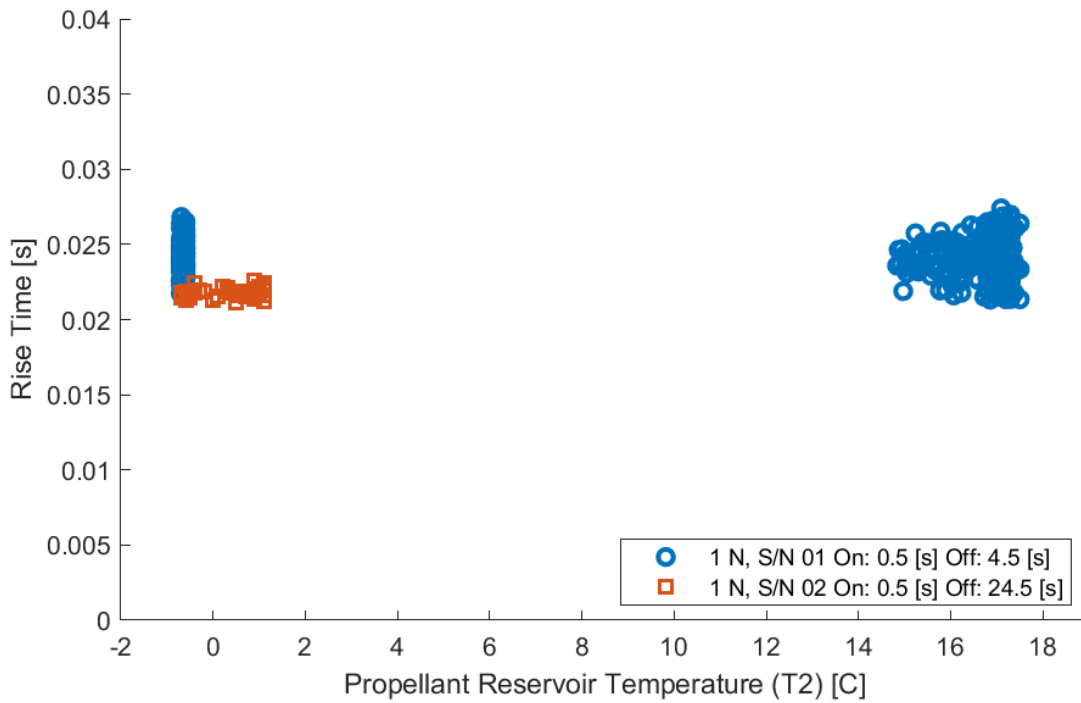

**Figure 57. Thruster valve rise time as measured by the oscilloscope against the propellant reservoir temperature measured at T2 for 1 N thruster valves at 260 psig reservoir head pressure.**

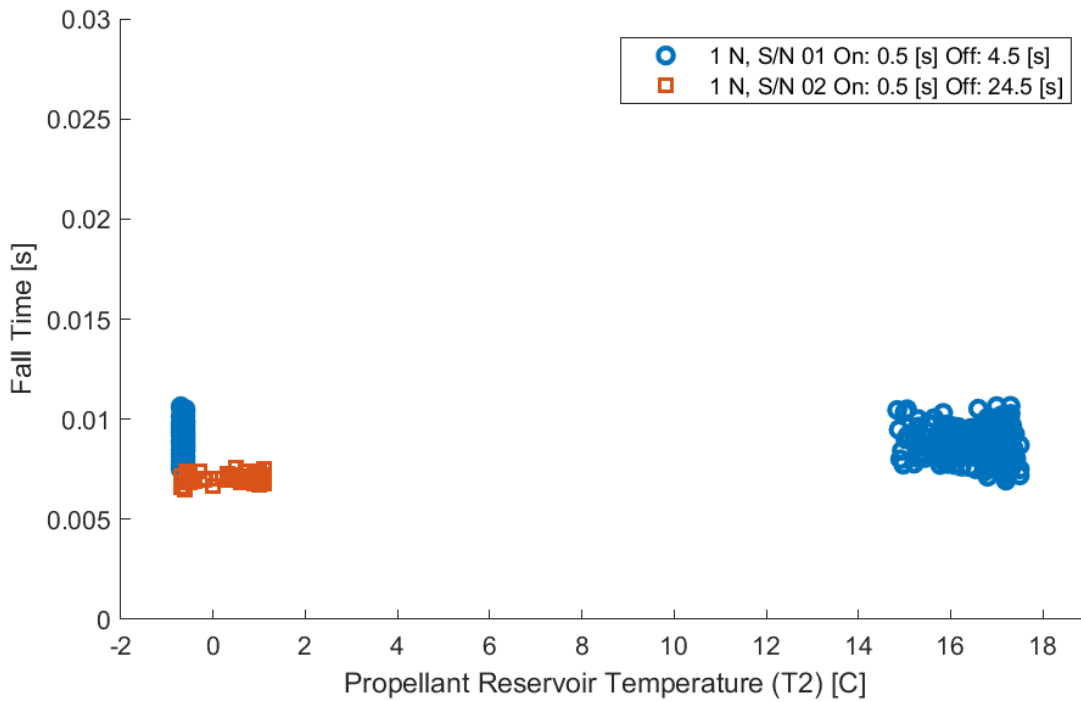

**Figure 58. Thruster valve fall time as measured by the oscilloscope against the propellant reservoir temperature measured at T2 for 1 N thruster valves at 260 psig reservoir head pressure.**

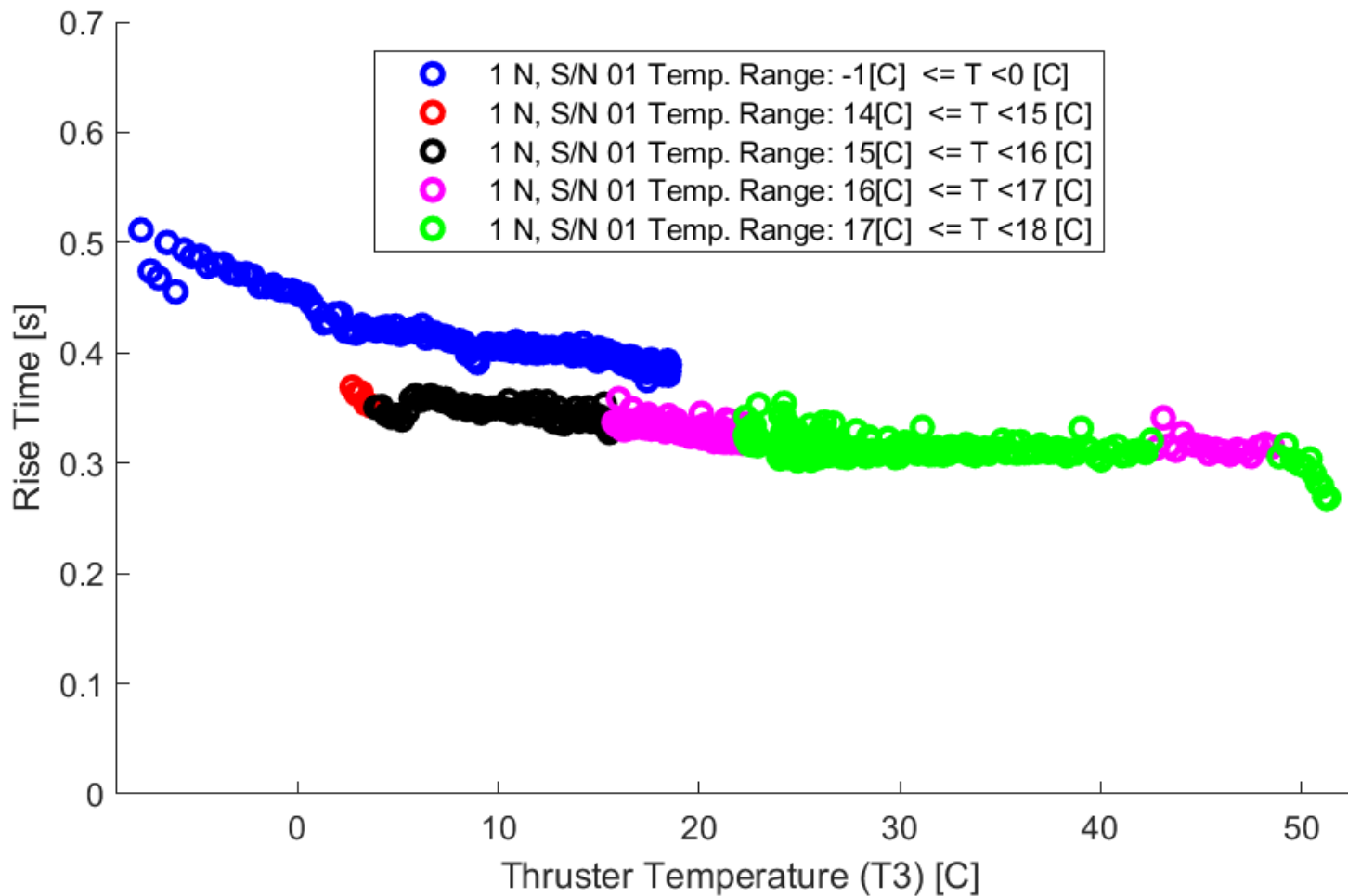

Figure 59. Thruster valve rise time as measured by the differential pressure transducer against the thruster valve body temperature measured at T3 for 1 N thruster valves at 260 psig reservoir head pressure. Gradients were added to show the variations due to the propellant reservoir temperature measured at T2.

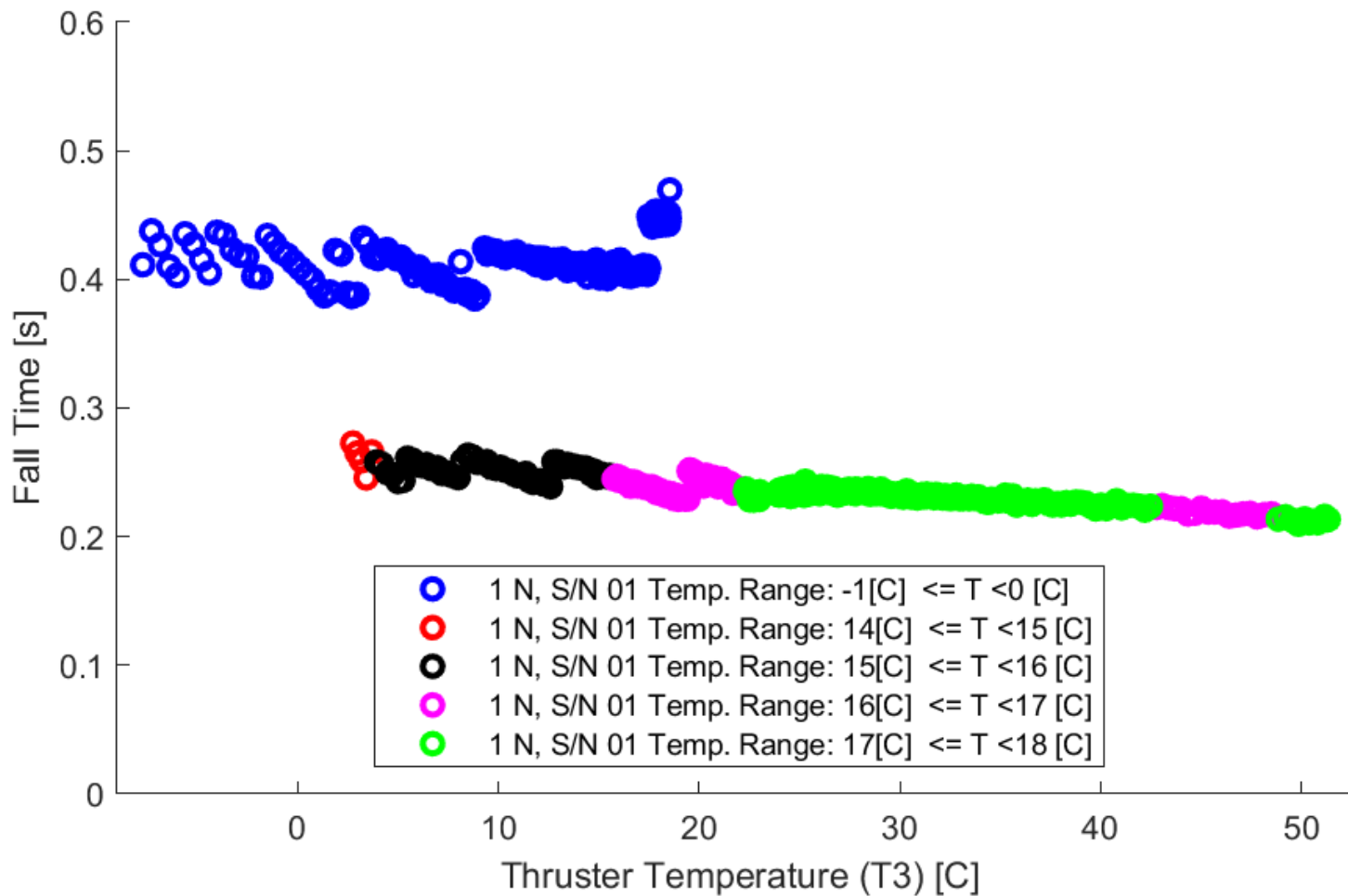
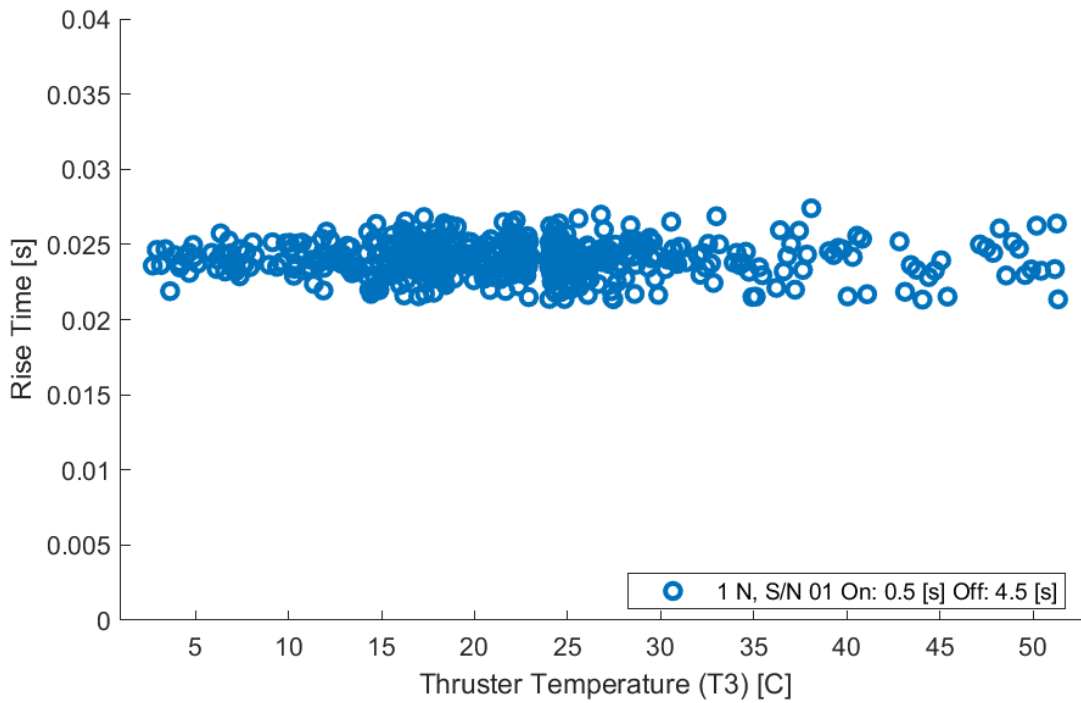
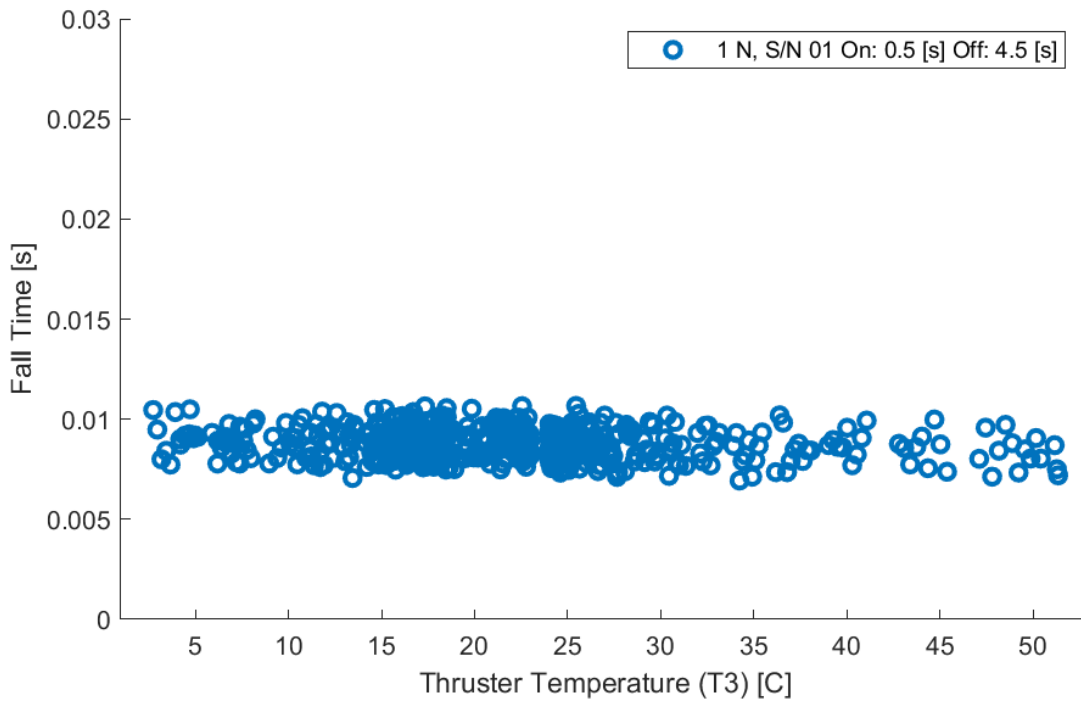

Figure 60. Thruster valve fall time as measured by the differential pressure transducer against the thruster valve body temperature measured at T3 for 1 N thruster valves at 260 psig reservoir head pressure. Gradients were added to show the variations due to the propellant reservoir temperature measured at T2.



**Figure 61. Thruster valve rise time as measured by the oscilloscope against the thruster valve body temperature measured at T3 for 1 N thruster valves at 260 psig reservoir head pressure.**



**Figure 62. Thruster valve fall time as measured by the oscilloscope against the thruster valve body temperature measured at T3 for 1 N thruster valves at 260 psig reservoir head pressure.**

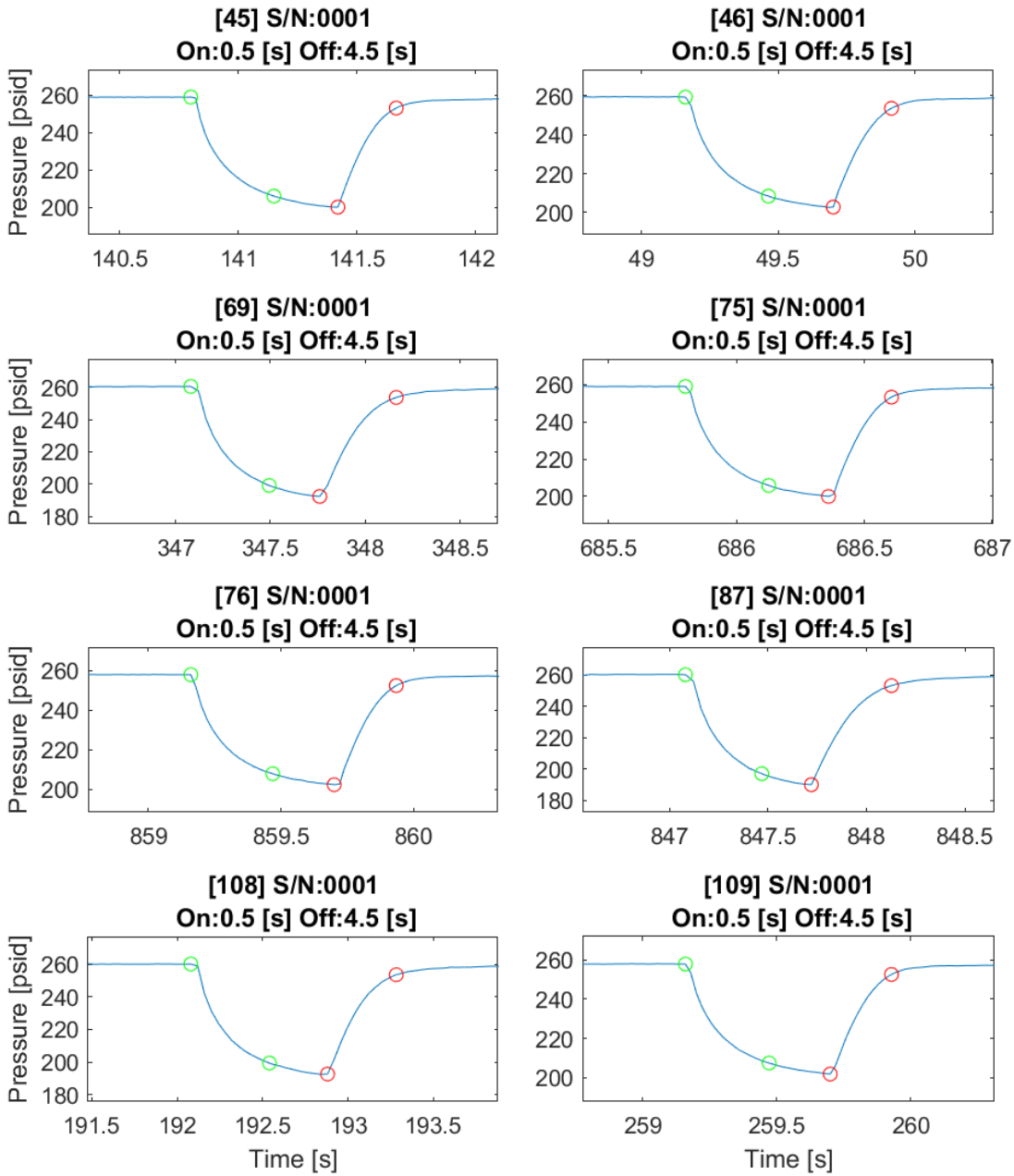

Figure 63. Thruster valve traces of the differential pressure transducer for each data set measured 1 N thruster valves at 260 psig reservoir head pressure.

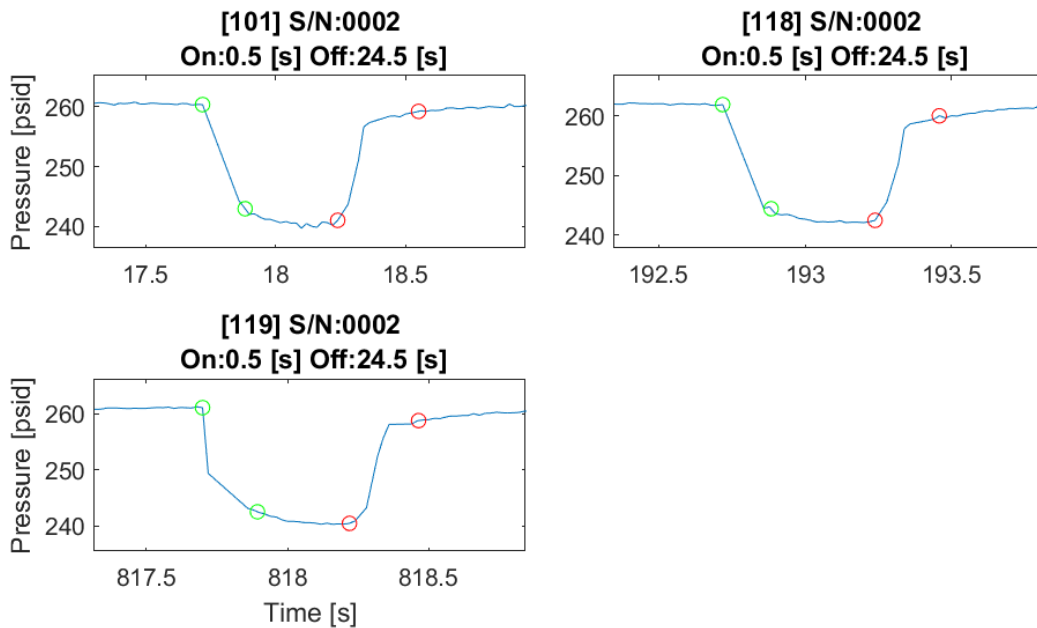

Figure 64. Thruster valve traces of the differential pressure transducer for each data set measured 1 N thruster valves at 260 psig reservoir head pressure.

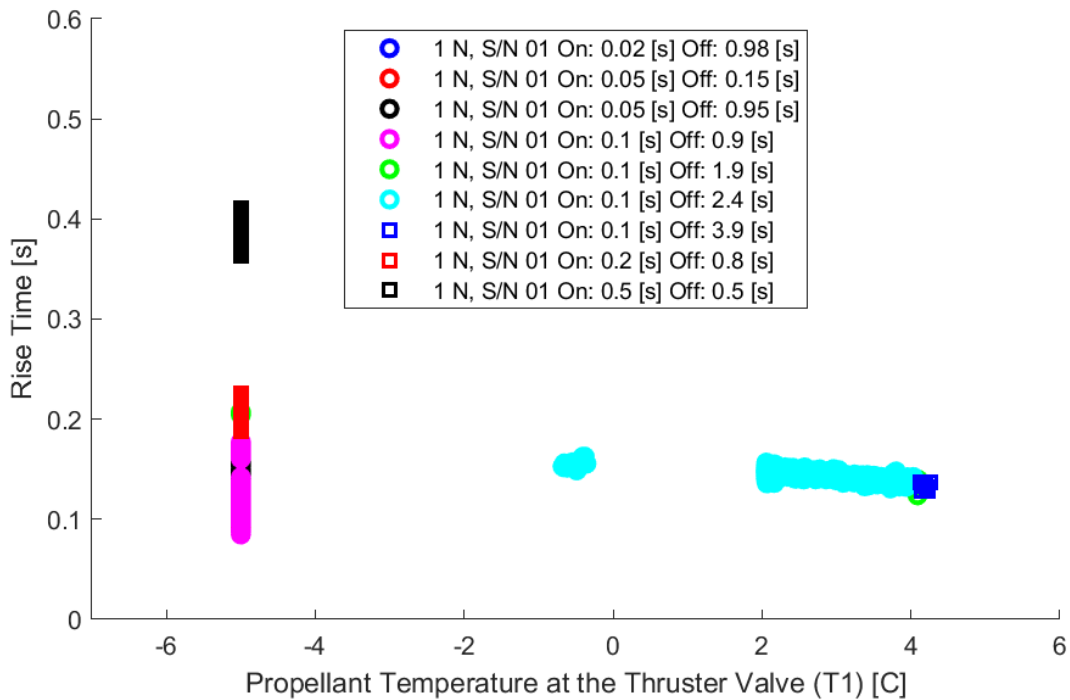
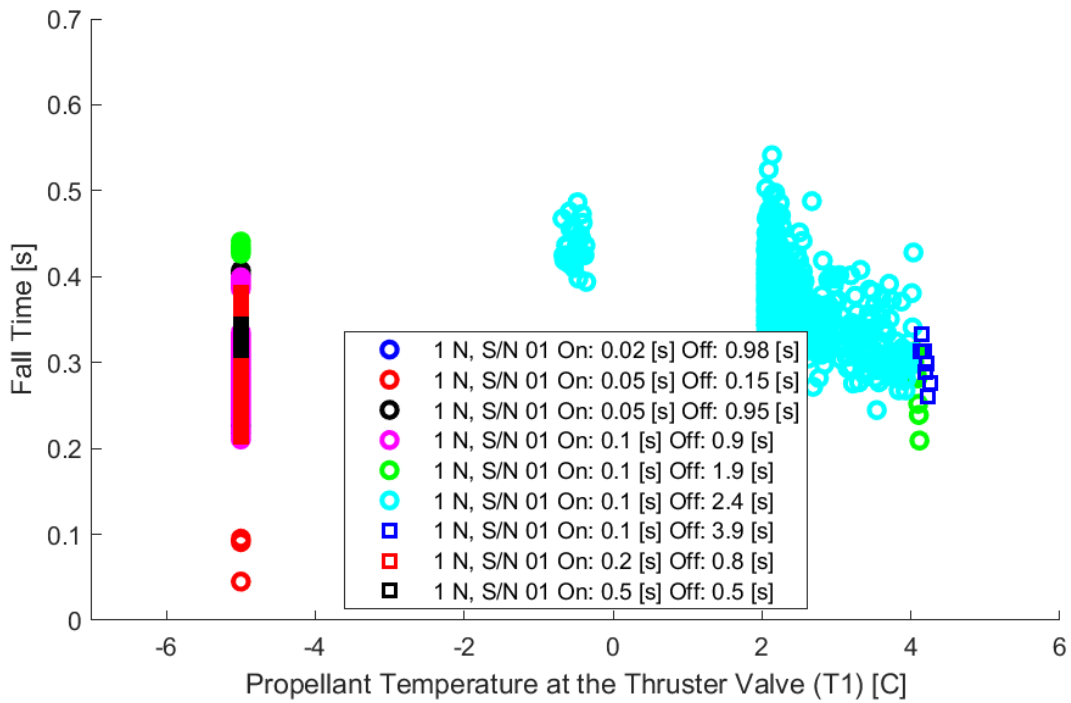
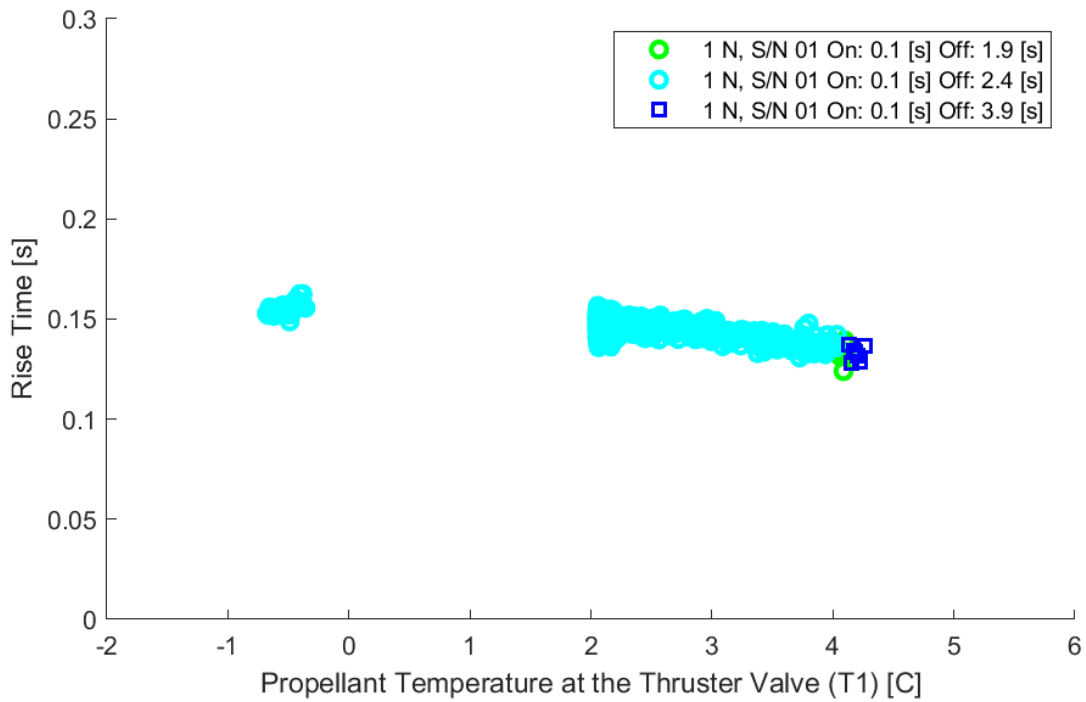

Figure 65. Thruster valve rise time as measured by the differential pressure transducer against the propellant temperature measured at T1 for 1 N thruster valves at 280 psig reservoir head pressure.



**Figure 66. Thruster valve fall time as measured by the differential pressure transducer against the propellant temperature measured at T1 for 1 N thruster valves at 280 psig reservoir head pressure.**



**Figure 67. Thruster valve rise time as measured by the differential pressure transducer against the temperature measured at T1 where temperature T2 was measured for 1 N thruster valves at 280 psig head pressure.**

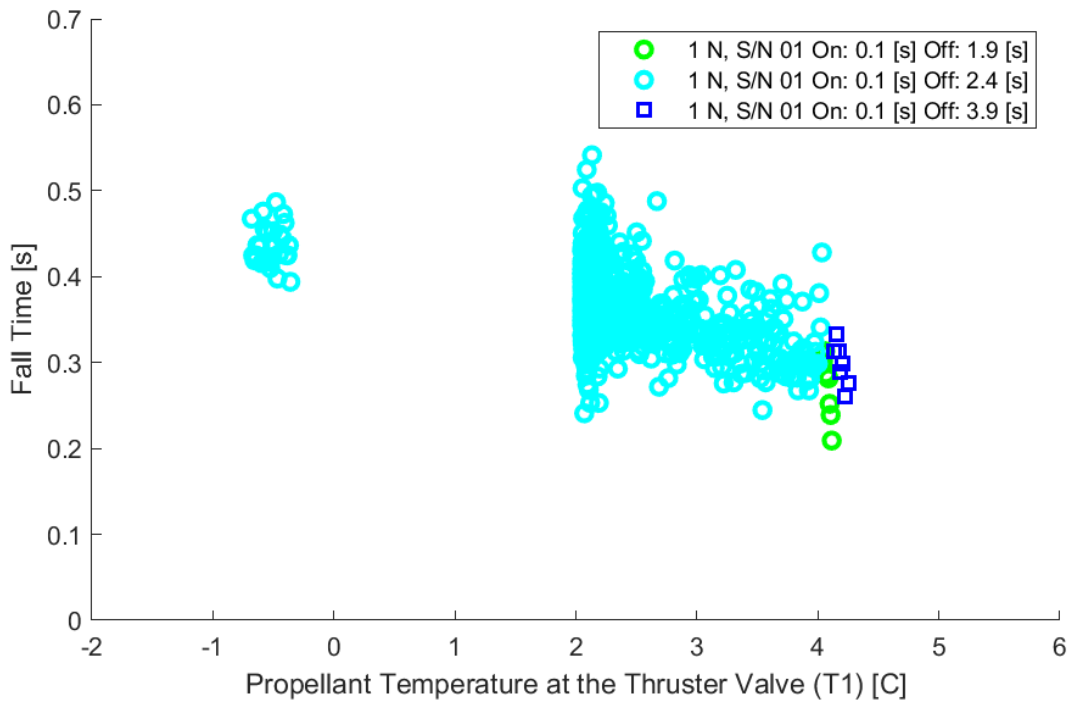

**Figure 68. Thruster valve fall time as measured by the differential pressure transducer against the measured at T1 where temperature T2 was measured for 1 N thruster valves at 280 psig head pressure.**

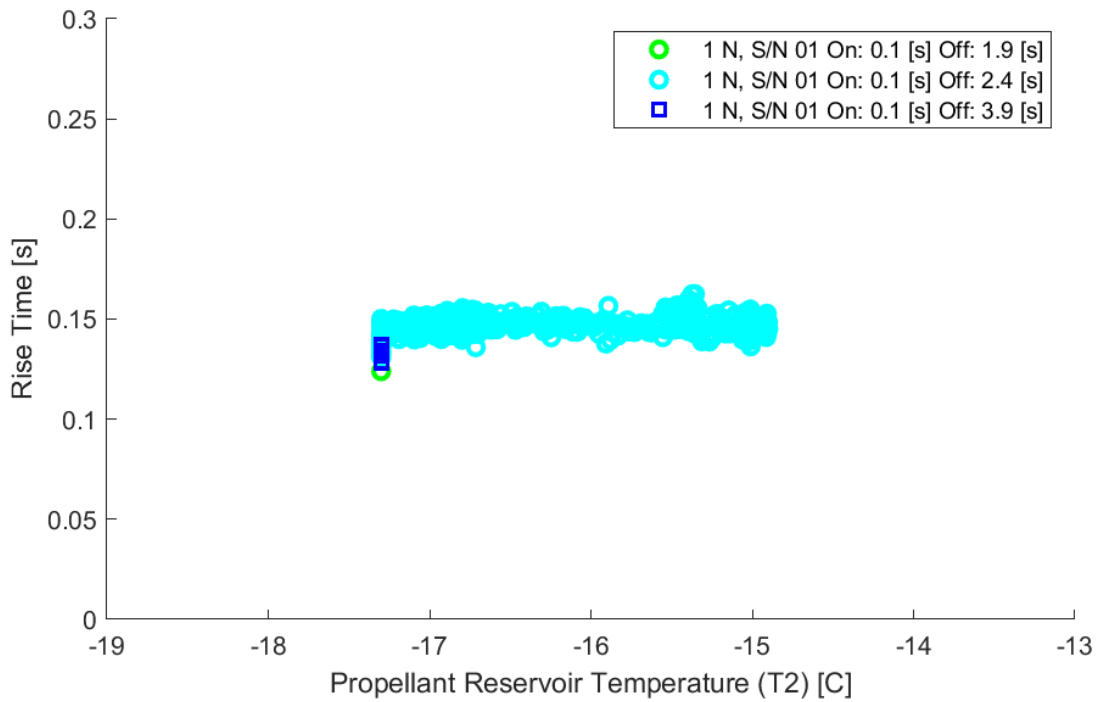

**Figure 69. Thruster valve rise time as measured by the differential pressure transducer against the propellant reservoir temperature measured at T2 for 1 N thruster valves at 280 psig reservoir head pressure.**

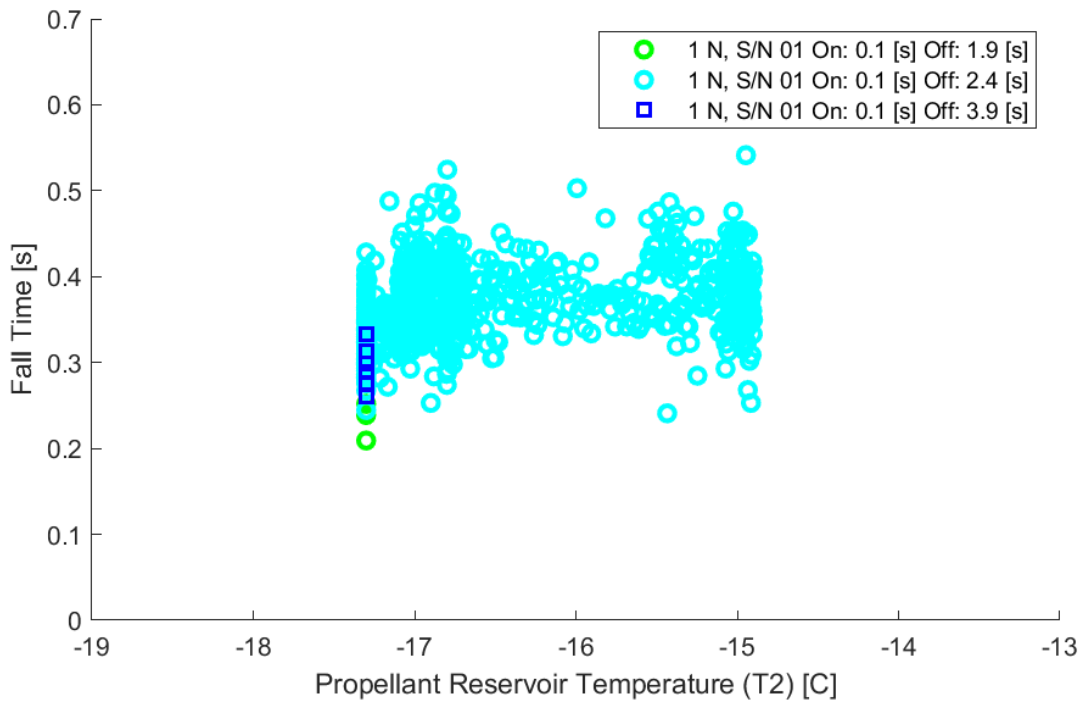

**Figure 70. Thruster valve fall time as measured by the differential pressure transducer against the propellant reservoir temperature measured at T2 for 1 N thruster valves at 280 psig reservoir head pressure.**

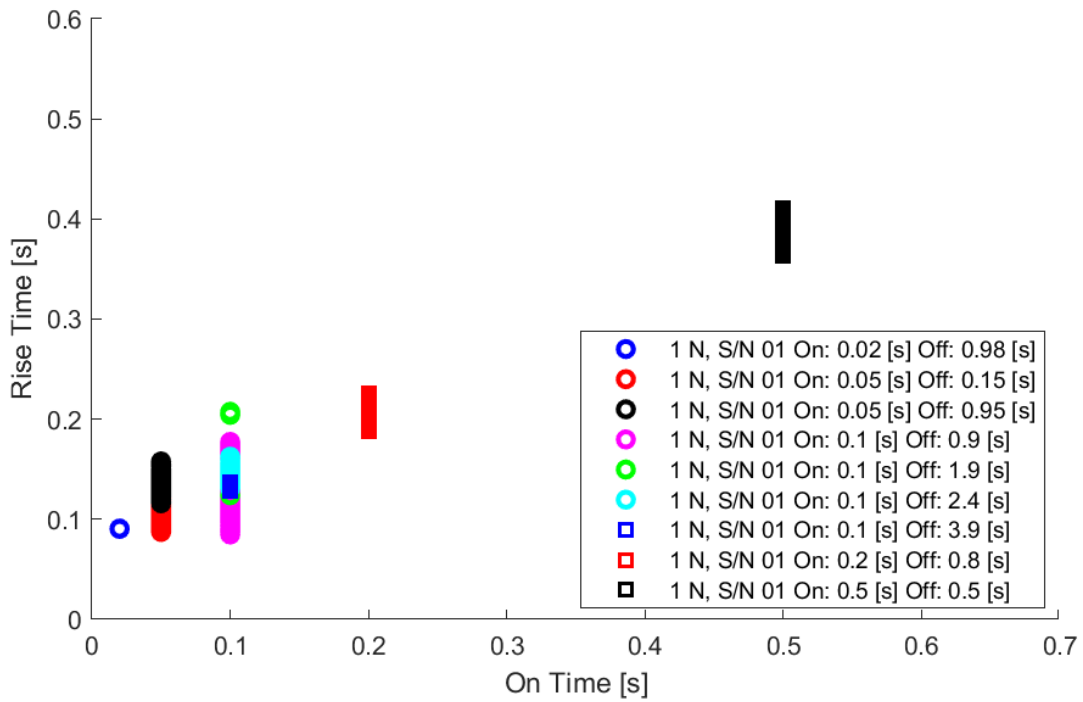

**Figure 71. Thruster valve rise time as measured by the differential pressure transducer against the commanded on time for 1 N thruster valves at 280 psig reservoir head pressure.**

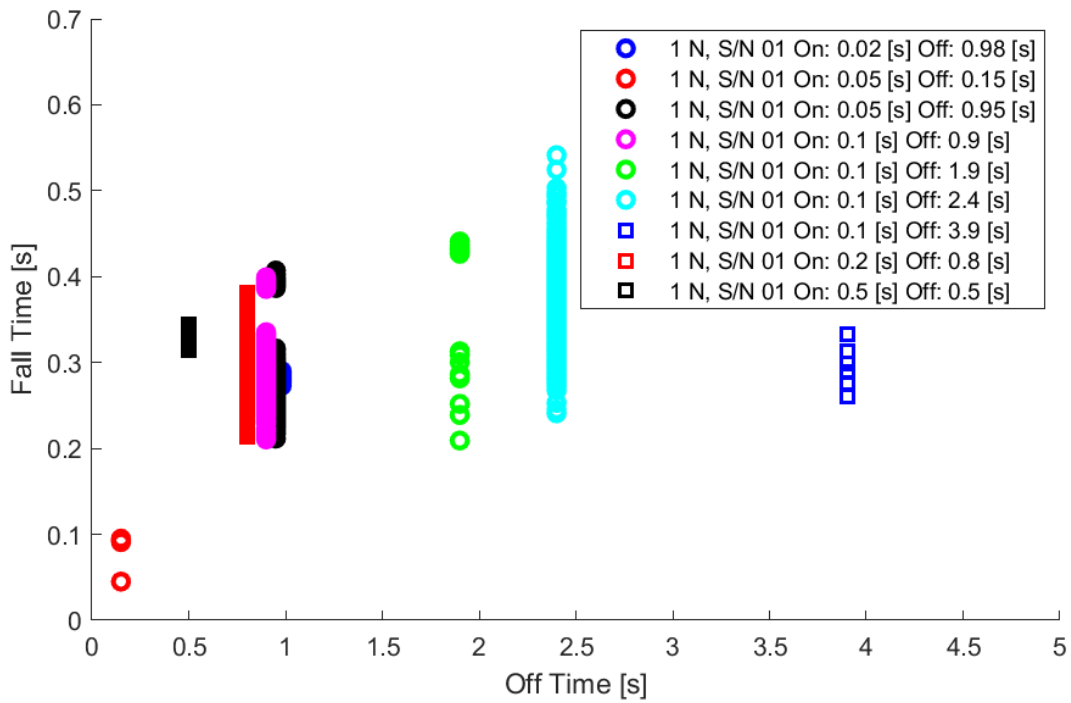

Figure 72. Thruster valve fall time as measured by the differential pressure transducer against the off time for 1 N thruster valves at 280 psig reservoir head pressure.

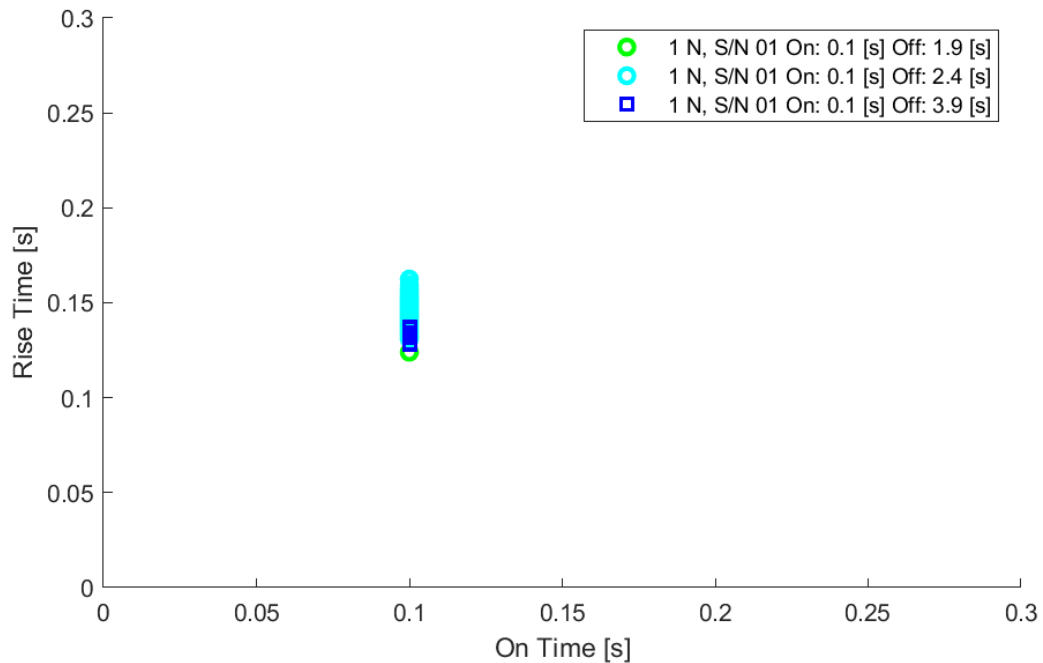
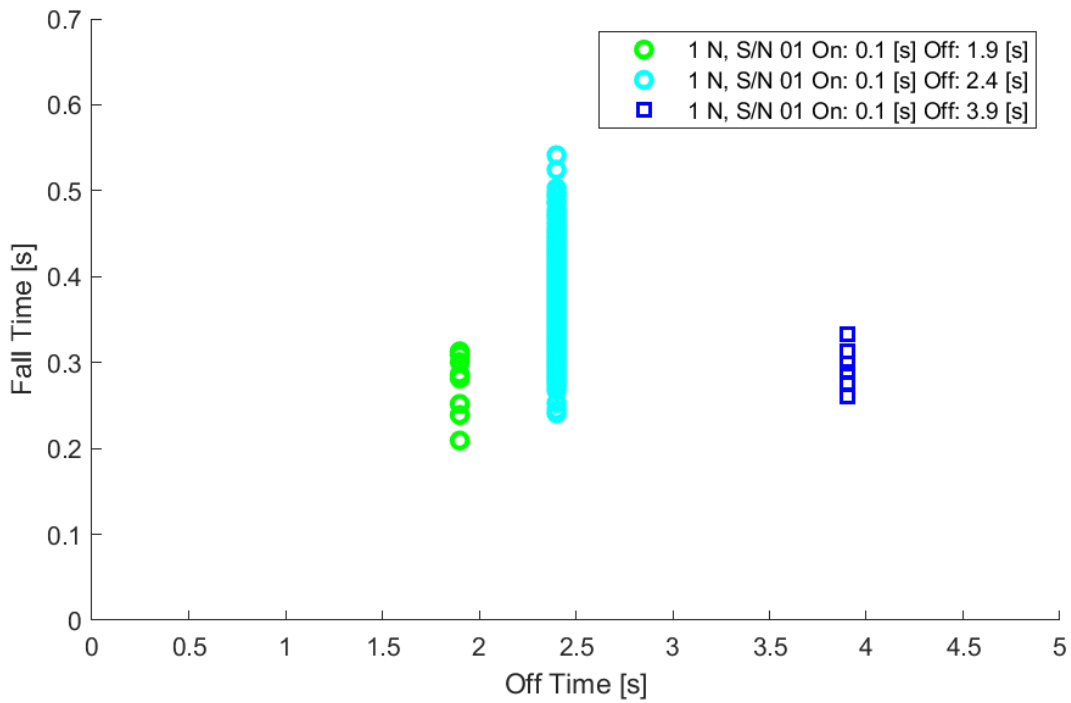
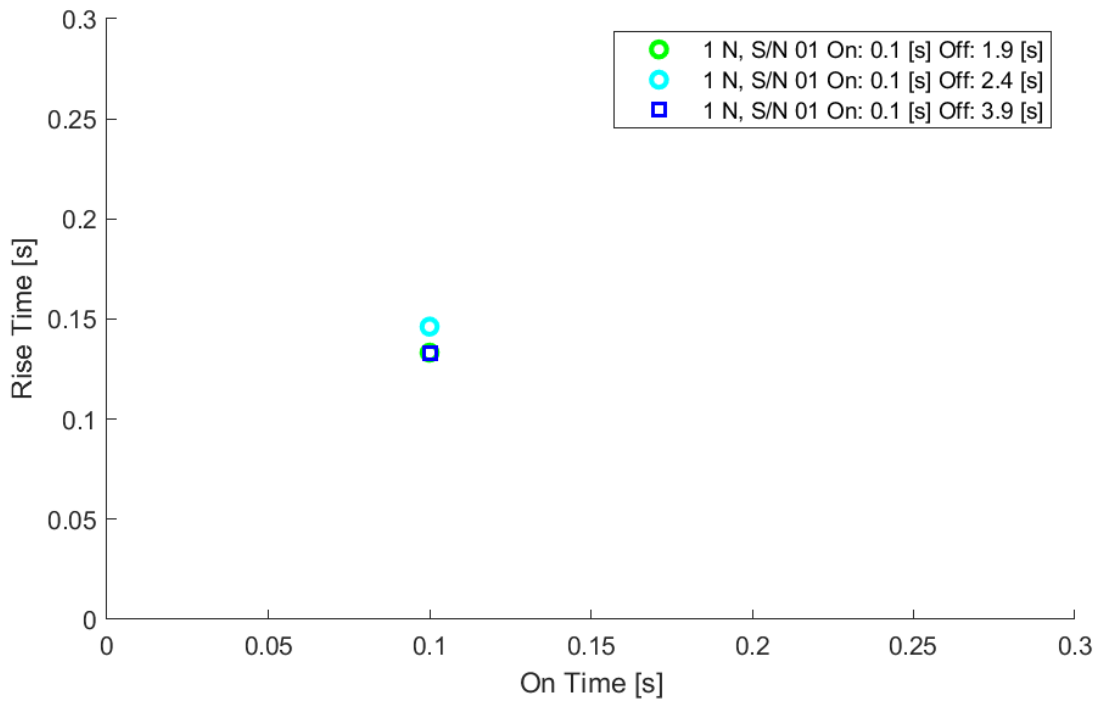

Figure 73. Thruster valve rise time as measured by the differential pressure transducer against the commanded on time where propellant reservoir temperature T2 was measured for 1 N thruster valves at 280 psig reservoir head pressure.



**Figure 74. Thruster valve fall time as measured by the differential pressure transducer against the off time where reservoir temperature T2 was measured for 1 N thruster valves at 280 psig head pressure.**



**Figure 75. Thruster valve fall time as measured by the differential pressure transducer against the off time where reservoir temperature T2 was measured for 1 N thruster valves at 280 psig head pressure.**

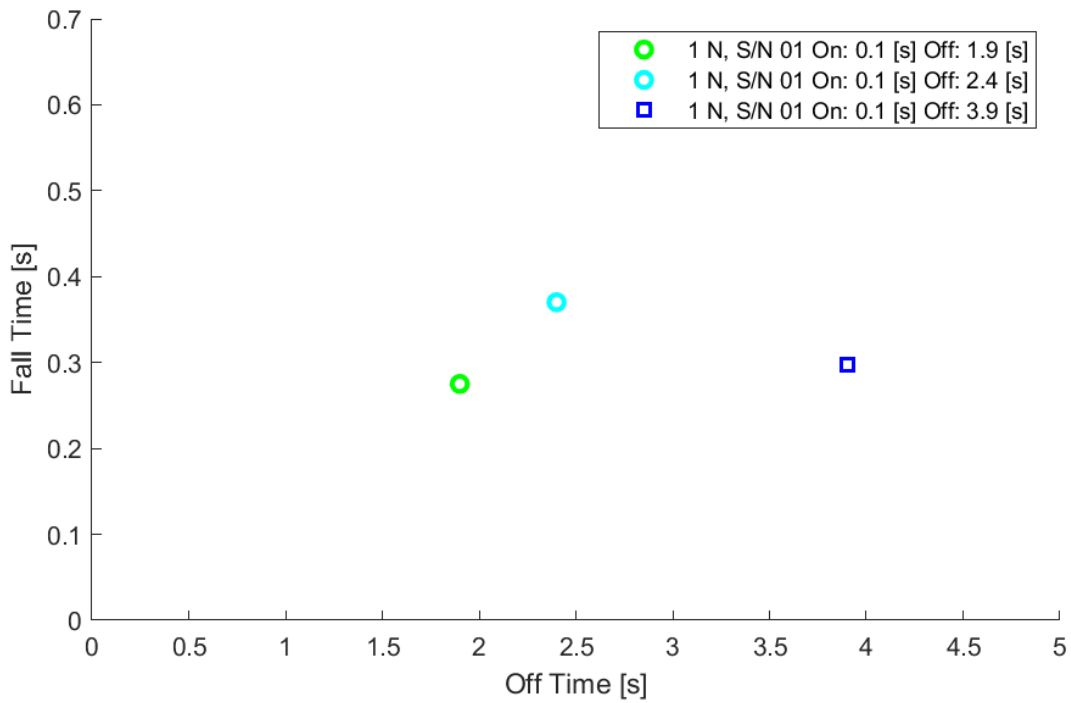

**Figure 76. Thruster valve average rise time as measured by the differential pressure transducer against the commanded on time where temperature T2 was measured for 1 N thruster valves at 280 psig head pressure.**

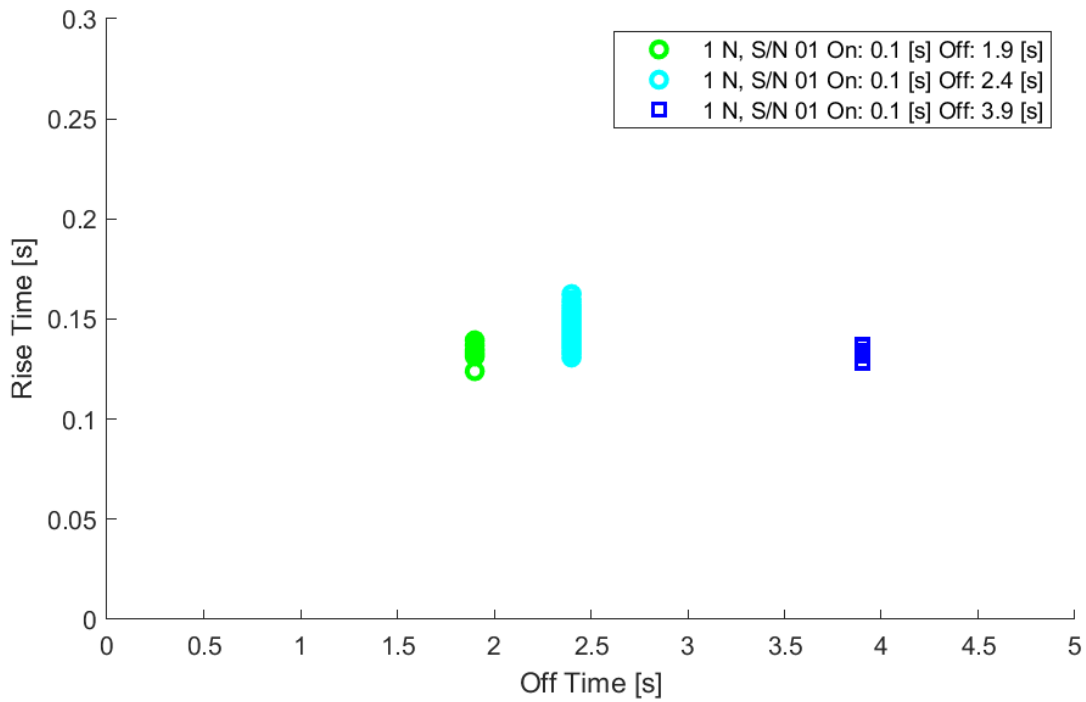

**Figure 77. Thruster valve rise time as measured by the differential pressure transducer against the off time where reservoir temperature T2 was measured for 1 N thruster valves at 280 psig head pressure.**

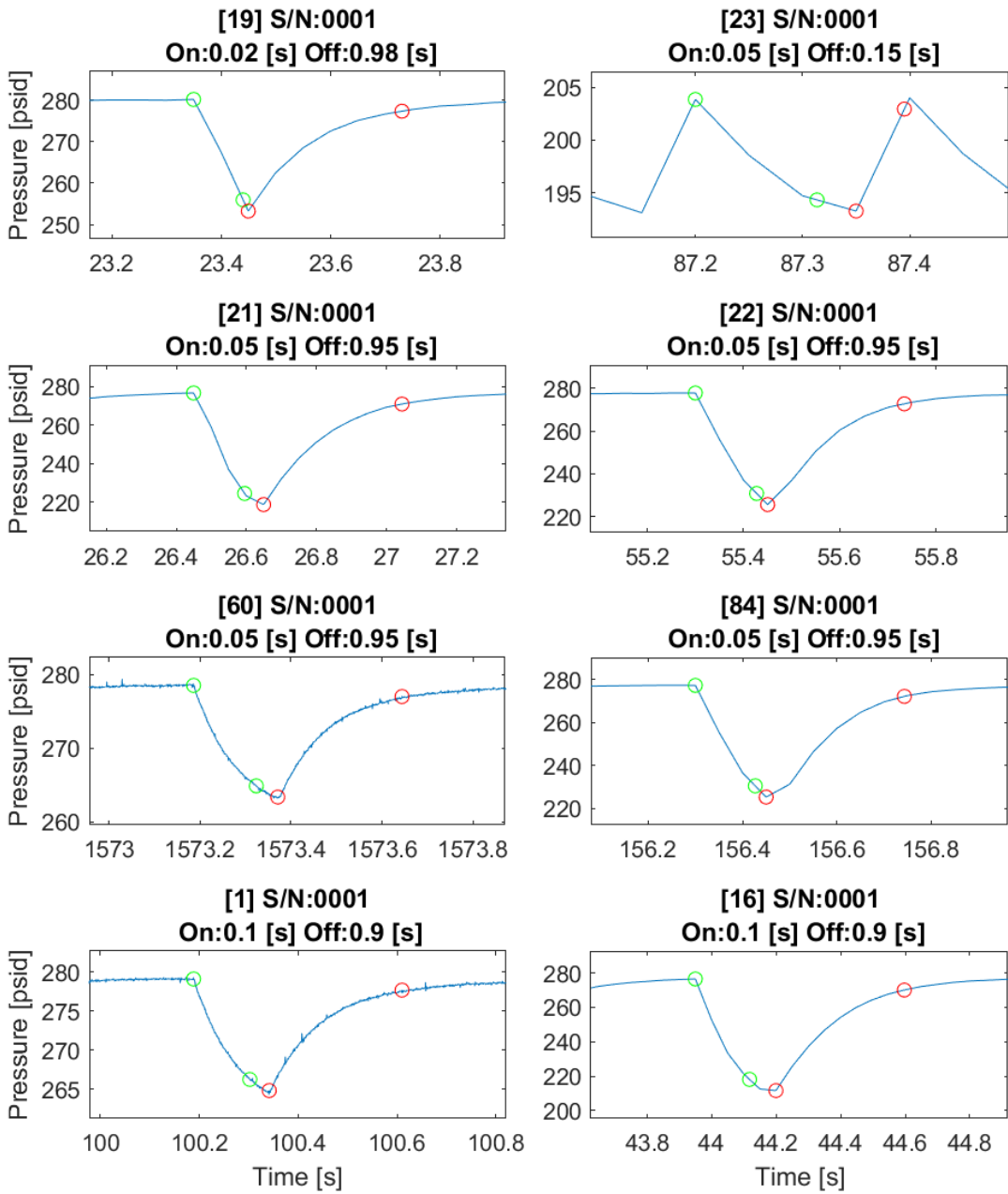

**Figure 78. Thruster valve traces of the differential pressure transducer for each data set measured 1 N thruster valves at 280 psig reservoir head pressure.**

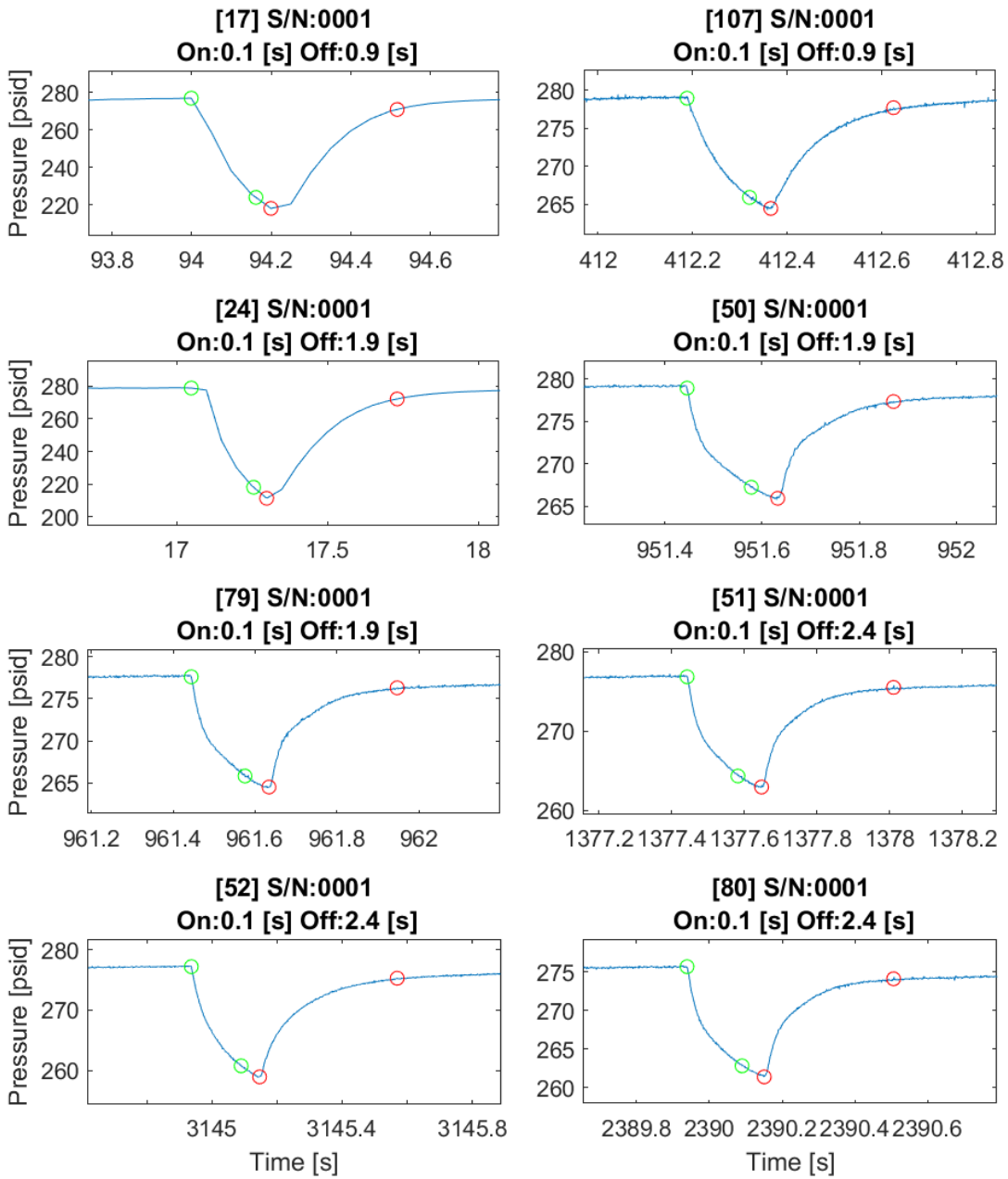

**Figure 79. Thruster valve traces of the differential pressure transducer for each data set measured 1 N thruster valves at 280 psig reservoir head pressure.**

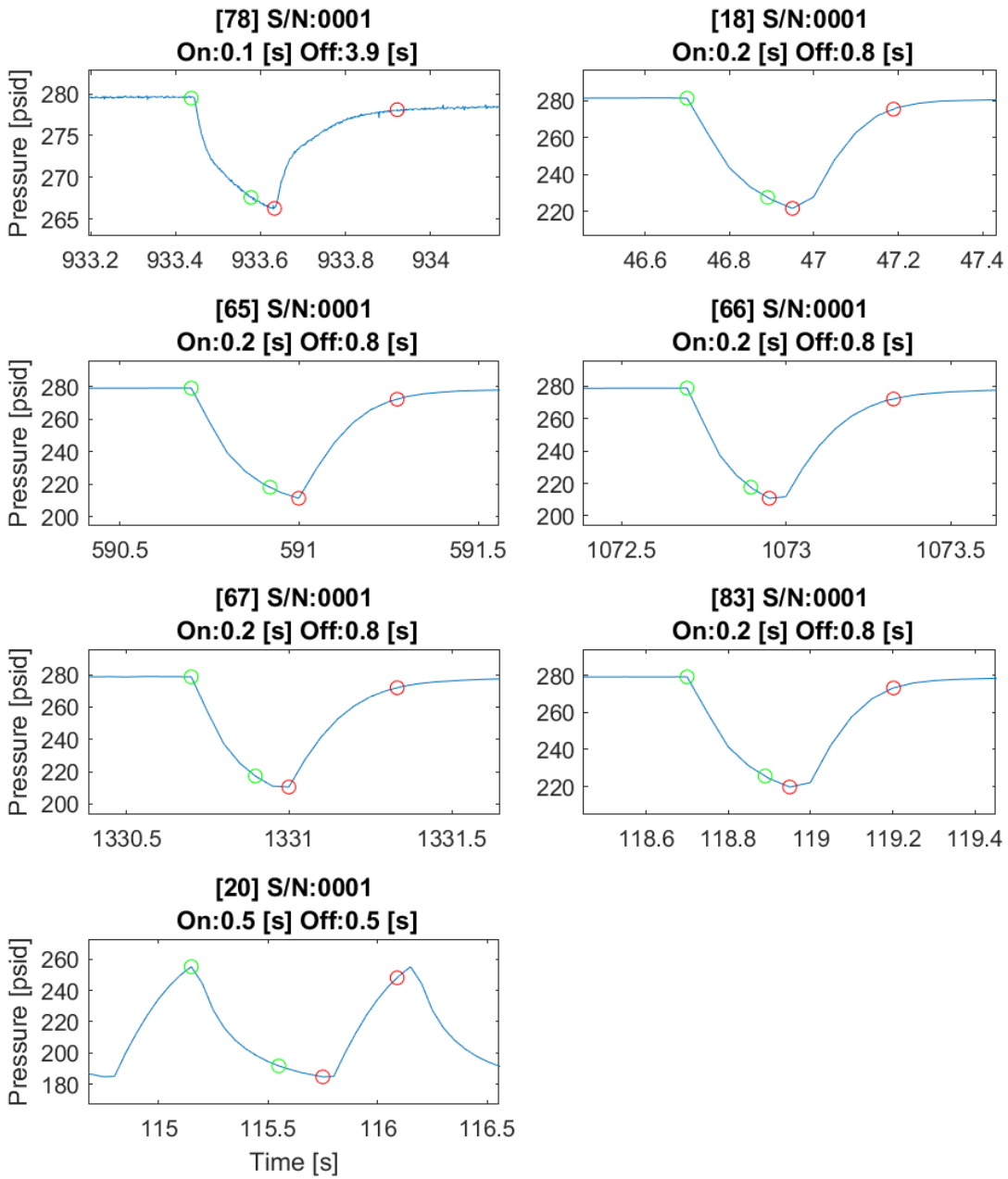

**Figure 80. Thruster valve traces of the differential pressure transducer for each data set measured 1 N thruster valves at 280 psig reservoir head pressure.**

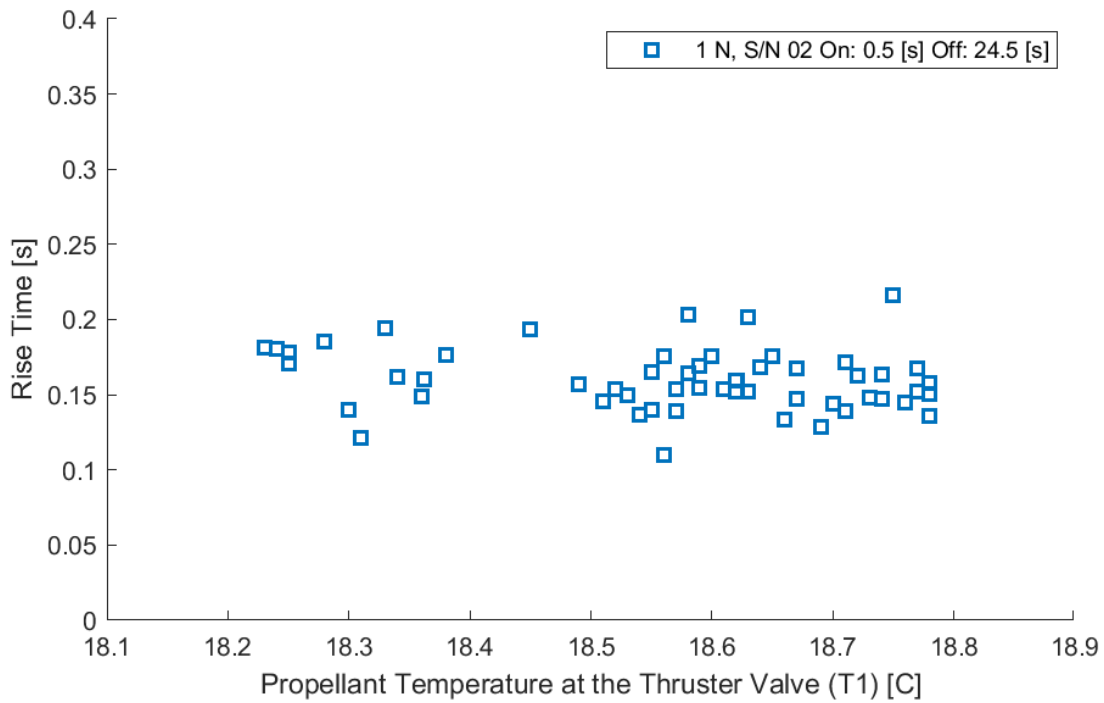

**Figure 81. Thruster valve rise time as measured by the differential pressure transducer against the propellant temperature measured at T1 for 1 N thruster valves at 410 psig reservoir head pressure.**

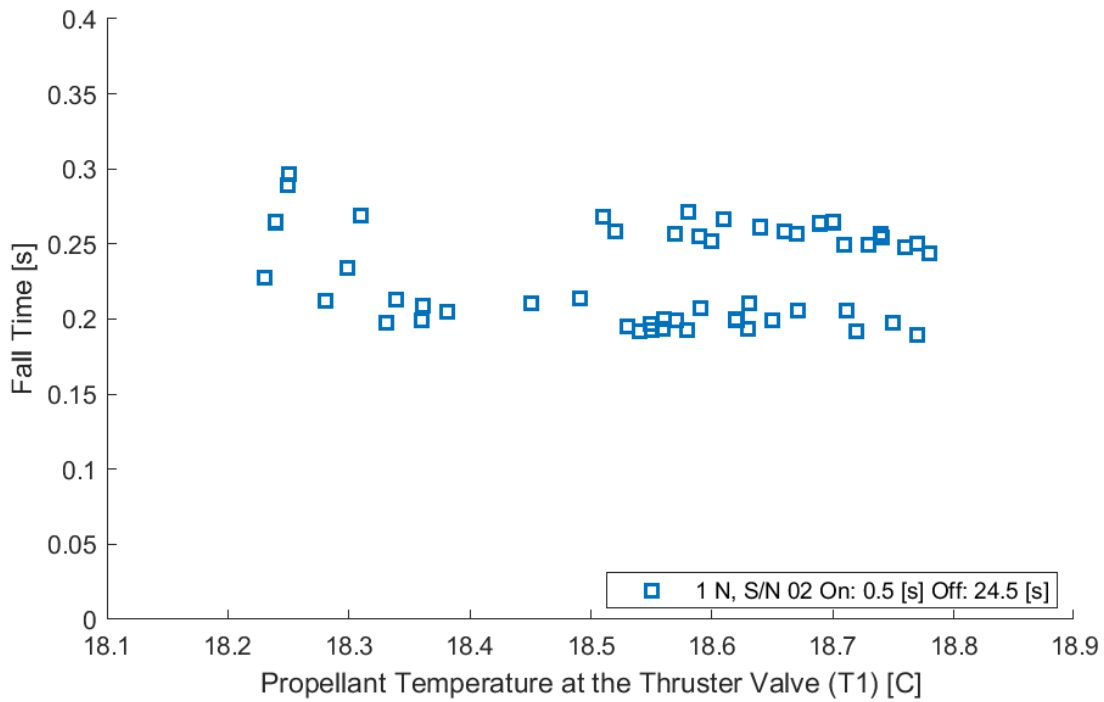

**Figure 82. Thruster valve fall time as measured by the differential pressure transducer against the propellant temperature measured at T1 for 1 N thruster valves at 410 psig reservoir head pressure.**

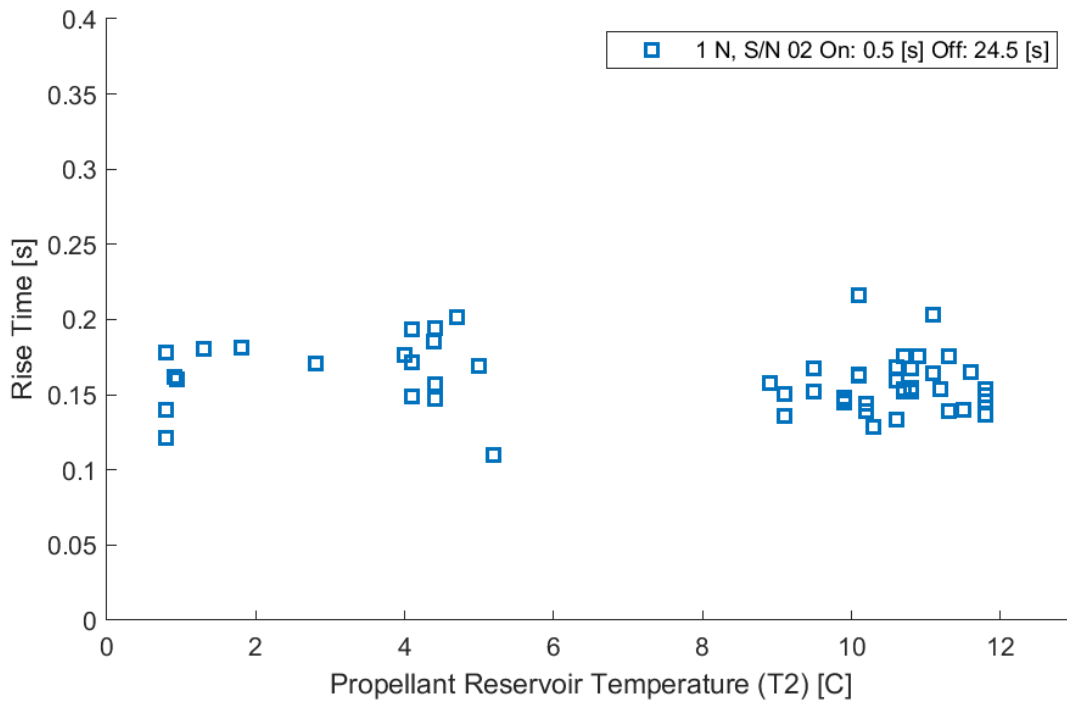

**Figure 83. Thruster valve rise time as measured by the differential pressure transducer against the propellant reservoir temperature measured at T2 for 1 N thruster valves at 410 psig reservoir head pressure.**

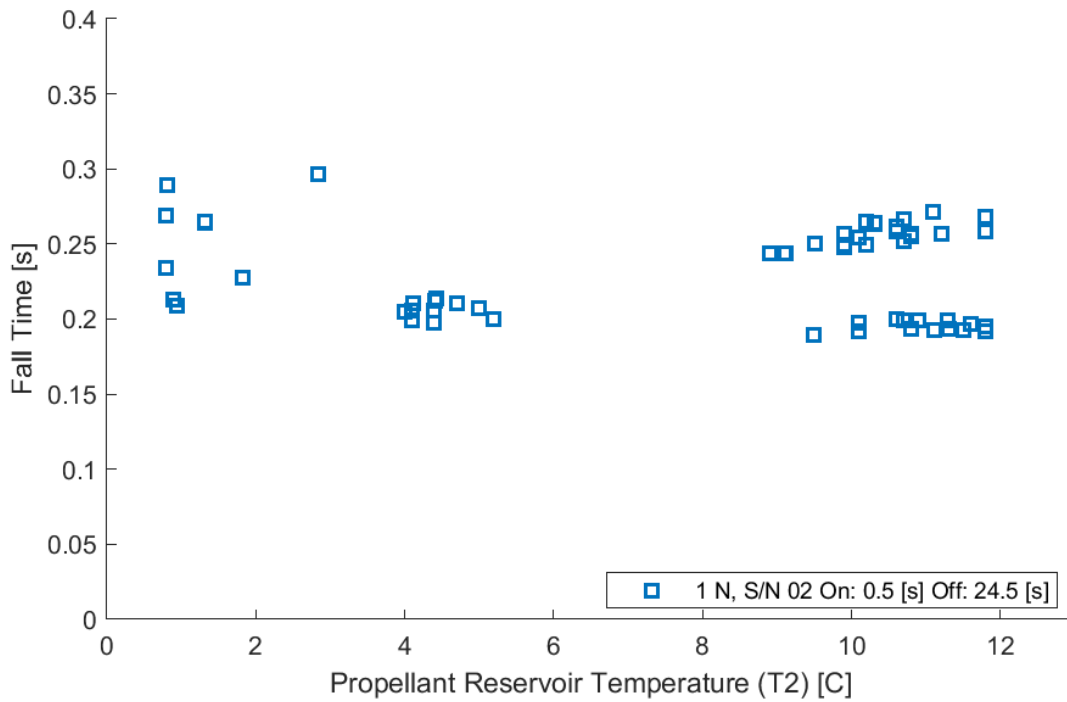

**Figure 84. Thruster valve fall time as measured by the differential pressure transducer against the propellant reservoir temperature measured at T2 for 1 N thruster valves at 410 psig reservoir head pressure.**

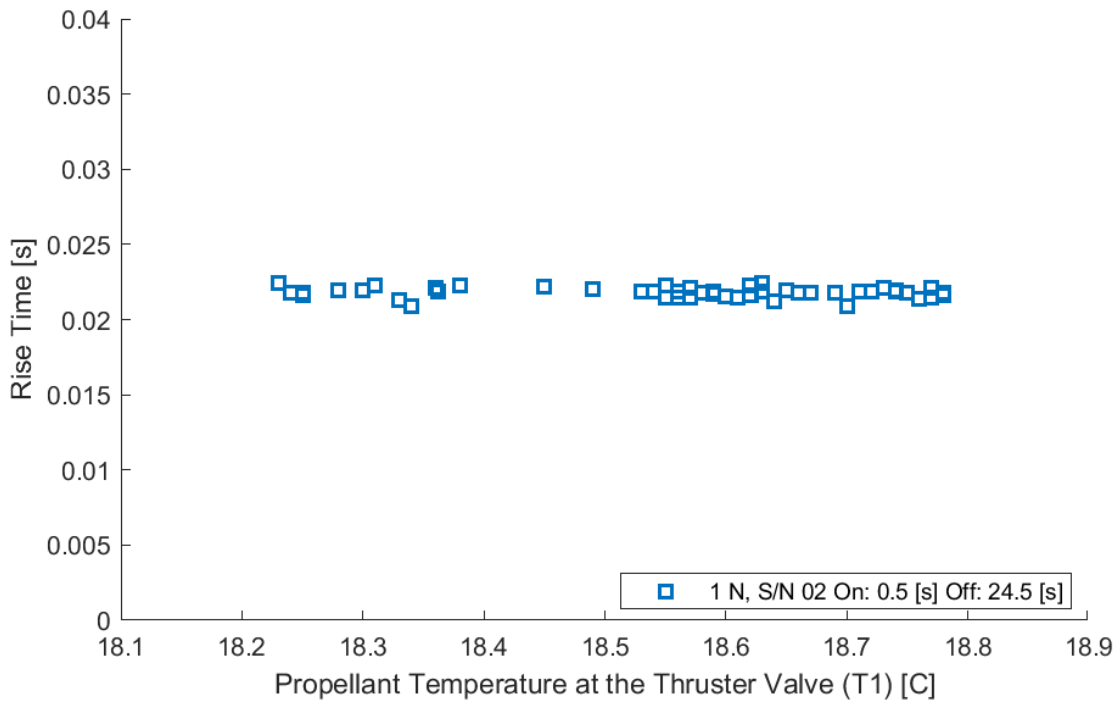

**Figure 85. Thruster valve rise time as measured by the oscilloscope against the propellant temperature measured at T1 for 1 N thruster valves at 410 psig reservoir head pressure.**

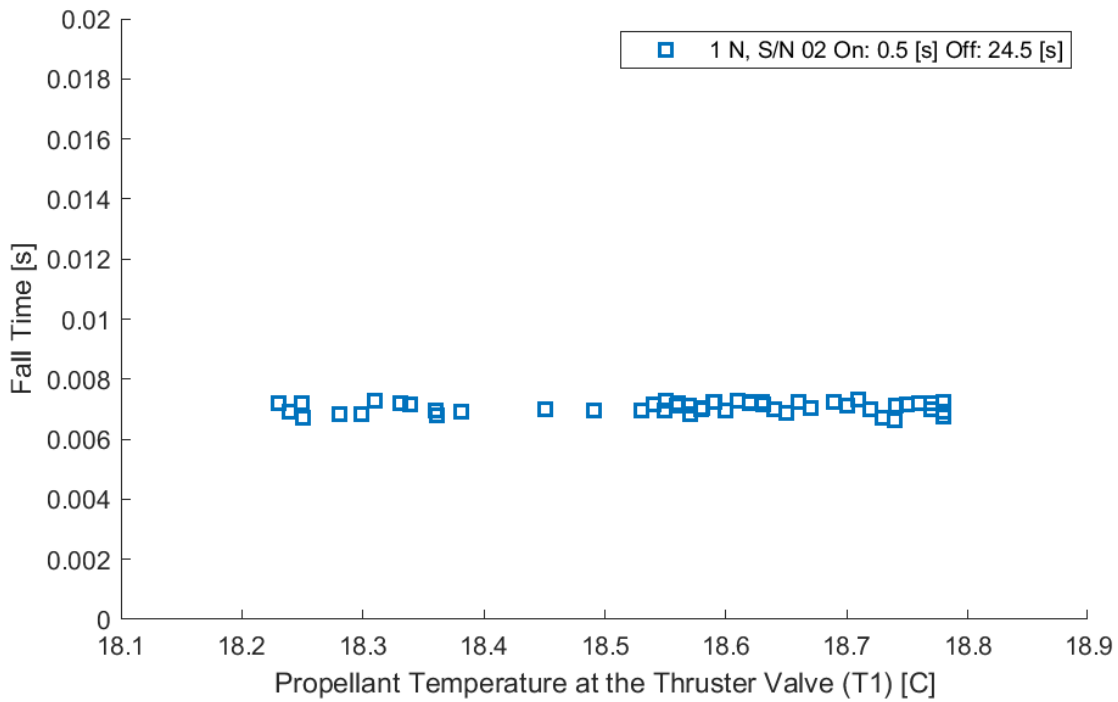

**Figure 86. Thruster valve fall time as measured by the oscilloscope against the propellant temperature measured at T1 for 1 N thruster valves at 410 psig reservoir head pressure.**

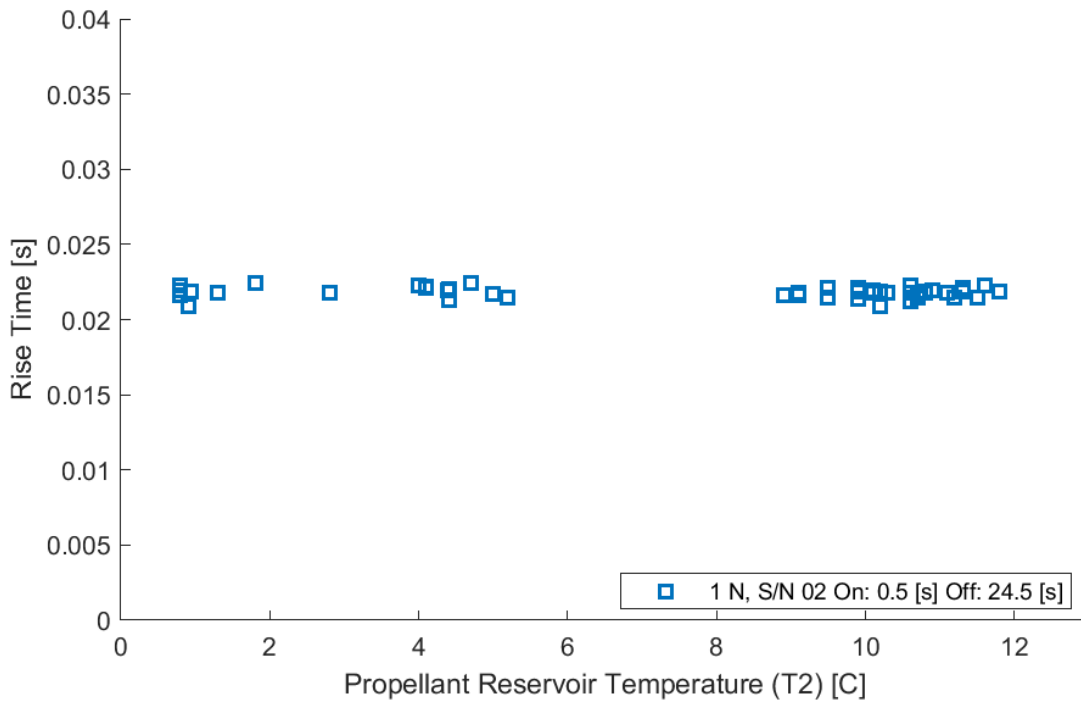

**Figure 87. Thruster valve rise time as measured by the differential pressure transducer against the commanded on time for 1 N thruster valves at 410 psig reservoir head pressure.**

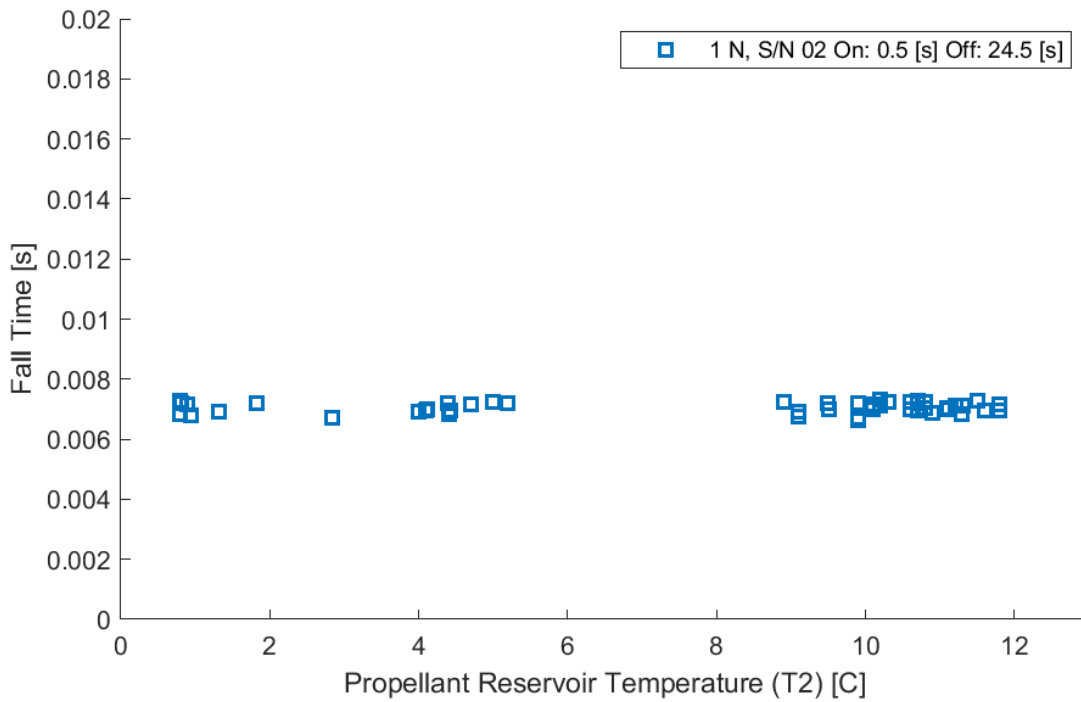

**Figure 88. Thruster valve fall time as measured by the differential pressure transducer against the off time for 1 N thruster valves at 410 psig reservoir head pressure.**

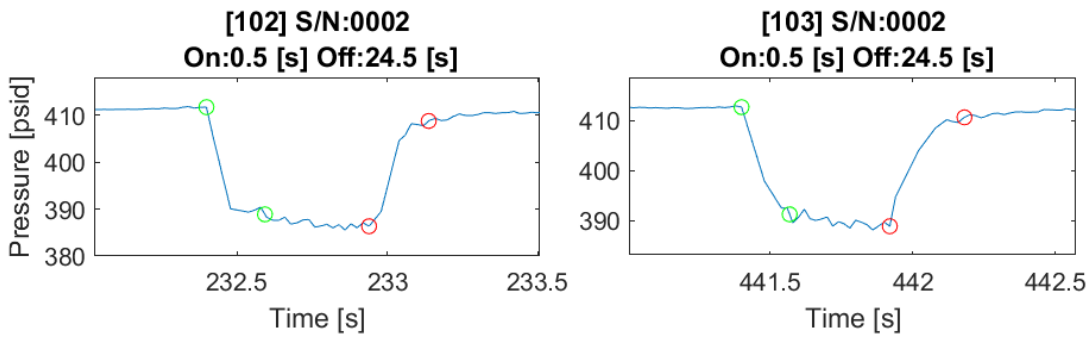

**Figure 89. Thruster valve traces of the differential pressure transducer for each data set measured 1 N thruster valves at 410 psig reservoir head pressure.**

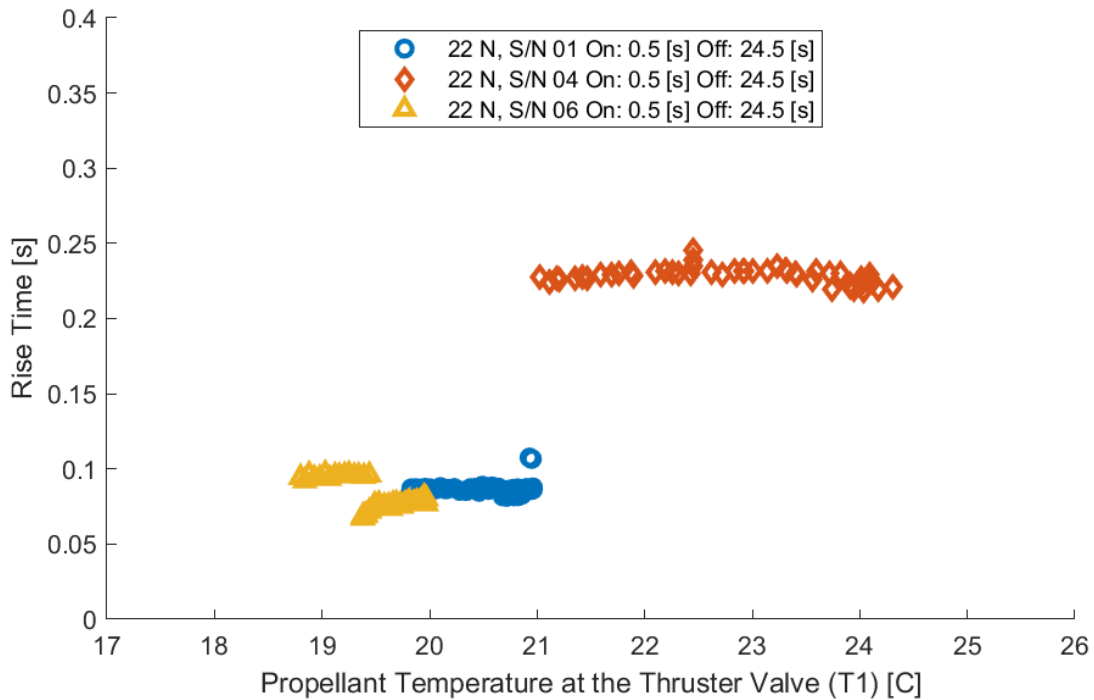

**Figure 90. Thruster valve rise time as measured by the differential pressure transducer against the propellant temperature measured at T1 for 22 N thruster valves at 125 psig reservoir head pressure.**

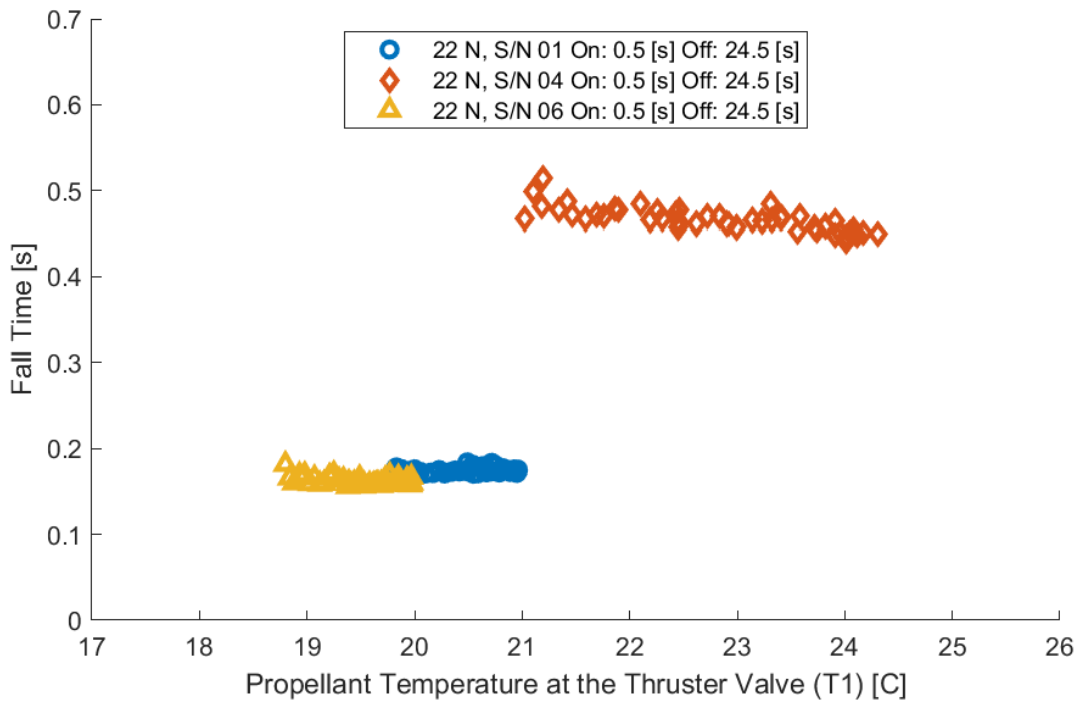

**Figure 91. Thruster valve fall time as measured by the differential pressure transducer against the propellant temperature measured at T1 for 22 N thruster valves at 125 psig reservoir head pressure.**

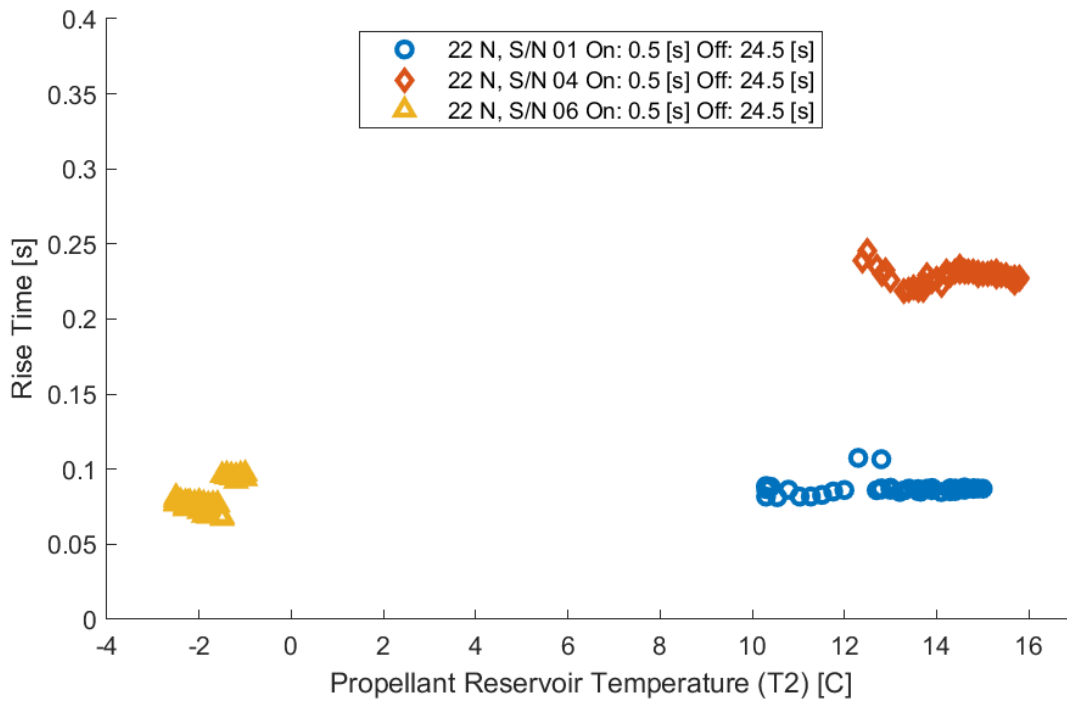

**Figure 92. Thruster valve rise time as measured by the differential pressure transducer against the propellant reservoir temperature measured at T2 for 22 N thruster valves at 125 psig reservoir head pressure.**

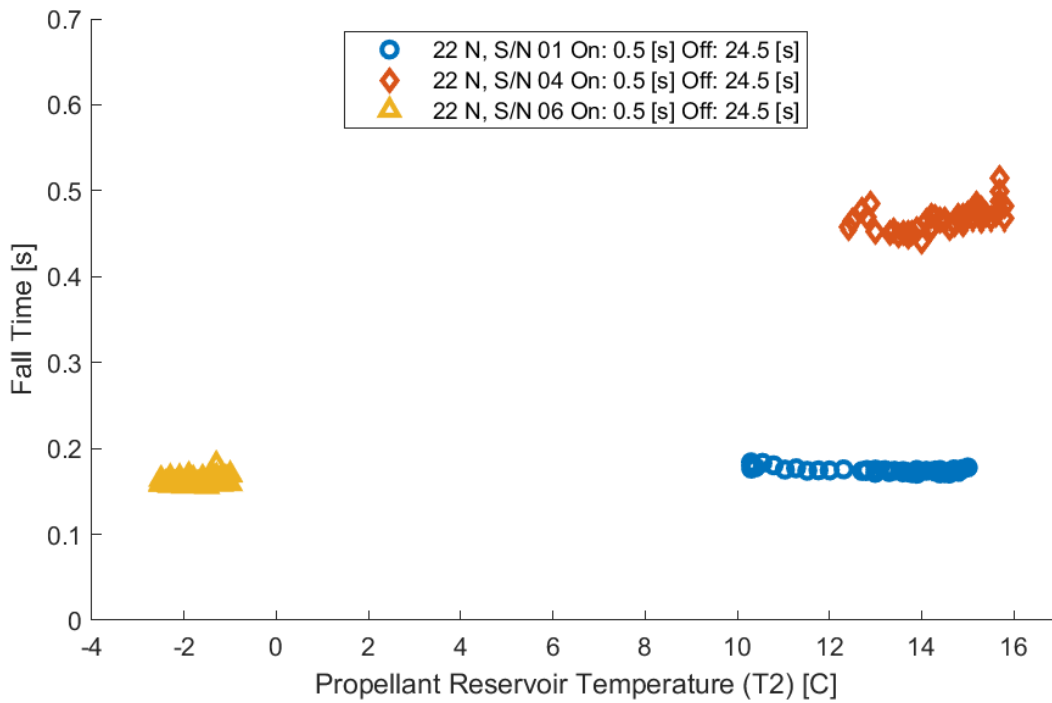

**Figure 93. Thruster valve fall time as measured by the differential pressure transducer against the propellant reservoir temperature measured at T2 for 22 N thruster valves at 125 psig reservoir head pressure.**

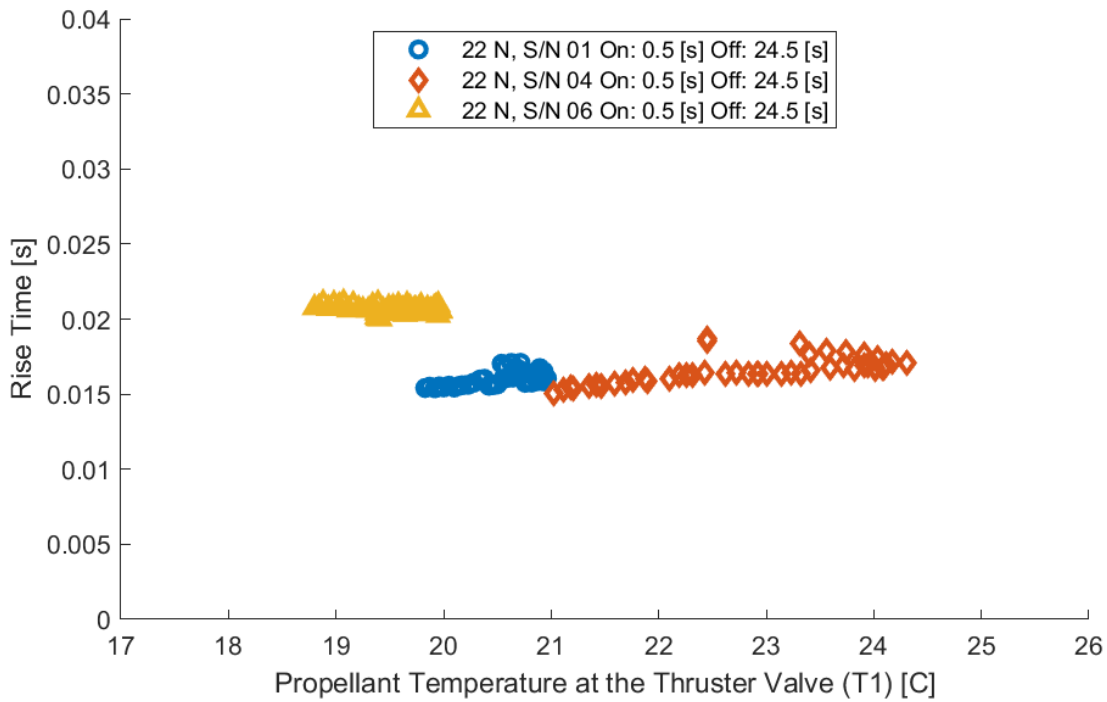

**Figure 94. Thruster valve rise time as measured by the oscilloscope against the propellant temperature measured at T1 for 22 N thruster valves at 125 psig reservoir head pressure.**

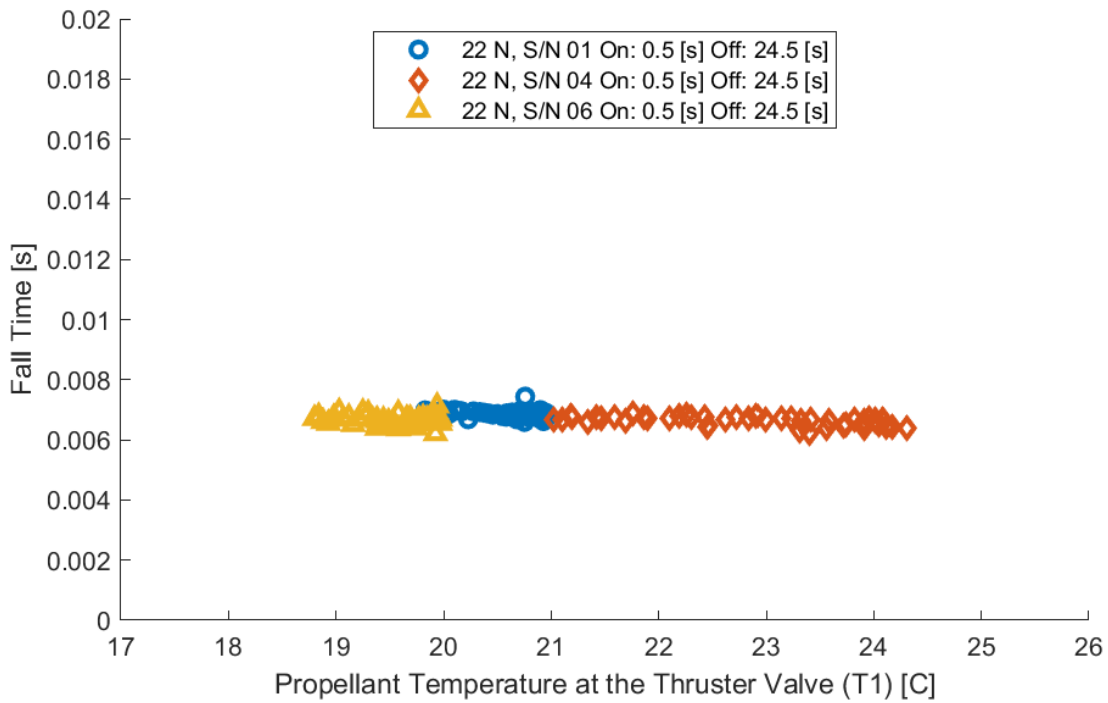

**Figure 95. Thruster valve fall time as measured by the oscilloscope against the propellant temperature measured at T1 for 22 N thruster valves at 125 psig reservoir head pressure.**

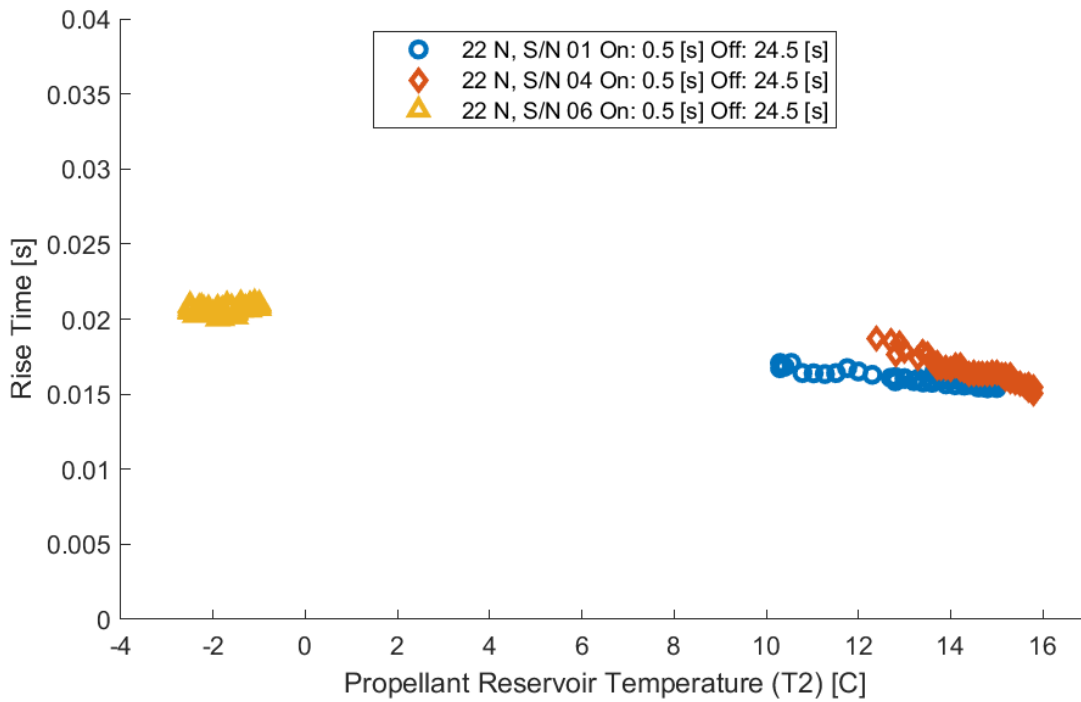

**Figure 96. Thruster valve rise time as measured by the oscilloscope against the propellant reservoir temperature measured at T2 for 22 N thruster valves at 125 psig reservoir head pressure.**

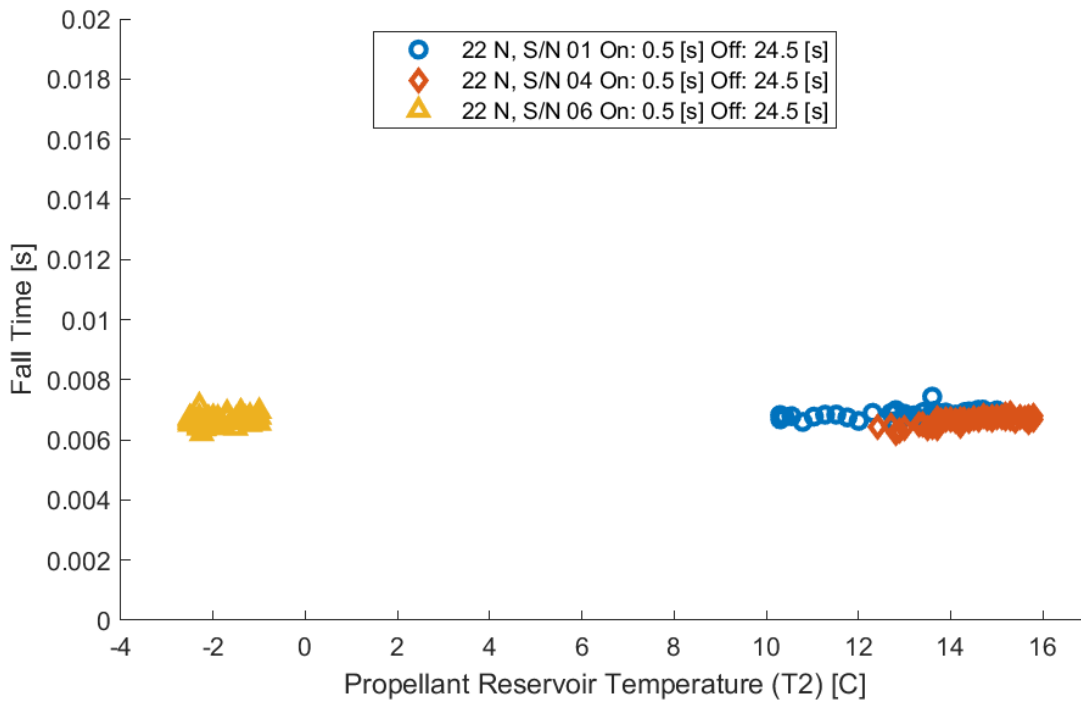

Figure 97. Thruster valve fall time as measured by the oscilloscope against the propellant reservoir temperature measured at T2 for 22 N thruster valves at 125 psig reservoir head pressure.

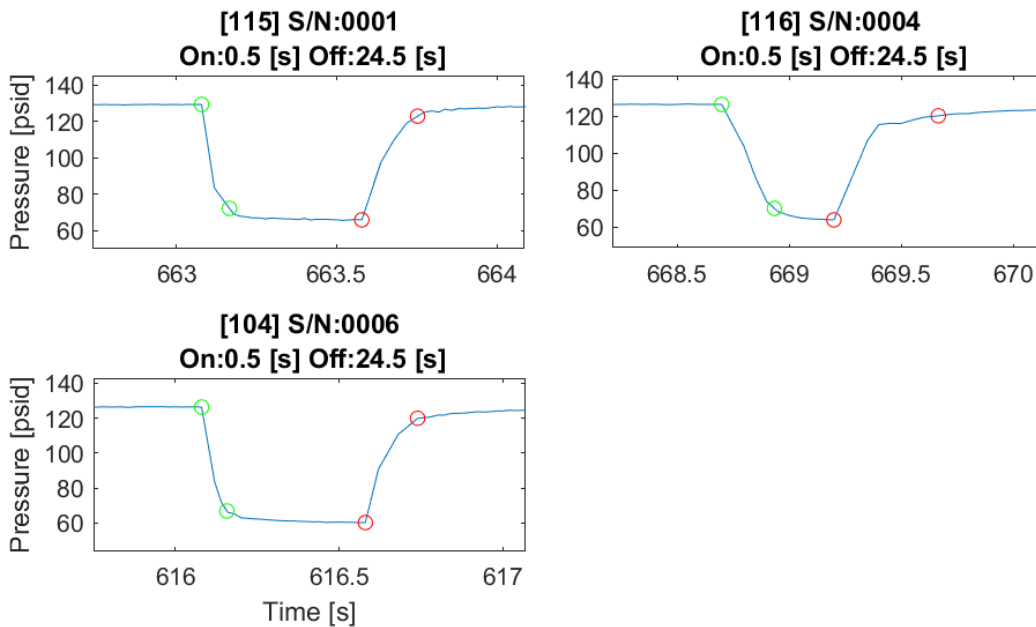
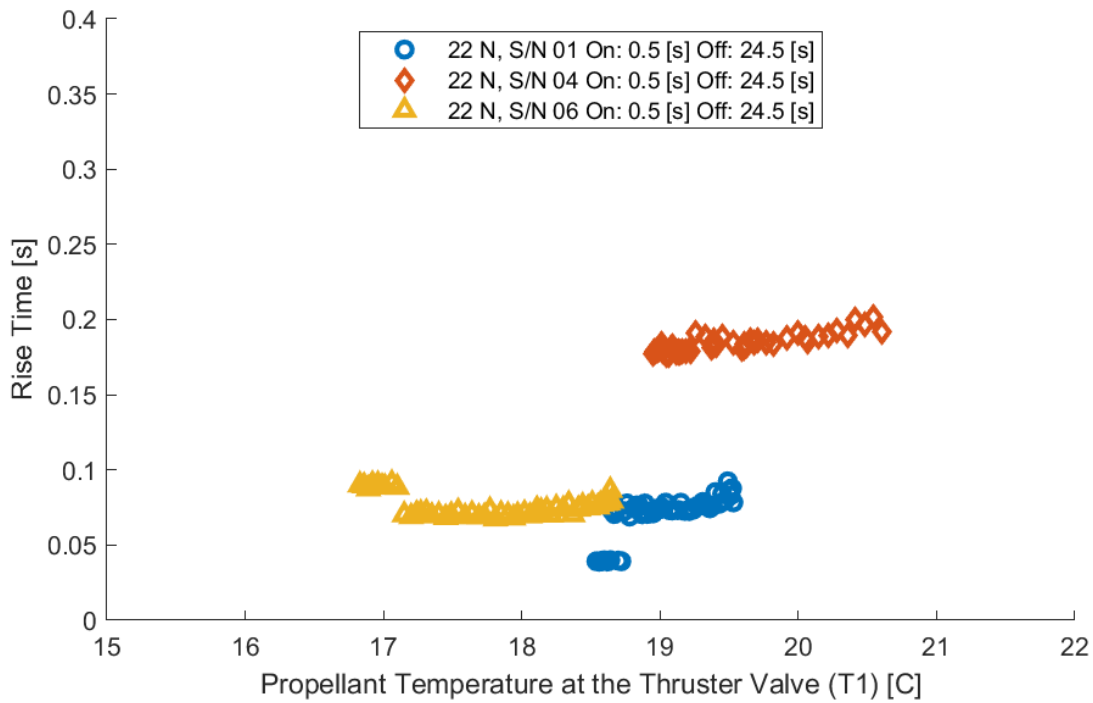
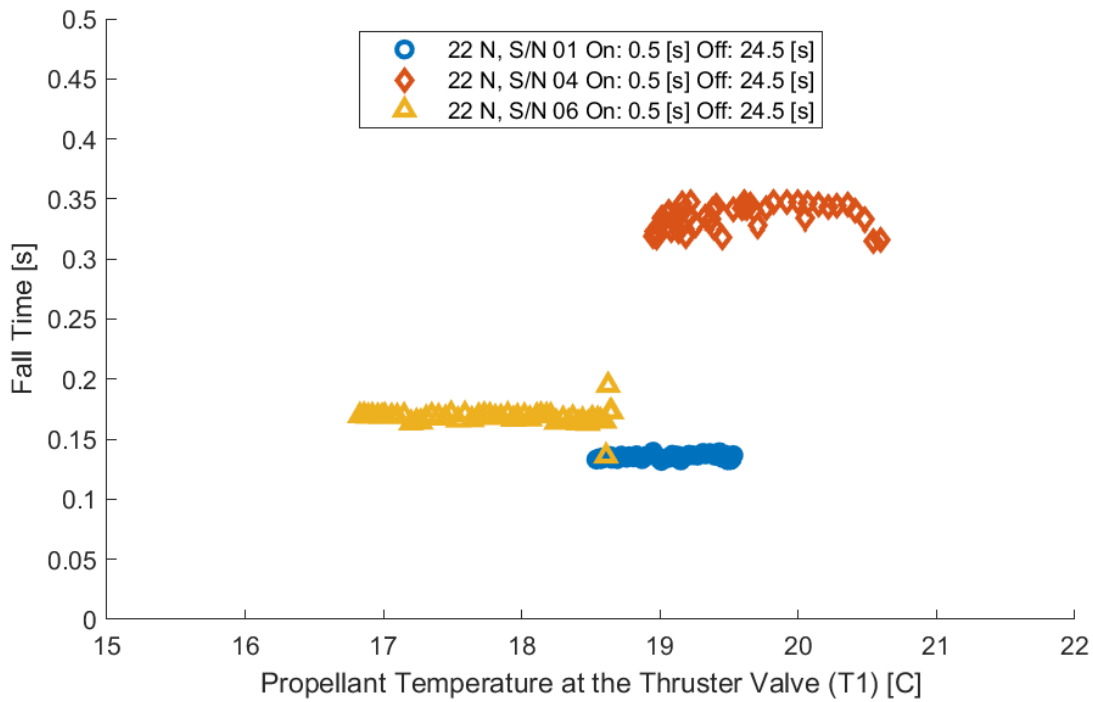

Figure 98. Thruster valve traces of the differential pressure transducer for each data set measured 22 N thruster valves at 125 psig reservoir head pressure.



**Figure 99. Thruster valve rise time as measured by the differential pressure transducer against the propellant temperature measured at T1 for 22 N thruster valves at 260 psig reservoir head pressure.**



**Figure 100. Thruster valve fall time as measured by the differential pressure transducer against the propellant temperature measured at T1 for 22 N thruster valves at 260 psig reservoir head pressure.**

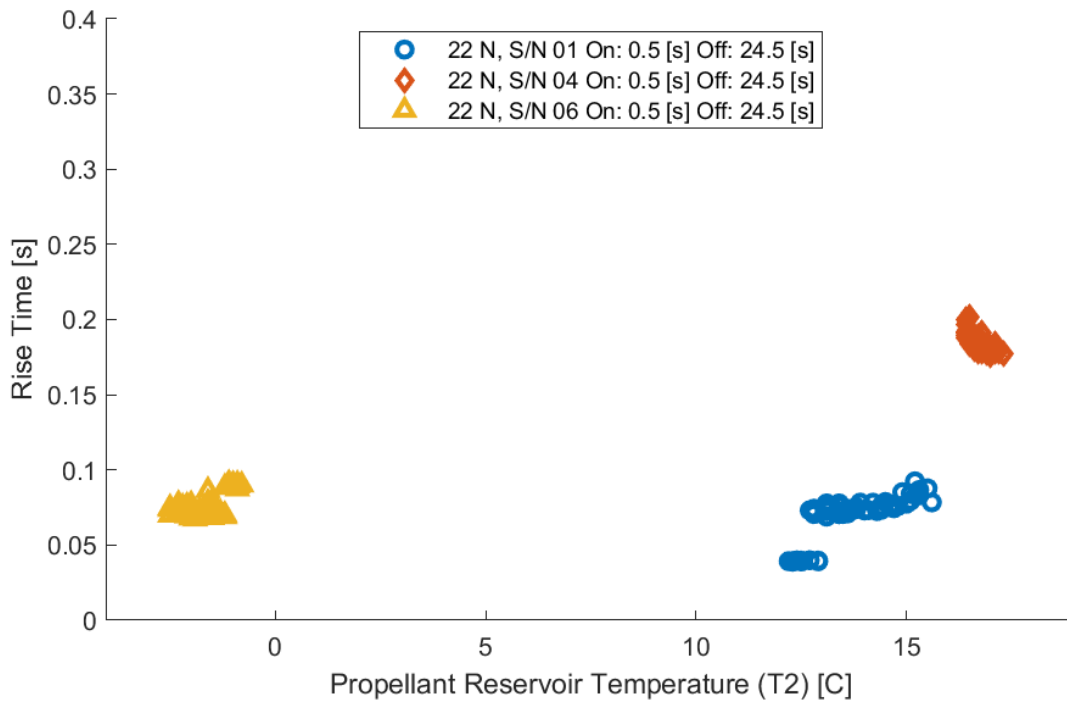

**Figure 101. Thruster valve rise time as measured by the differential pressure transducer against the propellant reservoir temperature measured at T2 for 22 N thruster valves at 260 psig reservoir head pressure.**

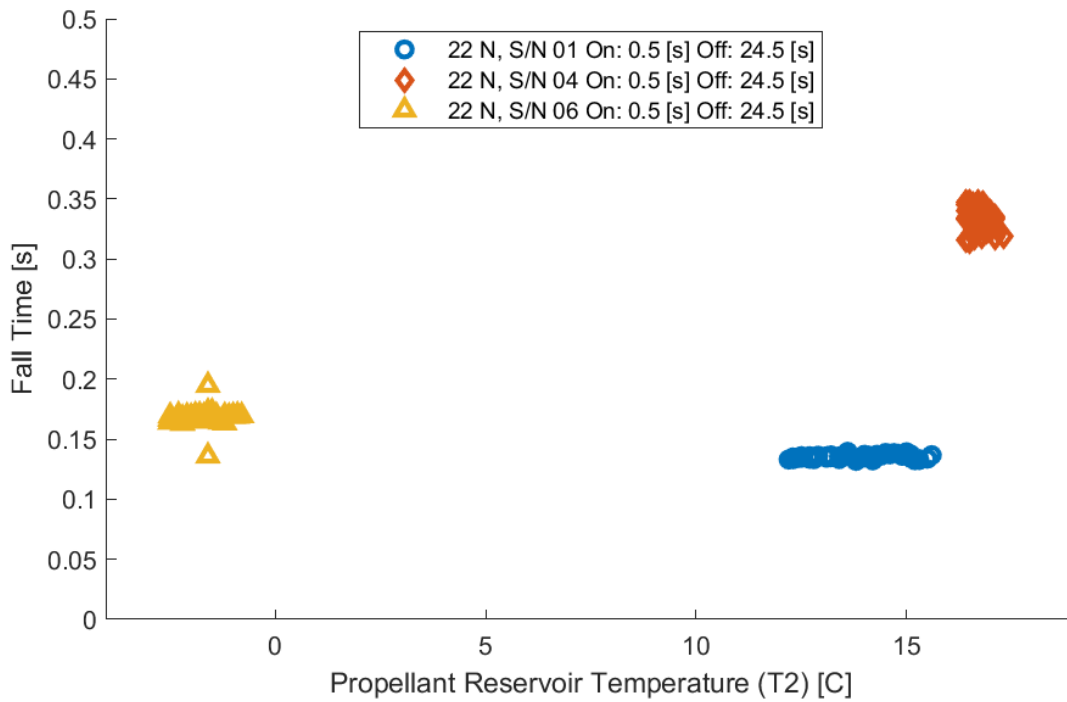

**Figure 102. Thruster valve fall time as measured by the differential pressure transducer against the propellant reservoir temperature measured at T2 for 22 N thruster valves at 260 psig reservoir head pressure.**

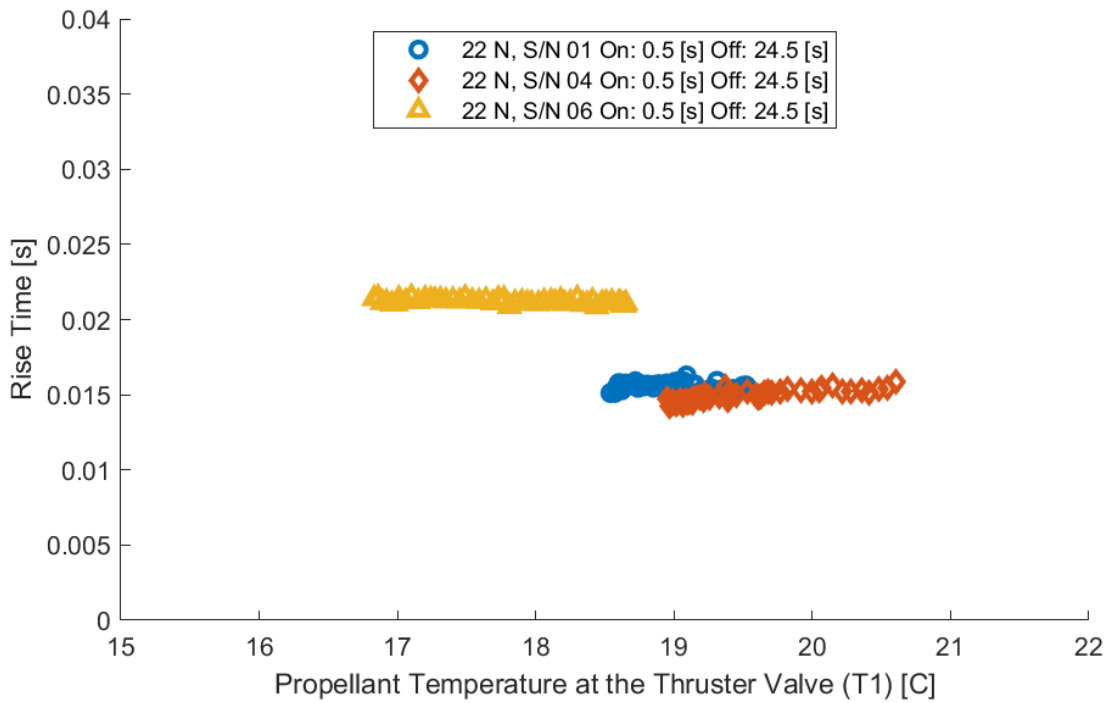

**Figure 103. Thruster valve rise time as measured by the oscilloscope against the propellant temperature measured at T1 for 22 N thruster valves at 260 psig reservoir head pressure.**

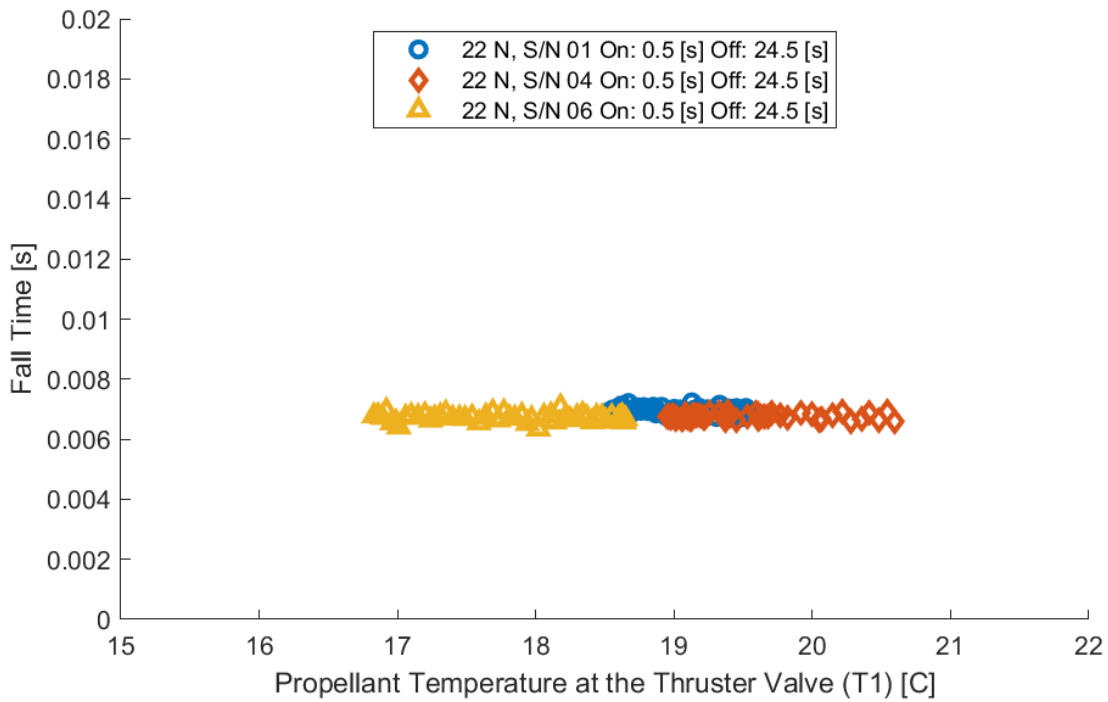

**Figure 104. Thruster valve fall time as measured by the oscilloscope against the propellant temperature measured at T1 for 22 N thruster valves at 260 psig reservoir head pressure.**

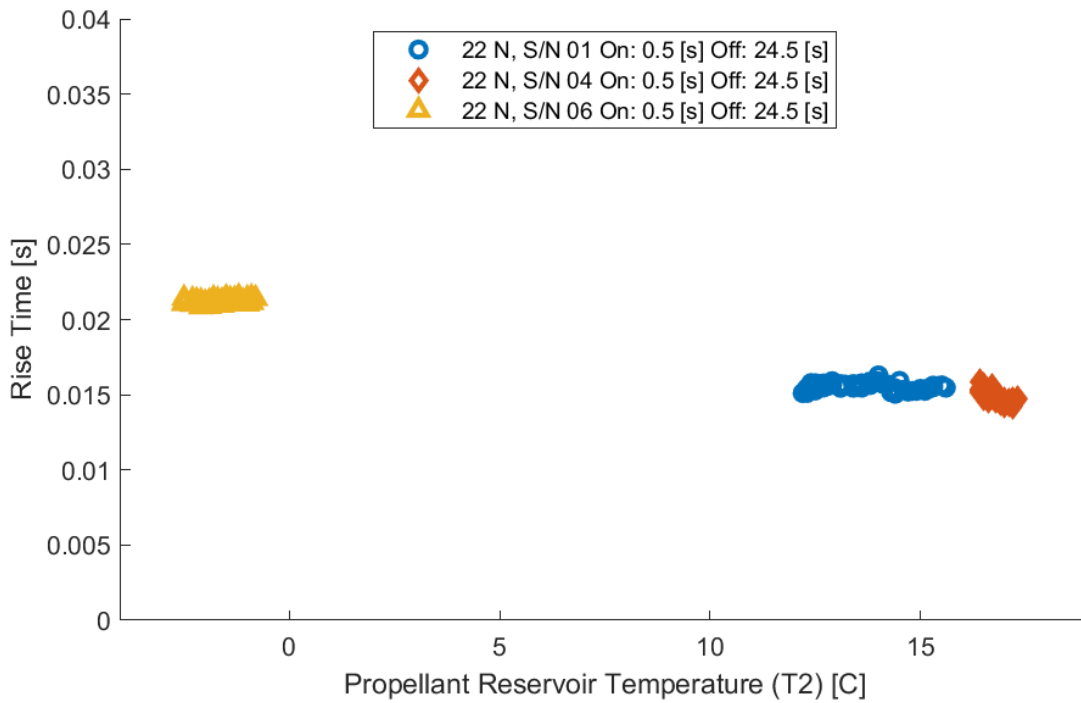

**Figure 105. Thruster valve rise time as measured by the oscilloscope against the propellant reservoir temperature measured at T2 for 22 N thruster valves at 260 psig reservoir head pressure.**

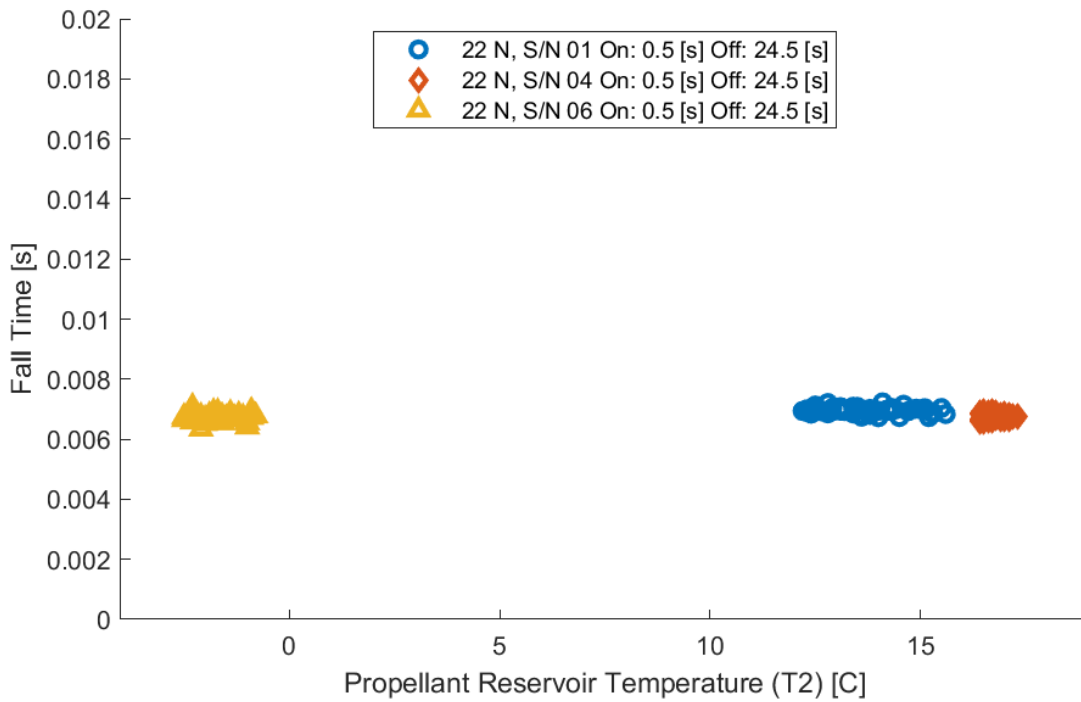

**Figure 106. Thruster valve fall time as measured by the oscilloscope against the propellant reservoir temperature measured at T2 for 22 N thruster valves at 260 psig reservoir head pressure.**

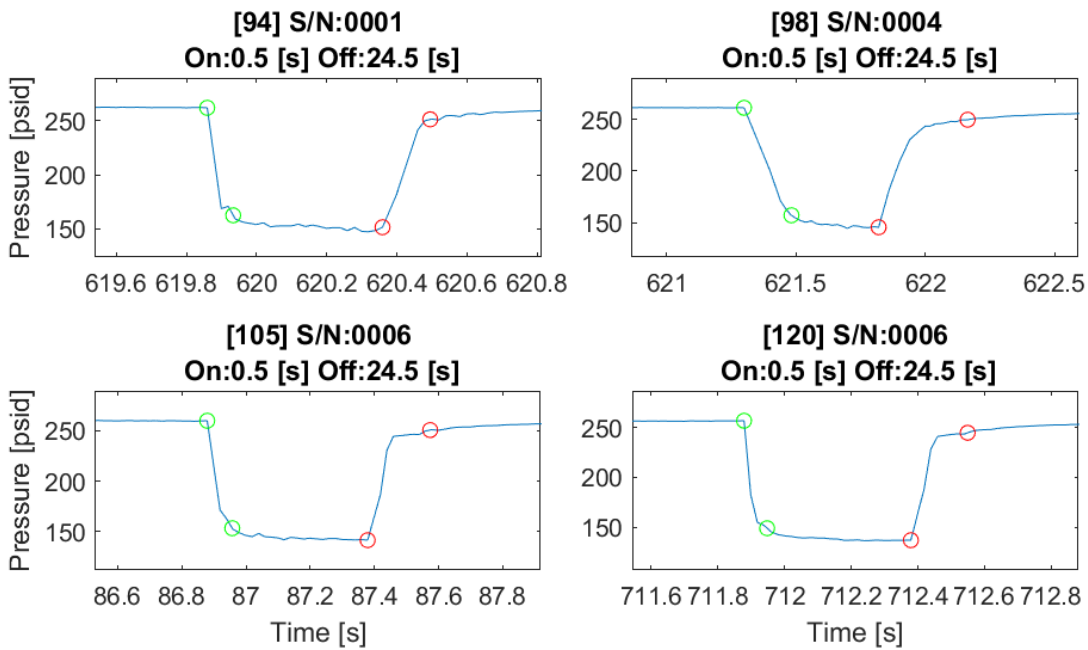

Figure 107. Thruster valve traces of the differential pressure transducer for each data set measured 22 N thruster valves at 260 psig reservoir head pressure.

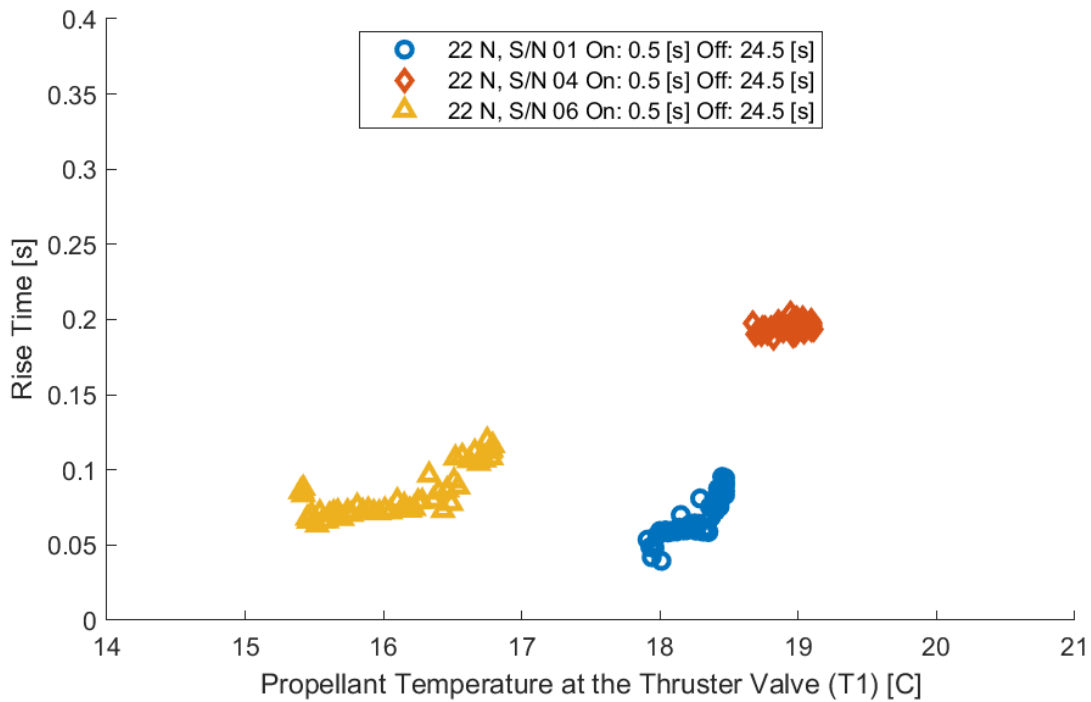
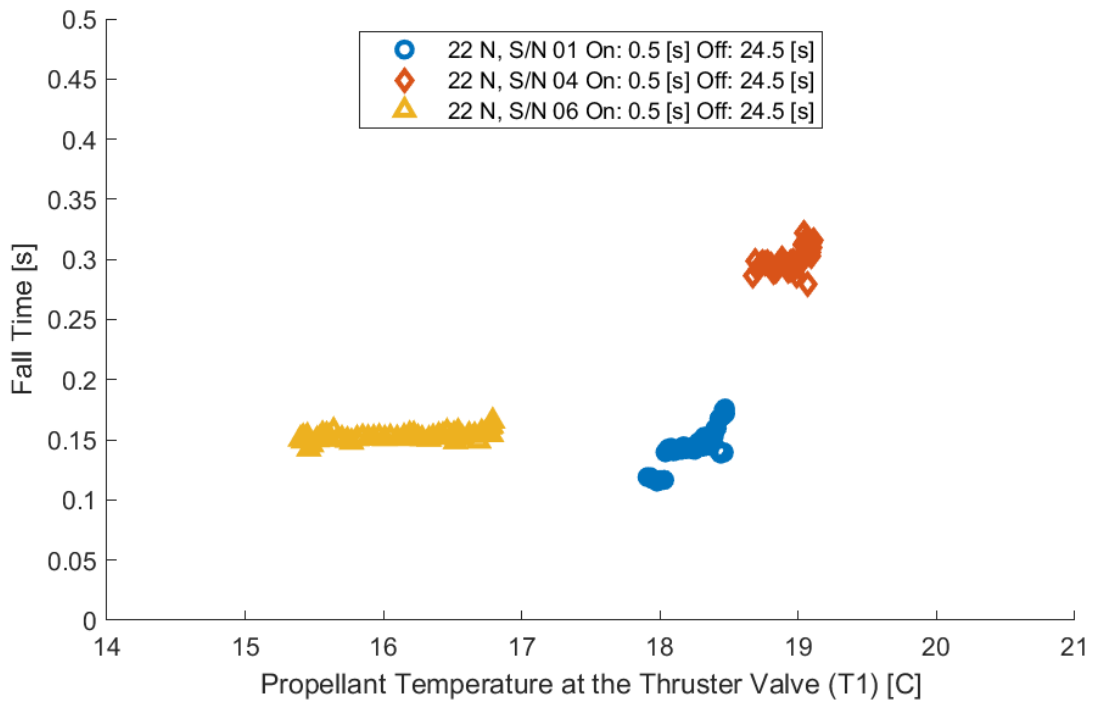
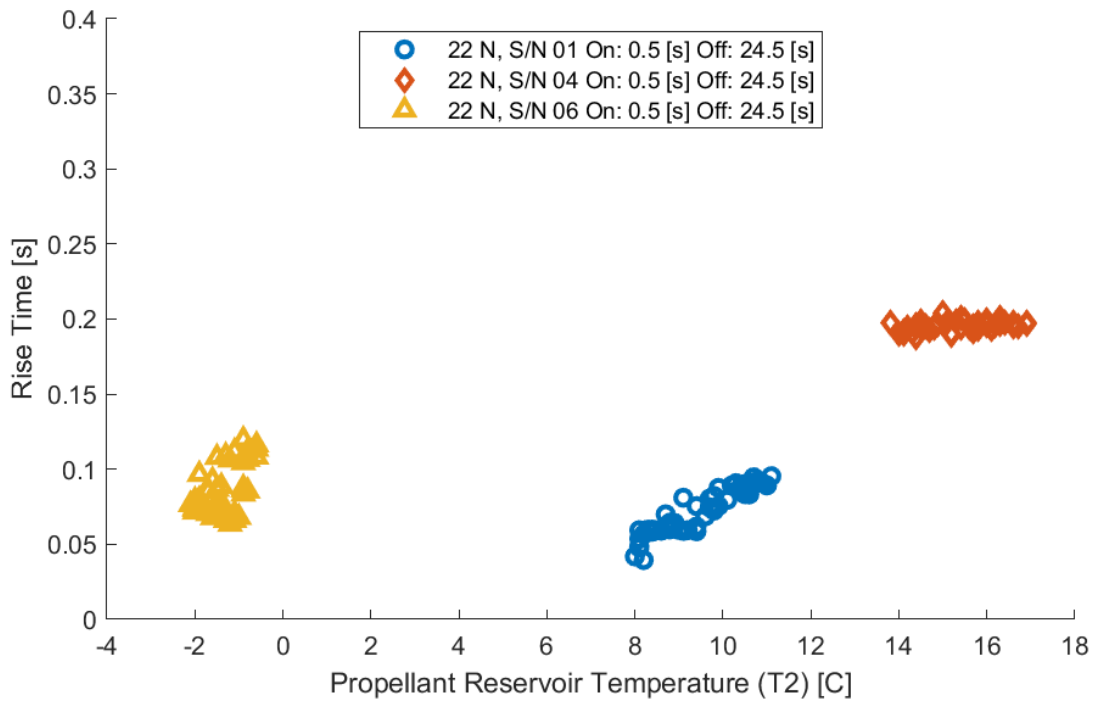

Figure 108. Thruster valve rise time as measured by the differential pressure transducer against the propellant temperature measured at T1 for 22 N thruster valves at 410 psig reservoir head pressure.



**Figure 109. Thruster valve fall time as measured by the differential pressure transducer against the propellant temperature measured at T1 for 22 N thruster valves at 410 psig reservoir head pressure.**



**Figure 110. Thruster valve rise time as measured by the differential pressure transducer against the propellant reservoir temperature measured at T2 for 22 N thruster valves at 410 psig reservoir head pressure.**

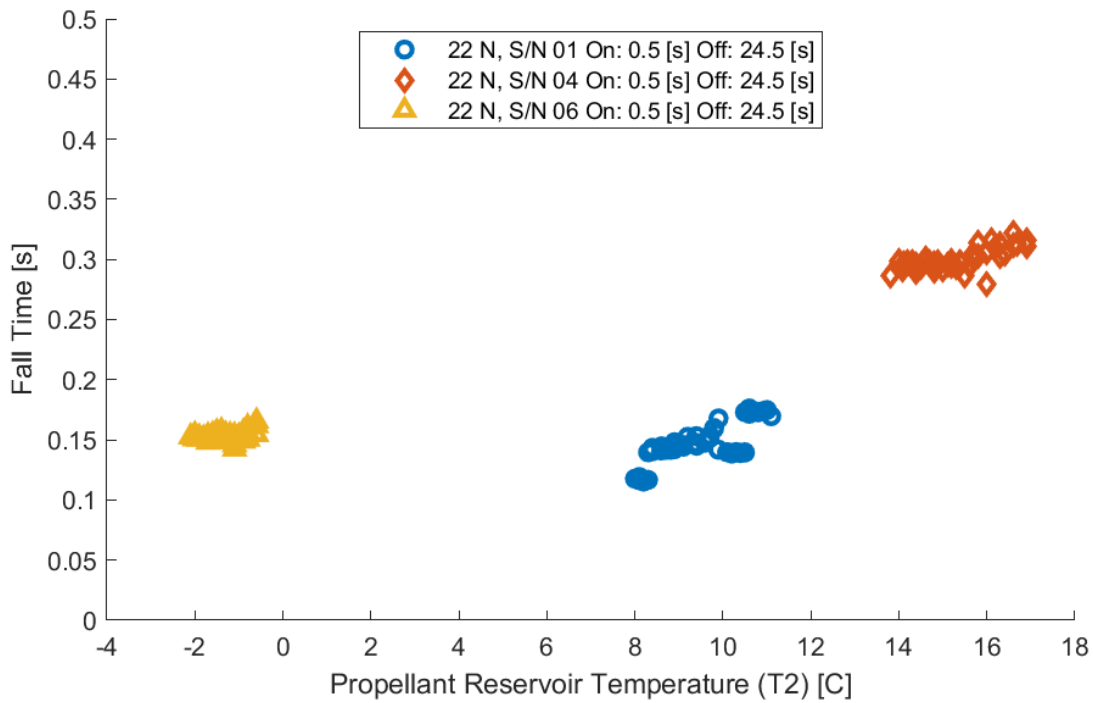

**Figure 111. Thruster valve fall time as measured by the differential pressure transducer against the propellant reservoir temperature measured at T2 for 22 N thruster valves at 410 psig reservoir head pressure.**

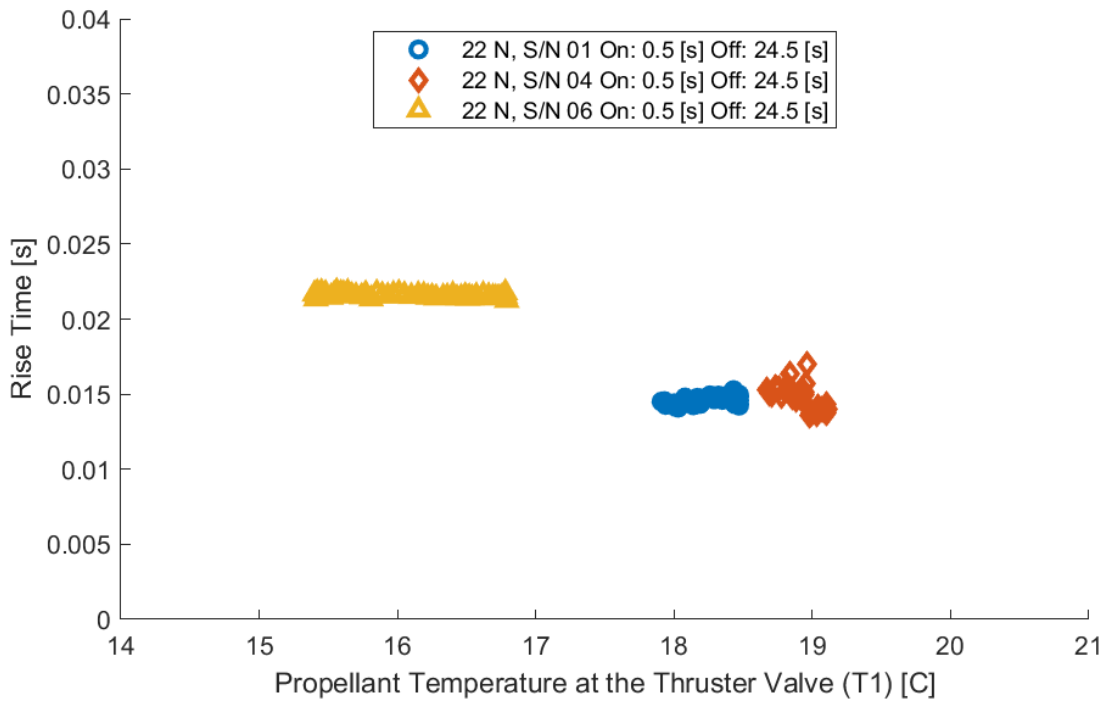

**Figure 112. Thruster valve rise time as measured by the oscilloscope against the propellant temperature measured at T1 for 22 N thruster valves at 410 psig reservoir head pressure.**

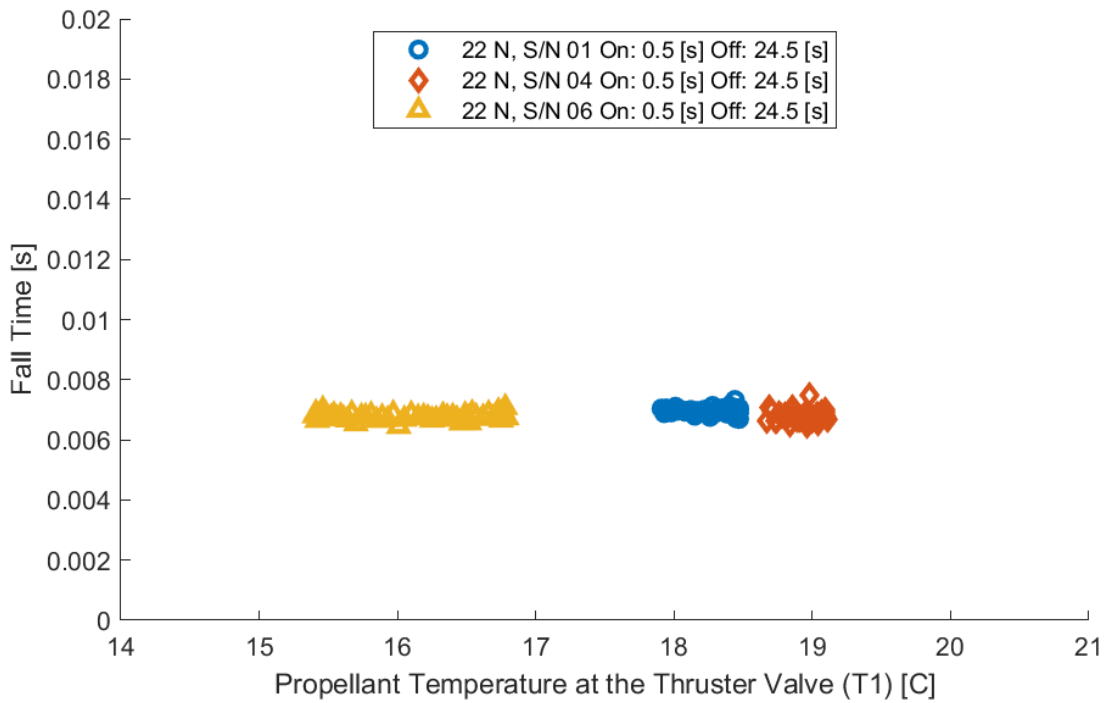

**Figure 113. Thruster valve fall time as measured by the oscilloscope against the propellant temperature measured at T1 for 22 N thruster valves at 410 psig reservoir head pressure.**

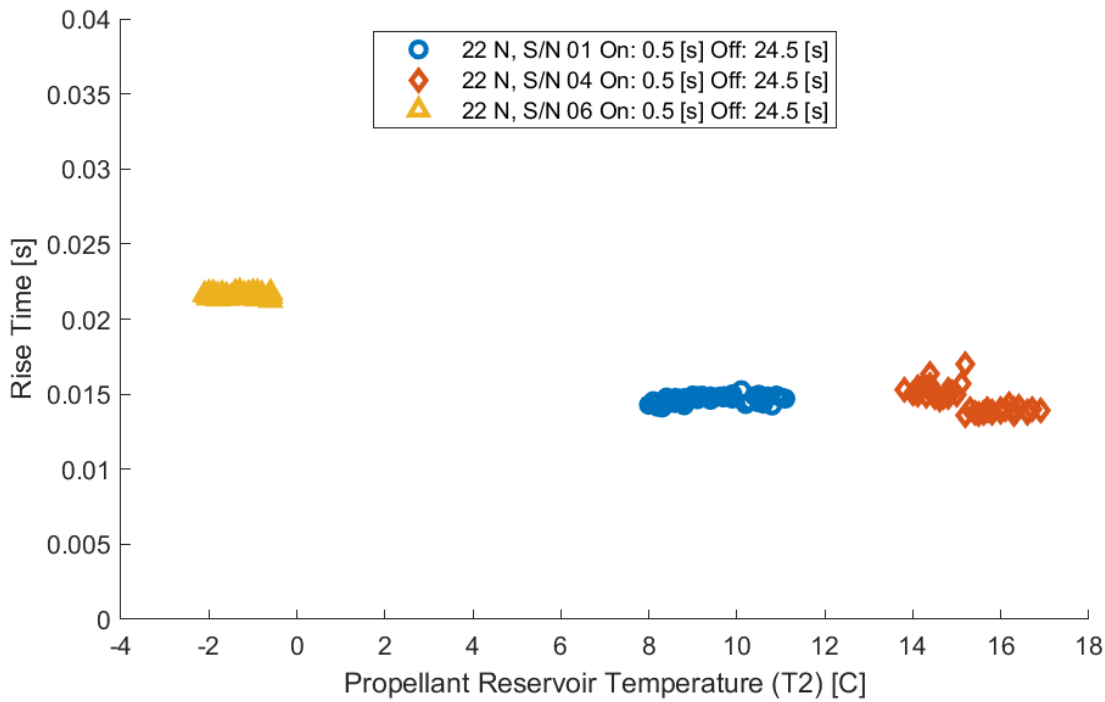

**Figure 114. Thruster valve rise time as measured by the oscilloscope against the propellant reservoir temperature measured at T2 for 22 N thruster valves at 410 psig reservoir head pressure.**

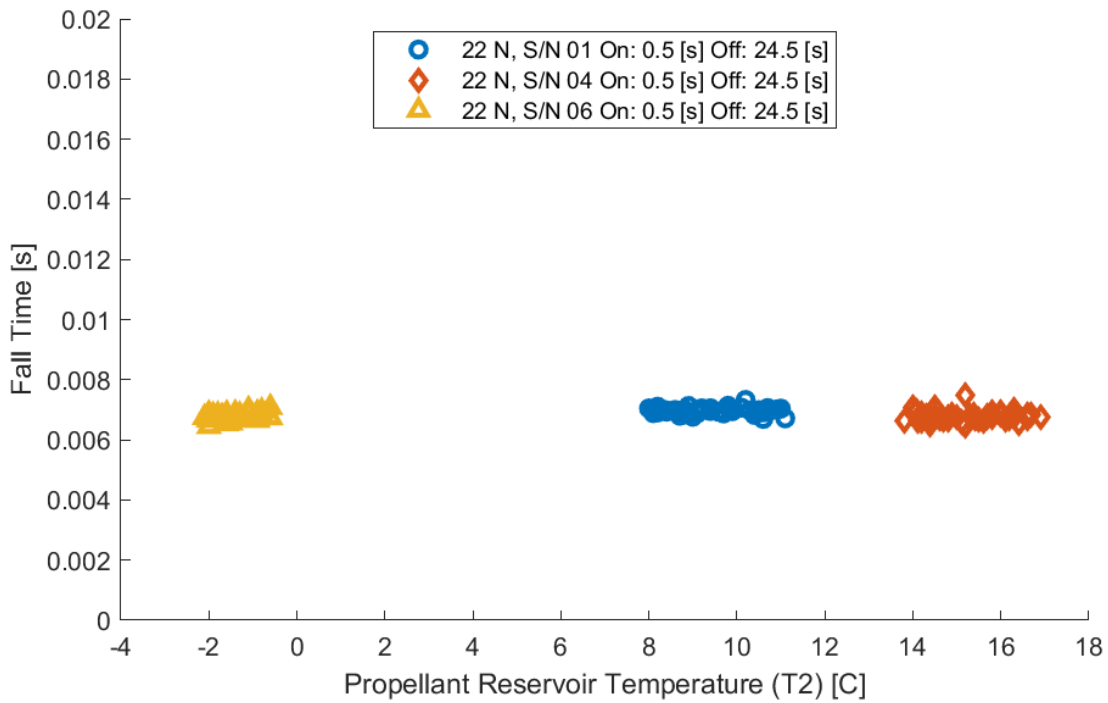

**Figure 115. Thruster valve fall time as measured by the oscilloscope against the propellant reservoir temperature measured at T2 for 22 N thruster valves at 410 psig reservoir head pressure.**

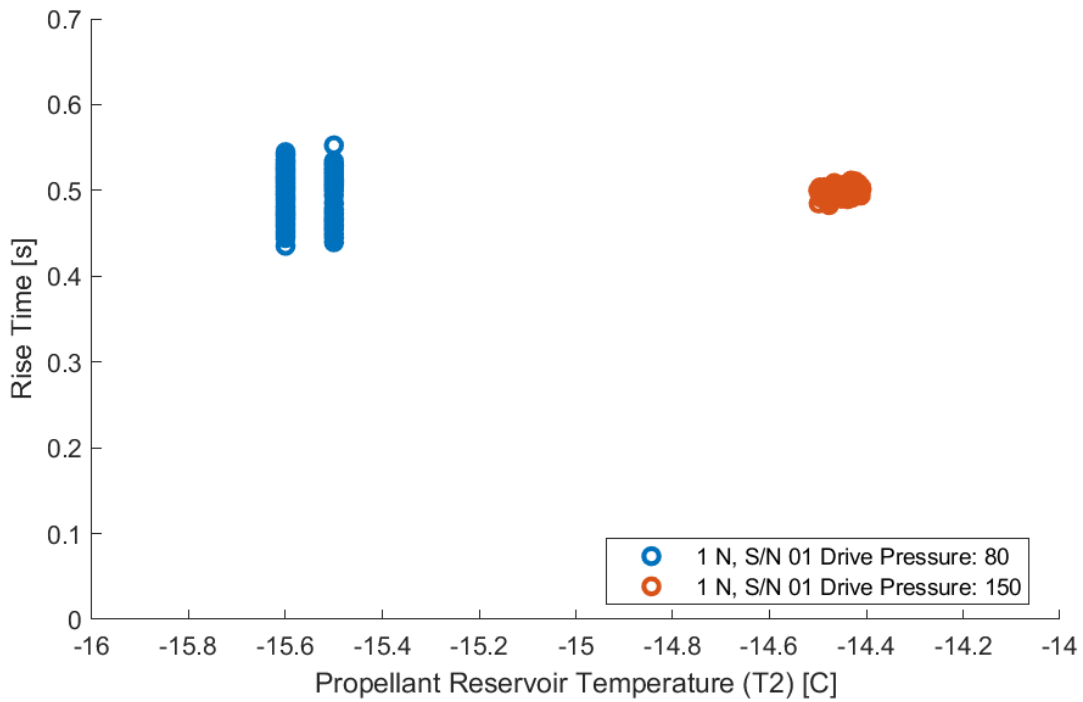

**Figure 116. Thruster valve rise time as measured by the differential pressure transducer against the reservoir temperature T2 for all reservoir pressures for on times of 0.5 s and off times of 0.5 s.**

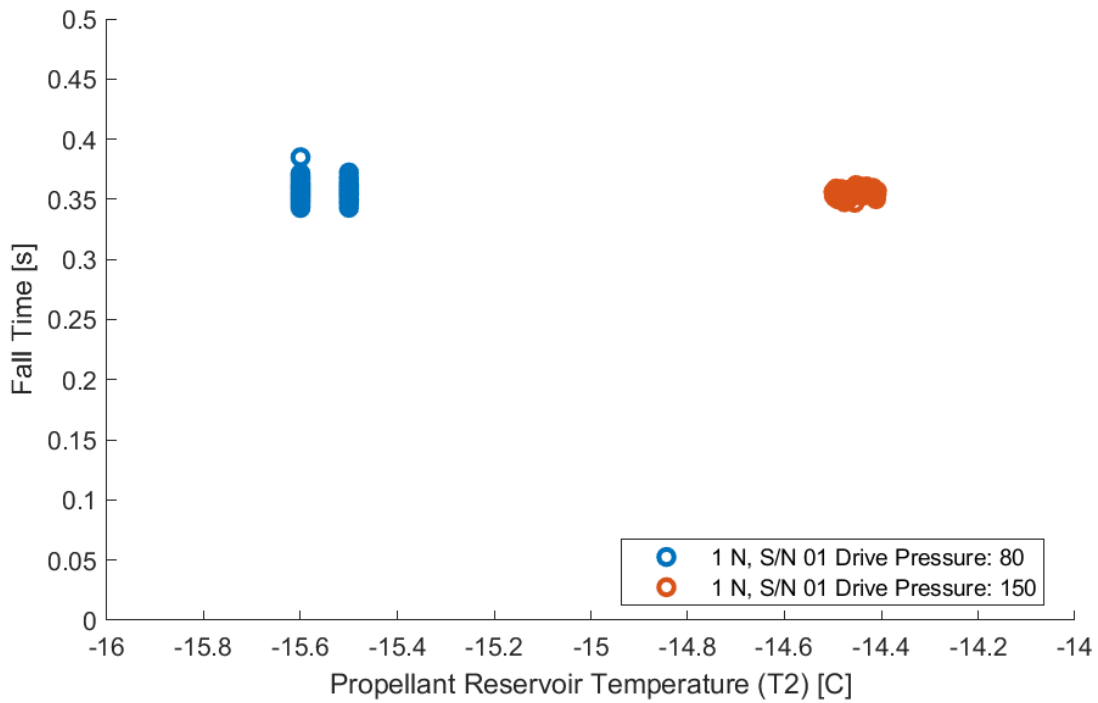

**Figure 117. Thruster valve fall time as measured by the differential pressure transducer against the propellant temperature T2 for all reservoir pressures for on times of 0.5 s and off times of 0.5 s.**

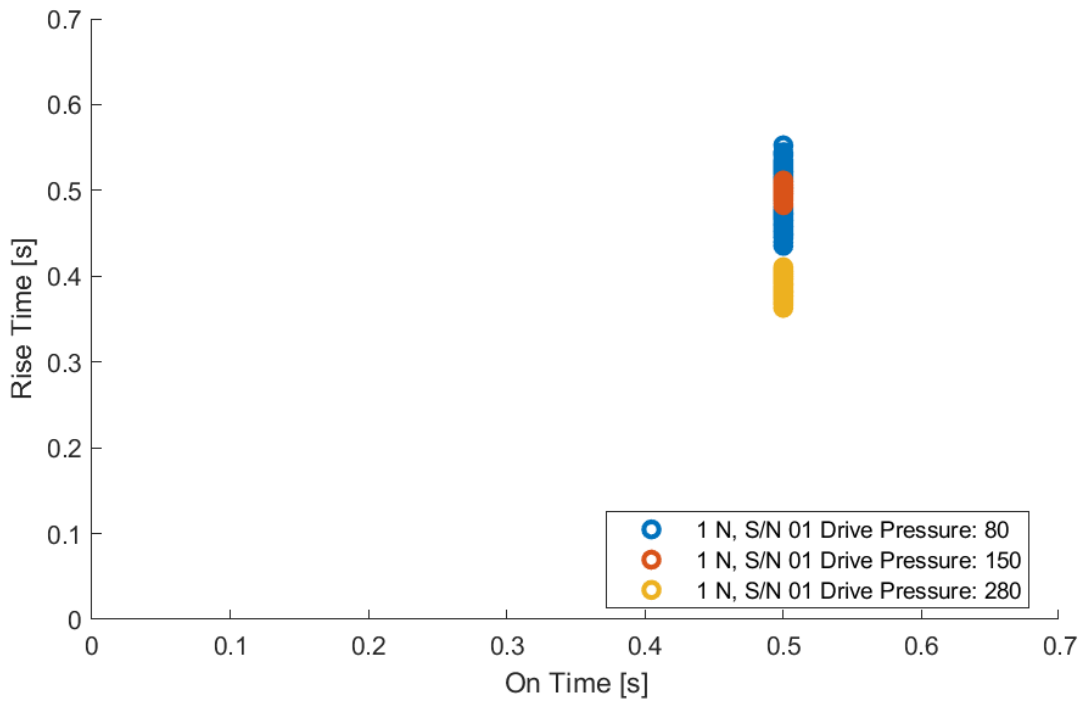

**Figure 118. Thruster valve rise time as measured by the differential pressure transducer against the on time for 1 N thruster valves for all reservoir pressures for on times of 0.5 s and off times of 0.5 s.**

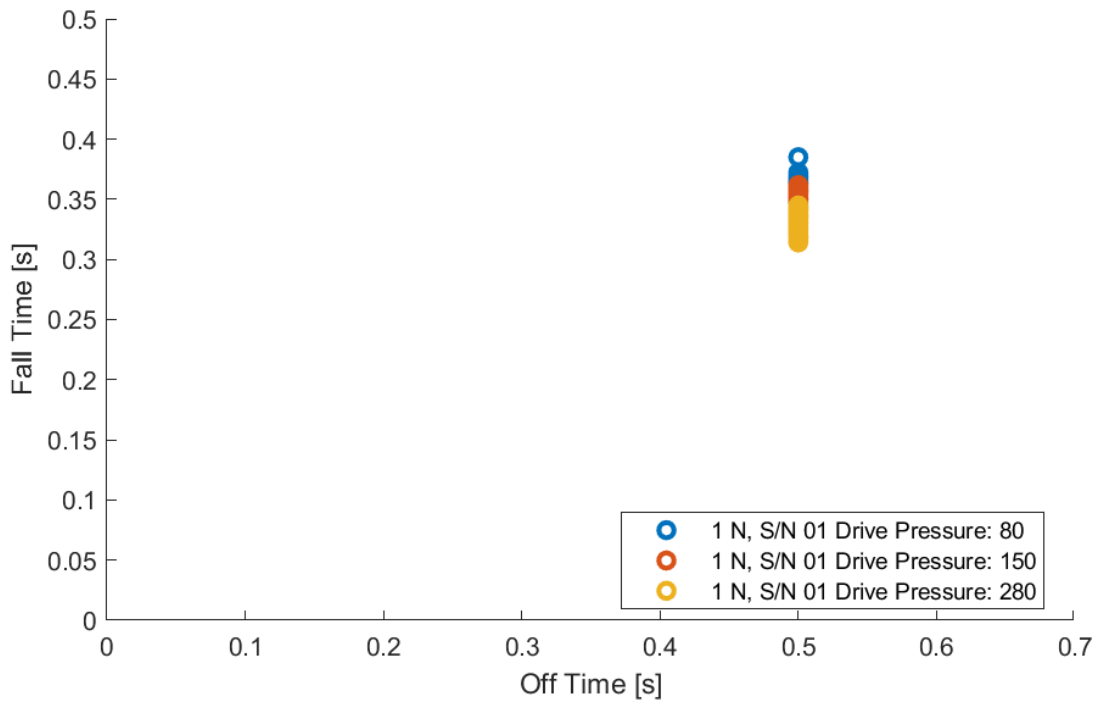

**Figure 119. Thruster valve fall time as measured by the differential pressure transducer against the on time for 1 N thruster valves for all reservoir pressures for on times of 0.5 s and off times of 0.5 s.**

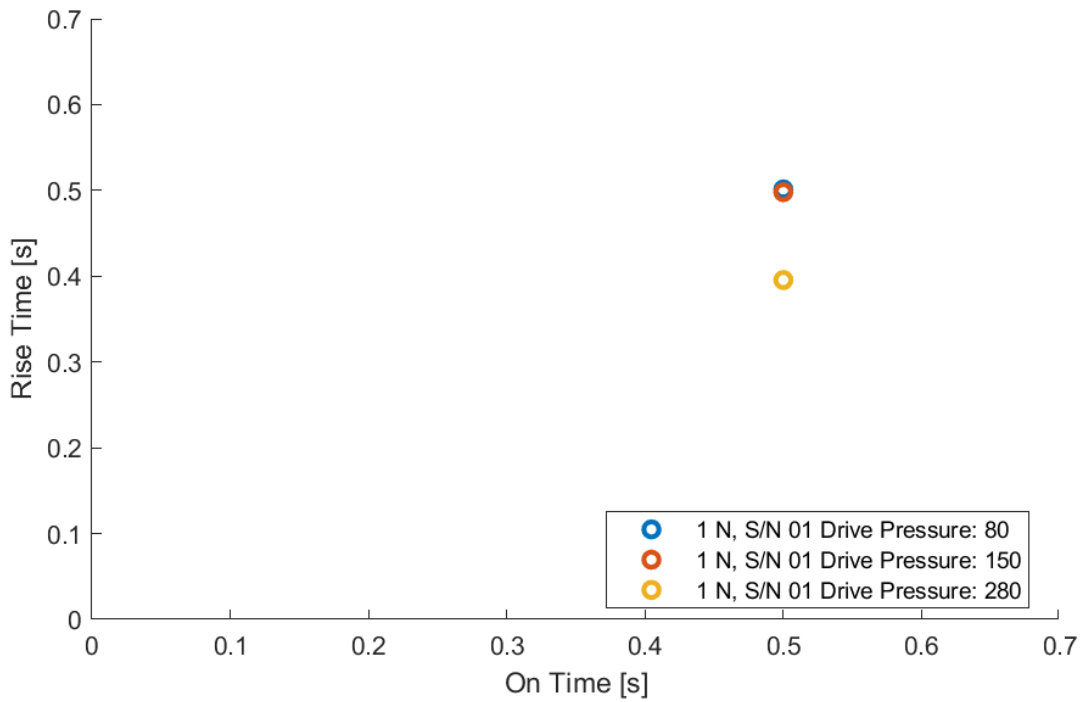

**Figure 120. Thruster valve average rise time as measured by the differential pressure transducer against the on time for 1 N thruster valves for all reservoir pressures for on times of 0.5 s and off times of 0.5 s.**

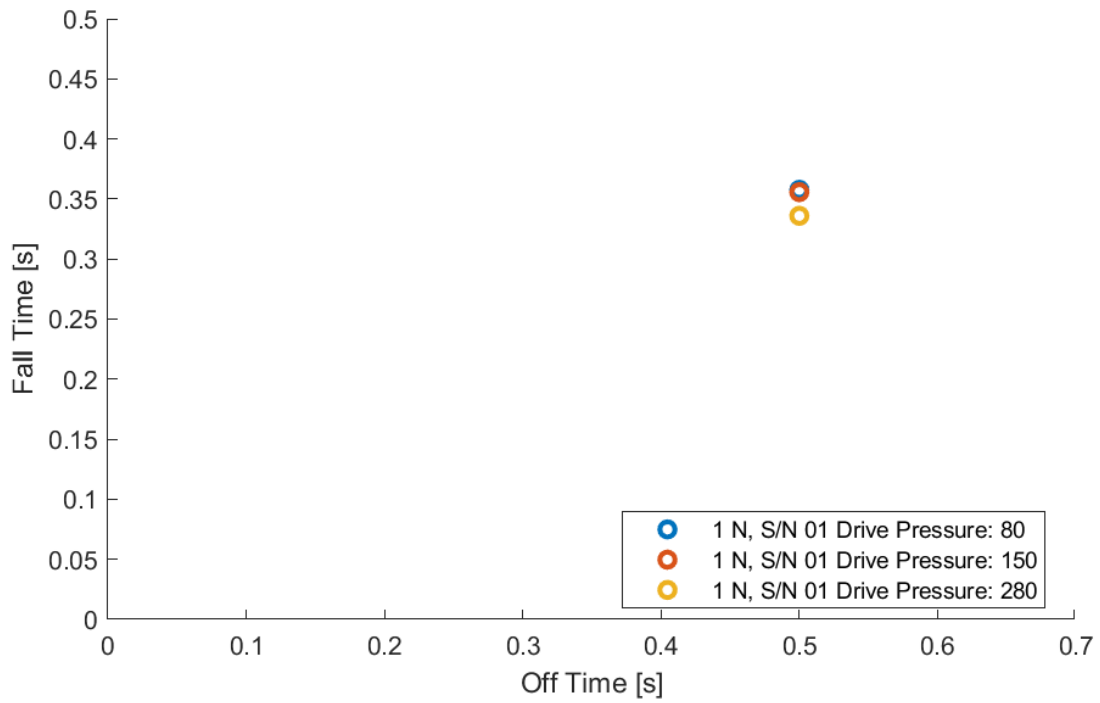

**Figure 121. Thruster valve average fall time as measured by the differential pressure transducer against the on time for 1 N thruster valves for all reservoir pressures for on times of 0.5 s and off times of 0.5 s.**

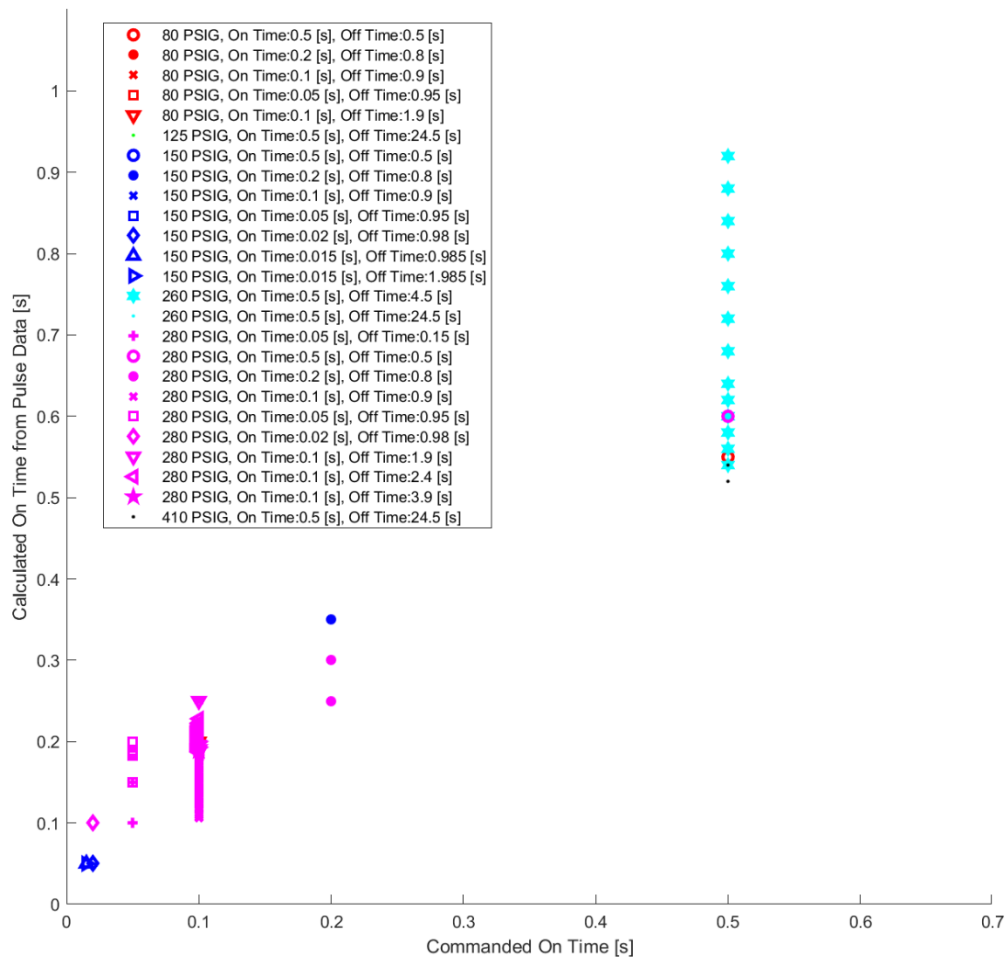

**Figure 122. Thruster valve calculated on time measured by the differential pressure transducer versus the commanded on time for all propellant reservoir head pressures and all commanded on times for the 1 N thruster valves.**

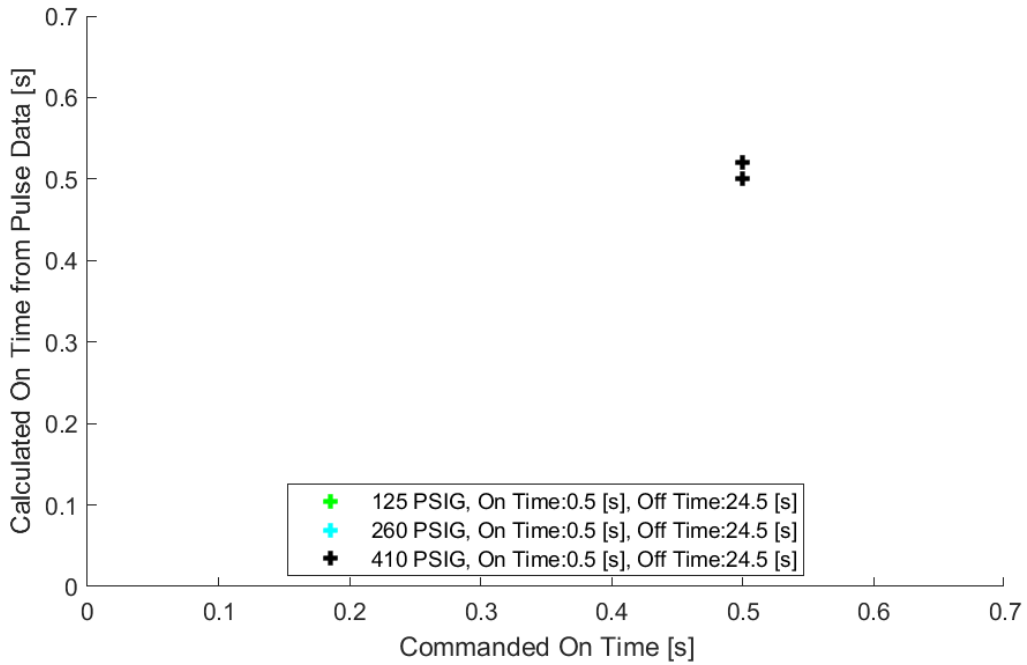

**Figure 123. Thruster valve calculated on time measured by the differential pressure transducer verses the commanded on time for all propellant reservoir head pressures and all commanded on times for the 22 N thruster valves.**

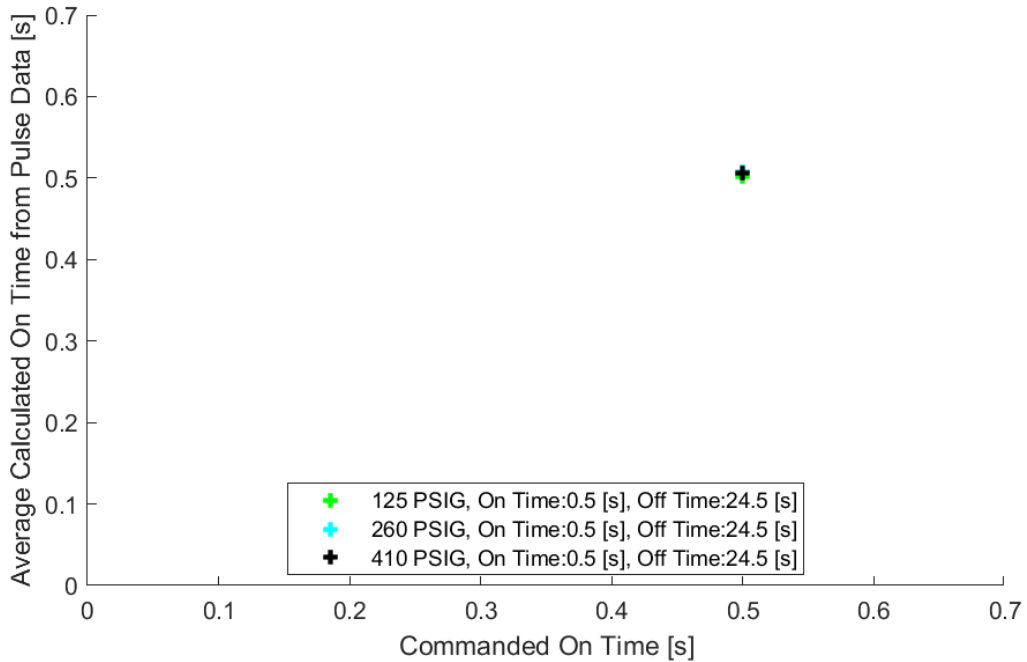

**Figure 124. Thruster valve calculated average on time measured by the differential pressure transducer verses the commanded on time for all propellant reservoir head pressures and all commanded on times for the 22 N thruster valves.**

## Acknowledgments

The authors would like to thank the following people who made this work possible. Chris McLean, GPIM Principal Investigator (Ball Aerospace & Technologies), for requesting testing and coordinating through the TDM program funding to perform this work. Adam Brand and Paul Zuttarelli (Air Force Research Laboratory) for providing propellant handling overview as well as all test propellant. Aerojet Rocketdyne for providing GPIM design information and a portion of the test hardware. Caitlin E. Bacha, Stephen A. McKim, and Graham K. Webster (NASA/GSFC) for their support in designing the experiment and conducting testing. Michael J. Mahon (NASA/GSFC) for his assistance with designing and installing the thruster valve actuating electronics and measurement equipment. Kyle Bentley, Mike Wilks, and Hal Baesch (NASA/GSFC) for testing and hardware support.

## References

<sup>1</sup>McLean, C.H, Hale, M.J., Deininger, W. D., Spores, R.A., Frate, D.T., Johnson, W.L., Sheehy, J.A, “ Green Propellant Infusion Mission Program Overview”, 49th AIAA/ASME/SAE/ASEE Joint Propulsion Conference, San Jose, CA, July 2013.

<sup>2</sup>Driscoll, R. and McKim, S., *Analysis of the AF-M315E GSFC Flow and Surge Pressure Test Data*, 62nd JANNAF Propulsion Meeting; Programmatic & Industrial Base Meeting; and the Joint Meeting of the 10th Modeling & Simulation, 8th Liquid Propulsion, and 7th Spacecraft Propulsion Subcommittees, Nashville, TN (1-5 June 2015).