

HiLiftPW-2 Summary

C. L. Rumsey

NASA Langley Research Center

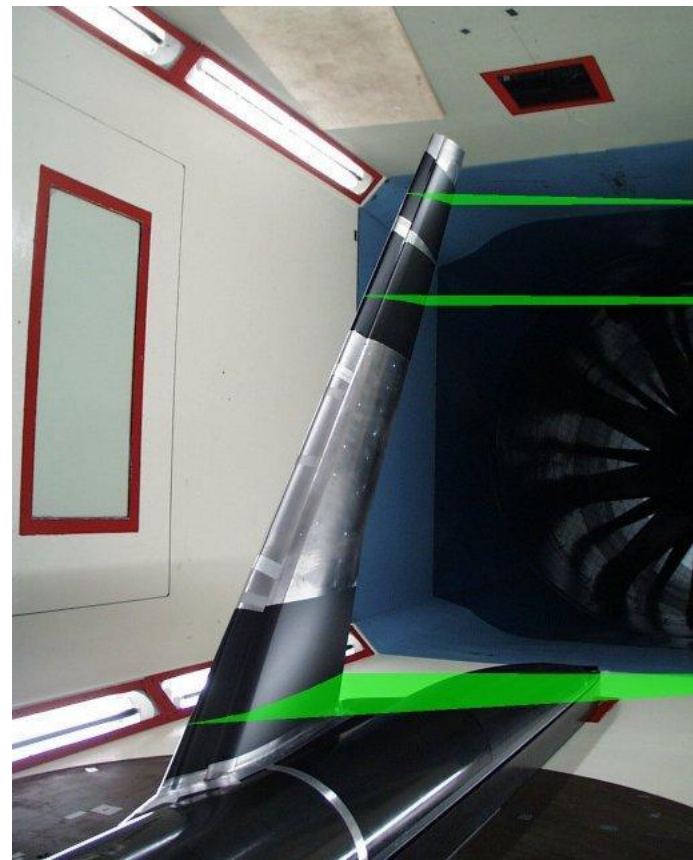

Overview

- Main goals of this summary
 - learn trends
 - make note of outliers
 - perform statistical analysis
- Many participants did not complete their study by the deadline, so many corrections & additions will no doubt be coming

Participants

ID	Code	Type	Grid	Turb	Other
002.1	FUN3D	uns	D	SA	
002.2	CFL3D	str	A	SA	
003.1	Overflow	ovr	E	SA	Incl trans
003.2	Overflow	ovr	E	SA-RC	
003.3	Overflow	ovr	E	SA-QCR2000	Incl trans
004	CFD++	uns	B	SA-RC	
005.1	HIFUN	uns	A	SA	
005.2	HIFUN	uns	B	SA	
006	FUN3D	uns	D	SA	
007.1	CFLOW	uns	C	SA	
007.2	UG3	uns	C	SA	
008	CRUNCH	uns	D	SST	
009	Overflow	ovr	E	SA	Incl trans?
010.1	CFD++	uns	A	SA	

Participants

ID	Code	Type	Grid	Turb	Other
010.2	CFD++	uns	A	SST	
010.3	CFD++	uns	A	K-e-Rt	
011.1	NSMB	str	A	SA	
011.2	NSMB	str	A	SA-Edwards	
012	PowerFlow	lb	nc	LBM-VLES	C3 only
013	UPACS	str	A	SA-noft2-R	
014	UNICORN	uns	nc	SGS	Adapt, C2b
015.1	CFX	uns	B	SST/GRET	Incl trans
015.2	FLUENT	uns	B	SST/GRET	Incl trans
016	ELSA	ovr	E	SA	
017	COBRA	str	nc	SA	
018	VULCAN	str	A	PANS	
020	Overflow	ovr	E	SA-noft2-RC	
021	TAU	uns	B	SA	Incl C3

Participants

ID	Code	Type	Grid	Turb	Other
022	PHASTA	uns	nc	SA	
023	NSU3D	uns	D	SA	
024.1	EDGE	uns	B	EARSM	
024.2	EDGE	uns	B	SA	
025	NSU3D	uns	nc	Wilcox	
026	MFLOW	str	A	SA	Incl C3
028	FLUENT	uns	A	SA-RC	
029	XFLOW	lb	nc	WMLES	

str=structured

uns=unstructured

ovr=overset (str)

lb=lattice boltzmann

A,B,C,D,E = committee grids

nc=non-committee grid created by participant

Summary

- Grid type:
 - 13 structured/overset
 - 21 unstructured
 - 2 Lattice-Boltzmann
- Grids:
 - 11 used A, 7 used B, 2 used C, 4 used D, 6 used E
 - 6 made their own
- Turb models
 - 25 used SA or variant
 - 4 used SST or variant
 - 3 other RANS
 - 4 scale-resolving type

Cases

- Case 1
 - Re=15.1 M, fully turbulent, no brackets
- Case 2
 - a) Re=1.35 M, fully turbulent, w brackets
 - b) Re=15.1 M, fully turbulent, w brackets
 - c) Re=1.35 M, transitional w brackets
- Case 3
 - a) Re=1.35 M, w brackets+bundles
 - b) Re=15.1 M, w brackets+bundles
- Case 4
 - Turbulence model 2-D verification study

Case 4 Turb model verification

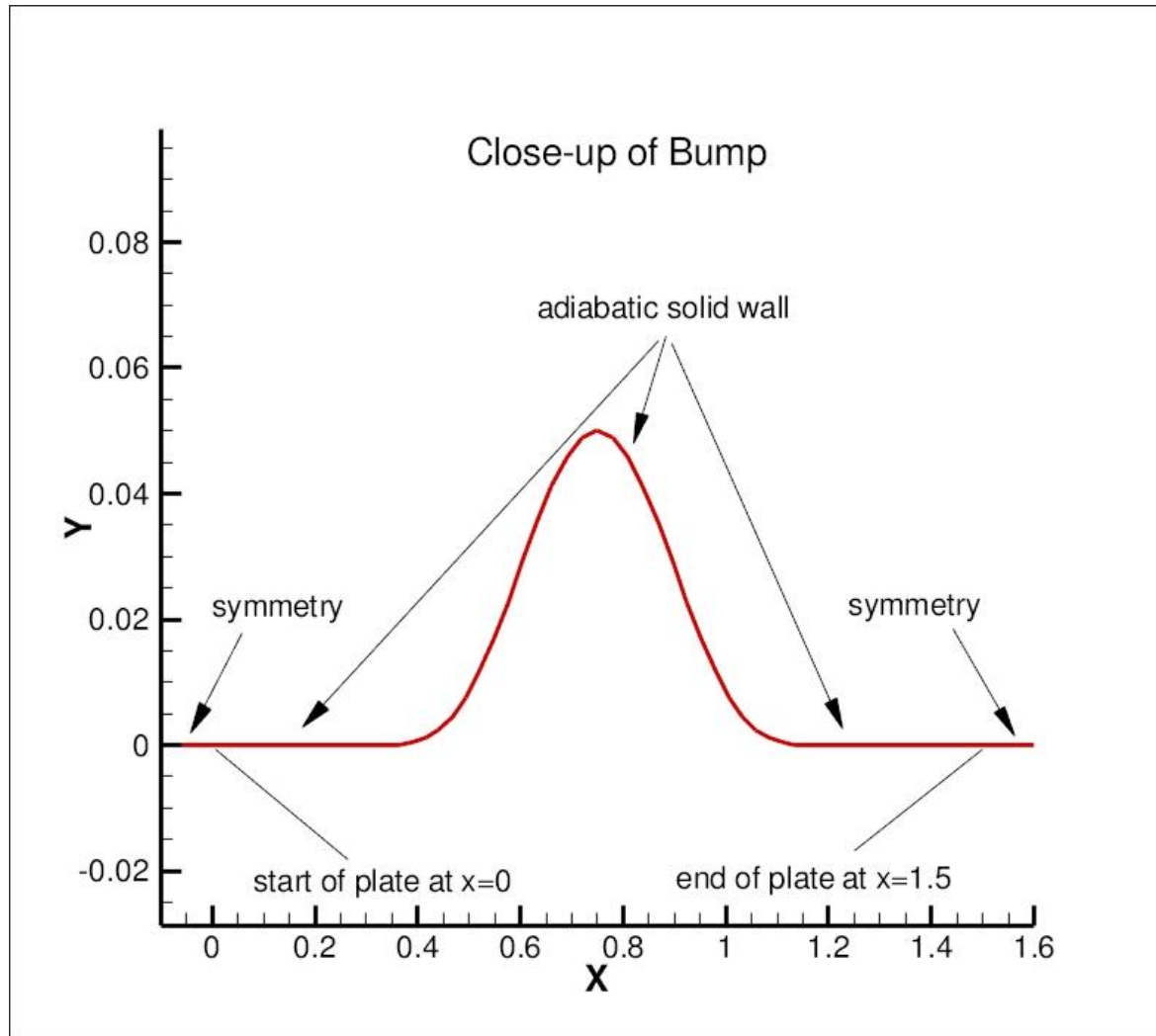

This case also used in DPW-5 (see AIAA-2013-0046)

Case 4 Turb model verification

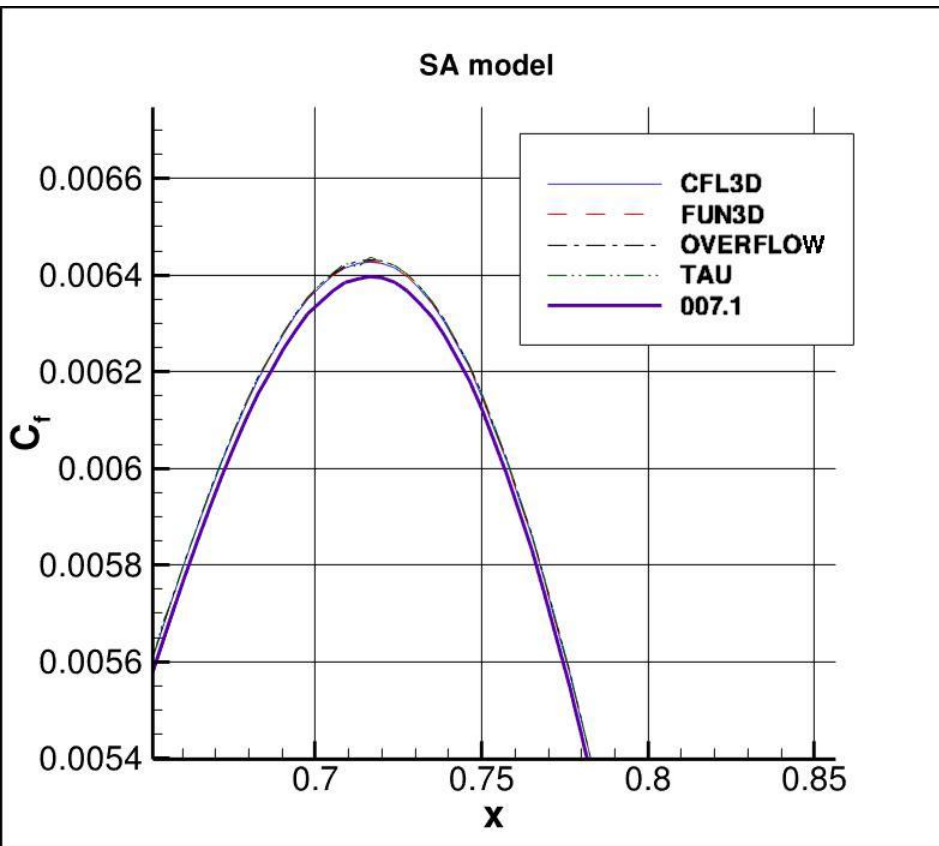

Very small difference between 007.1 result and other codes

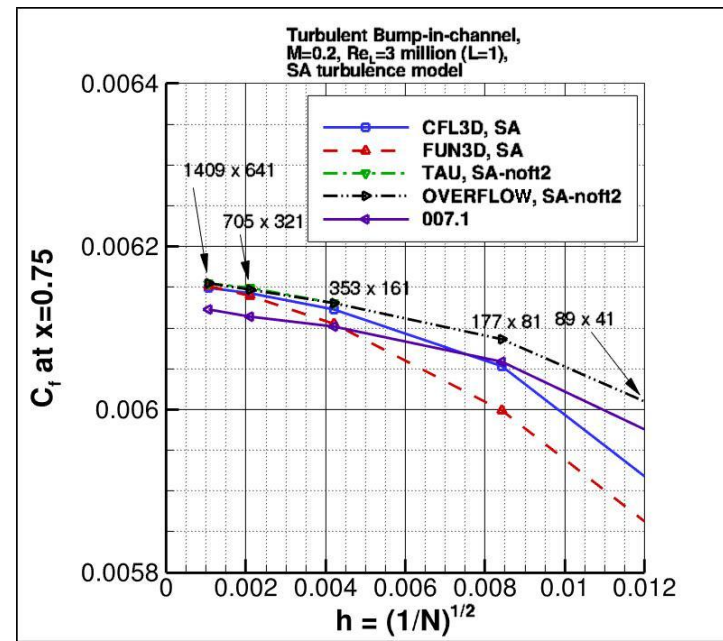
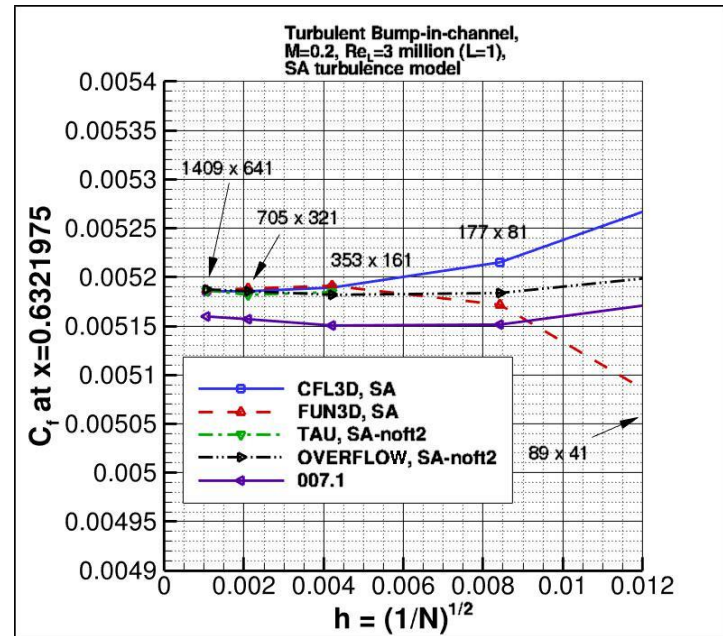

Case 4 Turb model verification

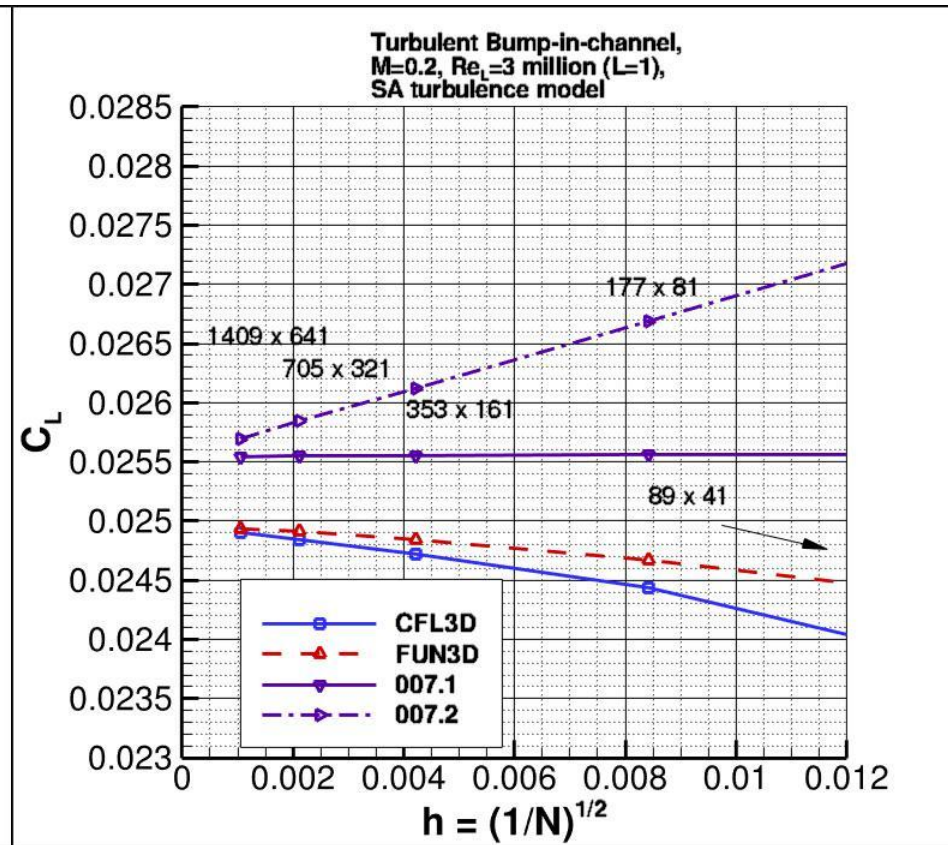
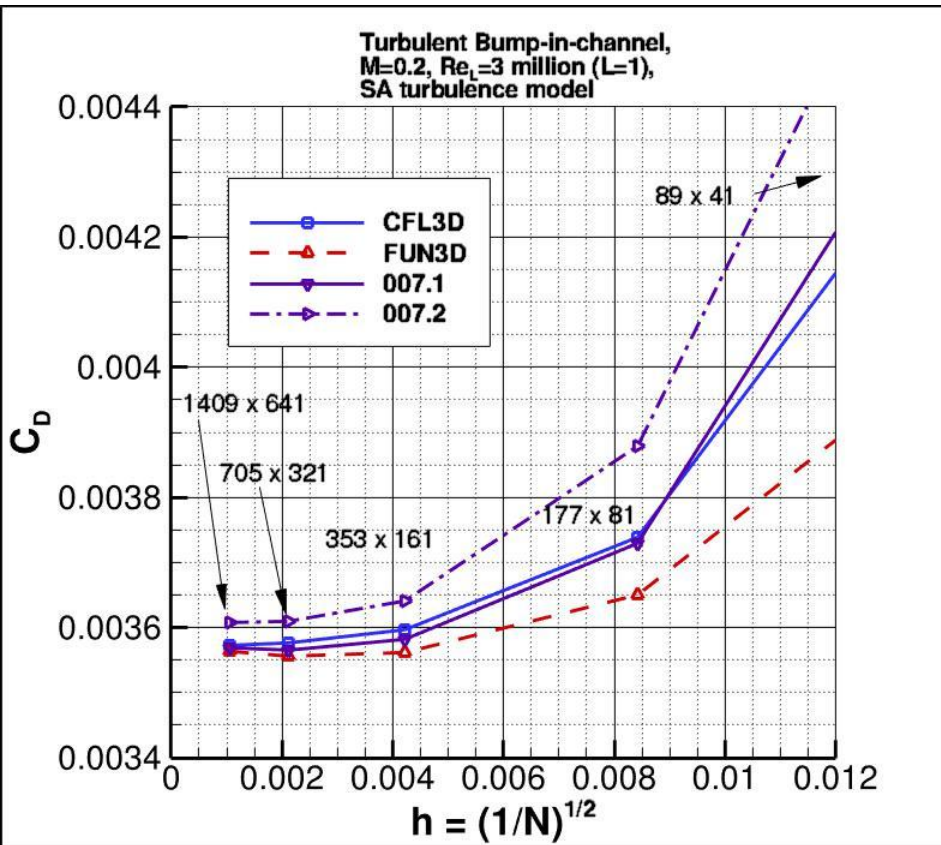

Very small difference between 007.1 result and other codes

Accurate min distance is particularly important for SA model

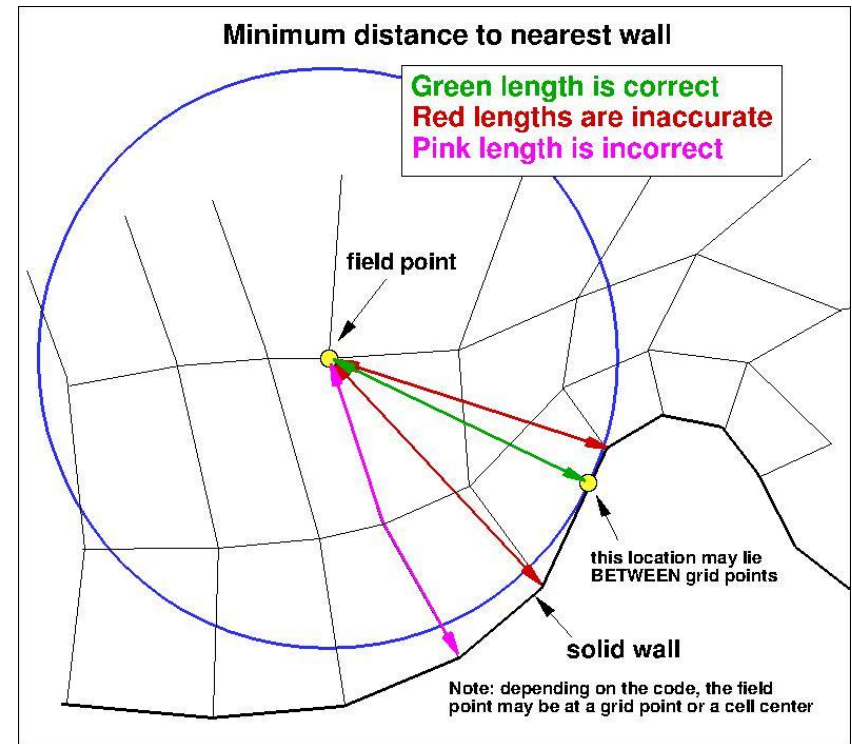
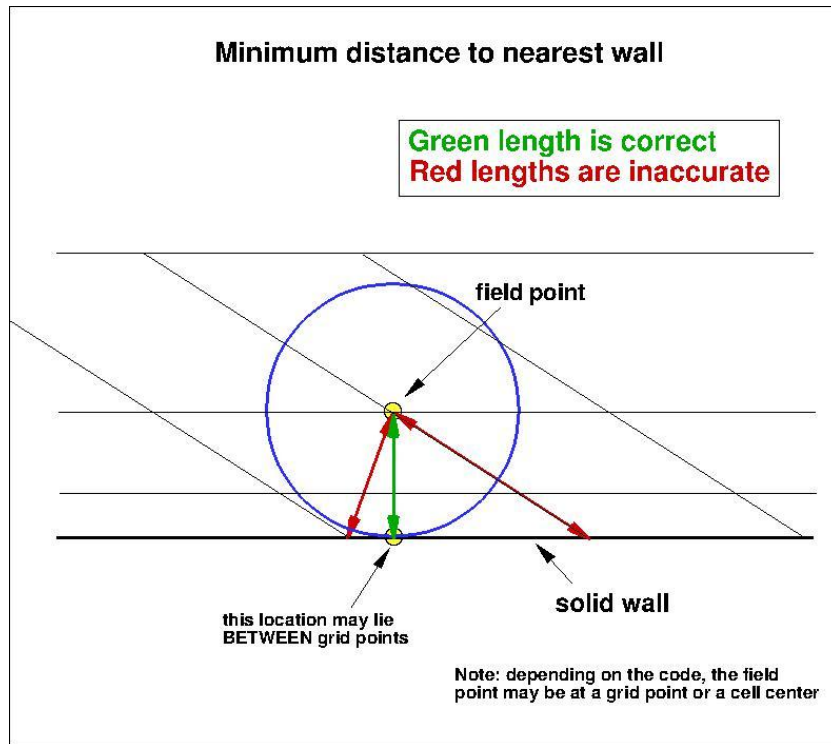

Case 4 Turb model verification

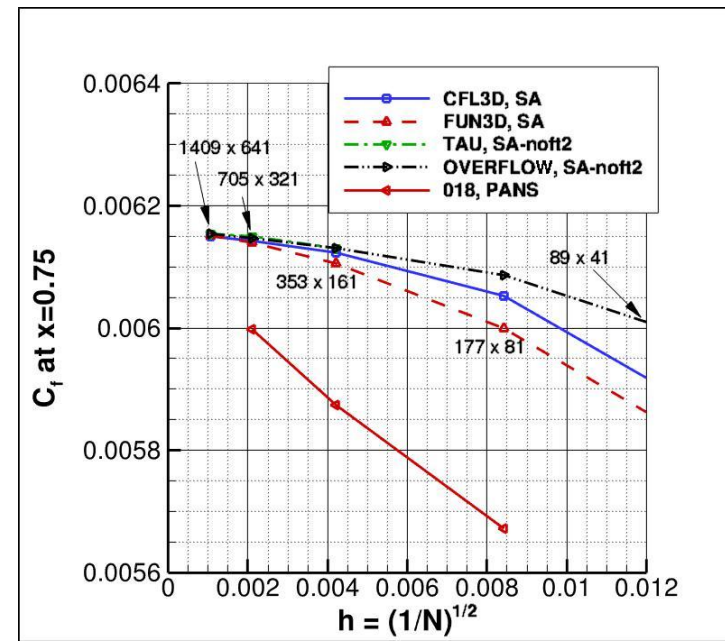
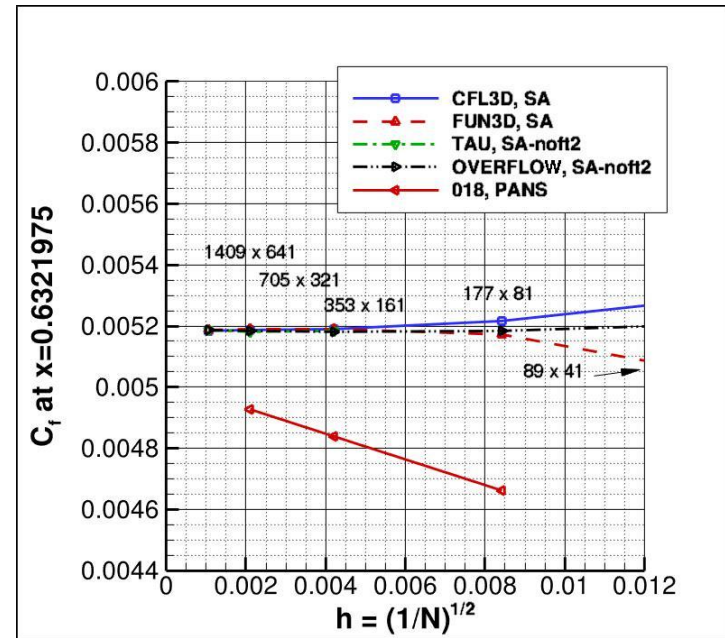
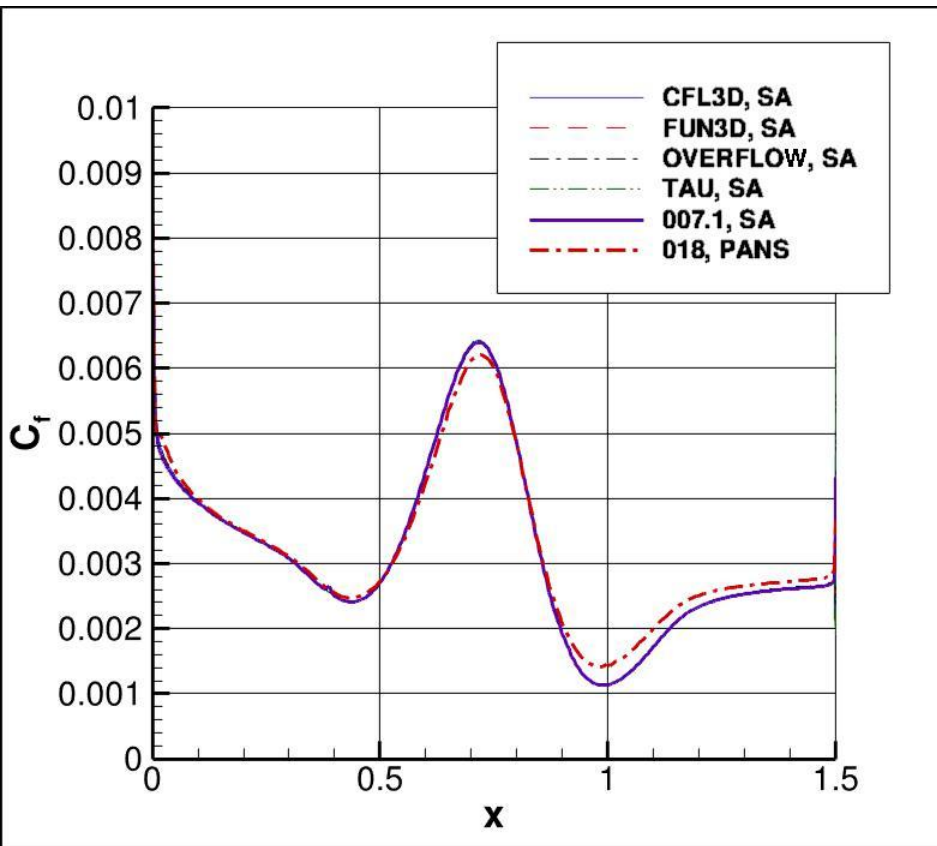

DLR F11 EUROLIFT configuration



Case 1, Lift curve

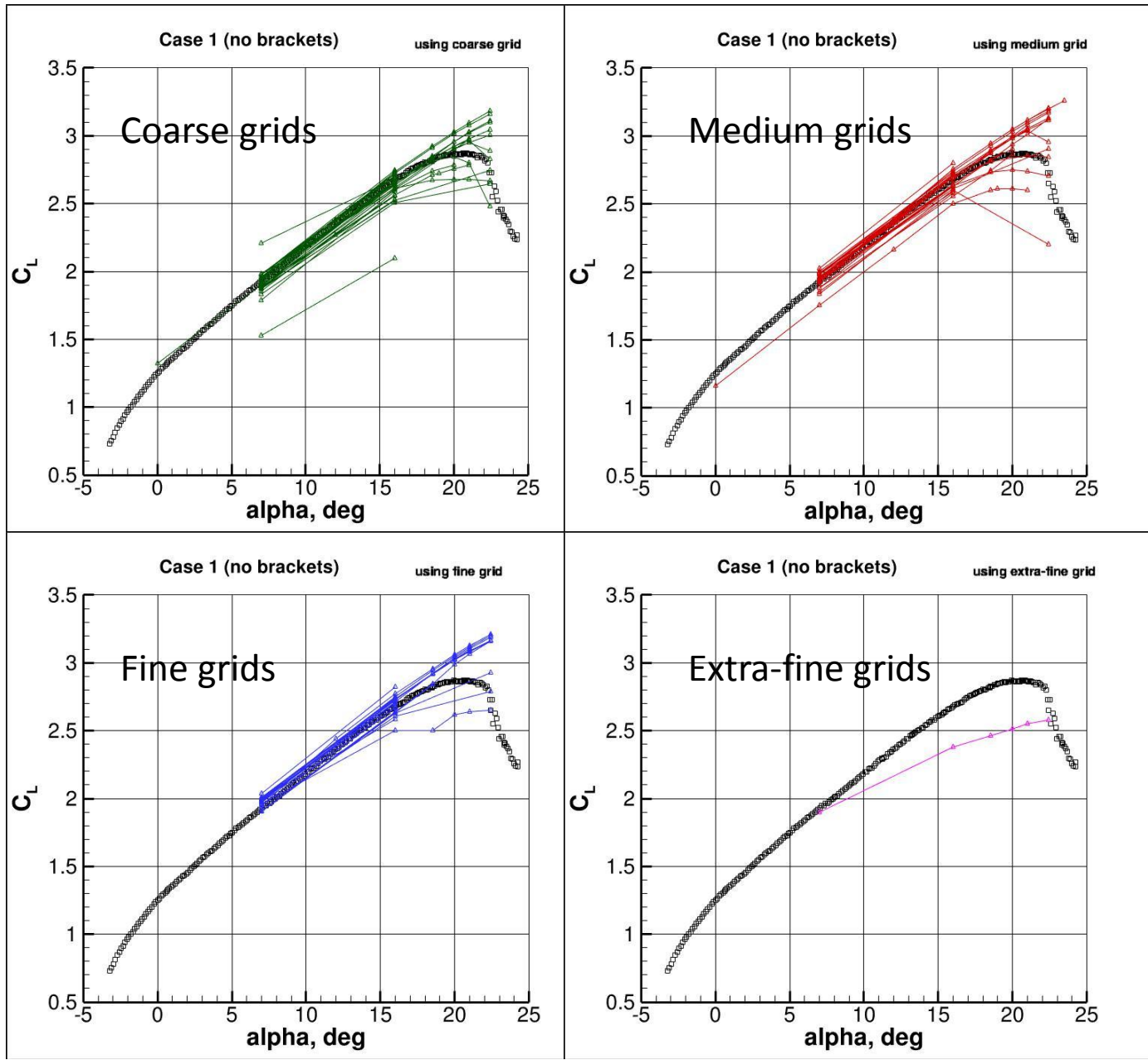

Case 1, Drag polar

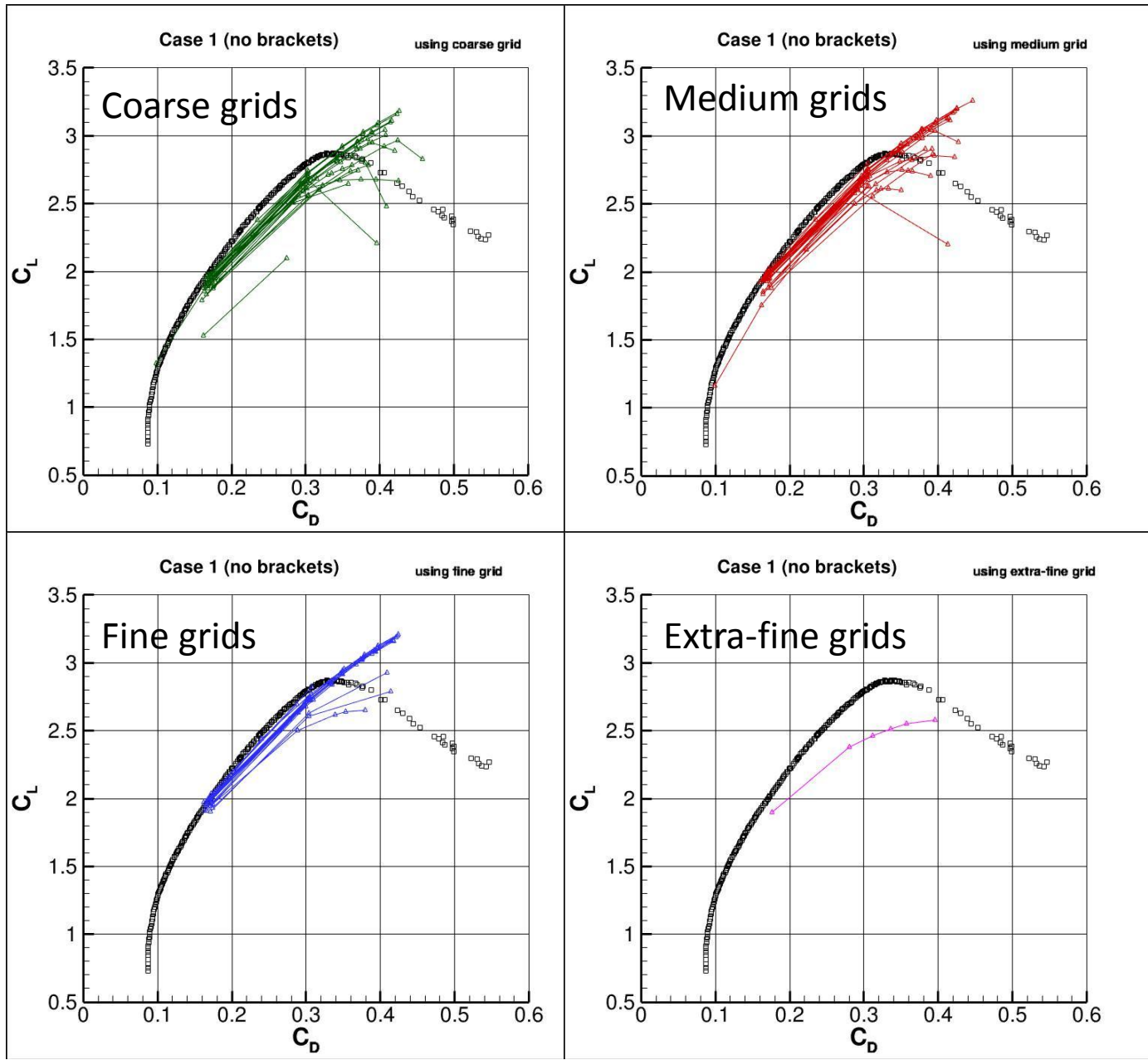

Case 1, Moment polar

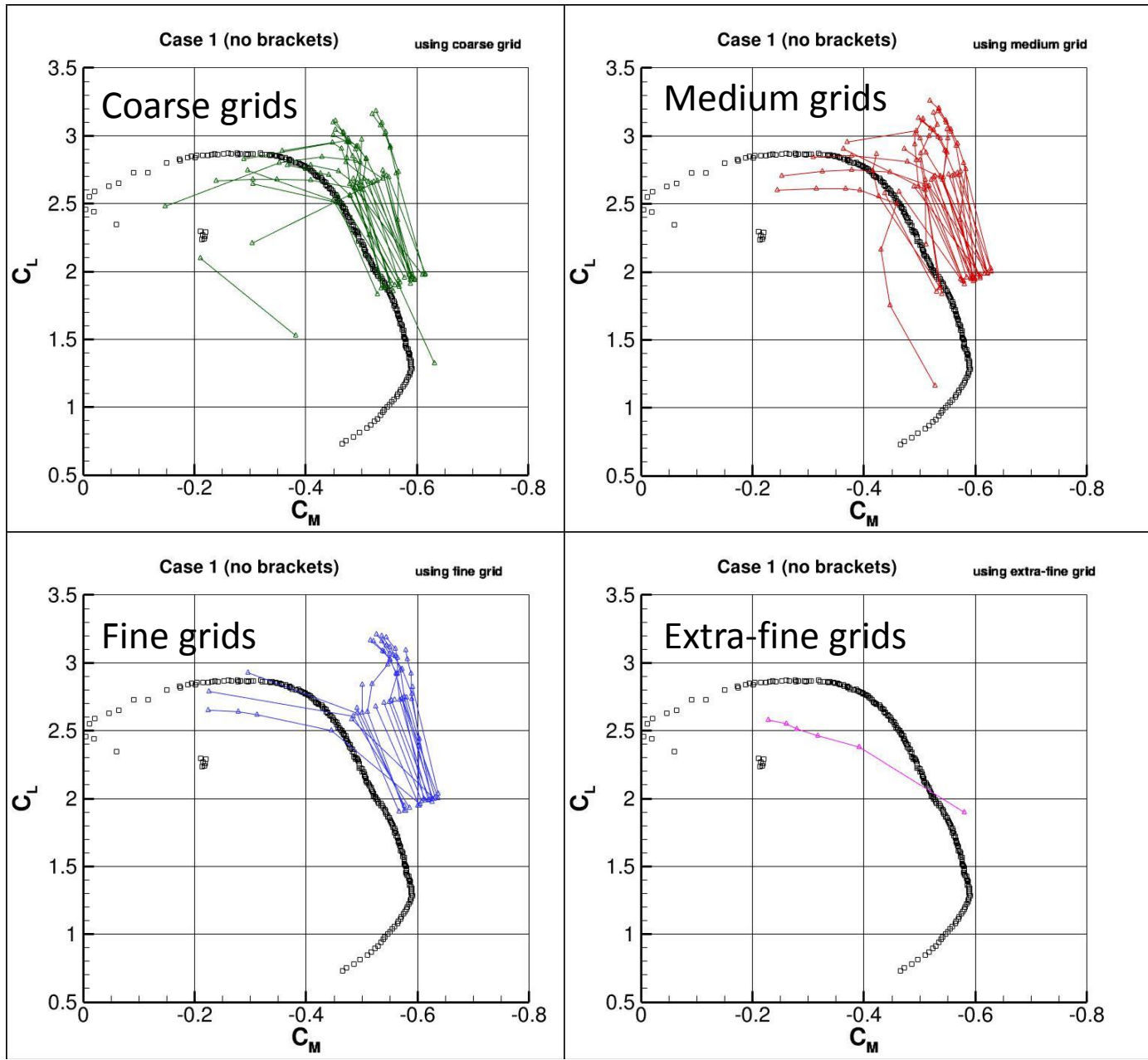

Case 1 Lift curve with variation, M

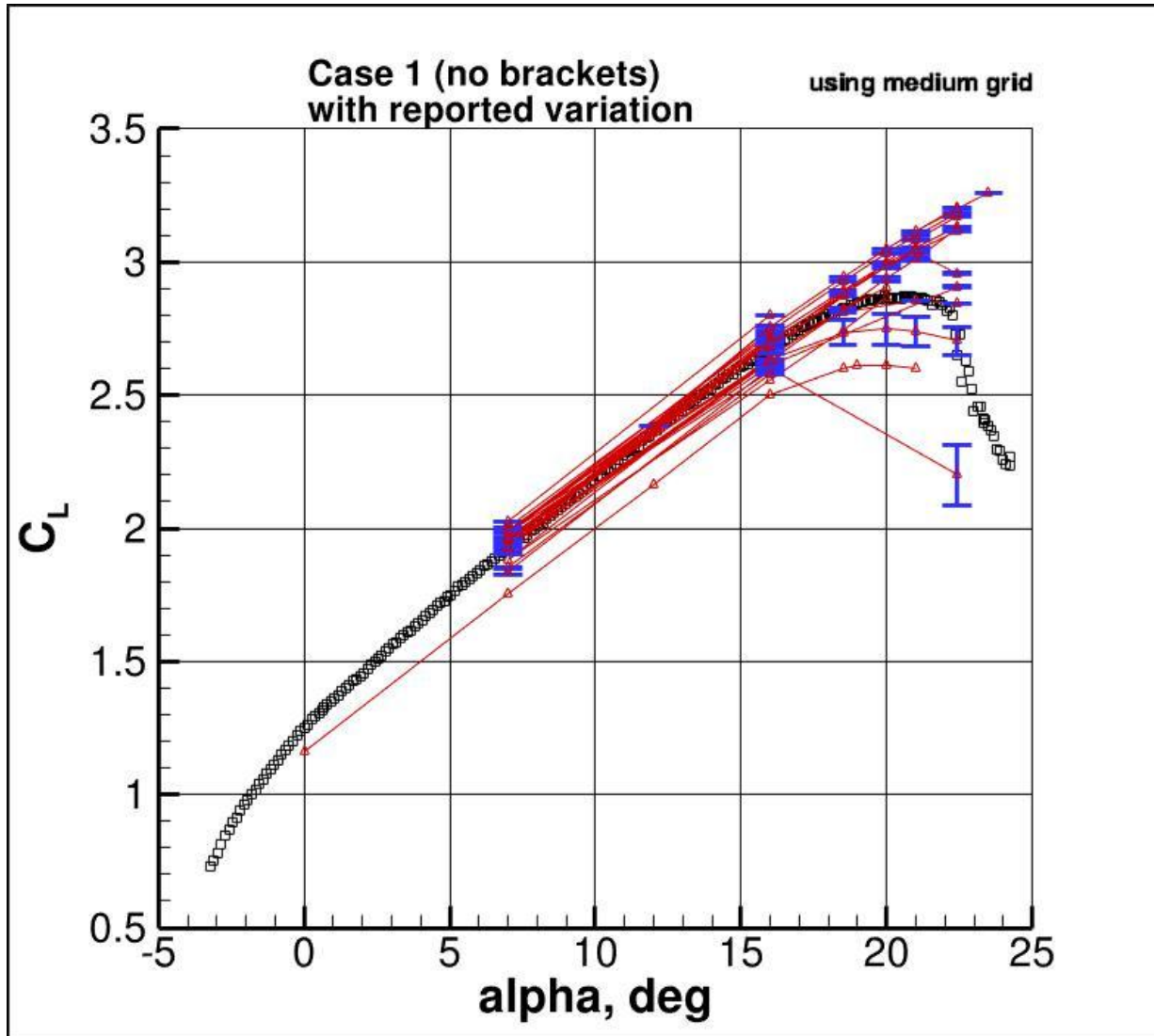

Those above exp lift curve reported very small variations; those below reported larger variations

Case 1 Drag polar with variation, M

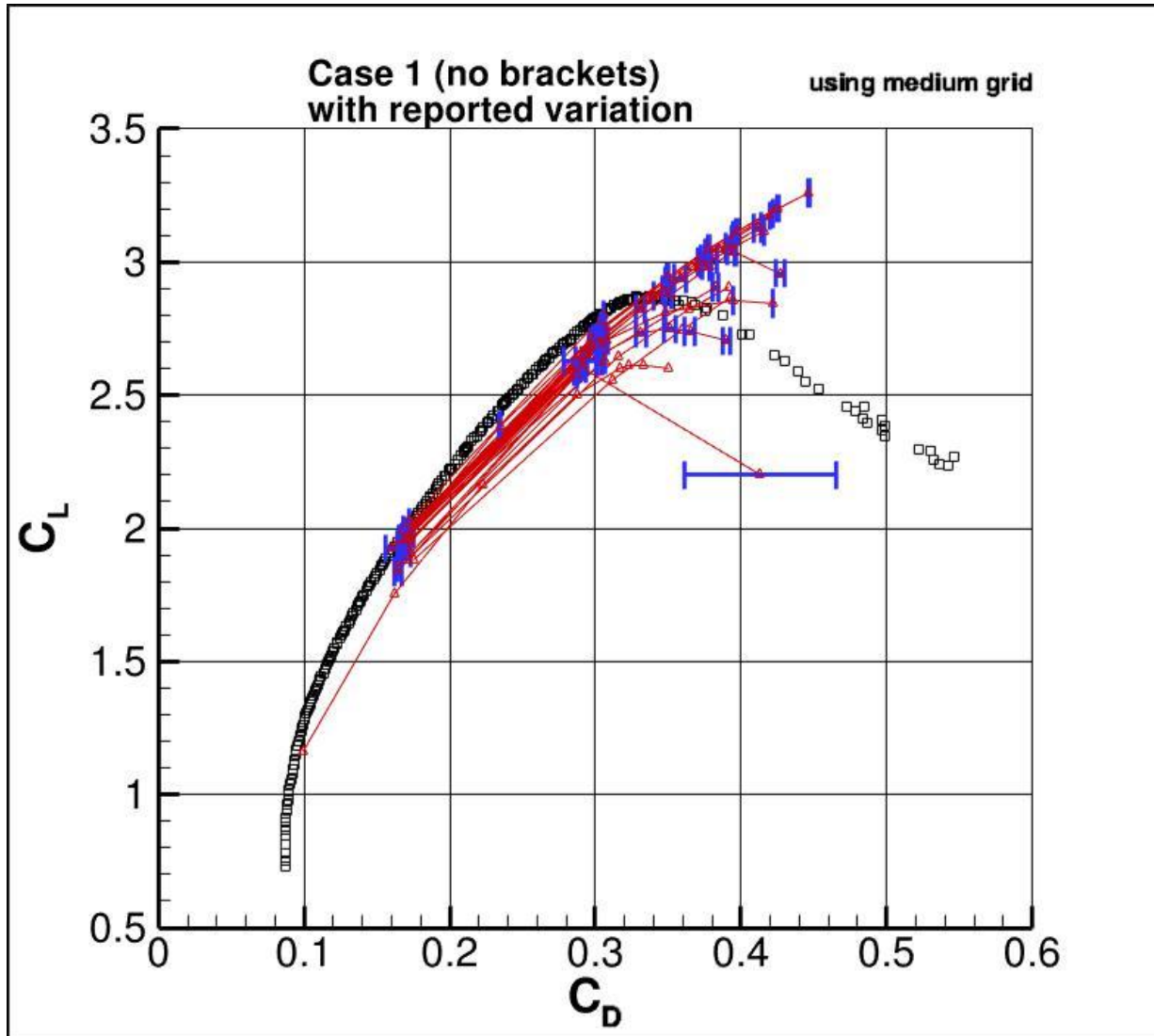

Case 1 Moment polar with variation, M

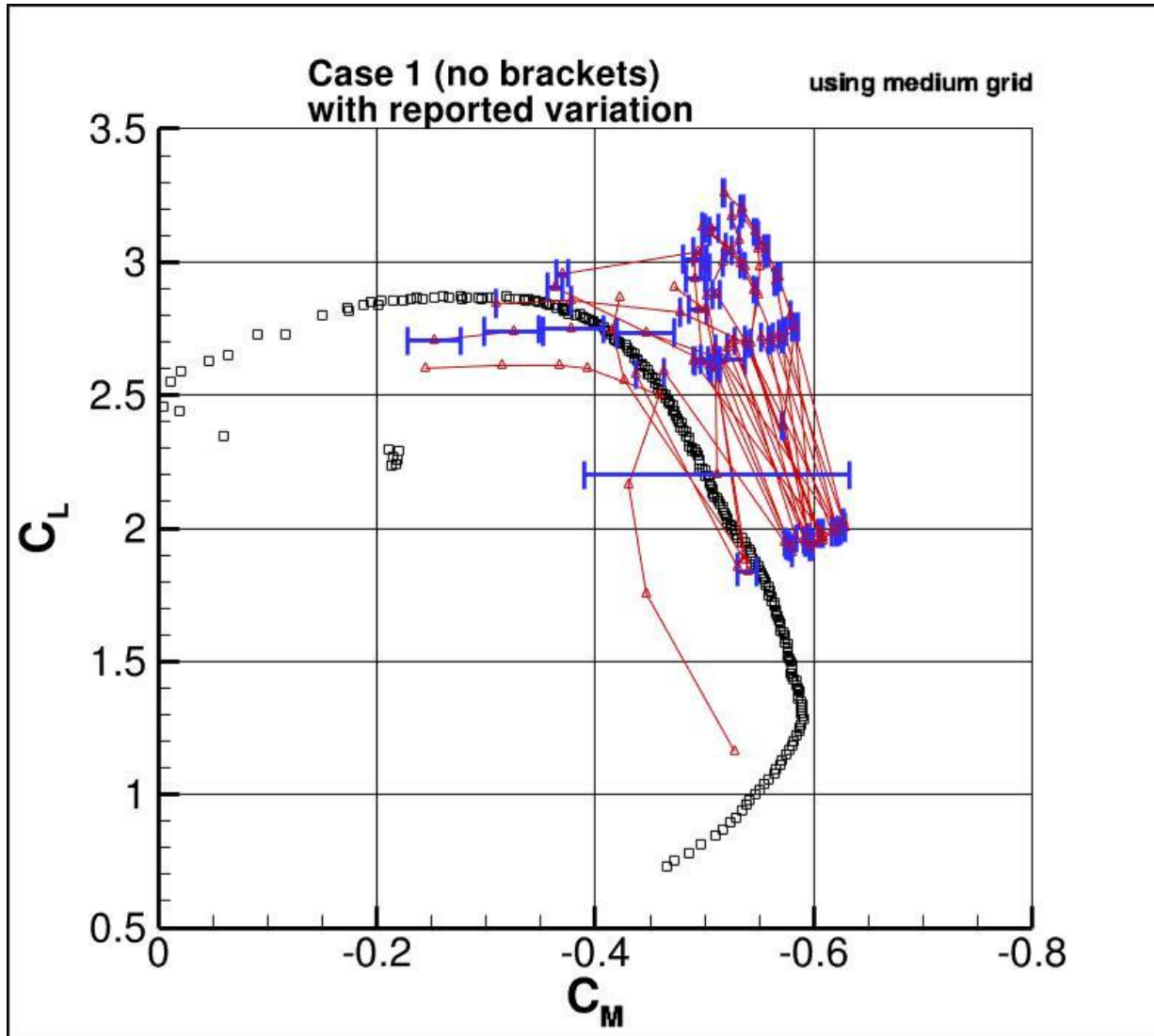

Case 1 Grid convergence, AoA=7

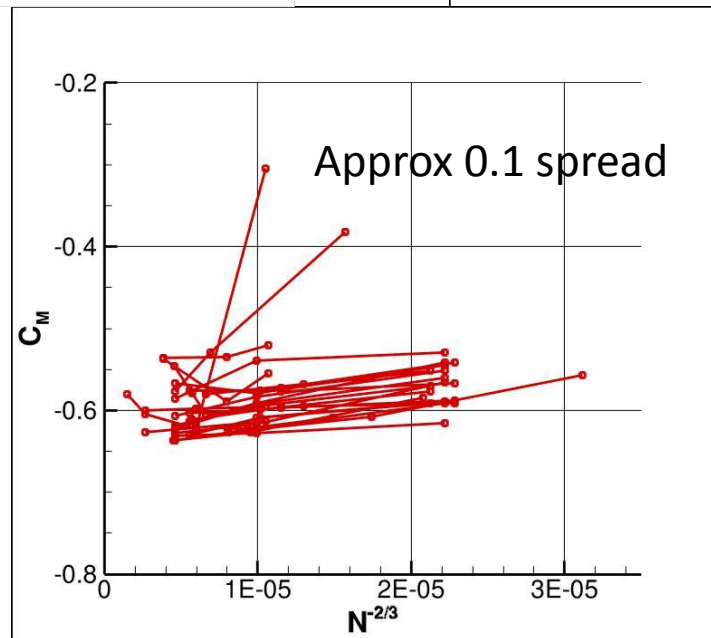
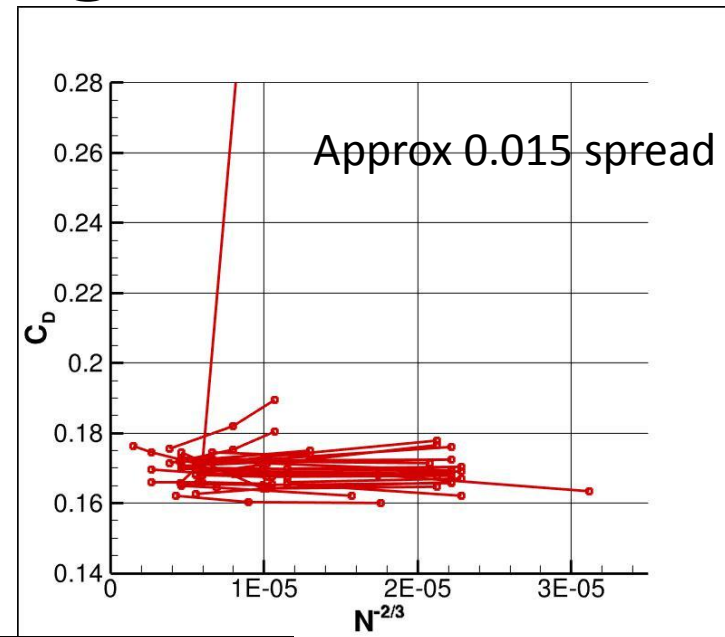
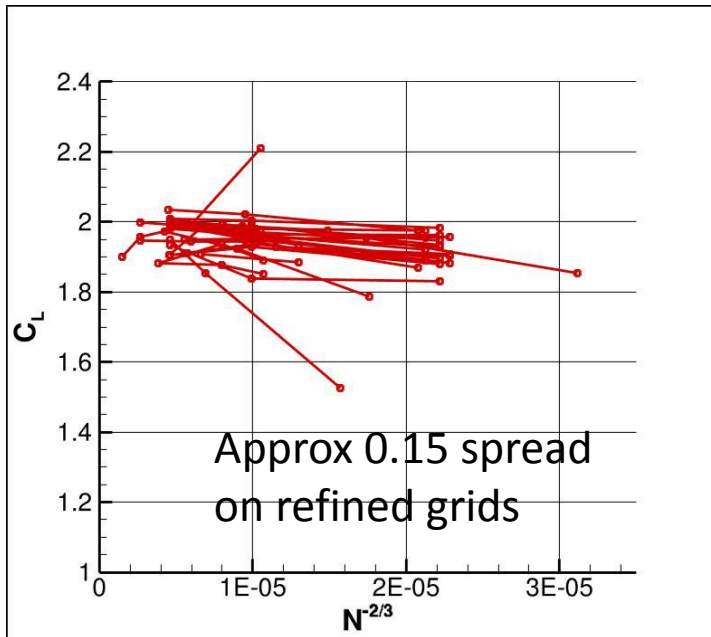

Case 1 Grid convergence, AoA=16

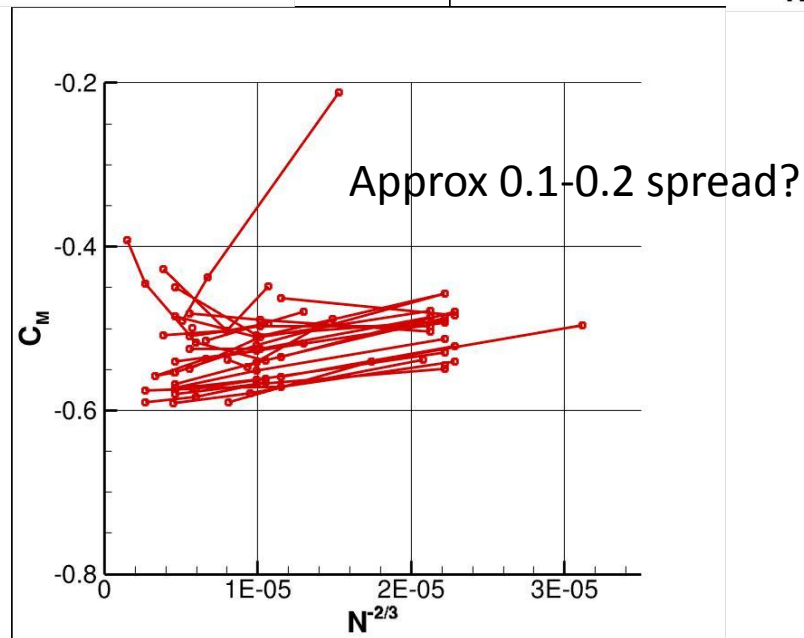
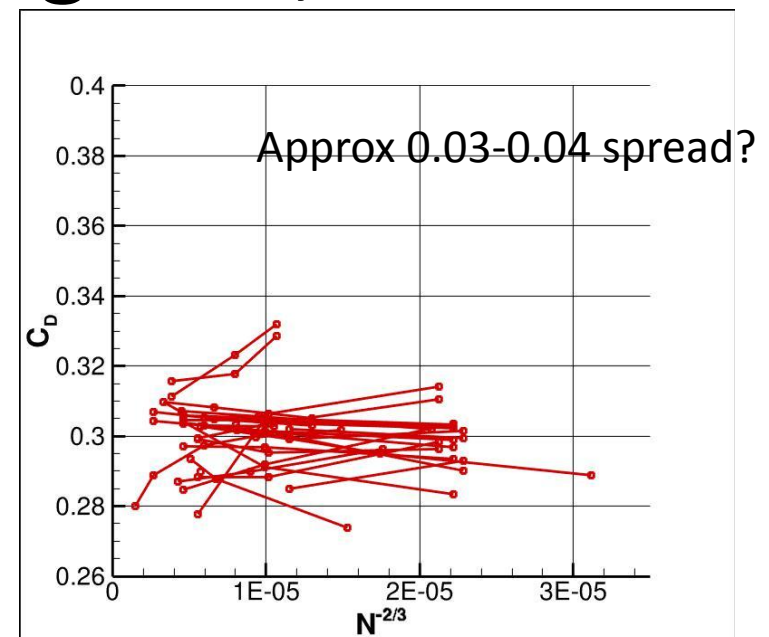
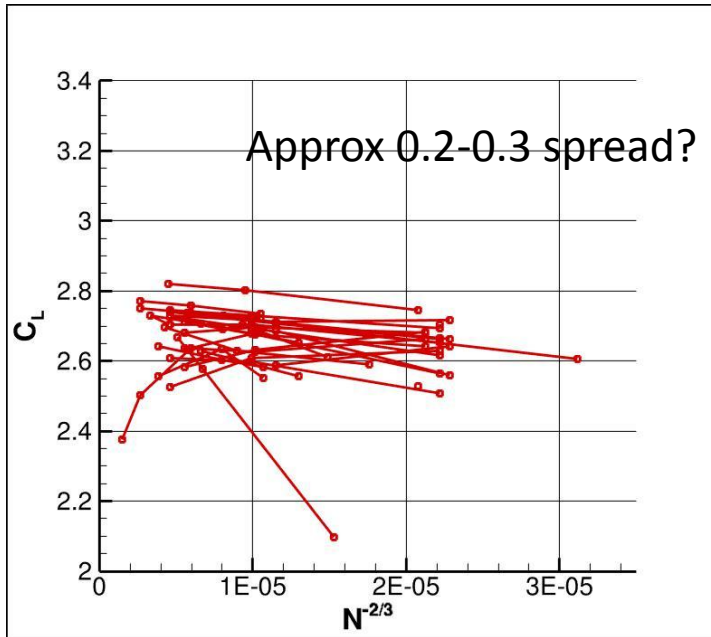

Case 1 Grid convergence, AoA=18.5

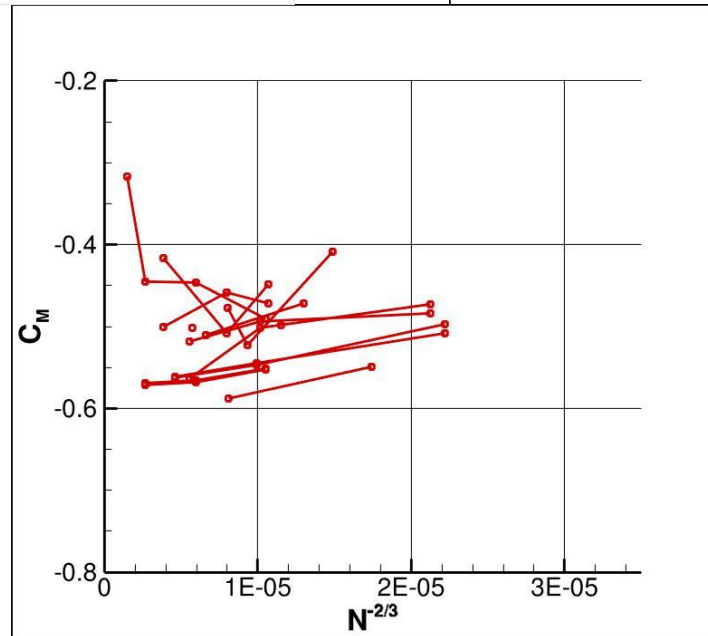
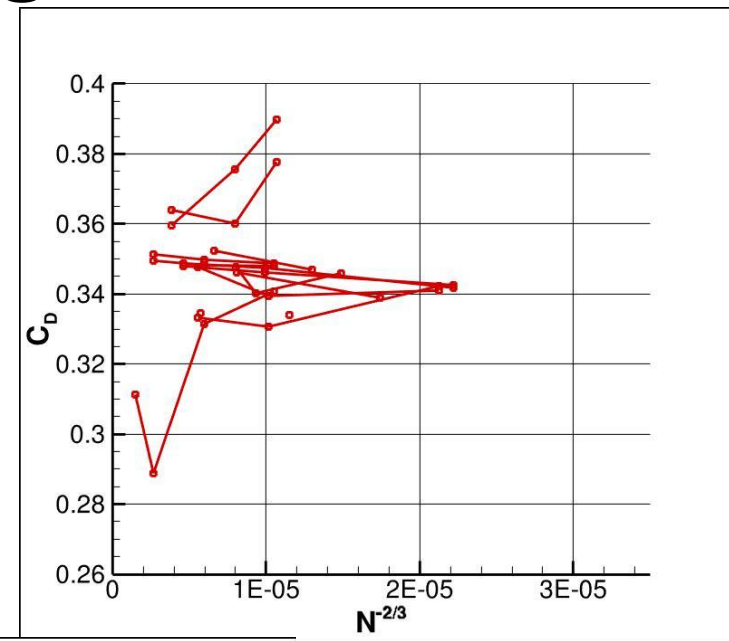
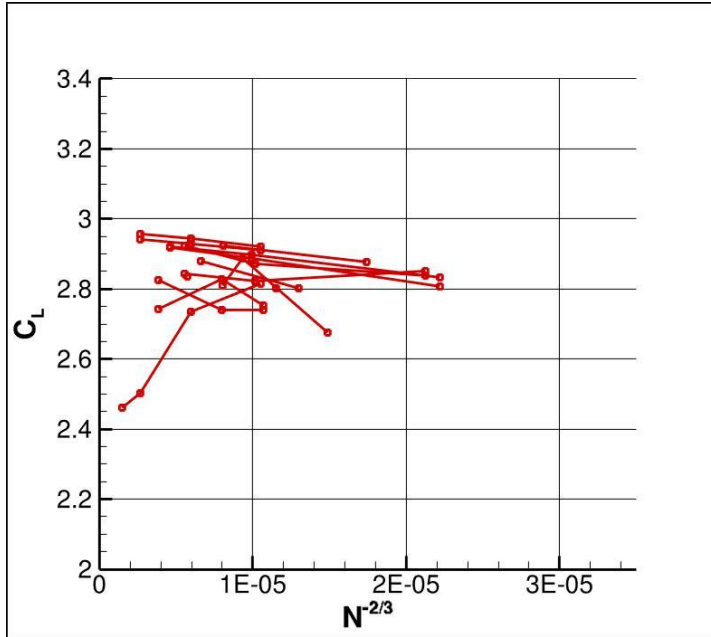

Much more difficult to tell where soln going at higher AoAs

Case 1 Grid convergence, AoA=20

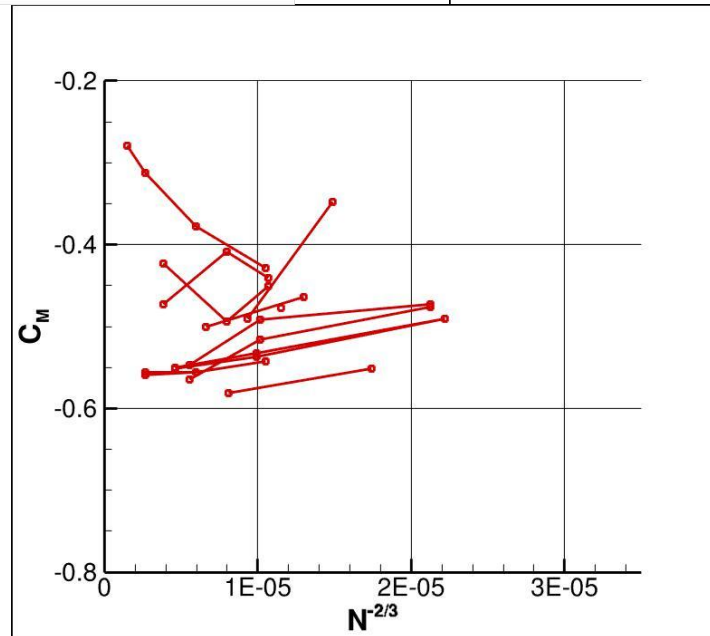
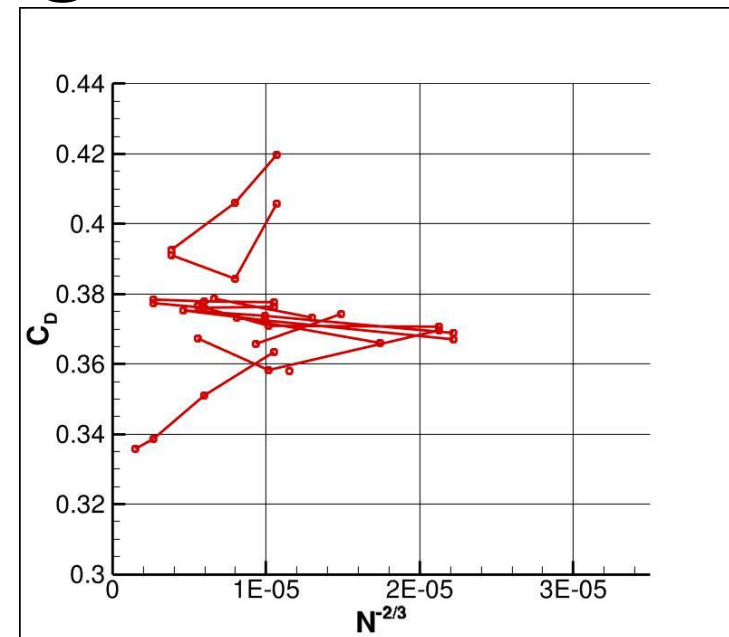
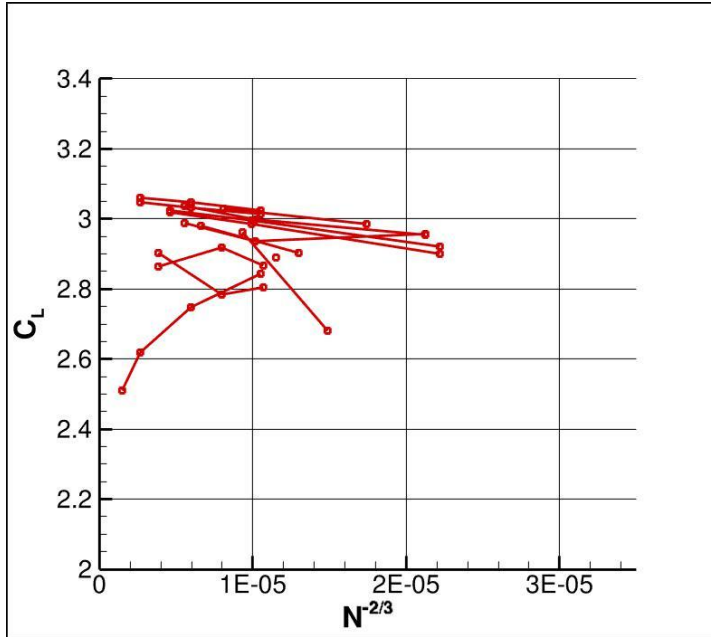

Much more difficult to tell where soln going at higher AoAs

Case 1 Grid convergence, AoA=21

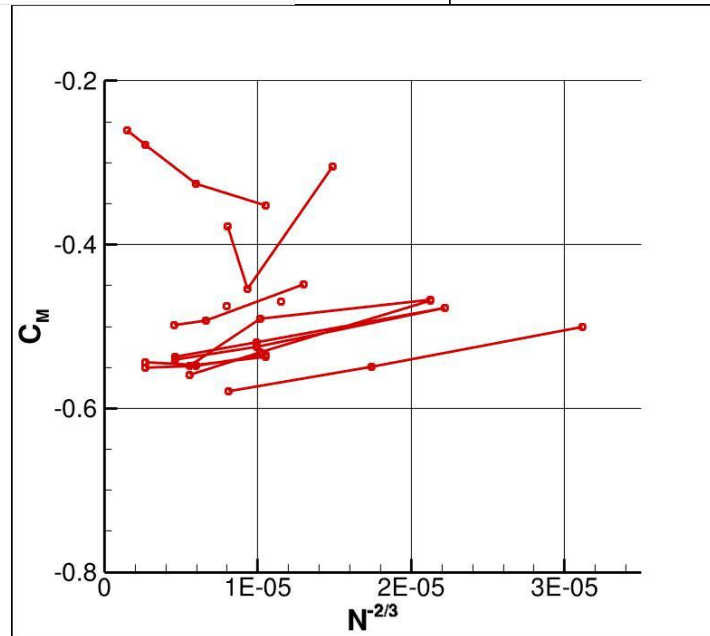
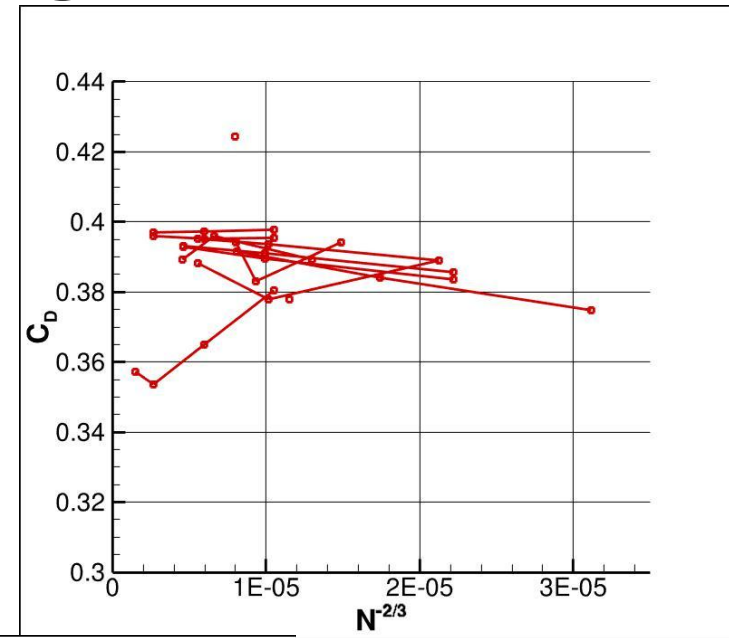
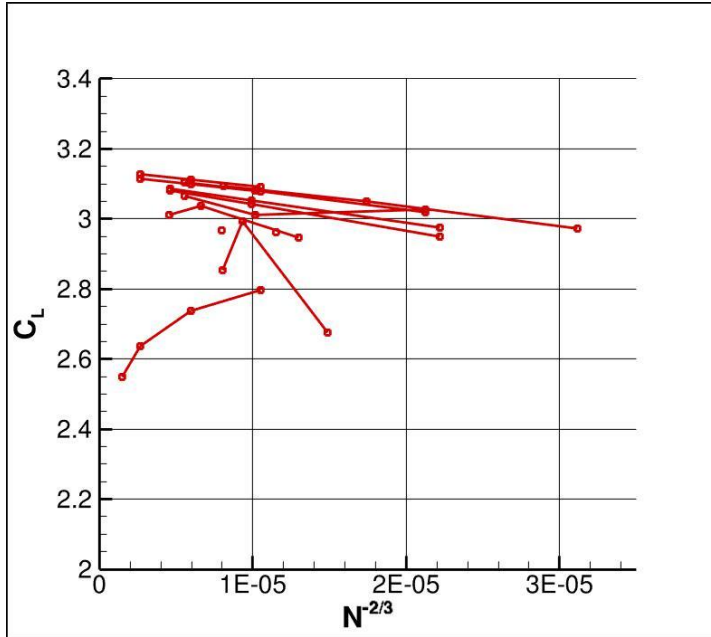

Much more difficult to tell where soln going at higher AoAs

Case 1 Grid convergence, AoA=22.4

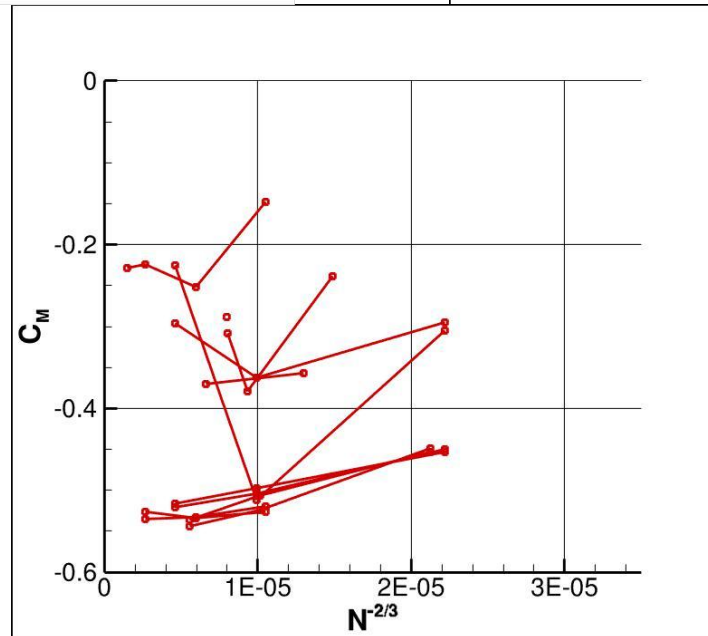
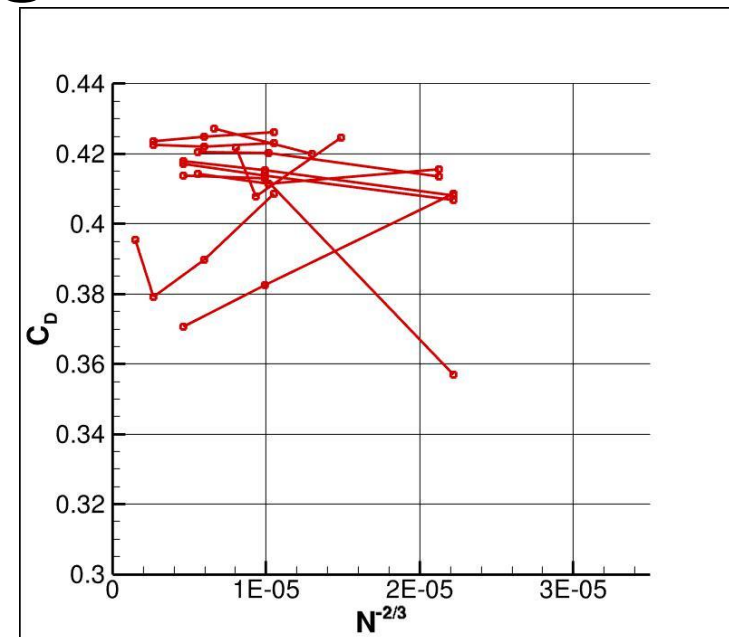
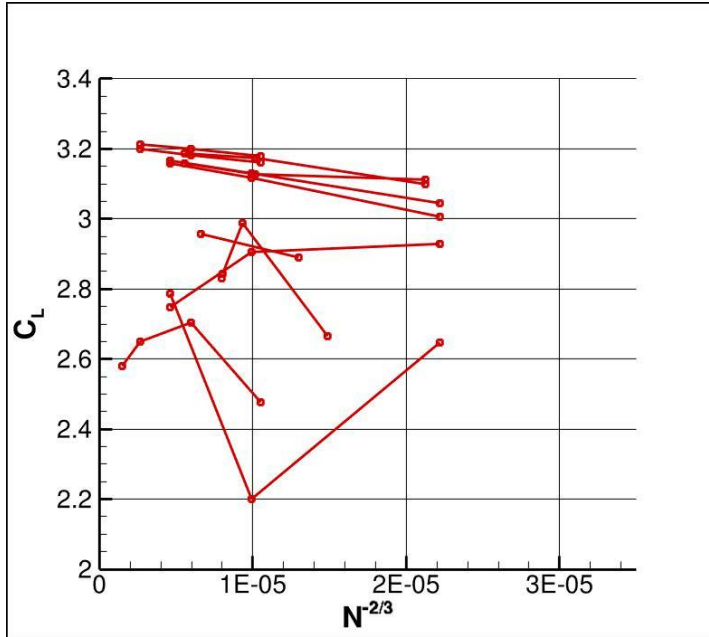

Much more difficult to tell where soln going at higher AoAs

Case 1 Iterative convergence, AoA=7

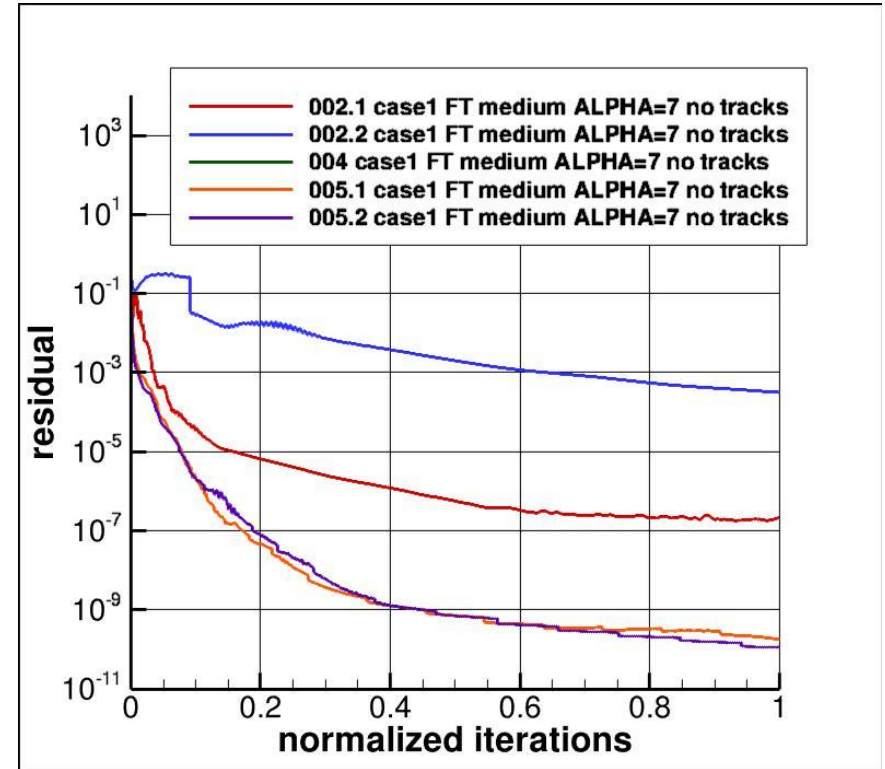
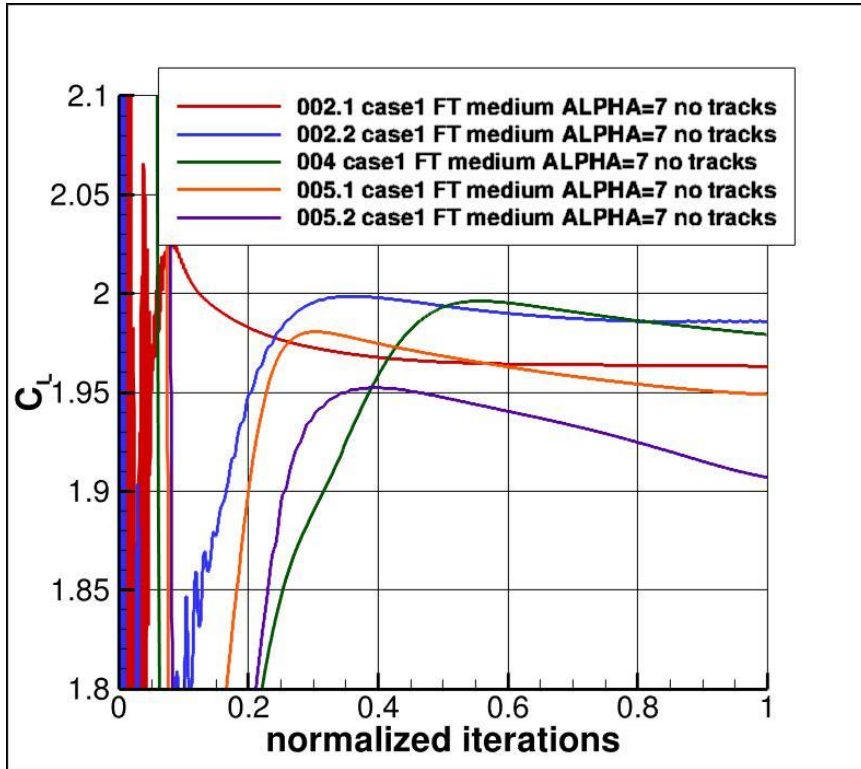

Case 1 Iterative convergence, AoA=7

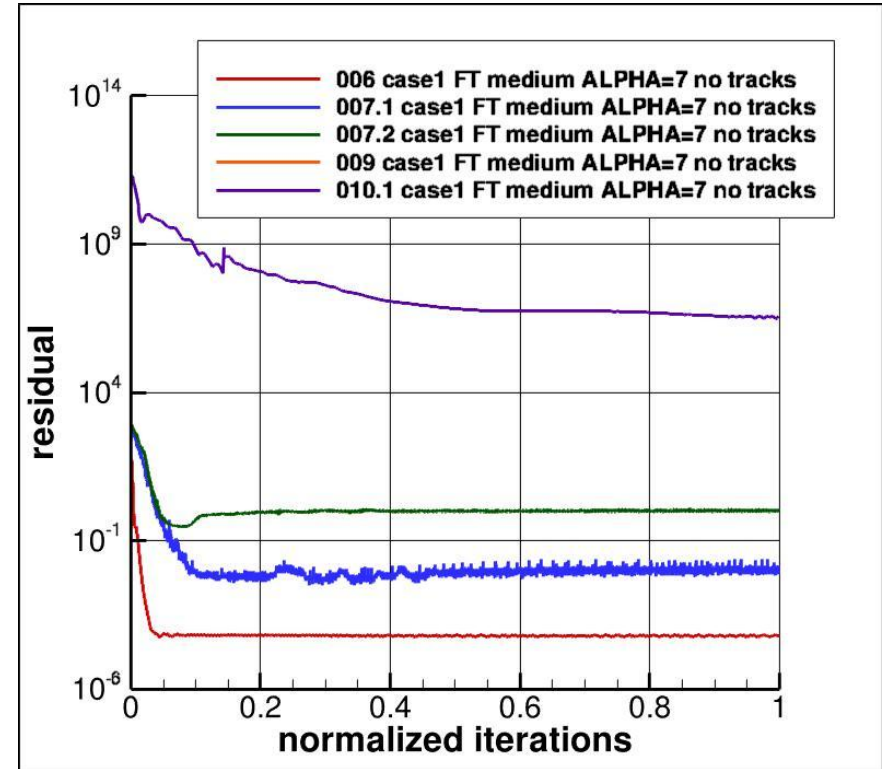
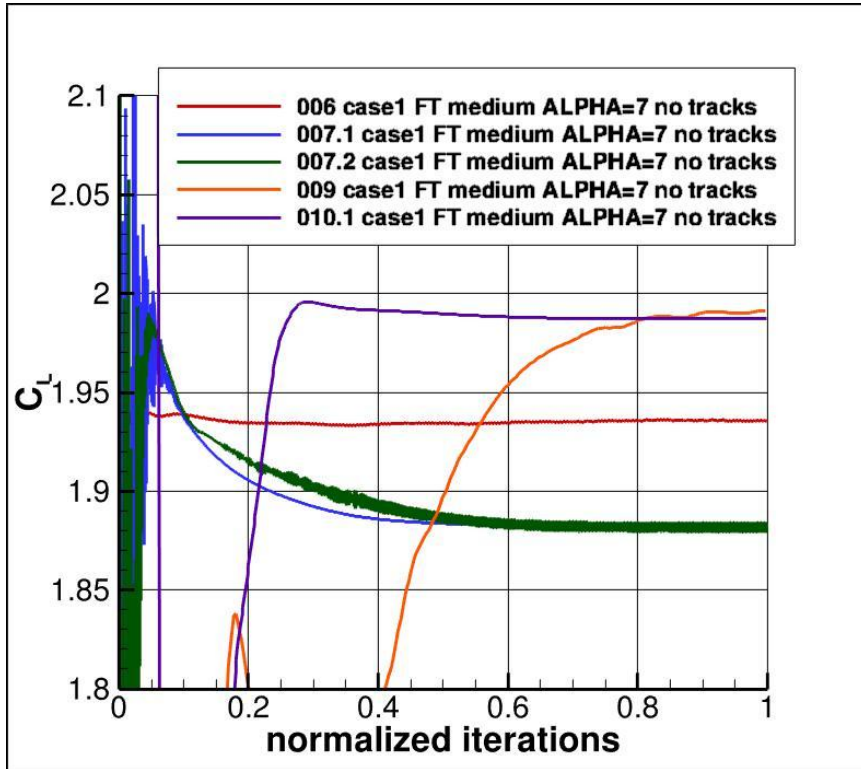

Case 1 Iterative convergence, AoA=7

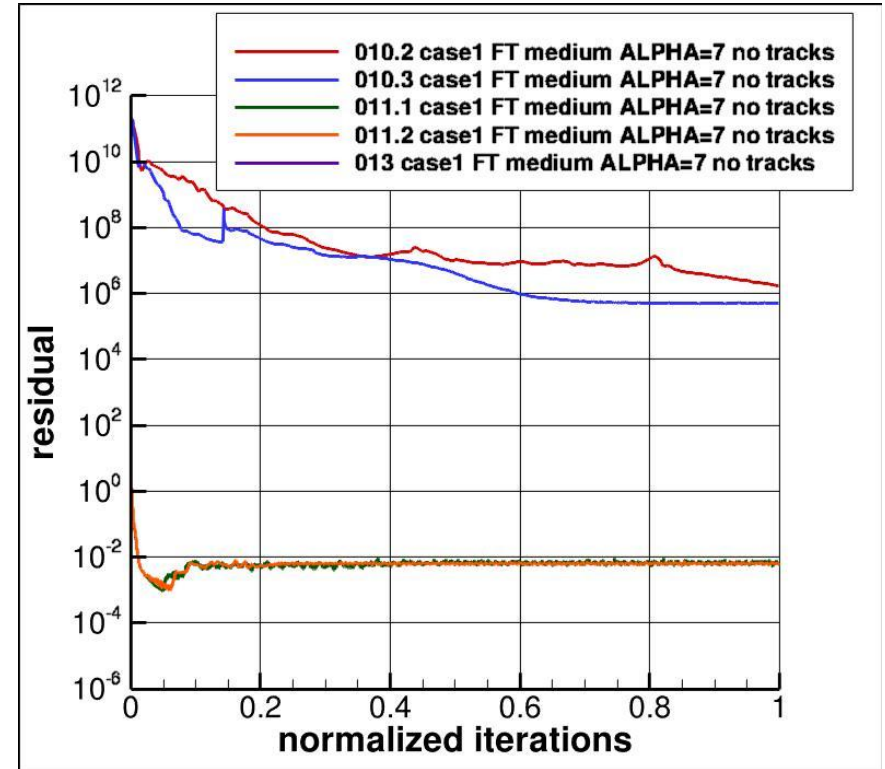
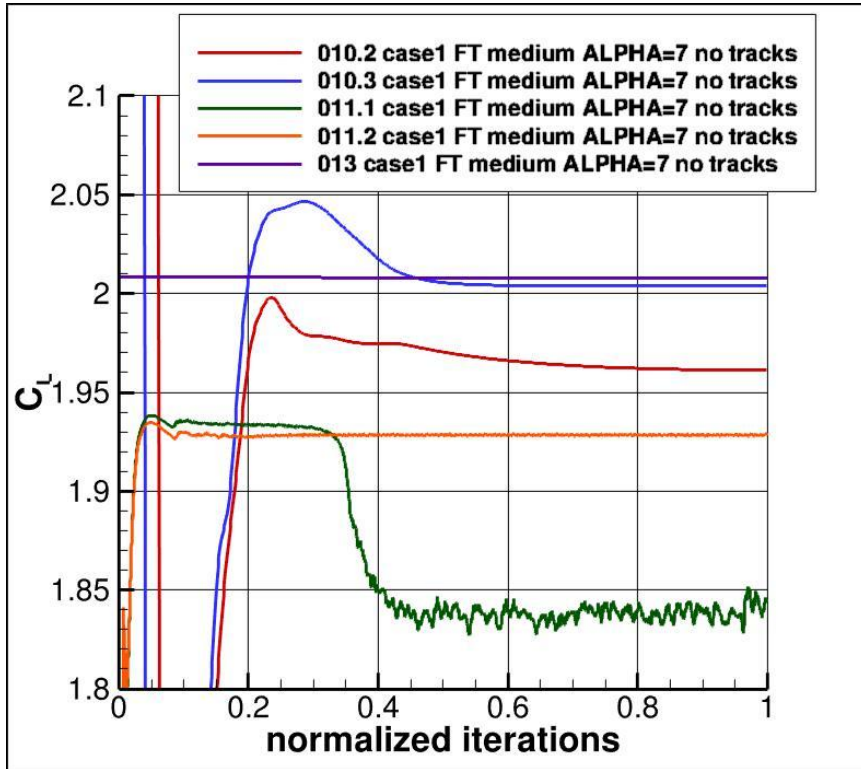

Case 1 Iterative convergence, AoA=7

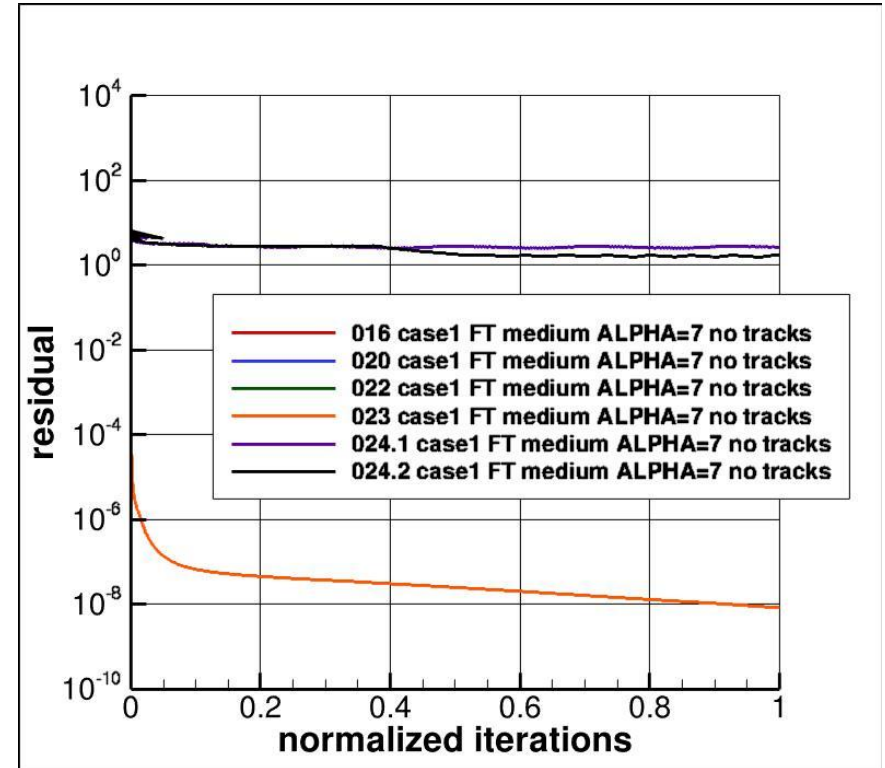
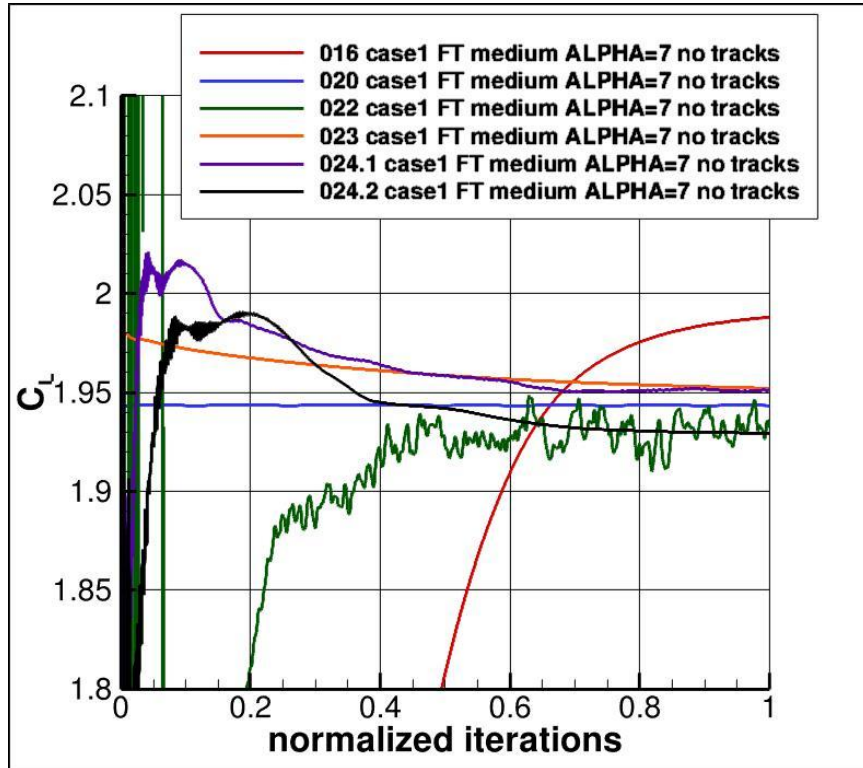

GREEN (022) – time accurate

Case 1 Iterative convergence, AoA=16

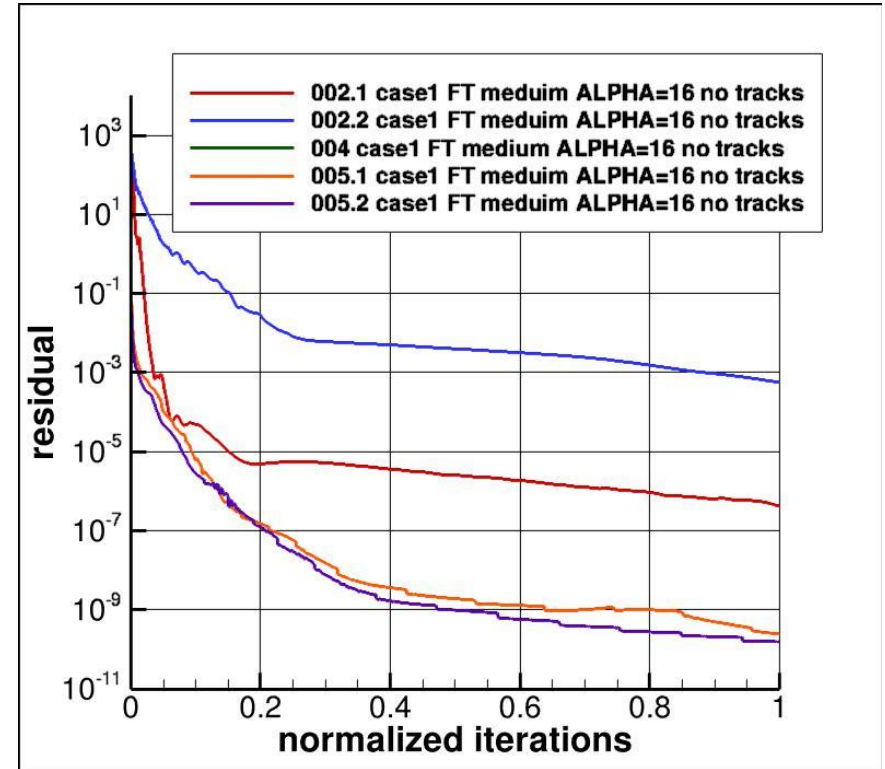
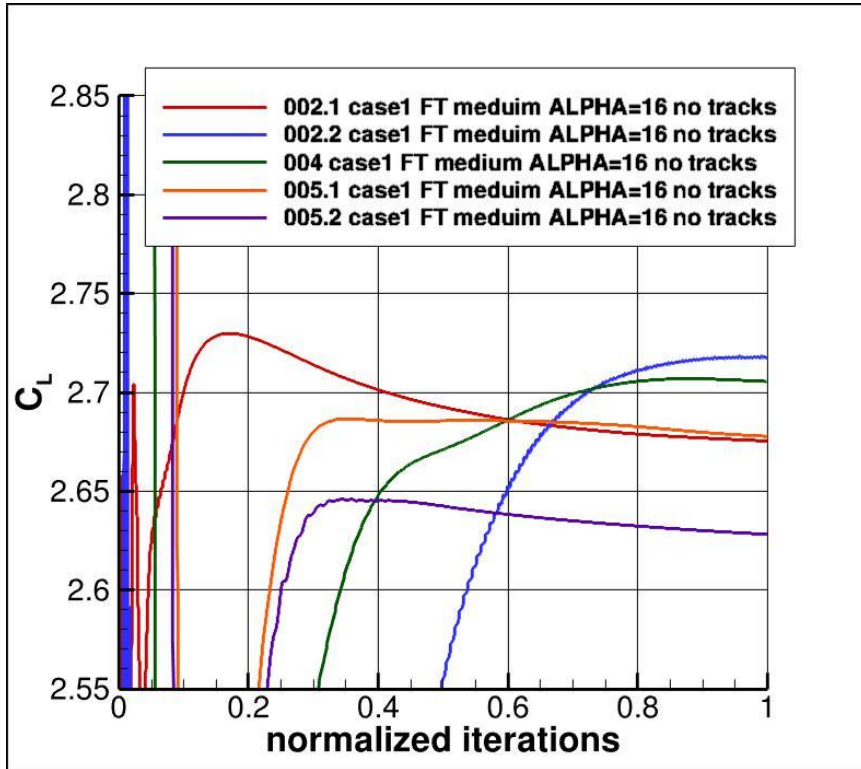

Case 1 Iterative convergence, AoA=16

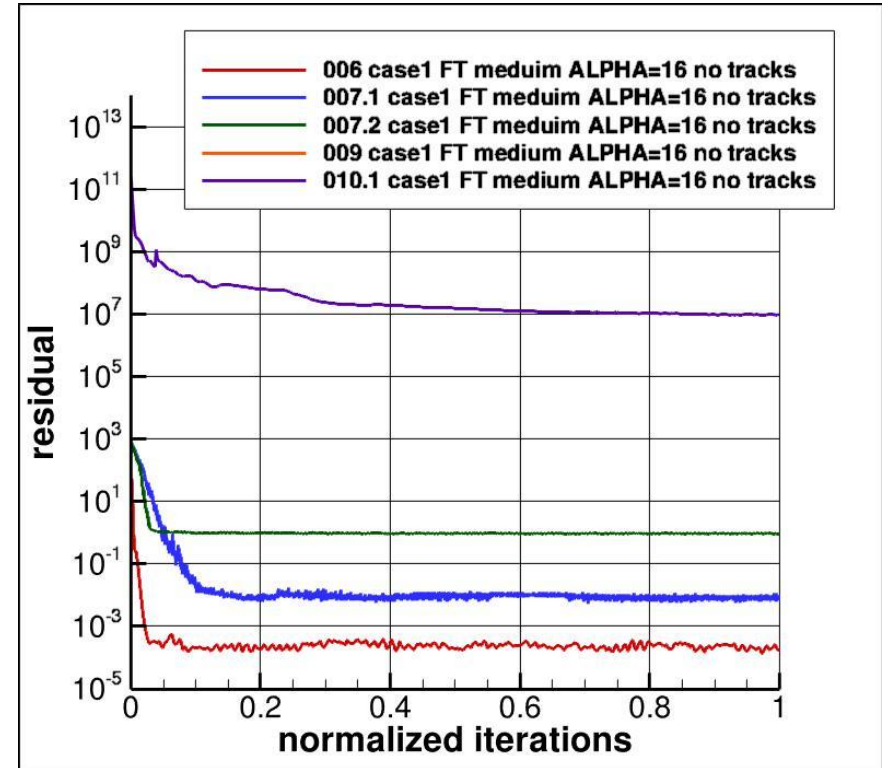
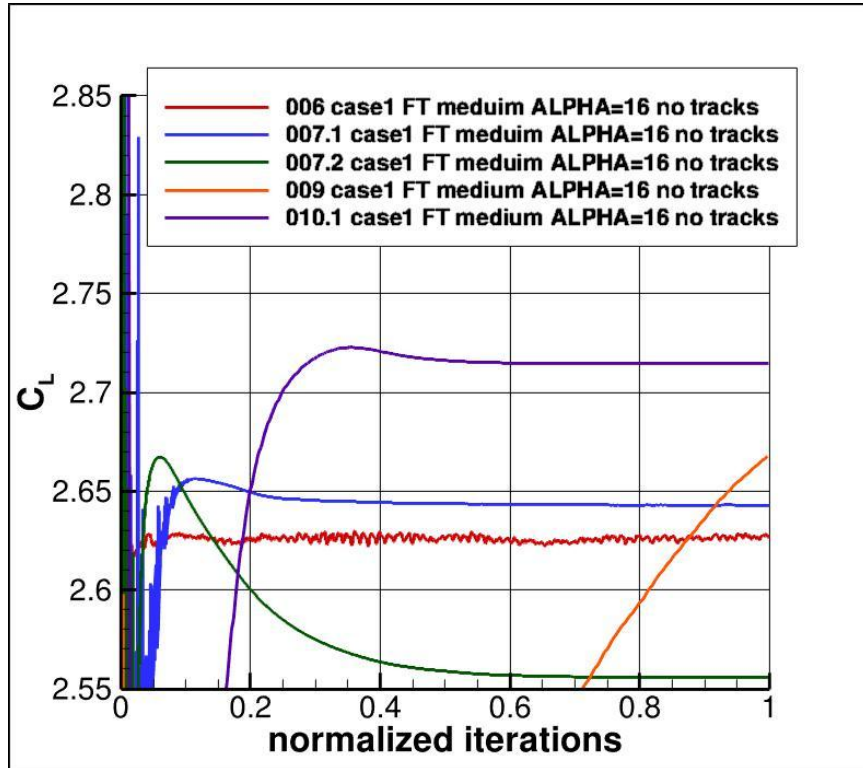

Case 1 Iterative convergence, AoA=16

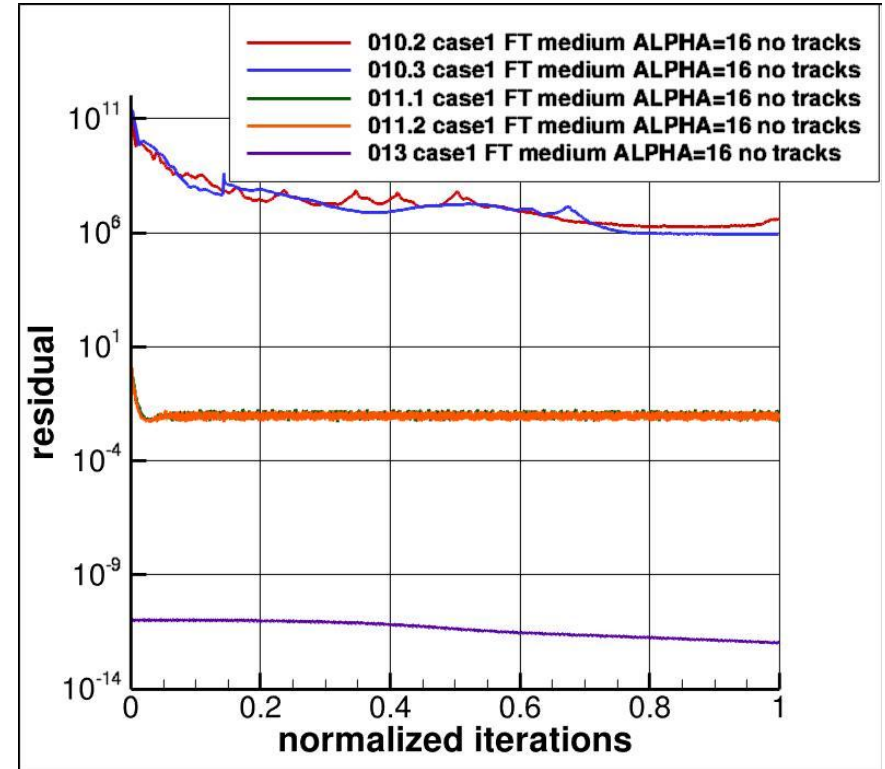
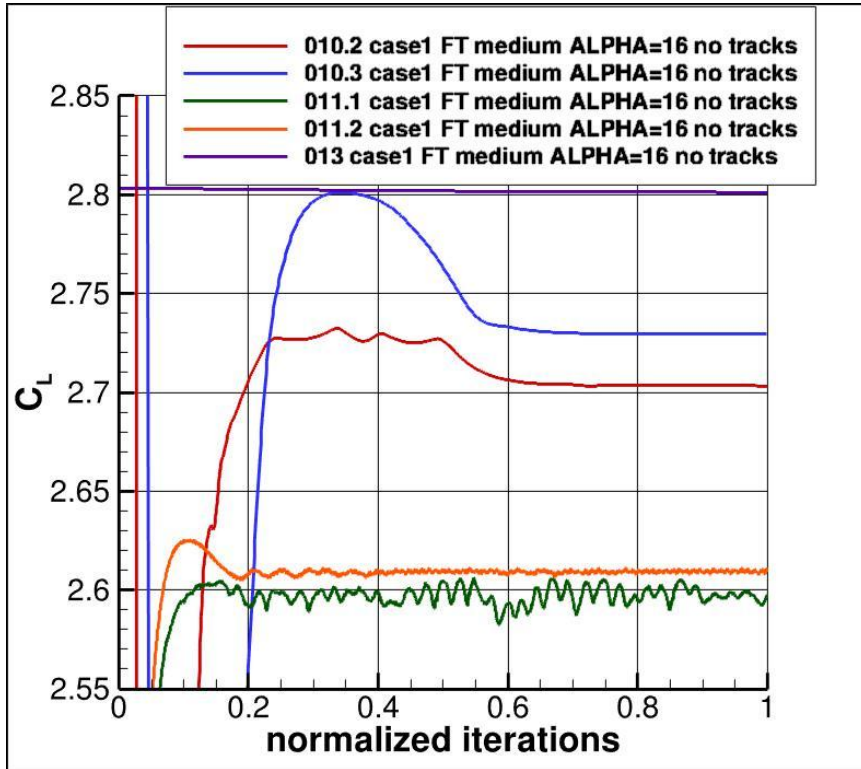

Case 1 Iterative convergence, AoA=16

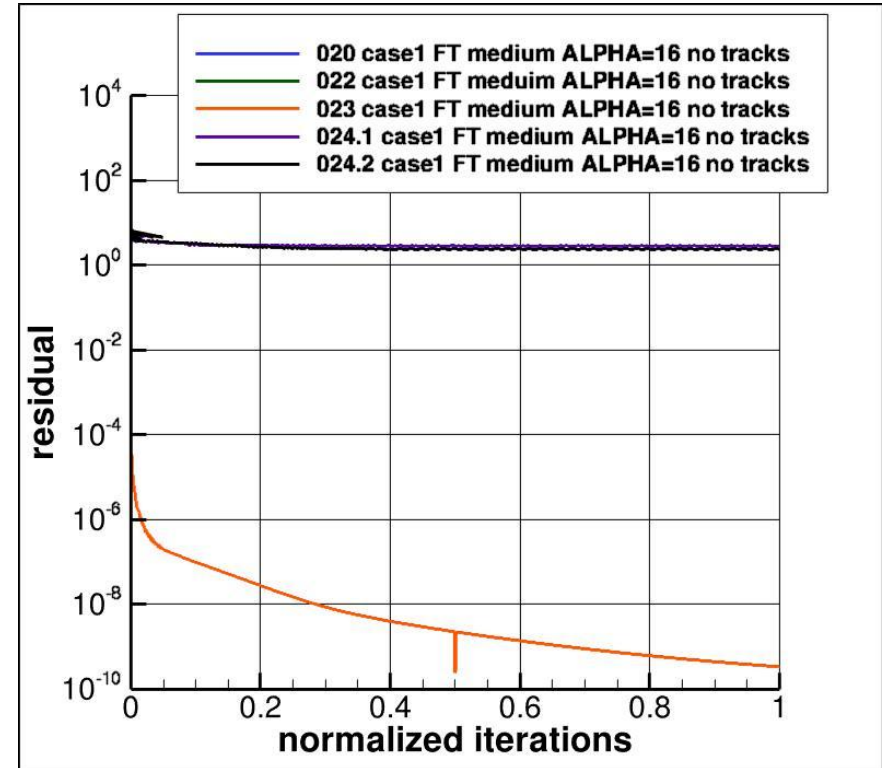
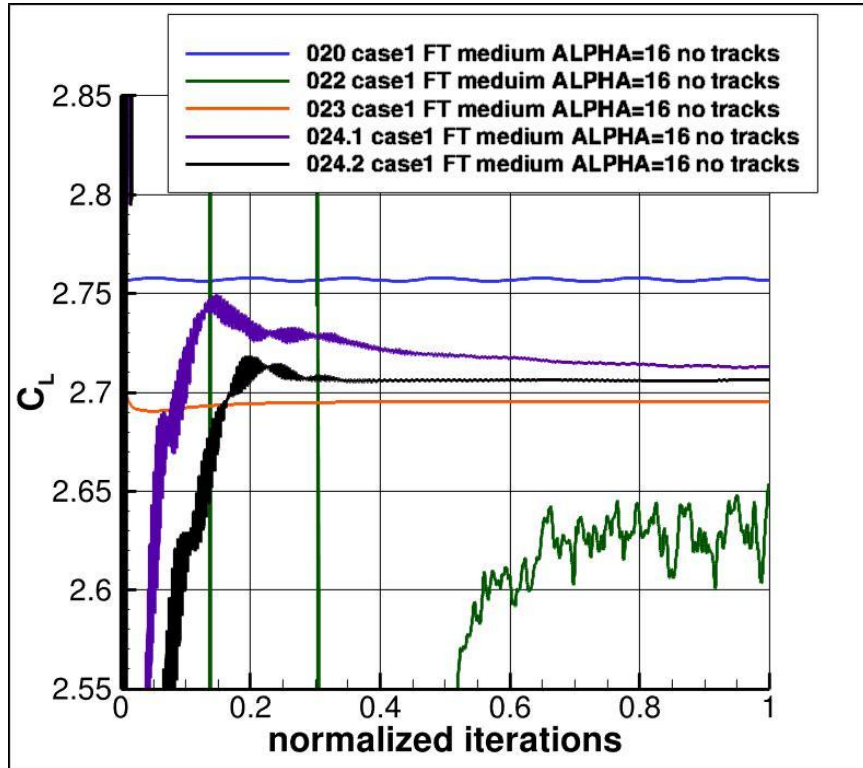

GREEN (022) – time accurate

Case 1 Iterative convergence

- Roughly 20-30% of the results for Case 1 may not have been converged sufficiently
 - Both AoA=7 and 16
 - Other AoA's not checked yet
- About half of participants' residuals “hang”

Same code, same model?

AoA=7

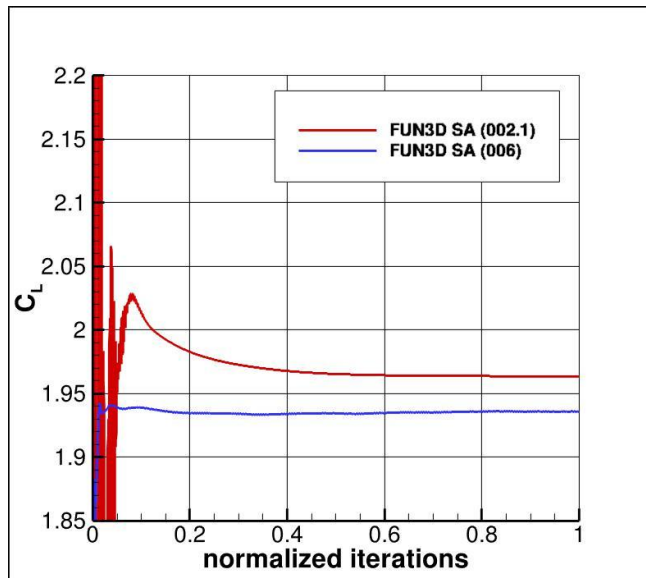

AoA=16

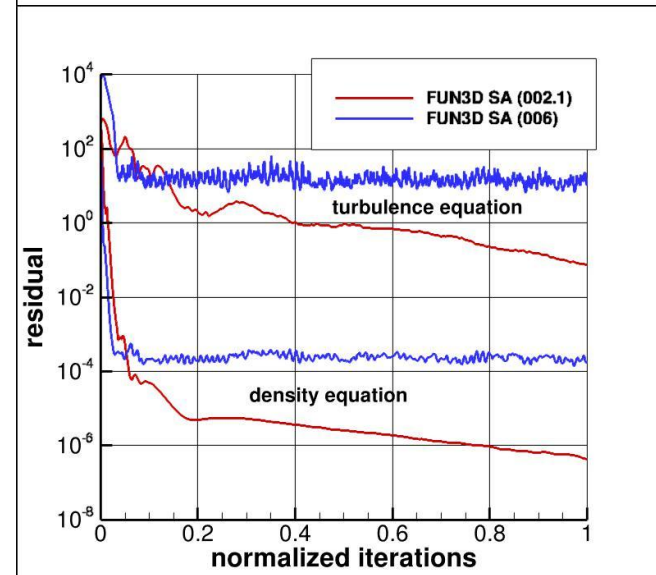
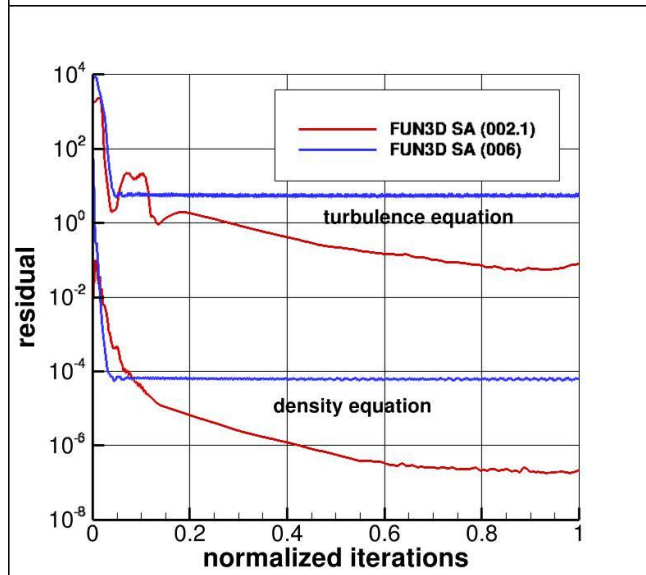
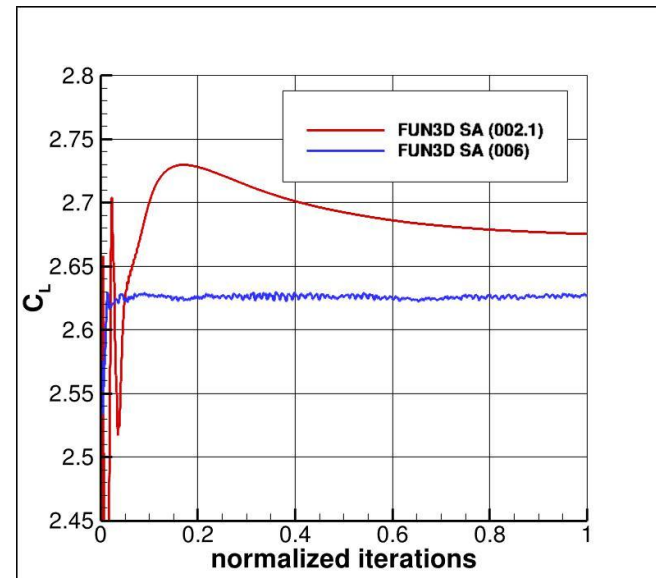

Case 1 Velocity, AoA=7, 1B1

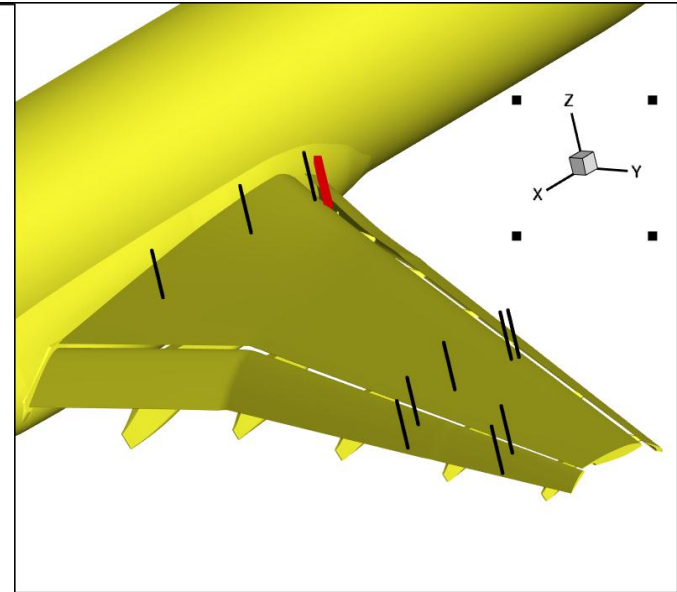
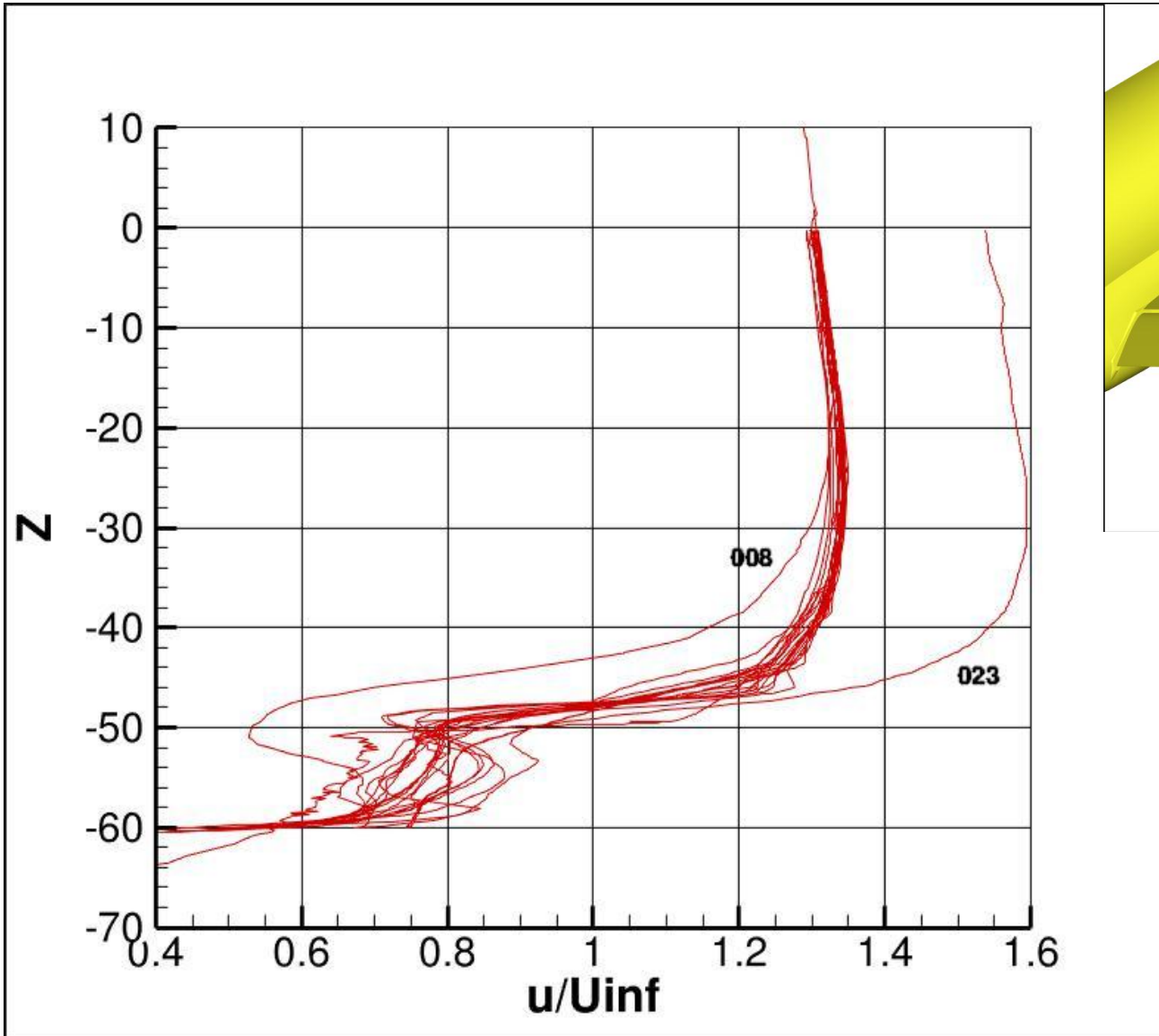

Case 1 Velocity, AoA=7, 1B2

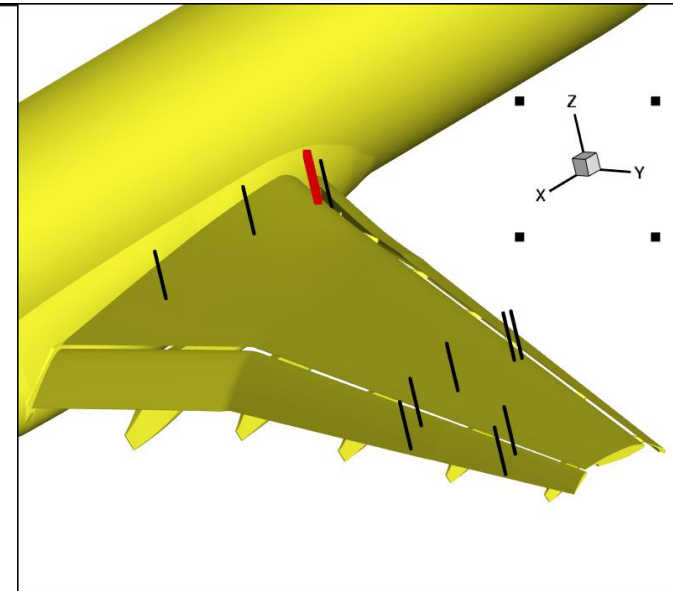
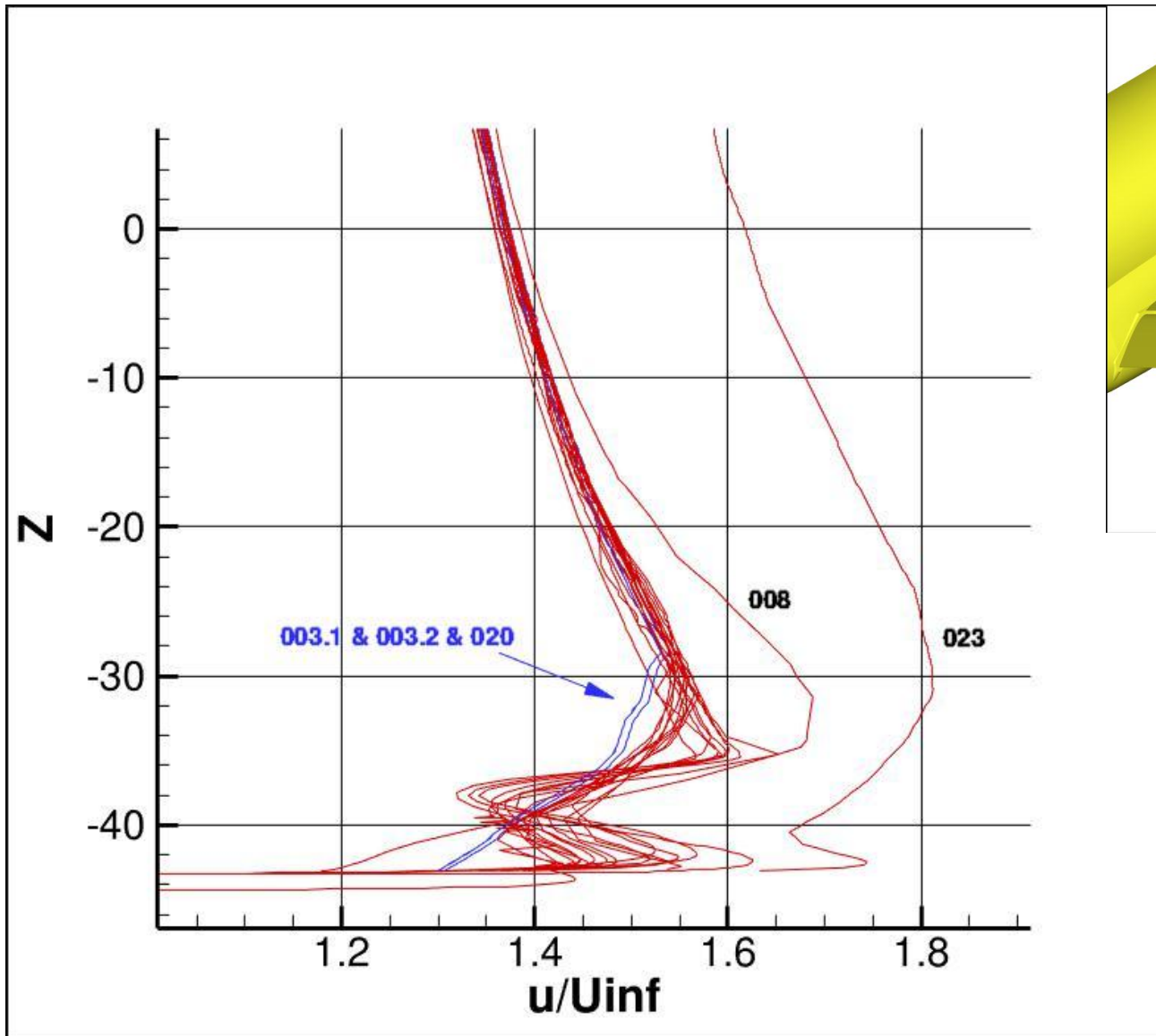

Case 1 Velocity, AoA=7, 1C1

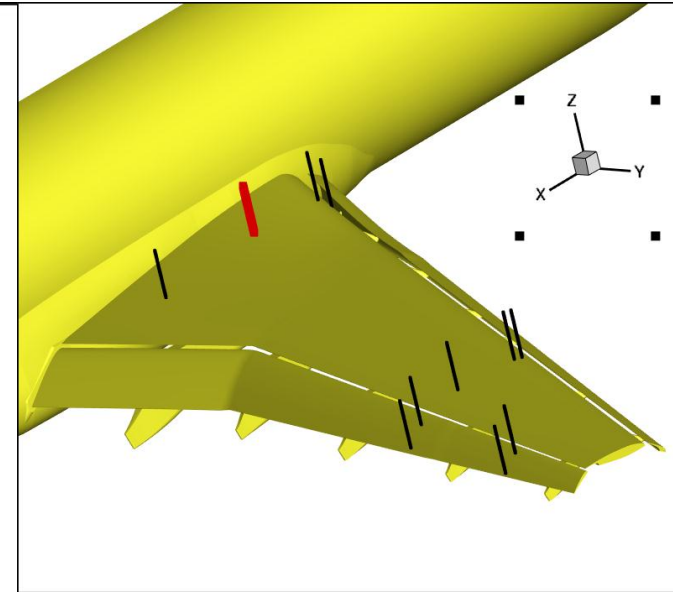
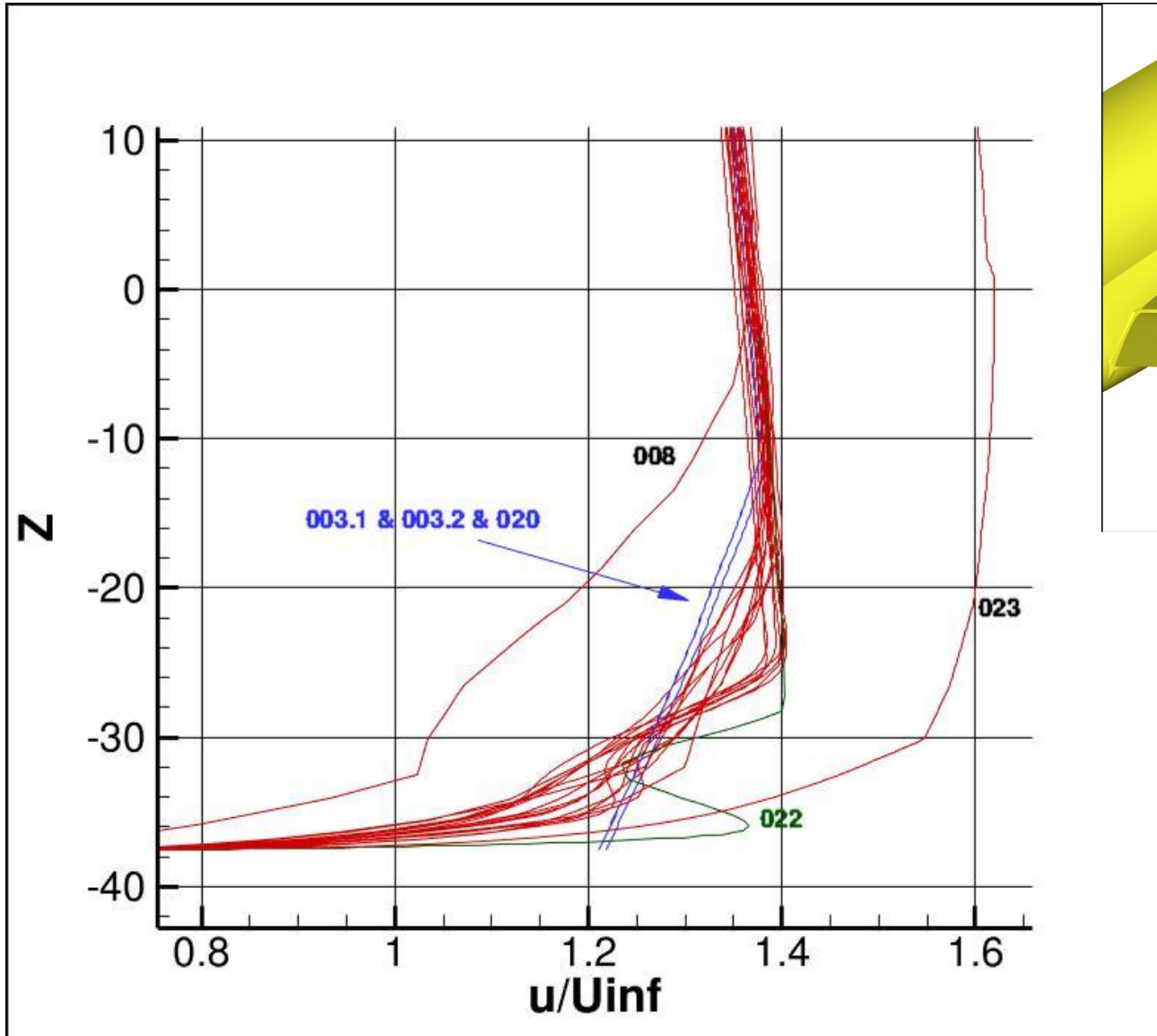

Case 1 Velocity, AoA=7, 1D1

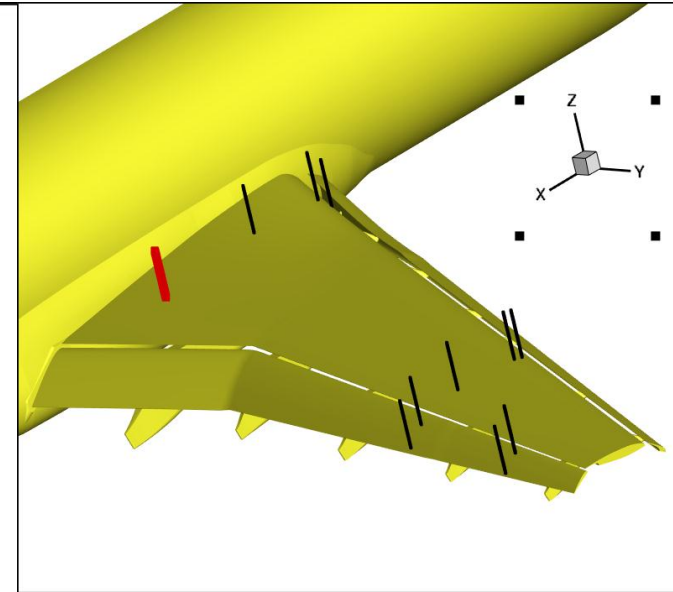
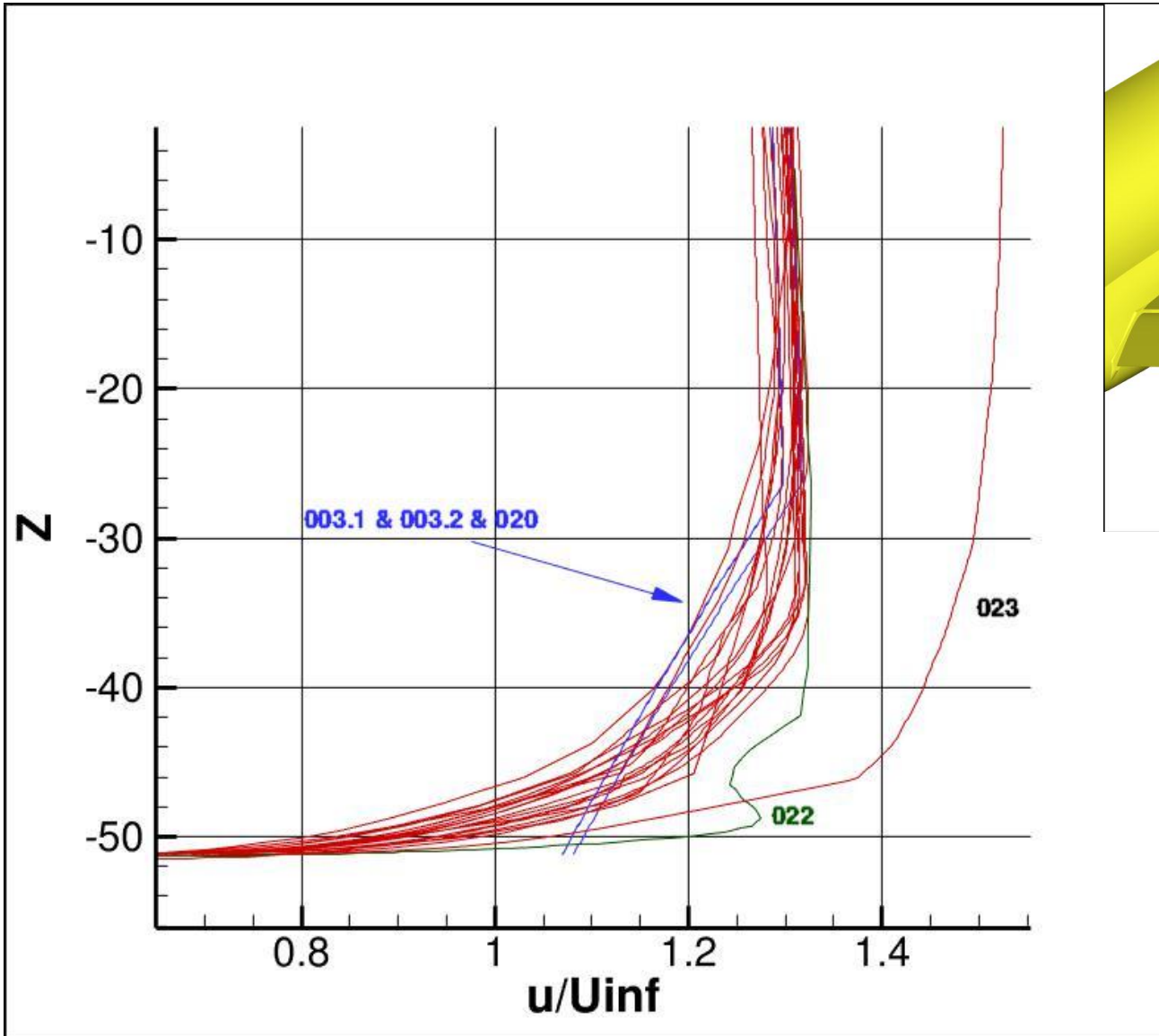

Case 1 Velocity, AoA=7, 2B1

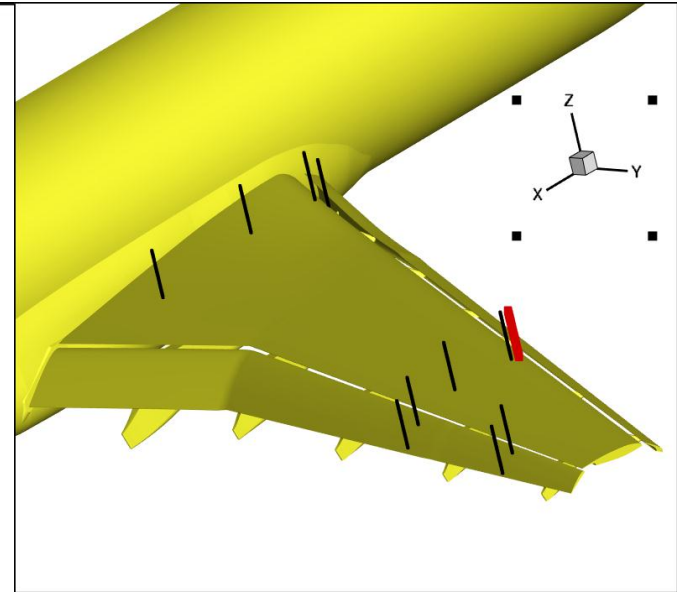
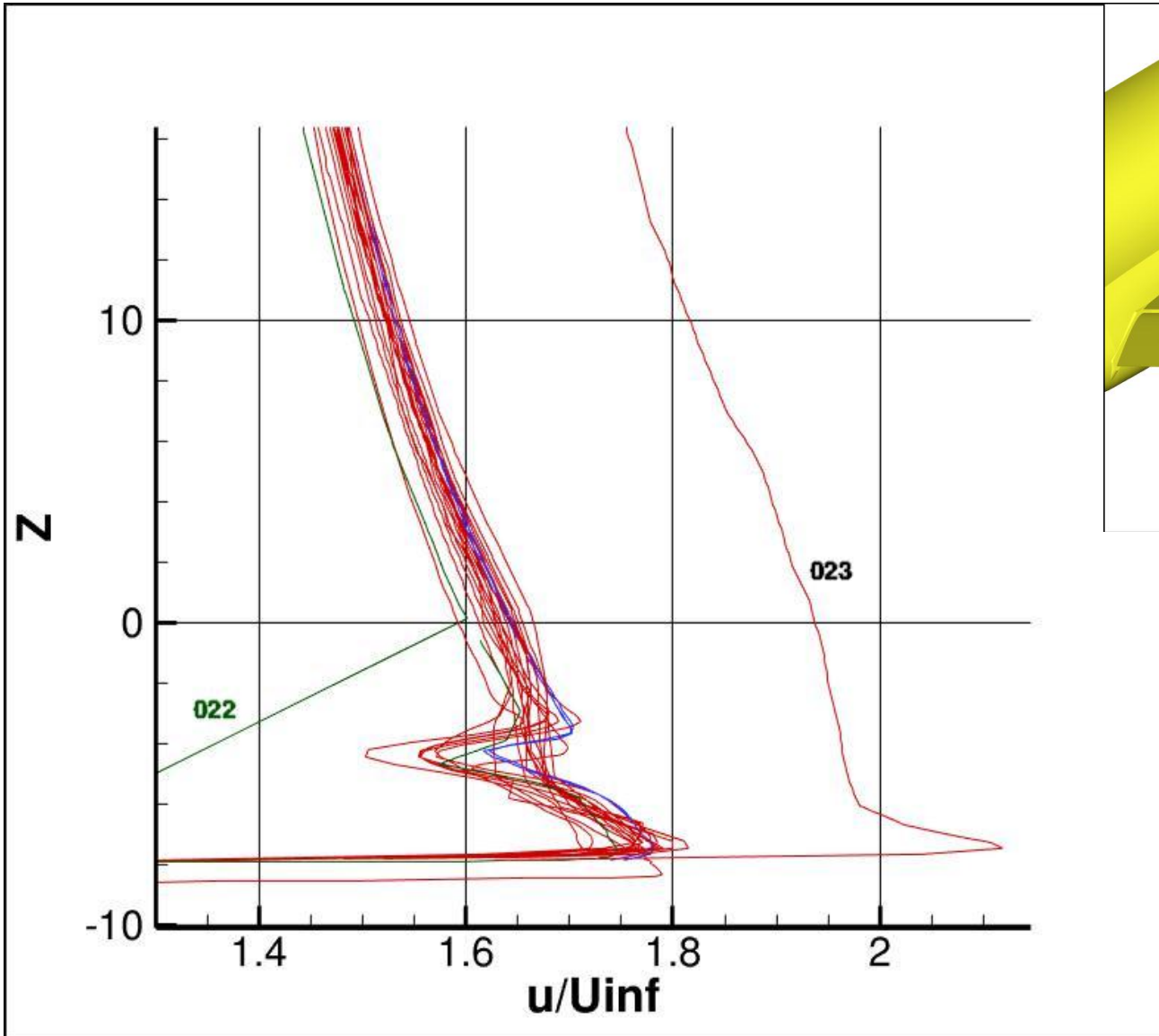

Case 1 Velocity, AoA=7, 2B2

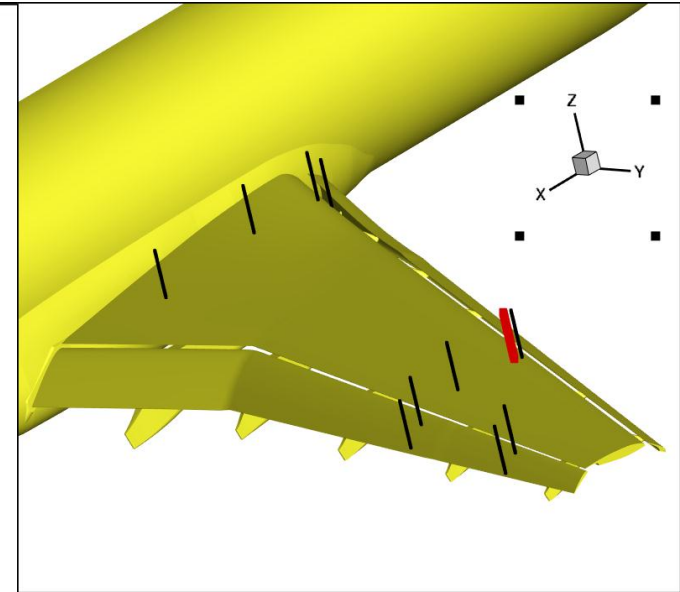
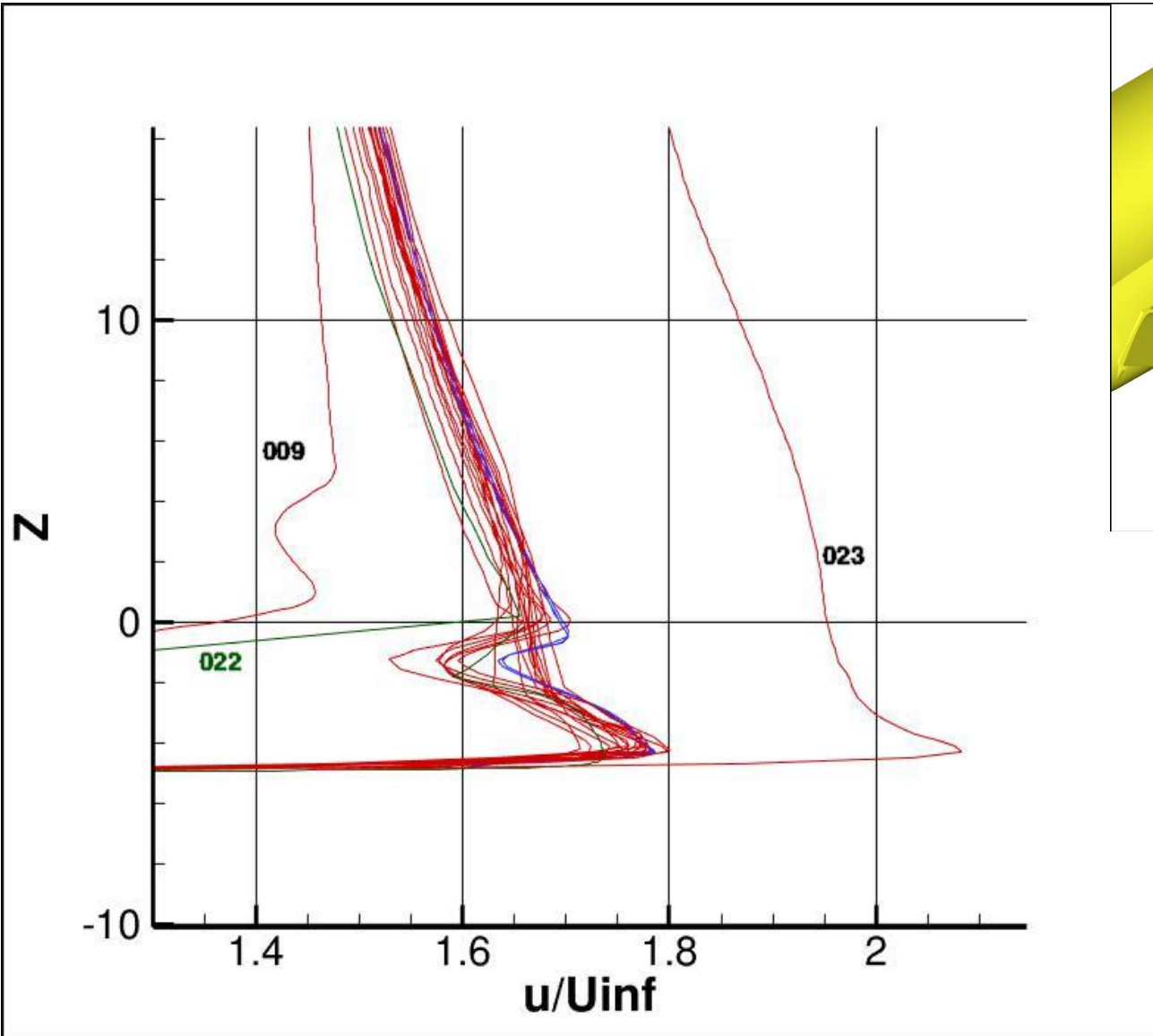

Case 1 Velocity, AoA=7, 2D1

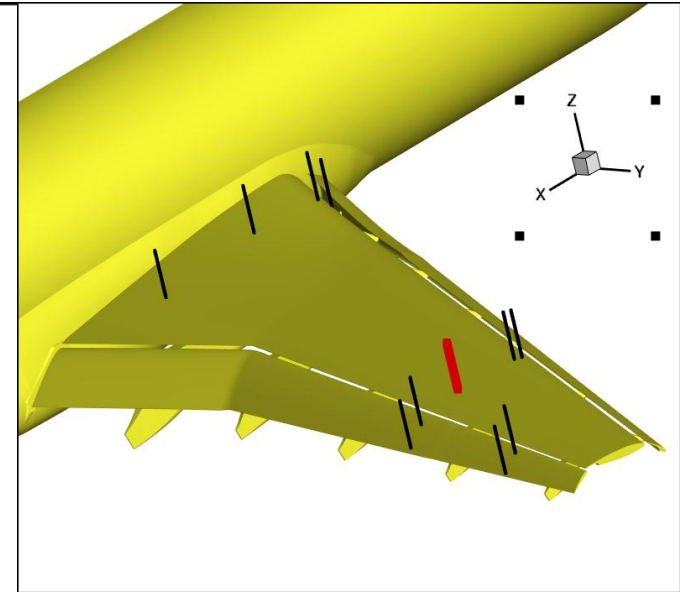
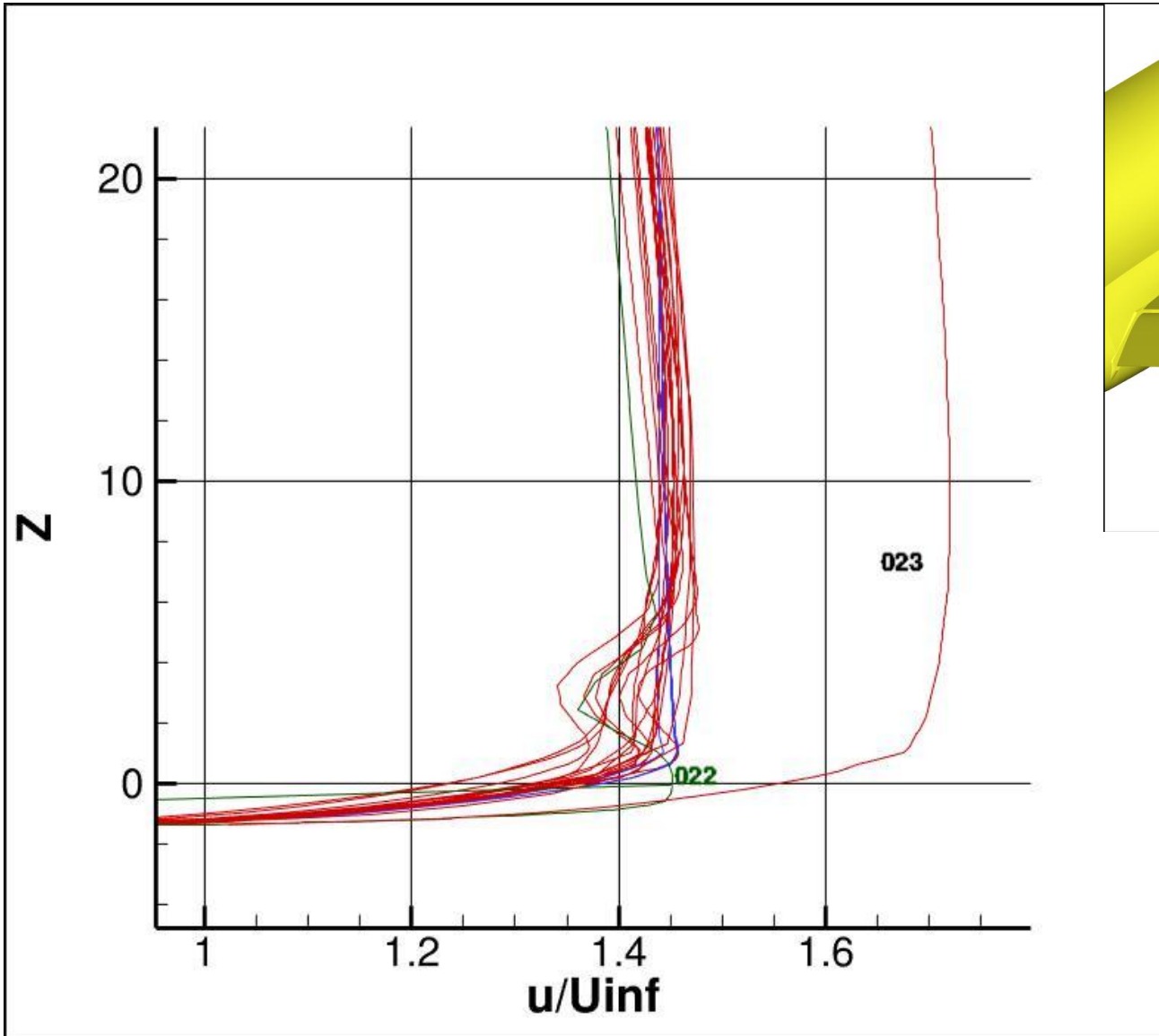

Case 1 Velocity, AoA=7, 2E1

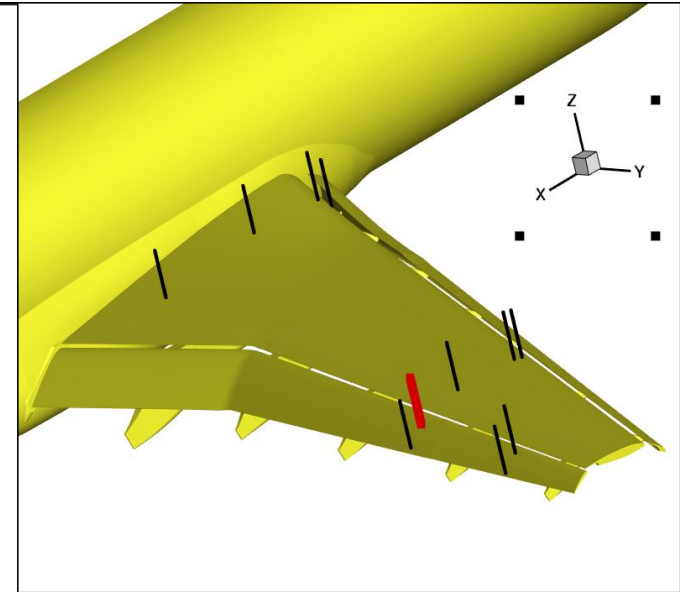
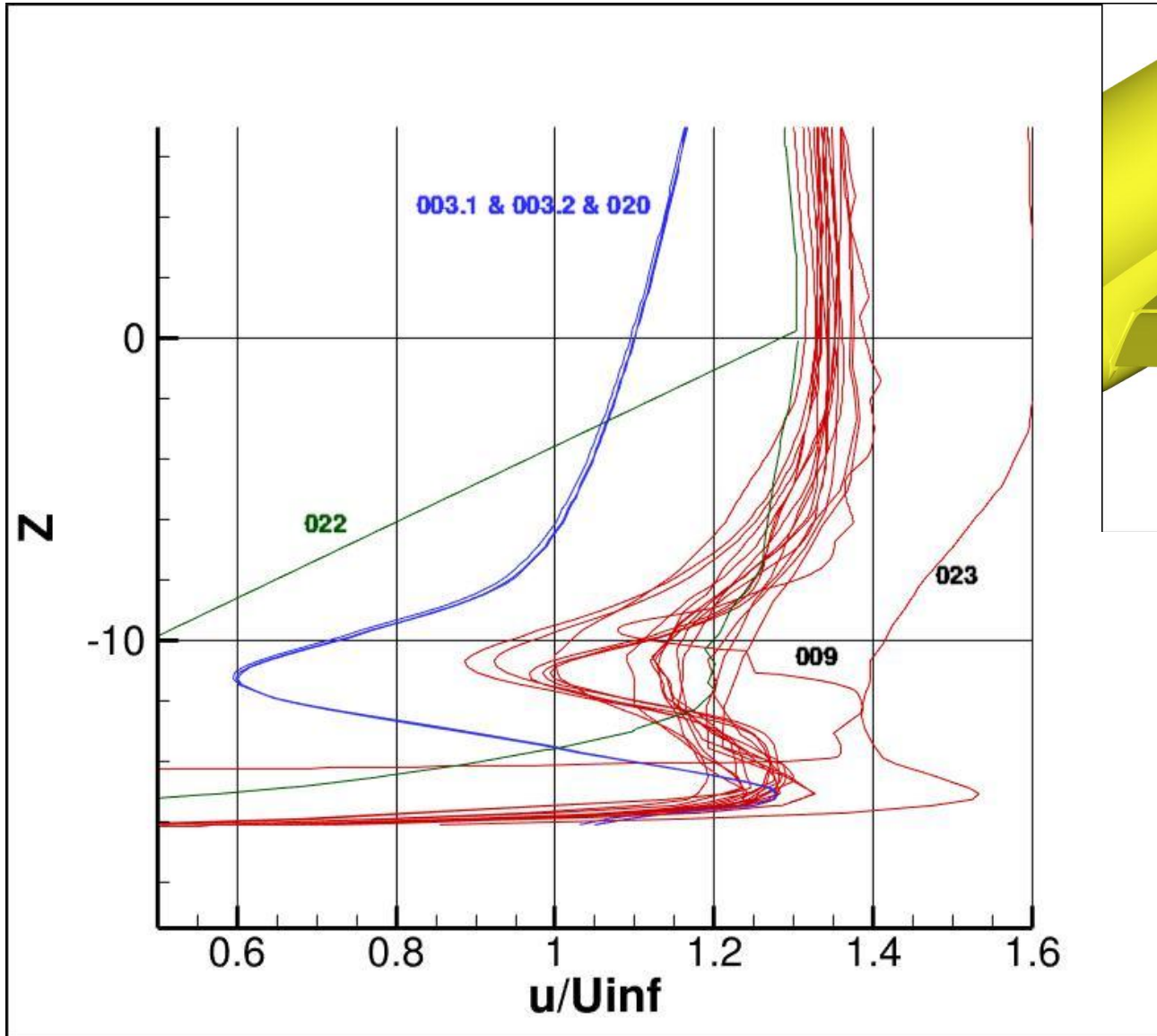

Case 1 Velocity, AoA=7, 2E2

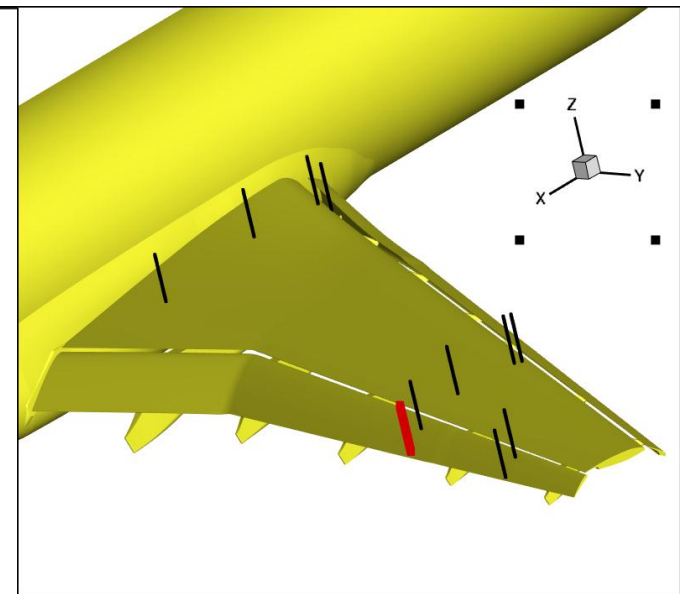
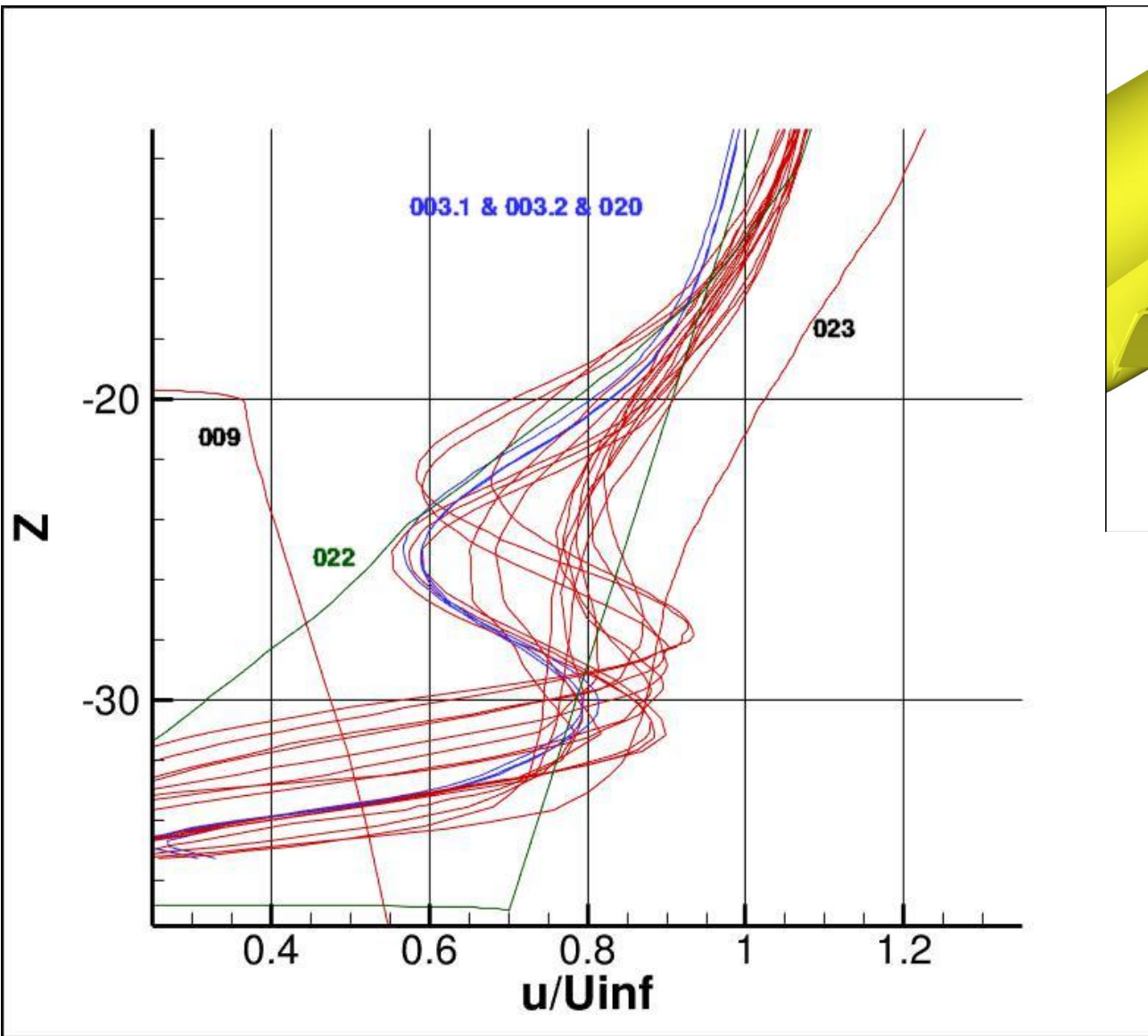

Case 1 Velocity, AoA=7, 3E1

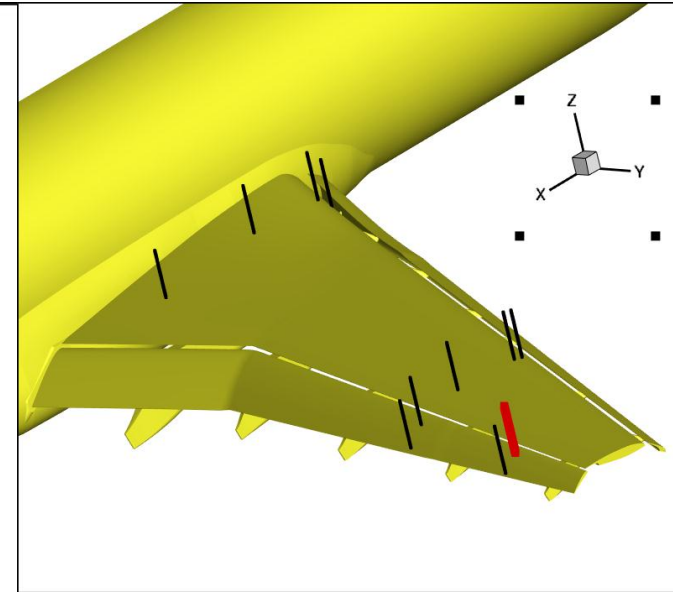
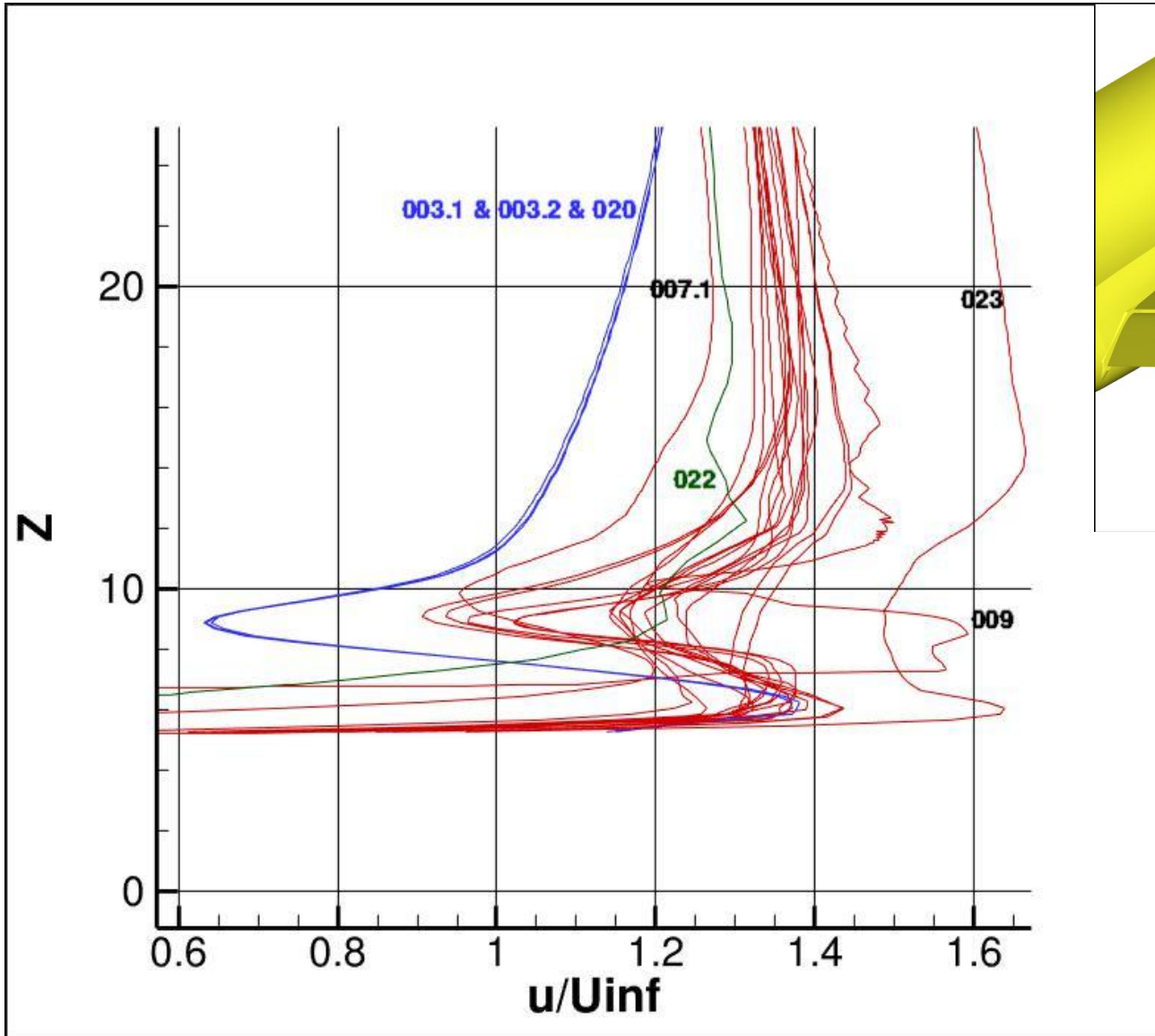

Case 1 Velocity, AoA=7, 3E2

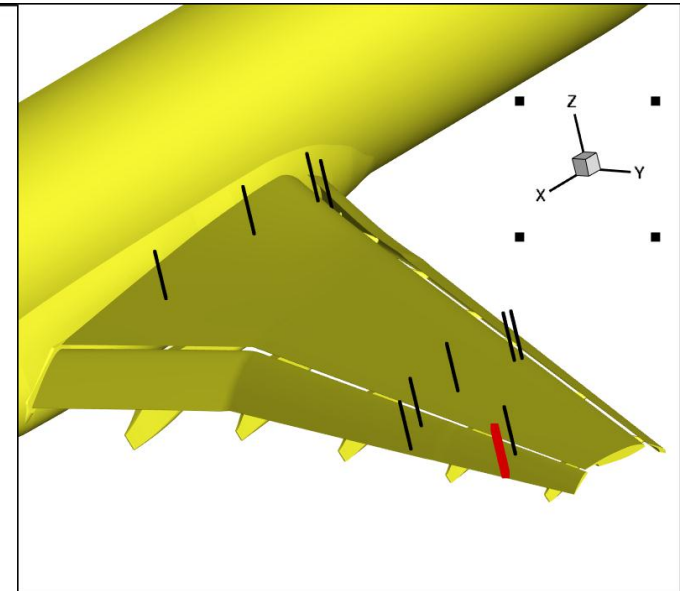
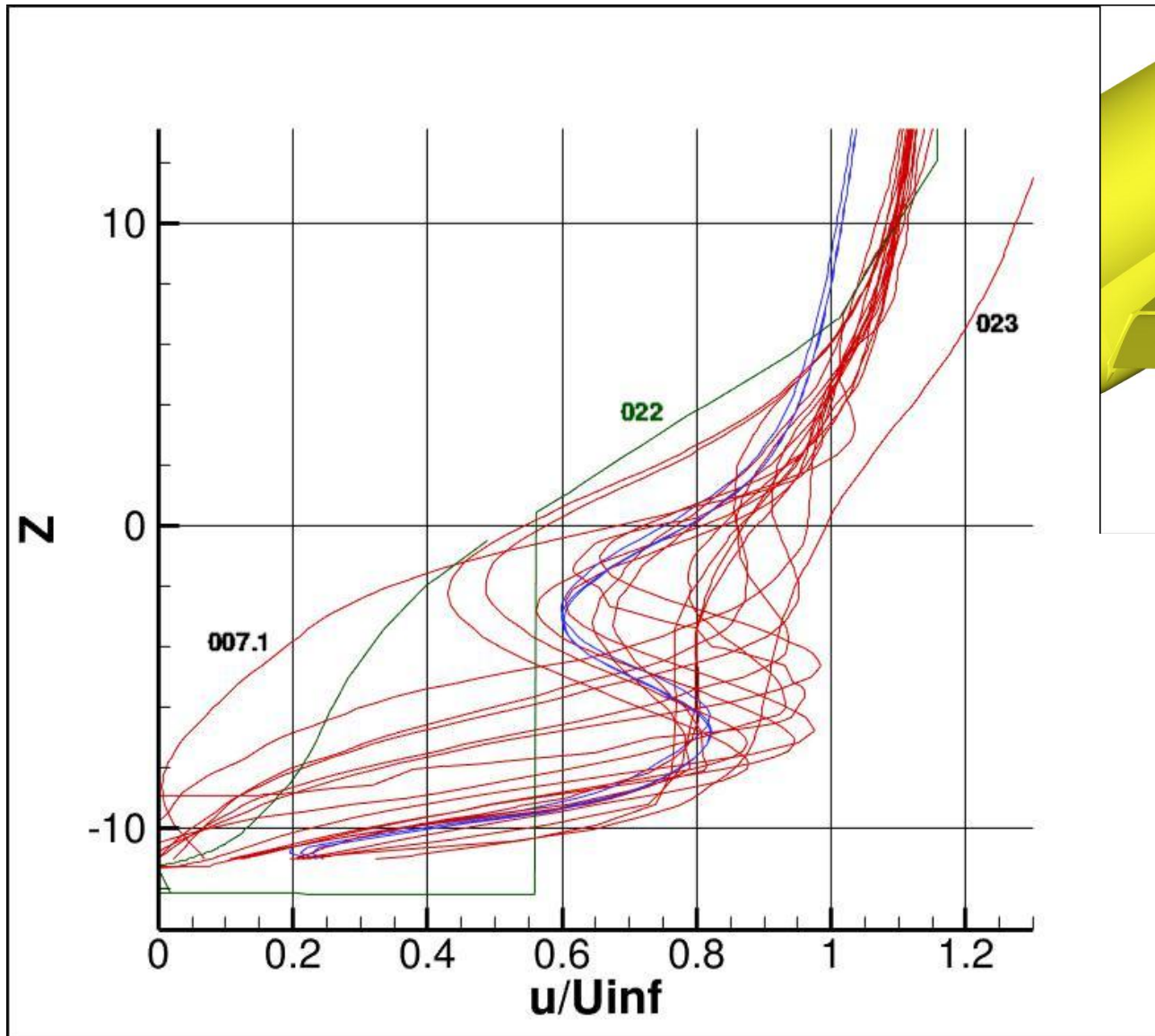

Grid type effect on velocity, AoA=7, 2D1

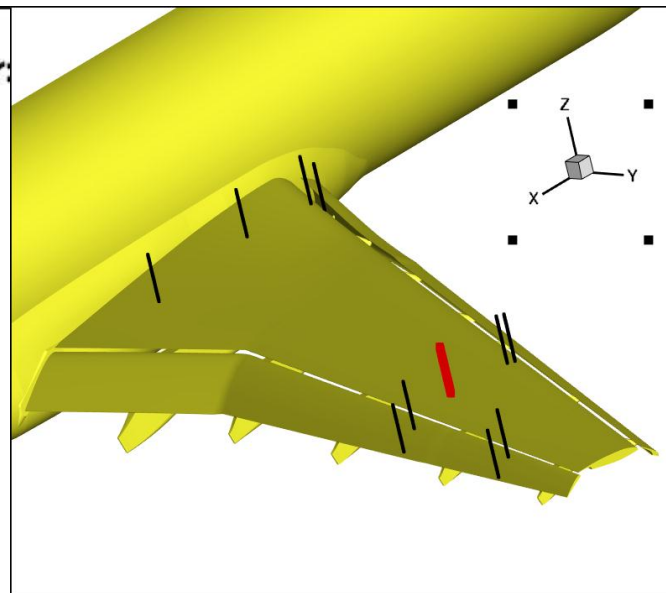
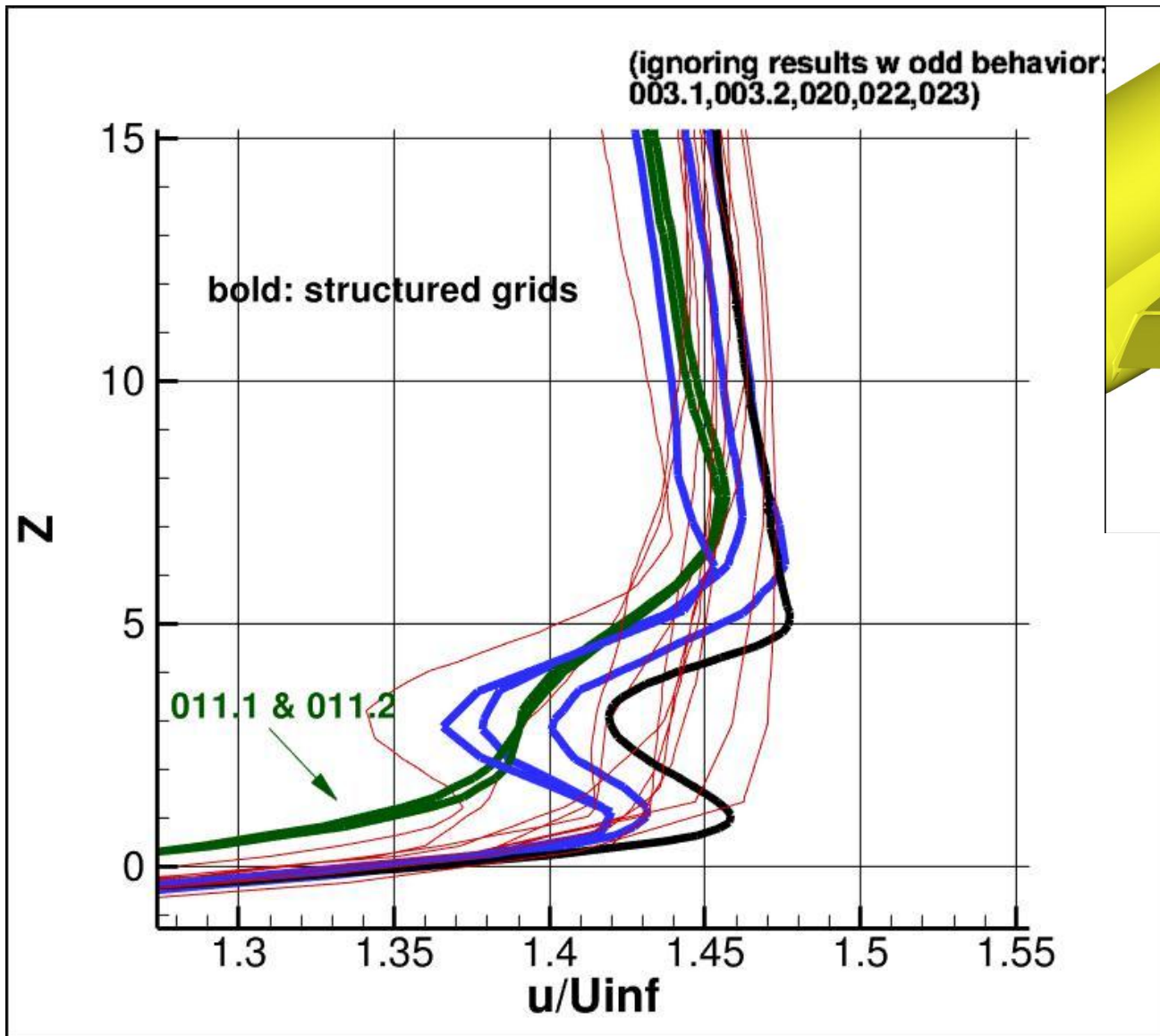

Grid type effect on velocity, AoA=7, 2D1

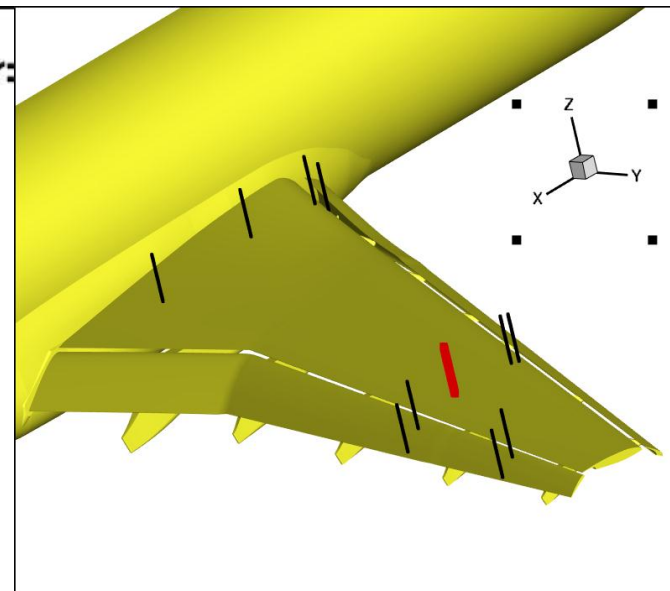
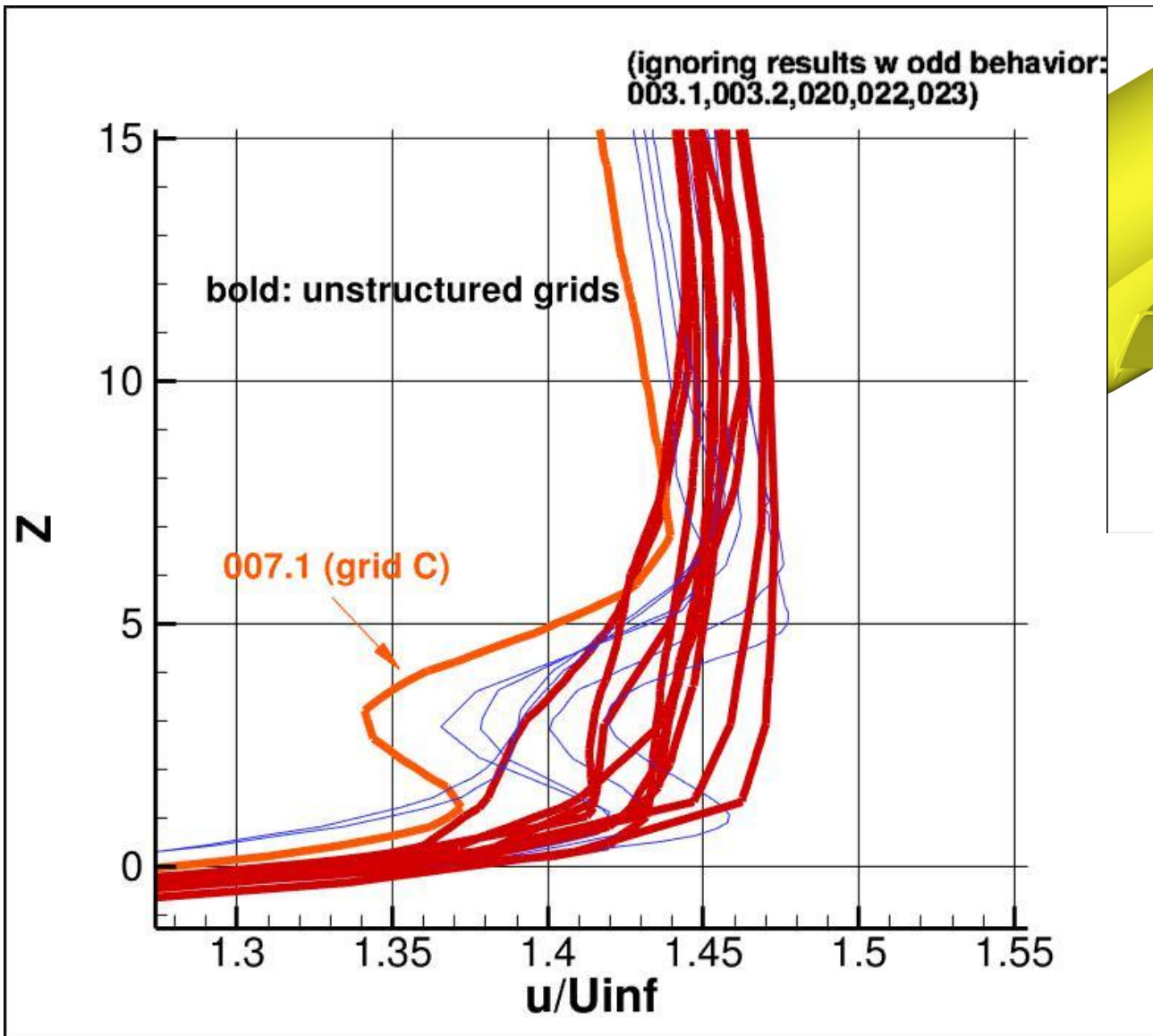

Grid type effect on velocity, AoA=7, 3E1

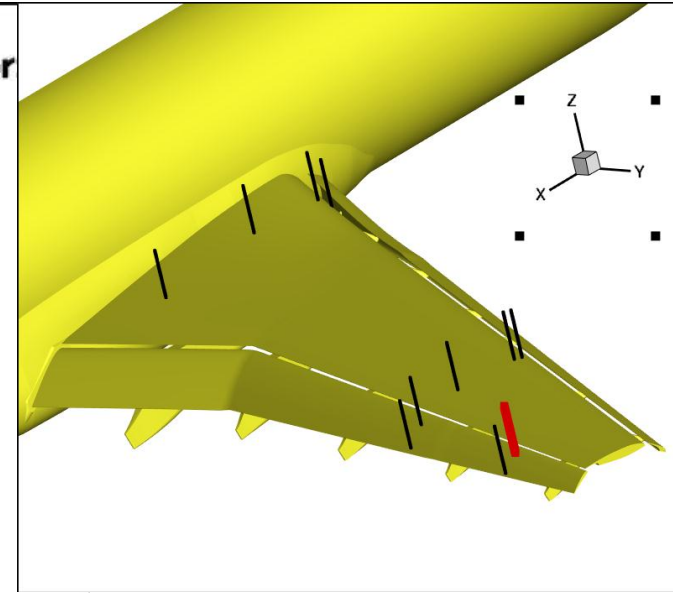
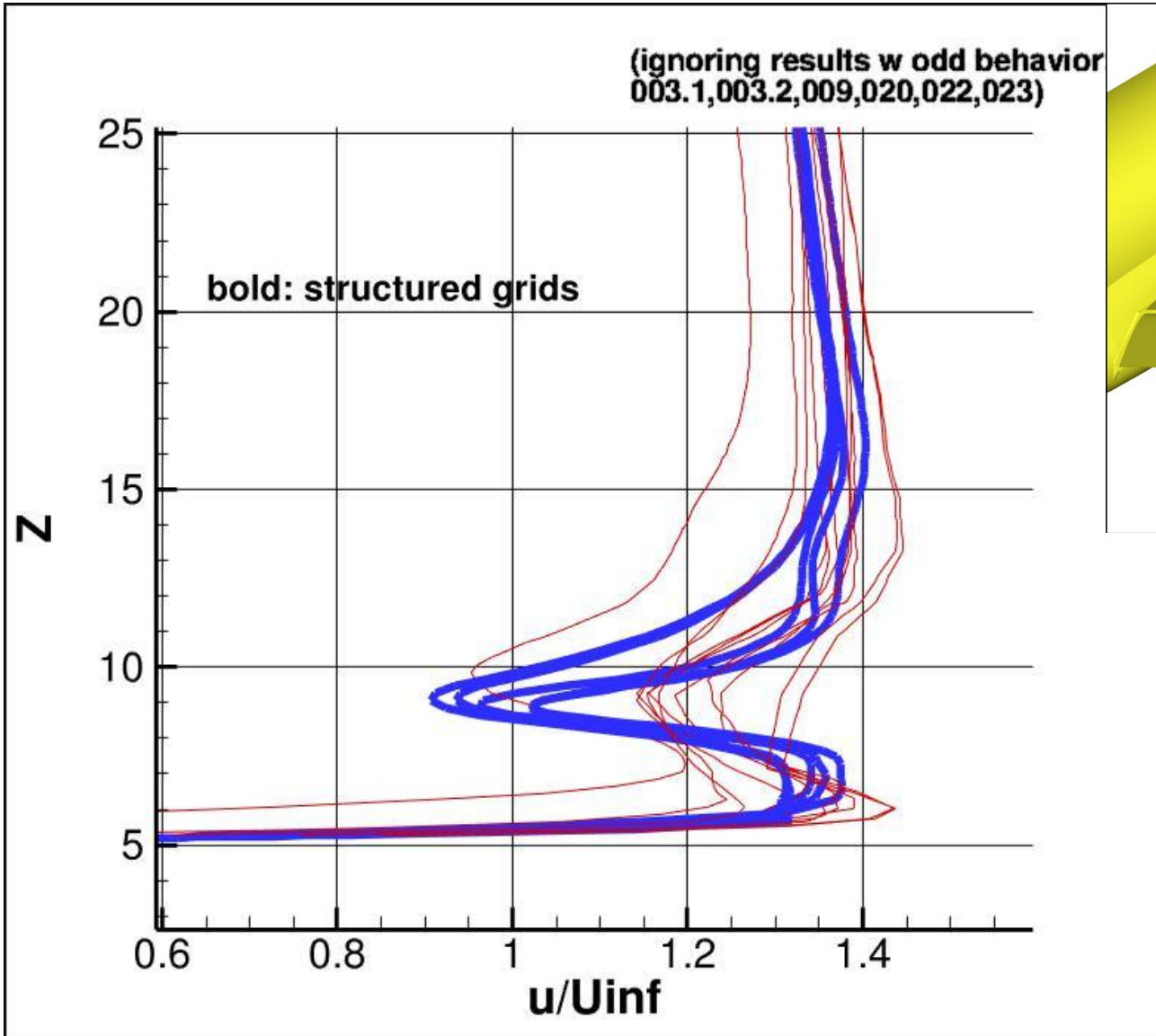

Grid type effect on velocity, AoA=7, 3E1

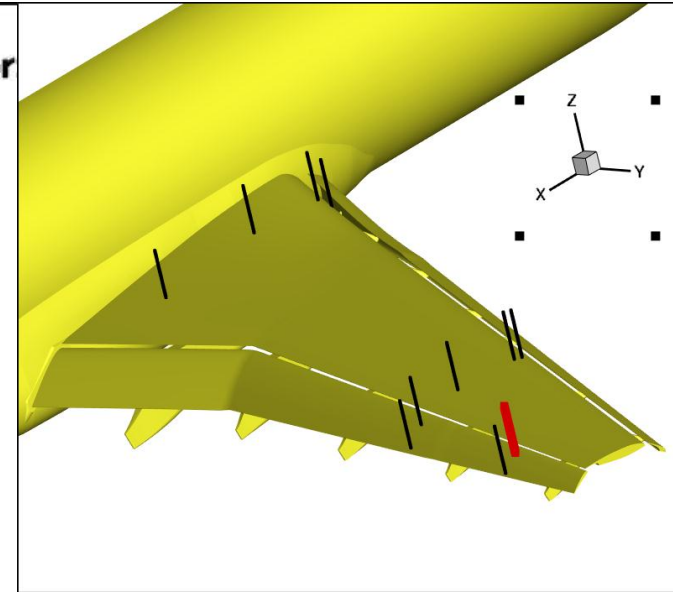
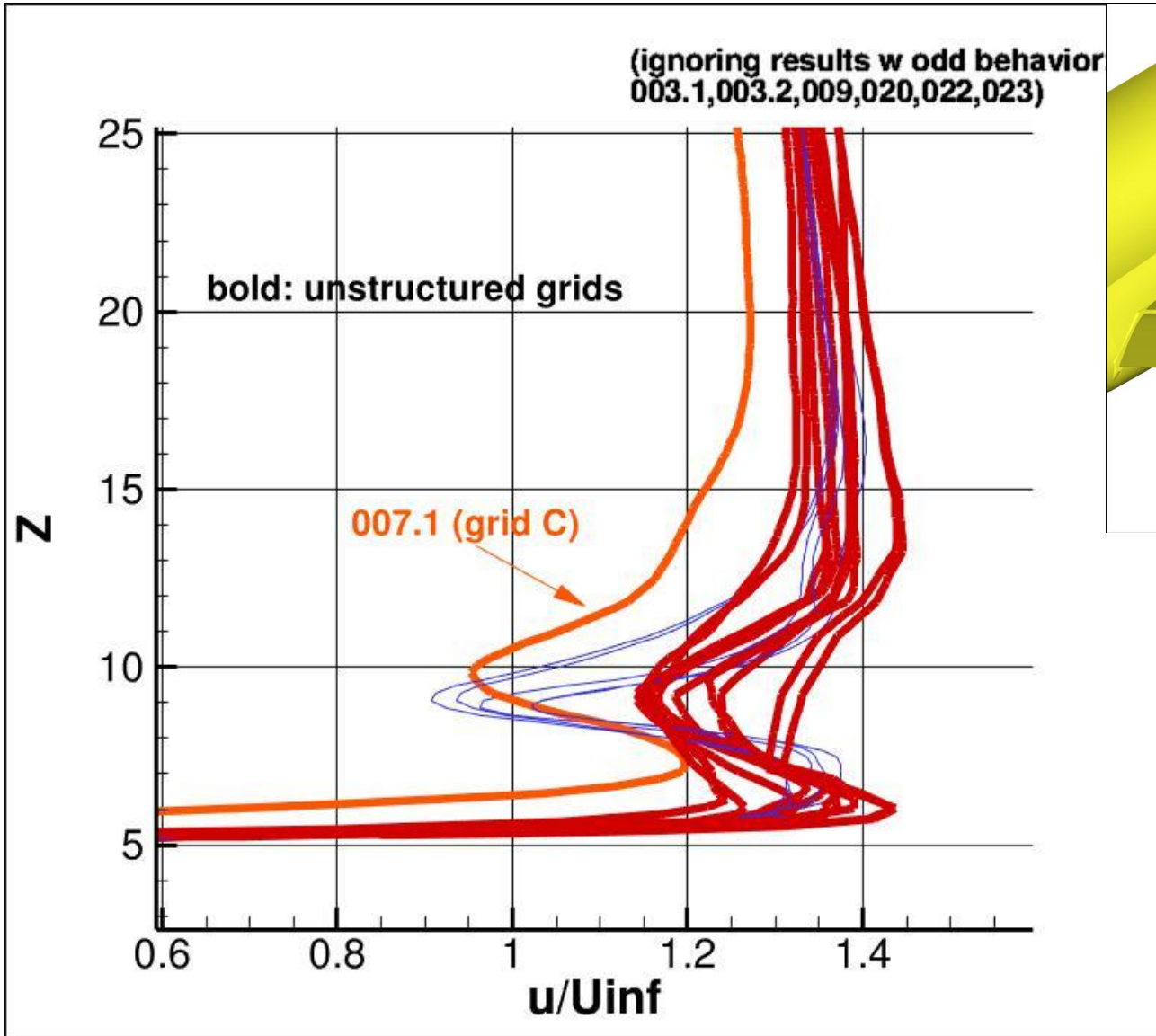

Case 2 Reynolds number effect

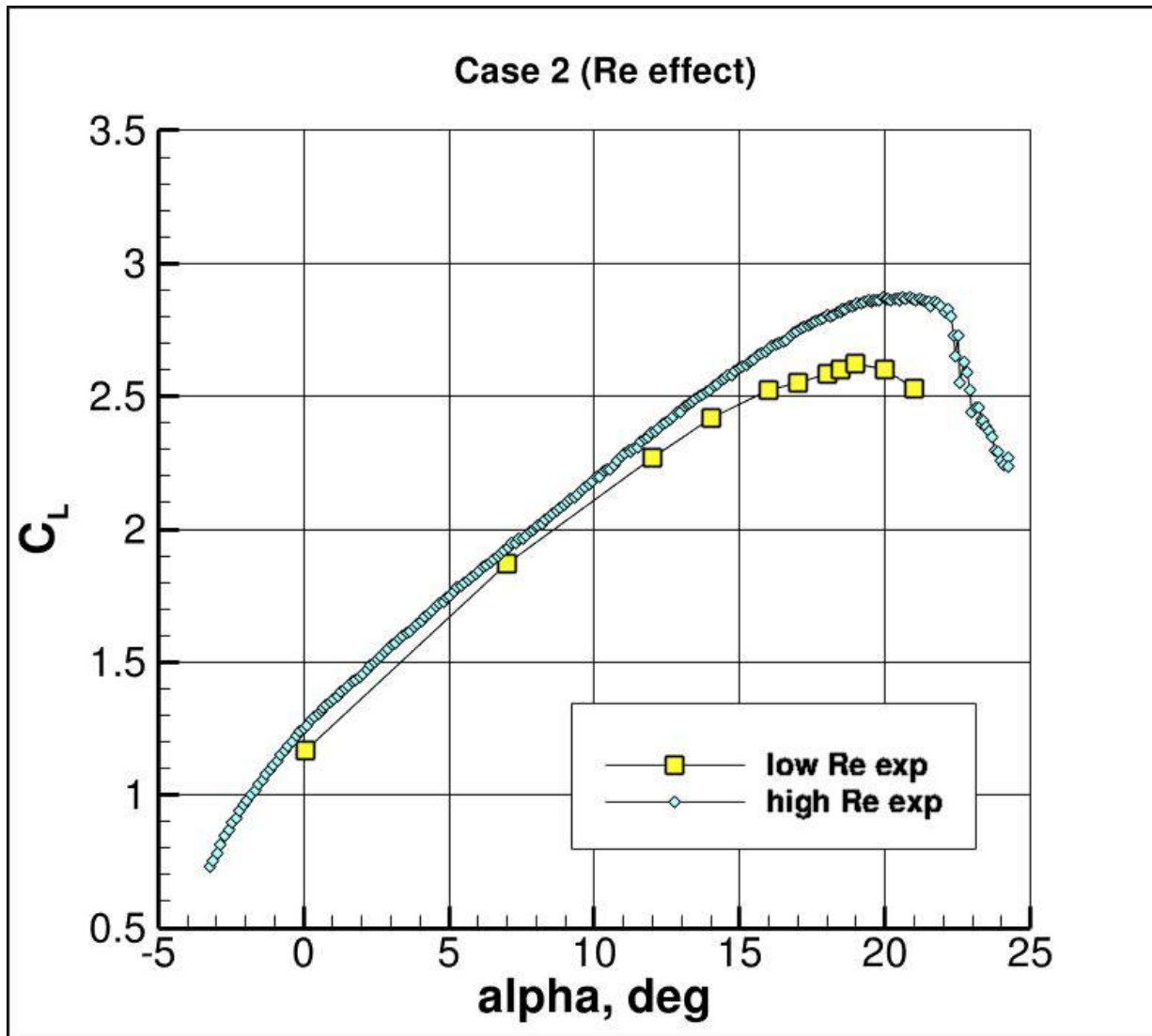

Case 2 Reynolds number effect

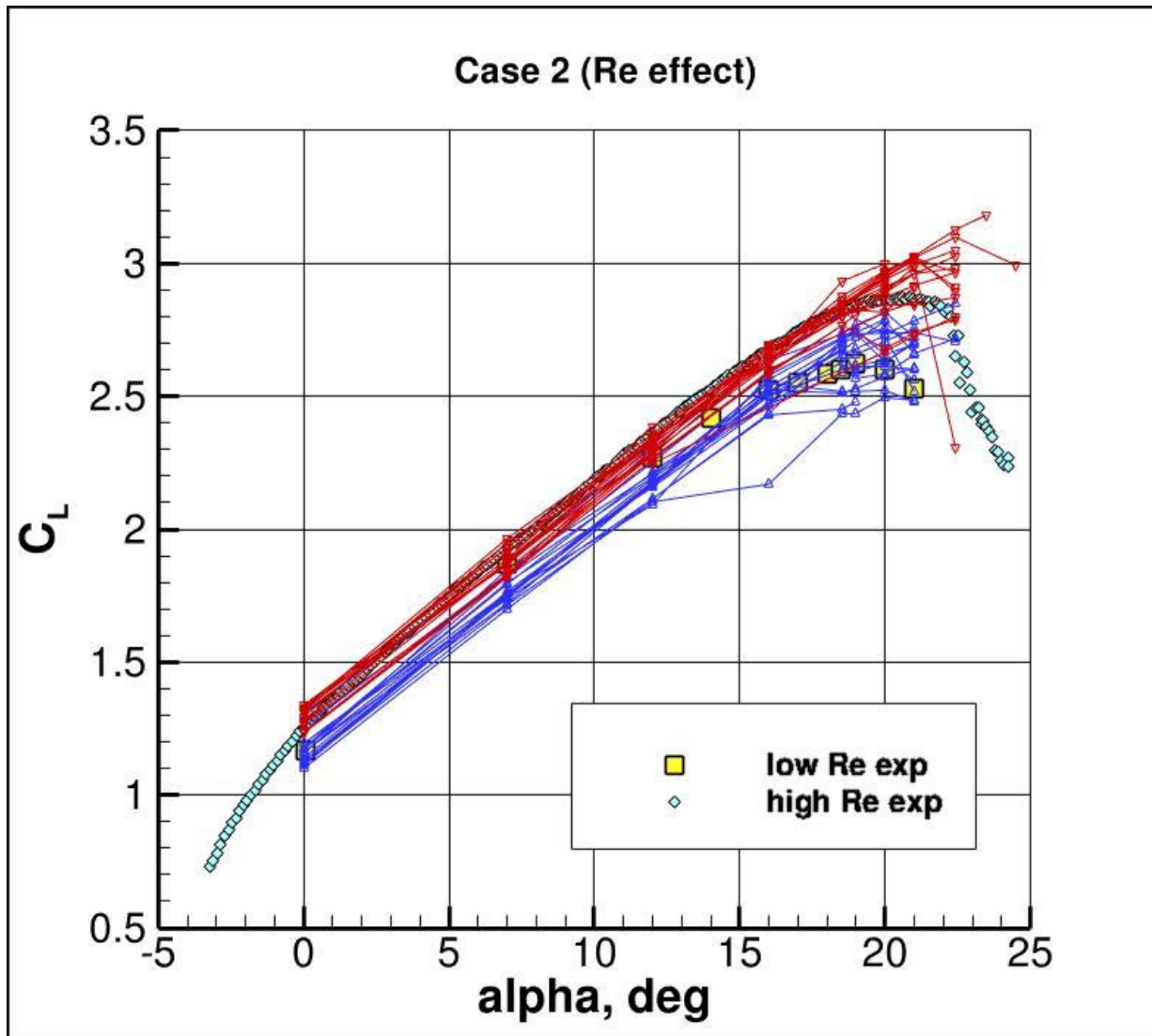

Case 2b adaptive result at high Re

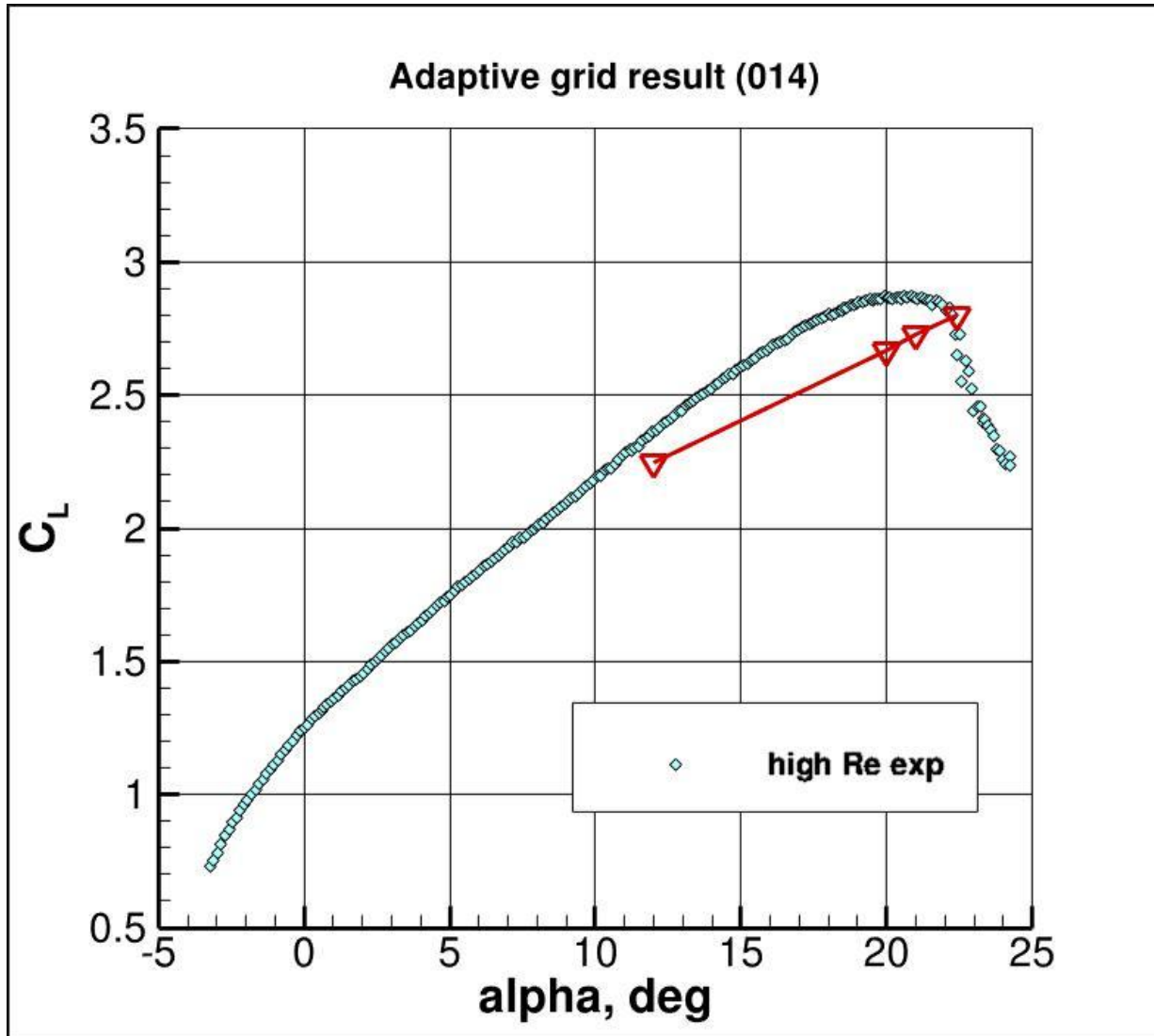

Case 2 Reynolds number effect

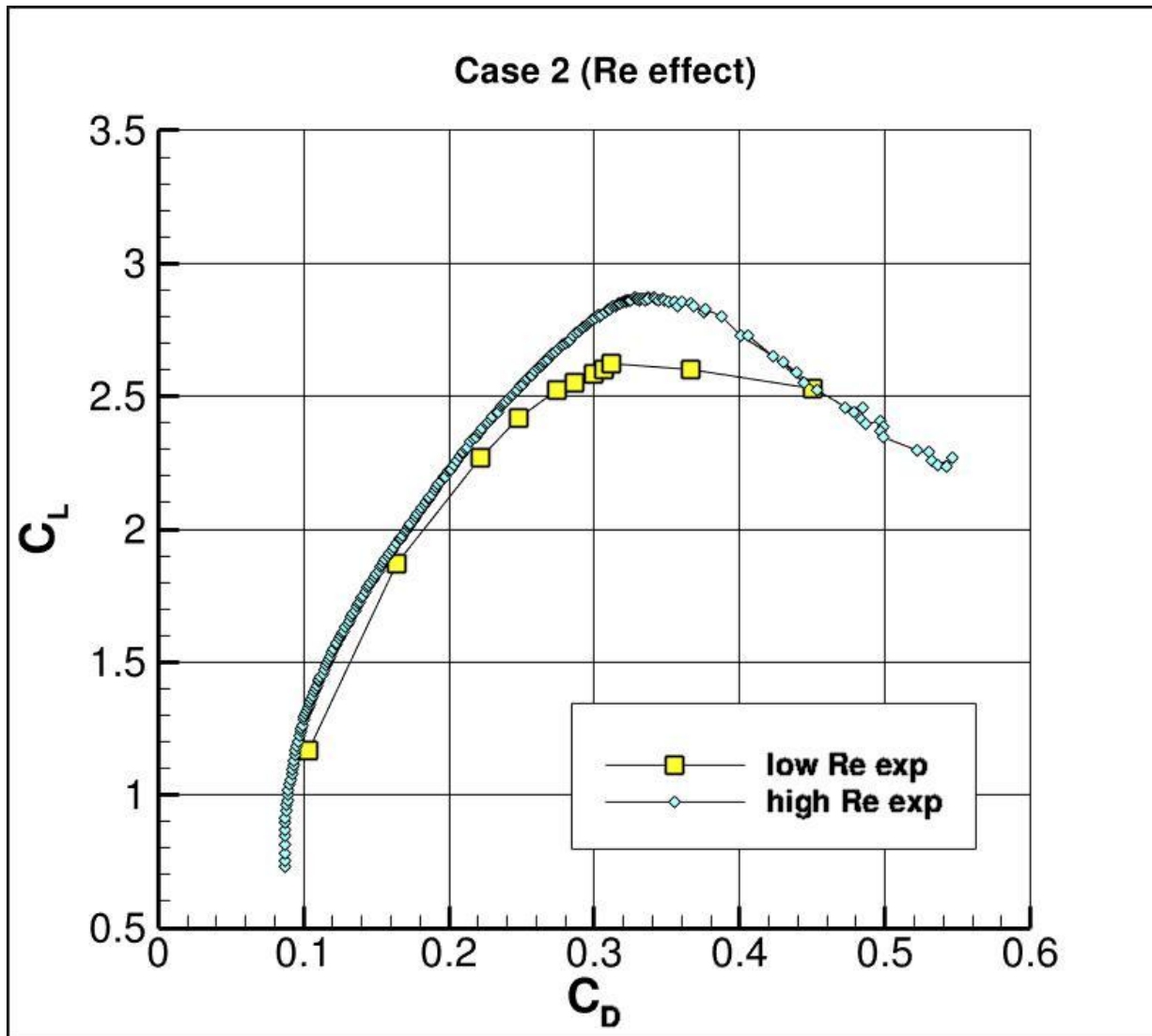

Case 2 Reynolds number effect

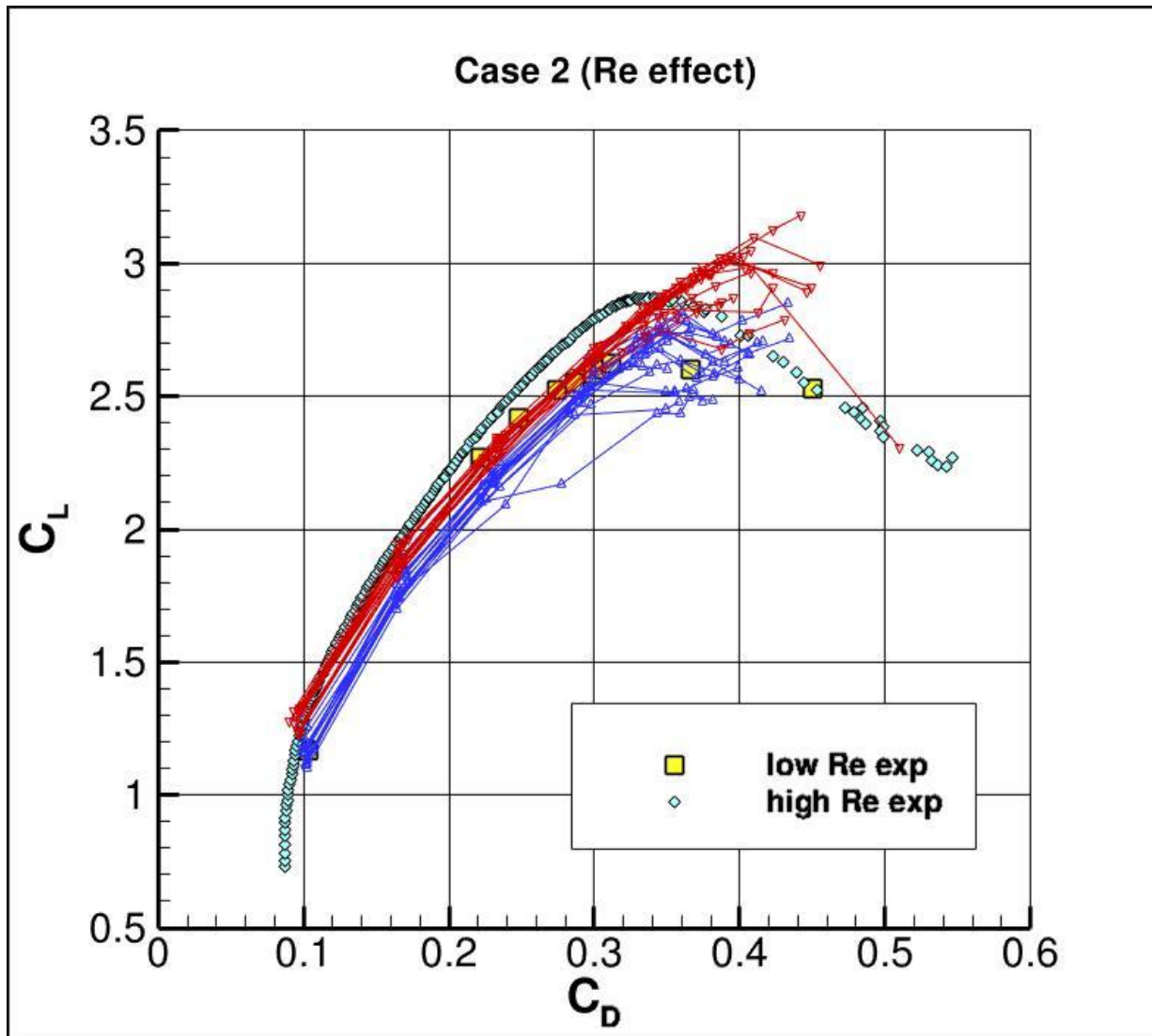

Case 2b adaptive result at high Re

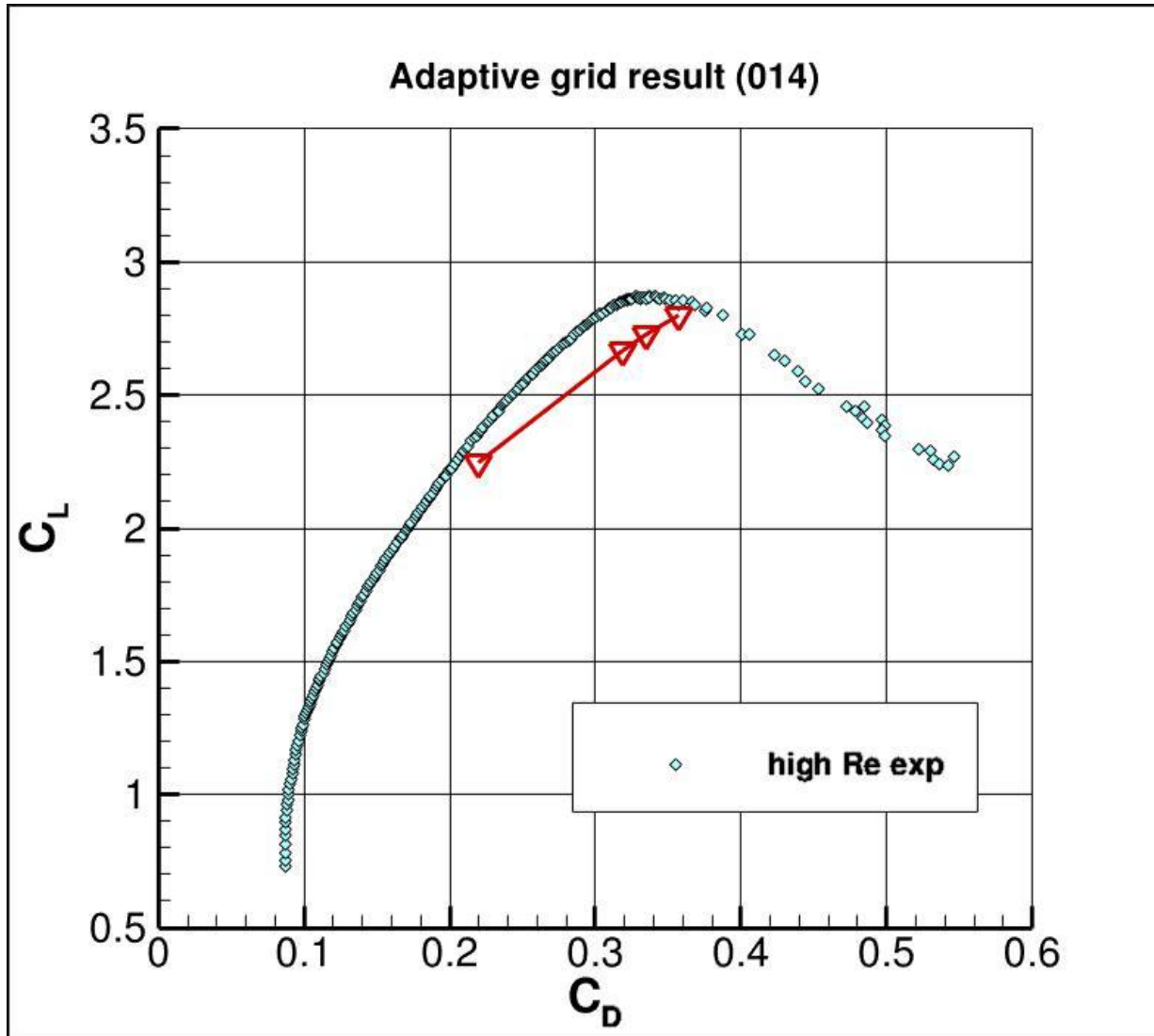

Case 2 Reynolds number effect

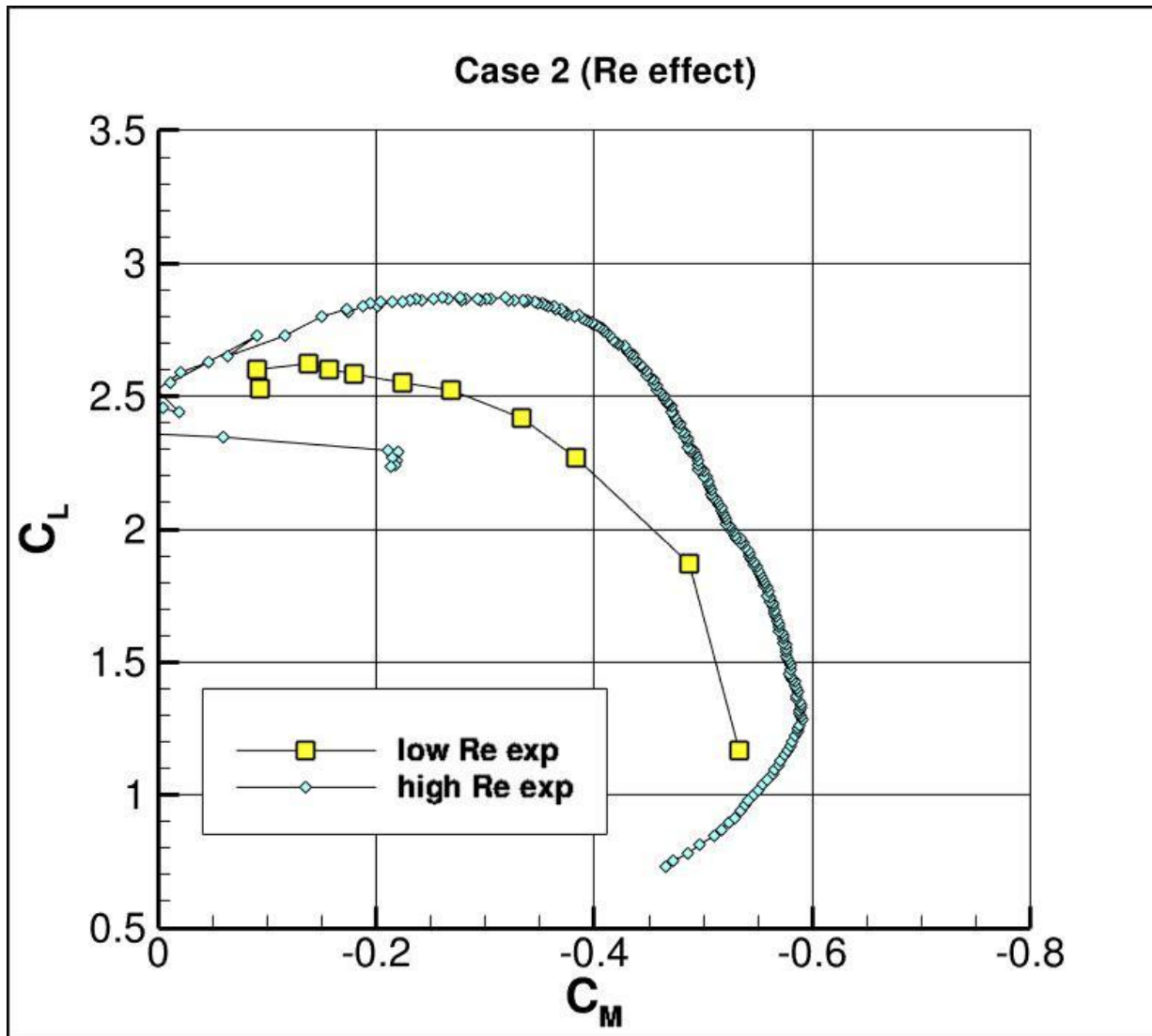

Case 2 Reynolds number effect

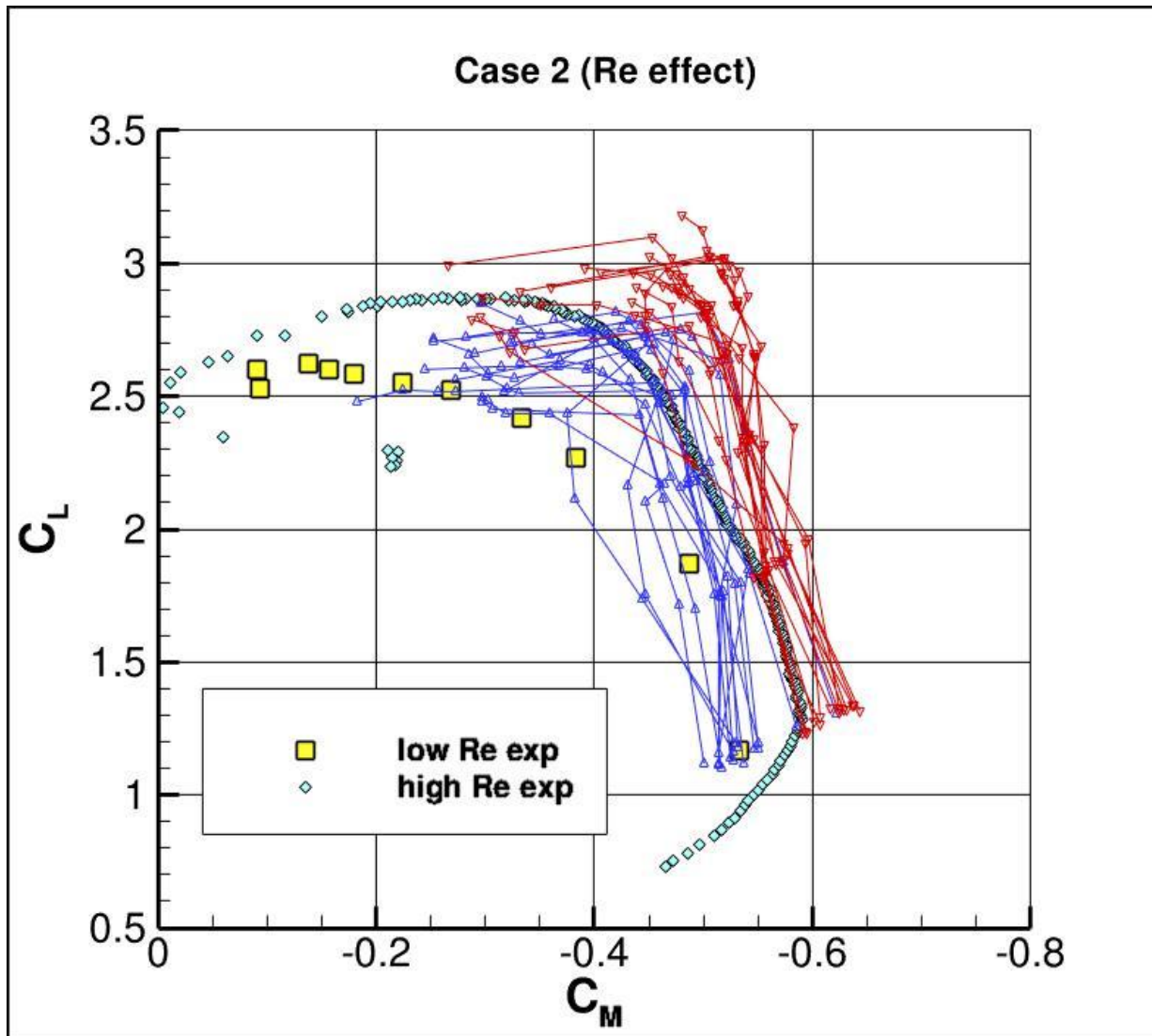

Case 2b adaptive result at high Re

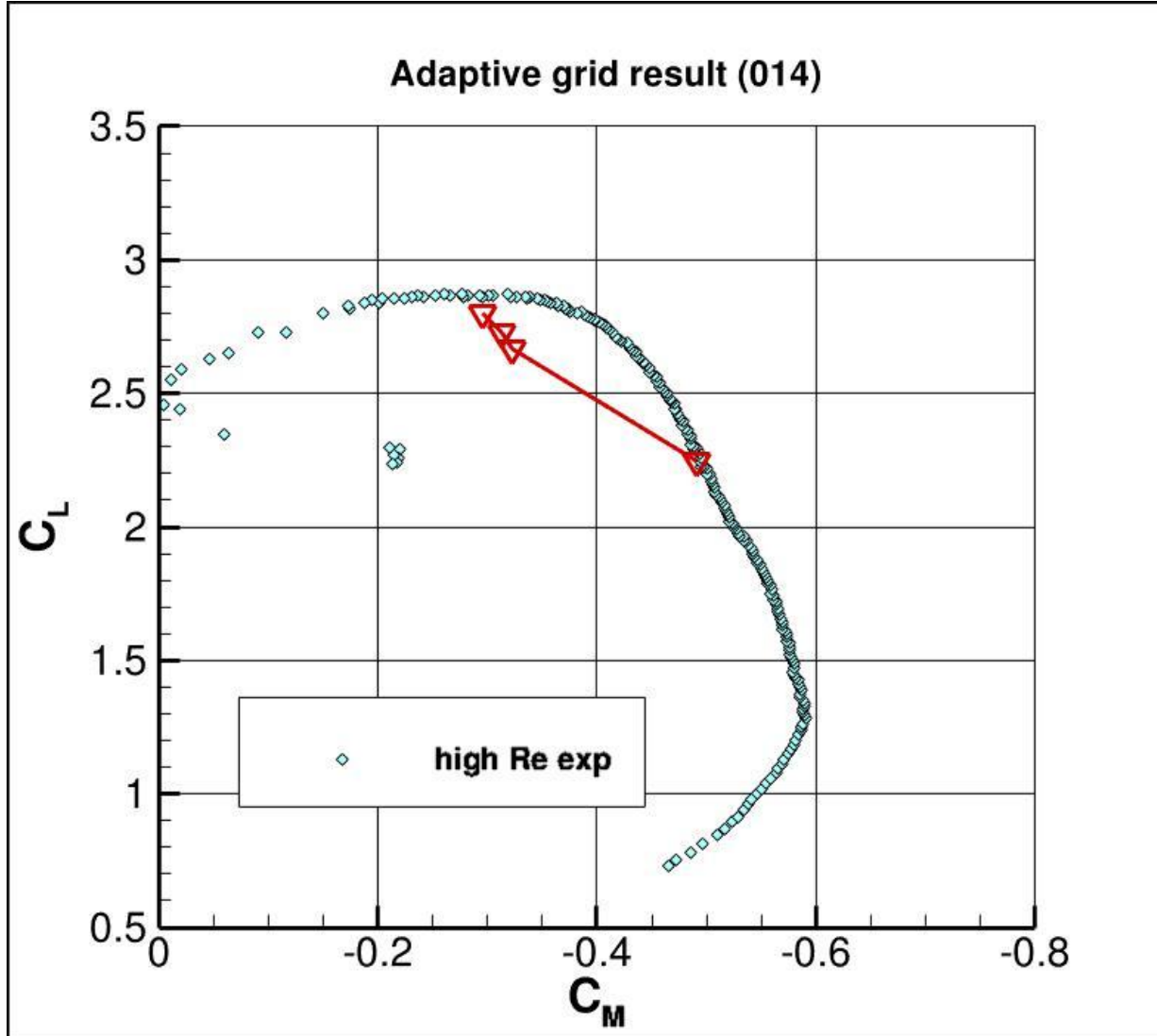

Case 2 Transition effect

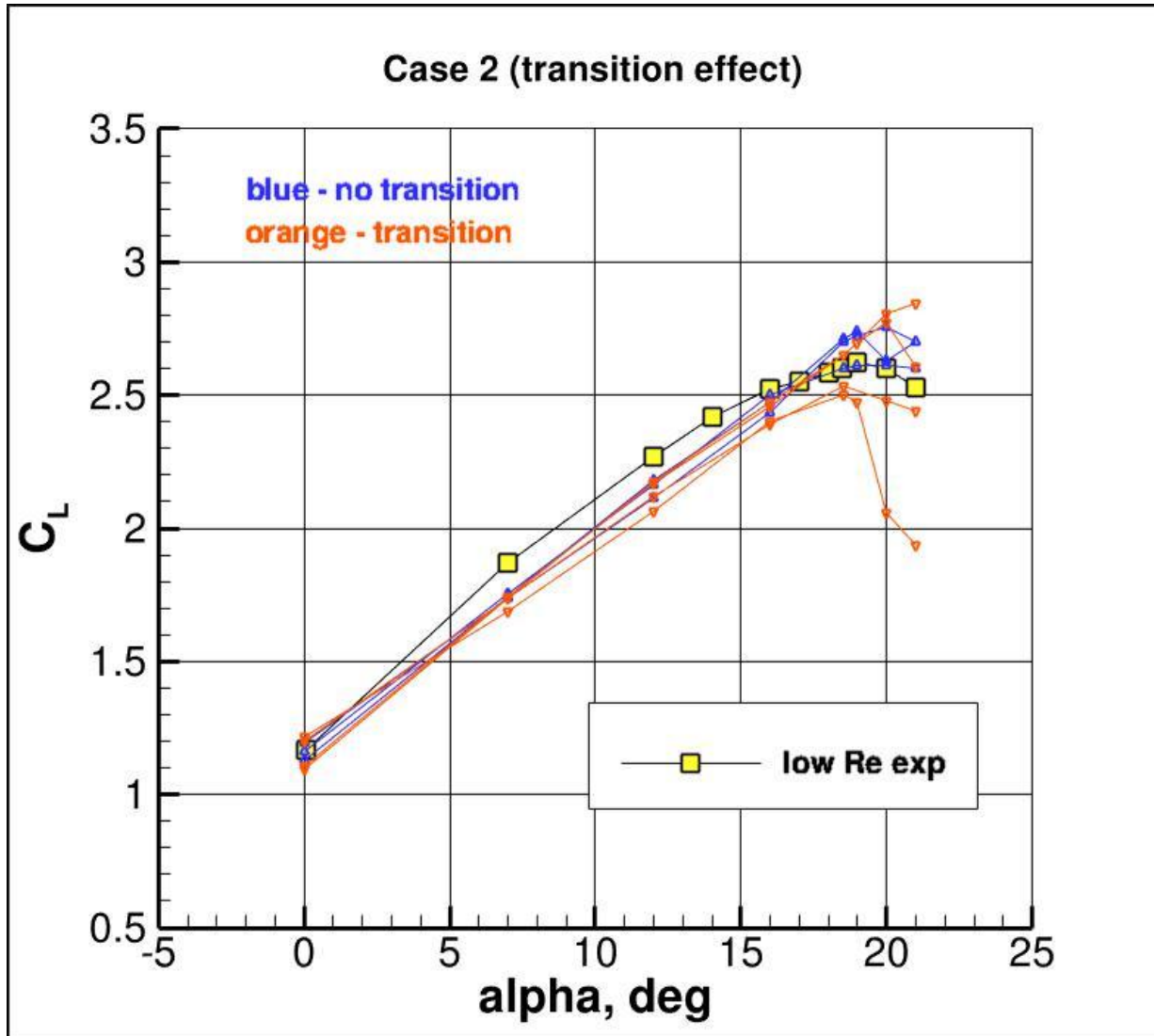

Case 2 Transition effect

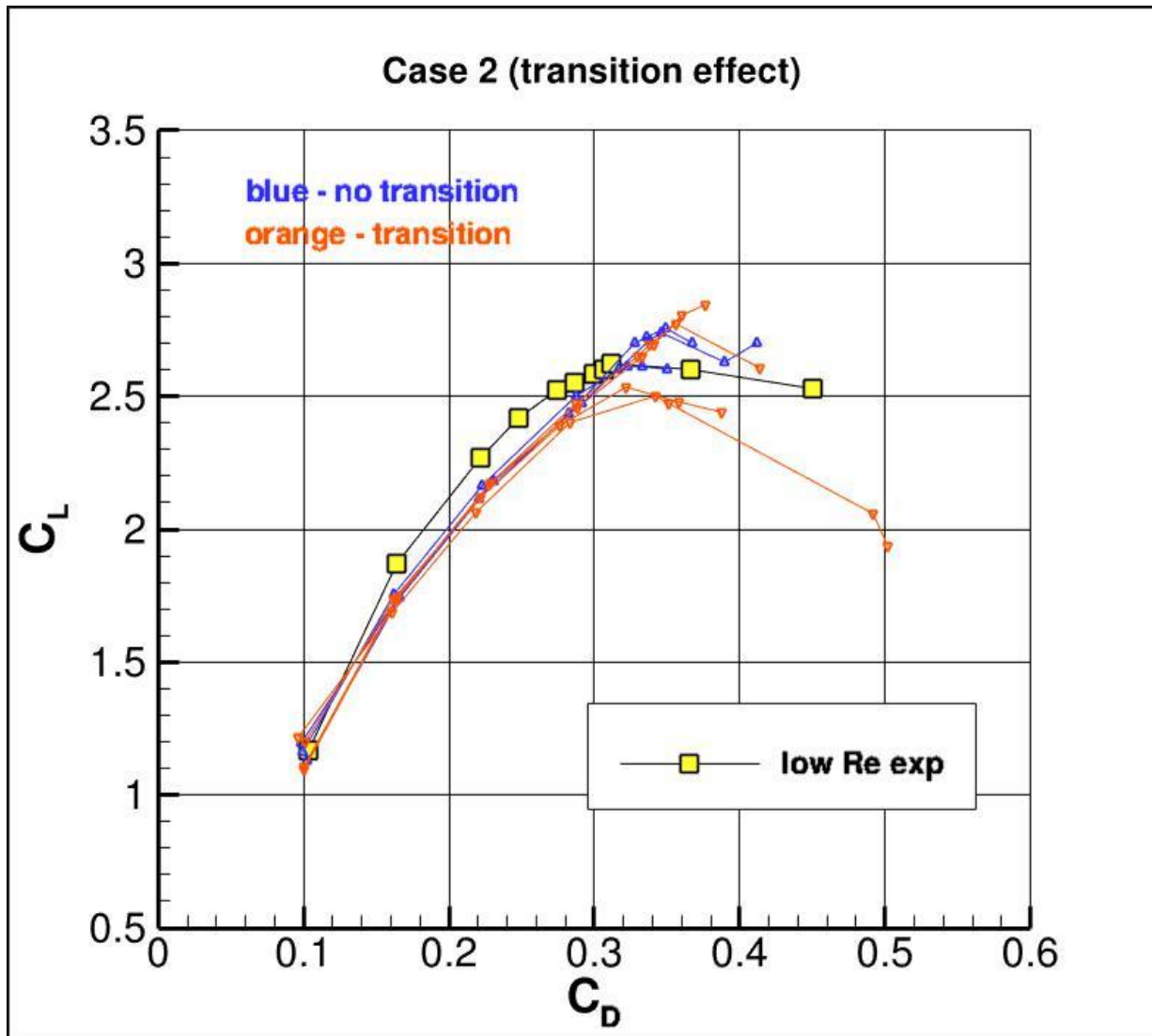

Case 3 Bundle effect

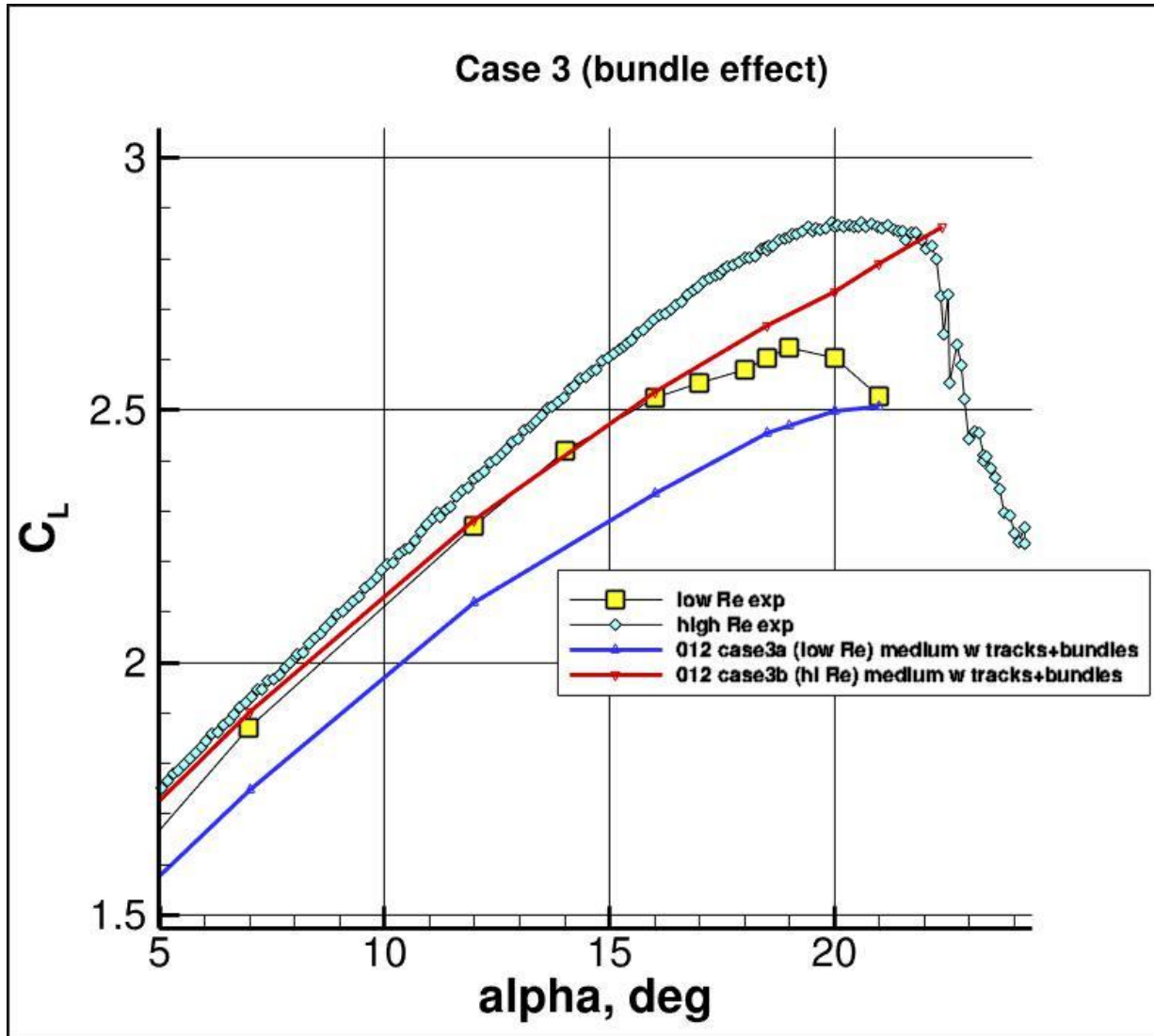

Case 3 Bundle effect

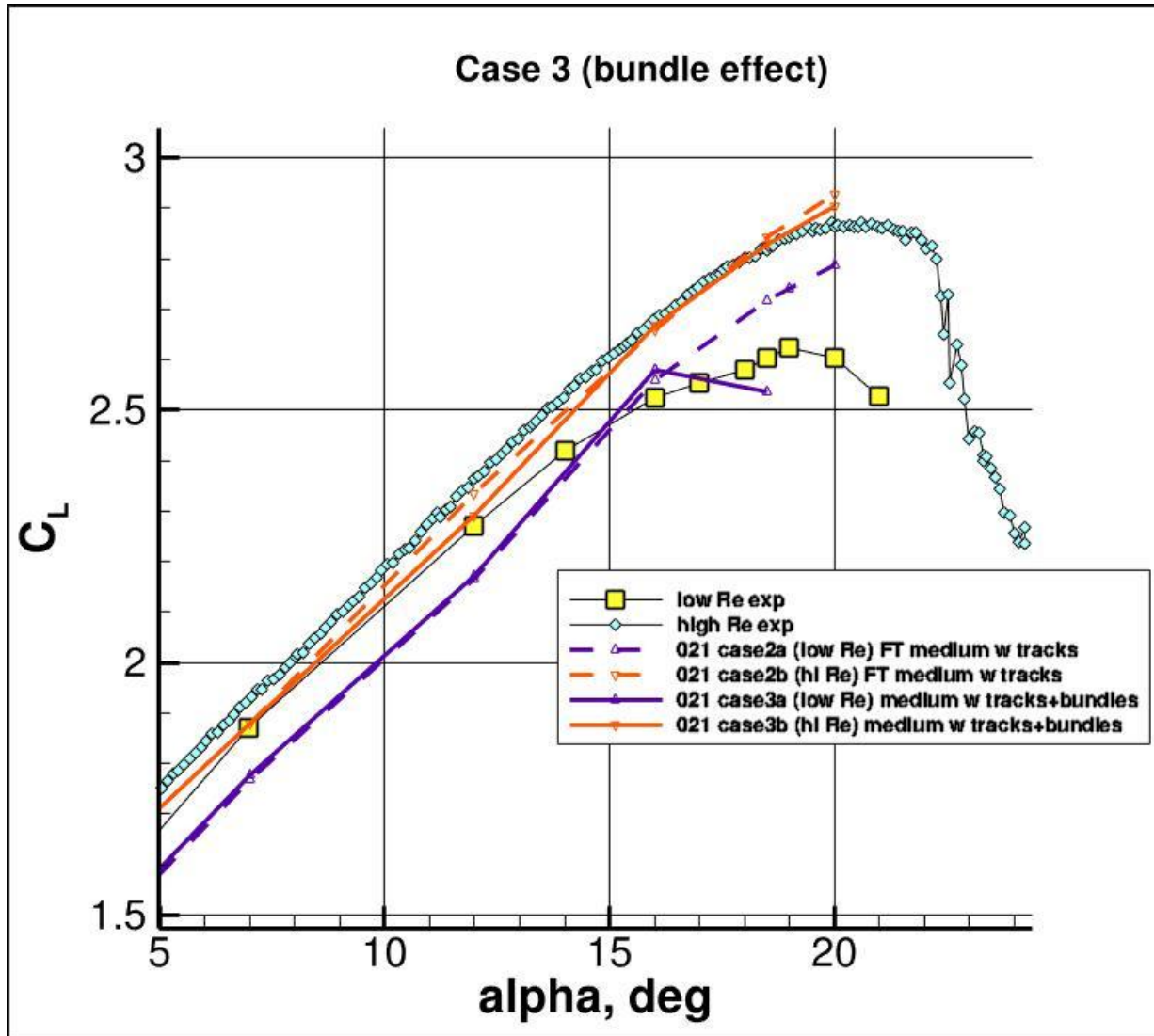

Case 3 Bundle effect

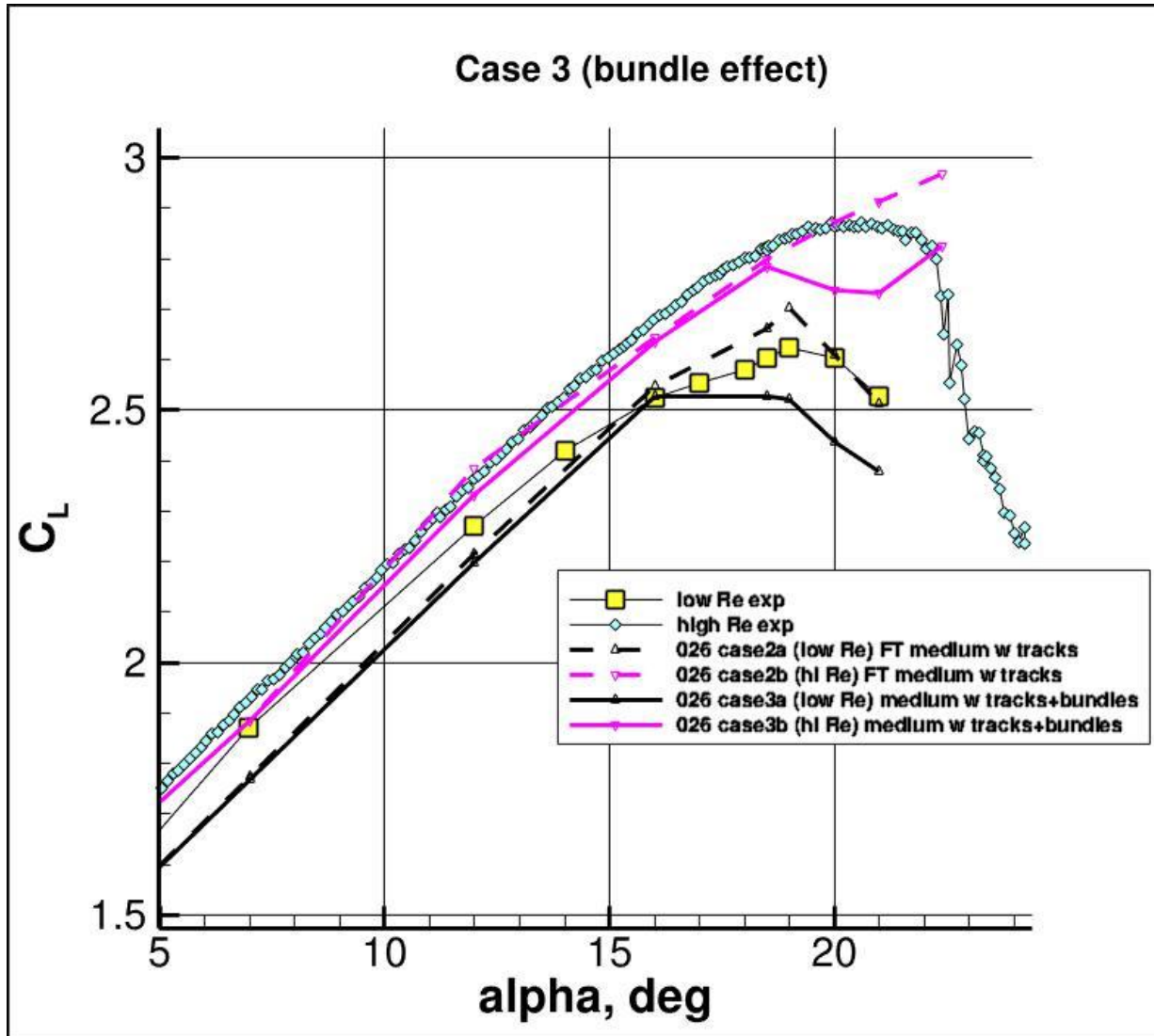

Surface pressure coefficients, AoA=7

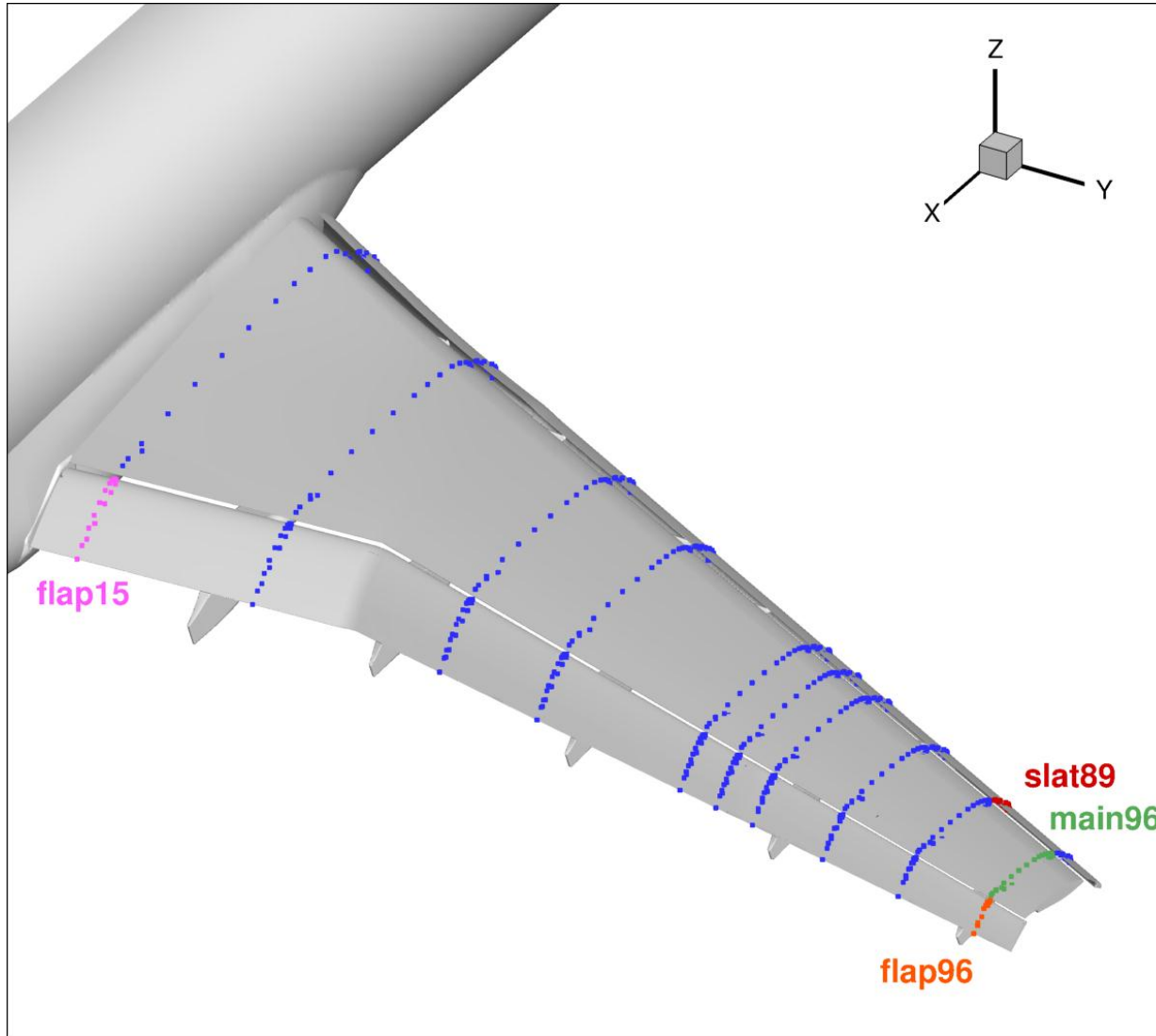

Cps at AoA=7, slat89

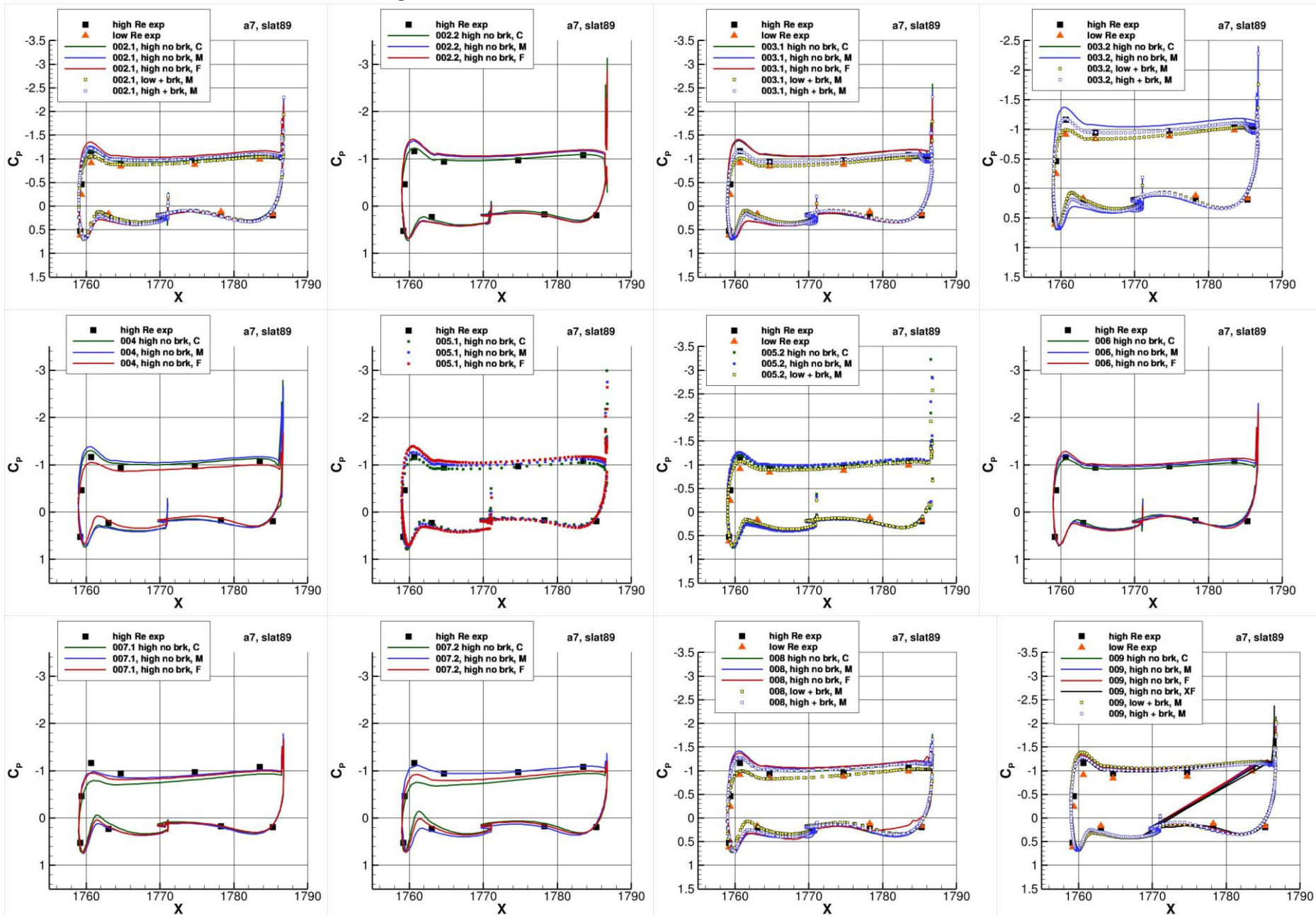

Cps at AoA=7, slat89

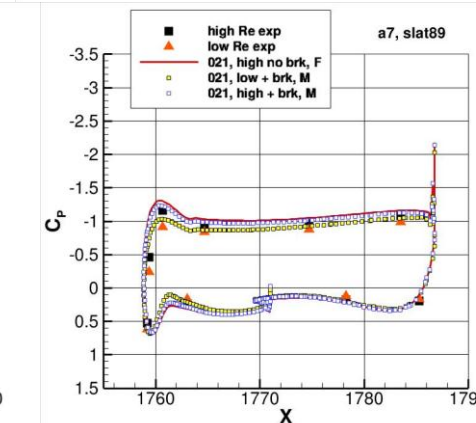
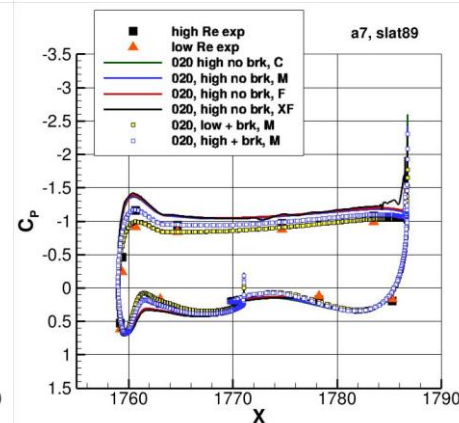
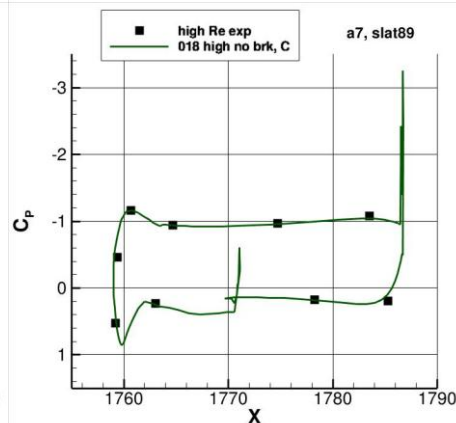
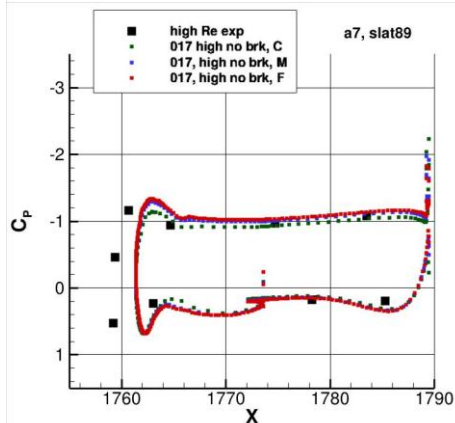
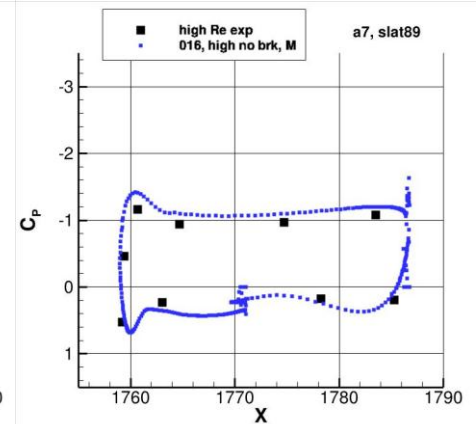
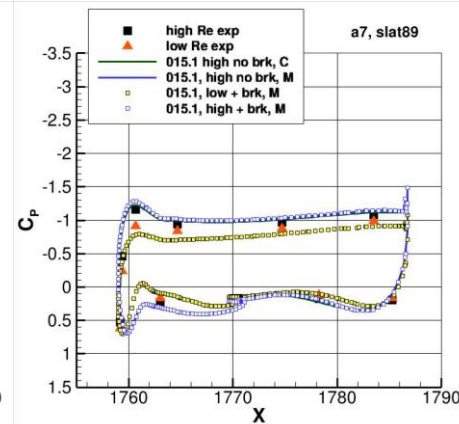
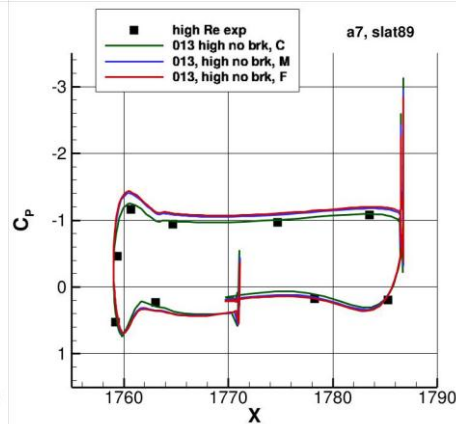
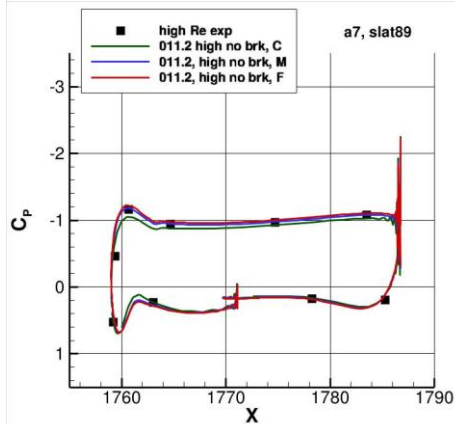
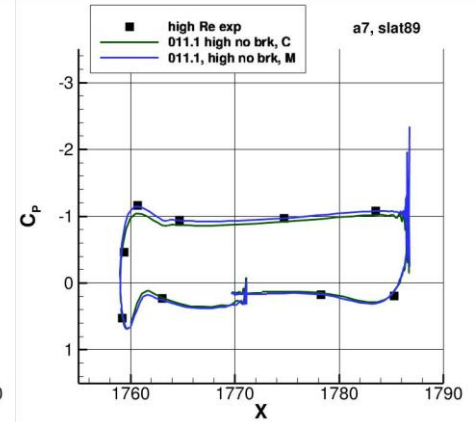
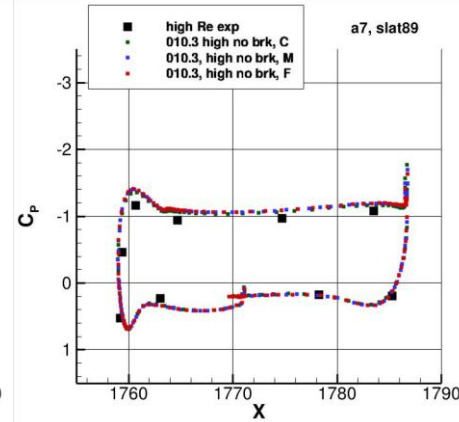
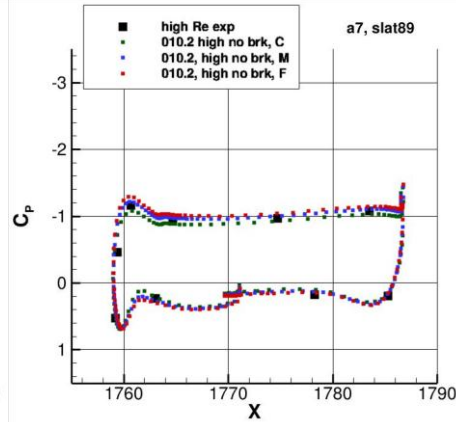
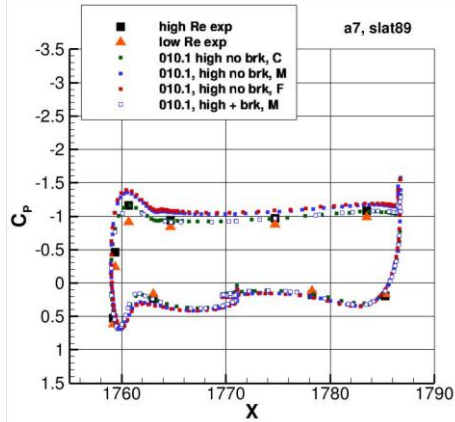

Cps at AoA=7, slat89

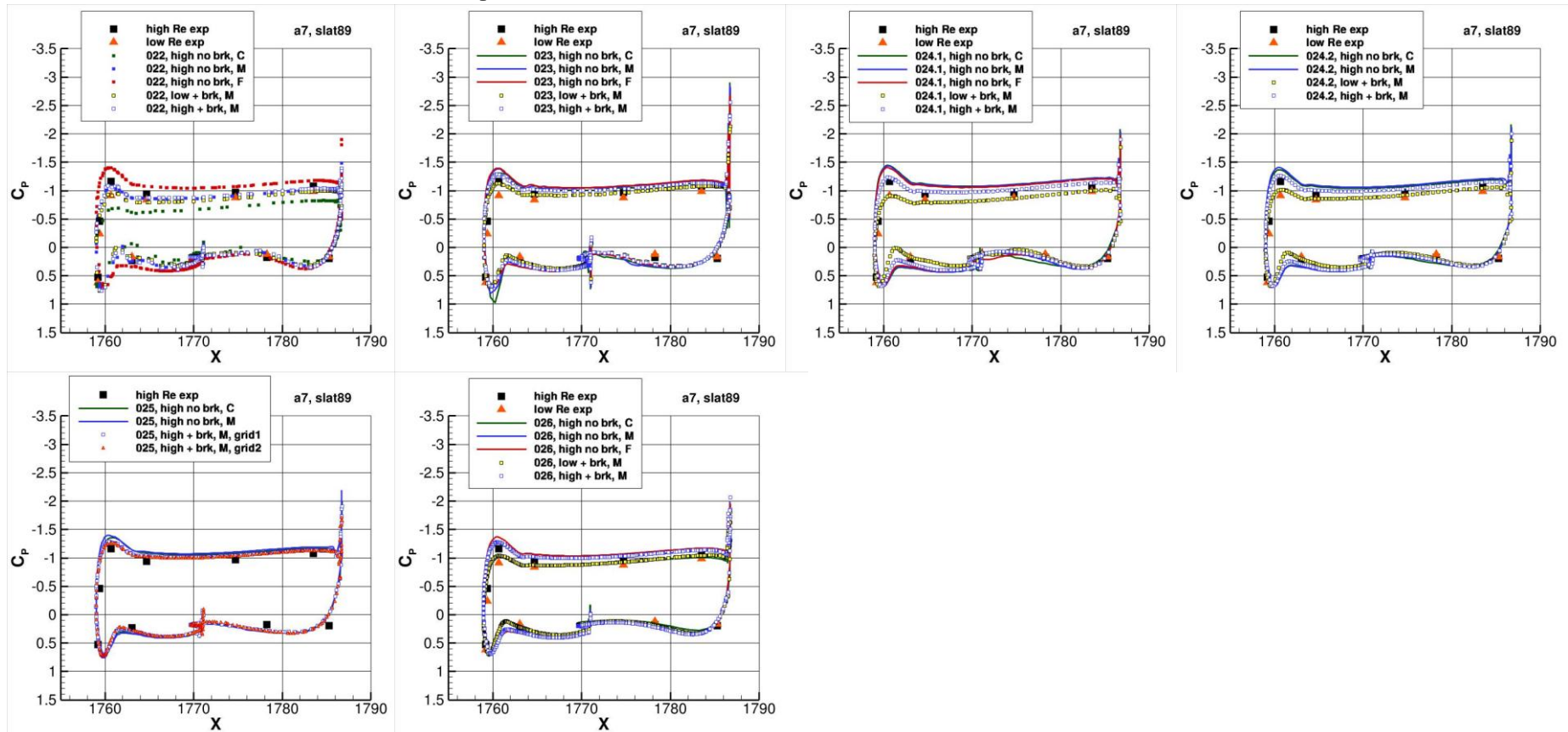

Runs w brackets tend to do better
Re effect qualitatively captured
Some results show more grid-dependence
017 used shifted geometry (for all)

Cps at AoA=7, main96

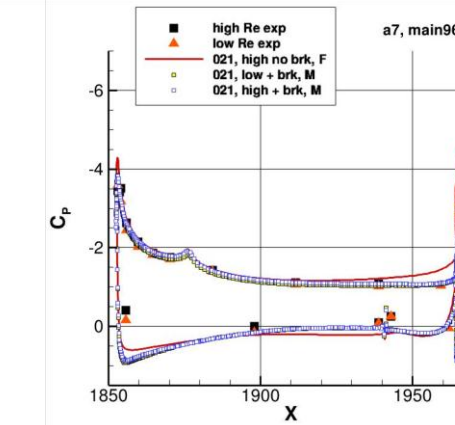
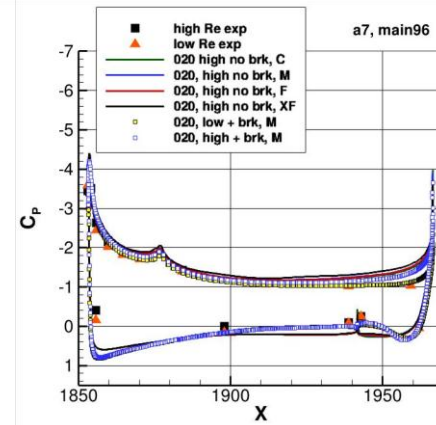
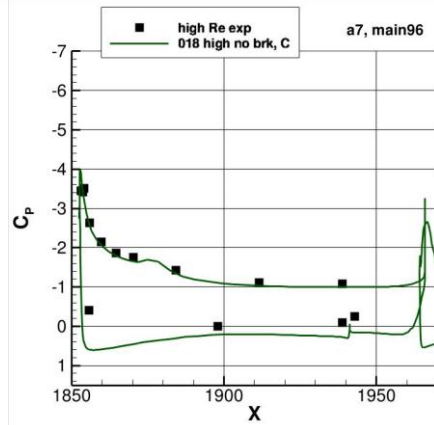
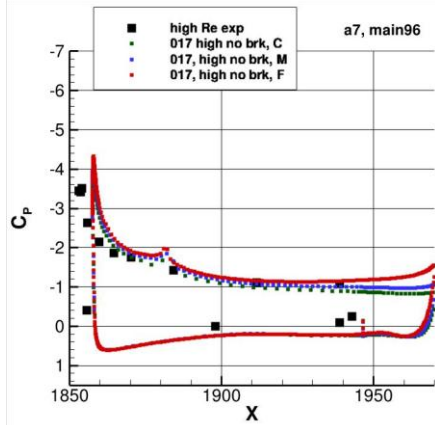
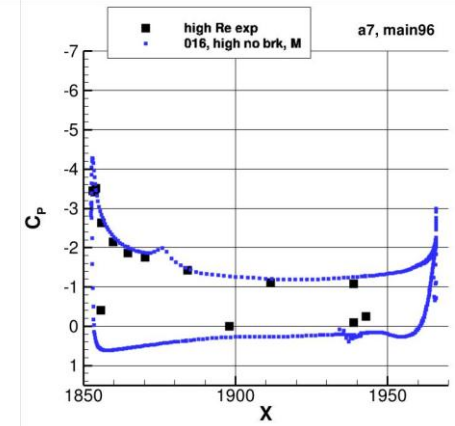
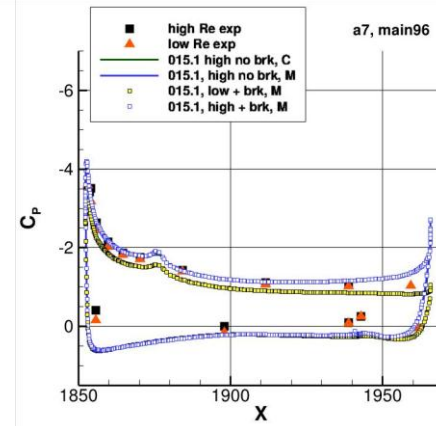
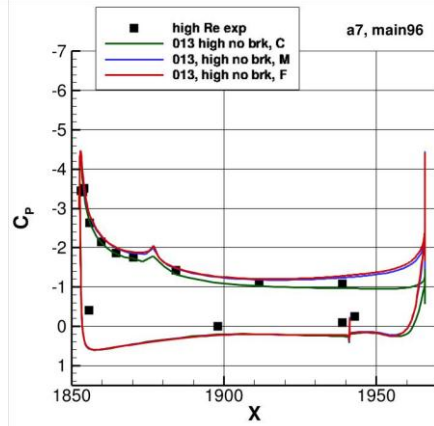
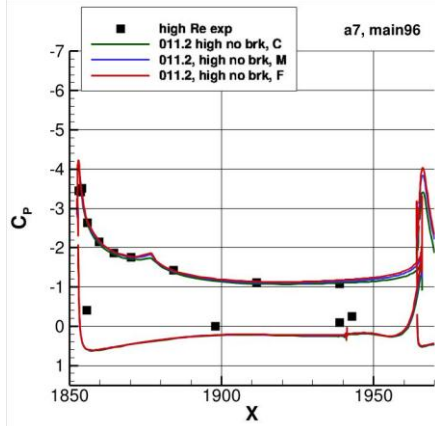
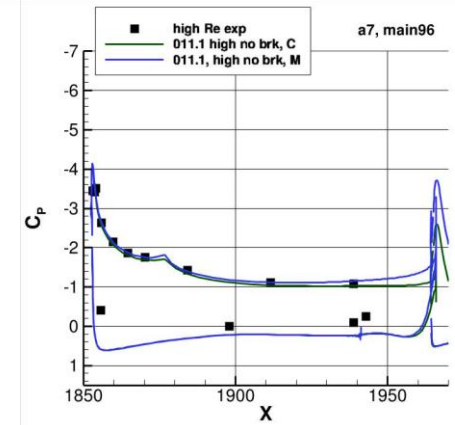
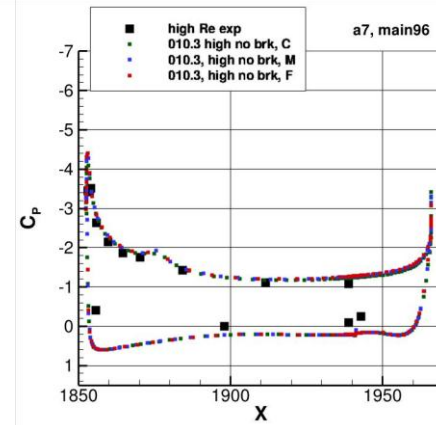
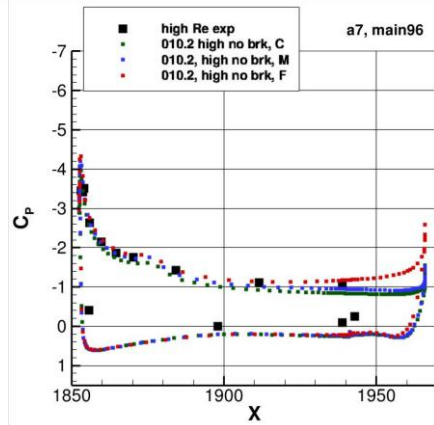
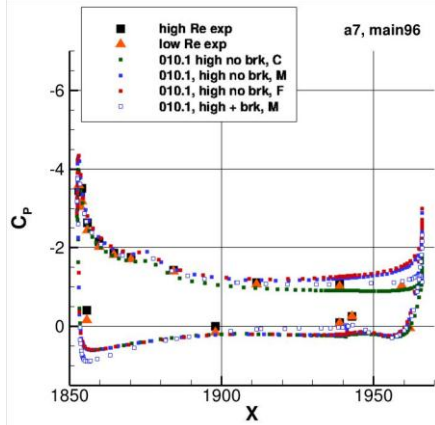

Cps at AoA=7, main96

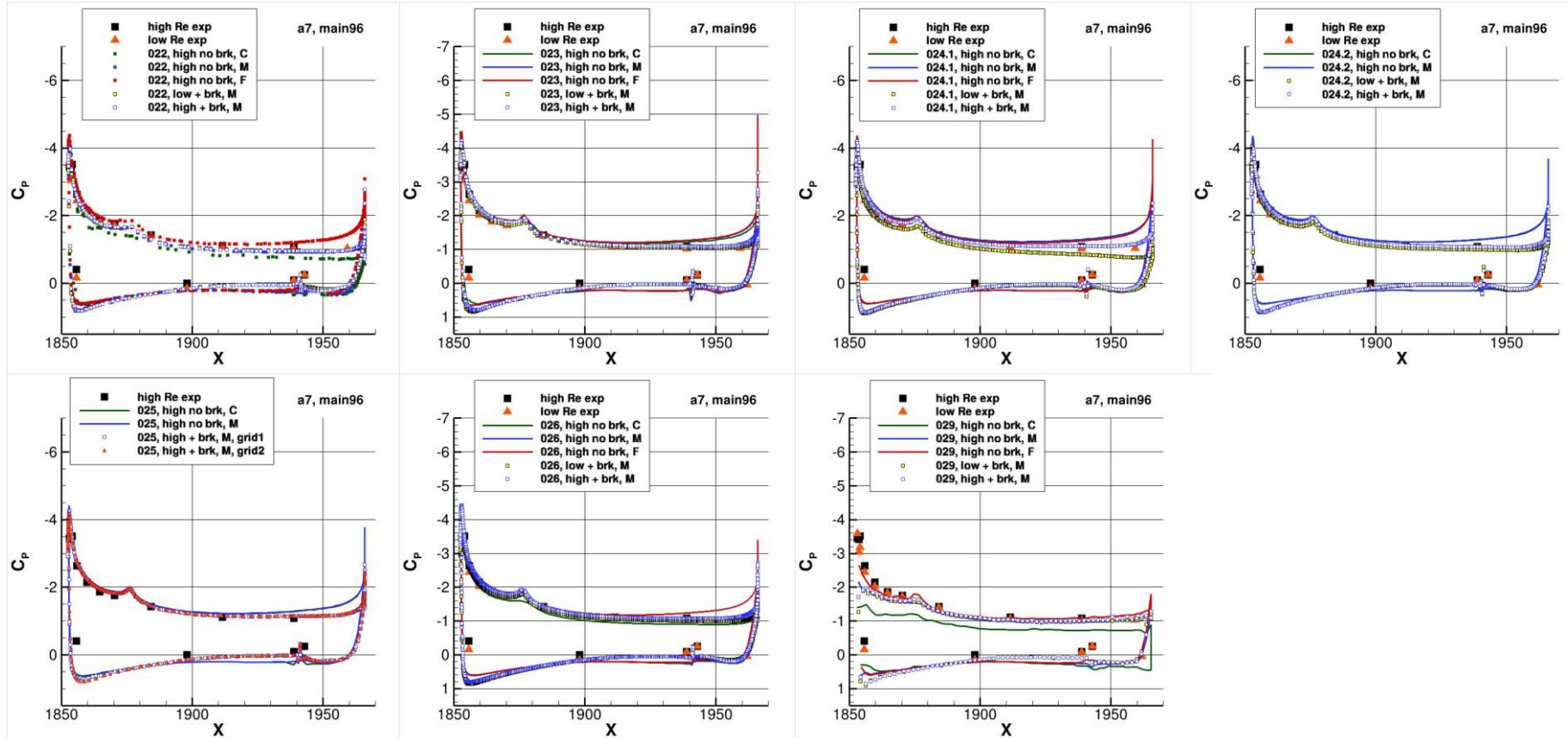

Runs w brackets tend to do better (rear)
Little noticeable Re effect

Cps at AoA=7, flap15

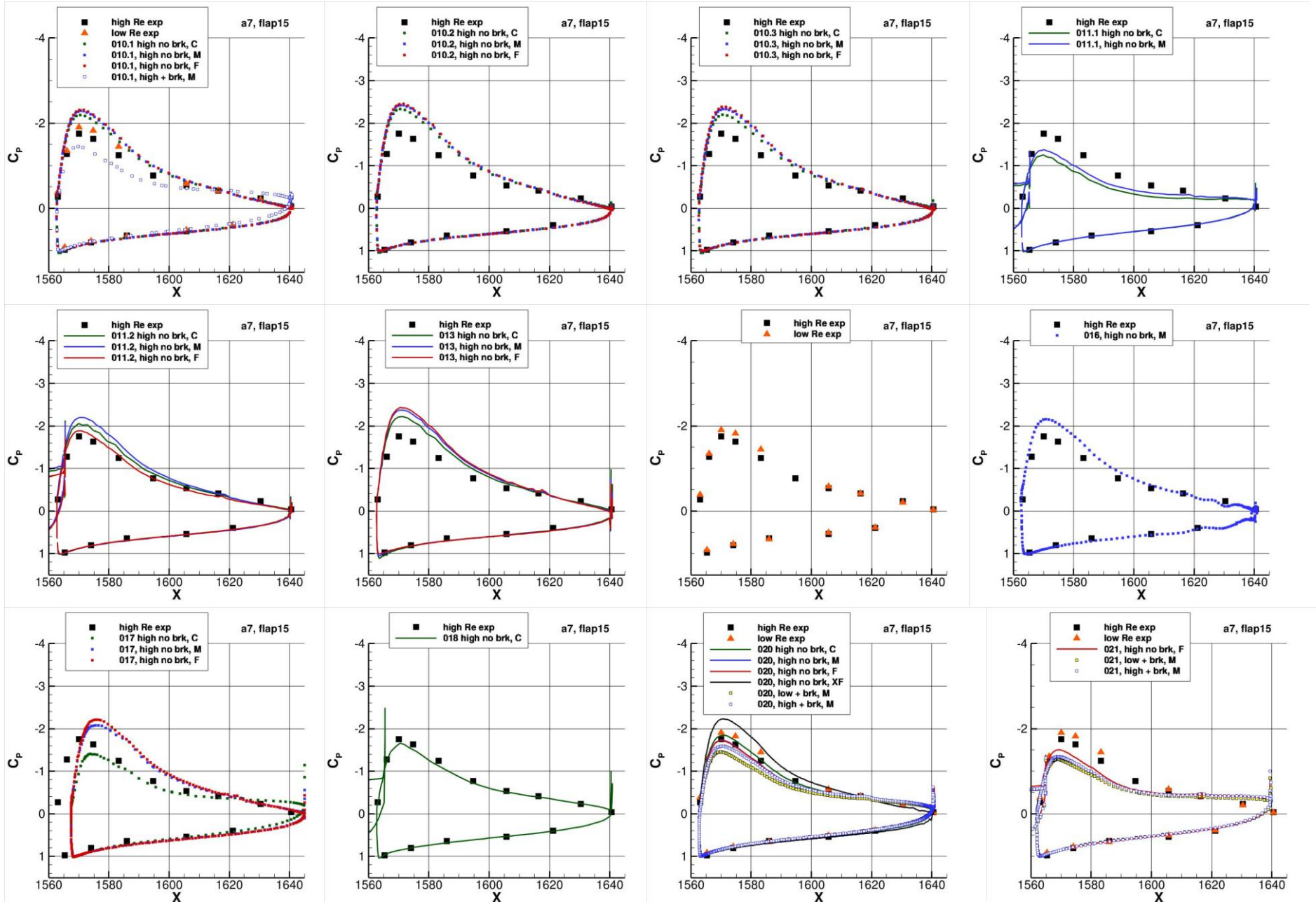

Cps at AoA=7, flap15

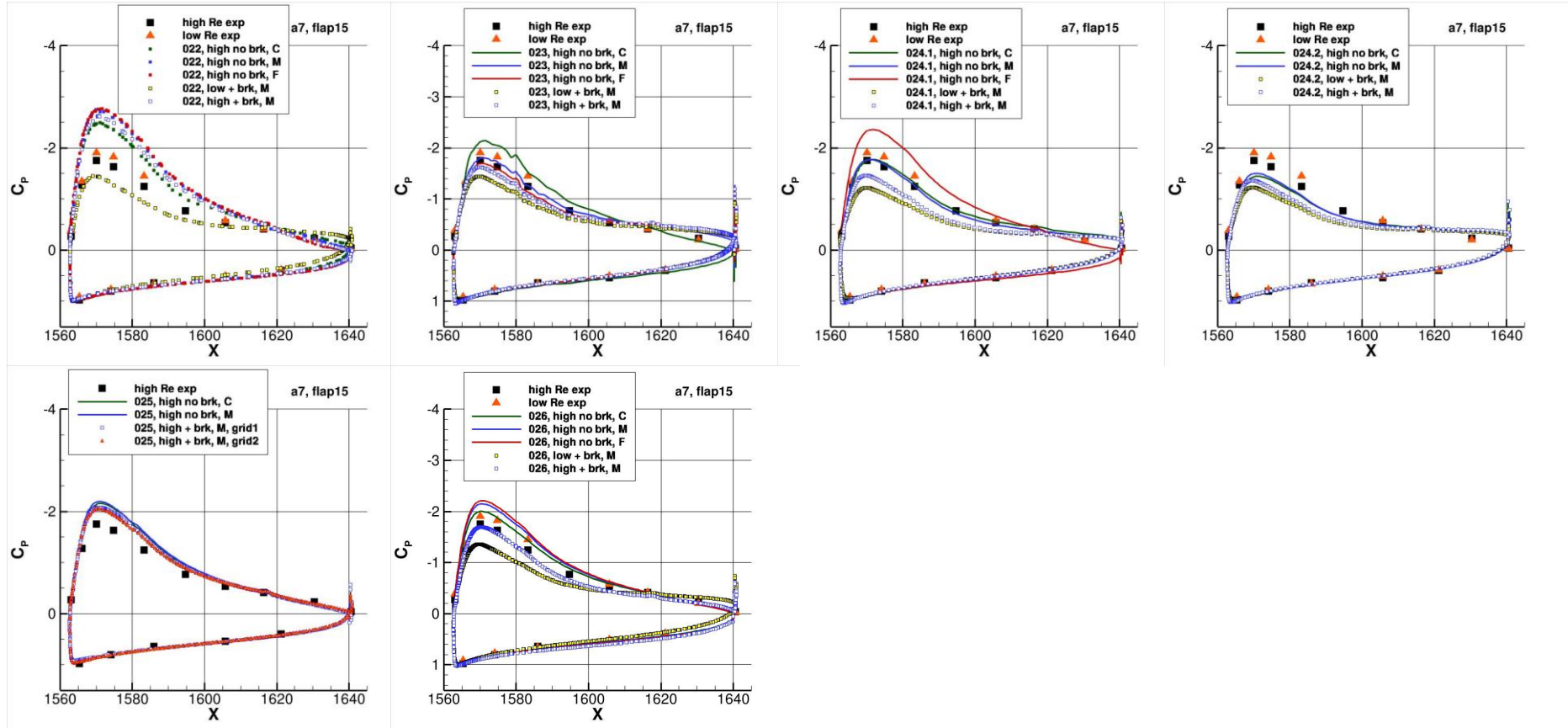

This station difficult to capture
Peak tends to be too great w/o brackets
... too low with brackets

Cps at AoA=7, flap96

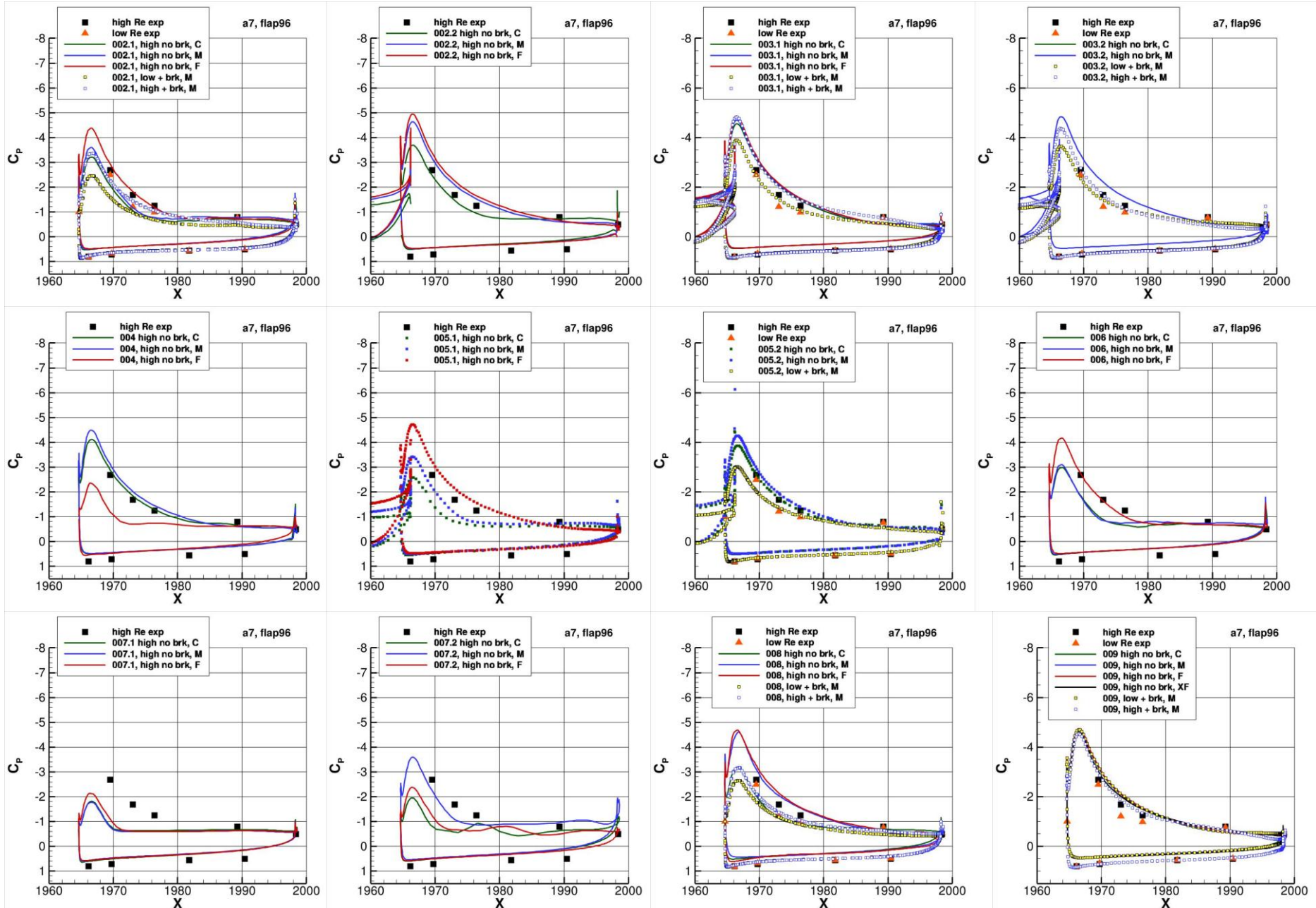

Cps at AoA=7, flap96

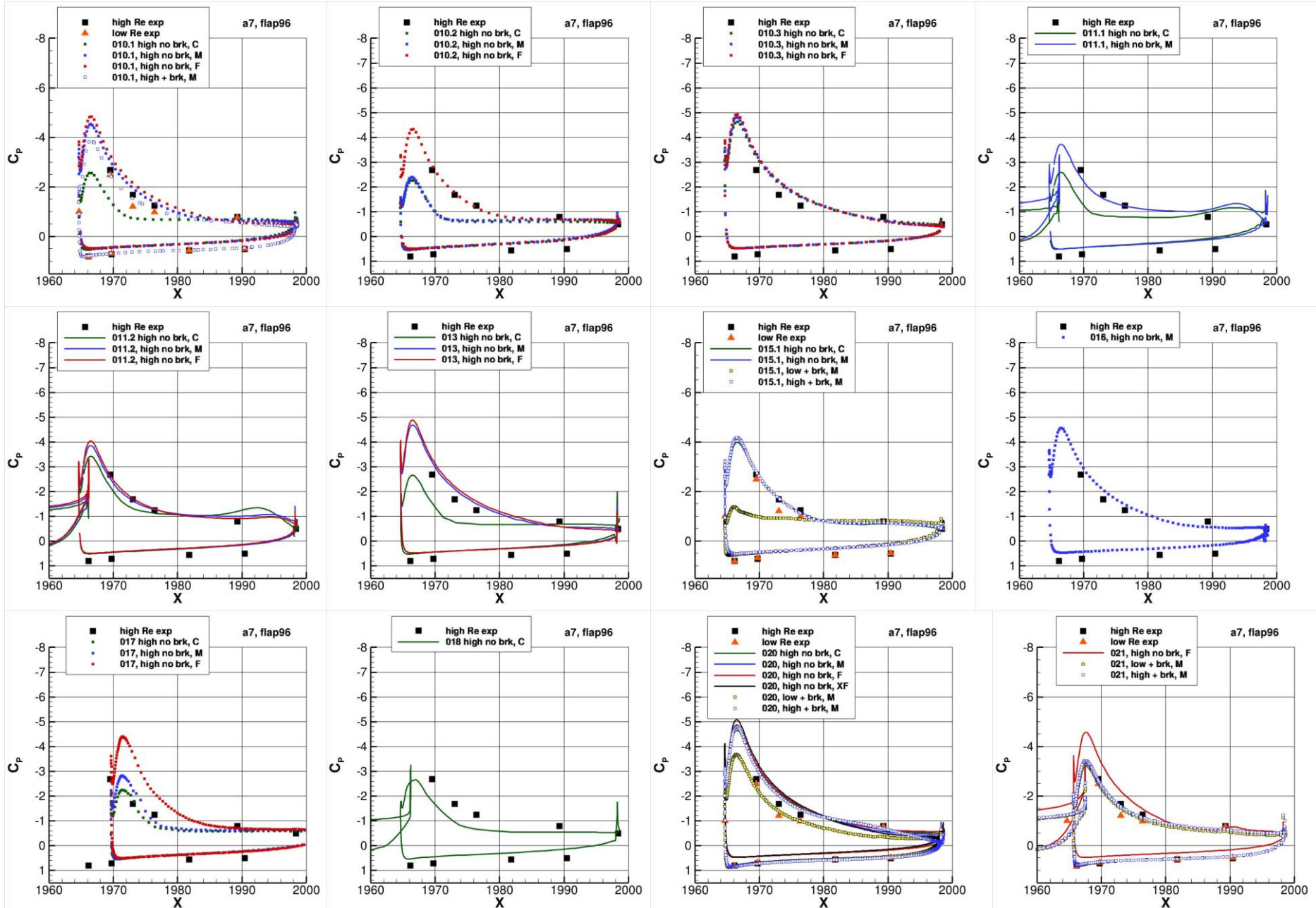

Cps at AoA=7, flap96

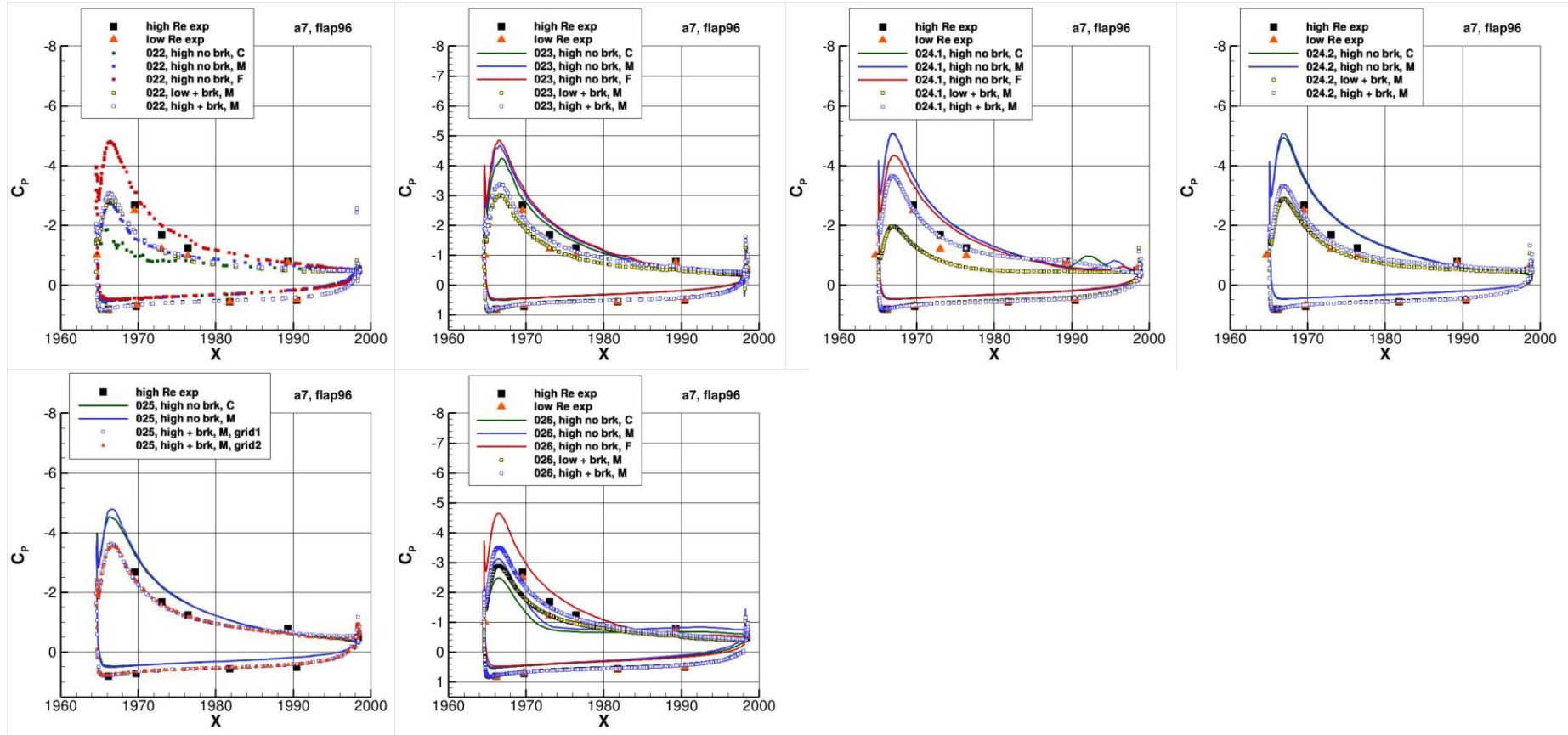

This station difficult to capture
More variation between results here
Runs w brackets tend to do better
Re effect qualitatively captured by some
Several results: massive separation

Transition effect at AoA=7

(Only one participant with readable Cp file at AoA=7)

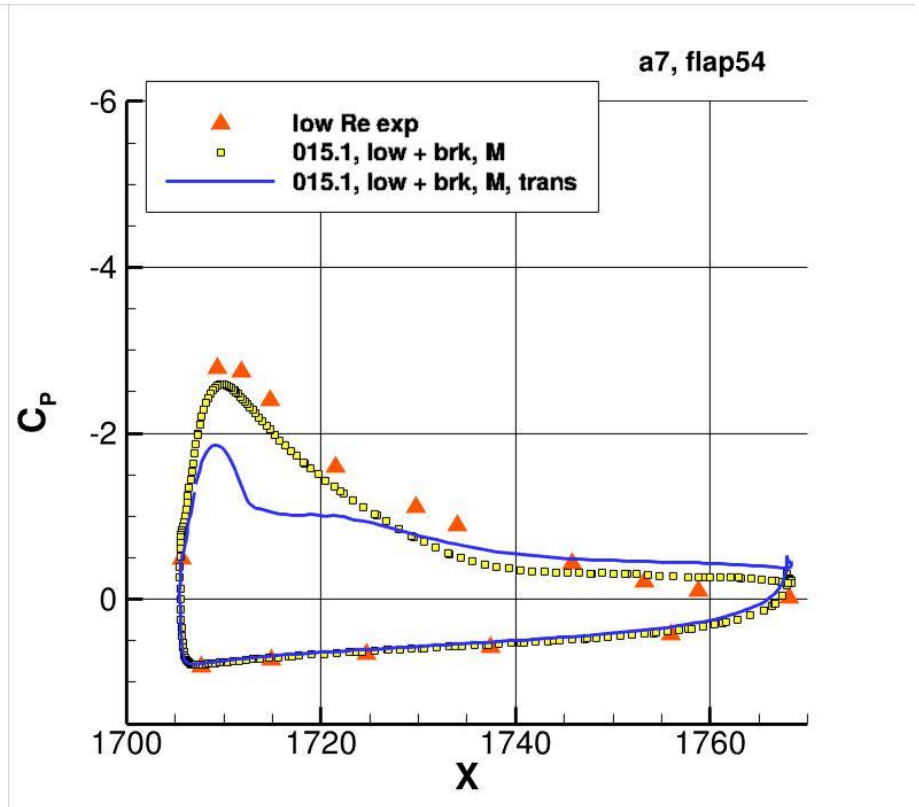
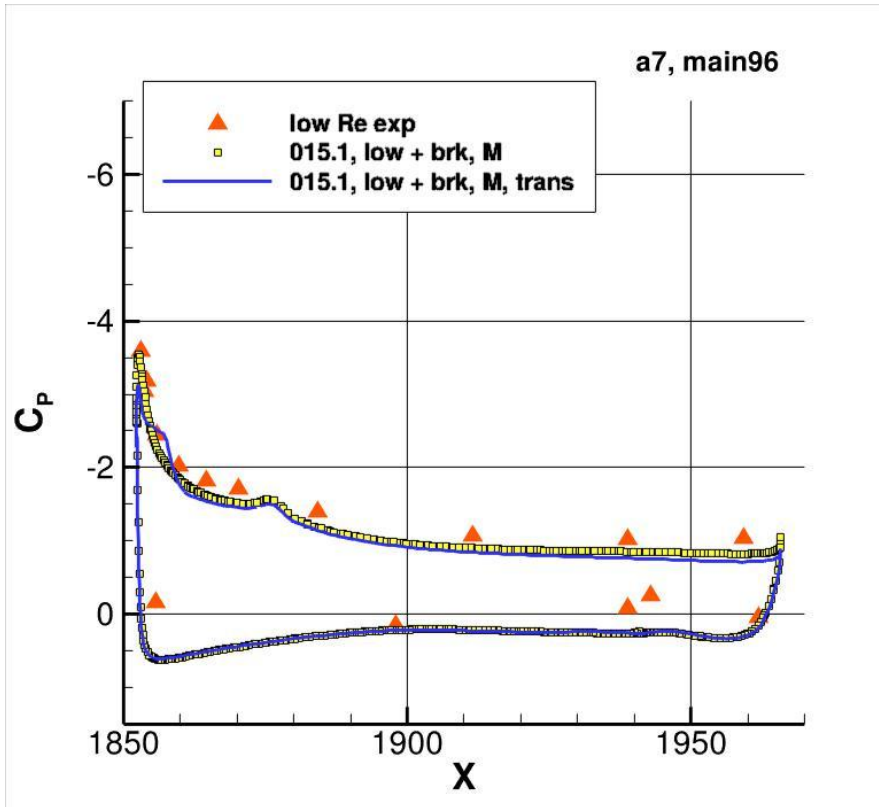

Results with brackets and bundles

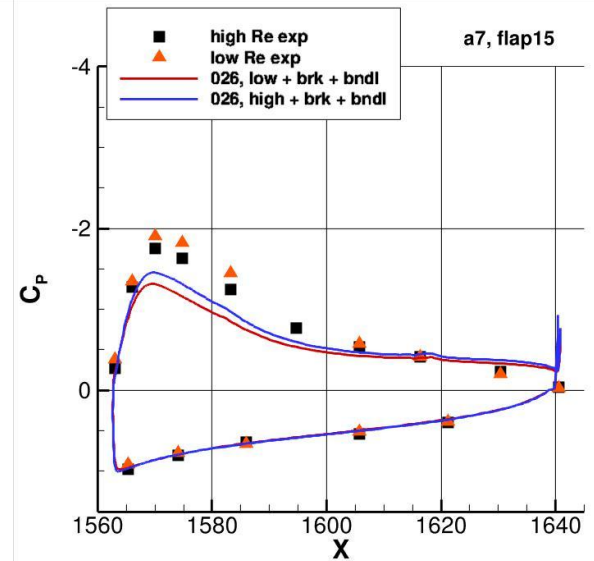
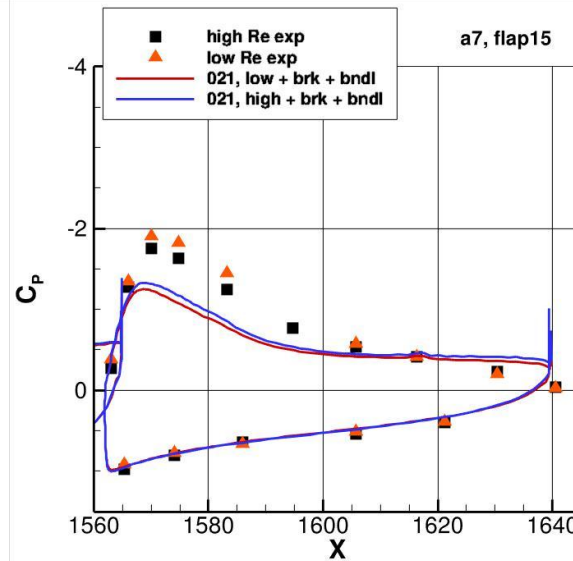
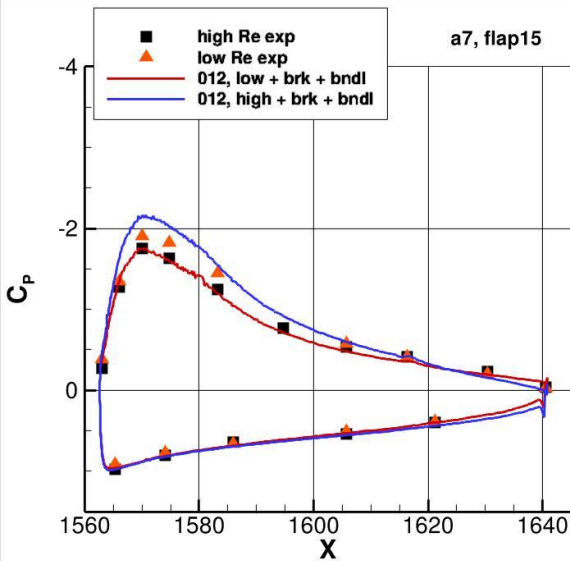

Results cases 1 and 2
(no bundles):

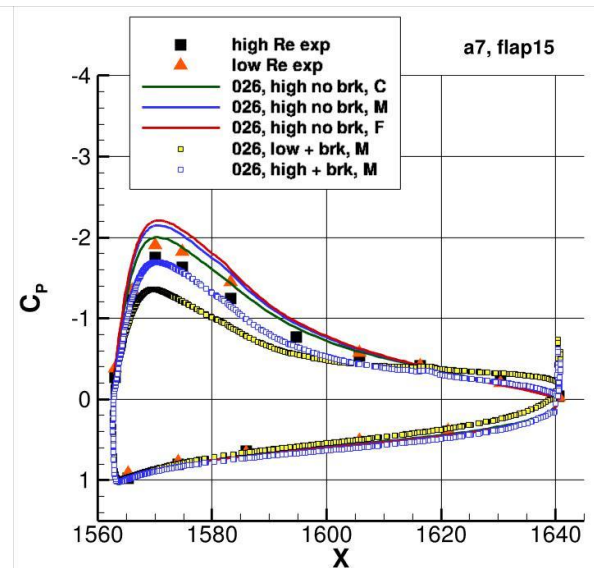
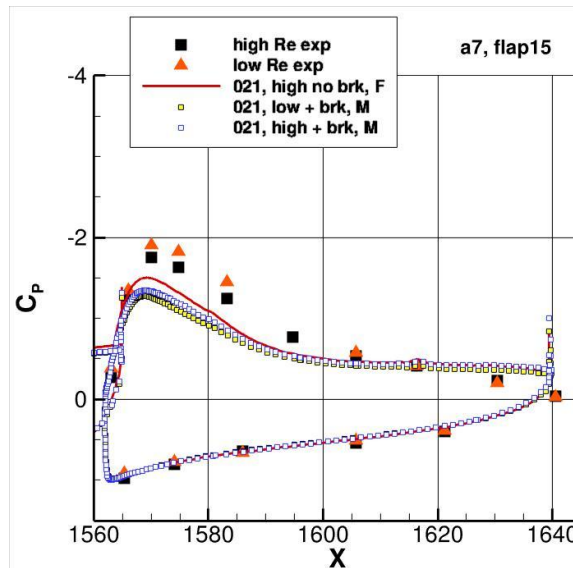

Surface pressure coefficients, AoA=20

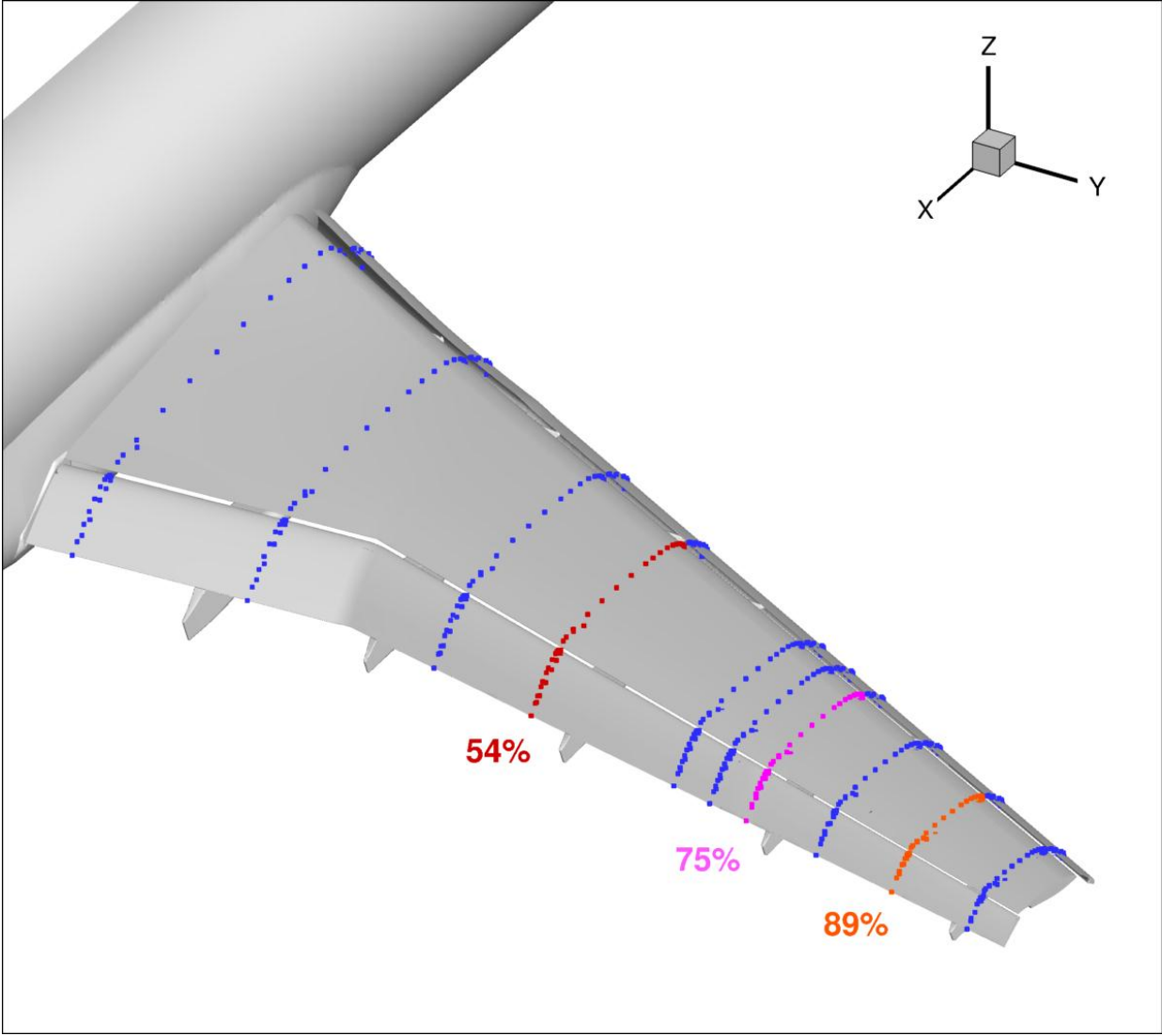

Cps at AoA=20, 54%

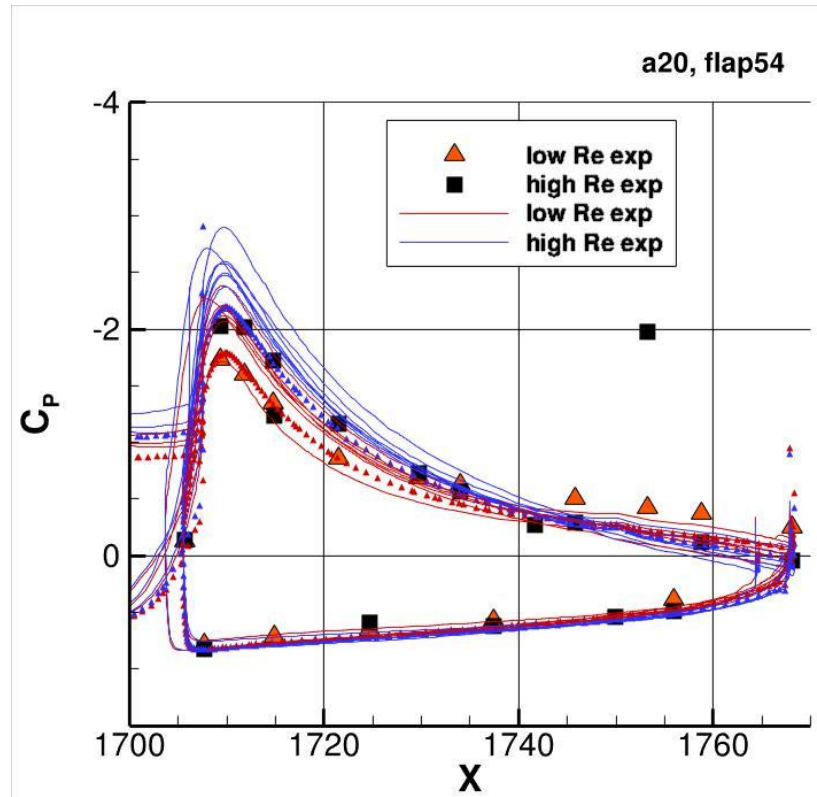
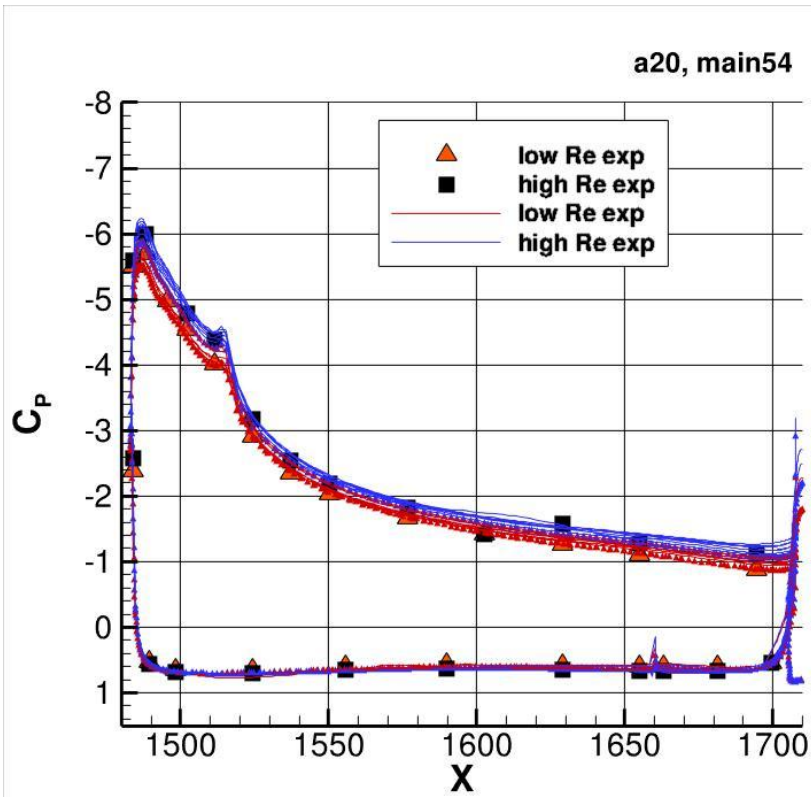

Note: only a sampling of CFD solutions w brackets taken

Cps at AoA=20, 75%

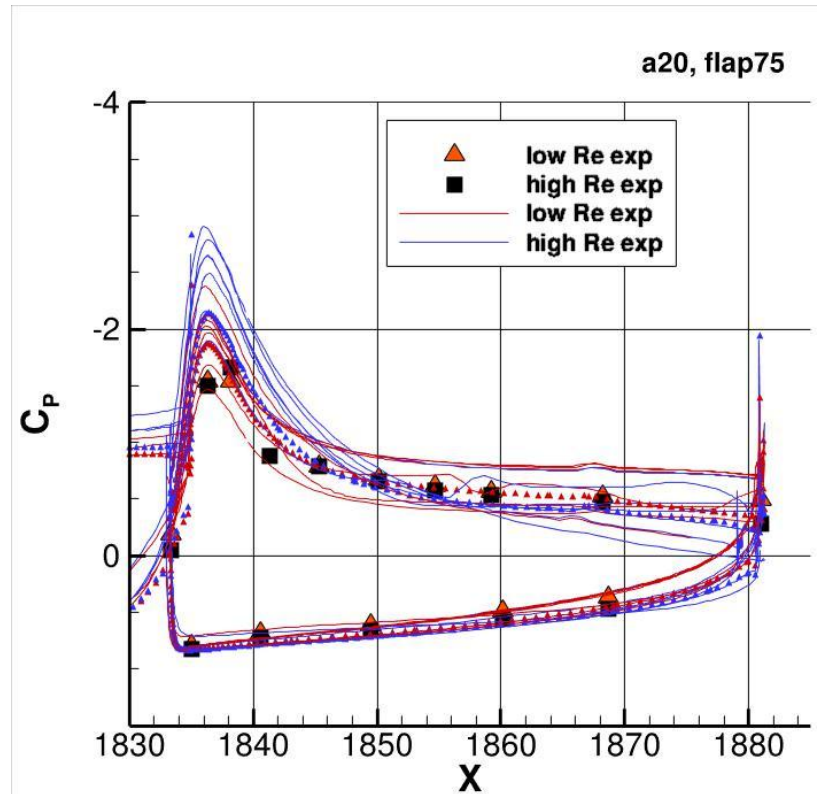
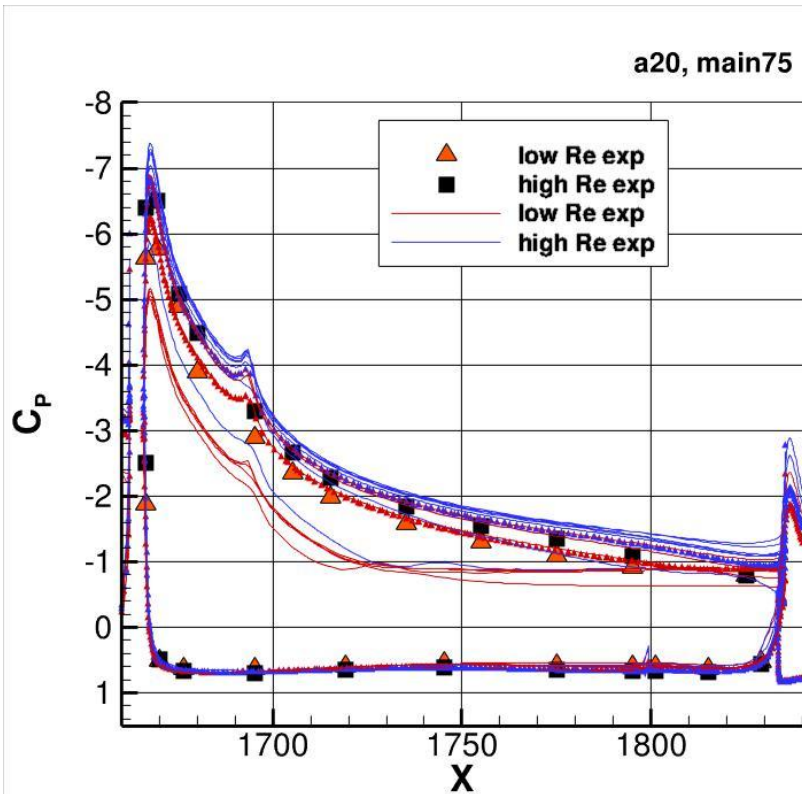

Note: only a sampling of CFD solutions w brackets taken

Cps at AoA=20, 89%

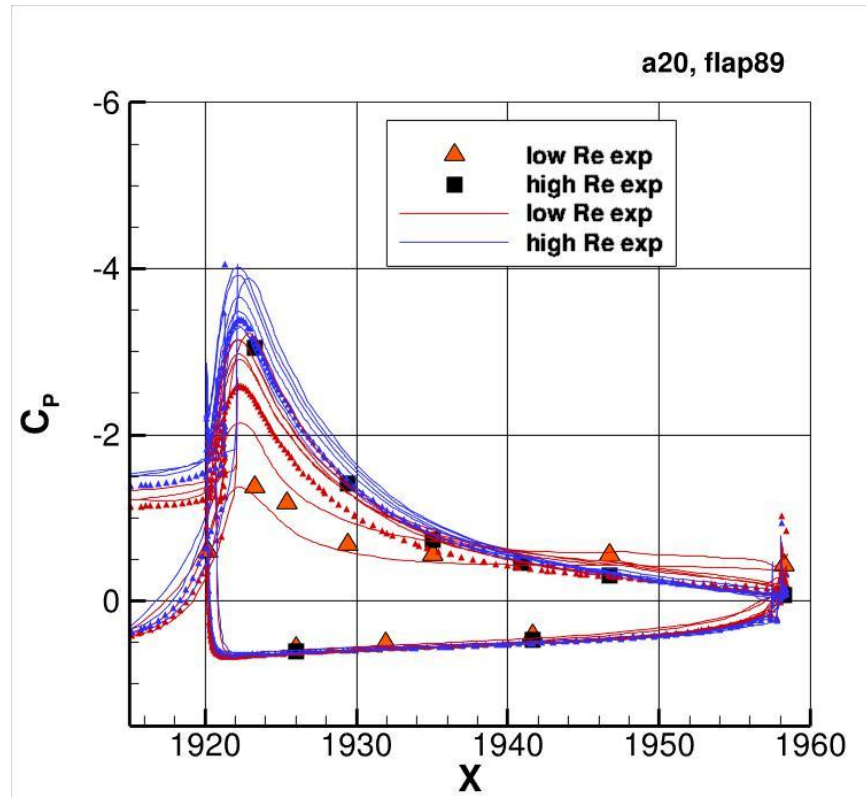
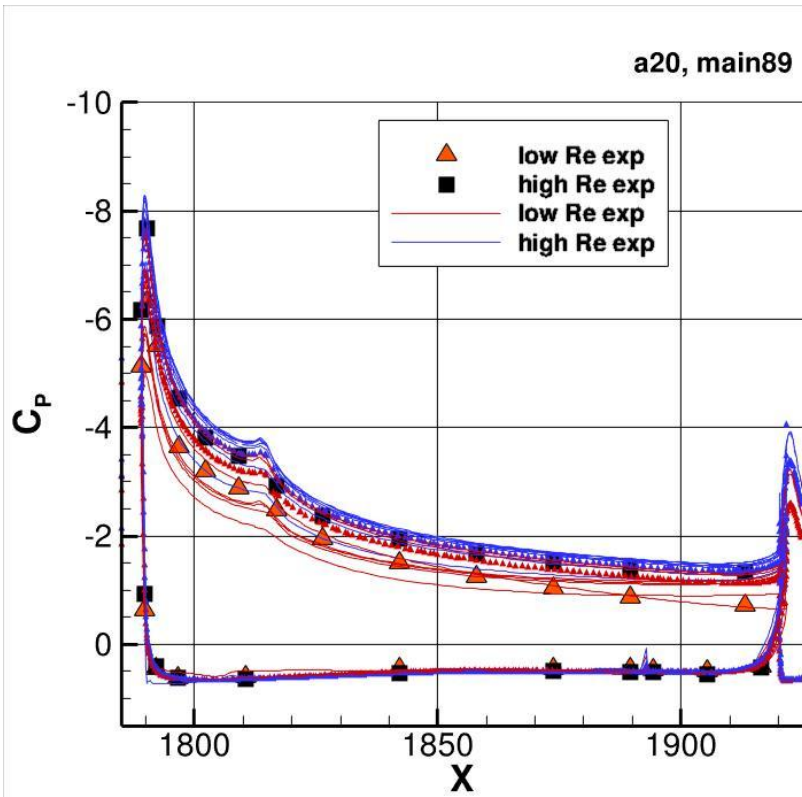

Note: only a sampling of CFD solutions w brackets taken

Force/moment statistics

- Used basic method from DPW (see AIAA 2010-4673)
- Limits $\hat{\mu} \pm K\hat{\sigma}$
 - $\hat{\mu}$ = median of sorted data
 - $\hat{\sigma}$ = sample standard deviation
 - $K = \sqrt{3}$ = coverage factor
- Coefficient of variation $Cv = \hat{\sigma} / \hat{\mu}$
- Analysis only done for AoA=7 and 16

Case 1 C_L statistics, AoA=7

COARSE

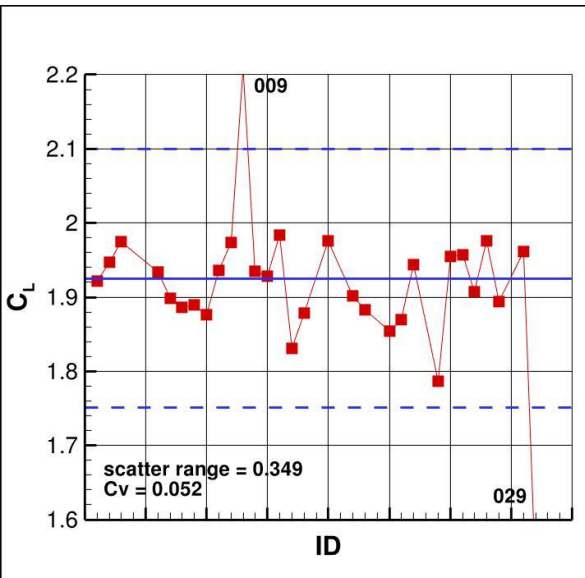

MEDIUM

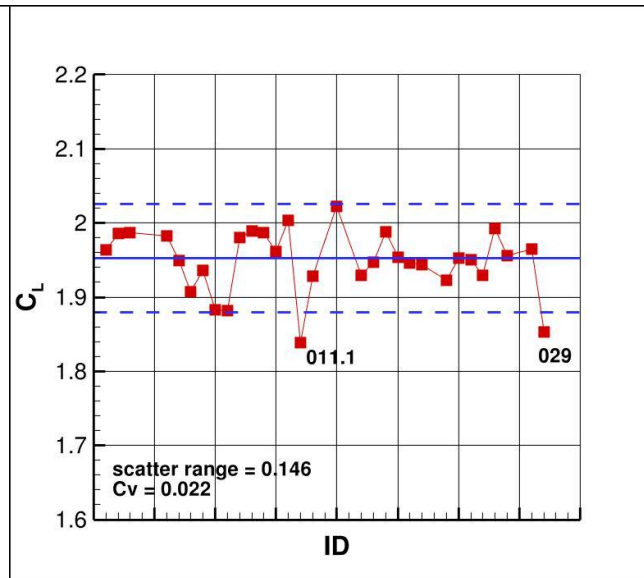

FINE

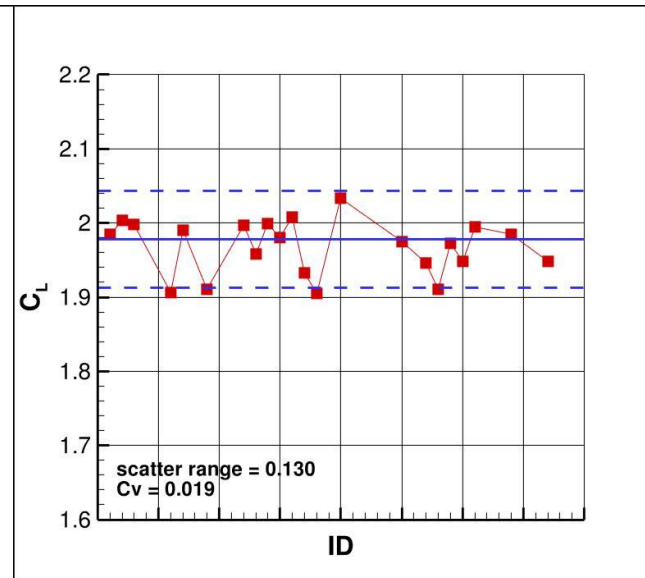

Scatter range decreases as grid is refined

Case 1 C_D statistics, AoA=7

COARSE

MEDIUM

FINE

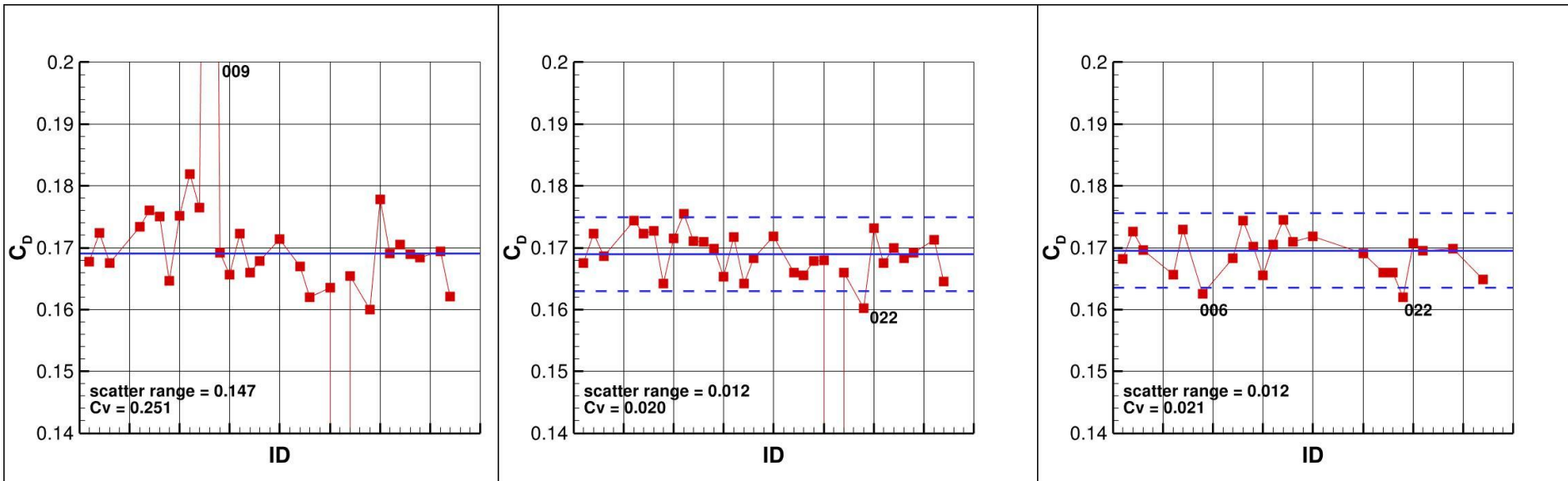

Scatter range is the same on medium and fine grids

Case 1 C_M statistics, AoA=7

COARSE

MEDIUM

FINE

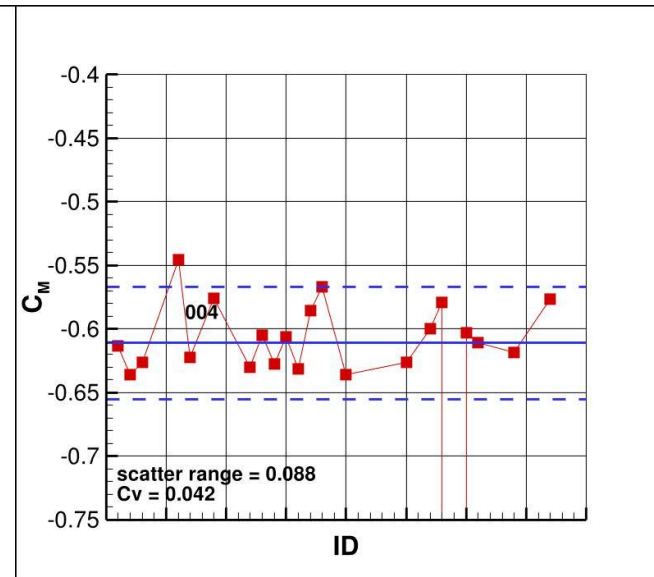
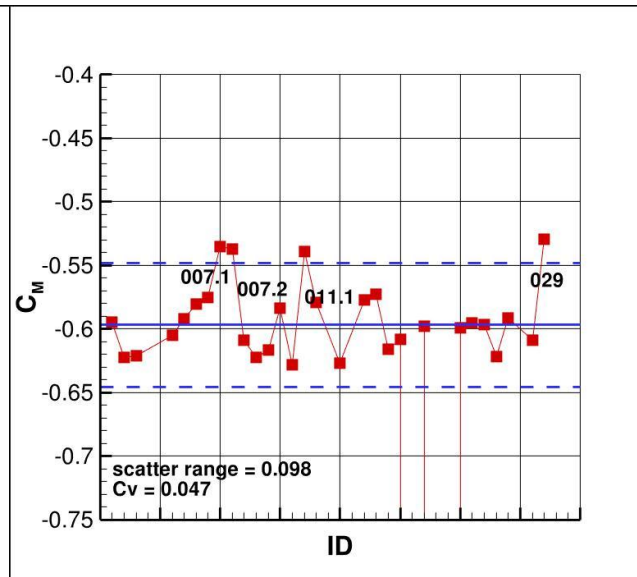
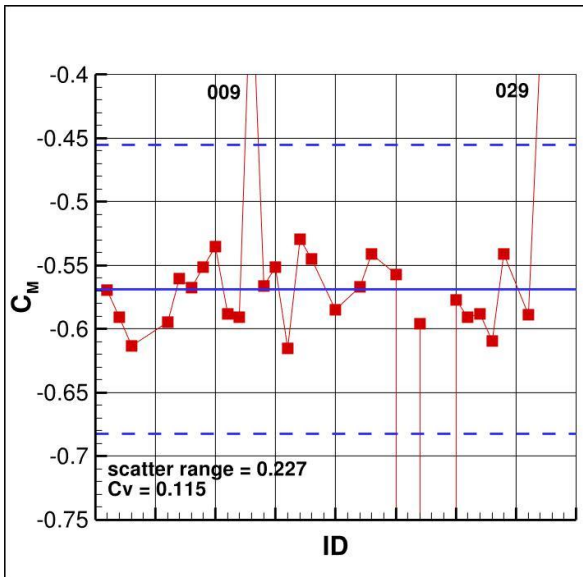

Scatter range decreases as grid is refined

Case 1 C_L statistics, AoA=16

COARSE

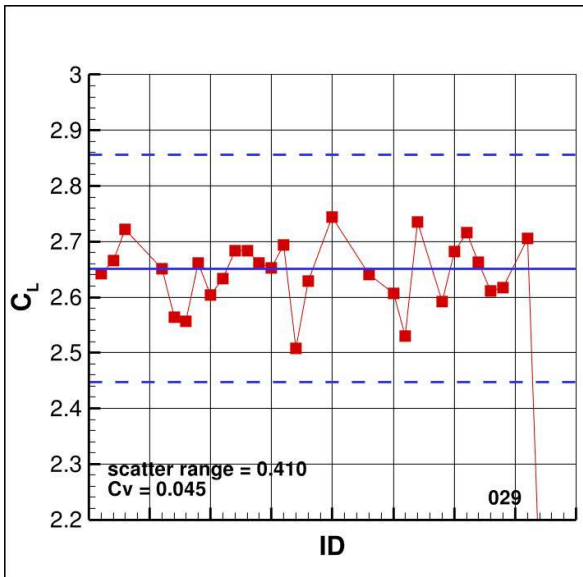

MEDIUM

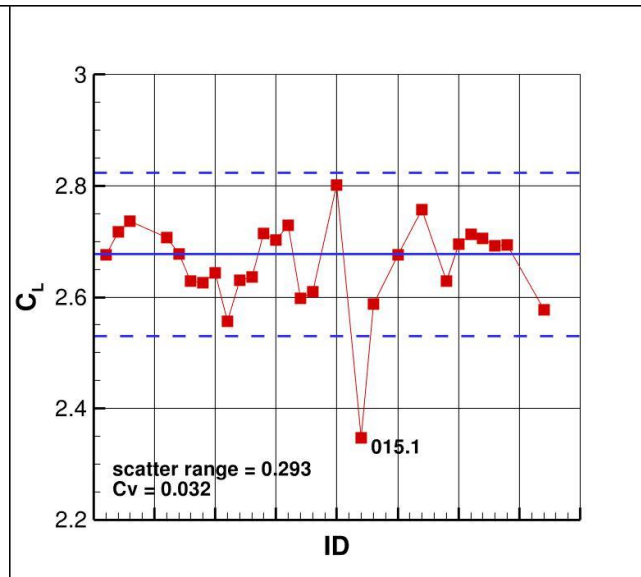

FINE

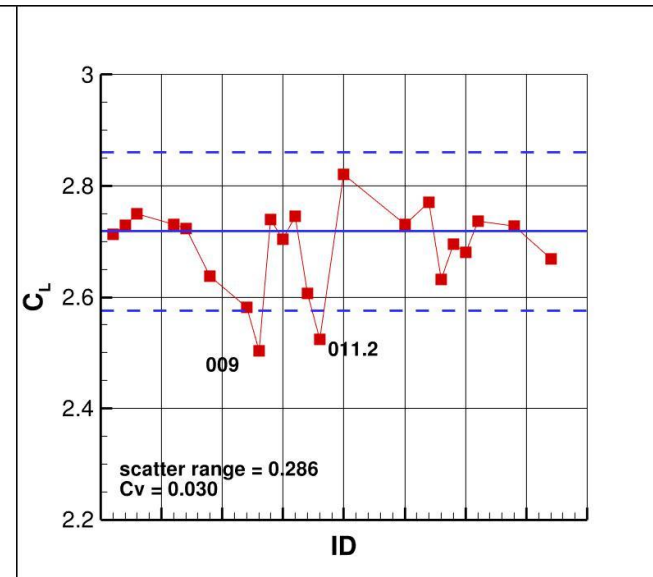

Scatter range decreases (barely) as grid is refined

Case 1 C_D statistics, AoA=16

COARSE

MEDIUM

FINE

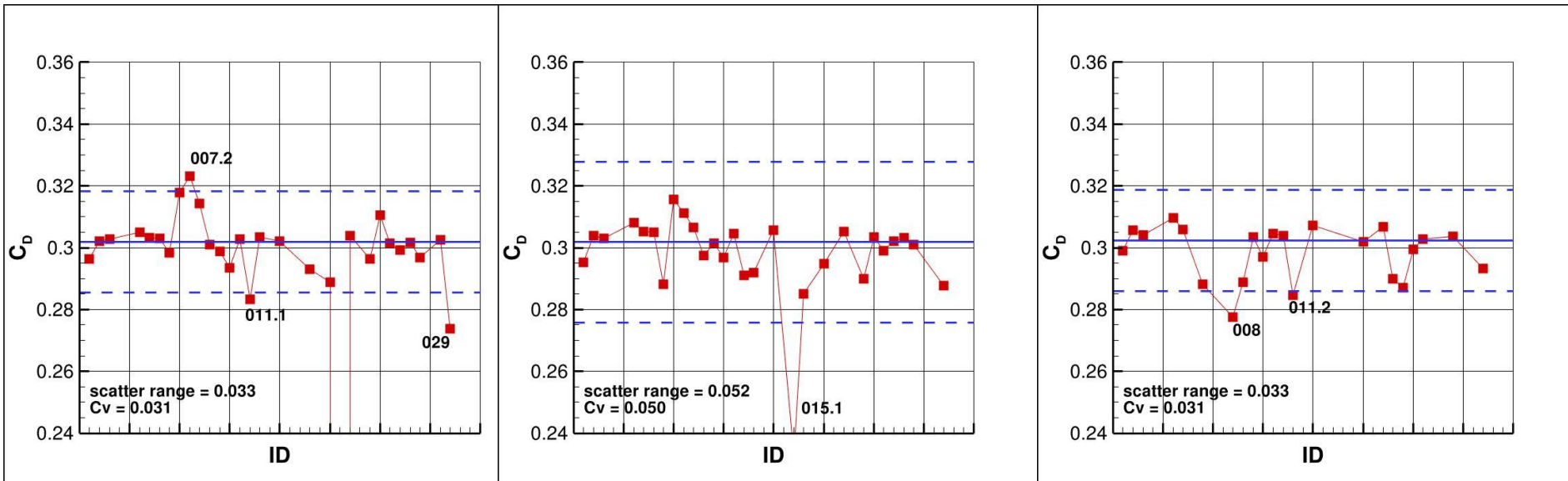

Scatter range on coarse & fine grids is the same

Case 1 C_M statistics, AoA=16

COARSE

MEDIUM

FINE

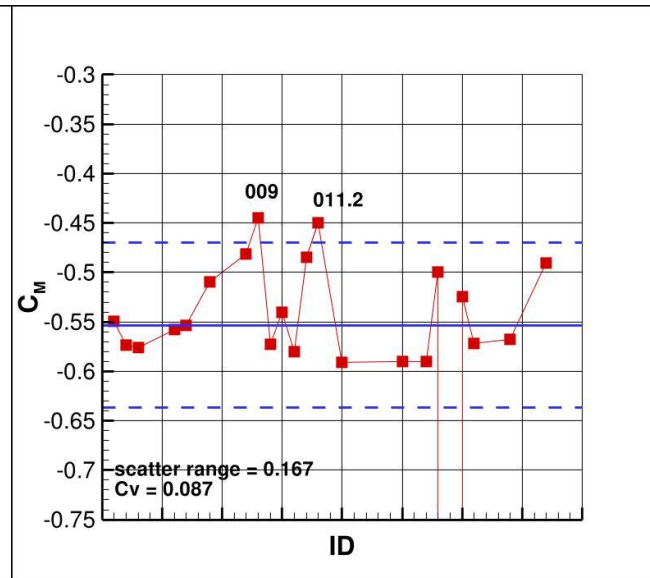
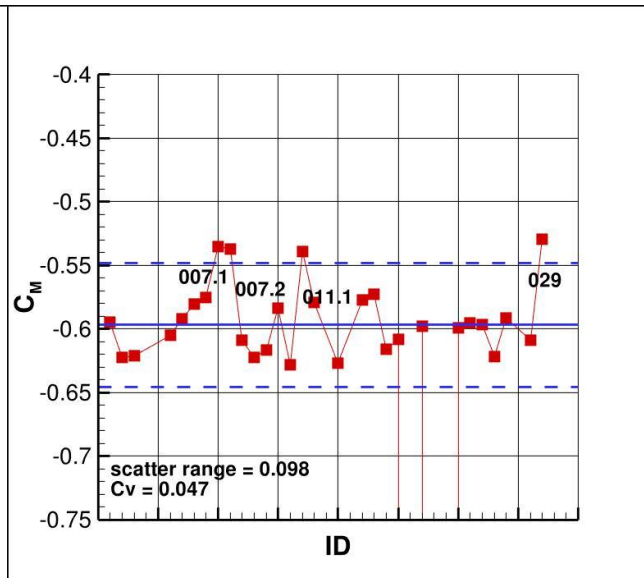
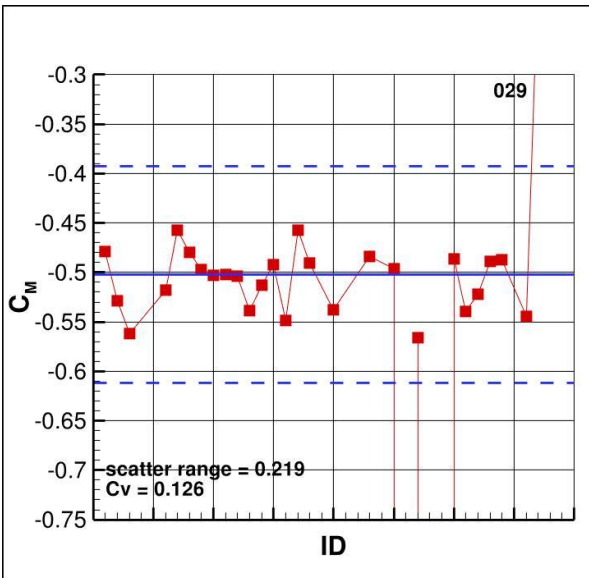

Scatter range gets worse on fine grids

Coefficient of variation summary

Case	Cv for lift	Cv for drag	Cv for moment
DPW II & III	n/a	0.02 – 0.025	0.045 – 0.06
DPW IV	n/a	0.022	0.157
HLPW1, a=13	0.014	0.021	0.031
HLPW1, a=28	0.017	0.020	0.049
Case 1, Alpha=7	0.019	0.021	0.042
Case 1, Alpha=16	0.030	0.031	0.087

Case 1 C_M coefficient of variation

LIFT

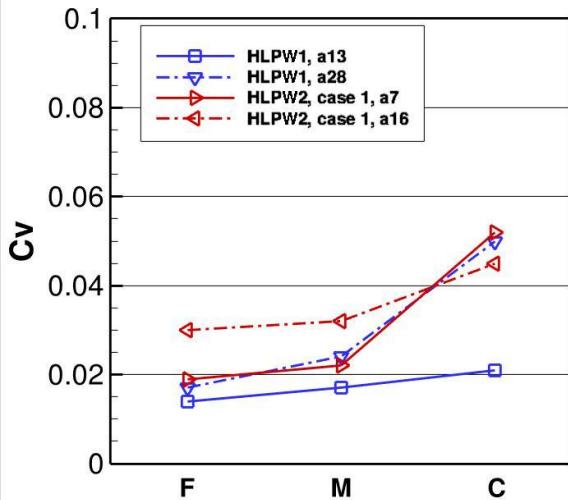

DRAG

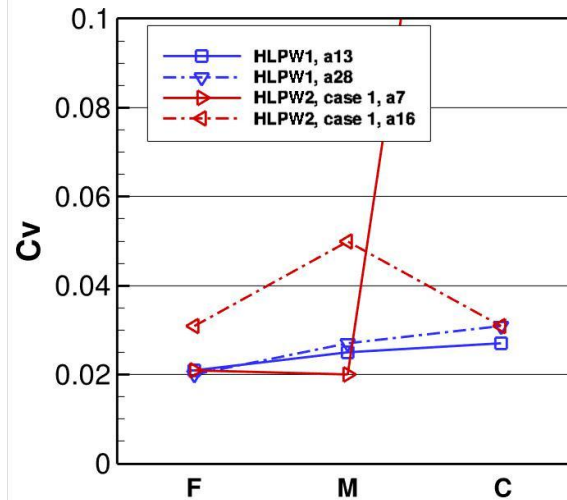

MOMENT

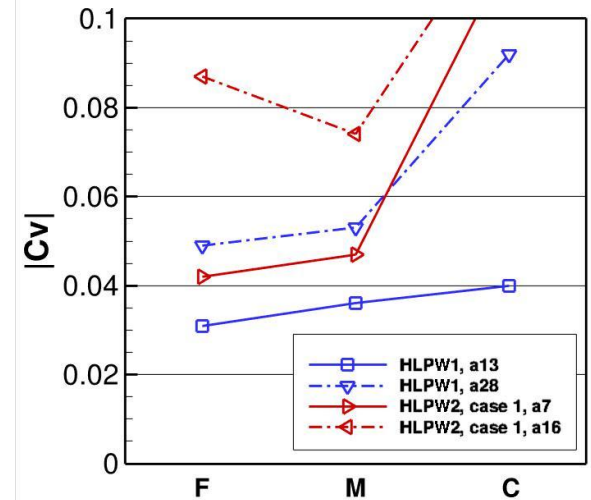

Cv's somewhat higher than HiLiftPW-1

Case 2a/b C_L statistics, AoA=7

Low Re

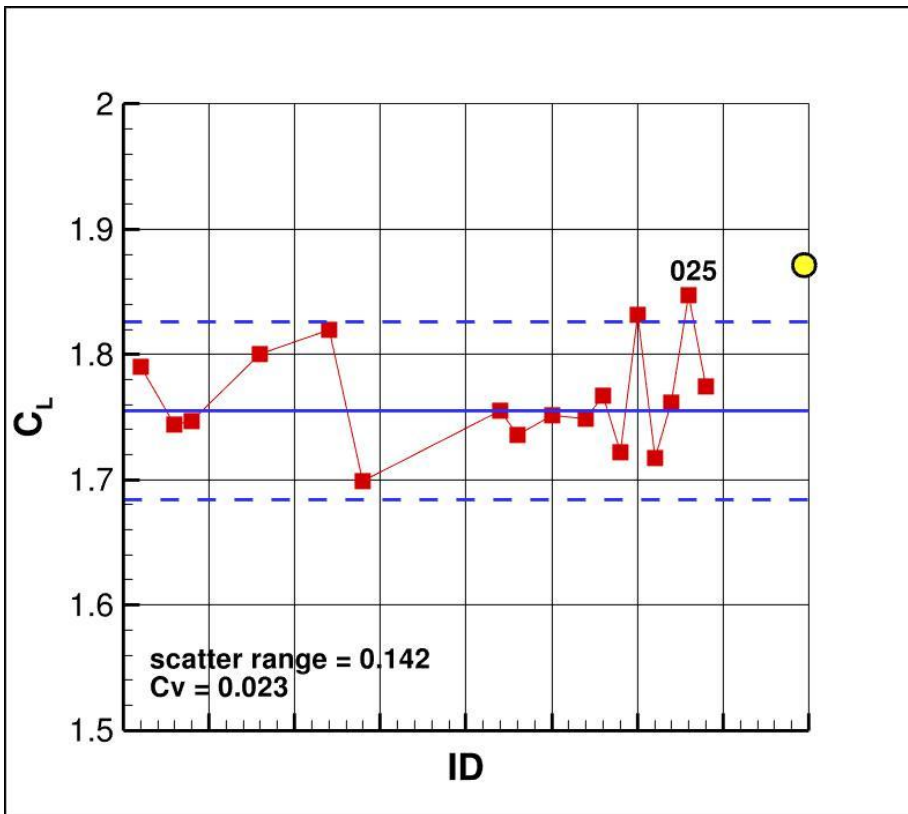

High Re

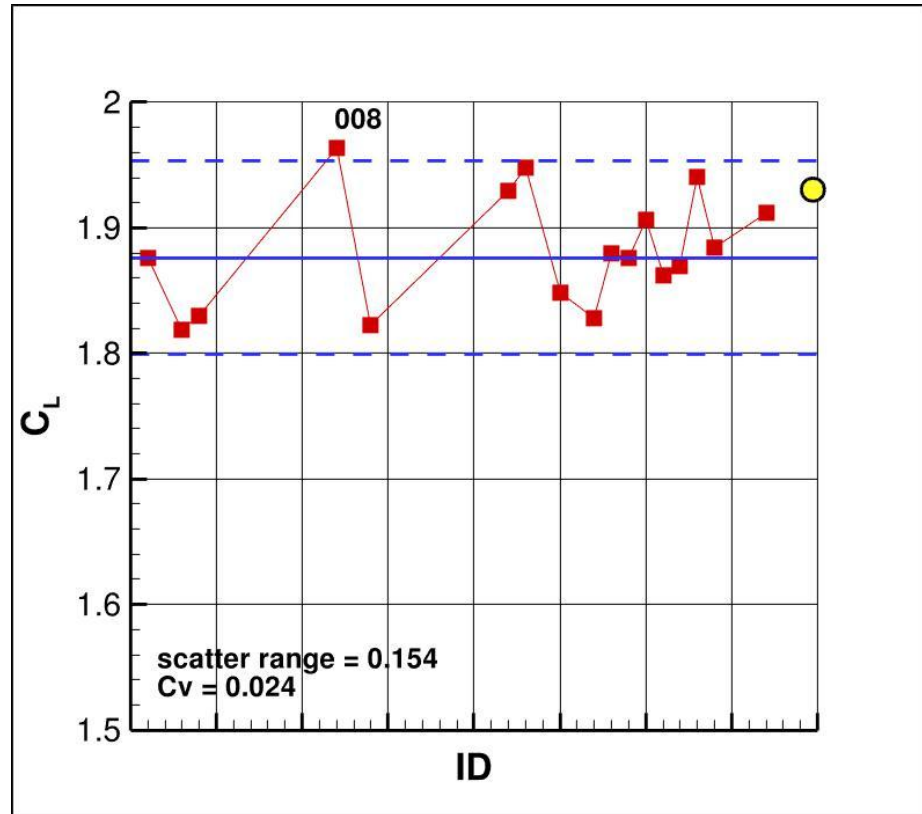

Low Re lift predicted too low

Case 2a/b C_L statistics, AoA=16

Low Re

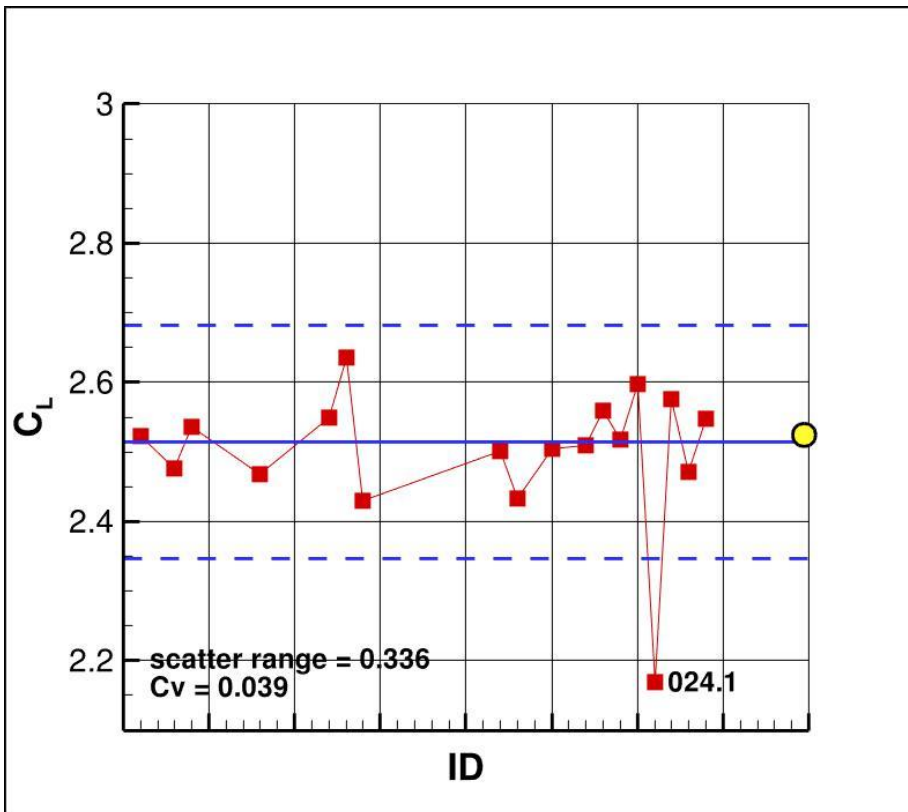

High Re

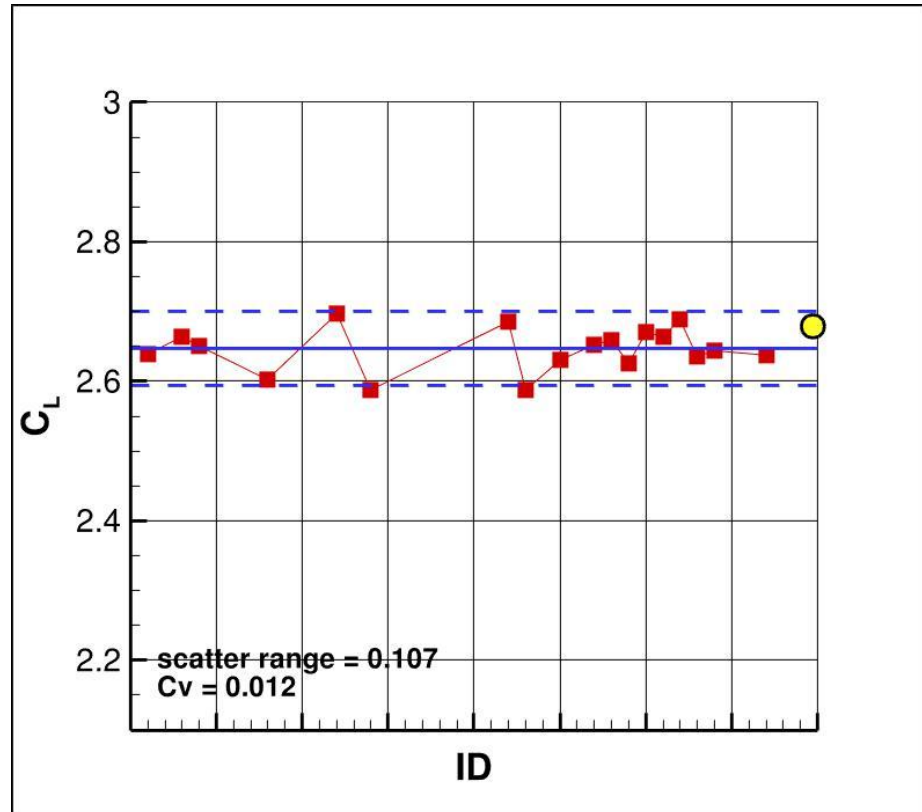

Re levels and trend captured well

Case 2 Reynolds number effect

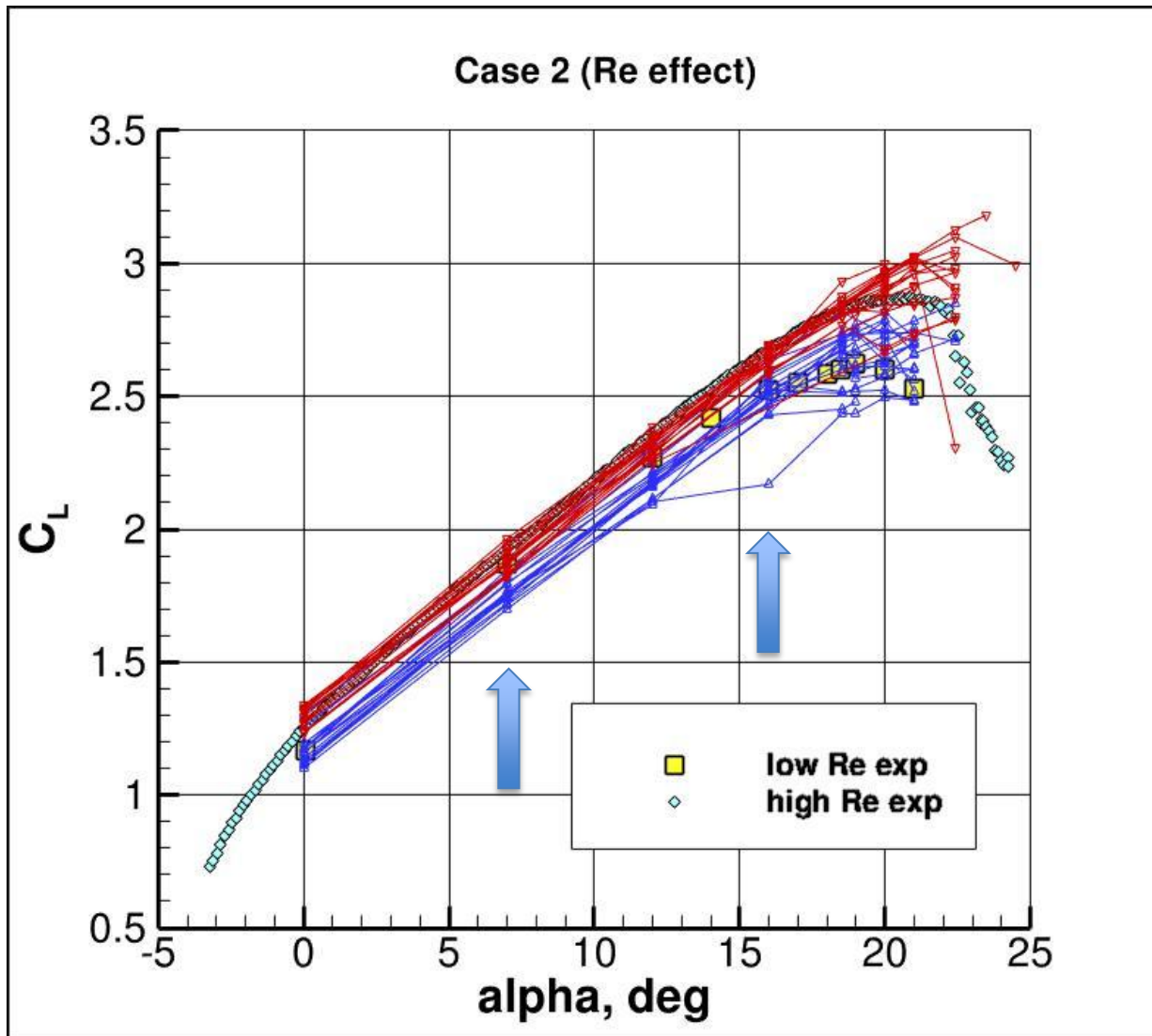

Case 2a/b C_D statistics, AoA=16

Low Re

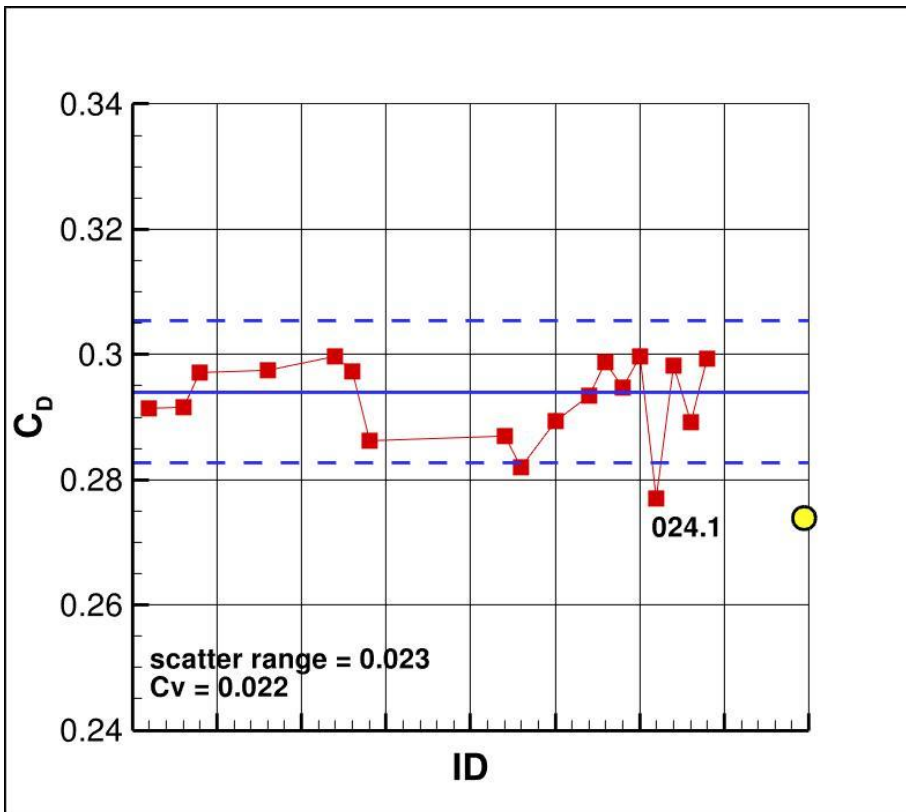

High Re

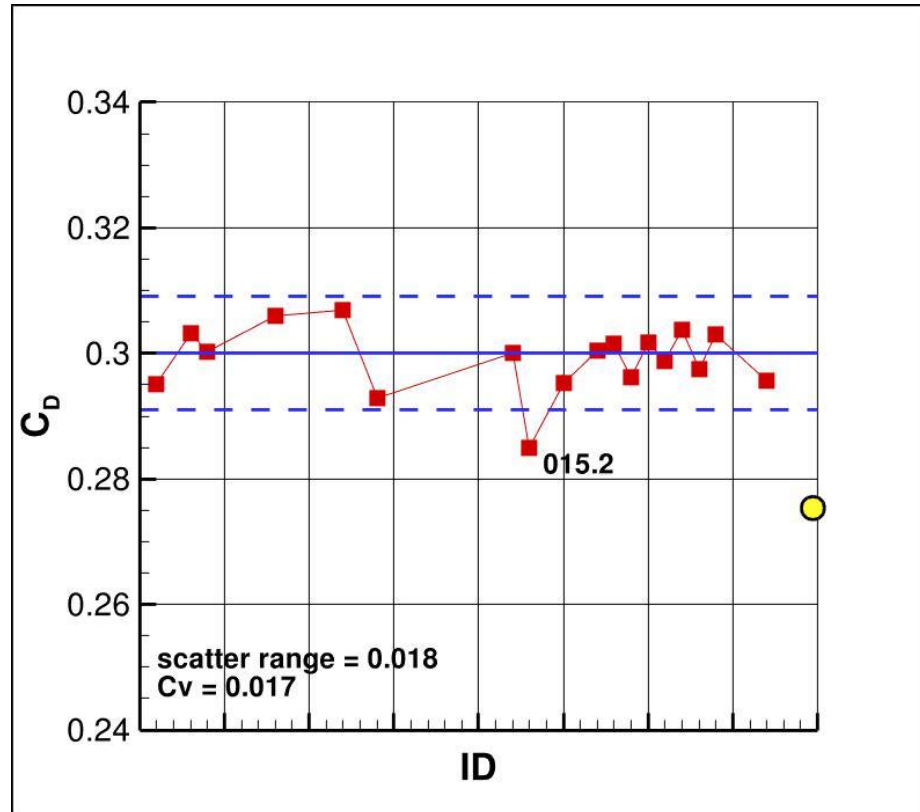

Drag computed too high

Case 2a/b C_M statistics, AoA=16

Low Re

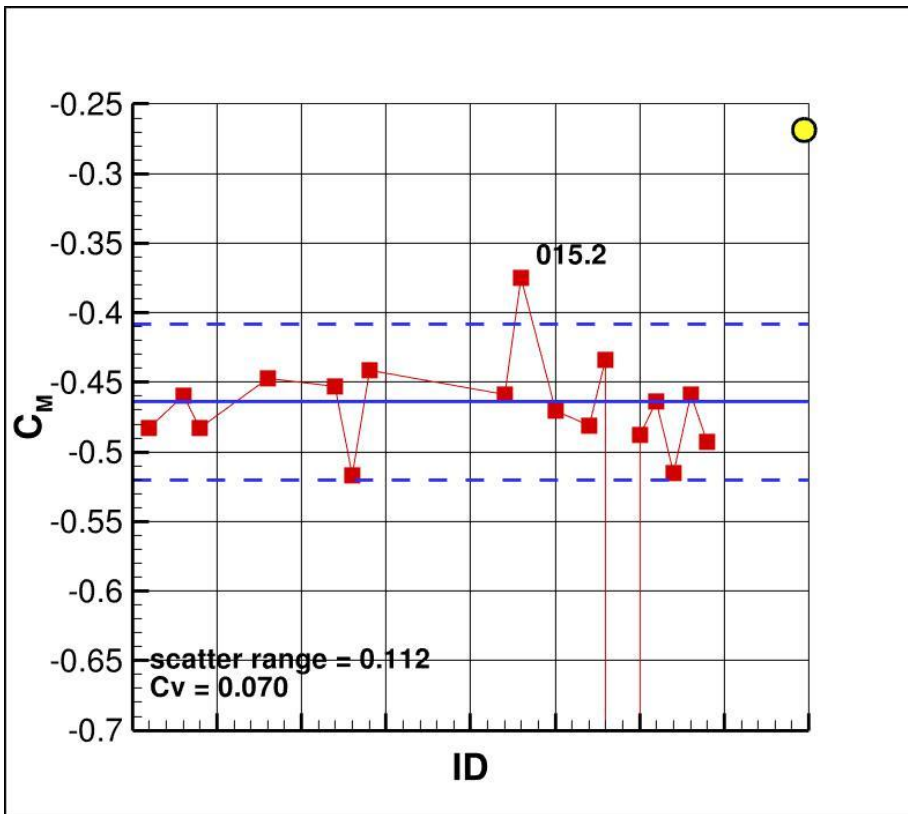

High Re

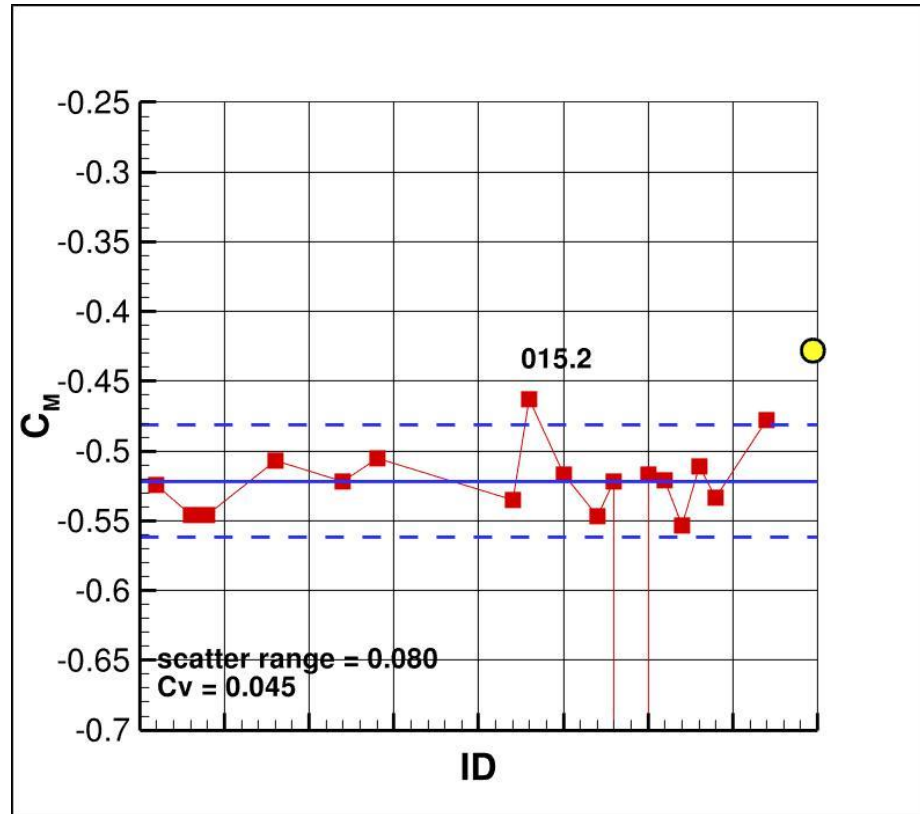

Moment computed too negative
(pitch down)

Summary

- Only two participants performed Case 4 turb model verification
 - SA: very close to website results, but not perfect
 - PANS: looks reasonable (no other code with same model to compare to)
- High lift grid-convergence trends: only so-so
 - Coefficient of variations somewhat higher than previous workshops
- Velocity profiles show that structured grids usually capture wakes better
 - Exception: Unstructured Pointwise Grid C series
- Including brackets clearly important when comparing to experiment
- Importance of transition not clearly established by the results submitted to date
- **Iterative convergence an issue with some submitted results**