

## NASA Near Earth Network (NEN) DVB-S2 Demonstration Testing for Enhancing Higher Data Rates for CubeSat/Small Satellite Missions at X-/Ka-band

Yen Wong, Scott Schaire, Steven Bundick, Peter Fetterer  
 NASA Goddard Space Flight Center  
 Greenbelt, MD 20771, USA; 301-286-7446  
 yen.f.wong@nasa.gov

Trish Perrotto, Peter Celeste  
 Booz Allen Hamilton  
 Annapolis Junction, MD 20701; 301-367-5426  
 perrotto\_trish@bah.com

### ABSTRACT

National Aeronautics and Space Administration (NASA) CubeSat/SmallSat missions are moving to higher data rates. Digital Video Broadcast, Satellite Second Generation (DVB-S2) is a communications standard that uses power and bandwidth efficient modulation and coding techniques to deliver performance approaching radio frequency (RF) channel theoretical limits. The Near Earth Network (NEN) will test DVB-S2's ability to provide higher data rates for CubeSat/SmallSat missions at X-band and Ka-band at Wallops Flight Facility (WFF). The goal is to upgrade the NEN with DVB-S2 to increase science data return for missions and enable support for more CubeSat/SmallSat missions.

This paper describes NEN DVB-S2 X-band and Ka-band demonstration objectives, scope, and performance measures as well as NEN channel test configuration. The NEN has planned 2020 tests to demonstrate all modulation and coding schemes in the Consultative Committee for Space Data Systems (CCSDS) DVB-S2 standard over X-band and Ka-band. A link analysis study for the trade-offs among achievable data rates, modulations, codes, spacecraft antenna sizes and power amplifiers (PA) is provided. This paper identifies Commercial off-the-shelf (COTS) CubeSat/SmallSat X-band and Ka-band communication systems and discusses low cost DVB-S2 X-band software defined radio (SDR) transmitter development concepts and implementation with a practical system for CubeSats/SmallSats.

### 1.0 INTRODUCTION

Given the 5 MHz bandwidth allocation for NASA missions at S-band, which limits the achievable data rate, the use of X-band with 375 MHz bandwidth and Ka-band with 1.5 GHz bandwidth enables a higher data rate solution for the CubeSat/SmallSat community.

In 2016, Syrlinks wrote a paper for the Small Satellite Conference, "X-band Transmission Evolution toward DVB-S2 for Small Satellites".<sup>1</sup> It stated that National Centre for Space Studies (CNES) was upgrading their small satellite radio with Digital Video Broadcast, Satellite Second Generation (DVB-S2). The expected improvement was a 60% increase in downloaded data; a link budget increase of about 2 dB, and improved spectral efficiency. Analysis performed by the NASA Near Earth Network (NEN) shows significant potential increases in data rates for X-band and Ka-band, and increased energy and spectral efficiency with DVB-S2.

It is a wonder that DVB-S2 is not more widely used for missions. Using DVB-S2, the potential is for 1 Gbps over X-band and 2.2 Gbps over Ka-band with today's NEN ground station receivers.

NASA flies SmallSats for Earth, heliophysics, astrophysics, and planetary science and for space technology advancement. NASA's Goddard Space Flight Center (GSFC) continues to study methods to provide the highest data rate communication from the longest distance from Earth with the lowest size, weight and power (SWaP) for NASA spacecraft to maximize the science and technology advancement return.

In 2019, NASA's NEN conducted a DVB-S2 demonstration, testing 15 Mbps over the NEN's 5 MHz channel at the Wallops Flight Facility (WFF). DVB-S2 is a family of modulations and codes for maximizing data rate and minimizing bandwidth use and SWaP.<sup>2</sup>

DVB-S2 uses power and bandwidth efficient modulation and coding (MODCODE) techniques to deliver performance approaching theoretical limits of radio frequency (RF) channels. In 2020, NEN analyzed and planned to test higher data rates over X-band and Ka-band. The results are valuable to the SmallSat user community for the planning of higher data rate missions.

Section 4 of this paper describes the demonstration objectives and scope. Section 6 describes the performance measurements and planned test configuration. Section 9 discusses a low-cost DVB-S2 X-band software designed radio (SDR) transmitter development concept and implementation with practical systems.

## 2.0 NEN OVERVIEW

The NEN provides direct-to-earth telemetry, commanding, ground-based tracking, and data and communications services to a wide range of customers.

The NASA NEN project consists of NASA, commercial, and partner S-band, X-band, and Ka-band ground stations supporting spacecraft in low Earth orbit (LEO), geostationary Earth orbit (GEO), highly elliptical orbit (HEO), lunar orbit, and Lagrange Point L1/L2 orbit up to one million miles from Earth.

Figure 1 is a diagram of the NEN' global infrastructure. The NEN supports multiple science, exploration, robotic and launch vehicle missions with NASA-owned stations and through cooperative agreements with interagency, international, and commercial services.<sup>3</sup> The NEN is adding additional Ka-band capability, and recently added two 6.1-meter S-band ground stations in Florida. The Ka-band and Florida ground stations augment NEN SmallSat orbital tracking and communications capacity. Table 1 shows the supported radio frequencies managed by the National Telecommunications and Information Administration (NTIA) and supported by the NEN..



**Figure 1 NASA NEN (Direct to Earth Coverage up to one million miles from Earth)**

Higher data rates either increase science return or reduce the number of minutes per day of ground station contact required. Reducing the number of minutes per day increases the number of SmallSat spacecraft that the NEN could accommodate with its existing ground stations. Higher data rates also enable mother-daughter SmallSat constellations, where the mother spacecraft handles the communication with Earth for multiple daughter spacecraft.

**Table 1 NEN Frequencies and Bandwidths for NTIA Licensing**

Band	Function	Freq. Band (MHz)	Bandwidth (MHz)	Maximum Bandwidth per Transmitter (MHz)
S Uplink	Earth to Space	2,025--2,110	85	Typically <5
X Uplink	Earth to Space	7,190--7,235 (Two NEN sites to 7,200)	10	Typically <5
S Downlink	Space to Earth	2,200--2,290	90	5
X Downlink	Space to Earth, Earth Exploration	8,025--8,400	375	375
X Downlink	Space to Earth, Space Research	8,450--8,500	50	10
Ka Downlink	Space to Earth	25,00 – 27,000	1,500	1,500

### 3.0 DVB-S2 OVERVIEW

DVB-S2 has become a significant industry satellite communications standard.<sup>2</sup> The NEN is interested in exploring upgrade to the NEN with the current state of practice. The DVB-S2 framing structure allows for maximum flexibility in a versatile system and synchronization under low signal-to-noise ratio (SNR). The adaptive coding and modulation features allow for optimization of transmission parameters for each individual user.

The DVB-S2 transmission system consists of five major Subsystems/Blocks:

- “Mode & Stream Adaption” Block
- “FEC Encoding” Block
- “Mapping” Block
- “Physical Layer (PL) Framing” Block
- “Modulation” Block

Figure 2 illustrates the DVB-S2 subsystem block structure.

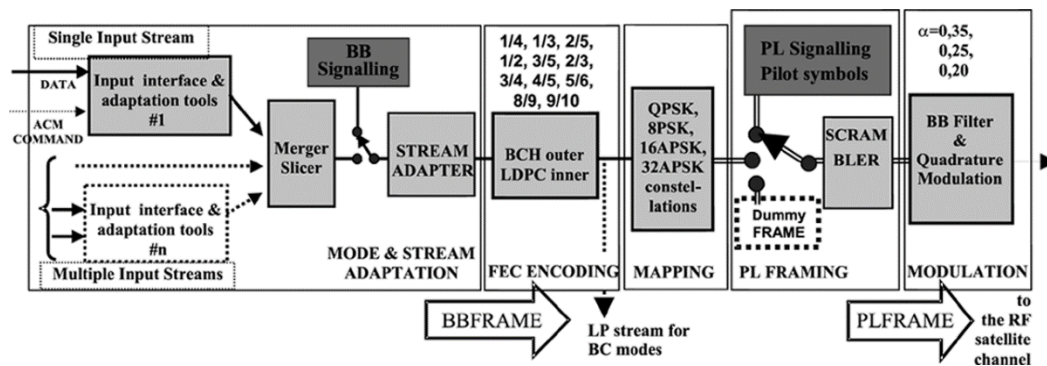

**Figure 2 DVB-S2 Transmission System Block Structure**

### 3.1 DVB-S2 Modulation & Coding

DVB-S2 defines a large number of modulation formats and coding rate combination options:

- Modulation Schemes include: QPSK, 8PSK, 16APSK, and 32APSK
- Inner code: Low Density Parity Check (LDPC)
- Outer Code: Bose-Chaudhuri-Hocquenghem (BCH)

Table 2 summarizes DVB-S2 modulation and coding schemes.

**Table 2 DVB-S2 Modulation & Coding Schemes**

Modulation Schemes	LDPC Coding Rates
QPSK	1/4, 1/3, 2/5, 1/2, 3/5, 2/3, 3/4, 4/5, 5/6, 8/9, 9/10
8PSK	3/5, 2/3, 3/4, 5/6, 8/9, 9/10
16 APSK	2/3, 3/4, 4/5, 5/6, 8/9, 9/10
32 APSK	3/4, 4/5, 5/6, 8/9, 9/10

### 3.2 DVB-S2 General Characteristics

DVB-S2 general characteristics include:

- Baseband (BB) Filtering: I/Q symbol square root raised cosine filter (SRRC) with roll-off factors of 0.35, 0.25, or 0.20
- Bit interleaving applied to Forward Error Correction (FEC) for 8PSK, 16APSK, and 32APSK
- Randomization
- Optional pilot symbols to facilitate receiver synchronization
- Baseband frames choice of:
  - 64,800 bits
  - 16,200 bits

- Very low SNRs with the DVB-S2 signal: Phase Noise could result in carrier tracking loop cycle slips and symbol synchronizer slips.
- More stringent NEN user phase noise and symbol jitter constraints could reduce the possibility of cycle slips and symbol slips.

### 3.3 DVB-S2 and NEN Channel Distortion

NASA successfully conducted a test at WFF in spring of 2019 to demonstrate the use of DVB-S2 for data rates up to 15 Mbps over a 5 MHz S-band channel<sup>4</sup>. The S-band results of mild implementation loss for the bit error rate (BER) test indicate that the nonlinearly and phase noise in the NEN medium loop configuration are not serious.

### 3.4 DVB-S2 and NEN Operations

Today, for downlink, NEN distributes frames and files of data from the spacecraft; housekeeping and science data processing is typically performed at customers' mission operation centers or facilities. The NEN expects to support DVB-S2 customers similarly to how the NEN currently supports other customers today. The spacecraft using DVB-S2 implements all the blocks in Figure 2. The NEN demodulates, decodes and synchronizes frames of data from the spacecraft.

### 4.0 NEN X/KA-BAND DVB-S2 DEMONSTRATION TESTING OBJECTIVES AND SCOPE

Scope: Perform demonstration testing of DVB-S2 signal BER performance over NEN X-band and Ka-band channels.

Objectives:

1. Determine the performance of the DVB-S2 signal and the maximum achievable data rate over the NEN X-band 375 MHz and Ka-band 1.5 GHz channels. The performance was evaluated for  $BER \leq 10^{-7}$ .
2. Collect Eb/No versus BER data and signal spectra for NEN medium loop configurations.
3. Determine implementation loss at various BER points by using collected Eb/No versus BER data.

The maximum achievable data rate depends on the modulation and coding schemes, channel bandwidth and ground station receiver capability. Table 2 lists the modulation and coding schemes used in the demonstration test. Currently, the NEN station receiver maximum symbol rate is limited to 500 Msps for DVB-S2 mode.

**5.0 PREDICTED DVB-S2 HIGH DATA RATE PERFORMANCE OVER NEN X BAND 375 MZ AND KA-BAND 1.5 GHZ AWGN CHANNEL WITH TODAY'S NEN STATION RECEIVER CAPABILITY**

Given the bandwidths of the NEN X-band 375 MHz channel and the NEN Ka-band 1.5 GHz channel, what are the maximum achievable data rates for the variety of modulation and coding schemes in DVB-S2 signal family?

Analysis was performed to predict the maximum achievable data rates, based on DVB-S2 spectral efficiency and performance requirements specified in ETSI EN 302 307-1 V1.4.1, Table 13 and CCSDS 131.3-B-1, Annex D.<sup>5,6,7.</sup>

Today, the maximum symbol rate of a NEN station Cortex high data rate receiver (HDR) is 500 Msps for DVB-S2 mode. This is the maximum channel symbol rate for NEN X-band and Ka-band channels with a DVB-S2 signal. This limitation takes into account the achievable data rate prediction. Note that the prediction is for intermediate frequency (IF) loop back, pilots off, and additive white Gaussian noise (AWGN).

*The equations used to calculate the predicated maximum achievable data rates are:*

$$R_m = \eta (R_{cs}) \tag{1}$$

where,  $R_m$  = maximum data rate,  $\eta$  =Spectral efficiency,  $R_{cs}$ = channel symbol rate.

Root raised cosine (RRC) filtering is required by the CCSDS DVB-S2 standard with roll-off factors of 0.35, 0.25 or 0.20.

$$C_{bw} = (1 + \alpha) R_{cs} \tag{2}$$

where,  $C_{bw}$  = occupied channel bandwidth,  $\alpha$  =roll-off factor,  $R_{cs}$  = channel symbol rate.

$$R_m = \eta (C_{bw}) / (1 + \alpha) \tag{3}$$

where,  $R_m$  = maximum data rate,  $\eta$  =Spectral efficiency,  $C_{bw}$ =occupied channel bandwidth,  $\alpha$ =roll-off factor.

In NEN X-band channel of 375 MHz bandwidth, the maximum channel symbol rate is determined by 375/ (1 + roll-off). The maximum channel symbol rate is 300 Msps with the roll-off factor of 0.25. The predicted maximum data rate = spectral efficiency x 300 Msps.

The predicated maximum achievable data rates in the NEN X-band 375 MHz channel are calculated and depicted in Table 3.

In NEN Ka-band 1.5 GHz channel, the predicted maximum channel data rate equals the spectral efficiency times the channel symbol rate. With the 1.5 GHz channel bandwidth, set the channel symbol rate the same as station HDR receiver maximum symbol rate which is 500 Msps,

The predicated maximum achievable data rates in the NEN Ka-band 1.5 GHz channel are calculated and depicted in Table 4.

**Table 3 DVB-S2 Predicted Maximum Data Rate (Mbps) in NEN X-band 375 MHz AWGN Channel**

Mod/Coding Rate	1/4	1/3	2/5	1/2	3/5	2/3	3/4	4/5	5/6	8/9	9/10
<b>QPSK</b>	147	170	236.7	296.6	356.5	396.6	446.2	476.16	496.4	530	536.4
<b>8 PSK</b>					534	594	668.4	N/A	743.4	793.8	803.7
<b>16 PSK</b>						791	890	950	990	1057	1070
<b>32 PSK</b>							1111	1185.5	1235.7	1319	1336

**Table 4 DVB-S2 Predicted Maximum Data Rate (Mbps) in NEN Ka-band 1.5 GHz AWGN Channel**

Mod/Coding Rate	1/4	1/3	2/5	1/2	3/5	2/3	3/4	4/5	5/6	8/9	9/10
<b>QPSK</b>	245	328	394.7	494.4	594.5	661	743.7	793.5	827.3	883.3	894.3
<b>8 PSK</b>					890	990	1114	N/A	1239	1323	1340
<b>16 PSK</b>						1318.5	1483	1582.8	1650	1761.5	1783.5
<b>32 PSK</b>							1850	1975.8	2059.5	2219	2226

**6.0 DEMONSTRATION TEST DESCRIPTION AND CONFIGURATIONS**

The demonstration test was conducted with a Zodiac HDR DVB-S2 demonstration license that contained a test modulator and receiver. Figure 3 depicts the demonstration test configuration at X-band. Figure 4 depicts the demonstration test configuration at Ka-band-band. The test modulator, up-converter, low noise amplifier (LNA), and the down-converter emulate the NEN medium loop configuration.

During the medium loop test, the DVB-S2 signal generated by the test modulator at 720 MHz was up-converted to the frequency of 8250 MHz for X-band and 2.60 GHz at Ka-band. The 8250 MHz/2.60 GHz output of the up-converter was coupled into the input of the LNA and to the down-converter. The output 720 MHz/1.2 GHz IF signal of the down-converter was connected to the receiver.

BER measurements were performed for the data rates depicted in Table 3 and Table 4. During all BER tests, the modulator was configured for the DVB-S2

modulation and coding schemes, including QPSK, 8PSK, 16 APSK and 32 APSK as well as various LDPC/BCH coding rates from 1/2 to 9/10 with a non-return to zero low (NRZ-L) data format on each channel. The test signal bandwidth was set to 375 MHz for X-band and 1.5 GHz for Ka-band. Baseband frames were set to a 64,800 bit-block. The pilot code was turned off. The modulator generated the Pseudo Random Bit Stream (PRBS) on each channel with baseband square root raised cosine (SRRC) filtering. In order to meet the NTIA spectral mask requirement, the SRRC roll-off factor was set to 0.25. There was no frequency dynamic for the test signal. The receiver was configured for the corresponding modulation and coding schemes for each BER measurement.

During the tests, a variable attenuator was used to vary the signal power in order to obtain  $E_b/N_0$  values for BERs from  $10^{-1}$  to  $10^{-7}$ . BER vs.  $E_b/N_0$  curves were plotted from the data points. The  $E_b/N_0$  was calculated from the measured  $E_s/N_0$ . A spectrum analyzer was placed in parallel with the receiver input. The spectrum analyzer plot was stored on disk for each data rate.

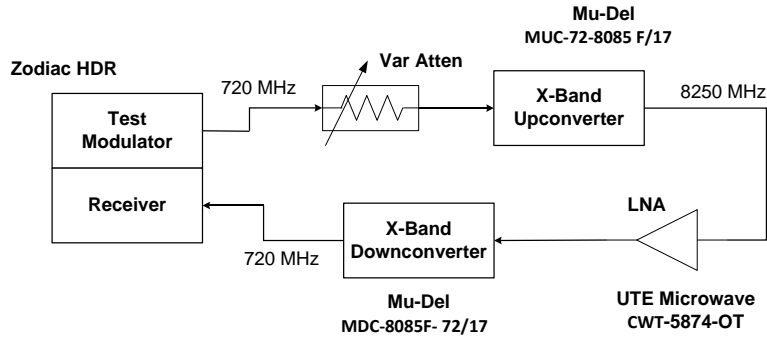

**Figure 3 Demonstration Medium Loop Test Configuration at X-band**

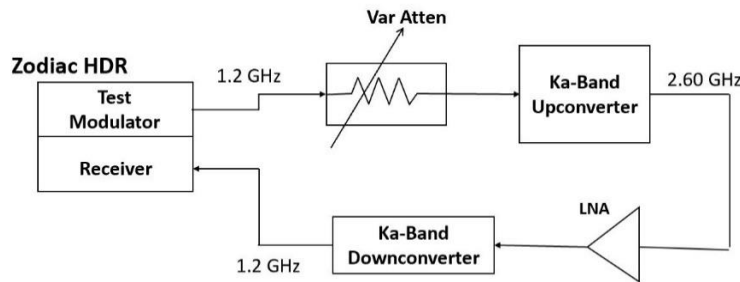

**Figure 4 Demonstration Medium Loop Test Configuration at Ka-Band**

### 6.1 DEMONSTRATION TEST RESULTS

The primary objective of the demonstration test was to determine the maximum data rates for DVB-S2 over the NEN X-band 375 MHz channel and Ka-band 1.5 GHz channel. The BER tests are the most critical measurement in considering DVB-S2 signal structures to achieve higher data rates for the NEN channel.

BER measurements of 24 cases will be performed for various modulation and coding schemes in the DVB-S2 standard, each in X-band and Ka-band. The maximum data rate determination is based on achieving an error free BER performance and meeting the NTIA 375 MHz/1.5 GHz spectral mask requirement for the data rate. The NEN will develop BER curves for select DVB-S2 modulation and coding schemes and data rates of interest, as well as summarize implementation loss performance for all test cases. Implementation loss was obtained by subtracting the theoretical additive white Gaussian noise (AWGN) curve from the actual measured curve. It reflects the loss due to channel distortion for the medium loop configuration. Results will be presented in the future.

### 7.0 LINK ANALYSIS STUDY FOR ACHIEVING DATA RATE THROUGH NEN X/KA-BAND CHANNEL-PA/ANTENNA SIZE VS ACHIEVABLE DATA RATE

The NEN performed a link analysis study to determine the requirements for spacecraft power amplifier level and antenna size to achieve the data rates in Table 3 and Table 4.<sup>8</sup> The study assumes the spacecraft is at a LEO 625 km altitude. Tables 5 and 6 show a summary of the study in X-band and Ka-band.

Table 5 assumptions:  $f = 8250$  MHz, S/C PA=2W, WG1 11.3 m G/T = 34.5 dB/K (clear sky), 3 loss, 3 dB margin. For PA = 5W, reduce the antenna size in the table by 4 dBi.

Table 6 assumptions:  $f = 26000$  MHz, S/C PA = 5 W, Alaska Station 11m, G/T= 40.6 dB/K (clear sky), 3 dB implementation loss, 3 dB link margin.

**Table 5 X-band DVB-S2 Achievable Data Rate vs. MODCODEs and S/C Antenna Size**

Mod/Coding Rate	1/4	1/3	2/5	1/2	3/5	2/3	3/4	4/5	5/6	8/9	9/10
<b>QPSK</b>	147	170	236.7	296.6	356.5	396.6	446.2	476.16	496.4	530	536.4
<b>Antenna Gain, dBi</b>	5.68	6.15	7.73	9.03	10.26	11.13	12.07	12.72	13.03	14.23	14.45
<b>8 PSK</b>					534	594	668.4	N/A	743.4	793.8	803.7
<b>Antenna Gain, dBi</b>					13.35	14.65	15.94	N/A	17.37	18.72	19.01
<b>16 APSK</b>						791	890	950	990	1057	1070
<b>Antenna Gain, dBi</b>						17.73	18.24	19.07	19.64	20.92	21.16
<b>32 APSK</b>							1111	1185.5	1235.7	1319	1336
<b>Antenna Gain, dBi</b>							20.78	21.74	22.31	23.72	24.08

**Table 6 Ka-band DVB-S2 Achievable Data Rate vs. MODCODEs and S/C Antenna Size**

Mod/Coding Rate	1/4	1/3	2/5	1/2	3/5	2/3	3/4	4/5	5/6	8/9	9/10
<b>QPSK</b>	245	328	394.7	494.4	594.5	661	743.7	793.5	827.3	883.2	894.3
<b>Antenna Gain, dBi</b>	11.92	13.03	13.97	15.27	16.50	17.37	18.30	18.96	19.45	20.47	20.69
<b>8 PSK</b>					890	990	1114	N/A	1239	1323	1340
<b>Antenna Gain, dBi</b>					19.79	20.93	22.18	N/A	23.62	24.96	25.25
<b>16 APSK</b>						1318.5	1483	1582.8	1650	1761.5	1783.5
<b>Antenna Gain, dBi</b>						23.24	24.48	25.31	25.87	27.16	27.40
<b>32 APSK</b>							1850	1975.8	2059.5	2199	2226
<b>Antenna Gain, dBi</b>							27.01	27.98	29.55	29.96	30.31



Figure 5 and Figure 6 show the spacecraft antenna size vs achievable data rate for the modulation and code rate combinations (MODCODEs) within the DVB-S2 standard from QPSK to 32 APSK and code rates from

1/4 to 9/10 for X-band and Ka-band respectively. It provides a trades-off between PA, antenna size, MODCODEs and achievable data rate.

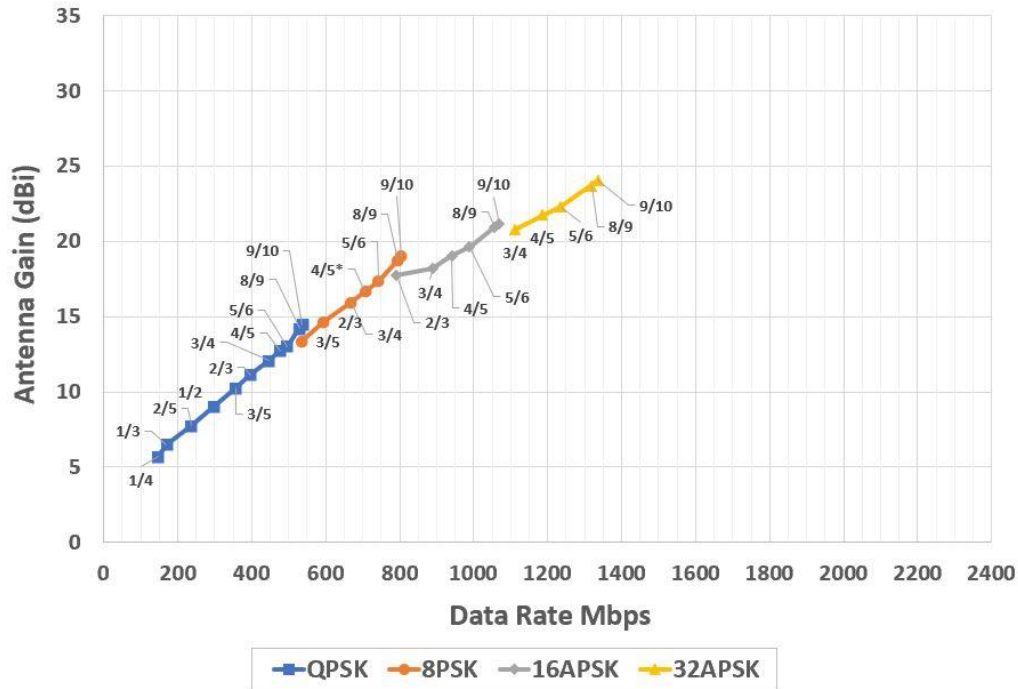

Figure 5 X-band Achievable Data Rates vs. Spacecraft Antenna Gain and MODCODES

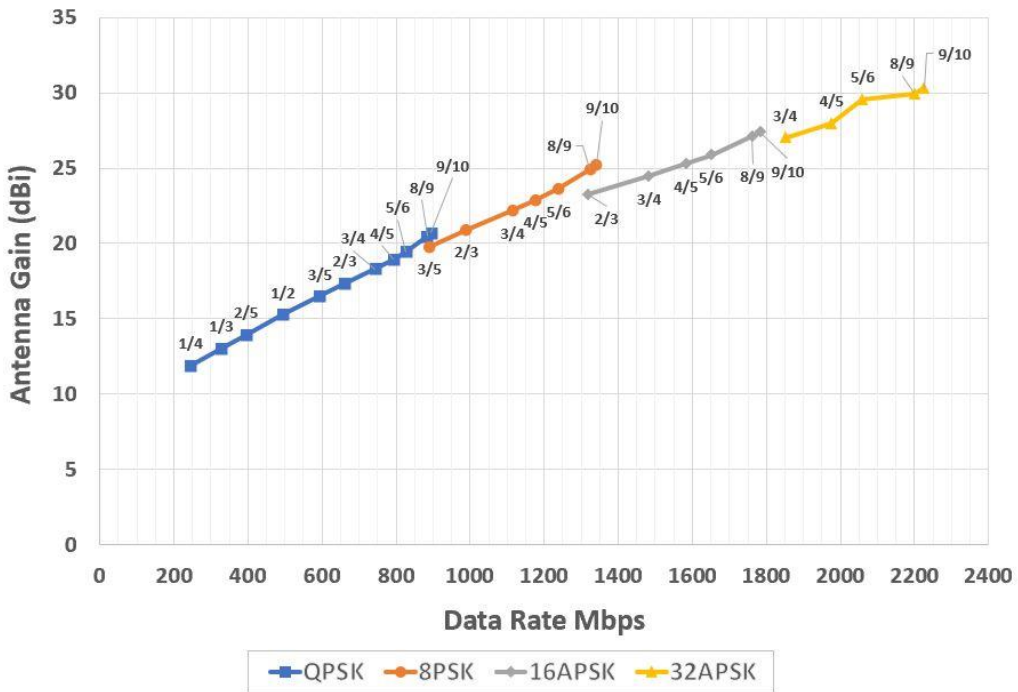

Figure 6 Ka-band Achievable Data Rates vs. Spacecraft Antenna Gain and MODCODES

## 8.0 COTS CUBESAT/SMALL SATELLITE X/KA-BAND COMMUNICATION SYSTEMS

Multiple vendors offer commercial off-the-shelf (COTS) communications systems. The following five DVB-S2 communications systems are described:

- Astro-Digital DVB-S2 Ka-band Transmitter
- EnduroSat X-Band DVB-S2 Transmitter
- Syrlinks EWC27 X-band Transmitter
- GomSpace NanoCom XT8250 X-band Transmitter
- SAIT high-speed X-band Transmitter

### 8.1. Astro Digital Ka-band DVB-S2 Transmitter

Astro Digital launched its third generation DVB-S2 Ka-band transmitter on a CubeSat in 2018 and achieved 185 Mbps with a Kongsberg Satellite Services (KSAT) ground station in Svalbard, Norway. In a typical 10-minute pass, greater than 13 Gigabytes (GB) was downloaded from the spacecraft. See Figure 7 for a picture of the integrated spacecraft radio and antenna. Future generations are planned to achieve greater than 2 Gbps. Ka-band takes advantage of the large pipe bandwidth of 1.5 GHz to achieve high data rates, compared against 375 MHz for X-band Earth science, and 5 MHz for S-band.

Smallsats are more SWAP constrained than traditional spacecraft. Ka-band, because of its smaller wavelength, enables smaller spacecraft transmitter and antenna components when compared with X-band and S-band. The Ka-band transmitter and antenna shown in Figure 7 fits into a 10x10x10 cm. or 1U CubeSat volume. The ground station used to demonstrate communications

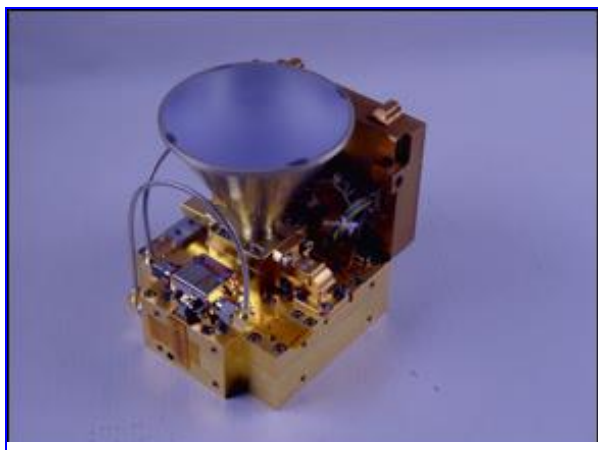

**Figure 7 Astro Digital DVB-S2 Communications System**

over Ka-band was also relatively small at 2.8-meter. The smaller the ground station, the lower the cost.

### 8.2 EnduroSat X-Band DVB-S2 Transmitter

EnduroSat's X-Band Transmitter, shown in Figure 8, is a high data-rate satellite module operating in the 8025-8400 MHz frequency band. The transmitter is in compliance with DVB-S2 ETSI EN 302 307 and CCSDS DVB-S2 standard. The small overall dimensions of the X-band transmitter makes it a perfect choice for CubeSat or nanosat LEO missions. Maximum transmit power is 2 Watts. It supports QPSK, 8 PSK, and 16 APSK with a maximum symbol rate of 30 Msps. The transmit data rate in LEO is up to 120 Mbps.



**Figure 8 EnduroSat X-band Transmitter Module**

### 8.3 Syrlinks X-band Transmitter

Syrlinks EWC27 high data rate transmitter operates in the 8025-8450 MHz frequency range. It supports 100 Mbps with convolutional coding (7, 1/2) and OQPSK. The transmitter was validated on board the GOMX-2 satellite. Syrlinks is working with CNES to upgrade the X-band transmitter to use the DVB-S2 CCSDS standard for data rate higher than 100 Mbps. With Variable Coding and Modulation (VCM) mode, it will provide 60% increase of downlink data compared to fixed rate modulation<sup>1</sup>.

Syrlinks is considering evolving the X-band transmitter to move forward toward the Ka-band DVB-S2 high data rate transmitter. The target data rate is in the order of 200-300 Mbps, which is believed to be a suitable range for CubeSat and nanosatellite missions.

### 8.4 GOMSPACE X-band DVB-S2 Transmitter

The GomSpace NanoCom XT8250 X-band transmitter is comprised of an integrated antenna and an SDR-based modulator operating in 8000-8500 MHz frequency range. It is DVB-S2 compatible. The configurable RF output power is 3 W. The system supports downlink rate

up to 225 Mbps. The NanoCom XT8250 is for innovative nanosatellite remote sensing missions requiring high downlink data rates.

### 8.5 SAIT X-band DVB-S2 Transmitter

According to SAIT literature, the SAIT high-speed X-band downlink transmitter operates in 8100-8500 MHz frequency range. The maximum transmit power is 8 W. It supports QPSK, 8 PSK, and 16 APSK with a symbol rate of 200 Msps. In DVB-S2 mode, it supports 880 Mbps.

The high rate transmitter worked successfully with the International Space Station and the Aist Russian technology demonstration satellite.

### 9.0 LOW COST DVB-S2 X TRANSMITTER DEVELOPMENT CONCEPT

GSFC's NEN is collaborating with University of Alaska Fairbanks (UAF) to develop a DVB-S2 S-band SDR

transmitter for the CubeSat Communications Platform (CCP) mission. Currently, a DVB-S2 software modulator has been developed, tested and validated at GSFC's Communication Standard and Testing Lab (CSTL). The software modulator was verified with the Cortex HDR DVB-S2 mode and demonstrated that it is coded correctly with respect to the CCSDS DVB-S2 standard.

A low-cost DVB-S2 X-band transmitter concept leverages the UAF effort. Figure 9 illustrates the conceptual design of this DVB-S2 X-band transmitter.

H9

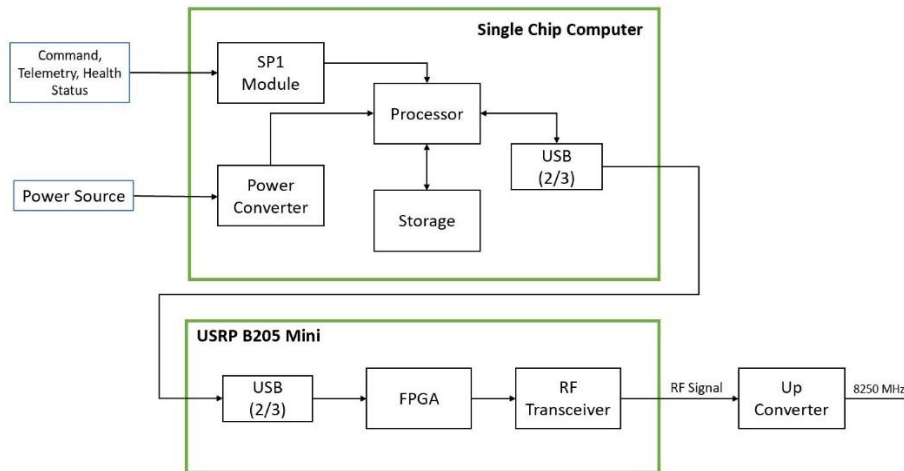

Figure 9 Low Cost DVB-S2 X-Band SDR Transmitter Design Block Diagram

As shown in **Error! Reference source not found.**, the design contains a COTS single board computer and the Ettus USRP B205 min SDR. The quadrature signal I/Q generated by the processor in the single board are sent to the Ettus B205mini SDR using a Universal Serial Bus (USB) 2/3 link. Optimization of data rate traded-off will be evaluated between the Ettus B205mini onboard Field Programmable Gate Array (FPGA) and the processor in the single board computer.

The B205 mini SDR, shown in Figure 10, is a \$1500 radio in the frequency range of 70 MHz to 6 GHz with a 56 MHz bandwidth. Assuming two samples per second,

the radio symbol rate will be 30.7 M Symbols/sec. The support data-rate depends on modulation and coding schemes. With DVB-S2 16 APSK 9/10, 109.6 Mbps is achievable.<sup>9</sup> NASA's Ames Research Center (ARC) has flown an Ettus B205 mini for the TechEdSat mission for S-band 5 Mbps link with NEN support. The Ettus B205 radio can be upgraded to use DVB-S2 with software and firmware implementation in the radio and flight computer system.



**Figure 10 Ettus B205 Mini SDR**

The CCP DVB-S2 software modulator will be translating into FPGA VHDL for high data rate for a DVB-S2 X-band transmitter.

The implementation of high data rate, say, 109.6 Mbps, will depend on the selected single chip computer processor power and the FPGA of the Ettus B205 mini. It will be evaluated prior to any optimization along with the required processing power, bandwidth, and the Ettus radio FPGA. The Ettus radio frontend also includes a configurable output band-pass filter which can be used in place of any filtering done by the DVB-S2 software modulator.

The RF output signal will be up-converted into NEN X-band frequency range.

Analysis was performed that the NEN Wallops Island, Virginia 11-meter X-band ground station is able to support the DVB-S2 16 APSK 9/10 109.6 Mbps link at 3 dB margin with a 2 W PA and 11 dBi antenna gain<sup>8</sup>. A 2 W PA is used often in CubeSats. The Antenna Development Corporation has a micro-strip array antenna with a gain of more than 11 dBi.

### 9.1 Future NEN Compatible DVB-S2 X/Ka-band High Data Rate (HDR) Transmitter Evolution.

The NEN is looking for collaborations with industry/universities to develop the future NEN compatible HDR DVB-S2 X-band and Ka-band transmitter. Currently, the NEN is working with University of Alaska Fairbanks (UAF) for a low cost DVB-S2 S-band transmitter supporting 15 Mbps over the NEN S-band 5 MHz channel. This effort can be extended to X-band for over 100 Mbps by upgrading the FPGA and up converting the S-band frequency to X-band. The NEN and ARC are investigating the possibility of collaborating with a vendor to upgrade their SmallSat/CubeSat X-band SDR transceiver to incorporate DVB-S2 for a data rate up to 1 Gbps including the VCM feature via a Small Business

Innovative Research (SBIR) contract. The NEN CubeSat WFF Test Bed supports the development and testing of these spacecraft radios.

## 10.0 CONCLUSION

NASA's NEN has successfully demonstrated DVB-S2 MODCODEs for high data rate at X-band 375 MHz channel and Ka-band 1.5 GHz channel with today's station receiver. It achieves 1.3 Gbps at X-band and 2.2 Gbps at Ka-band with 32 APSK 9/10. The station Cortex receiver future capability will be upgraded to 1.2 G Symbols per second from today's 500 M Symbol per second. This will enable the achievable data rate to above 5 Gbps at Ka-band. An analysis was performed to provide trades-off among MODCODES, data rate, spacecraft antenna size and PA power. A low cost SmallSat/CubeSat X-band DVB-S2 transmitter at a data rate over 100 Mbps design concept and implementation with commercial off-the-shelf (COTS) system were presented. COTS CubeSat/SmallSat X-band and Ka-band communication systems were identified. Results of the demonstration are valuable to the user community for the planning missions with higher data rates. DVB-S2 will increase science data return for all missions and enable support for a greater numbers of CubeSats/SmallSats at high data rates.

### Acknowledgments

The authors wish to thank NASA's Near Earth Network for funding investigations for improved space communications support for the Small Satellite/CubeSat community.

### References

1. Fernandez, M., Dehaene, T., Michaud, G., Bataille, P., Dudal, C., Lafabrie, P., Gaboriaud, A., Issler, J., Rousseau, F., and Ressouche, A., "X-band Transmission Evolution towards DVB-S2 for Small Satellites", Small Satellite Conference, Logan, Utah, August 16, 2016, <https://digitalcommons.usu.edu/cgi/viewcontent.cgi?article=3386&context=smallsat>
2. Morello, A. and Mignone, V., "DVB-S2: The Second Generation Standard for Satellite Broad-band Services", Proceedings of the IEEE, vol. 94, No. 1, January 2006.
3. "Near Earth Network (NEN) CubeSat Communications." NASA Technical Reports \Server, January 1, 2017, <https://ntrs.nasa.gov/search.jsp?R=20170000974>
4. Yen Wong, Scott Schaire, Steven Bundick, Obadiah Kegege, Serhat Altunc, Peter Fetterer, "NASA Near Earth Network (NEN) DVB-S2 Demonstration Testing for Enhancing Data Rates

for CubeSat/SmallSat Missions”, Small Satellite Conference, Logan, UT, August 2019.

5. GSFC internal report, NEN DVB-S2 X/Ka-band demonstration testing test plan, March 2020
6. ETSI. (2014, July). Digital Video Broadcasting (DVB); Second generation framing structure, channel coding and modulation systems for Broadcasting, Interactive Services, News Gathering and other broadband satellite applications; Part 1: DVB-S2. Retrieved December 2019, from [https://www.etsi.org/deliver/etsi\\_en/302300\\_302399/30230701/01.04.01\\_20/en\\_30230701v010401a.pdf](https://www.etsi.org/deliver/etsi_en/302300_302399/30230701/01.04.01_20/en_30230701v010401a.pdf)
7. CCSDS 131.3-B-1. (2013, March). CCSDS Space Link Protocols over ETSI DVB-S2 Standard. Retrieved November 2019, from <https://public.ccsds.org/Pubs/131x3b1.pdf>
8. GSFC internal report, NEN DVB-S2 106.9 Mbps with 16 APSK, 9/10, April 2020.
9. GSFC internal report, DVB-S2 NEN X/Ka-band down link MODCODEs vs PA/antenna size analysis, April 2020.