

NASA/TM-2020-5005687

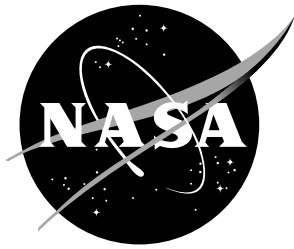

Safeguard with Autonomous Navigation Demonstration Technical Closeout Report

*Steven Geuther, Louis Glaab, Thomas Johnson, Rafia Haq, and David Hare
Langley Research Center, Hampton, Virginia*

September 2020

NASA STI Program... in Profile

Since its founding, NASA has been dedicated to the advancement of aeronautics and space science. The NASA scientific and technical information (STI) program plays a key part in helping NASA maintain this important role.

The NASA STI Program operates under the auspices of the Agency Chief Information Officer. It collects, organizes, provides for archiving, and disseminates NASA's STI. The NASA STI Program provides access to the NASA Aeronautics and Space Database and its public interface, the NASA Technical Report Server, thus providing one of the largest collections of aeronautical and space science STI in the world. Results are published in both non-NASA channels and by NASA in the NASA STI Report Series, which includes the following report types:

- **TECHNICAL PUBLICATION.** Reports of completed research or a major significant phase of research that present the results of NASA programs and include extensive data or theoretical analysis. Includes compilations of significant scientific and technical data and information deemed to be of continuing reference value. NASA counterpart of peer-reviewed formal professional papers, but having less stringent limitations on manuscript length and extent of graphic presentations.
- **TECHNICAL MEMORANDUM.** Scientific and technical findings that are preliminary or of specialized interest, e.g., quick release reports, working papers, and bibliographies that contain minimal annotation. Does not contain extensive analysis.
- **CONTRACTOR REPORT.** Scientific and technical findings by NASA-sponsored contractors and grantees.

- **CONFERENCE PUBLICATION.** Collected papers from scientific and technical conferences, symposia, seminars, or other meetings sponsored or co-sponsored by NASA.
- **SPECIAL PUBLICATION.** Scientific, technical, or historical information from NASA programs, projects, and missions, often concerned with subjects having substantial public interest.
- **TECHNICAL TRANSLATION.** English-language translations of foreign scientific and technical material pertinent to NASA's mission.

Specialized services also include organizing and publishing research results, distributing specialized research announcements and feeds, providing information desk and personal search support, and enabling data exchange services.

For more information about the NASA STI Program, see the following:

- Access the NASA STI program home page at <http://www.sti.nasa.gov>
- E-mail your question to help@sti.nasa.gov
- Phone the NASA STI Information Desk at 757-864-9658
- Write to:
NASA STI Information Desk
Mail Stop 148
NASA Langley Research Center
Hampton, VA 23681-2199

NASA/TM-2020-5005687

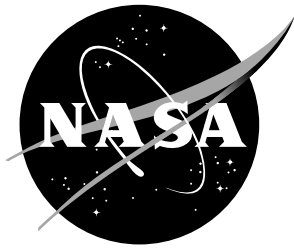

Safeguard with Autonomous Navigation Demonstration Technical Closeout Report

*Steven Geuther, Louis Glaab, Thomas Johnson, Rafia Haq, and David Hare
Langley Research Center, Hampton, Virginia*

National Aeronautics and
Space Administration

Langley Research Center
Hampton, Virginia 23681-2199

September 2020

Acknowledgments

This work was funded by NASA Langley Research Center's (LaRC) Office of Strategic Analysis, Communications and Business (OSACB), Engineering Directorate, Research Services Directorate, and the Accelerate Collaboration & Technologies to Architect a Cultural Transformation (ACT-2) project. The authors thank the Unmanned Aircraft Systems Operations Office (UASOO) and the Aviation Safety Review Board (ASRB) at NASA LaRC for the support and guidance in the flight test campaign. The authors thank John Foster at NASA Langley for recommendations in the predictive analysis of understanding wind effects. Finally, the authors thank NASA LaRC senior leadership for supporting an innovative method of technology transfer through the SAND competition.

<p>The use of trademarks or names of manufacturers in this report is for accurate reporting and does not constitute an official endorsement, either expressed or implied, of such products or manufacturers by the National Aeronautics and Space Administration.</p>

Available from:

NASA STI Program / Mail Stop 148
NASA Langley Research Center
Hampton, VA 23681-2199
Fax: 757-864-6500

Abstract

In preparations for the Safeguard with Autonomous Navigation Demonstration (SAND) competition, technical activities for validation of utilizing Safeguard as a independent flight termination system and a scoring system took place. The activities included assessment of the size of the flight area to allow adequate flight operations while maintaining margins for containment, development of an interface companion box to induce terminations, testing of Safeguard with intentional terminations of vehicles approaching a stay-in boundary, data analysis to understand the trajectory of multirotor in a freefall post-termination with wind and propeller spin down effects, and development of a scoring system using GPS data collected by Safeguard. Throughout this precursor of the SAND competition, a simple but reliable and easily verifiable companion system was developed to use the Safeguard signal to initiate a flight termination. In addition, multiple flight tests using multirotor unmanned aircraft system (UAS) with Safeguard equipped as both a payload and an active independent flight termination were carried out. Two vehicles underwent a flight termination in order to collect data to minimize and mitigate the uncertainty of the fall trajectory, which lead to the development of a predictive trajectory estimate for the competition use. Finally, a robust scoring system was developed to be used in the SAND competition from the outputs of the logged data files on Safeguard.

Contents

1	Introduction	5
2	Flight Test Campaign	6
2.1	Darling Stadium	7
2.2	Langley Speedway	9
2.3	Vehicle and Competition Checkouts	11
2.4	Reliable Flight Termination Interface Unit	14
2.5	Tarot X6 Vehicle Termination	17
2.6	DJI S1000 Vehicle Termination	18
3	Results of Vehicle Terminations	18
3.1	Post-processed Data - Tarot X6	18
3.1.1	Pixhawk Data Collection	19
3.1.2	Safeguard Data Collection	22
3.2	Post-processed Data - DJI S1000	24
3.2.1	Pixhawk Data Collection	24
3.2.2	Safeguard Data Collection	27
4	Aerodynamic Prediction Analysis	29
4.1	Ballistic Trajectory Approach	29
4.2	AirSTAR Drift Prediction Tool Approach	32
5	Safeguard Configuration for SAND	34
6	Scoring System	35
6.1	Qualitative Score	35
6.2	Quantitative Score	36
6.3	Pre-flight Scoring System Requirements	38
6.4	Scoring System Quantitative Data Collection	39
6.4.1	Limitations	43
7	Conclusions	43
8	Recommendations	44

List of Figures

1	SAND stay-in boundary and sample flight plan within operational zone.	8
2	Darling Stadium comparison to the stay-in boundary on the CERTAIN range.	9
3	SAND larger stay-in boundary and sample flight plan within operational zone.	10
4	Langley Speedway comparison to the stay-in boundary at NASA Langley.	11
5	Safeguard system with GPS antenna on lower payload tray.	12
6	Safeguard system with GPS antenna on upper deck.	12
7	Sample Safeguard visual data for 5 m/s and 30 meter combination within operational zone.	13
8	Block diagram of integrated Safeguard system.	15
9	Kirintec electronic wire cutter.	15
10	Schematic of the reliable flight termination interface unit.	16
11	Reliable flight termination interface unit.	17
12	Pixhawk Tarot X6 trajectory in latitude and longitude.	19
13	Pixhawk Tarot X6 x-displacement versus time in a free fall.	20
14	Pixhawk Tarot X6 y-displacement versus time in a free fall.	20
15	Pixhawk Tarot X6 y-displacement versus x-displacement in a free fall.	21
16	Pixhawk Tarot X6 x-velocity (ground speed) versus time in a free fall.	21
17	Pixhawk Tarot X6 y-velocity versus time in a free fall.	21
18	Safeguard Tarot X6 x-displacement versus time in a free fall.	22
19	Safeguard Tarot X6 y-displacement versus time in a free fall.	22
20	Safeguard Tarot X6 y-displacement versus x-displacement in a free fall.	23
21	Safeguard Tarot X6 x-velocity (ground speed) versus time in a free fall.	23
22	Safeguard Tarot X6 y-velocity versus time in a free fall.	23
23	Pixhawk DJI S1000 trajectory in latitude and longitude.	25
24	Pixhawk DJI S1000 x-displacement versus time in a free fall.	25
25	Pixhawk DJI S1000 y-displacement versus time in a free fall.	26
26	Pixhawk DJI S1000 y-displacement versus x-displacement in a free fall.	26
27	Pixhawk DJI S1000 x-velocity (ground speed) versus time in a free fall.	26
28	Pixhawk DJI S1000 y-velocity versus time in a free fall.	27
29	Safeguard DJI S1000 x-displacement versus time in a free fall.	27
30	Safeguard DJI S1000 y-displacement versus time in a free fall.	28
31	Safeguard DJI S1000 y-displacement versus x-displacement in a free fall.	28
32	Safeguard DJI S1000 x-velocity (ground speed) versus time in a free fall.	28
33	Safeguard DJI S1000 y-velocity versus time in a free fall.	29
34	Tarot X6 termination trajectory.	30
35	DJI S1000 termination trajectory.	31
36	Prediction tool match of the Tarot X6 data.	33
37	Prediction tool match of the DJI S1000 data.	33

38	Monte Carlo analysis for the Tarot X6 with variation of coefficient of drag and wind.	33
39	Sample scoring grid for the SAND competition.	40
40	Sample scoring grid flight for the SAND competition without target of interest.	40
41	Safeguard target of interest 3D test side view.	41
42	Safeguard target of interest 3D test ground view.	42
43	Sample scoring grid flight for the SAND competition with target of interest.	42
44	Target of interest LED display.	43

Nomenclature

AGL Above Ground Level

AR Augmented Reality

CERTAIN City Environment Range Testing for Autonomous Integrated Navigation

FOV Field of View

FTOSR Flight Test and Operations Safety Report

IFTS Independent Flight Termination System

LaRC Langley Research Center

NAS National Air Space

RFTIU Reliable Flight Termination Interface Unit

SAND Safeguard with Autonomous Navigation Demonstration

UAS Unmanned Aircraft System

UAV Unmanned Aerial Vehicle

UV Ultraviolet

VR Virtual Reality

1 Introduction

The Safeguard with Autonomous Navigation Demonstration (SAND) Challenge was proposed as an opportunity for small businesses to compete in an autonomous unmanned aerial vehicle (UAV) competition. Safeguard was designed to address some of the safety critical risks associated with flying UAVs in the national airspace system (NAS) including: 1) flight outside of approved airspace; 2) unsafe proximity to people or property; and 3) critical system failure [1]. The challenge was to operate under the Federal Aviation Administration (FAA) Part 107 Small Unmanned Aircraft Regulations. The objectives of the SAND competition were to expedite technology transfer to industry and to gather valuable user feedback regarding potential future improvements to Safeguard.

NASA Langley Research Center's (LaRC) patented Safeguard technology would fly on-board the competitor's vehicle while navigating a course. Safeguard is NASA's manned-aviation quality geofencing technology [2]. The Safeguard software is a verified and validated independent system designed to supersede UAV guidance, navigation and control systems, and when necessary, physically prevent the vehicle from accessing restricted air space, when configured in conjunction with the autopilot. This assures the UAV complies with regulatory property protection and safety requirements for people and property on the ground, for certain areas of operation. The SAND challenge was planned to demonstrate the successful surveillance of a simulated post-natural disaster scenario with assured vehicle range containment.

The primary objectives of the SAND Challenge were:

1. To demonstrate assured autonomous vehicle range containment of UAVs without direct human intervention using NASA's Safeguard technology to stakeholders, the emerging UAV industry, and the public.
2. To collect feedback from competitors and stakeholders to enable potential improvements and usages of Safeguard and enable further analysis that could inform new regulatory policies that support expanded use of commercial UAV systems.
3. To inform regulatory stakeholders including federal, state, and local governments on the potential operational benefits of integrating NASA's Safeguard technology to UAVs to aid first responders in natural disasters events.
4. To engage the emerging UAV operator market to the value proposition of NASA's Safeguard technology and its potential use cases for commercialization and licensing.

The Safeguard technology can be configured to be flown as fully integrated independent flight termination systems (IFTS) mounted on the UAV. A companion termination system, developed for the SAND test flights, was integrated with Safeguard to sever motor power when Safeguard signaled the vehicle was leaving the defined stay-in area. This companion termination system was designated as the Reliable Flight Termination Interface Unit (RFTIU). This system provided a direct pathway to remove power to the vehicle and was easy to inspect and verify. The system also enabled low-risk integration into the vehicle for checkout purposes. The Safeguard system can provide a signal through a relay in order to provide the RFTIU the ability to engage and sever power to the vehicle if that vehicle was in danger of leaving the defined stay-in boundary. Safeguard provides additional warning signals and a serial message that can be used by an UAV autopilot to provide additional

situational awareness with regards to the defined operational area. The additional signals provide indications of warning conditions and the serial message includes the heading and range to the closest boundary points. For the competition, Safeguard would also be used to support competition scoring through the GPS data that is recorded in the Safeguard system.

2 Flight Test Campaign

For the SAND competition, the main objective for Safeguard was to provide vehicle containment for the defined operational area. The use of Safeguard as a scoring system was a secondary objective. In order to test a complete IFTS for range containment, The RFTIU was integrated with Safeguard to sever motor power when a flight was to be terminated. The integrated IFTS system was validated through flight testing, providing the data needed to evaluate Safeguard in a small operational area and understand the predictive calculations and configuration parameters used to provide adequate margins for the proposed competition area. This unique data would also assist in accounting for the uncertainty in post-termination trajectory based upon varying winds, aerodynamics and propeller spin down effects that typically aren't accounted for in trajectory calculations. In addition, the data set will help develop other flight termination systems outside of SAND. Two vehicle types were used in the testing phases of the SAND project: a Tarot X6 and a DJI S1000. The SAND project proposed to phase the operations of testing the system as a walk before run approach. In addition, in order to assess the Safeguard system, the RFTIU was designed and built to indicate that Safeguard would have sent a terminate command and, if armed, fire a termination device. The RFTIU would be tested in the lab and in flight prior to performing a termination. Finally, two vehicles, one Tarot X6 and one DJI S1000, had intentional terminations showing a start to finish of using the Safeguard system as an IFTS to ensure range containment. Including the two flight terminations, the Safeguard system went through 48 different flights with a total flight time of 4 hours in preparations for the SAND competition.

The flight operations were broken into three risk reduction phases. The first phase included doing vehicle checkouts and assuring that the competition was feasible in the area proposed for the SAND competition. The second phase collected data with Safeguard being incorporated as a flight termination device for flight tests in both nominal search patterns and off-nominal patterns with intentional deviations to breach the stay-in boundary. This phase was further broken down into multiple parts as a walk before run approach before arming and terminating a vehicle. The vehicle first utilized a light on the RFTIU to showcase when the termination signal was sent and was recorded by on-board video. Then the system was tested with a wire cutter on a wire not connected to any vehicle components. Lastly, the entire system was configured to incorporate the wire cutter on the vehicle motor power wire. Vehicle speeds and altitudes were selected to eliminate warning and termination commands from Safeguard while searching the simulated competition area. The RFTIU enabled thorough testing of the integrated system without risking the vehicle. Progressive testing increased complexity and realism of the end-to-end system.

In the event the vehicle was in danger of breaching the desired stay-in boundary, Safeguard would send a termination signal to keep the vehicle from going beyond the defined boundary. The phased approach to testing provided demonstrations that the UAV could be operated within the defined flight area of 50 by 50 meter without signaling a termination and would only terminate the flight at the expected locations as the flight was directed toward the stay-in boundary. The termination flights provided valuable data in determining configuration settings to ensure vehicle containment while providing adequate margins for the 50 by 50 meter flight area and for winds up to 15 knots. Finally, the third phase was to assess the feasibility and provide data for testing the scoring system for the competition.

2.1 Darling Stadium

The proposed competition area was located at Darling Stadium in Hampton, VA. Therefore, a surrogate competition area was developed on the City Environment Range Testing for Autonomous Integrated Navigation (CERTAIN) range at NASA Langley for testing. The 50 by 50 meter flight area is centered in the larger geofence/stay-in boundary for range containment (red boundary shown in Figure 1). The closest boundary of the operational zone to the stay-in boundary was approximately 27 meters. This stay-in boundary represented the track at Darling Stadium and one side of unused bleachers on the far side of the track. A comparison of the stay-in boundary used on the CERTAIN range and Darling Stadium can be seen in Figure 2.

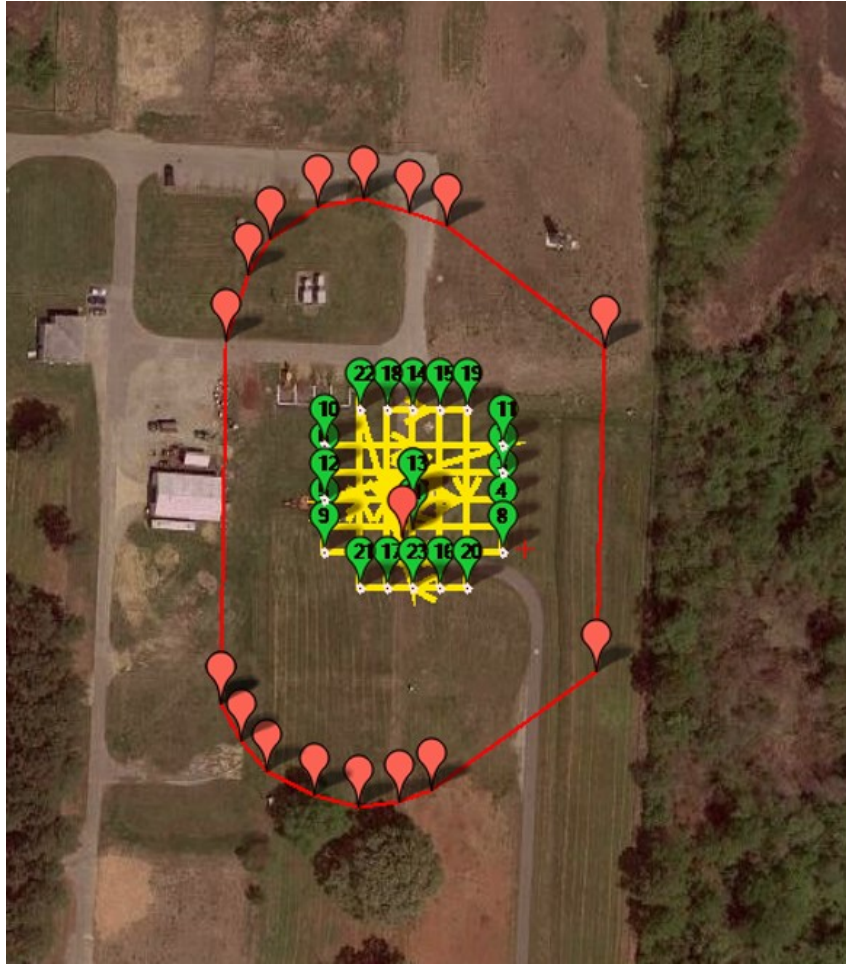

Figure 1. SAND stay-in boundary and sample flight plan within operational zone.

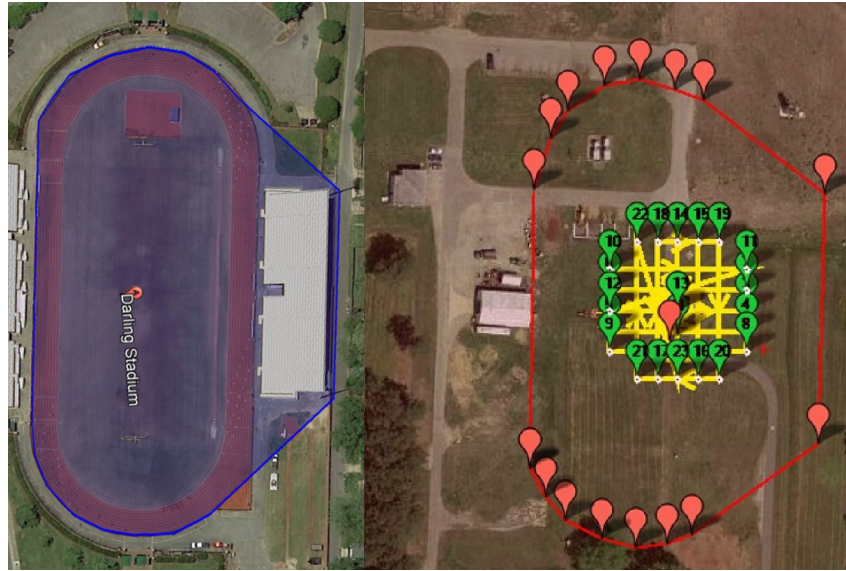

Figure 2. Darling Stadium comparison to the stay-in boundary on the CERTAIN range.

2.2 Langley Speedway

It should be noted that at a later date, the stay-in boundary was increased as the competition location changed to the Langley Speedway in Hampton, VA. However, there was no flight testing associated with the larger stay-in boundary. A surrogate boundary of the Langley Speedway on the CERTAIN range can be seen in Figure 3. For this proposed boundary, the flight area is centered in the middle of the building in the center of the race track. The closest boundary of the flight zone to the stay-in boundary was approximately 40 meters. Similarly to Darling Stadium, a comparison of the Langley Speedway race track to the proposed stay-in boundary and flight area on the CERTAIN range can be seen in Figure 4.

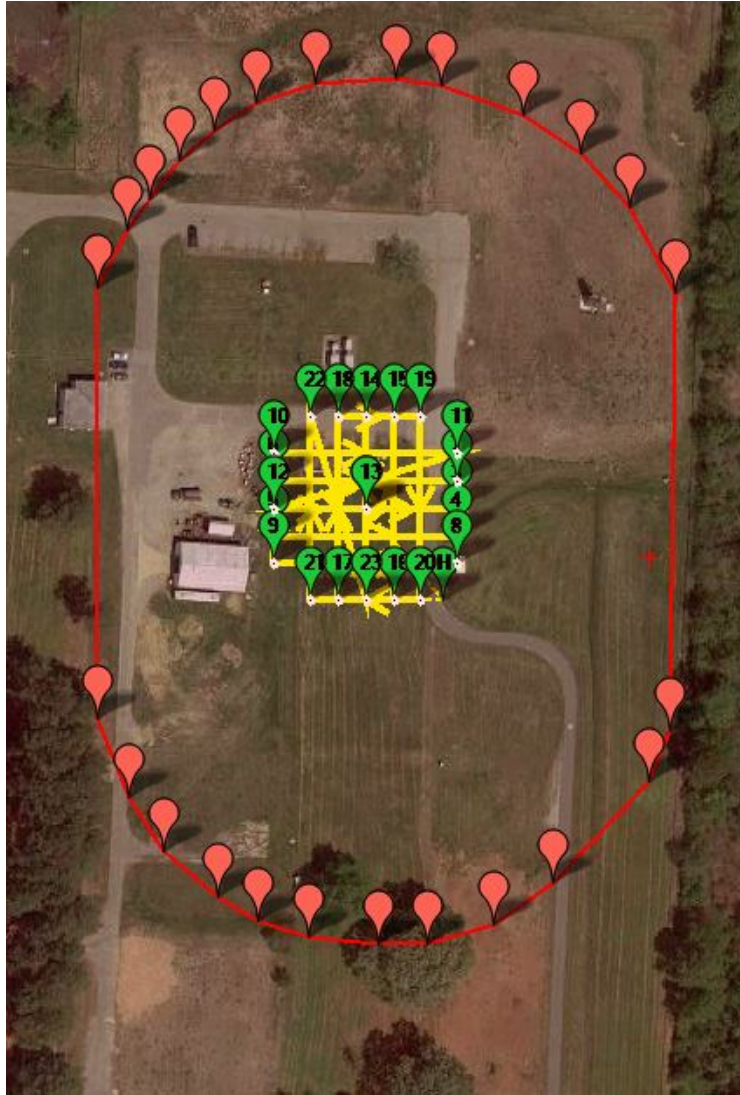

Figure 3. SAND larger stay-in boundary and sample flight plan within operational zone.

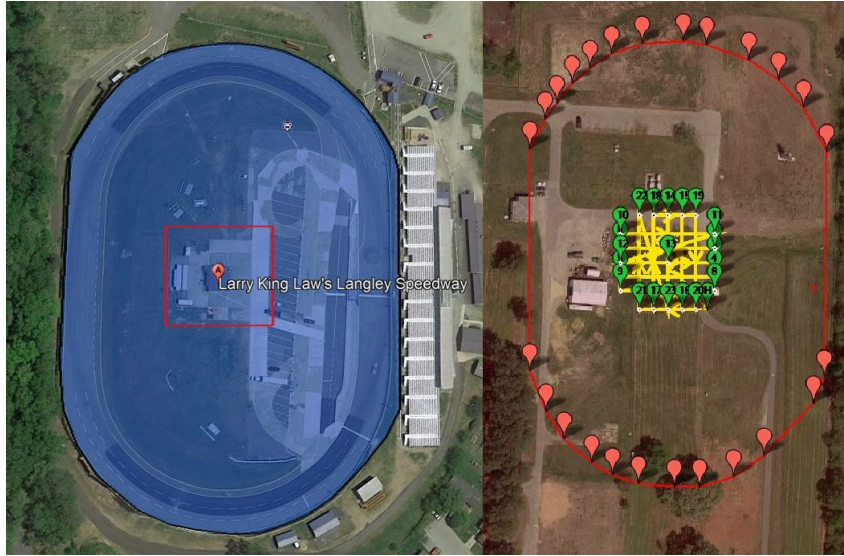

Figure 4. Langley Speedway comparison to the stay-in boundary at NASA Langley.

2.3 Vehicle and Competition Checkouts

Within the flight test campaign, the main goal was to observe if the proposed boundary area provided adequate margin for the vehicle to operate in the 50 by 50 meter flight area without Safeguard signaling a termination. These practice flight tests would assure that there would be no anomalies or extraordinary errors that would trigger a false positive in termination. These flights were performed at different altitudes and speed combinations to assess the performance of the GPS and Safeguard system within the overall competition area and vehicle setup. The test flights were conducted at all combinations with vehicle speeds of 2 and 5 m/s and altitudes of 15 and 30 meters. Throughout the testing the GPS and Safeguard performance was considered adequate. The reinforcing takeaway of best practices during the early exploratory flights in the first phase was that the Safeguard GPS antennas should have a clear and open view of the sky. Initially, the GPS antennas were mounted on the vehicle on a lower payload tray, seen in Figure 5. A comparison of mounting the GPS antennas to the upper deck of the vehicle, seen in Figure 6, showed a reduction in GPS position and altitude error by approximately 500% and 200%, respectively. In addition, for the competition, it was assessed that the maximum vehicle speed and altitude should be 5 m/s and 30 meters. This maximum combination allowed for minimal warnings (yellow lines) and zero terminations (red lines) for the flight path throughout the test flights, which can be seen in Figure 7. Finally, a procedural step while arming the Safeguard unit was discovered, otherwise partial data would not be collected. During the start-up of Safeguard it was noticed that the Safeguard program must be disconnected in the software before attempting to disconnect the ethernet cable to the vehicle.



Figure 5. Safeguard system with GPS antenna on lower payload tray.



Figure 6. Safeguard system with GPS antenna on upper deck.



Figure 7. Sample Safeguard visual data for 5 m/s and 30 meter combination within operational zone.

In addition to the vehicle parameters that were required for testing, Safeguard software parameters could also be tuned to provide more or less margin within the trajectory calculation for warning and termination points [3] [4] [5]. Adjustment and iteration of the Safeguard parameters can be used to manage risk to the vehicle and range containment. Safeguard internal electronics have a closed relay by default, when the relay opens a signal is sent to terminate. The relay opens under the following conditions. Safeguard uses GPS data from two different sources. If either of the sources fail, a termination signal would be sent. If there is excessive divergence between the two GPS sources, there is also a termination signal sent. If the vehicle exceeds the altitude limits that are defined, a termination would occur. Finally, the proximity to the stay-in boundary, regardless of direction, as a function of speed and altitude can create a termination signal. Within this calculations, the termination point is computed through four parameters. The first is a ballistic trajectory (an option of using drag, if known, is available too) that uses the altitude, speed of the vehicle (both horizontal and vertical), and a manual input of acceleration (both horizontal and vertical) for a worst case scenario over a specified time step. The acceleration terms provide an additional boost in initial velocity based upon the acceleration and a 0.55 second time step input. The ballistic trajectory calculation uses a Runge-Kutta approximation. The next portion is navigation error from the GPS inputs. The third is a manual input for a buffer on the landing distance. Finally, the last is a minor polygon edge buffer for the smoothing of the stay-in boundary.

2.4 Reliable Flight Termination Interface Unit

In order to provide Safeguard with the ability to interrupt power to the vehicle and ensure range containment, the RFTIU was designed and tested at NASA LaRC in support of the SAND competition. The overarching requirement was to design interface electronics that would support operations with Safeguard configured as an IFTS. The RFTIU interfaces with a wire cutter to disable motor power when Safeguard signals a flight termination. While designing the RFTIU, there were desires to have the ability to operate in a non-engaged or disarmed mode for developmental testing and integration with new vehicles. There was also a need to provide clear and robust operations for when Safeguard was to be used as an IFTS. This provoked four main requirements including: 1. Provide capability to know that Safeguard is ready to be armed with the vehicle on the flight line ready to launch, 2. Provide the capability to operate the IFTS in a test or bypass mode in order to mitigate risk to the vehicle and gain confidence in the system, 3. Minimize complexity, and keep weight to less than 8 ounces and 4. Ensure reliability of the IFTS for vehicle containment. Therefore, the RFTIU needed to be a simple, reliable, easily implementable and verifiable termination interface system that enabled risk mitigation to the vehicle for developmental testing and could be used for range containment. This would enable users to install and become proficient in the use of the RFTIU without risk to the vehicle.

During development of the RFTIU, the chosen path was to sever power only to the vehicle's propulsion system when signaled by Safeguard. This allowed for data collection to continue on the Pixhawk autopilot while the vehicle was in its post-termination trajectory. A vehicle architecture for the vehicle can be seen in Figure 8. Several options were considered in this design cycle that included high-power relays and electronically-triggered pyrotechnic wire cutters. Evaluation of the high-power relays indicated that they would tend to be large and heavy in order to accommodate the current required to fly the vehicle. Heat for these relays was also a potential issue, which would require a large heat sink. A single pyrotechnic wire cutter was evaluated for this design, which is shown in Figure 9. Each pyrotechnic wire cutter weighs only a few ounces. It can be fired by applying 1 amp current at 5 volts within a few microseconds. The pyrotechnic wire cutters were lab tested with representative power cables and yielded good results for the application of cutting the propulsion system power wire.

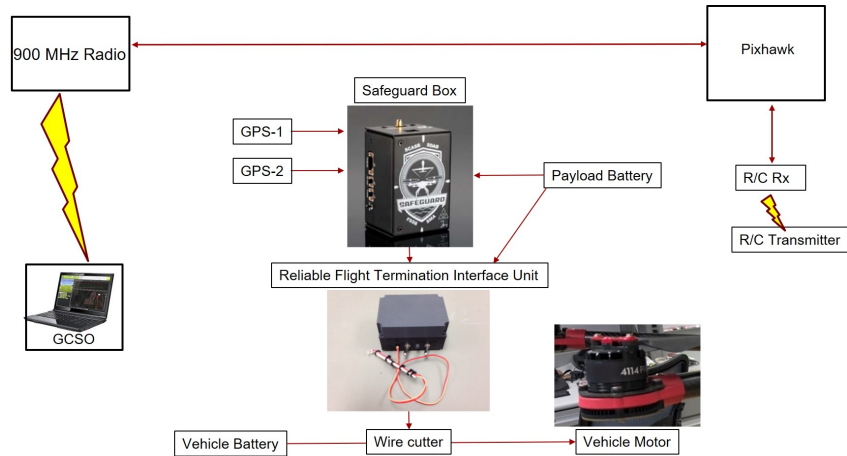

Figure 8. Block diagram of integrated Safeguard system.



Figure 9. Kirintec electronic wire cutter.

The schematic for the RFTIU can be seen in Figure 10. The RFTIU was mounted inside a 3D printed box as shown in Figure 11. Two system control toggle switches and two status indicator lights are also shown in Figure 11. The indicator light on the left is attached at the end of the power lead on the left of the box and illuminates when Safeguard is in operate mode and ready for arming. A short extension for this light was provided to allow it to be placed in the field of view of an on-board camera for developmental testing. This light goes out when Safeguard sends a terminate signal. The toggle switch on the left is used to arm or disarm the RFTIU. When in disarmed mode, the electronic relay used to fire the wire cutter is disengaged. The

toggle switch on the right controls whether current from the relay will flow through the wire cutter or will go through a LED light (bypass mode). The LED on the right illuminates when Safeguard has signaled a termination and the system is in bypass mode. Operating the RFTIU in bypass mode is useful to test and integrate the Safeguard system as an IFTS without unduly risking the vehicle or firing a wire cutter. A voltage regulator is included in the RFTIU to support a wide range of voltages. Testing was performed with a 4-cell lithium-polymer battery. Provisions have also been included to enable the wire cutter to be plugged into the interface box. This enables new wire cutters to be installed should one needs to be replaced. During the development flight tests, the RFTIU went through a total of 8 test flights that would trigger a termination, where 6 of the flights illuminated the light while in bypass mode and 2 the flights cut a representative wire that was not connected to the vehicle power.

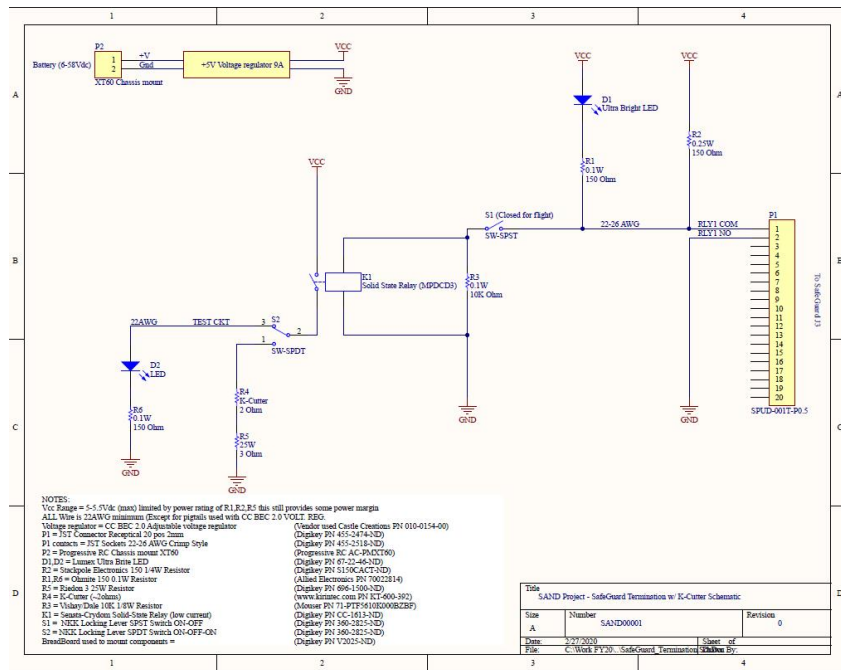

Figure 10. Schematic of the reliable flight termination interface unit.

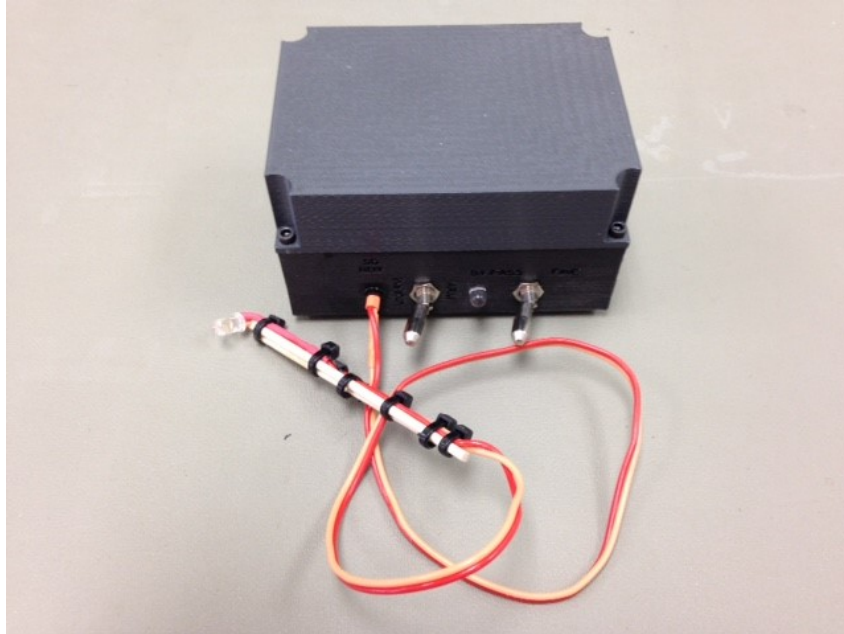

Figure 11. Reliable flight termination interface unit.

2.5 Tarot X6 Vehicle Termination

The first vehicle that was chosen to showcase an end-to-end test of a Safeguard initiated termination was a Tarot X6 vehicle. Within this flight plan, the vehicle was to complete a search pattern within the 50 by 50 meter flight area at a maximum of 5 m/s and 30 meters altitude. The vehicle was then programmed to travel towards the southwest boundary. Prior to the end-to-end test, the vehicle went through two practice runs utilizing the LED on the RFTIU to indicate a termination. Both of these tests indicated good results showing that flight within the 50 by 50 meter flight area was nominal and the terminations occurred at the expected locations. After the practice runs, the Safeguard system and RFTIU were fully armed with a wire cutter integrated into the vehicle power system. The manual settings that were input into Safeguard for the accelerations were 2 m/s^2 horizontally and vertically. The additional boundary buffer was set to 0 meters. On this flight day, the winds were estimated to be 8 kts from the east.

At the beginning of the flight, the vehicle operator manually raised the vehicle to 30 meters. When the vehicle operator switched from manual to automated flight, the vehicle surged unexpectedly in altitude. At this time, the vehicle went into a landing failsafe and attempted to descend without holding position. While descending, the vehicle drifted with the wind to the west and approached the stay-in boundary. The safety pilot attempted to regain manual control, however, Safeguard signaled a termination due to location and speed relative to the western stay-in boundary. The vehicle motor power was cut and descended in a free fall to the west. Prior to termination, the vehicle was descending at approximately 2.5 m/s and traveling horizontally with the wind at approximately 4.5 m/s ground speed, as recorded by

the Pixhawk. The trajectory results of this test from the primary and secondary navigation sensors from Safeguard and the Pixhawk can be seen in Section 3.1.

2.6 DJI S1000 Vehicle Termination

The second vehicle that was chosen to showcase an end-to-end test of a Safeguard commanded termination was a DJI S1000 vehicle. Within this flight plan, the vehicle was to complete a search pattern within the 50 by 50 meter flight area at a maximum of 5 m/s and 30 meters altitude, identical to the plan for the Tarot X6 vehicle. The vehicle was then programmed to travel towards the southwest boundary. Prior to the end-to-end test, the vehicle went through two practice runs utilizing the LED on the RFTIU to indicate a termination. Using the data that was collected from the Tarot X6 termination and the practice runs, a net was placed on the ground in a location where the vehicle was estimated to fall in hopes to protect the UAV for potential reuse and ensure data acquisition. At this time, the Safeguard system and RFTIU were fully armed with a wire cutter integrated into the vehicle power system. The manual settings that were input into Safeguard for the accelerations were 4 m/s^2 horizontally and 2 m/s^2 vertically. The additional boundary buffer was set to 0 meters. On this flight day, the winds were estimated to be 6 kts from the northeast, approximately in the same direction as the programmed vehicle termination trajectory.

During operations, the vehicle completed the search pattern and headed towards the southwest boundary. The vehicle approached the stay-in boundary and Safeguard correctly issued a terminate signal prior to reaching the edge of the stay-in boundary. The vehicle motor power was cut and the vehicle descended in a free fall to the southwest. Prior to termination, the vehicle was not descending and remained in level flight at approximately 30 meters. The vehicle was traveling horizontally at 4.9 m/s ground speed, as recorded by the Pixhawk. The trajectory results of this test from the primary and secondary navigation from Safeguard and the Pixhawk can be seen in Section 3.2.

3 Results of Vehicle Terminations

3.1 Post-processed Data - Tarot X6

During the post-processing of the data from the Tarot X6 termination, it was found that only partial data was collected on both the Pixhawk and the Safeguard unit. Safeguard buffers data prior to writing it to a log file. The last segment of data was not recorded because the Safeguard power was cut when the vehicle hit the ground. Therefore, in both of the data sets presented, the data associated with the vehicle will stop at an altitude greater than zero for the Tarot X6. In section 4, curve fits will be drawn in comparison to carry the trend of the vehicle to an altitude of zero and gather associated total distance traveled. This distance traveled can be compared to the estimated landing spot of the vehicle from the termination point. The latitude and longitude of the landing spot of the vehicle is estimated based

upon the trajectory that the vehicle was on prior to data loss and photographs with respect to the buildings that were nearby.

3.1.1 Pixhawk Data Collection

Using the Pixhawk data, the vehicle trajectory with respect to the overall stay-in boundary can be seen in Figure 12. The final estimated resting location of the Tarot X6 is indicated by the large “x”. The filled in square symbols represent data that was collected while in a terminated, non-propulsive state. The unfilled circle symbols represent the data of a fully powered vehicle leading up to the termination. The point of termination was determined by examining the power recorded in the Pixhawk. When the Pixhawk goes from a full electrical load to approximately 0 Watts of power, it has been decided that Safeguard has sent a termination signal to cut the power. From Figure 12, it can be seen that Safeguard appropriately terminated the vehicle to prevent the vehicle from crossing the stay-in boundary.

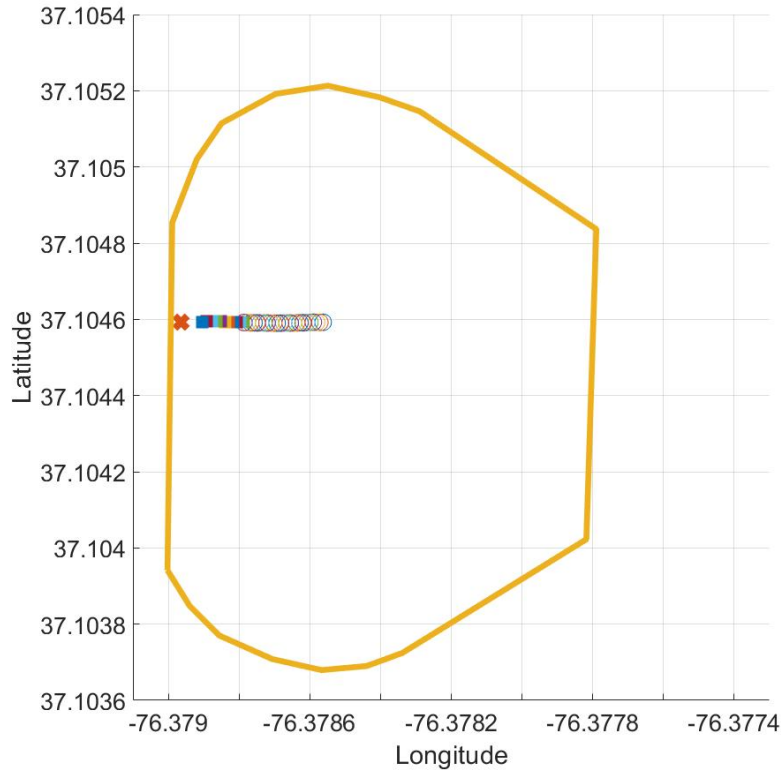

Figure 12. Pixhawk Tarot X6 trajectory in latitude and longitude.

In addition to the latitude and longitude data showcasing a successful termination and keeping the vehicle within the stay-in boundary, the data associated with the vehicle displacement and speed can be presented and is shown in Figures 13 - 17. The x-distance traveled is determined through the latitude and longitude data.

The y-distance traveled is from the recorded GPS altitude. The x-velocity is the ground speed recorded by the GPS sensors. Finally the y-velocity is the derivative of the change in altitude and time as recorded by the GPS. For the data collected, it can be seen that the vehicle did not achieve a terminal velocity within the 2.25 seconds of recorded data.

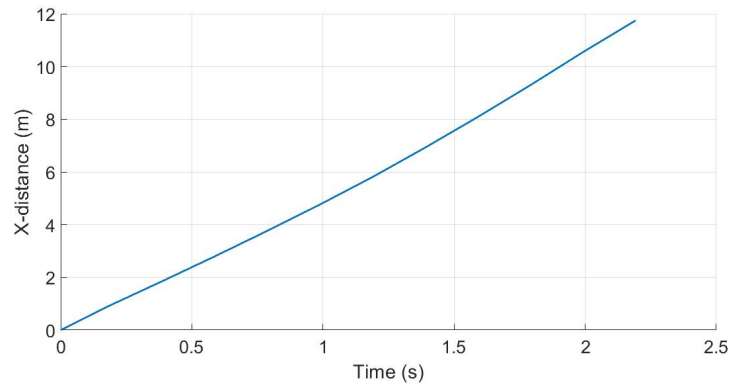

Figure 13. Pixhawk Tarot X6 x-displacement versus time in a free fall.

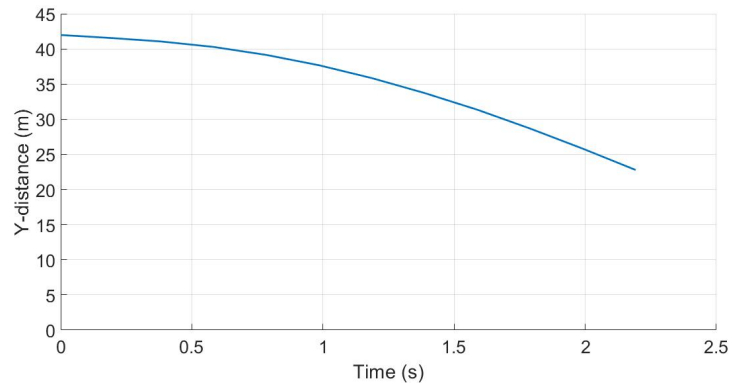

Figure 14. Pixhawk Tarot X6 y-displacement versus time in a free fall.

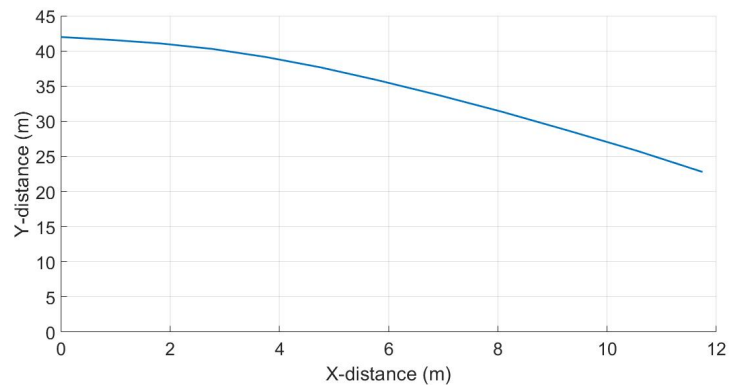

Figure 15. Pixhawk Tarot X6 y-displacement versus x-displacement in a free fall.

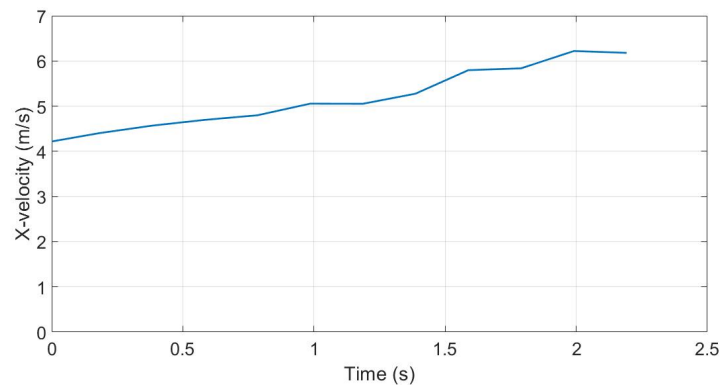

Figure 16. Pixhawk Tarot X6 x-velocity (ground speed) versus time in a free fall.

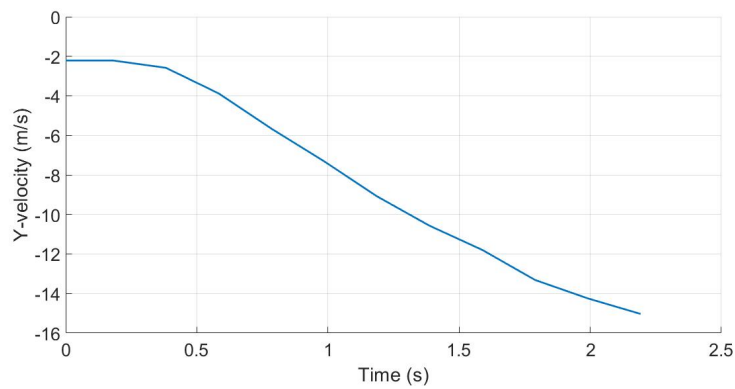

Figure 17. Pixhawk Tarot X6 y-velocity versus time in a free fall.

3.1.2 Safeguard Data Collection

Similarly to the Pixhawk data, the Safeguard collected data is GPS based. The GPS data for Safeguard can be plotted for both the primary and secondary navigation, which is shown throughout the plots. The blue solid line represents the data collected from the primary navigation, while the red dashed line is the secondary navigation data. The data in Safeguard is recorded at 5 Hz. Safeguard also stopped recording data approximately half-way through the free fall due to the loss of power after hitting the ground, preventing the data from being logged during the buffering. The same x and y distance traveled as well as x and y velocities can be seen in Figures 18 - 22. From these figures, it can be seen that the primary and secondary navigation do not deviate from each other significantly. The x distance traveled is determined by using the haversine formula with the latitude and longitude data. The y distance comes from the change in altitude. Both the x velocity and y velocity are derivatives of the respective distance traveled. The Safeguard unit collected a slight additional amount of data compared to the Pixhawk, which allows for an approximate terminal velocity to be seen. The terminal velocity in the y direction is approximately 16 m/s for the Tarot X6.

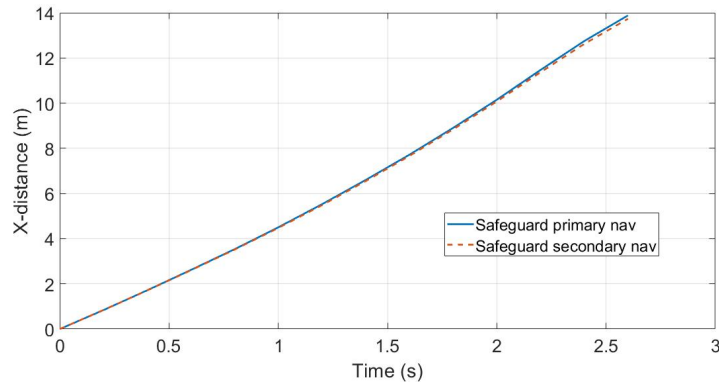

Figure 18. Safeguard Tarot X6 x-displacement versus time in a free fall.

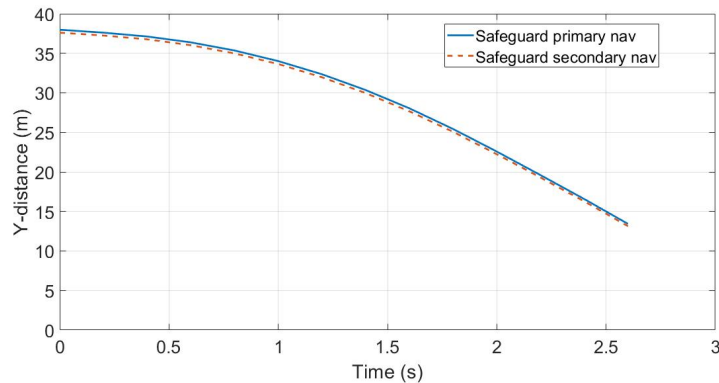

Figure 19. Safeguard Tarot X6 y-displacement versus time in a free fall.

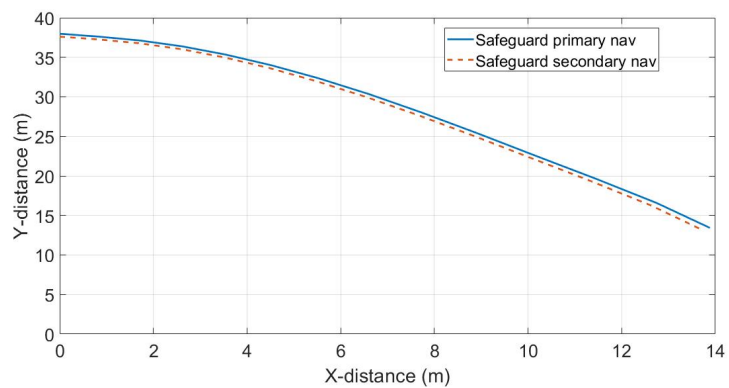

Figure 20. Safeguard Tarot X6 y-displacement versus x-displacement in a free fall.

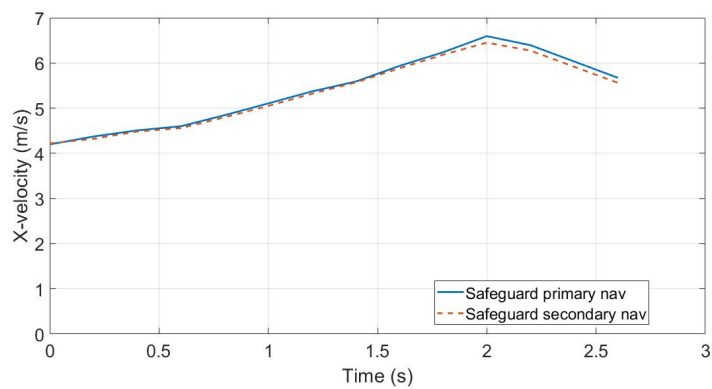

Figure 21. Safeguard Tarot X6 x-velocity (ground speed) versus time in a free fall.

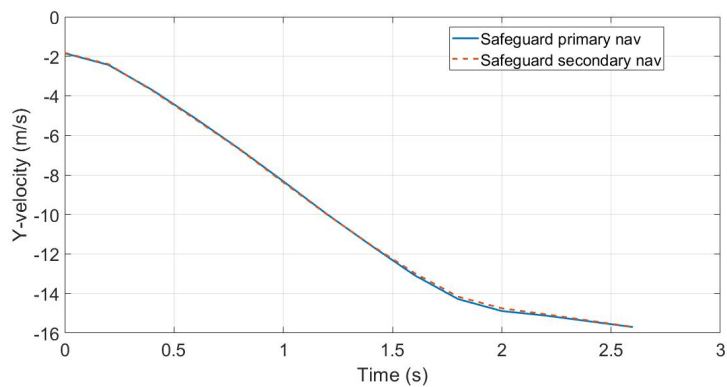

Figure 22. Safeguard Tarot X6 y-velocity versus time in a free fall.

3.2 Post-processed Data - DJI S1000

For the DJI S100 data set, both the vehicle data on the Pixhawk and the Safeguard data were collected in full. The DJI S1000 successfully engaged the safety catch net and prevented a severe impact, which may attribute to the protection of the Pixhawk and Safeguard unit to allow for data log writing. The following two subsections showcase the trajectory data collected during the post-termination free fall.

3.2.1 Pixhawk Data Collection

Similar processes were applied for determining the termination point based upon power in the data associated with the DJI S1000. The overall trajectory of the vehicle with respect to the stay-in boundary can be seen in Figure 23. With the additional 2 m/s^2 horizontal acceleration input into the Safeguard parameters, the vehicle stays even further into the boundary as compared to the landing location of the Tarot X6. Additionally, Figures 24 - 28 show the associated GPS data recorded by the Pixhawk for the post-termination free fall. For this data set, the full termination data can be seen and allows for a better prediction of the trajectory a vehicle would fall going 5 m/s at 30 meters altitude for this specific vehicle and wind conditions. The DJI S1000 traveled 15 meters from this altitude and speed over the course of 3 seconds, while traveling with the an estimated 6 knots of winds. The terminal velocity of this vehicle, as determined by the derivative of y-distance, can be predicted to be approximately 17 m/s .

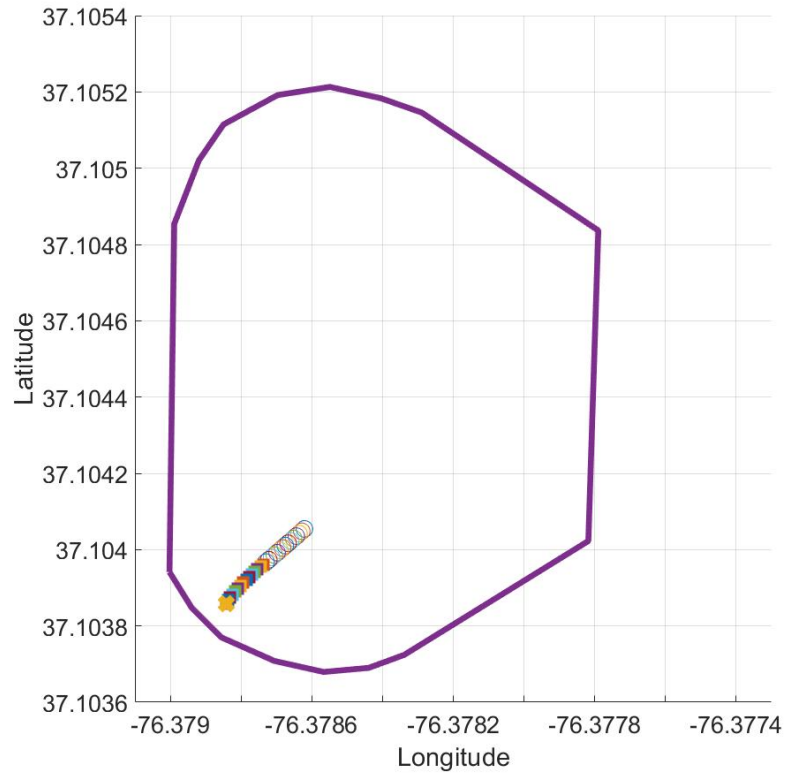

Figure 23. Pixhawk DJI S1000 trajectory in latitude and longitude.

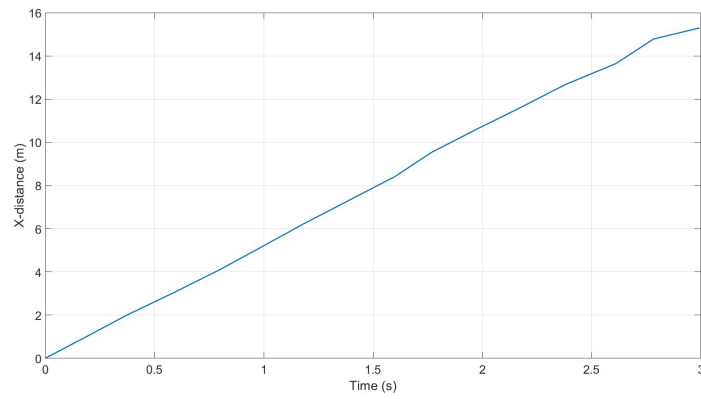

Figure 24. Pixhawk DJI S1000 x-displacement versus time in a free fall.

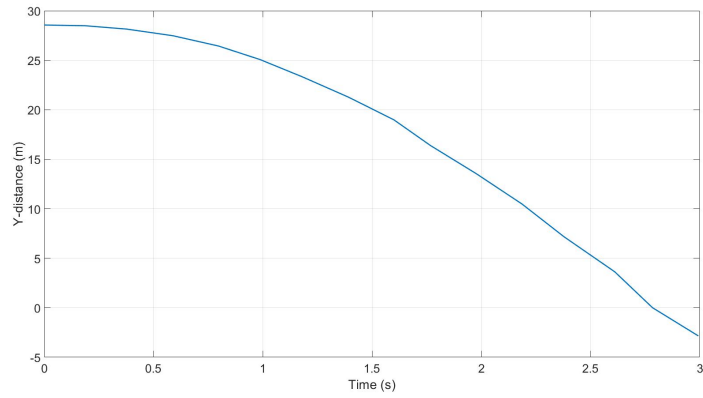

Figure 25. Pixhawk DJI S1000 y-displacement versus time in a free fall.

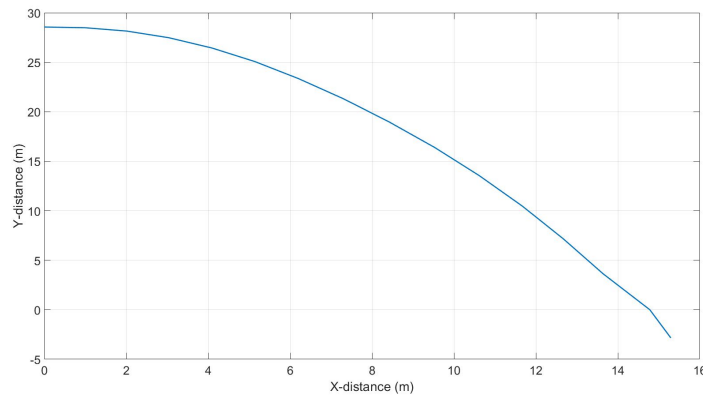

Figure 26. Pixhawk DJI S1000 y-displacement versus x-displacement in a free fall.

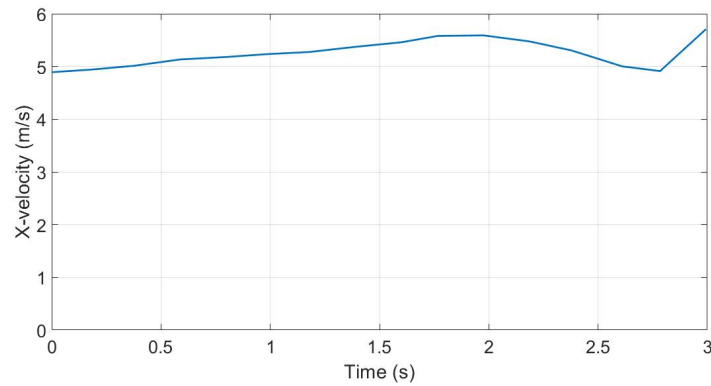

Figure 27. Pixhawk DJI S1000 x-velocity (ground speed) versus time in a free fall.

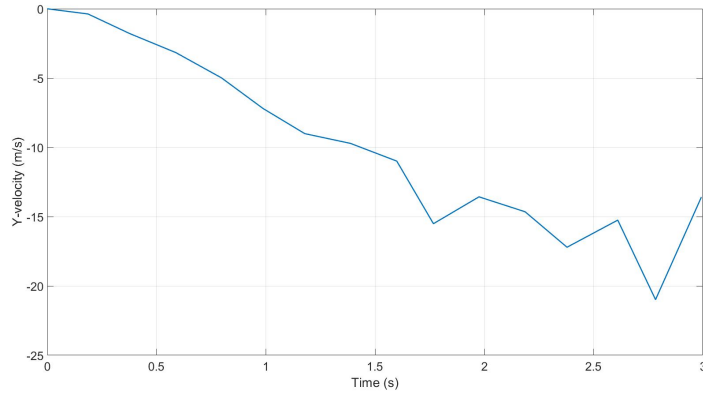

Figure 28. Pixhawk DJI S1000 y-velocity versus time in a free fall.

3.2.2 Safeguard Data Collection

Safeguard also had success in collecting all data to the ground, which was enabled due to retention of battery power throughout the termination and facilitated by catch net engagement. The same data for the DJI S1000 for both the primary and secondary navigation is presented in Figures 29 - 33. It can be seen that there is more deviation between the primary and secondary navigation with respect to the altitude reading. Similarly to the Pixhawk data, Safeguard recorded vehicle travel to be approximately 15 meters and reached a terminal velocity of 17 m/s.

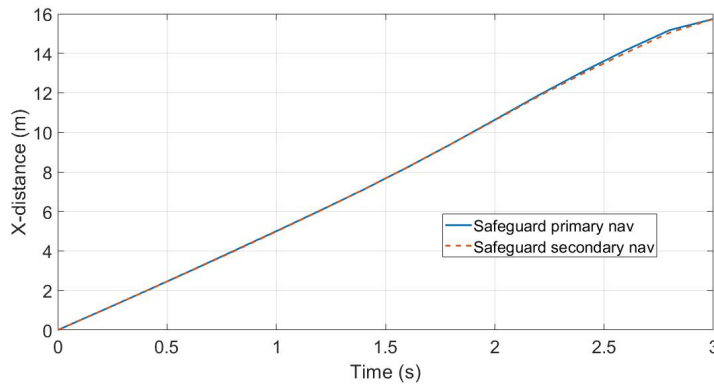

Figure 29. Safeguard DJI S1000 x-displacement versus time in a free fall.

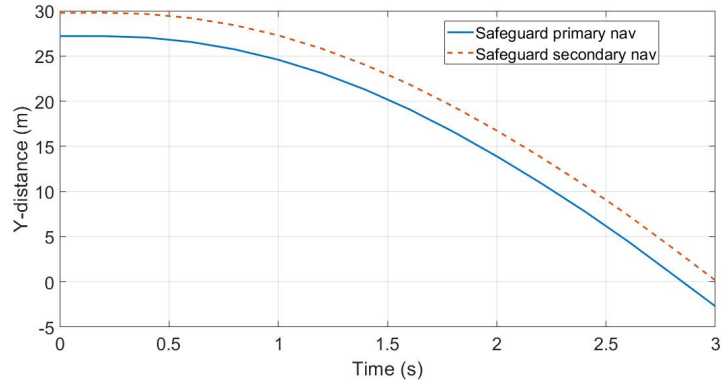

Figure 30. Safeguard DJI S1000 y-displacement versus time in a free fall.

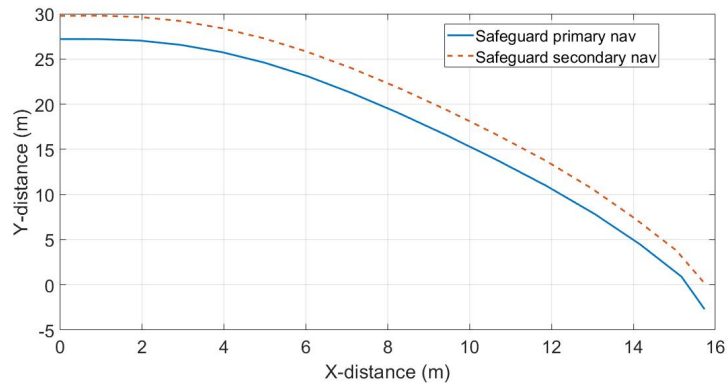

Figure 31. Safeguard DJI S1000 y-displacement versus x-displacement in a free fall.

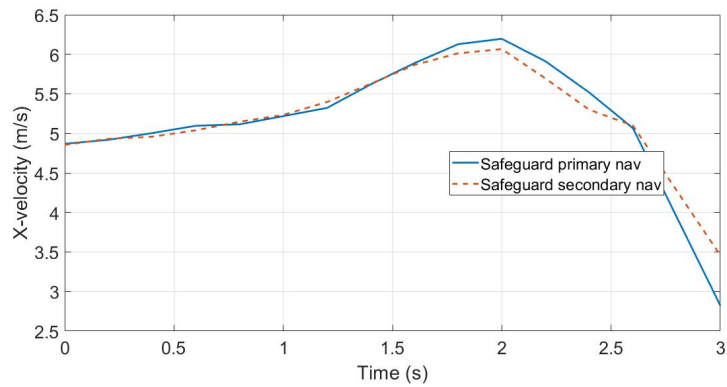

Figure 32. Safeguard DJI S1000 x-velocity (ground speed) versus time in a free fall.

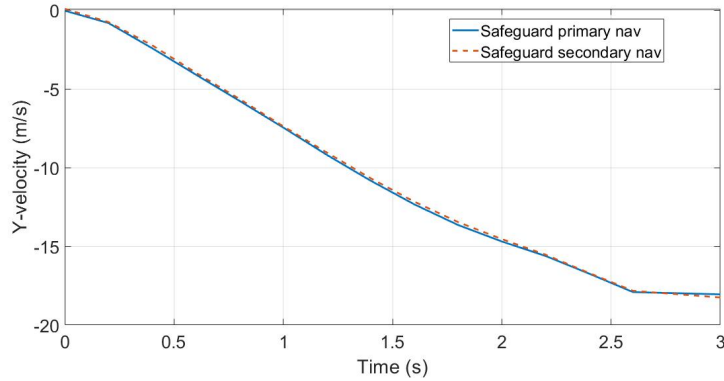

Figure 33. Safeguard DJI S1000 y-velocity versus time in a free fall.

4 Aerodynamic Prediction Analysis

Throughout this testing, the main configuration parameters that were being investigated in the Safeguard software were the horizontal and vertical accelerations applied before the vehicle dynamics calculations (applied as a worst case condition over the Safeguard execution time of 0.55 seconds) and the landing buffer. The team attempted to vary these to account for forces applied on a vehicle that are not included in a pure ballistic trajectory calculation, like lift from the propellers while they are spinning down, drag on the vehicle, and any external forces such as wind. At the end of the flight testing, it was desired to have either a landing buffer value to account for winds and aerodynamic effects or a set of acceleration terms to capture worst case scenarios given worst case scenarios at maximum initial conditions. For the SAND competition, since a maximum altitude and speed were defined, a landing buffer was more desirable.

4.1 Ballistic Trajectory Approach

With the trajectory data from two vehicles while in different wind conditions, a generalized wind and vehicle aerodynamic contribution to the trajectory could be estimated. In order to look at the data from the Tarot X6, trend lines were drawn down to an altitude of zero in order to estimate the total distance that was traveled post-termination. In addition, this distance was checked with the estimated landing location of the vehicle with respect to the termination point. The trend lines were considered appropriate by this method. In addition to the trajectory data from the Pixhawk and primary and secondary navigation systems of Safeguard, a pure ballistic trajectory with no additional acceleration, a ballistic trajectory with the accelerations that were used on Safeguard during the flight, and a ballistic trajectory with an appropriate vertical and horizontal acceleration to match the data that was collected are added to the plot. The ballistic trajectory with acceleration is computed similarly to Safeguard, where the accelerations are applied to the initial velocity over a 0.55 second time step. Instead of using Runge-Kutta approximations, the exact solution will be calculated and plotted with the trajectory data from the

on-board recorders. The average initial altitude and horizontal and vertical velocity between the three data sets will be used as initial conditions for each of the ballistic trajectory calculation.

The co-plots of the actual data for the Tarot X6 termination can be seen in Figure 34. Since the data at impact was lost for this flight, curve fits were added to the plots that allow for the trend of the data be applied all the way to an altitude of zero meters. The three ballistic trajectories from the point of termination are also included, where the zero acceleration curve represents a pure ballistic trajectory, the flown acceleration represents the acceleration parameters that were put into Safeguard for the flight, and the adjusted acceleration, which represents a set of acceleration parameters that could match the total distance traveled in the actual data. The initial conditions for the ballistic trajectories for the Tarot X6 included the average of the actual data, which yielded 39.2 meter starting altitude, 4.2 m/s horizontal velocity, and -1.96 m/s vertical velocity. Reiterating the accelerations that were flown listed in section 2.5, both the horizontal and vertical accelerations were 2 m/s^2 . In order for the ballistic trajectory portion of the distance calculation to be approximately equal to the actual data curves, the accelerations should have been 4 m/s^2 horizontally and 2 m/s^2 vertically given the initial conditions above and a 8 kts wind. This is shown by the adjusted acceleration ballistic trajectory plot. In this case, the landing location would have been approximately 17.9 meters.

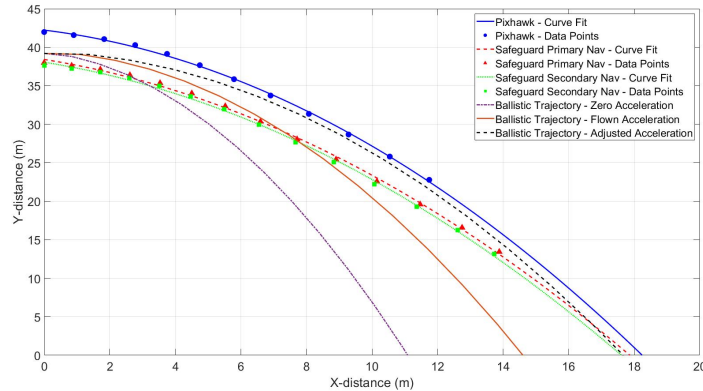

Figure 34. Tarot X6 termination trajectory.

The co-plots of the actual data for the DJI S1000 termination can be seen in Figure 35. Additionally, the three ballistic trajectory curves are also plotted, however, with different acceleration parameters for the flown and adjusted acceleration cases as compared to the Tarot X6. The initial conditions of the DJI S1000 for the ballistic trajectories included the average of the actual data, which yielded 28.5 meter starting altitude, 4.9 m/s horizontal velocity, and 0 m/s vertical velocity. Reiterating the accelerations that were flown listed in section 2.6, the horizontal acceleration was set to 4 m/s^2 with the vertical acceleration at 2 m/s^2 . In order for the ballistic trajectory estimation to be approximately equal to the actual data curves, the accelerations should both have been 2 m/s^2 horizontally and vertically

given the initial conditions above and a 6 kts wind. This is shown by the adjusted acceleration ballistic trajectory plot. In this case, the landing location would have been approximately 15.2 meters.

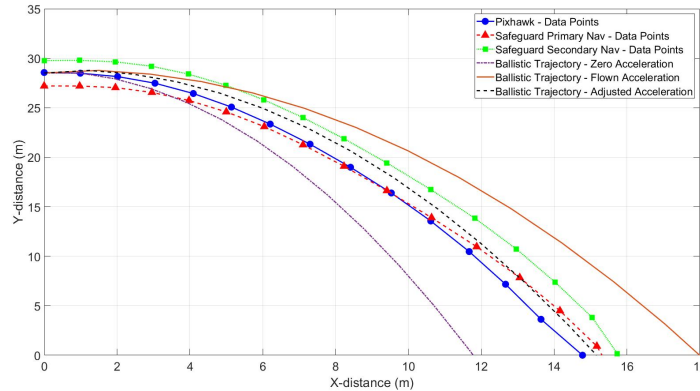

Figure 35. DJI S1000 termination trajectory.

In addition to looking at the comparison of the plots and recommending the acceleration parameters in Safeguard that would match the actual data of the two flights given the initial conditions and wind speed, it would be important to estimate how the wind influences the vehicle in general. In this effort, it is desired to obtain how many meters the wind drifts the vehicle per knot of wind. This can be done by comparing the final distance traveled by the vehicle to the pure ballistic trajectory with no acceleration. This difference in distance represents the aerodynamic effects, including wind, drag, and lift from propeller spin down. For the Tarot X6, the vehicle traveled 6.14 meters further than the zero acceleration ballistic trajectory calculation. For the DJI S1000, the vehicle traveled 3.10 meters further than the zero acceleration ballistic trajectory calculation. Taking into account the difference in wind (8 kts for the Tarot X6 and 6 kts for the DJI S1000) and starting altitude (39.2 meters for the Tarot X6 and 28.5 meters for the DJI S1000), if the vehicle fell from the same altitude, an approximation for distance traveled for wind effects can be computed. The Tarot X6 would have approximately traveled 0.59 meters/knot of wind horizontally more than the zero acceleration ballistic trajectory, if adjusted to a 30 meter altitude. The DJI S1000 would have approximately traveled 0.54 meters/knot of wind horizontally more than the zero acceleration ballistic trajectory, if falling from 30 meters. An averaged horizontal distance traveled per knot of wind between the two flights is 0.57 meters/knot. This accounts for the worst case scenario, where the vehicle is traveling in the direction of the wind with an altitude of 30 meters, horizontal velocity of approximately 4.5 m/s and vertical velocity of approximately 0 m/s. Therefore, using this method, in preparations for the SAND competition, an additional buffer from the zero acceleration ballistic trajectory case should be 8.6 meters to account for a 15 knot wind (the maximum competition wind limit) in the direction of the vehicle at an altitude of 30 meters, while the vehicle is traveling 4.5 m/s horizontal. With the addition of the pure ballistic trajectory

calculation, a total distance from the stay-in boundary would be 21 meters. A 10 meter landing buffer would provide 16% margin for the max altitude, speed, and wind conditions for this method.

4.2 AirSTAR Drift Prediction Tool Approach

Additionally, another approach was taken with the attempt to match the data for both vehicles in order to determine values for vehicle parameters, including drag coefficient and cross-sectional area. Then a Monte Carlo analysis varying wind speeds, initial conditions, and vehicle parameters could be performed. This prediction tool was previously used for the AirSTAR program to assess the drift characteristics from wind and impact point of a terminated flight [6]. One caveat to the AirSTAR drift prediction tool is the assumption of a steady-state free fall trajectory, which is not representative of the post-termination free fall examined in this report. For both the Tarot X6 and DJI S1000, the initial condition parameters used were from the Pixhawk. A surface area was calculated based upon the tip to tip cross-section of the motors. The area supported the estimated drag calculation along with the estimated 17 m/s terminal velocity from both of the vehicles. The wind field in the prediction tool was established to be constant throughout altitude and was pointed in the direction of the vehicle travel. This method also allowed for the addition of the initial descent velocity that occurred with the Tarot X6. Within the impact predictor tool, the vehicle parameters that were time related were altered until the total distance traveled, terminal velocity of descent and time approximately matched the collected data. The results for the Tarot X6 and DJI S1000 can be seen in Figures 36 and 37, respectively. The initial conditions were then put to a constant 5 m/s horizontal velocity with no descent at a 30 meter altitude. The wind was also set to 15 kts to consider a worst case scenario. For the Tarot X6 vehicle parameters, the distance traveled by the vehicle in this worst case scenario was approximately 20 meters. For the DJI S1000 vehicle parameters, the vehicle was estimated to travel 18 meters. Both of these numbers determined by the AirSTAR prediction tool approach are comparable to the ballistic trajectory approach of a total of 21 meters. A variation in conditions were also performed in a Monte Carlo to see the impact of two parameters to gather the potential variation in competitors vehicles and wind conditions. This process was done for both the Tarot X6 vehicle parameters and DJI S1000 vehicle parameters with uniform distributions. The two main parameters of interest were the estimated drag coefficient for a vehicle and the wind in order to consider gusts. The drag was varied plus/minus 20% from the nominal value. The wind was varied plus/minus 2 knots from the nominal value. At a maximum, using the Tarot X6 prediction, the Monte Carlo analysis produced a horizontal distance traveled of 22.5 meters, which can be seen in Figure 38. Removing the distance covered by the pure ballistic trajectory, 12.4 meters, indicates that the additional buffer should be 10 meters in order to capture the 20% variation of vehicles and 13% deviation in wind. Both approaches confirm a 10 meter landing buffer distance would be conservative for the maximum flight conditions expected in the SAND competition.

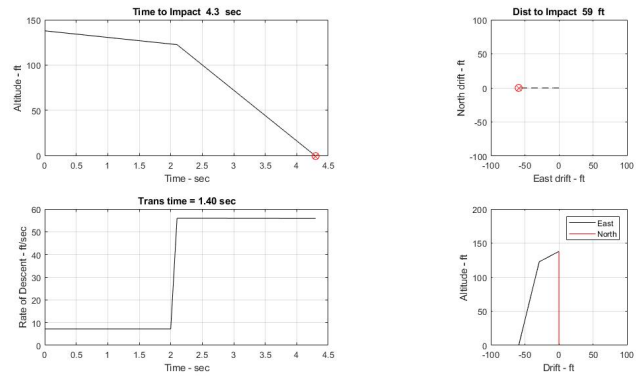

Figure 36. Prediction tool match of the Tarot X6 data.

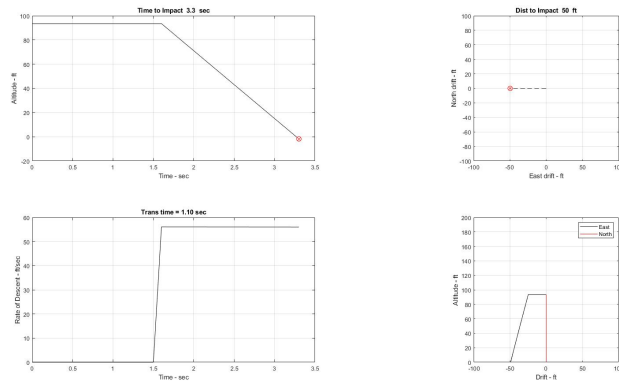

Figure 37. Prediction tool match of the DJI S1000 data.

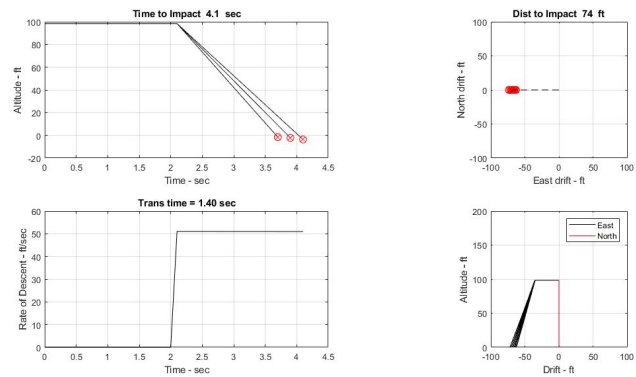

Figure 38. Monte Carlo analysis for the Tarot X6 with variation of coefficient of drag and wind.

5 Safeguard Configuration for SAND

The Safeguard system is configurable through a set of files read by the software at initialization. The following proposed parameters were based upon the competition site at the Langley Speedway in Hampton, VA. The flight area and range containment (stay-in zone) are shown in Figure 4. The flight area is slightly offset from the center in the overall range containment area to maximize the altitude and recommended flight speed for the competition. The configuration files are described below:

- SWConfig.txt – General configuration settings for the software. Parameters which control when the system generates warnings for boundary and altitude violations and limit settings for warnings and faults are defined in this file.
- StayInZone.txt – Defines the stay-in zone polygon and altitude limit. The stay-in zone polygon defines the range containment area for the flight.
- StayOutZones.txt – Defines the stay-out zone polygons. Multiple stay-out zones can be defined in the file.
- FlightPlan.txt – Defines the flight path. The flight path is used for a flight path deviation warning.
- VehicleDynamics.txt – Vehicle parameters and settings which define the constants used for the vehicle dynamics calculations.
- VN200Config.txt – Defines data packet persistence parameters used for checking data from the VN200 Navigation unit. Fault errors are reported if the packet checks persist for the specified persistence limits. Optional speed and bank angle warnings can be defined.

Rationale for each of the parameter settings was documented in a spreadsheet and reviewed by the team. The most significant decisions were the selection of the warning boundary multiplier and using the landing buffer distance to account for wind and aerodynamic effects after a vehicle has been terminated. For the previous SAND flight tests, the lateral and vertical acceleration terms in the vehicle dynamics files were used in an attempt to account for wind effects. Analysis of the flight data indicated the acceleration terms should be used for their intended purpose; to account for an unexpected acceleration at termination. Instead, wind and aerodynamic effects are accounted for in the landing buffer. The landing buffer is set to 10 meters to account for a worst case 15 knot wind with a vehicle terminating at its maximum altitude and speed. The analysis described in section 4 was instrumental in understanding the aerodynamic effects post-termination. The parameter settings provided margin for range containment while reducing the number of warnings that competitors would experience if they fly within the altitude and speed limits specified for the competition. If competitors flew within recommended altitude and speed limits, they should receive minimal, if any, boundary warnings for flying too close to the range containment (stay-in zone) boundary. If they fly higher or faster than the

recommended limits, the competitors should expect to receive warnings from Safeguard at the edges of the flight area. Only in extreme altitude or speed conditions would a vehicle be terminated within the flight area. Future SAND flight tests were planned to have been flown at various altitudes, speeds, and flight paths, using the proposed configuration, to validate expected warning and termination points for the competition. Configuration file parameters would be deemed acceptable or changed to provide the desired results.

6 Scoring System

In addition to the flight testing, the following approach for the scoring system to the SAND competition was proposed. Competitors would earn points for the SAND competition through 2 primary assessment areas: qualitative and quantitative performance. Qualitative points would be awarded from documentation provided to support the application process, flight operations and safety, the Safeguard business case, and the workmanship of the vehicle. Quantitative points would be earned through a combination of performance of a nominal search pattern (using a generic virtual sensor), identification, geolocation, and surveillance of targets of interest, integration of Safeguard data into the autopilot, and finally support to having real-time scoring during the team's flight. Safeguard would be used for range containment as an IFTS as well as a vehicle tracker (collecting altitude, latitude and longitude) for official scoring. Safeguard data would be downloaded and post-processed after each flight. Competitors would have at least one and up to three rounds, pending weather conditions and competitor level of participation, to generate a quantitative score. The highest of the quantitative scores would be used for the final score. Overall, the qualitative and quantitative portions of the score were to be approximately 50% qualitative and 50% quantitative.

6.1 Qualitative Score

1. Vehicle documentation

The competitors would be awarded points regarding the completeness and accuracy of the provided vehicle documentation in their application.

2. Flight operations and safety

In order to be authorized to operate unmanned aircraft system (UAS) as part of the SAND competition competitors would need to successfully pass the operational readiness review. This review performs an assessment of the competition team's capability towards meeting all specified requirements and ensuring safe operations. Teams would also prepare a Flight Test and Operations Safety Report (FTOSR) document, which would include: vehicle description, modifications performed from the stock vehicle to support SAND operations, vehicle schematics, instrumentation, summary of supporting development testing, crew requirements and qualifications, pre-flight procedures, airworthiness, flight test procedures, crew communications, and hazard analysis. Note: the hazard analysis would be focused on hazards particular to a competitors vehicle. A basic set of SAND competition hazards would

be provided.

3. Safeguard business case

The Safeguard business case would be evaluated upon the level of Safeguard integration, new and unique applications, impact towards integration of UAS into the NAS, and potential improvements that could be accumulated for the Safeguard system.

4. Vehicle workmanship

This element of score would be based on the quality of the workmanship for the competition vehicle and assess how well systems are installed, wired, and how the basic vehicle is put together. An example would be how the various wires are sized with only minimum length and properly secured to the vehicle to minimize electromagnetic interference effects.

6.2 Quantitative Score

The quantitative score would consist of a series of tasks that require different optimum altitudes and/or vehicle speeds. The basic search task is designed to influence the competitors to fly at higher altitudes and potentially higher speeds than detection and geolocation for a target of interest. Extended surveillance of targets of interest would benefit from lower and potentially slower speeds. In order to maximize the quantitative points, the competitors would need to perform analysis, effectively model their vehicle and potentially perform simulation testing in addition to performing developmental and practice flights. Competitors were proposed to have a total of 10 minutes to complete their flight with an additional 5 minutes of preparation time on the ground (15 minutes total). Competition points would only be awarded for fully-autonomous vehicle operations. Vehicles would need to takeoff and land autonomously as well as perform the search and surveillance tasks, including identifying and changing course for a target of interest. Overall, the scoring system was designed to be able provide significant differentiation of competitors who have the expertise and prepared appropriately for the SAND competition.

1. Basic search of competition area

The competition field would be discretized into a series of approximately 4.5 by 4.5 meter cells. A competition field of 50 by 50 meters results in 121 individual cells. Each cell has a maximum nominal value that would be provided to the competitors before the competition. Some cells have higher maximum points simulating locations of interest in order to influence competitors to search that area longer. The overall score for completing the search pattern is to scan the entire search area, with a preference to those areas that have higher values. In each corner, the 9 by 9 meter cluster of cells would have zero values and would gain no points if they overfly them. Competitors would earn scores for performing a search of the cells using an assumed virtual sensor, which would point directly to the ground from the reported vehicle position. For each instant of Safeguard data, a partial score is accumulated for any cell within the virtual sensor field of view up to the maximum value for each cell.

In order to collect all points for a single cell, the competitor's vehicle would require multiple seconds with the cell in the field of view on a single pass and/or multiple passes. Once the maximum points of a cell are collected, the search score from that cell will stop accumulating points regardless if the cell is still in the field of view of the virtual sensor.

The points collected by the virtual sensor would be defined through a series of parameters such as field of view (FOV) and sensitivity. Adjustment of the virtual sensor FOV would be set to require approximately 7 minutes of flight over the competition area in optimal conditions. The accumulated score is adjusted by a scale factor of 100% at the center of the FOV to 0% at the edge of the FOV. More than one cell can be in view of the virtual sensor, but those cells toward the outside of the FOV will accumulate a fraction of the incremental score versus those at the center of the FOV. Likewise there is a nominal altitude range where the full incremental score is accumulated. The highest nominal search altitude is 30 meters and maximum search altitude is set to 40 meters. Above the nominal altitude, there is a buffer zone (between 30 and 35 meters), where competitors would only receive 1/2 of the nominal points. This buffer zone encourages competitors to fly under the nominal altitude limit of 30 meters. If they fly over the 1/2 point buffer zone (i.e. 35 meters or higher) they will not receive any points. At this time, the minimum altitude is established at 10 meters AGL. Below 10 meters the competitors would not earn any points.

2. Targets of interest

Developing, advancing, and demonstrating the efficacy of UAS to aid in disaster response efforts is included as a major objective of the SAND competition. To meet this objective, several simulated targets of interest would be placed on to the playing field. The competitor's aircraft would accumulate additional points if the simulated targets of interest can be detected, identified, geolocated, and surveilled. The locations of the targets would not be known to the competitors before vehicle launch and efforts would be taken to keep the targets of interest out of direct line of sight of the competitors. The cells that contain the targets of interest would be worth an order of magnitude more than the nominal value provided to the competitors. If a competitor's vehicle detects and identifies a target of interest, the objective would be to hover directly over the cell to accumulate the additional points for that cell. It is up to the competitors to decide how much time to dedicate to the surveillance versus searching the rest of the field. The target of interest points are accumulated in a similar fashion to the nominal search grid in that the incremental points are inversely scaled by the distance from the center of the virtual sensor FOV and altitude regions.

The targets of interest that were proposed include mannequins, water-filled pools, and UV emitters to simulate the proposed post-disaster scenario for the SAND competition. Mannequins with nominal clothing would be placed on the field in a lying position to represent a person who is incapacitated and needs assistance. This target of interest would require the competitor's aircraft to detect and identify an incapacitated person who needs medical attention. Children's pools would be used to test the capability of competitor's aircraft of identifying an area

under water. Multiple pools could be used, however, only a fraction of them would be full of water. A UV emitter would be used to simulate a potential downed power line that may still be sparking. The UV emitter would be placed on a tripod and positioned in the competition field out of direct competitor line of sight. Alternatively, multiple UV emitters will be placed on to the competition field with only one being powered for a given time. Post-flight scoring can be scored with or without targets of interest. The ground station display would show the amount of points received for overflight only, for TOIs only, and then the total score of both overflight and TOIs. In this way, competitors can view the scores received for cell overflight and TOIs separately to gauge how well they performed.

3. Autopilot integrated with Safeguard

Competitors would earn points if it can be demonstrated that their vehicle's autopilot is integrated with Safeguard and can receive real-time data. Safeguard provides parameters such as range and bearing to the closest boundary and if the vehicle is in a warning zone. There would be different levels of integration in order to gain additional points. The first level of integration would utilize the additional warning relays within Safeguard. The use of the warning relays in the autopilot could allow for adjustment of the altitude and speed of the vehicle as a response to warnings. The second level of integration would use the serial interface of Safeguard. The use of the serial interface of Safeguard could allow the autopilot to minimize or avoid warnings through altitude and speed changes. Either level of integration could be displayed by relaying the information to the ground during flight or produce post-flight data logs that show receipt of Safeguard messages and data.

4. Providing flight data for real-time scoring

Unofficial scores would be calculated from the vehicle's telemetered data to the ground control station. Competitors would earn points by sending Mavlink UDP packets from the vehicle ground control station to the SAND scoring distribution computer. Competitor's vehicle position would be integrated with an Augmented Reality (AR) / Virtual Reality (VR) system and displayed to the competition audience. In addition, the current unofficial quantitative score from the search task would be displayed along with graphical progress of searching the competition area.

6.3 Pre-flight Scoring System Requirements

There is importance in defining certain variables prior to the flight that would affect the overall score. Since these variables could be changed for any flight, these configurable variables were established in a SAND configuration file. This file was read by the ground station and included the following variables: changes in latitude/longitude, acceptable minimum/maximum altitude, acceptable minimum/maximum latitude, acceptable minimum/maximum longitude, and the maximum altitude limit for the 1/2 point buffer zone. Also, there are multiple Safeguard configuration files that have elements that could affect scoring, such as maximum acceleration in the horizontal and vertical directions.

Within the scoring system interface, the sensor angle can be adjusted before

scoring. The recommended sensor angle for FOV is between 5-7 degrees. Larger FOVs would reduce the challenge for competitors by flying slowly at a higher altitude to collect a large portion of the cells to accumulate points. Smaller FOVs would not be feasible to ensure competitors are able to accumulate points within a 10 minute flight. Finally, another pre-flight configuration variable on the scoring system user interface is for the TOIs. TOI locations can be changed prior to any flight by adjusting the latitude and longitude coordinates.

6.4 Scoring System Quantitative Data Collection

In an effort to assess the feasibility of the scoring system algorithm, the collected GPS data from Safeguard for the test flights discussed prior were utilized with further flight testing proposed directly related to assessing the scoring system and real-time scoring system logistics. For many of the flights that were performed, the data files could be run through the scoring system tool. However, these flights were not optimized for the highest score and were primarily used to access the functionality of the tool. The sample grid for the scoring system tool can be seen in Figure 39. Each cell has a maximum score and once achieved, prevents the competitor from accumulating any more points for that cell. The 100 point cells near the edges of the competition area represent higher risk areas for the post-disaster scenario and encourage competitors to fly as close to the edge as possible, while staying within the boundary limits. The points are tapered down towards the center and indicate lower risk areas for the post-disaster scenario. Additionally, the targets of interest are highlighted in various colors to indicate that the maximum number of points can exceed what is displayed in the cell. In Figure 39, the red cell represents the mannequin, the blue cell represents the water, and the green cell represents the UV emitter. The locations for the targets of interest can be changed prior to any flight to ensure that no competitor has an unfair advantage. The majority of the flight tests performed did not contain a loiter point and therefore only accessed the feasibility and functionality of the tool with regards to the search pattern. A sample search pattern without targets of interest can be seen in Figure 40. Different colors within the flight path indicate whether the vehicle was at an acceptable altitude to collect points. With a dark blue flight line, the vehicle was below the altitude necessary to collect points. This occurred at the beginning and end of each flight when the vehicle was manually moved into and out of the operational flight area. With a green flight line, the vehicle is at an acceptable altitude. Gray lines indicate the vehicle was outside of the specified latitude or longitude limits to collect points and therefore the scoring system calculations were not performed. Cells that are outlined in a light blue indicate that the points for that cell are maxed out and the competitor would no longer collect any points for that cell. If cells with a maximum value of 0 are indicated as maxed out, the UAV is getting too close to the boundary. This visual discourages competitors from flying outside the designated area. In addition, it can be seen that the sensor FOV angle can be adjusted within the tool. The number of cells that collected the maximum number of points as well as the total calculated score is displayed within the tool also.

K	0	0	100	60	40	20	40	60	100	0	0
J	0	0	100	60	40	20	40	60	100	0	0
I	100	100	100	60	40	20	40	60	100	100	100
H	60	60	60	60	40	20	40	60	60	60	60
G	40	40	40	40	40	20	40	40	40	40	40
F	20	20	20	20	20	20	20	20	20	20	20
E	40	40	40	40	40	20	40	40	40	40	40
D	60	60	60	60	40	20	40	60	60	60	60
C	100	100	100	60	40	20	40	60	100	100	100
B	0	0	100	60	40	20	40	60	100	0	0
A	0	0	100	60	40	20	40	60	100	0	0
	1	2	3	4	5	6	7	8	9	10	11

Figure 39. Sample scoring grid for the SAND competition.

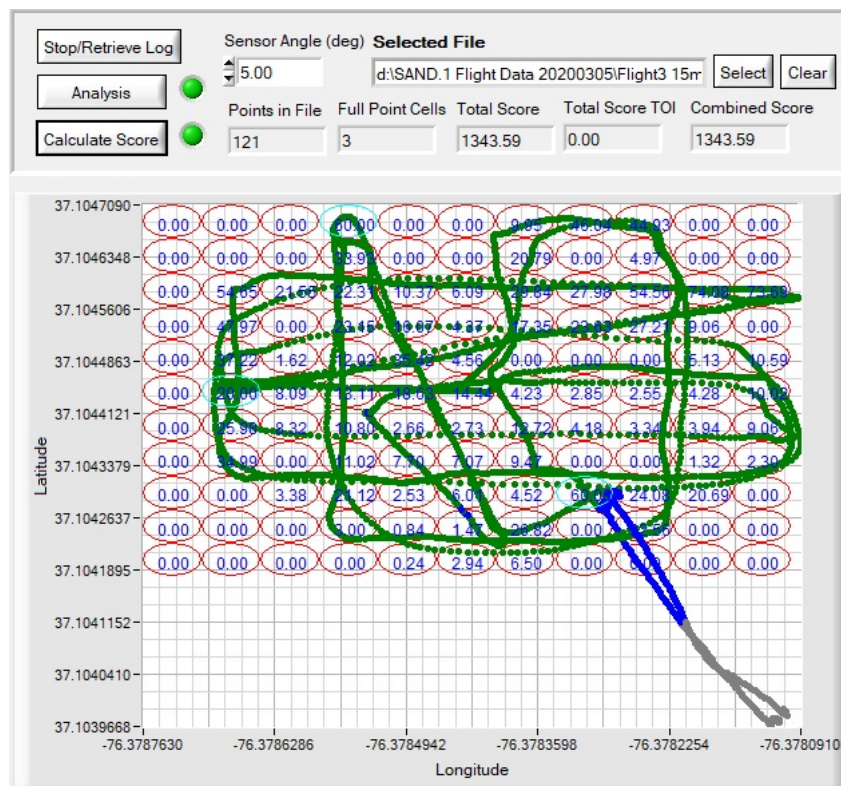

Figure 40. Sample scoring grid flight for the SAND competition without target of interest.

After the two terminations were completed, feasibility of maximum run times and simulated targets of interest were added to the flight testing. These tests heavily

informed the development of the scoring system using the maximum flight parameters allowed, including altitude, speed, and total flight time. Two flights that were approximately 10 minutes each, simulated identification of a target of interest and loitered in a single location at a lower altitude before climbing to a higher altitude and finishing a search pattern in an attempt to maximize points. The 3D visuals of these paths collected by Safeguard can be seen in Figures 41 and 42. These figures follow the same color scheme as discussed before of green being Safeguard in a neutral state, yellow for a warning state, and red for a termination state. One can observe more warnings for the same flight path at the higher altitude due to the impact of altitude in the Safeguard algorithms. Additionally, the flight path with respect to the scoring system can be seen in Figure 43. The flight paths shown in Figures 40 and 43 utilize the same Safeguard log file, but Figure 43 has the inclusion of a TOI. A target of interest was placed on the loiter point, which is represented by the black star in Figure 43. This loiter point allowed in the for additional points to be collected, which can be seen in the difference of scores between the two flight tests. The cell with the black star collected 176 more points than the previous test in Figure 40. Additionally, the pre-flight set locations of the TOIs can be seen in Figure 44. Within this display, the color of the LED represents the level of confidence that the UAV has identified a TOI. If the LED within the scoring system display turns green, this means that the UAV accumulated over 90% of possible points for the cell with the specific target of interest. If the LED turns yellow, this means that the UAV accumulated between 50-89.9% of possible points for the cell. If the LED turns red, the UAV accumulated less than 10-49.9% of possible points for the cell. If the LED stays off, like the mannequin and UV emitter TOIs shown in Figure 44, then the UAV accumulated less than 10% of possible points for the cell, indicating that the TOI was not found. The water LED turned green, which means that the UAV found that TOI with a high degree of confidence.

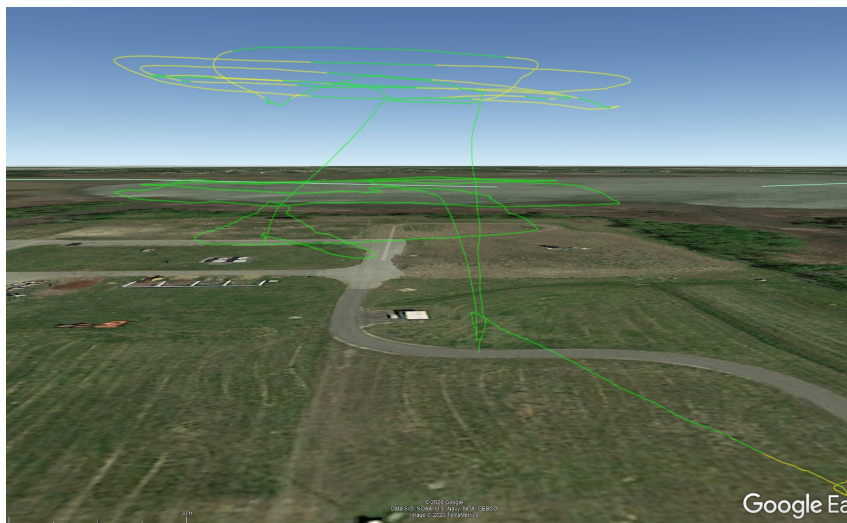

Figure 41. Safeguard target of interest 3D test side view.

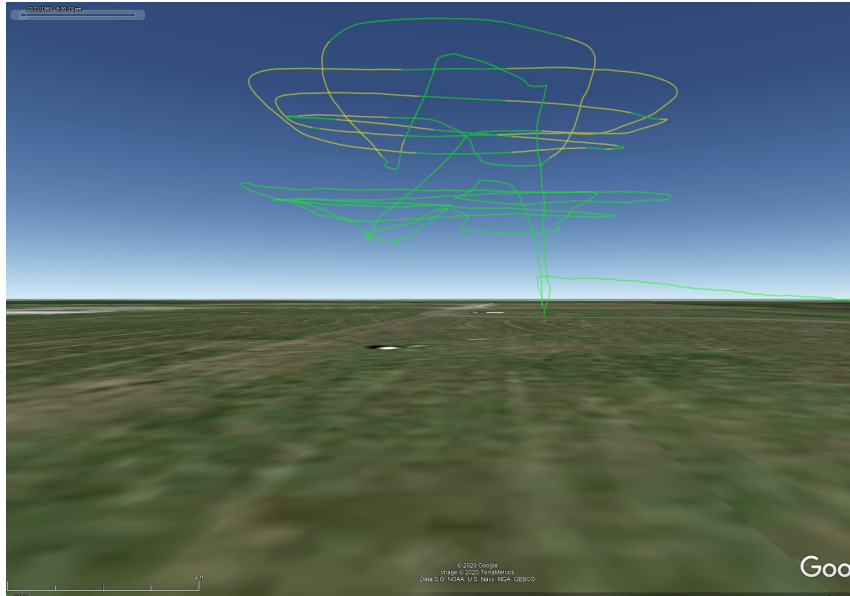

Figure 42. Safeguard target of interest 3D test ground view.

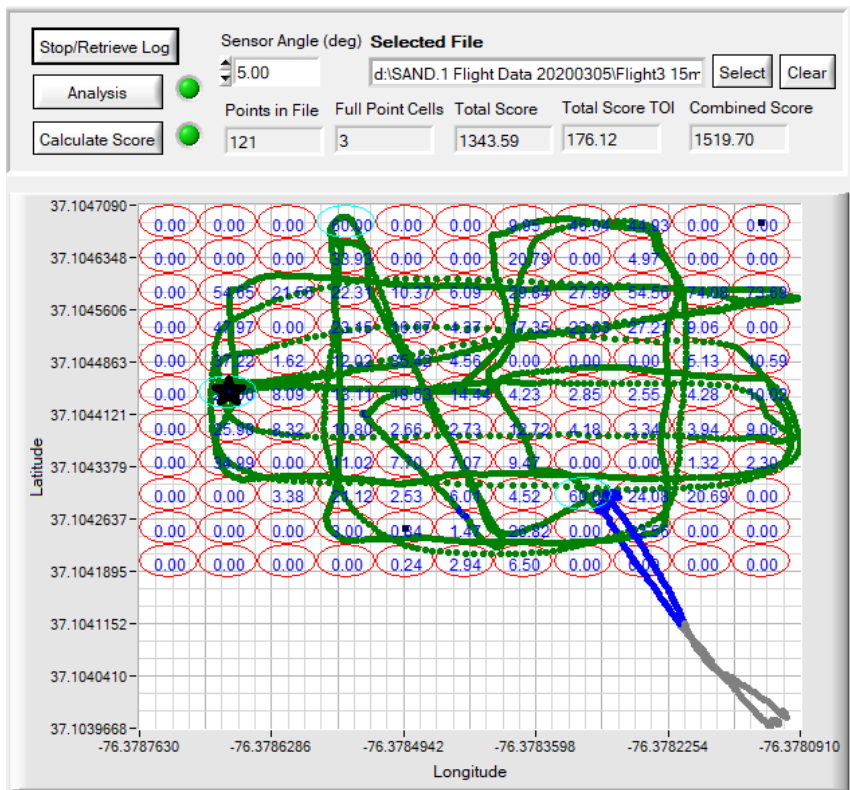

Figure 43. Sample scoring grid flight for the SAND competition with target of interest.

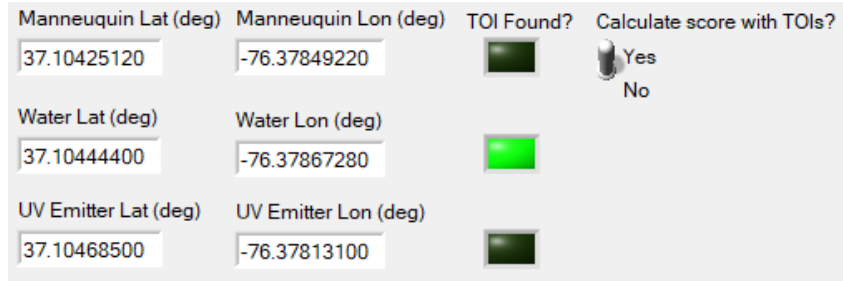

Figure 44. Target of interest LED display.

6.4.1 Limitations

Because the scoring system algorithm and tool was created purely with the SAND Challenge in mind and is meant to represent the post-disaster scenario, there are limitations. At the current time, the SAND team did not include all variable that may be of interest to a generic user, but the algorithm was developed to be robust and could be adapted to future applications and other variables, if necessary. The ground station interface has many applications worth considering, but currently is limited to Safeguard/SAND flight operations, utilizing the Safeguard log file and limited to the latitude and longitude specified for the SAND competition. Prior to flight, there are a number of required input parameters that need to be determined, such as altitude limitations and angle for field of view. The current scoring system expects to find these input parameters in the required configuration files.

7 Conclusions

The SAND flight testing confirmed that Safeguard could be configured and used to provide range containment for the proposed competition area of a 50 by 50 meter operational area and greater stay-in boundary for Darling Stadium. A reliable, effective, and simple set of electronics, the RFTIU, were developed and verified to demonstrate range containment within the Safeguard stay-in boundary. Full end-to-end testing of the Safeguard technology to ensure range containment was performed. The end-to-end testing with the two vehicles produced world-class post-termination data for multirotor UAVs, which will benefit Safeguard development as well as other UAS flight termination systems. While the actual competition was postponed, the testing and analysis performed herein yielded tremendous data towards establishing Safeguard's current efficacy and future modifications. A set of operational limits and configurable parameters were developed as a baseline for the SAND competition area. The proposed limits and settings provided margins for range containment while minimizing warnings if the vehicle remained inside the operational area. A robust scoring application was developed for the SAND competition and demonstrated using data from the flight tests in support for the quantitative portion of the score.

8 Recommendations

At this time, it is recommended that the Safeguard accelerations should be set to 2 in both the lateral and vertical directions with a landing buffer of 10 meters in order to satisfy stay-in constraints while minimizing the warnings while operating within the 50 by 50 meter operational zone. However, it is recommended that additional flight tests using the Langley Speedway stay-in geometry be conducted using the determined Safeguard configuration parameters in order to evaluate system performance in nominal and off-nominal cases. Additionally, flight testing for support of the scoring system and to validate the ability to capture a TOI is recommended. Finally, it is recommended that the full operations and simulation of the SAND competition be completed on the selected site prior to hosting a competition.

References

1. FAA, Concept of Operations v2.0,
https://www.faa.gov/uas/research_development/traffic_management.
2. NASA Technology Transfer Program: Reliable Geo-Limitation System for Unmanned Aircraft,
<https://technology.nasa.gov/patent/LAR-TOPS-244>.
3. Dill, E., Young, S., and Hayhurst, K., "SAFEGUARD: An Assured Safety Net Technology for UAS", 35th Digital Avionics Systems Conference, Sacramento, CA, 2016.
4. Dill, E., Hayhurst, K., Young, S., and Narkawicz, A., "UAS Autonomous Hazard Mitigation through Assured Compliance and Conformance Criteria", AIAA SciTech Forum, Kissimmee, FL, 2018.
5. Young, S., Dill, E., Hayhurst, K., and Gilabert, R., "Safeguard: Progress and Test Results for a Reliable Independent On-Board Safety Net for UAS", 36th Digital Avionics Systems Conference, St. Petersburg, FL, 2017.
6. Cunningham, K., Cox, D., Foster, J., Riddick, S., and Laughter, S., "AirSTAR Beyond Visual Range UAS Description and Preliminary Test Results", AIAA Scitech Forum, San Diego, CA, 2016.

REPORT DOCUMENTATION PAGE

*Form Approved
OMB No. 0704-0188*

The public reporting burden for this collection of information is estimated to average 1 hour per response, including the time for reviewing instructions, searching existing data sources, gathering and maintaining the data needed, and completing and reviewing the collection of information. Send comments regarding this burden estimate or any other aspect of this collection of information, including suggestions for reducing this burden, to Department of Defense, Washington Headquarters Services, Directorate for Information Operations and Reports (0704-0188), 1215 Jefferson Davis Highway, Suite 1204, Arlington, VA 22202-4302. Respondents should be aware that notwithstanding any other provision of law, no person shall be subject to any penalty for failing to comply with a collection of information if it does not display a currently valid OMB control number.

PLEASE DO NOT RETURN YOUR FORM TO THE ABOVE ADDRESS.

1. REPORT DATE (DD-MM-YYYY) 01-09-2020		2. REPORT TYPE Technical Memorandum		3. DATES COVERED (From - To)	
4. TITLE AND SUBTITLE Safeguard with Autonomous Navigation Demonstration Technical Closeout Report				5a. CONTRACT NUMBER	
				5b. GRANT NUMBER	
				5c. PROGRAM ELEMENT NUMBER	
6. AUTHOR(S) Steven Geuther, Louis Glaab, Thomas Johnson, Rafia Haq, and David Hare				5d. PROJECT NUMBER	
				5e. TASK NUMBER	
				5f. WORK UNIT NUMBER 432938.11.01.07.42.12	
7. PERFORMING ORGANIZATION NAME(S) AND ADDRESS(ES) NASA Langley Research Center Hampton, Virginia 23681-2199				8. PERFORMING ORGANIZATION REPORT NUMBER	
9. SPONSORING/MONITORING AGENCY NAME(S) AND ADDRESS(ES) National Aeronautics and Space Administration Washington, DC 20546-0001				10. SPONSOR/MONITOR'S ACRONYM(S) NASA	
				11. SPONSOR/MONITOR'S REPORT NUMBER(S) NASA/TM-2020-5005687	
12. DISTRIBUTION/AVAILABILITY STATEMENT Unclassified-Unlimited Subject Category 64 Availability: NASA STI Program (757) 864-9658					
13. SUPPLEMENTARY NOTES An electronic version can be found at http://ntrs.nasa.gov .					
14. ABSTRACT In preparations for the Safeguard with Autonomous Navigation Demonstration (SAND) competition, technical activities for validation of utilizing Safeguard as a independent flight termination system and a scoring system took place. The activities included assessment of the size of the flight area to allow adequate flight operations while maintaining margins for containment, development of an interface companion box to induce terminations, testing of Safeguard with intentional terminations of vehicles approaching a stay-in boundary, data analysis to understand the trajectory of multicopter in a freefall post-termination with wind and propeller spin down effects, and development of a scoring system using GPS data collected by Safeguard. Throughout this precursor of the SAND competition, a simple but reliable and easily verifiable companion system was developed to use the Safeguard signal to initiate a flight termination. In addition, multiple flight tests using multicopter unmanned aircraft system (UAS) with Safeguard equipped as both a payload and an active independent flight termination were carried out.					
15. SUBJECT TERMS Safeguard; UAS; Tech-Transfer; Trajectory					
16. SECURITY CLASSIFICATION OF:			17. LIMITATION OF ABSTRACT UU	18. NUMBER OF PAGES 50	19a. NAME OF RESPONSIBLE PERSON STI Information Desk (help@sti.nasa.gov)
a. REPORT U	b. ABSTRACT U	c. THIS PAGE U			19b. TELEPHONE NUMBER (Include area code) (757) 864-9658