



ARCSTONE: Calibration of Lunar Spectral Reflectance from Space

Cindy Young¹

**C. Lukashin¹ (PI), T. Jackson¹, T. Stone², G. Kopp³, R. Swanson⁴, N. Abraham⁵, E. Minda⁶
C. Buleri⁶, J. Carvo⁷, M. Cooney¹, H. Courrier⁴, W. Davis¹, A. Halterman⁶, M. Kehoe⁴, T. Nguyen¹
N. Ryan¹, P. Smith³, M. Stebbins⁴**

1 – NASA Langley Research Center, Hampton, VA

2 – USGS, Flagstaff, AZ

3 – LASP University of Colorado, Boulder, CO

4 – Resonon Inc., Bozeman, MT

5 – Goddard Space Flight Center, Greenbelt, MD

6 – Quartus Engineering, San Diego, CA

7 – Blue Canyon Technologies, Inc., Boulder, CO

Funded by ESTO: IIP-QRS-16-0018

SBIR programs: Phase-I & Phase-II

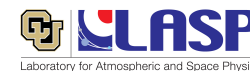

ARCSTONE: Team and Contributions

NASA LaRC

Mission concept & science
 Project management *
 Engineering coordination
 Instrument electronics
 Flight and ground software
 Mechanical, Thermal & Structural
 Environmental testing
 * SSAI: sub-contract management



Instrument concept
 Component characterization
 Radiometric calibration
 Error budget

NASA GSFC

Optical black coating



Instrument concept
 Instrument design
 Radiometric modeling
 Fabrication
 Assembly & alignment
 Functional testing



Lunar calibration approach (ROLO)



6U CubeSat Bus



Instrument Analysis (STOP, RV, TE)
 Input to instrument design
 Flexures design

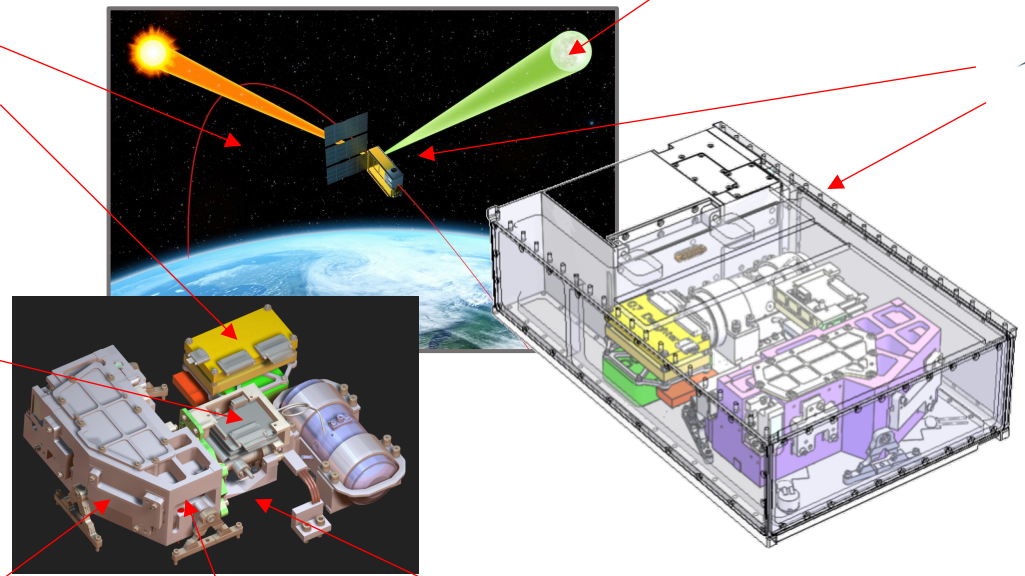

- ARCSTONE TEAM:**
- **NATIONWIDE COLLABORATION of EXPERTS !**
 - **Collaboration with NIST & UMBC:**
Ground and Airborne lunar measurements

Moon: Potentially Accurate Source for Calibration On-orbit

- Measurement accuracy related directly to its information content. Measurement accuracy is critical to entire EOS !
- Current EOS cannot handle data gaps. Need overlapping observations: CERES, MODIS/VIIRS, Landsats, PACE/SeaWIFS, etc.

Calibration reference: Lunar Spectral Irradiance (entire disk)



Reflectance of Lunar surface stable to $< 10^{-8}$ / year

- Accuracy of current Lunar Model (ROLO): 5 – 10%
- SeaWiFS gain stability: 0.13% (k=1) over 12 years

On-Orbit Calibration Need:

Absolute accurate spectral irradiance for all lunar phase and libration states.

Expected Impacts:

- Quality of data products
- Long-term consistency
- Handling data gaps
- Reduces instrument size, mass, power
- Reduce complexity
- Accurate CubeSat sensors

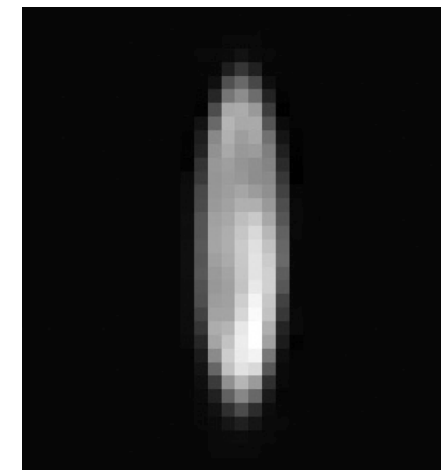

Lunar image by SeaWIFS



Applications of the Lunar Calibration Approach (satellite operators worldwide !)

Team	Satellite	Sensor	G/L	Dates	Number of obs	Phase angle range (°)
CMA	FY-3C	MERSI	LEO	2013-2014	9	[43,57]
CMA	FY-2D	VISSR	GEO	2007-2014		
CMA	FY-2E	VISSR	GEO	2010-2014		
CMA	FY-2F	VISSR	GEO	2012-2014		
JMA	MTSAT-2	IMAGER	GEO	2010-2013	62	[-138,147]
JMA	GMS5	VISSR	GEO	1995-2003	50	[-94,96]
JMA	Himawari-8	AHI	GEO	2014-	-	
EUMETSAT	MSG1	SEVIRI	GEO	2003-2014	380/43	[-150,152]
EUMETSAT	MSG2	SEVIRI	GEO	2006-2014	312/54	[-147,150]
EUMETSAT	MSG3	SEVIRI	GEO	2013-2014	45/7	[-144,143]
EUMETSAT	MET7	MVIRI	GEO	1998-2014	128	[-147,144]
CNES	Pleiades-1A	PHR	LEO	2012	10	[+/-40]
CNES	Pleiades-1B	PHR	LEO	2013-2014	10	[+/-40]
NASA-MODIS	Terra	MODIS	LEO	2000-2014	136	[54,56]
NASA-MODIS	Aqua	MODIS	LEO	2002-2014	117	[-54,-56]
NASA-VIIRS	NPP	VIIRS	LEO	2012-2014	20	[50,52]
NASA-OBPG	SeaStar	SeaWiFS	LEO	1997-2010	204	(<10, [27-66])
NASA/USGS	Landsat-8	OLI	LEO	2013-2014	3	[-7]
NASA	OCO-2	OCO	LEO	2014		
NOAA-STAR	NPP	VIIRS	LEO	2011-2014	19	[-52,-50]
NOAA	GOES-10	IMAGER	GEO	1998-2006	33	[-66, 81]
NOAA	GOES-11	IMAGER	GEO	2006-2007	10	[-62, 57]
NOAA	GOES-12	IMAGER	GEO	2003-2010	49	[-83, 66]
NOAA	GOES-13	IMAGER	GEO	2006	11	
NOAA	GOES-15	IMAGER	GEO	2012-2013	28	[-52, 69]
VITO	Proba-V	VGT-P	LEO	2013-2014	25	[-7]
KMA	COMS	MI	GEO	2010-2014	60	
AIST	Terra	ASTER	LEO	1999-2014	1	-27.7
ISRO	OceanSat2	OCM-2	LEO	2009-2014	2	
ISRO	INSAT-3D	IMAGER	GEO	2013-2014	2	



From GSICS Lunar Calibration Workshop, December 2014, EUMETSAT.

- Instruments with lunar calibration capabilities participating in the GSICS GIRO program
- *List includes sensors with lunar observations submitted to the database at EUMETSAT as of December 2014.*
- *Next GSICS Lunar Calibration Workshop: November 2020, virtual (?)*

ARCSTONE Full Spectral Range (FSR): Objectives

OBJECTIVES:

- To enable on-orbit high-accuracy absolute calibration for the past, current, and future reflected solar sensors in LEO and GEO* by providing lunar spectral irradiance as function of satellite viewing geometry and specified wavelength.
- To design, build, calibrate and validate a prototype instrument, demonstrate *form-fit-function for a 6U observatory with compliance in size, mass, power, and thermal performance.*

* Planetary instruments: OSIRIS Rex Camera suite [Golish et al., 2020]

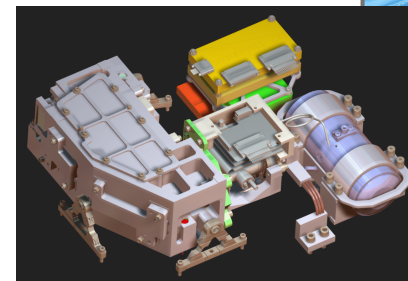
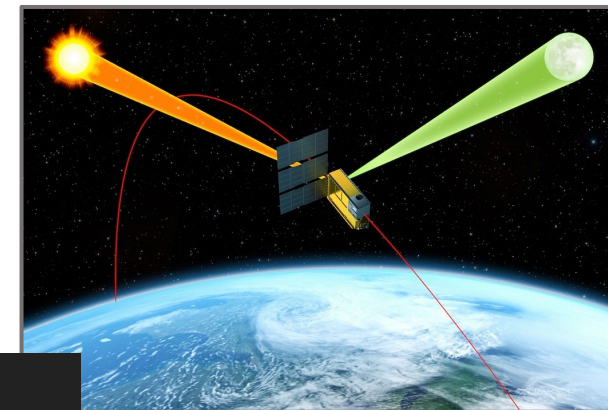

ARCSTONE FSR Concept: Accurate measurements of Lunar Irradiance from Space with an Instrument flying on 6U CubeSat (courtesy BCT) in LEO.

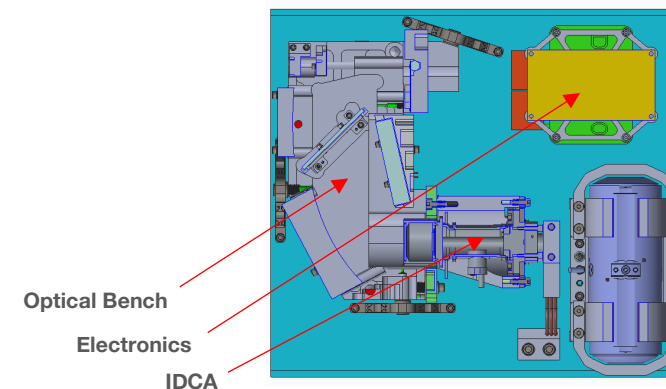

Progress of ARCSTONE FSR instrument Design

TRL_{current} = 4 TRL_{out} = 5

ARCSTONE FSR Mission Concept

Concept of Operations and Data Products:

- Data to collect: Lunar spectral irradiance every 12 hours, 10 minutes
- Data to collect: Solar spectral irradiance for calibration (daily)
- Combined uncertainty < 0.5% (k=1)
- Spectrometer with single-pixel field-of-view about 0.7° (no scanning !)
- Sun synchronous orbit at 500 – 600 km altitude
- Spectral range from 350 nm to 2300 nm, spectral sampling at 4 nm

1 year: Improvement of current Lunar Calibration Model (factor of 2 – 4);

3+ years: New Lunar Irradiance Model, improved accuracy level (factor of 10).

Key Technologies to Enable the Concept:

- Approach to orbital calibration via referencing Sun (TSIS measurements):
 Demonstration of lunar and solar measurements with *the same optical path using integration time to reduce solar signal -- Major Innovation !*
- Pointing ability of spacecraft now permits obtaining required measurements *with instrument integrated into spacecraft.*

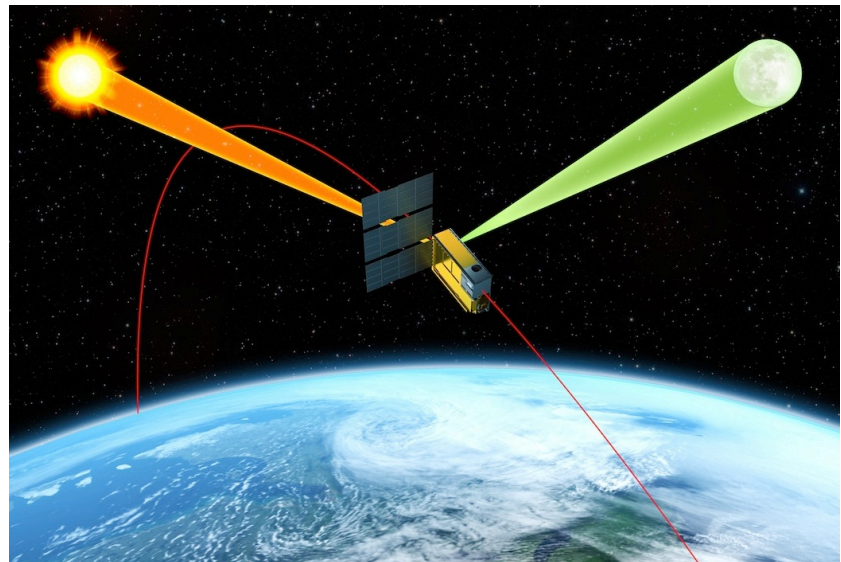

6U CubeSat Spacecraft Bus:
 courtesy of Blue Canyon Technologies (BCT)

BCT 6U XB6 Spacecraft pointing:
 Accuracy 0.002° (1-sigma) in 3 axis
 Stability 1 arc-sec over 1 sec



ARCSTONE: Science Traceability Matrix

ARCSTONE Goals	Earth Science Impacts	Mission Requirements	Measurement Requirements	Instrument Requirements	Data Products	
Enable record accuracy for on-orbit SI-traceable calibration for reflected solar Instruments in LEO and GEO, and Planetary	Climate Benchmark and Direct Inter-Calibration	Establish calibration standard on-orbit: Lunar spectral reflectance with accuracy < 0.5% Sufficient sampling of lunar librations Lunar spectral irradiance model with uncertainty < 0.7% (k=1) On-orbit calibration against TSIS/SIM Solar Spectral Irradiance (SSI) 0.2% reference accuracy Duration: 3 years	Calibration to Solar spectral irradiance	Single FOV spectrometers Pointing accuracy < 0.05° (with bus) Size: 6U CubeSat payload Payload mass < 6 kg Payload power < 40 W Ability to reduce solar signal: factor of a ~ 10 ⁵	Level-1: Calibrated high-accuracy lunar spectral reflectance	
	LEO/GEO Imagers (e.g. VIIRS, ABI): Clouds, Aerosols, Land, Weather		Lunar spectral irradiance with uncertainty < 0.5%			SNR < 1% in UV/VIS SNR < 2% in SWIR
	Atm. Chemistry (e.g. GOME, TEMPO) Trace gases		Wavelength range: 350 nm – 2300 nm			
	Ocean Color Record: PACE & SeaWIFS		Spectral sampling: < 4 nm			
	Sustained Land Imaging: Landsats		Lunar measurement frequency: 12 hours		Solar measurement frequency: daily	Level-2: New empirical model for high-accuracy lunar spectral irradiance
	SBG Calibration: VSWIR Instrument					
	In-Situ: Aerosol OD Nighttime Obs.					



ARCSTONE Mission: Key Performance Parameters

Key Parameters	Threshold Value	Goal Value
Accuracy (reflectance)	1.0% (k=1)	0.5% (k=1)
Stability	< 0.15% (k=1) per decade	< 0.1% (k=1) per decade
Orbit	Sun-synch orbit	Sun-synch orbit
Time on-Orbit	1 year	3 years
Frequency of sampling	24 hours	12 hours
Instrument pointing	< 0.2° combined	< 0.1° combined
Spectral Range	380 nm – 900 nm	350 nm – 2300 nm
Spectral Sampling	8 nm	4 nm

ARCSTONE MISSION CONOPS:

1. Lunar spectral irradiance observations:

- Every 12 hours
- Close to polar locations
- Multiple measurements within 5– 10 minutes to improve SNR

2. Solar Spectral Irradiance observations (solar calibration):

- Multiple measurements to get required SNR
- This is radiometric calibration to the TSIS reference

3. Dark images:

- Multiple measurements with closed shutter
- Before every lunar and solar observations

4. Dark field (to calibrate out shutter temp):

- Multiple measurements of dark space

5. Field-of-view sensitivity characterization:

- Calibration of instruments alignment

6. Spectral calibration:

- On-board passive spectral calibration

7. Spacecraft pointing calibration and other checks:

- Defined by the BCT for calibration of spacecraft functions

8. Stand by mode:

- Mode between observations

9. Data Downlink Mode

10. On-board data processing mode (if required)

11. Safe Mode (if required)

* 6U CubeSat accommodation Study in progress

* Requirements are captures in a Mission Requirements Document

** Threshold Values considered as success criteria

Reference for radiometric requirements (ROLO, T. Stone):

Lunar Phase Angle = 75°;

Irradiance = 0.6 (micro W / m² nm)

Wavelength = 500 nm

Lunar Observation Sequence

- Every 12 hours
- Close to polar locations in-orbit
- Predicted with ground Science Prediction System (SPS) weekly

Point close to the Moon (TBD), time to settle

Dark field (to calibrate instrument thermal background):

- Multiple measurements of dark space with shutter closed and open

Point at the center of Moon disk and track, time to settle

Dark images:

- Multiple measurements (e.g. 10) with closed shutter

Lunar spectral irradiance observations:

- 16 seconds integration time for a single measurement
- Multiple measurements (e.g. 10) within 5 minutes to get required SNR

ARCSTONE requires accurate pointing/tracking !

BCT XB6 pointing *uncertainties* [public information]:

- +/- 0.002° pointing accuracy (1 sigma), 3 axes, 2 trackers
- Tracking stability 1 arcsecond per second, 3 axes, 2 trackers

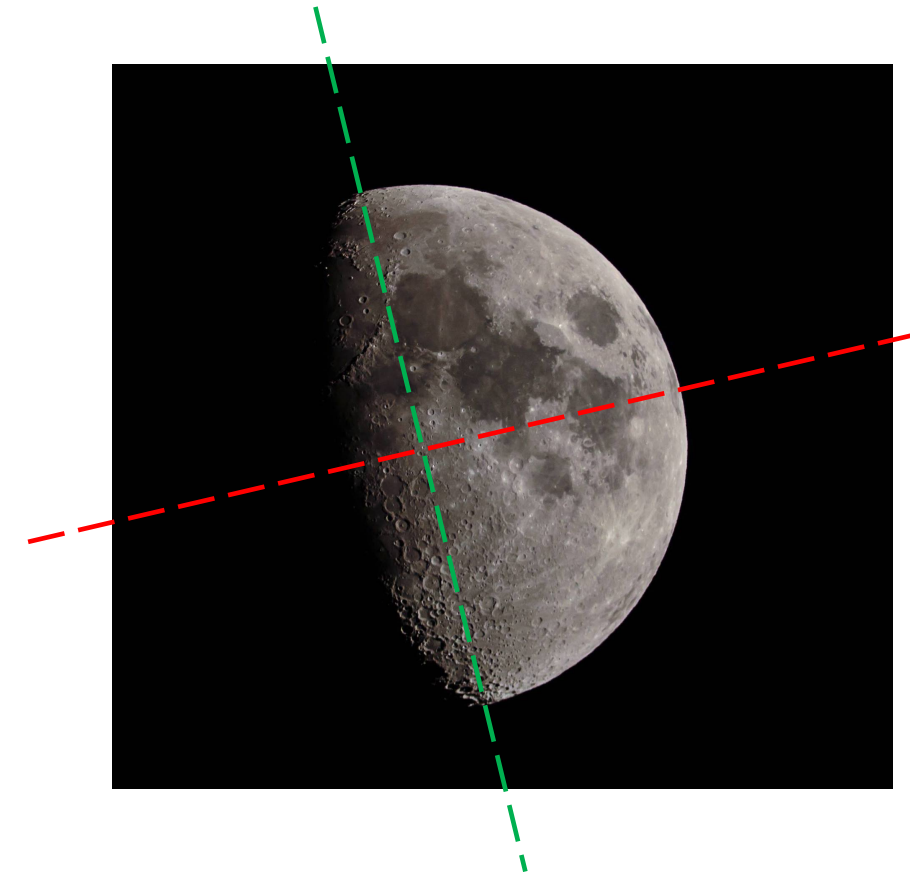

Two instrument alignment modes:

- Orthogonal to A-M-S plane
- **Parallel to A-M-S plane**

* A-M-S: ARCSTONE-Moon-Sun

ARCSTONE FSR: Instrument in Fabrication

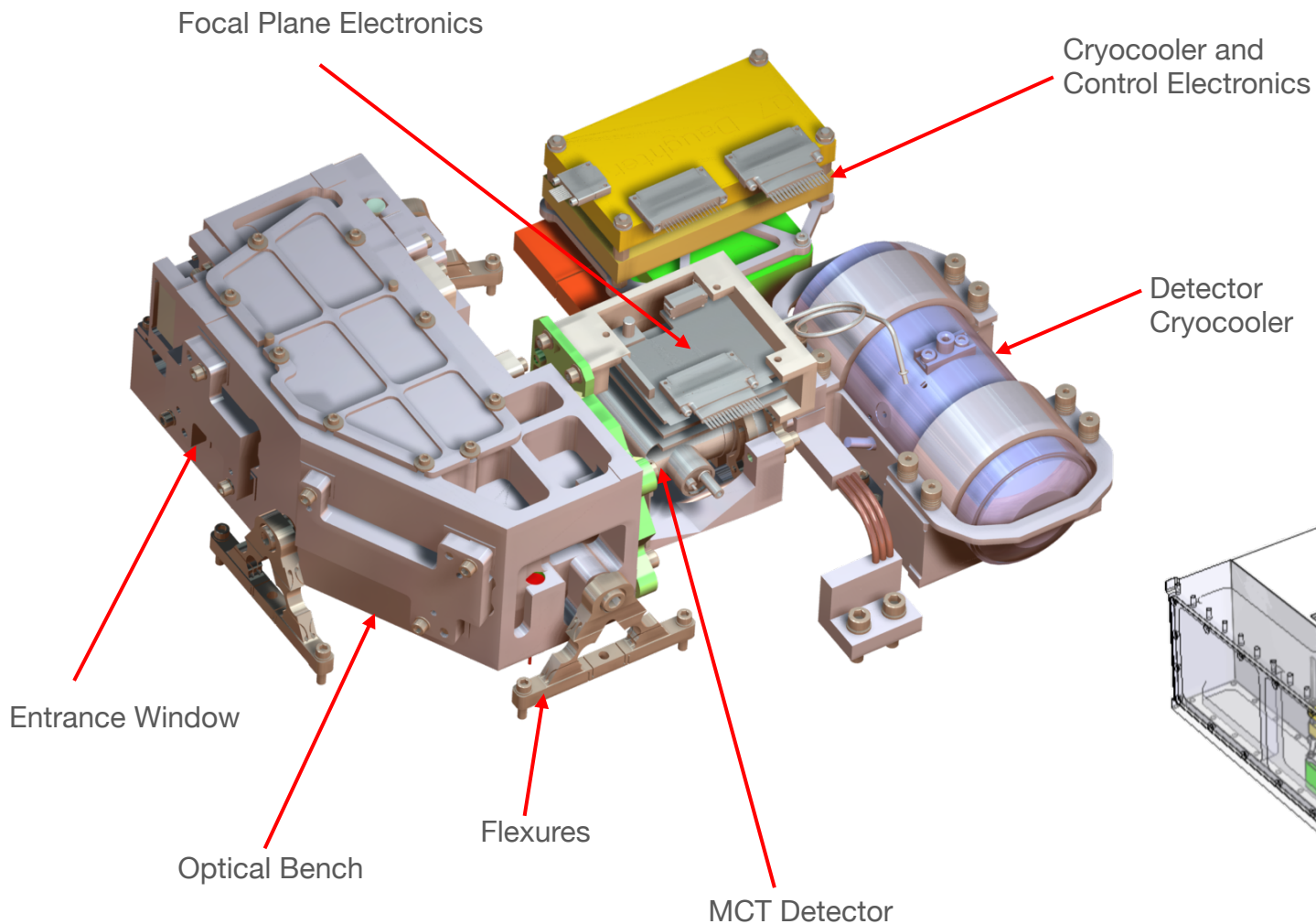

Volume:
Fits within up-to-date spacecraft bus CAD from BCT with at least 0.5mm clearance from all payload walls/features

Mass:
4.13 kg (6 kg payload allowable)

Power (all worst cases):
Science Mode: 23.83 W (118 W peak allowable)
TX Mode: 34.07 W
Stand By Mode: 15.5 W

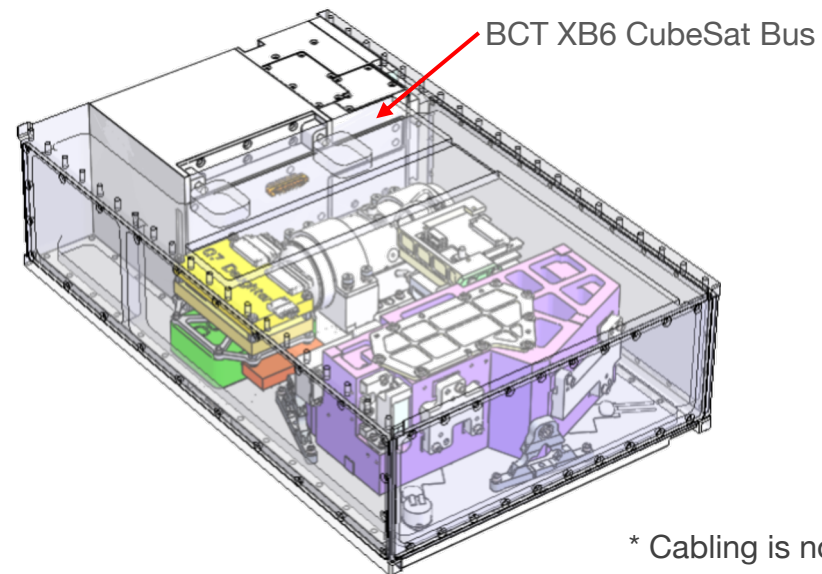

ARCSTONE FSR Instrument Analysis

Output Set: THERMAL SOAK TO -30C / -133.15C (minus Alignment Config) [micron]
Elemental Contour: Total Translation

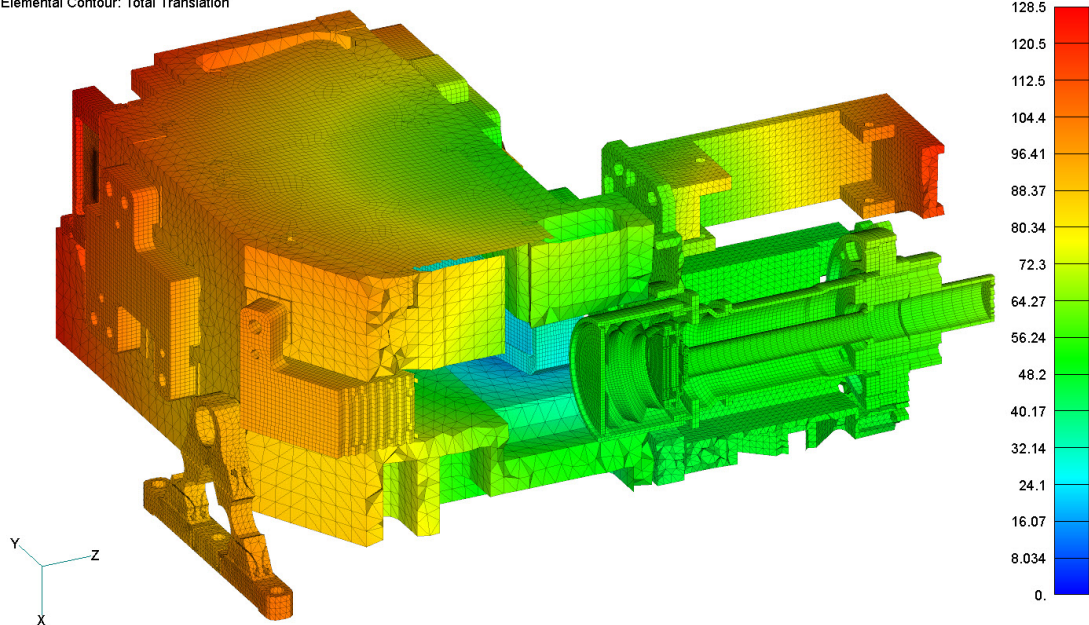

Optic bench displacements [microns] at -30°C .
Cutaway shows interior of camera dewar/cold finger.

Performed Analysis: STOP, Thermoelastic, Random Vibe

Optic bench random vibration analysis.

Output Set: 3sigma RMS Von Mises Stress (MPa)
Nodal Contour: Plate Top VonMises Stress

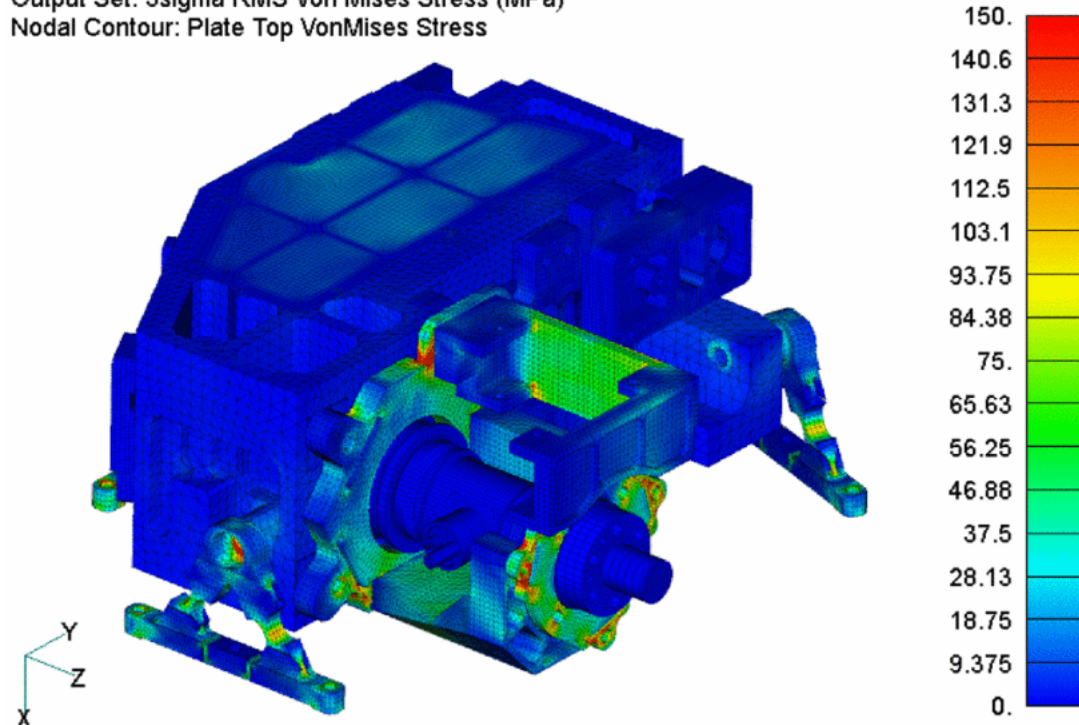

ARCSTONE: SWIR IDCA Characterization

- **Sensor is uniform**
 - 745 hot/dead pixels
 - Only 2 pixels with no normal surrounding pixels
- **Vertical banding apparent in both dark and light images**
 - Eliminated through dark subtraction

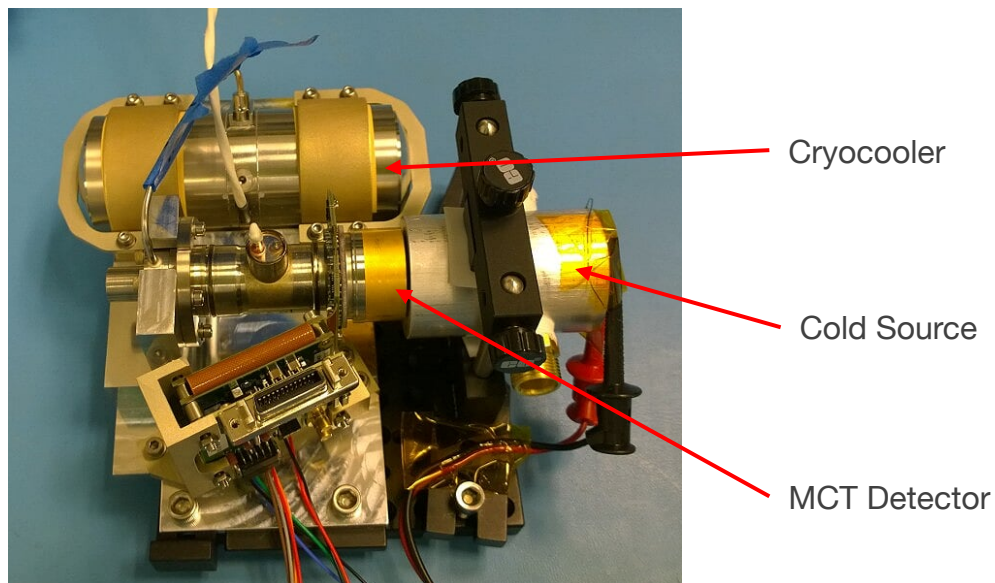

Major Credits:

- IDCA selection/acceptance: Mike Cooney (NASA LaRC)
- Mechanical design: Trevor Jackson (NASA LaRC)
- IDCA characterization: Paul Smith (LASP, CU)

Integration time from 10^{-4} to 3.3 seconds !

SWIR IDCA Characterization Conclusions:

- (1) SWIR IDCA *usable at 0.3% - 0.4% uncertainty level:*
 - *Primary contributor to uncertainty is variation in the offset value between its measurements (repeatability over a few days).*
 - *Offset value variation is a systematic uncertainty that cannot be mitigated through increased averaging, but may be lower during real data collecting operations, e.g. measuring offset before every lunar observation.*
- (2) Camera linearity: *better than expected at 0.1% !*
- (3) Initial Vibe and TVAC tests: *positive results !*

FSR IDCA is essentially the same as SWIR IDCA (except for detector, OB filter, and integration time extended to 16 seconds)

ARCSTONE IIP: Status and Next Steps

Status:

- UV-VNIR EDU instrument is complete and radiometrically calibrated
- Fabrication complete for SWIR EDU instrument (assembly is on hold)
- Breadboard VIS instrument ready for field tests
- Design and STOP analysis completed for FSR EDU instrument
- 6U CubeSat accommodation study completed
- Fabrication of FSR instrument is in progress

Next Steps:

- Complete 6U CubeSat/Payload thermal study (September 2020)
- Complete fabrication of FSR instrument (October 2020)
- Characterize FSR IDCA (January 2021)
- Assemble FSR instrument (February 2021)
- Calibrate FSR instrument (May 2021)
- Field-test FSR instrument with Sun and Moon (TRL5, June 2021)



Testing ARCSTONE field equipment at NASA LaRC



ARCSTONE: Calibration of Lunar Spectral Reflectance from Space

Recent Publications:

Swanson, R., C. Lukashin, M. Kehoe, M. Stebbins, H. Courier, T. Jackson, M. Cooney, G. Kopp, P. Smith, C. Buleri, T. Stone, “The ARCSTONE Project to Calibrate Lunar Reflectance,” *IEEE Aerospace Proceedings*, 2020

Available online: <https://ieeexplore.ieee.org/abstract/document/9172629>

Stone, T.C., H. Kieffer, C. Lukashin, K. Turpie, “The Moon as a Climate-Quality Radiometric Calibration Reference,” *Remote Sens.*, 12, 1837, 2020

Available online at <https://www.mdpi.com/2072-4292/12/11/1837>



ARCSTONE: Calibration of Lunar Spectral Reflectance from Space

<http://arcstone.larc.nasa.gov>

The screenshot shows the ARCSTONE website interface. At the top, there is a navigation menu with links for NASA, LARC, CLARREO, NAIADS, LASERTECH, ARCSTONE, GEO, SCIAMACHY, SOFTWARE, News, Weather, Banking, Mail, KAYAK, ASTRO, and Popular. Below the menu are the NASA and ARCSTONE logos, and a navigation bar with links for Home, About, Team, and Contact. The main content area features a large banner image of the ARCSTONE logo over a stylized Earth and Moon. Below the banner is an article titled "Achieving Instrument High Accuracy In-Orbit". The article text discusses the challenges of remote sensing from space and the ARCSTONE mission concept. To the right of the text is an illustration of the ARCSTONE satellite in orbit, with a caption explaining its rotation to view the Sun and Moon. Below the article is a "LEARN MORE" button. At the bottom of the article, there is a quote from Hugh Kieffer and Tom Stone about the Moon's availability for calibration.

Achieving Instrument High Accuracy In-Orbit

One of the most challenging tasks in remote sensing from space is achieving required instrument calibration accuracy on-orbit. The Moon is considered to be an excellent exoatmospheric calibration source. However, the current accuracy of the Moon as an absolute reference is limited to 5 - 10%, and this level of accuracy is inadequate to meet the challenging objective of Earth Science observations. ARCSTONE is a mission concept that provides a solution to this challenge. An orbiting spectrometer flying on a small satellite in low Earth orbit will provide lunar spectral reflectance with accuracy sufficient to establish an SI-traceable absolute lunar calibration standard for past, current, and future Earth weather and climate sensors.

[LEARN MORE](#)

The ARCSTONE observatory is shown in low Earth orbit with the spectrometer viewing the Sun and Moon. The spacecraft rotates in order to view the Moon or the Sun.

“The Moon is available to all Earth-orbiting spacecraft at least once per month, and can be used to tie together the sensor radiance scales of all instruments participating in lunar calibration without requiring near-simultaneous observations.”

— HUGH KIEFFER & TOM STONE

THANK YOU !