

National Aeronautics and Space Administration



Battery Hibernation for Surviving the Lunar Night

Presented at the 2021 Space Power Workshop
April 19, 2021

Richard Oeftering, William Bennett, Frederick Vankeuls, Nicholas Uguccini

NASA Glenn Research Center
Cleveland, Ohio 44135



Battery Hibernation for Surviving the Lunar Night

Battery Hibernation is an approach to dramatically extend capabilities and duration of low-cost robotic lunar missions by exploiting the common 18650 Li-ion Cell's ability to tolerate and recover from extreme cold of the lunar night.

- Surveyor Experience
- Environment and Mission Constraints.
- Corroborating Publications on Cell Hibernation
- NASA Glenn Research Center Cell Testing
- Power Hibernation and Dawn Operations
- Hibernation Battery Development

Surveyor Experience: Surviving the Lunar Night



Common Misconception: “Spacecraft batteries cannot take extreme lunar night temperatures and will die”. ***This is Not True***

- *New evidence shows that common lithium-ion cells can survive.*
- *Successful Hibernation depends a power system’s ability to safely restore itself at lunar dawn*

Surveyor Missions Experience (1966-1968)

- Surveyor was not designed for Night Survival
- RTG technology still under development
- Multiple Surveyors did indeed survive the night
 - Surveyor 1 operated fully/partially for 6 lunar cycles
 - Each mission responded differently

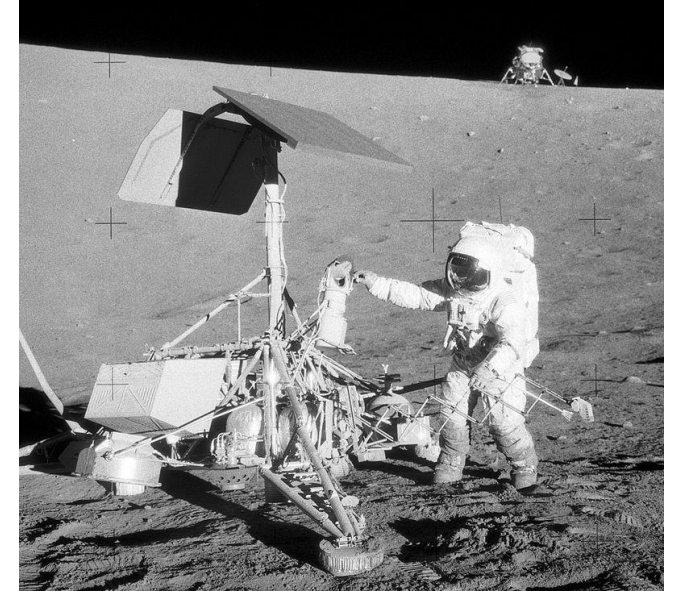

NASA Photo

LRO DIVINER: Lunar Day/Night Temperature Range by Latitude



Thermal model calculations of monthly and annual lunar surface temperature variations at various latitudes.

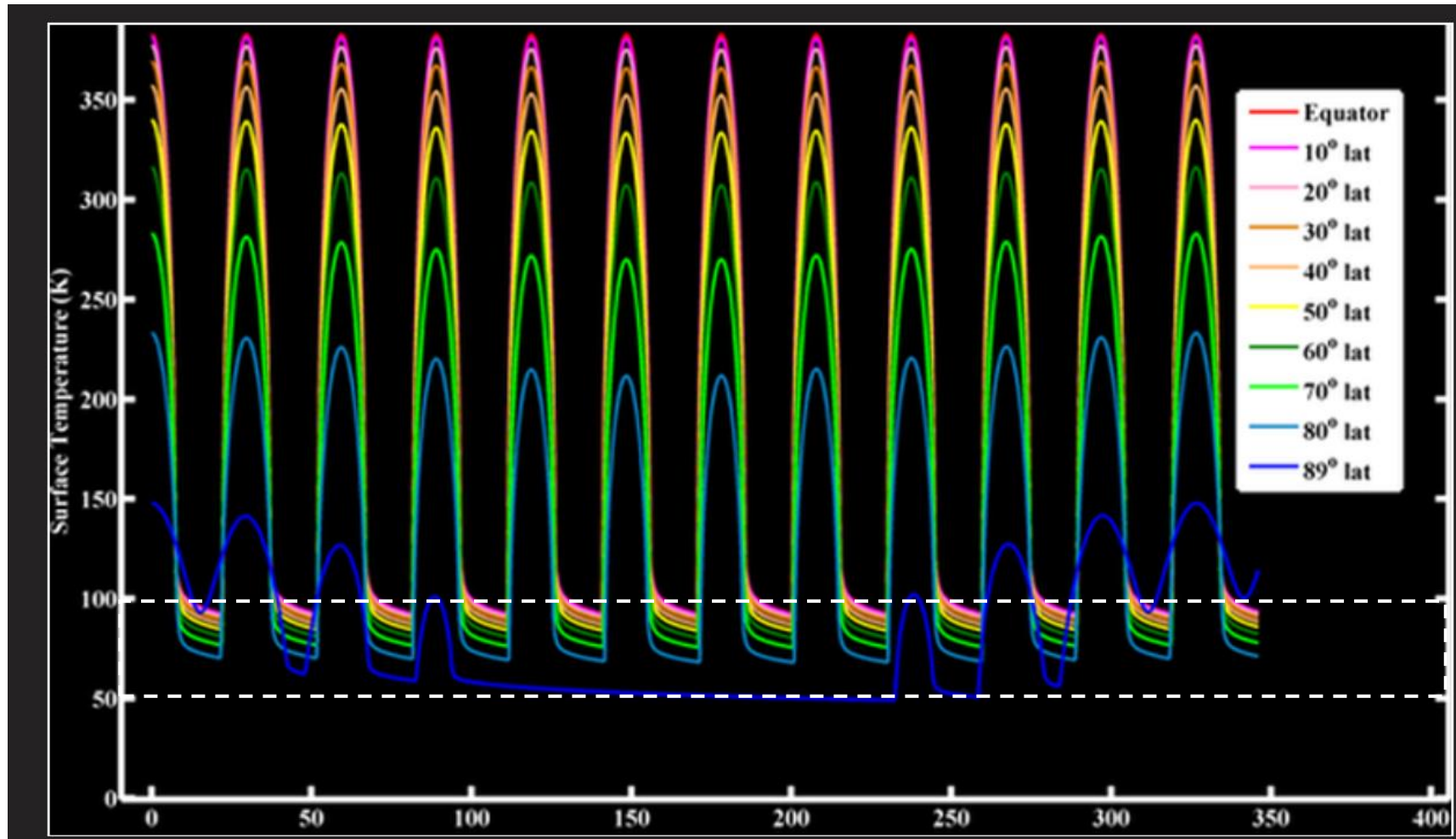

**Lunar Night
Temperatures are
extremely cold
everywhere**

Permissions per Dr. N Petro/NASA GSFC and Dr. D Paige/UCLA

Environment and Mission Constraints



Extreme Thermal Environment

- Day temperatures span from 100K to near 400K based on Latitude
- Night temperatures fall within a 50-100K range regardless of latitude.
- Non-Polar latitudes night durations ~354 hours
- Polar Regions have very low sun angle varying sun/shade cadence and durations
 - Site elevation combined with near/far topographical features casting shadows
 - Seasonal Variations (sun drops below horizon in lunar winter)

Low-Cost Mission Constraints

- Commercial Lunar Payload Services (CLPS) landers are limited to one lunation
 - (29 ½ day lunar cycle).
- For Non-Polar missions, hibernation is the most viable option

Li-ion Low Temperature Survival Corroborating Evidence



Indian Space Research Organization (ISRO) published work on Hibernation

- 2018 ISRO investigated 18650 Li-ion cell passive lunar night survivability.
 - Evaluated 3 manufacturers of 18650 Li-ion cells.
 - Subjected them to 14 day lunar night at -160°C (in vacuum)
 - Cells recovered charge capacity with no apparent damage or degradation
- ISRO published a power architecture concept for Hibernation
- Its not clear if hibernation capability was on-board Chandrayaan-2 lander
 - *(It is clear that they were thinking about it.)*
- Growing interest in “Flash-Freezing” of Li-ion batteries for transportation safety

Cell Hibernation Investigation at NASA Glenn

Tested with LN₂ at 1 Atmosphere



18650 Li-ion Preliminary Test Setup

- Suspended in LN₂ vapor, (not submerged)
- Cells were insulated to limit thermal shock
- Warmed in dry N₂ to limit frost/condensation

Preliminary Results

- At T < 200K (-70°C) electrolyte freezes
- Cell voltage drops to zero
- Cold soak to 80K (-193°C) overnight
- All cells recovered above 200K
- 2 of 5 cells recovered but safety device tripped
- 3 of 5 recovered without problems

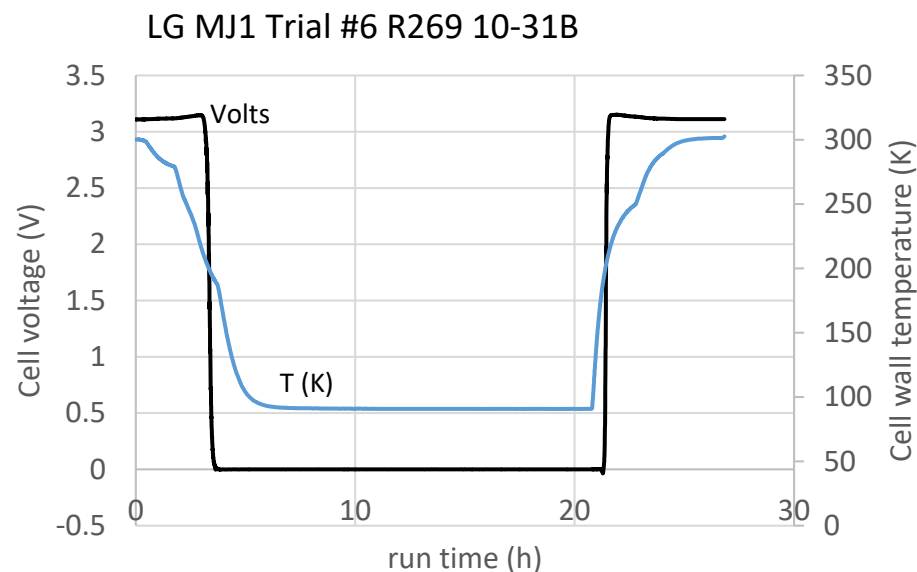

Figures Courtesy of W. Bennett, NASA Glenn

Cell Hibernation Investigation at NASA Glenn

Tested with LN₂ at 1 Atmosphere



2 of 5 Cells Safety Device Trips

- First cell Current Interruption Device tripped
 - (CID contact opened)
- Second cell burst disc vented
 - (CID contact opened and vented)

Root cause of trips is not fully understood

- Cause of internal overpressure is unclear
- Normally, gas pressure is due to electrode and electrolyte decomposition
- Probe of the “Jelly Roll” indicated normal voltage
- Possible seal leak trapping LN₂
- Safety Device may be sensitive to combined pressure reversal and thermal cycle

NORMAL Cell Cross Section

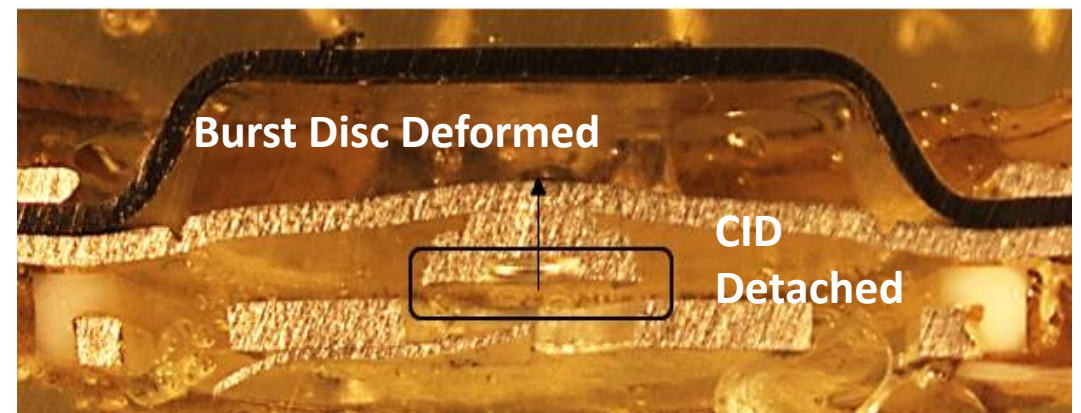
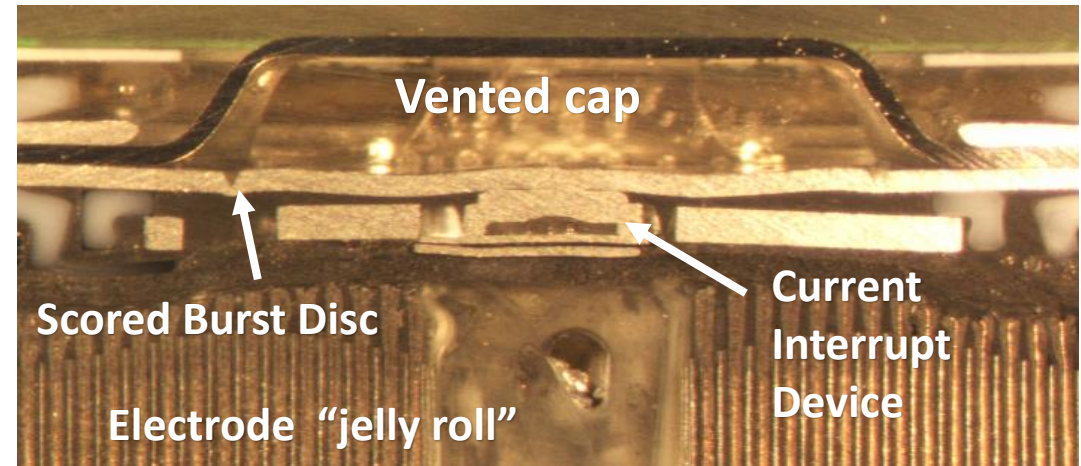

Figures Courtesy of W. Bennett, NASA Glenn

Cell Hibernation Investigation at NASA Glenn

Tested with Cryocooler in Vacuum



Revised Test Setup

- Improved representation of lunar environment
 - Vacuum chamber pressure at ~ 70 mtorr
 - Cryocooler chilled and held near 100K.
 - Eliminated pressure reversal risk
 - Eliminated leakage of condensed gas
- Voltage dropped below 200K
- Voltage recovers when warmed above 200K
- 4 of 4 cell trials in vacuum were successful
 - *No CID Trips or Disc Ruptures*

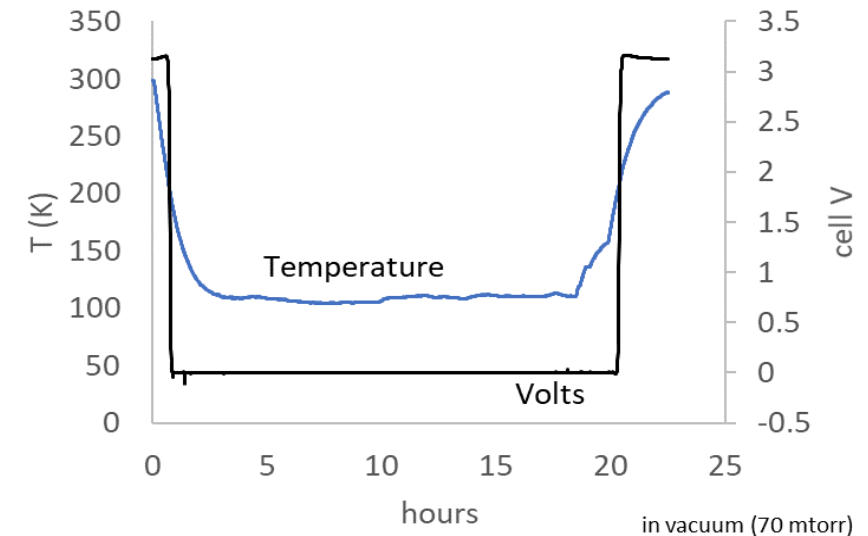
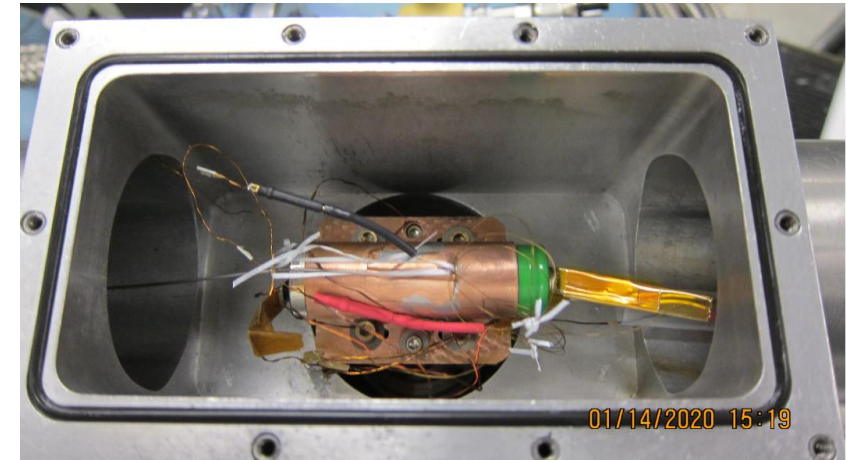

Photos courtesy of W. Bennett NASA Glenn

Power Hibernation and Dawn Operations



Lunar Dusk:

Point Arrays toward Dawn, Shut-Down Loads, Isolate Battery, Wait for Dawn

Lunar Dawn: (first illumination, coldest temperature)

- Solar Array output triggers a “**Dawn Mode**” within the **Main Bus Controller (MBC)**
- MBC is composed of electronics designed to operate in extreme cold temperature
- MBC in Dawn Mode operates on Solar Array power alone (*Battery still Isolated*)
- MBC manages thermal conditioning (Pre-Heaters) for battery and avionics
- Battery Management System (powered by MBC, also operates in extreme cold)
 - Monitor battery temperatures and voltages during Dawn Pre-heat
 - On reaching safe temperatures BMS performs battery pre-charge.
 - Pre-charge continues until battery and main bus voltages match.
- MBC Closes Isolation Relay: Reconnects Battery to Main Bus- **Dawn Mode Complete!**
 - MBC clears “Power Inhibits” allowing system to boots-up as normal

MBC & Battery Management Functions

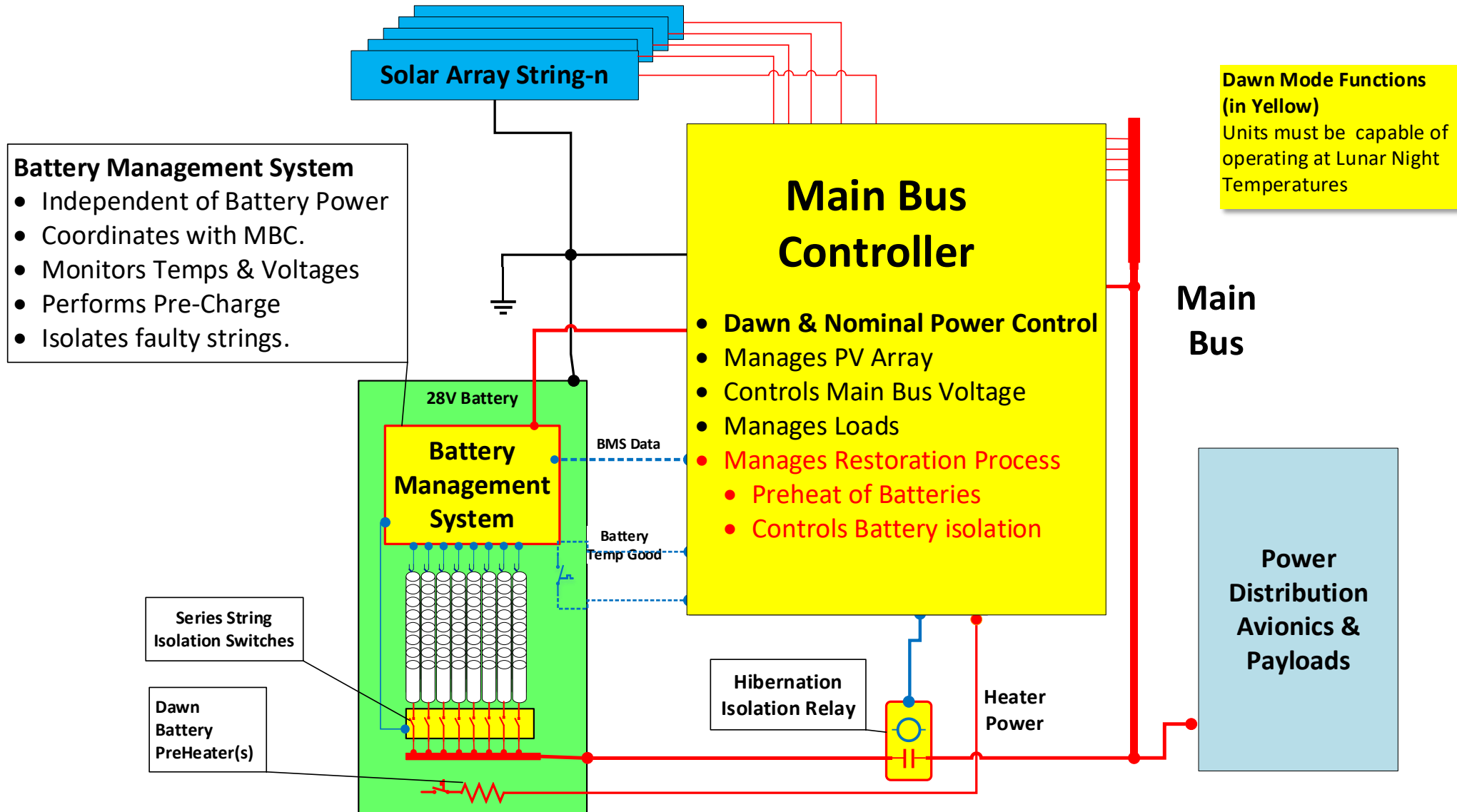

Hibernation Battery Development



Li-Ion Cell work

- NASA preliminary testing was limited to mostly one source
- ISRO tested 3 manufacturers (were not identified)
- **Future Hibernation Tests**
 - Evaluate a wider range of cell manufacturers
 - Testing of cells certified for human space flight
 - Strategic procurements of 40,000-60,000 cell lots
 - Controlled supply “Chain of Custody”
 - Establish Statistical Confidence
- Evaluate alternate cell formats (20700, 21700)
- Establish safe cell hibernation cycle guidelines
- Investigate possible pre-thaw Fault Detection (*cells are safest when frozen*)
- Applicable to lunar robotics and lunar systems supporting human missions

Hibernation Battery Development



Hibernation Battery Engineering

- Develop a hibernating battery design and package concept
 - Battery Thermal Model
 - Pre-heating management (temperature uniformity, uniform cell output)
- Battery Management System includes:
 - Cell Monitoring
 - Pre-Charge Control,
 - Fault Detection & Faulted String Isolation
- Battery Life Testing to demonstrate multiple lunar cycles.

Battery Hibernation Summary



Hibernation Enables Low-Cost Missions Achieve Multi-Lunation Cycles

- 18650 Li-ion cells demonstrated a night survival capability.
- “Passive Hibernation” minimizes changes to existing hardware.
- Reduced Dependency on scarce radioisotope heat and power sources.
- Robotics & Vehicles operate independent pre-established infrastructure
- Hibernation also provides survival & recovery options in contingency situations.
- **Ultimately:** *Hibernation and supporting technologies will lead to a more robust and extreme environment tolerant robotic systems*

References



- NASA TM 33-432 *Surveyor Batteries: Final Engineering Report*, A.J. Moses, W.M. Hetherton, D. Weinberger, Hughes Aircraft Co., A.A. Uchiyama, R.S. Bogner, W.L. Long, Jet Propulsion Laboratory. Feb 1970.
- *Surveyor Final Engineering Report, Vol II System Design*, SSD 88027, Hughes Aircraft Co., June 1968
- LRO DIVINER Lunar Radiometer Experiment, <https://www.diviner.ucla.edu/science>
- K. Nandini, K. Usha, M.S. Srinivasan, M. Pramod, P. Satyanarayana, M. Sankaran, Indian Space Research Organization; Satellite Centre, “*Study on survivability of 18650 Lithium-ion cells at cryogenic temperatures*”, J of Energy Storage 17 (2018) 409-416
- S. Muthusamy, Indian Space Research Organization, “*Design framework of a configurable electrical power system for lunar rover*”, (2017), <https://www.researchgate.net/publication/321408524>
- NASA/TP-2018-219973, M. C. Gonzalez, L. W. Kohlman, and A. J. Trunek, *Cryogenic Parametric Characterization of Gallium Nitride Switches*, Glenn Research Center, Cleveland, Ohio, (2018)
- Thomas R.B. Grandjean, Jakobus Groenewald, Andrew McGordon, James Marco, Energy and Electrical Systems, WMG, University of Warwick, Coventry, CV4 7AL, UK, “*Cycle life of lithium ion batteries after flash cryogenic freezing*”, Journal of Energy Storage 24 (2019) 100804



Battery Hibernation for Surviving the Lunar Night

Presented at the 2021 Space Power Workshop

April 19, 2021

PLEASE SEE Our Other Presentation:

Power Architecture for Hibernation and Dawn Mode Operations

Contact:

Richard C. Oeftering

Power Architecture and Analysis Branch,
Glenn Research Center, Cleveland, Ohio 44135

richard.c.oeftering@nasa.gov