



Microgrid for Lunar Surface Power

Jeffrey Csank and James Soeder
NASA Glenn Research Center
Cleveland, OH

LSIC Surface Power Focus Group
March 2021



Earth

Moon

Mars



Notional Commercial Platform

ISS

Commercial launch Vehicles



Orion



SLS



Commercial Lunar Lander



Robotic Surface Missions



Lunar Orbital Platform - Gateway
PPE- Habitat - Airlock - Logistics



Mars robotic exploration, technology development

In LEO
Commercial & International partnerships

In Cislunar Space
A return to the moon for long-term exploration

On Mars
Research to inform future crewed missions

Sustainable Presence Lunar Surface Activities



Manufacture propellant

- Fuel landers for round trips between the Lunar surface and Gateway
 - Mining/excavation regolith
 - In-Situ Resource Utilization (ISRU)

Support a crew / crew operations

- Crew of four for at least 30 days stay four times per year

Other activities

- *Lunar science and technology demonstrations*

A sustainable Lunar presence will require electrical power that is highly reliable and available (Earth's Grid)

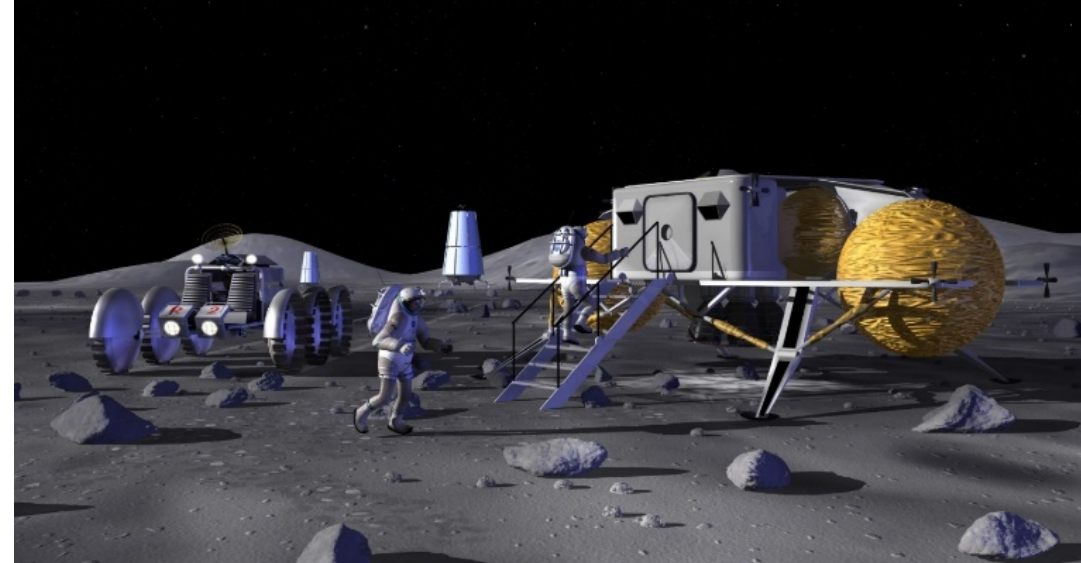
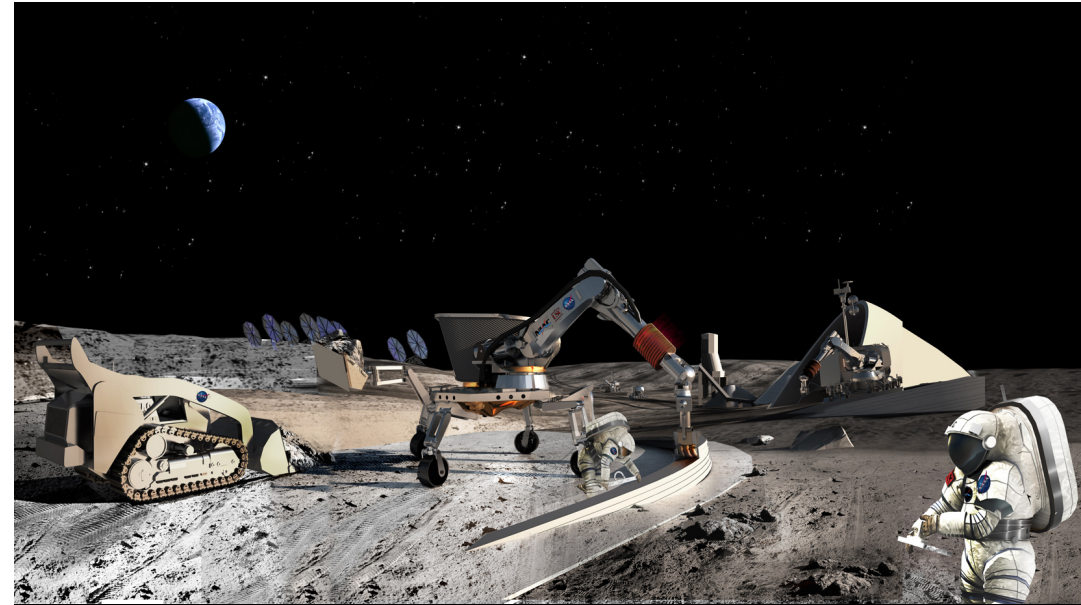

Unique Lunar Surface Sustainable Power Challenges



Power Demand

- Lunar surface power needs/uses will grow and evolve over time.
 - Power strategy (generation / energy storage) will need to evolve over time.
- Provide power availability regardless of time of lunar day.
- Accommodate distributed power system resources (mix of generation, storage, and loads)

Power System Operations

- Autonomous operation for extended periods
- Robotically deployable PMAD / power systems



Case for a Microgrid

Designing a Lunar microgrid to provide electrical power allows

- Addition of dissimilar source and storage methodologies to enhance reliability and availability
- Systematic integration of new sources and loads as the lunar base evolves
- A common grid interface for source and loads facilitate growth and interchangeability.
- Deployment of future science loads that do not need to carry their own power generation

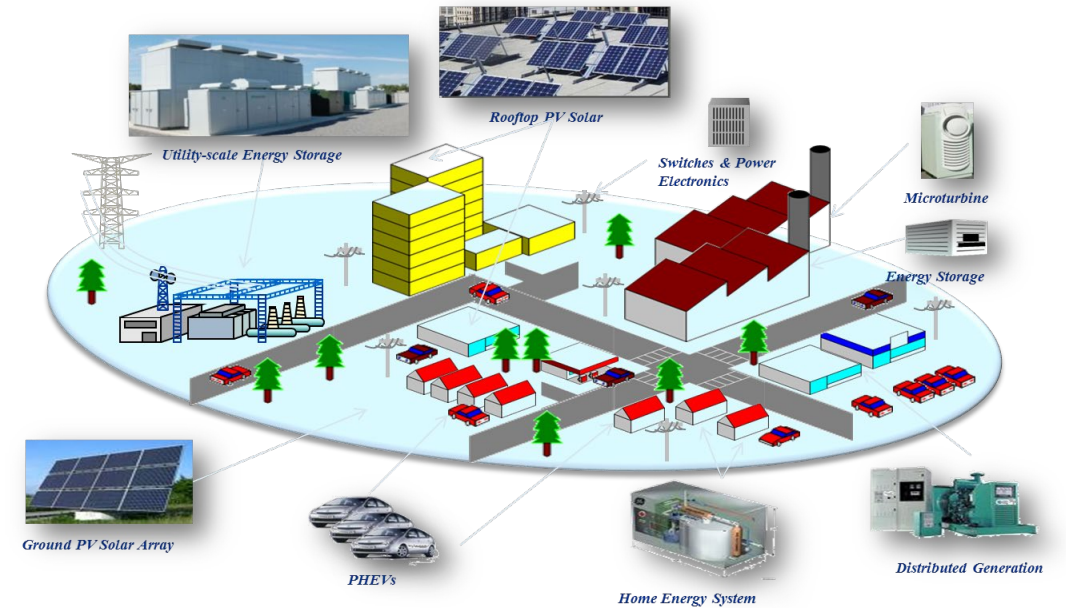

Power Sources

Solar Arrays

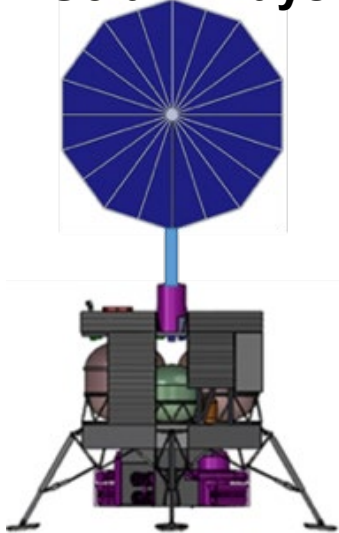

Primary Fuel Cells

Radioisotopes (RTG)

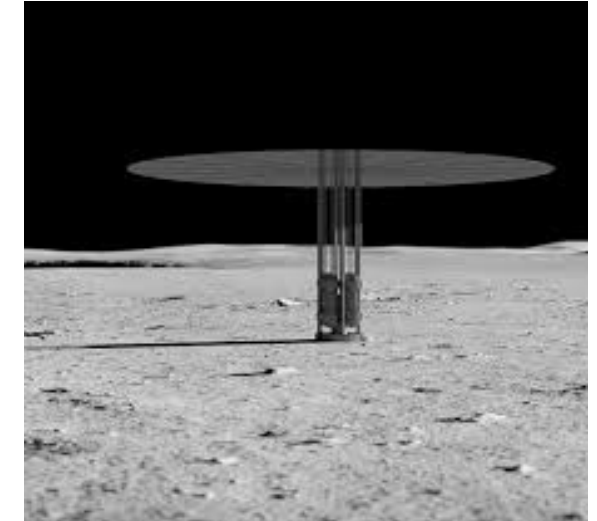

Primary Fuel Cells

Batteries

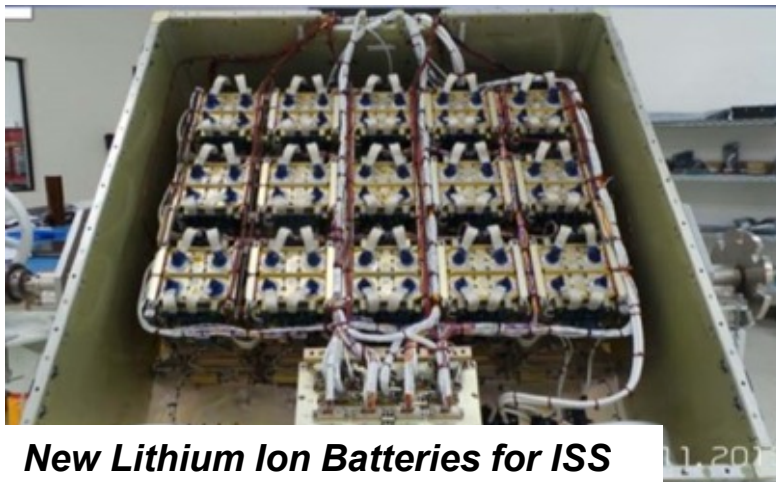

New Lithium Ion Batteries for ISS

Regenerative Fuel Cells

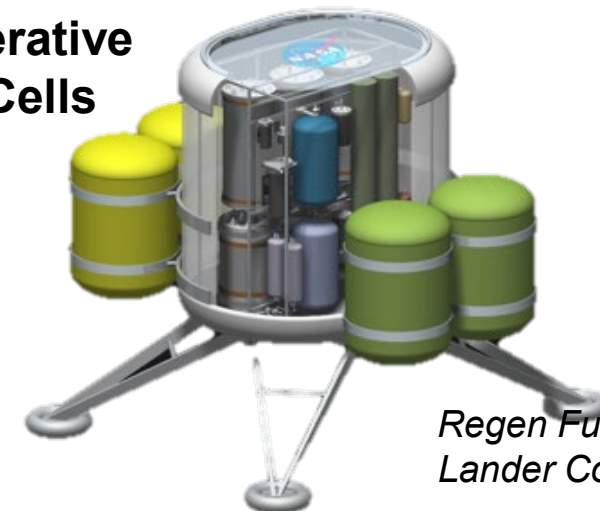

Regen Fuel Cell Lander Concept

Representative Lunar Surface

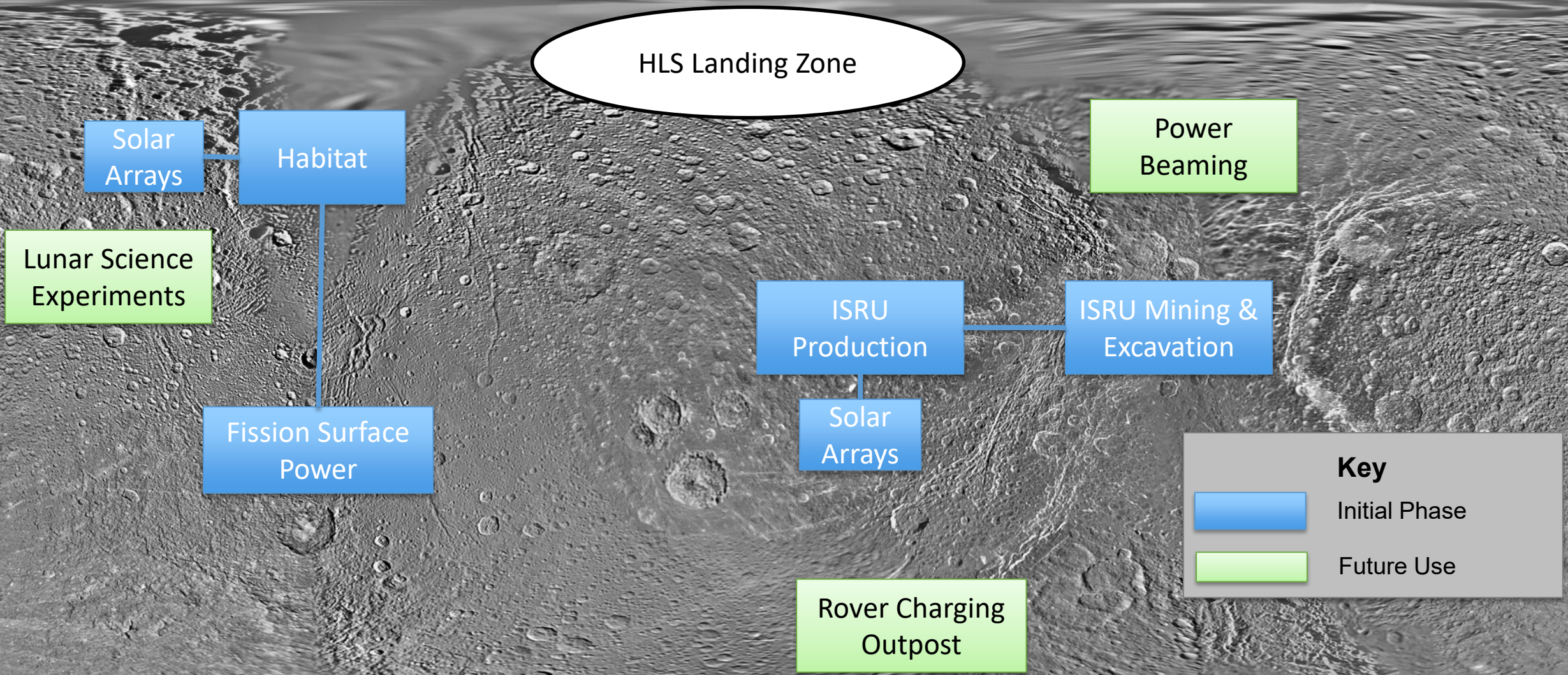

Note this is not the actual lunar surface or mapping

Microgrid Considerations



Power Distribution

- **Power Type (AC vs DC) and Voltage**
- **Grid Topology**
 - Centralized vs Distributed
 - Configuration: Ring, Star, etc
- **Power Interface Strategy**
- **Optimal Energy Storage Strategy**
- **Connectors**
 - Mating / De-mating requirements
 - High power requirements
 - Lunar Dust

Coordinate with LSIC



- **Lunar power needs beyond Habitat and ISRU**
 - Lunar science
 - Power beaming for robotic exploration of cold traps / craters
 - Rover charging outpost
- **Connectors**
 - State of the art connectors
 - Especially inductive connectors.
 - What is SOA? Power density? Efficiency?

**Thank you!!
Any Questions?**



Lunar Surface Power Connectors



Traditional Space Connectors

- High power & efficiency
- Lunar dust intolerance
- Mating / De-mating limitations

Dust Tolerant Connectors (in-testing)

- Dust tolerance
- Robotically deployable
- High power & efficiency
- Mass limitations

Inductive Connectors

- Dust tolerant
- Robotically deployable
- Less efficient
- Low maturity, especially for high power applications
- Mass limitations

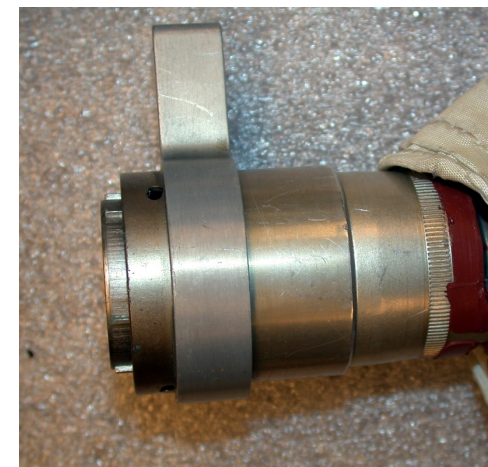
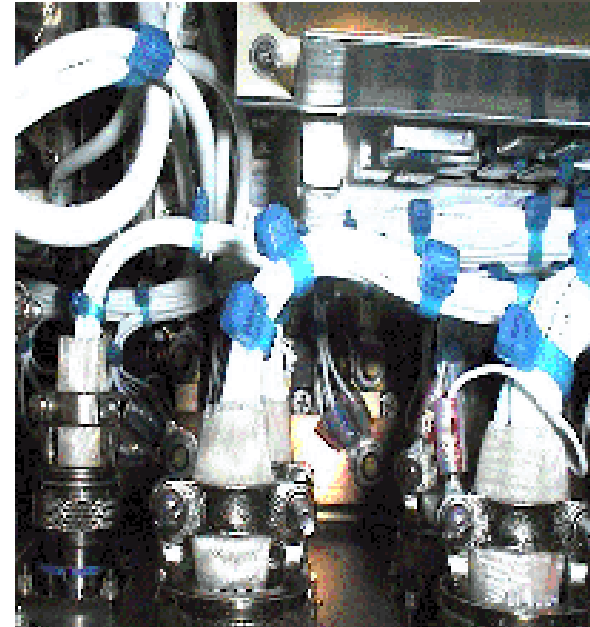

Lunar Micro-grid



Lunar Micro-grid

- Ability to integrate dissimilar power sources
 - Allows for sharing power between sources (generation/storage)
 - Increase overall reliability and availability of power
- Adds redundancy (distribution / generation)
- Evolvable / scalable / reconfigurable
 - Allows for evolution from a point to point – on power source per load to integrated system of multiple power sources serving multiple loads
 - Allows for consumers to grow and change over time.
- Micro-grid challenges
 - Standard interface for both power producers and consumers
 - System stability / power quality
 - Design parameters (voltage, etc) to maximize efficiency
 - Accommodates long term unattended operation

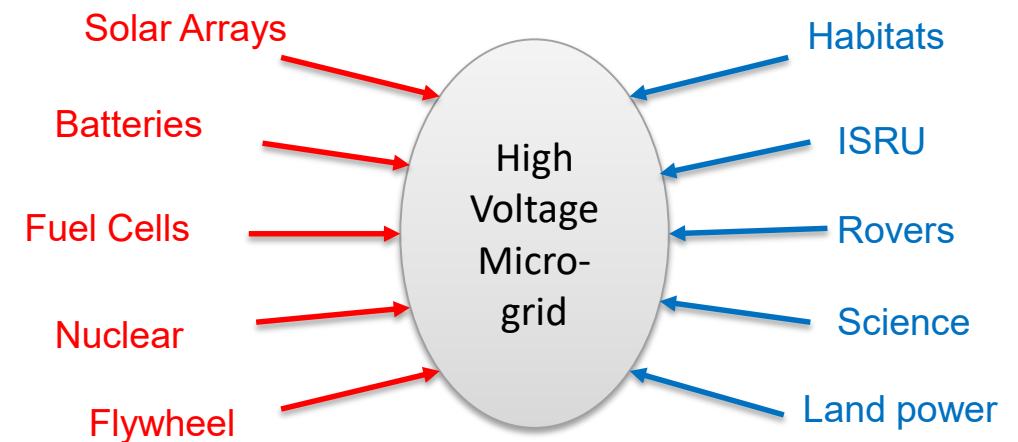

Universal Modular Interface Converter (UMIC)



UMIC

- Standardize interface to connect stationary power sources – Solar Arrays / Fission to mission loads through the micro-grid
 - Power Source to micro-grid
 - Micro-grid to loads
- Modular Converter to service loads and sources at different power levels
 - Source Voltage to Micro-grid voltage
 - Micro-grid voltage to Load voltage
 - Be power scalable based on the size of the source / load
 - Minimized spare mass (hardware can be scavenged & re-purposed)
- Must incorporate a connector that:
 - Can survive the harsh lunar environment (cold, dust)
 - EVA/EVR capable

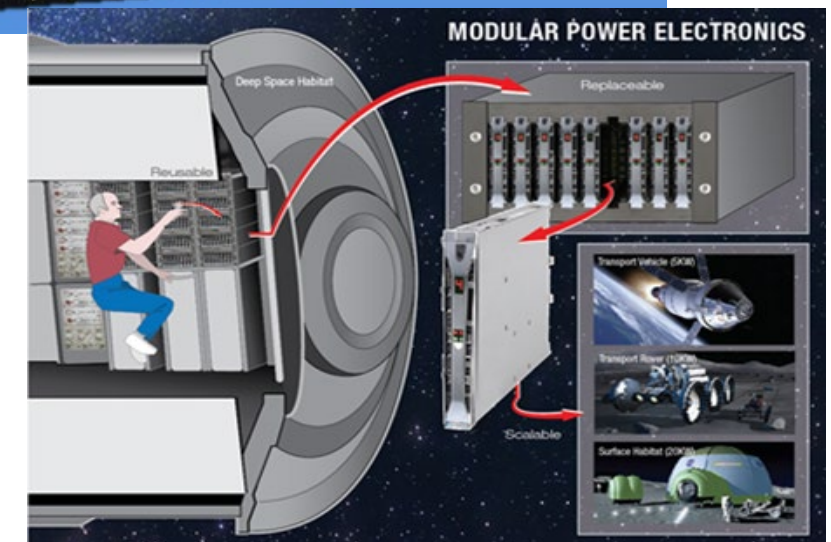



Evolution of Lunar Activities

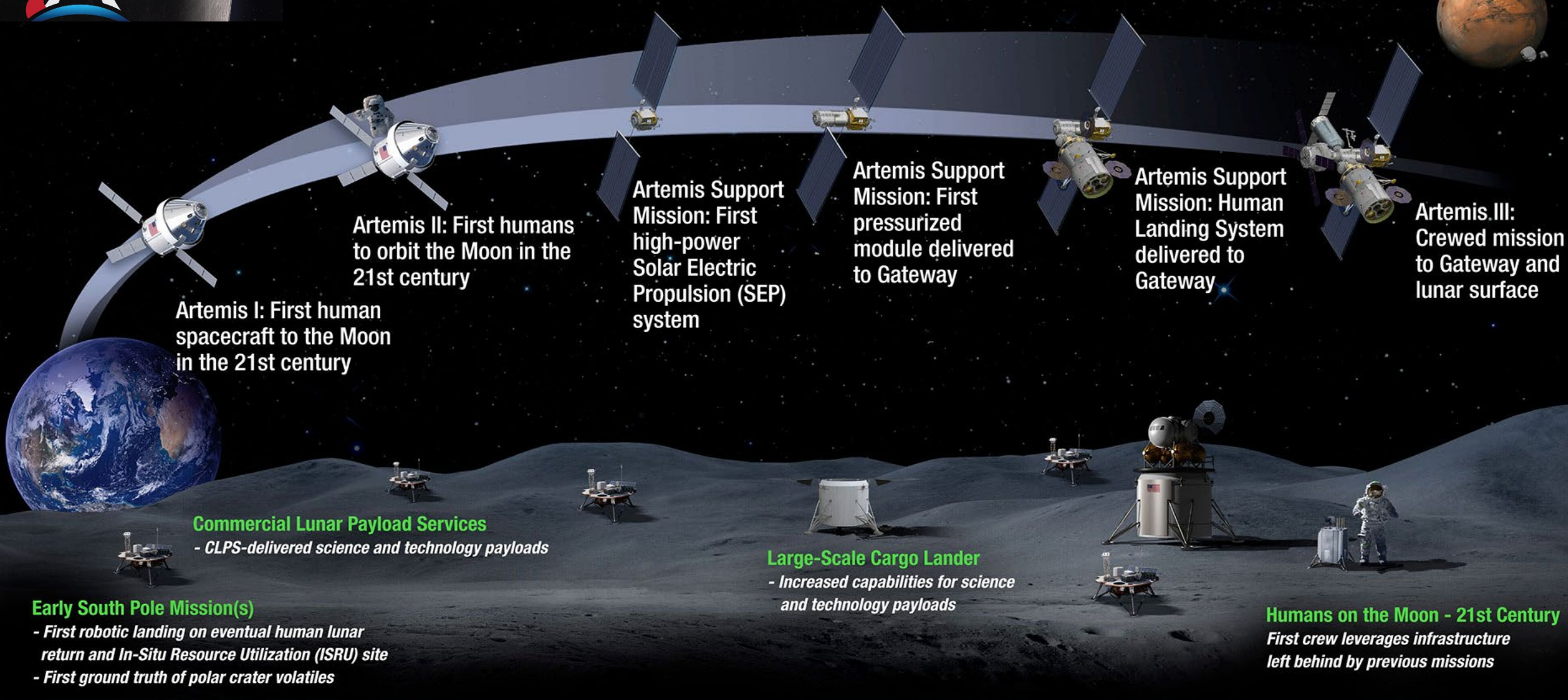

LUNAR SOUTH POLE TARGET SITE