



**Earth & Space Conference**

A Virtual Conference | April 19–23, 2021

*Engineering for Extreme Environments*



# Lunar In-Situ Resource Utilization Concept to Reality

**Pre-Conference Short Course: Engineering and Construction on the Moon**

April 19, 2021

**Julie Kleinhenz<sup>1</sup>**

**Gerald (Jerry) Sanders<sup>2</sup>**

**NASA ISRU System Capability Deputy & Lead**

<sup>1</sup>NASA Glenn Research Center

<sup>2</sup>NASA Johnson Space Center



# What Is In Situ Resource Utilization?

# What is In-Situ Resource Utilization (ISRU)?

## Living Off the Land:

ISRU involves any hardware or operation that harnesses and utilizes 'in-situ' (local) resources to create products and services for robotic and human exploration

### Resource Examples

- Water
- Oxygen
- Hydrogen
- Carbon
- Metals
- Silicon
- Nitrogen
- Regolith/Rock
- Discarded materials

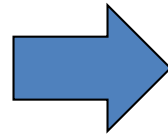

### Product Examples

- Propellant
- Life Support Consumables
- Feed stock for:
  - Additive manufacturing
  - Construction
- Agriculture substrate and/or fertilizer

- 'ISRU' is a capability involving multiple elements to achieve final products (mobility, product storage and delivery, power, crew and/or robotic maintenance, etc.)
- 'ISRU' does not exist on its own. By definition, it must connect and tie to users/customers of ISRU products and services

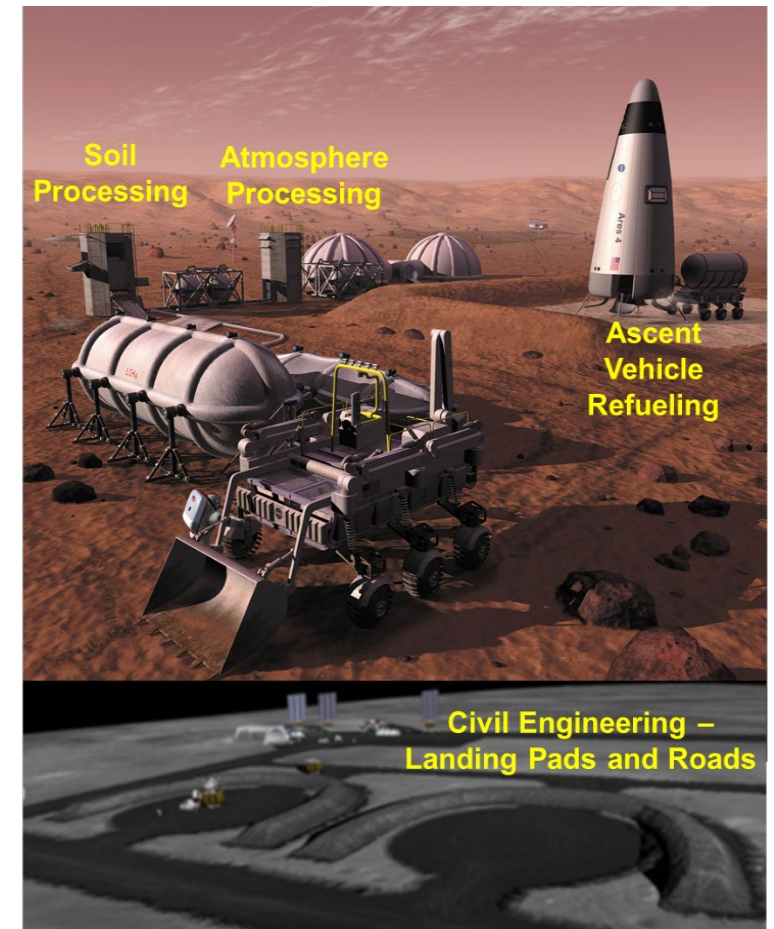

# In-Situ Resource Utilization (ISRU) encompasses:

## Resource Assessment (Prospecting)

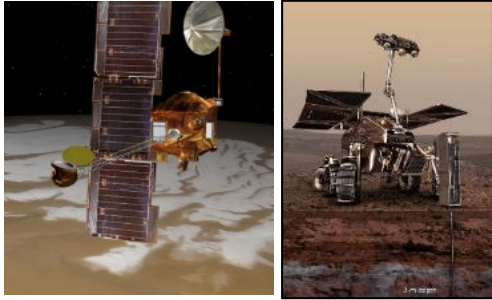

Assessment and mapping of physical, mineral, chemical, and water resources, terrain, geology, and environment

## Resource Acquisition



Drilling, excavation, transfer, and preparation/ beneficiation before processing

## Resource Processing/ Consumable Production

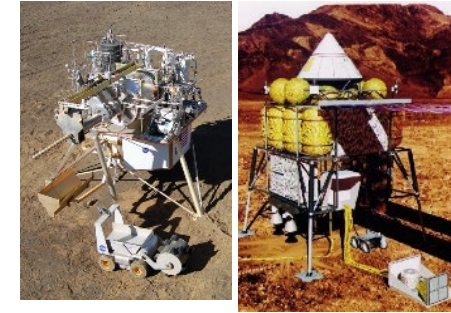

Processing resources into products with immediate use or as feedstock for construction & manufacturing

➤ Propellants, life support gases, fuel cell reactants, etc.

## In Situ Manufacturing

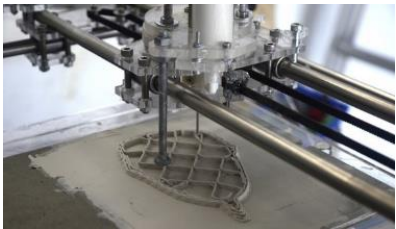

Production of feedstock potentially derived from one or more processed resources for use in manufacturing of replacement parts, complex products, machines, and integrated systems.

## In Situ Construction

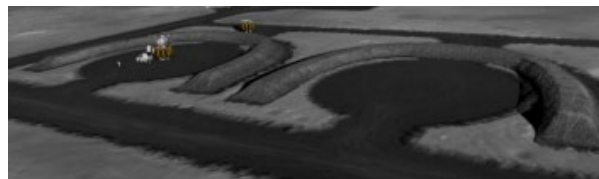

Civil engineering, infrastructure emplacement and structure construction using materials produced from in situ resources

➤ Radiation shields, landing pads, roads, berms, habitats, etc.

## In Situ Energy



Generation and storage of electrical, thermal, and chemical energy with in situ derived materials

➤ Solar arrays, thermal storage and energy, chemical batteries, etc.

# Lunar In Situ Resource Utilization 'Prospect to Product'



## Resource Assessment – Looking for Water/Minerals



Global Assessment

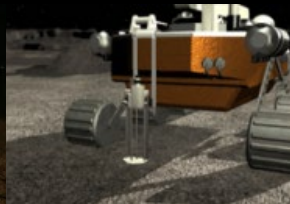

Local Assessment

## Mining Polar Water & Volatiles

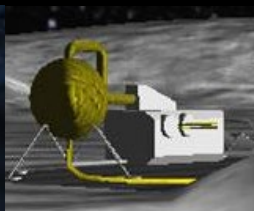

## Landing Pads, Berms, Roads, Shielding and Structure Construction

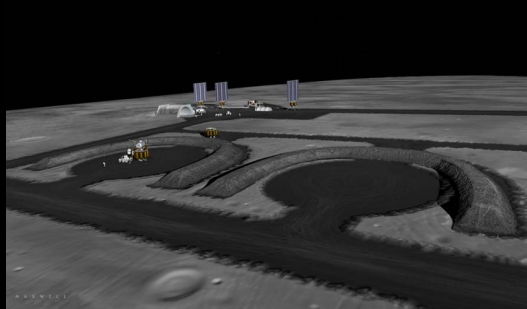

## Excavation & Regolith Processing for O<sub>2</sub> & Metal Production

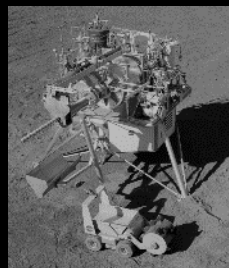

## Consumable Storage & Delivery

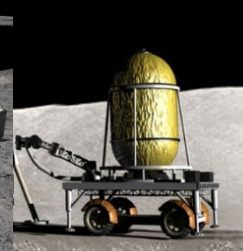
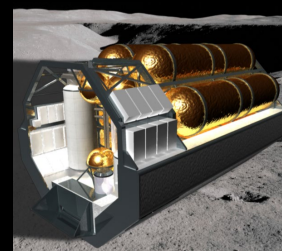

## Consumable Users

### Rovers & EVA Suits

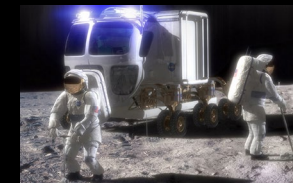

### Habitats & Life Support



### Landers & Hoppers



**Implementing ISRU Requires Multiple Disciplines and Technical Areas to Work Together**

# ISRU is Similar to Establishing Remote Mining Infrastructure and Operations on Earth



- Communications**
  - To/From Site
  - Local
- Power:**
  - Generation
  - Storage
  - Distribution
- Transportation to/from Site:**
  - Navigation Aids
  - Loading & Off-loading Aids
  - Fuel & Support Services
- Planned, Mapped, and Coordinated Mining Ops:**
  - Areas for: i) Excavation, ii) Processing, and iii) Tailings

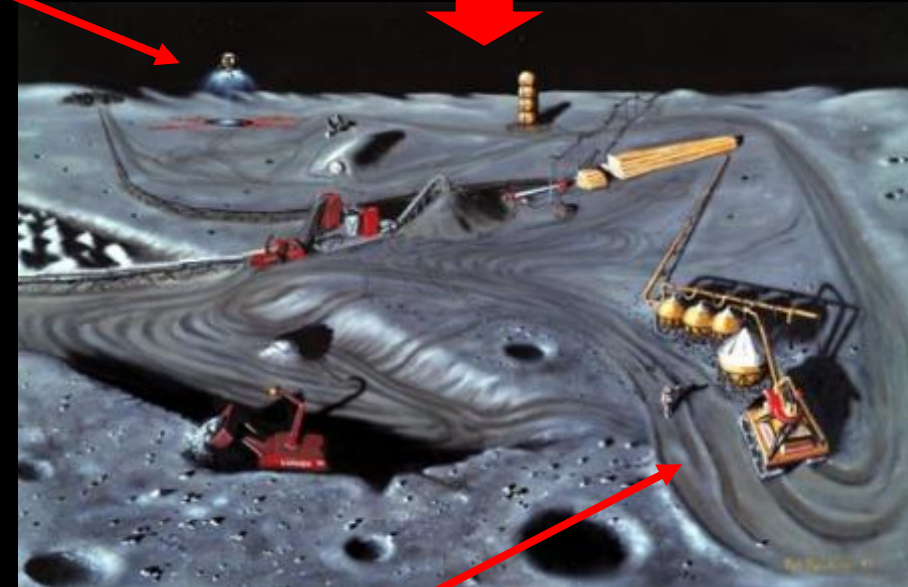
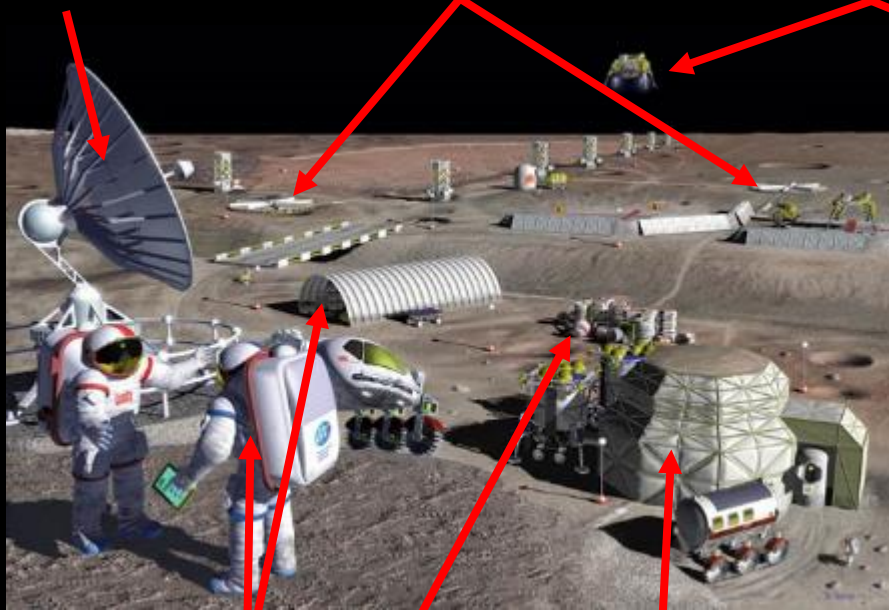

Maintenance & Repair

Logistics Management

Construction and Emplacement

Living Quarters & Crew Support Services

Roads

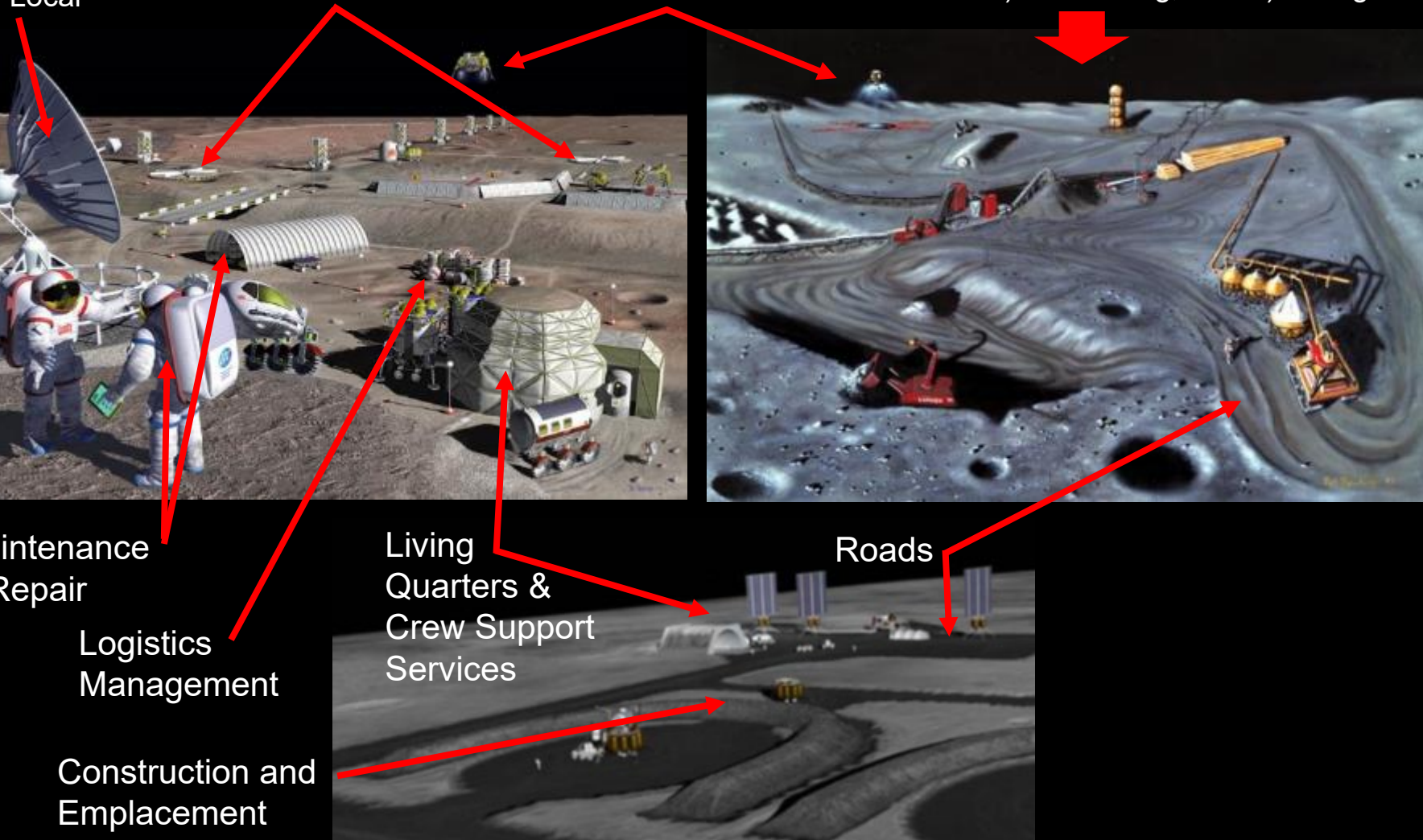
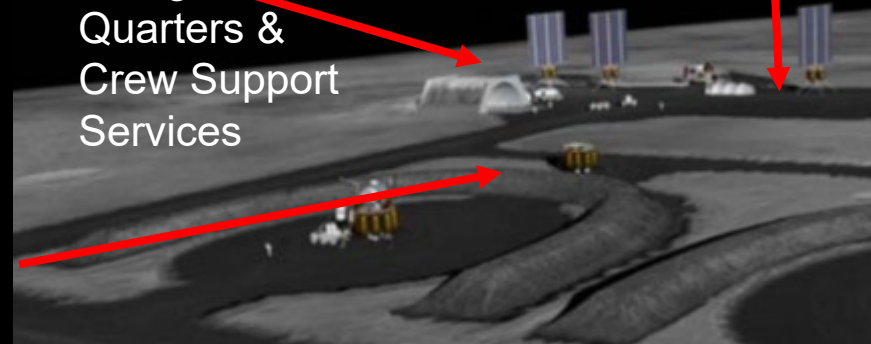



# Why ISRU?

# Why Use Space Resources?

- **They can reduce mission and architecture mass and costs**
  - **Launch mass savings:** 1 kg on Moon/Mars = 7.5 to 11 kg launched into Earth orbit
  - **Reduce launch numbers:** lower mass = less launches (also less launches reduces mission risk)
  - **Supports reuse of mission transportation assets:** reuse = lower cost; single stage landers possible
  - **Supports terrestrial industry/Enables space commercialization:** reduces risk for industry involvement thereby reducing development and life cycle costs
- **They can increase safety for crew and mission success**
  - **Ensure crew safety:** dissimilar redundancy for life support consumables, *in situ* repairs, radiation shielding, increased independence for Earth logistics
  - **Provide critical solutions for mission assurance:** safe landing zones preparation, extra propellant for return to Earth (leakage/storage failure), protective shielding
  - **Minimizes impact of shortfalls in other system performance :** launch and lander propulsion performance, life support system closure
  - **Enhance crew psychological health:** provides knowledge and tools for self-reliance and survival; larger habitats
- **They can enhance or enable mission capabilities not possible without them**
  - **Mission life extensions and enhancements:** local supply of critical consumables without waiting for new Earth supply, repairs with local materials, repurposing of end-of-life hardware, trash disposal (propellants and planetary protection),
  - **Increased surface mobility and access:** surface hoppers, ISRU produced reactants for surface mobility fuel cell power, extend duration of exploration activities in extreme environments
  - **Increased science:** more mass for science equipment, greater surface access, ISRU excavation
- **Learning to use Space Resources can help us on Earth**
  - Renewable Energy/CO<sub>2</sub> Reduction, Recycling/Repurposing, Water cleanup, Environmentally-friendly mining and construction

# Settling the West: Analogy

We wouldn't have gotten far if we couldn't use the local resources

## HAYBURNER ANALOGY

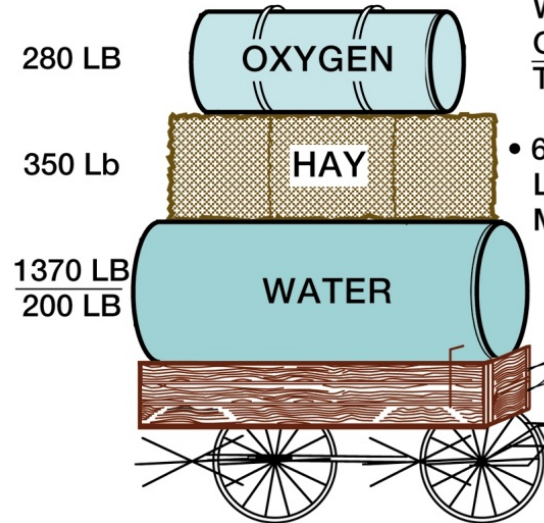
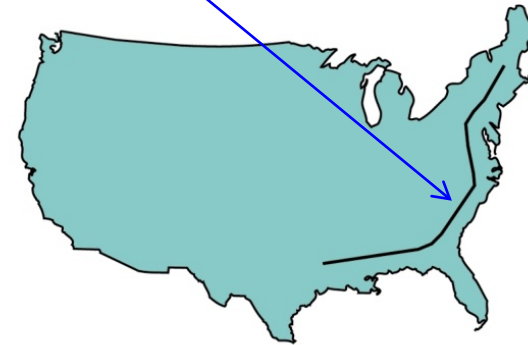

- MULE CONSUMABLES

HAY	15 LB/MULEDAY
WATER	58 LB/MULEDAY
OXYGEN	12 LB/MULEDAY
<b>TOTAL</b>	<b>85 LB/MULEDAY</b>

- 6 MULES CAN PULL LIGHT WAGON WITH 2000 LB MAXIMUM LOAD 25 MILES/DAY

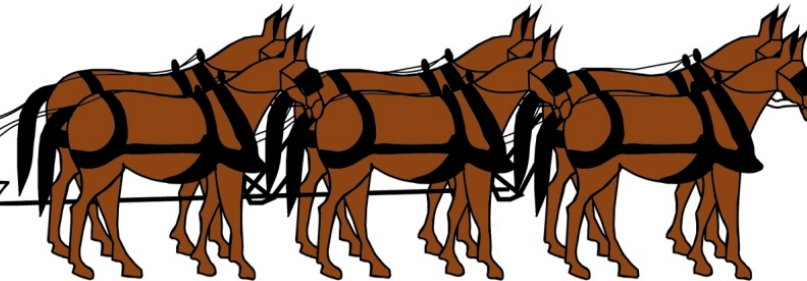

CD-93-63713

- $$\frac{(2000 \text{ LB}) \times (25 \text{ MILES/DAY})}{(6 \text{ MULES}) \times (85 \text{ LB/MULEDAY})} = \text{RANGE}$$

- MAXIMUM RANGE = 100 MILES

# How Making Propellants on Planetary Surfaces Saves on Launches and Cost (Gear Ratio Effect)

**Every 1 kg of propellant made on the Moon or Mars saves 7.4 to 11.2 kg in LEO**

**Potential >283 mT launch mass saved in LEO = 3+ SLS launches per Mars Ascent**

- Savings depend on in-space transportation approach and assumptions; previous Mars gear ratio calculations showed only a 7.5 kg saving
- 25,000 kg mass savings from propellant production on Mars for ascent = 187,500 to 282,500 kg launched into LEO

## Mars Crew Ascent Mission

- Oxygen only                      75% of ascent prop. mass: 20 to 23 mT
- Methane + Oxygen            100% of ascent prop. mass: 25.7 to 29.6 mT

## Moon Lander: Surface to NRHO

- Crew Ascent Stage (1 way): 3 to 6 mT O<sub>2</sub>
- Single Stage (both ways): 40 to 50 mT O<sub>2</sub>/H<sub>2</sub>

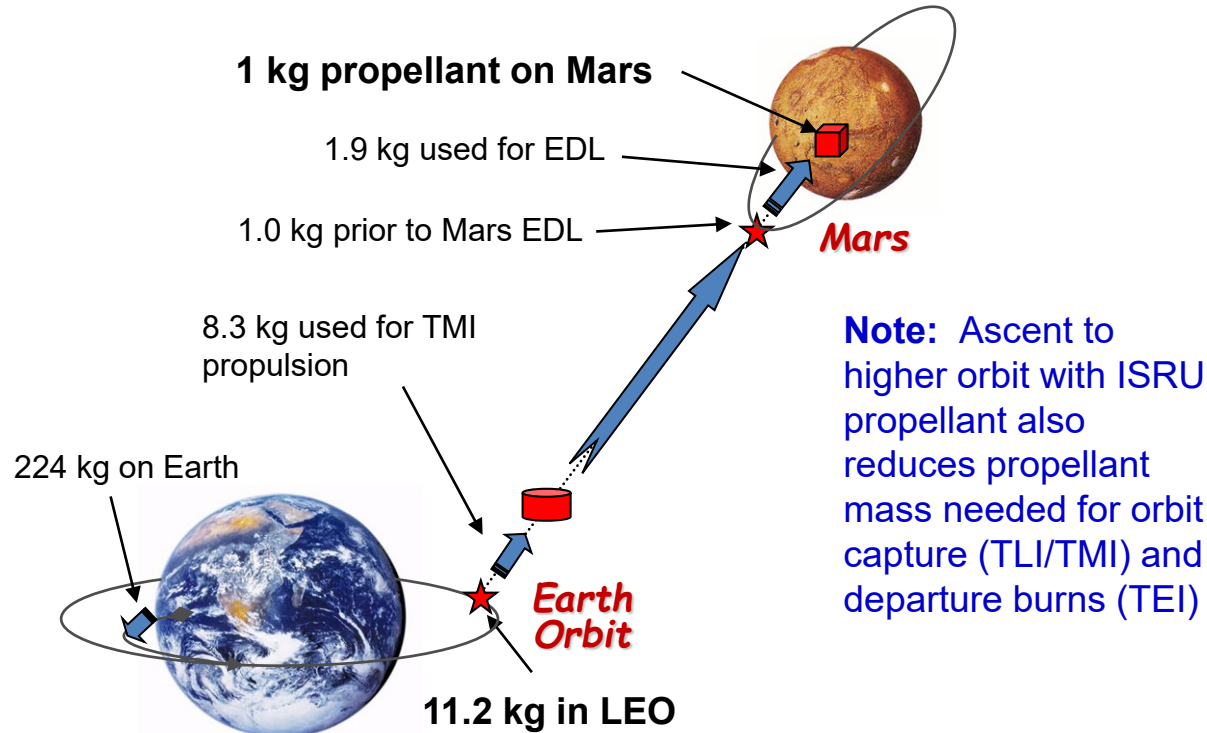

Estimates based on Aerocapture at Mars

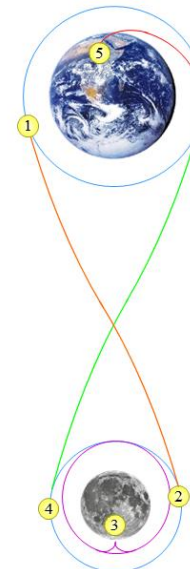

- 1 LEO
- 2 Lunar Destination Orbit
- 3 Lunar Surface
- 4 Lunar Rendezvous Orbit
- 5 Earth Surface

A Kilogram of Mass Delivered Here...	...Adds This Much Initial Architecture Mass in LEO	...Adds This Much To the Launch Pad Mass
Ground to LEO	-	20.4 kg
LEO to Lunar Orbit (#1→#2)	4.3 kg	87.7 kg
LEO to Lunar Surface (#1→#3; e.g., Descent Stage)	7.5 kg	153 kg
LEO to Lunar Orbit to Earth Surface (#1→#4→#5; e.g., Orion Crew Module)	9.0 kg	183.6 kg
Lunar Surface to Earth Surface (#3→#5; e.g., Lunar Sample)	12.0 kg	244.8 kg
LEO to Lunar Surface to Lunar Orbit (#1→#3→#4; e.g., Ascent Stage)	14.7 kg	300 kg
LEO to Lunar Surface to Earth Surface (#1→#3→#5; e.g., Crew)	19.4 kg	395.8 kg

# Benefits of ISRU Increase with Usage and Reusability

## ISRU for Lunar Ascent/Descent & Other Destination Use

Deliver O<sub>2</sub>/Fuel or Water to Depots for usage elsewhere

- Return to Earth (cis-lunar)
- Delivery to LEO
- NEO's and Mars

**Requires reusable single stage lunar lander w/ substantial payload capability**

- **Cryos vs Water**

## ISRU for Lunar Ascent/Descent & Global Surface Exploration

Produce O<sub>2</sub> & Fuel

- Requires reusable single stage lunar lander
- Does not require orbital depot for ascent/descent if both O<sub>2</sub> & fuel can be produced on the surface

## ISRU For Lunar Ascent Only

Propellant for Ascent Only; Descent Propellant from Earth or Orbital Depot

Approach considered for Constellation & most Lunar architecture studies since it supports two stage non-reusable lander concepts from start

**The greater the Delta-V of maneuvers performed by ISRU-derived propellants, the greater the benefit**

# ISRU Has Significant Influence on Other Mission Elements

## ISRU Must Be Considered from the Start or Benefits and Cost Reductions are Minimized

	Without ISRU	With ISRU
<b>Propulsion</b>	Propellant selection based on development cost and performance	Propellant selection based on ISRU products from available resources
	Propulsion cycle (pressure vs pump) based on development cost and performance	Production cycle based on influence of ISRU on Delta-V and reusability
	Non-reusable or limited reusability with Earth supplied propellants and depots	Reusability with single stage landers possible
<b>Life Support</b>	Air and Water recycling technologies and systems based on maximizing closure of oxygen and water loops	ISRU products can reduce the level of closure required, thereby reducing development cost and system complexity
	Trash/waste processing aimed at maximizing water extraction and minimizing oxygen usage	Trash/waste transferred to ISRU to maximize fuel production and minimize residuals. Trash processing hardware can be minimized to some level of drying
<b>Habitat</b>	Radiation and micrometeoroid shields based on Earth supplied materials. Storm closets to minimize mass impact	Regolith (piling or habitat burial) or in-situ water for greater radiation protection possible. This can change habitat layout and eliminate need for storm closets
	Fully constructed on Earth. Hard shell or inflatable	In-situ shelters construction possible. Consumables for inflation
	Self-contained thermal management	Use of thermal energy sharing with ISRU or creation of in-situ thermal storage for heat removal or usage
<b>Mobility</b>	Mobility primarily based on science and human activities	Mobility based on high torque/low speed excavation and civil engineering needs
	Full situational awareness and flexible navigation system	Simplified situational awareness and navigation required for ISRU applications
<b>Power</b>	Self-contained units. Solar array and batteries	Distributed power generation and storage, esp. fuel cell reactant storage and regeneration
	Fuel cell reactant based on regeneration technique alone	Fuel cell reactant based on in-situ resources available
	Increase in power generation is a function of delivery from Earth	In-situ growth of power thru fuel cell consumable, in-situ thermal, and in-situ manufacturing



# Pros & Cons of Human Exploration with ISRU

## Pros

## Cons

Enables Reusability & Flexibility	Higher initial risk
Increased delivered payloads/reduced consumables from Earth	Higher upfront costs
Interdependence – common hardware, interfaces, and standards	Interdependence - common failure modes across multiple subsystems
Long-term growth/reduced life cycle costs	Does not benefit short trips/stays
Linked objectives w/ Science; increased Science rationale and capabilities	Concern about impacting lunar environment for science
Supports Commercial involvement/reduced costs	International agreement/Legal issues
Mars Forward	Infusion into architectures must consider from start
Public Outreach & Interest. Not repeating Apollo	
Technology Spin-In and Spin-off	



# Lunar Resources

What is available and what can we do with it?

# Lunar Resources



## Lunar Regolith

- **>40% Oxygen by mass**
  - Silicate minerals make up over 90% of the Moon
- Regolith
  - Mare: Basalt (plagioclase, pyroxene, olivine)
  - **Highland/Polar: >75% anorthite, iron poor**
- Pyroclastic Glass
- KREEP (Potassium, Rare Earth Elements, Phosphorous)
- Solar Wind Implanted Volatiles

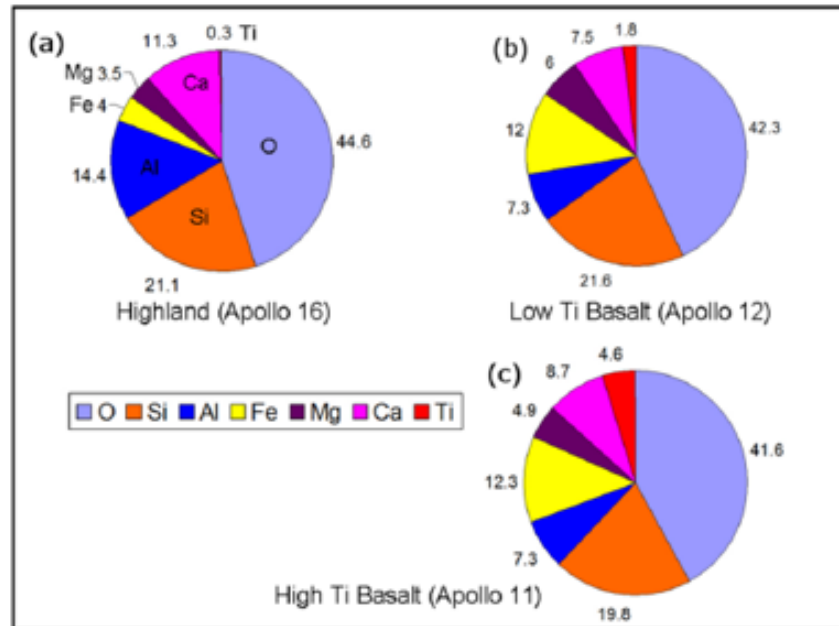

From Lunar Sourcebook

## Polar Water/Volatiles

- LCROSS impact estimated **5.5 wt%** water along with other volatiles
- Green and blue dots show positive results for surface water ice and temperatures <110 K using orbital data.
  - *Without direct measurements, form, concentration, and distribution of water is unknown*

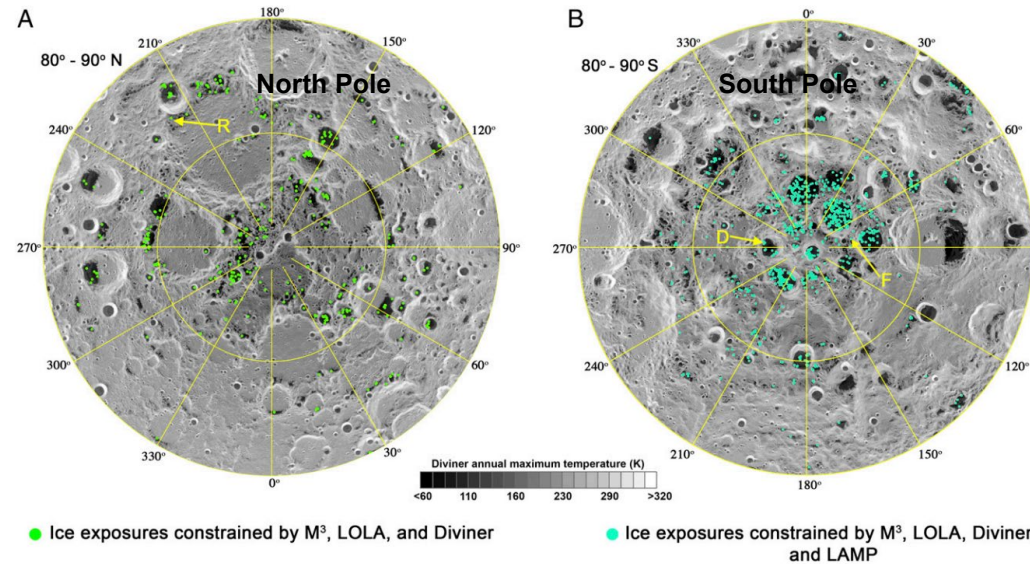

Li et. al, (2018), *Direct evidence of surface exposed water ice in the lunar polar regions*

	Concentration (% wt)*
H <sub>2</sub> O	5.5
CO	0.70
H <sub>2</sub>	1.40
H <sub>2</sub> S	1.74
Ca	0.20
Hg	0.24
NH <sub>3</sub>	0.31
Mg	0.40
SO <sub>2</sub>	0.64
C <sub>2</sub> H <sub>4</sub>	0.27
CO <sub>2</sub>	0.32
CH <sub>3</sub> OH	0.15
CH <sub>4</sub>	0.03
OH	0.00
H <sub>2</sub> O (adsorb)	0.001-0.002
Na	

Table courtesy of Tony Colaprete

# Uses of Lunar rocks & minerals



Anorthite  
 $\text{CaAl}_2\text{Si}_2\text{O}_8$



Pyroxene  
 $(\text{Ca},\text{Mg},\text{Fe})\text{Si}_2\text{O}_6$



Olivine  
 $(\text{Mg},\text{Fe})_2\text{SiO}_4$



Ilmenite  
 $\text{FeTiO}_3$

Al

Si

Ca

O

Mg

Fe

Ti

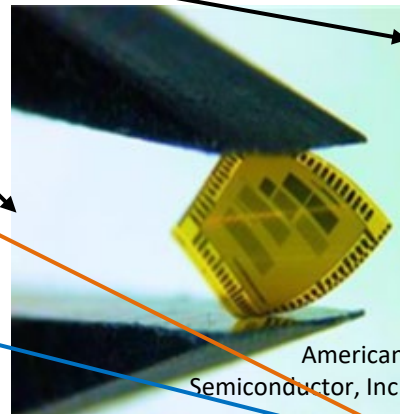

American Semiconductor, Inc.



Made In Space

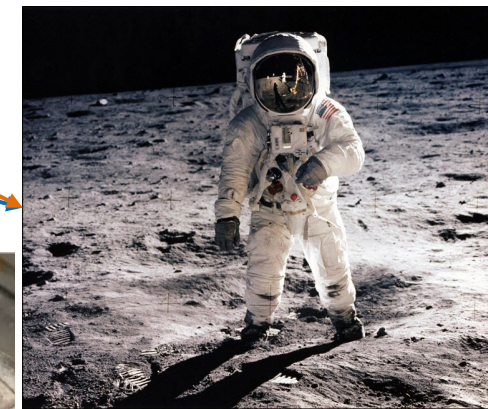
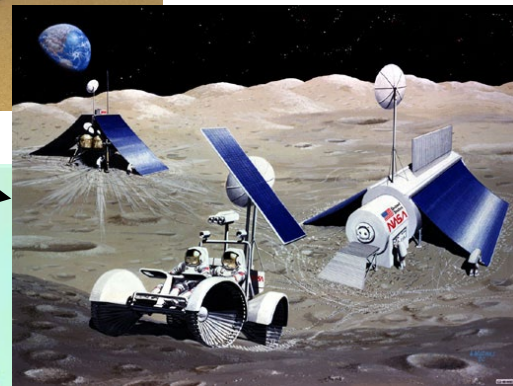



# Lunar Resources for Propellant production

	Oxygen from Regolith	Water
Availability	Minerals in any surface regolith	Localized ice-stability regions only (e.g., cold traps); subsurface
Yield	1% to ~10% depending on method	Anticipated < 10% (5% max for most tech)
Extraction temperature	~1000°C	~100°C
Reaction catalyst	Most processes require reactant gas to initiate	None, only heat required
Accessibility	Any surface regolith	Subsurface regolith, Cold regions only: shadowed crater likely
Knowledge state	Returned Apollo samples and meteoroids	Orbital indicators & LCROSS: no ground truth yet
Return on Investment	Oxygen provides 75%- 80% of chemical propellants, fuel required from earth.	All propellant provided (fuel and oxidizer).
Complimentary benefits	Reacted byproduct has high potential as construction feedstock	Direct use of water for: radiation protection, food production, etc.



# What we know about the water...

This is the hot topic, so let's take a minute to talk about what we know

# Potential Water Sources

- 1. Surface “frost”:** Very low grade, but located exactly at the surface.
  - While easy to access, it likely does not meet ISRU criteria (production requirements)
  - However, knowledge of surficial water can be an indicator of shallow bulk water (may provide geologic context)
- 2. Pyroclastic water deposits:** Low grade (max. 500 ppm), water bound in silicate glasses
  - Not of interest to ISRU, does not meet ISRU criteria (production requirements) and requires higher energy to extract (over ice)
  - However, these deposits exist at low latitude and could be relevant to other mission architectures

- 3. Shallow bulk water:** moderate grade (up to 5 wt%) beneath 10 to 30 cm desiccated layer
  - **Highest ISRU potential:** meets ISRU criteria particularly in terms of production and accessibility requirements
  - Note that deposits may be irregularly distributed, occupying only 30% to 40% by area

- 4. Deep bulk water:** Potentially high grade, at depths >1 m
  - Potential for ISRU, but does not meet current ISRU accessibility criteria:
    - Would require alternate technologies and grade must be substantial
  - No validated way of mapping/identifying deposits deeper than 1 m (possibly use seismic, GPR)

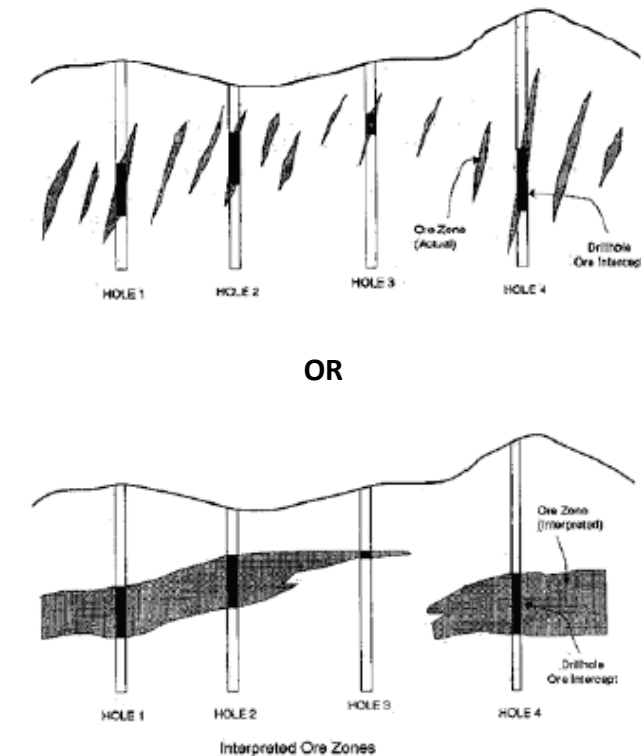
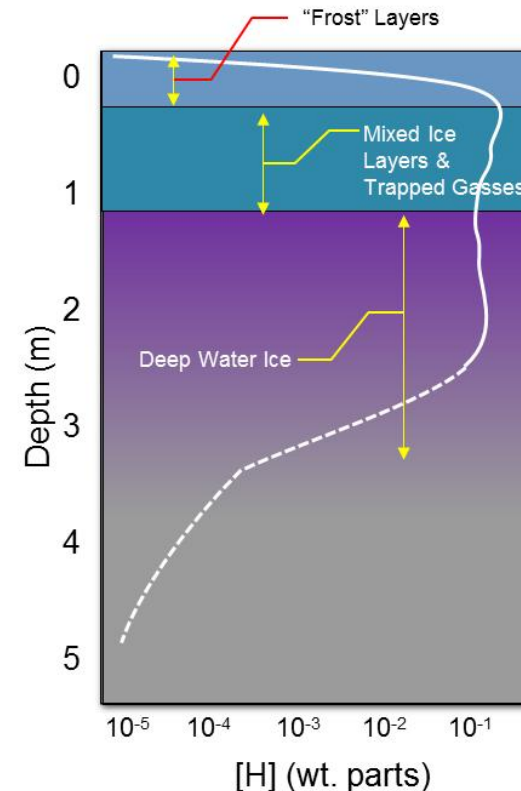

# Current knowledge state: Shallow Bulk Lunar Polar Water

## Shallow bulk water is the target for ISRU.

- Potential lunar water sources include: surface frost, shallow bulk water, deep bulk water, and pyroclastic deposits
- There are 4 data sets for shallow bulk water (LCROSS, Chandrayaan-1, LRO, LP; see chart)
  - There are more data sets for surface frost detection (e.g., LAMP, LOLA and M3) than other data sets. While surface frost may be a geologic indicator of deeper water, there is currently no strong correlation between the two types of data sets (surface vs. buried reservoirs)

## Water Equivalent Hydrogen (neutron spectroscopy) cannot give accurate concentration or depth distribution

- NS flux indicates there is hydrogen somewhere between the surface down to about 80 cm to 100 cm
- Conversion to WEH assumes uniform distribution laterally and with depth, and that all H is bound in water
- Is a function of assumptions regarding desiccated layer: concentration may be higher, but at depth

## While regional distribution can be mapped from orbit significant local heterogeneity is expected

- Using Neutron Spectrometer: ~50 m to 150 m (expected heterogeneity scale based on cratering statistics)

## Radar data (CPR\*) may suggest potential large volumes of water, but surface roughness can produce a similar signal.

## Resolutions from current data sets are insufficient for Reserve definition.

- Reserve definition requires high resolution observation of a particular resource
- Current instruments and vantage points were designed with science objectives in mind.

Source	Sensing Depth	Resolution	Concentration	Extent	Comments
LCROSS	3 to 5 m	Single 50 m sample to 5m deep	5.5 wt%, with other species	Single location	Consistent with the LP NS if distributed at 30 to 40% and/or buried under 10 to 30 cm desiccated layer
Chandrayaan -1 and LRO: RADAR CPR*	~1 to 2 m	150 m (baseline) up to 15 m (zoom- azimuth)	Wavelength scale ice blocks	Some PSRs	Source of high total volume estimates Could also be surface roughness
LP and LRO: Neutron count	0.8 to 1 m	LP: ~45 km at 30 km alt. LRO: ~75 km at 50 km alt. (STN) ~10 km at 50 km alt. (CSETN)-controversial	0.2 to several wt%	Poleward of 80°	Low resolution, deriving concentration depends on assumption of small scale and vertical distribution

# Lunar Water Reference Cases

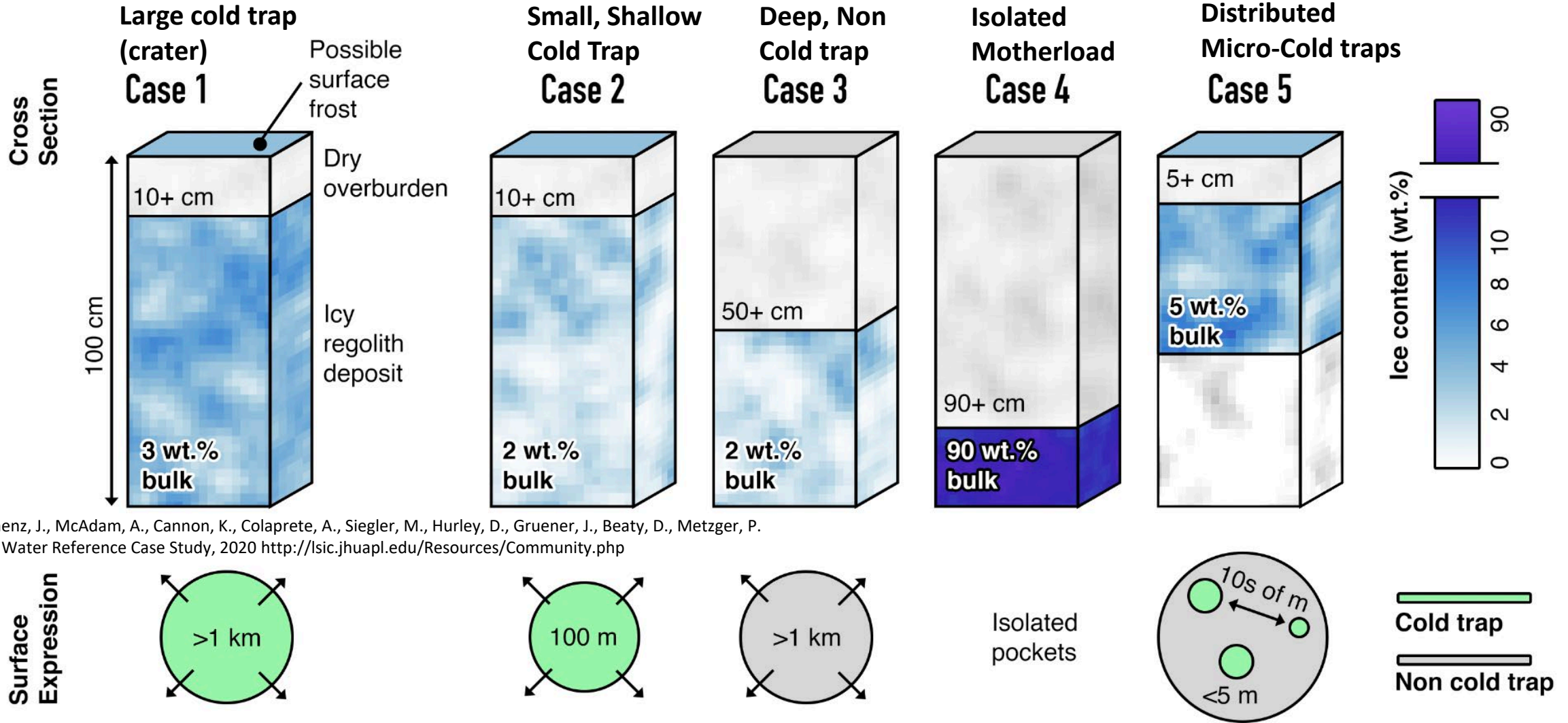

Kleinhenz, J., McAdam, A., Cannon, K., Colaprete, A., Siegler, M., Hurley, D., Gruener, J., Beaty, D., Metzger, P.  
 Lunar Water Reference Case Study, 2020 <http://lsic.jhuapl.edu/Resources/Community.php>

Below 2m there is potential for water ice ~10 wt% that could extend to thermal boundary layer (5m - 10m).  
 The condition define at 1m for these cases is likely to extend deeper.

# Threshold Criteria for a Reserve

## ISRU System

ISRU Requirement	Criteria
Water Concentration	≥2 wt% to a 1 wt% detection limit
Water Depth distribution	5 to 100 cm, ≤10 cm increments
Overburden depth	5 to 50 cm ≤10 cm increments
Lateral distribution	500 m radius
Target yield	15 tons water per lander

- Criteria according to current ISRU system models which use current technologies and architecture concepts (Kleinhenz and Paz, AIAA-2020-4042)
- Criteria are highly dependent on:
  - Amount of consumables needed
  - Timeline allotted for ISRU production
  - Architecture interface to HLS (location of produced consumables, power)
  - Assumptions about mobility options and capabilities including autonomy and operational life
- Consideration to Oxygen from Regolith (O2R) as the alternative to water from ice
  - When possible, identify breakpoints where O2R is clearly advantageous over water from ice
- Additional knowledge to design ISRU systems and architectures (next page)

## Human Landing Systems

Lander Requirement	Initial	Sustained
Daylight Operations	continuous light	50 hours darkness (threshold) 191 hours (goal)
Surface Access	84° S to 90° S	global
Habitation Capability	two crew for 8 earth days	four crew lunar sortie with pre-emplaced surface infrastructure
EVA Excursion Duration	lasting a minimum of 4 hours	lasting a minimum of 8 hours
Landing Site Vertical Orientation	vertical orientation of 0 to 8° (threshold) and 0 to 5° (goal) from local vertical for surface operations.	
Landing Accuracy	landing within 100 m (3-sigma) of target landing site	
Surface Operations	operating on the lunar surface for a minimum of 6.5 Earth days	
EVA Excursions per Sortie	at least two (threshold) and five (goal) surface EVA excursions per sortie.	
Scientific Payload Return to Lunar Orbit	returning scientific payload of at least 35 kg and 0.07 m <sup>3</sup> volume (threshold) and 100 kg and 0.16 m <sup>3</sup> volume (goal)	

- For infusion of ISRU into Human campaign, the HLS site requirement must be considered
- ISRU reserves must have adequate proximity to HLS sites
- Information per HLS BAA Appendix H requirements



# ISRU Architectures and Mission Infusion

Examples of what is being considered and how ISRU would fit into exploration planning

# ISRU Propellant Production Incremental Growth

## Demonstrate, Build Confidence, Increase Production and Usage



10 to 30 mT Range for Initial Full Scale Production

	Demo Scale	Pilot Plant	Crewed Ascent Vehicle <sup>1</sup>	Full Descent Stage <sup>1</sup>	Lockheed Martin <sup>6</sup>		Dynetics <sup>6</sup> Single Stage/ Drop Tanks	Single Stage to NRHO <sup>2</sup>	Human Mars Transportation <sup>3</sup>	Commercial Cis-Lunar Transportation <sup>4</sup>
			3 Stage Arch to NRHO		2 Stage	Single Stage				
Timeframe	days to months	6 mo - 1 year	1 mission/yr	1 mission/yr	per mission	per mission	per mission	1 mission/yr	per year	per year
Demo/System Mass <sup>5</sup>	10's kg to low 100's kg	1 mt O <sub>2</sub> Pilot 1.3 – 2.5 mt Ice Mining	1400 to 2200 kg	2400 to 3700 kg				Not Defined	Not Defined	29,000 to 41,000 kg
Amount O <sub>2</sub>	10's kg	1000 kg	4,000 to 6,000 kg	8,000 to 10,000 kg	10,000 kg	33,000 kg	32,000 kg	30,000 to 50,000 kg	185,000 to 267,000 kg	400,000 to 2,175,000 kg
Amount H <sub>2</sub>	10's gms to kilograms	125 kg		1,400 to 1,900 kg	2,000 kg	7,000 kg	Methane Fuel	5,500 to 9,100 kg	23,000 to 33,000 kg	50,000 to 275,000 kg
Power for O <sub>2</sub> in NPS	100's W	~3 KW	20 to 32 KW	40 to 55 KW				N/A	N/A	N/A
Power for H <sub>2</sub> O in PSR	100's W	~2 KW		~25 KW				14 to 23 KW		150 to 800 KW
Power for H <sub>2</sub> O to O <sub>2</sub> /H <sub>2</sub> in NPS		~4 KW		~48 KWe				55 to 100 KWe		370 to 2,000 KWe

NPS = Near Permanent Sunlight

<sup>1</sup>Estimates from rocket equation and mission assumptions

PSR = Permanently Shadowed Region

<sup>6</sup>Information obtained from presentation at LSIC Supply & Demand Workshop. Presentations/videos posted at the LSIC website <http://lsic.jhuapl.edu/Events/103.php>

- Table uses best available studies and commercial considerations to guide development requirements/FOMs
- Table provides rough guide to developers and other surface elements/Strategic Technology Plans for interfacing with ISRU



# Lunar Resources for Propellant production

	Oxygen from Regolith	Water
Availability	Minerals in any surface regolith	Localized ice-stability regions only (e.g., cold traps); subsurface
Yield	1% to ~10% depending on method	Anticipated < 10% (5% max for most tech)
Extraction temperature	~1000°C	~100°C
Reaction catalyst	Most processes require reactant gas to initiate	None, only heat required
Accessibility	Any surface regolith	Subsurface regolith, Cold regions only: shadowed crater likely
Knowledge state	Returned Apollo samples and meteoroids	Orbital indicators & LCROSS: no ground truth yet
Return on Investment	Oxygen provides 75%- 80% of chemical propellants, fuel required from earth.	All propellant provided (fuel and oxidizer).
Complimentary benefits	Reacted byproduct has high potential as construction feedstock	Direct use of water for: radiation protection, food production, etc.

# Lunar Water ISRU Architecture

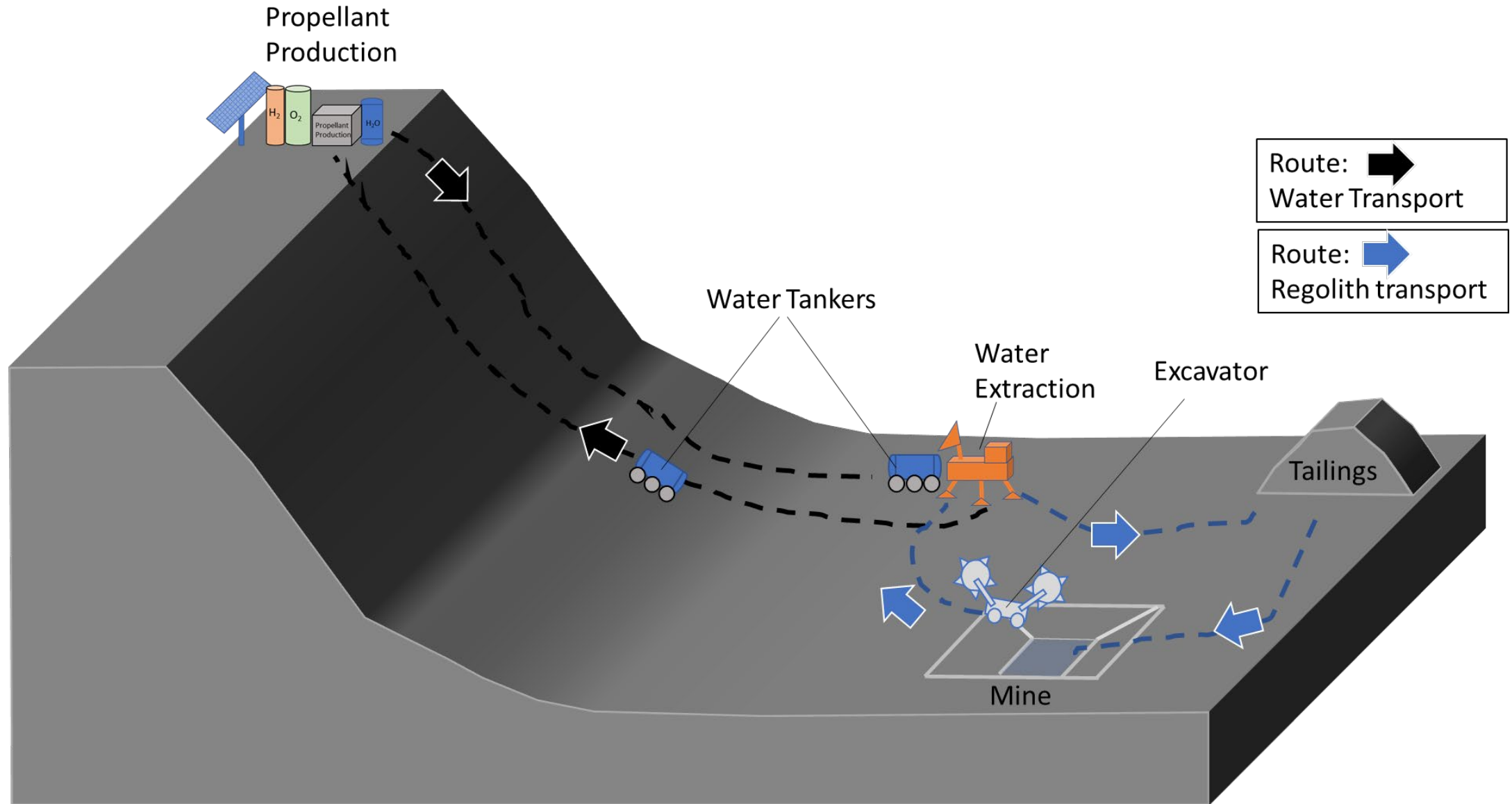

# Lunar Water ISRU Architecture

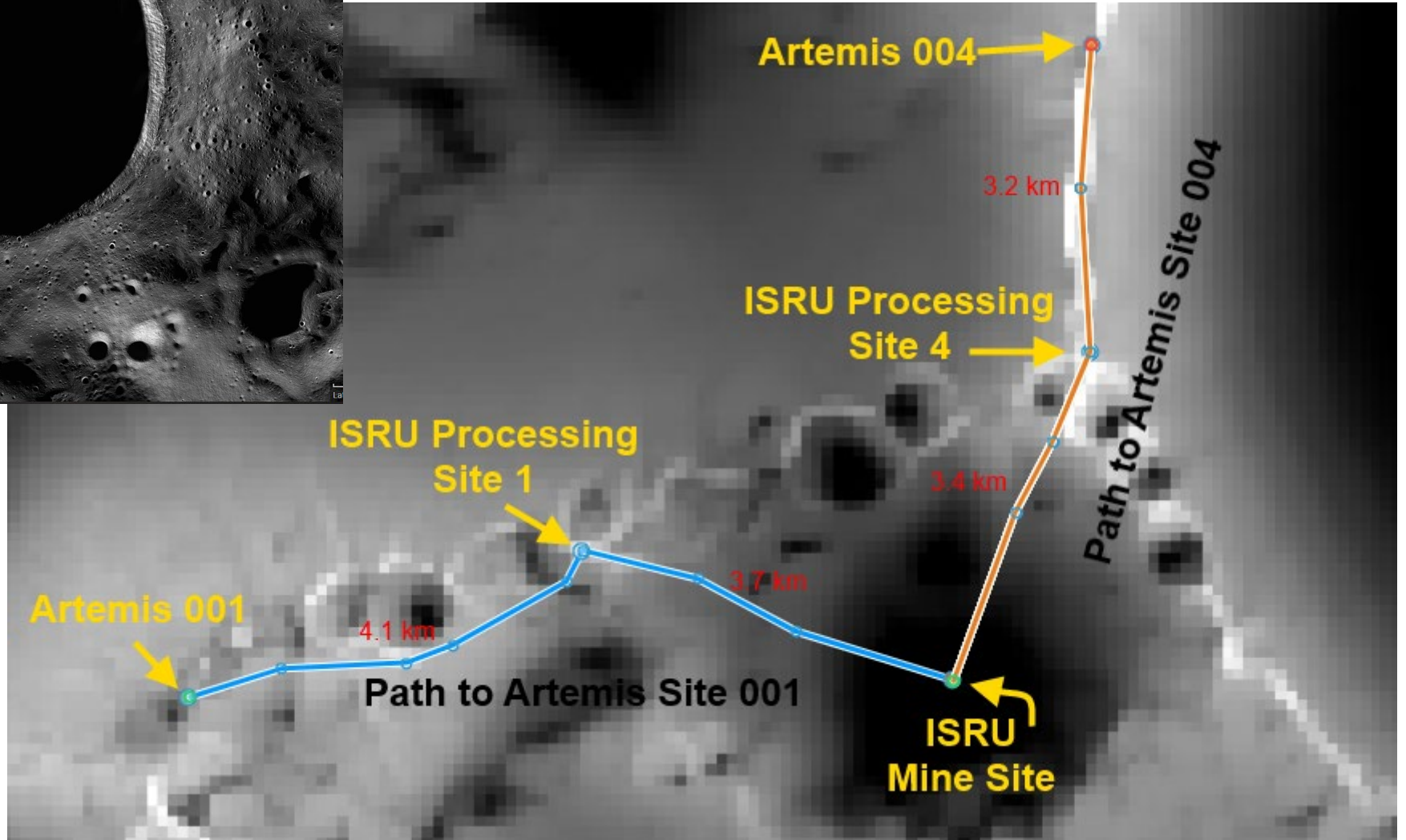
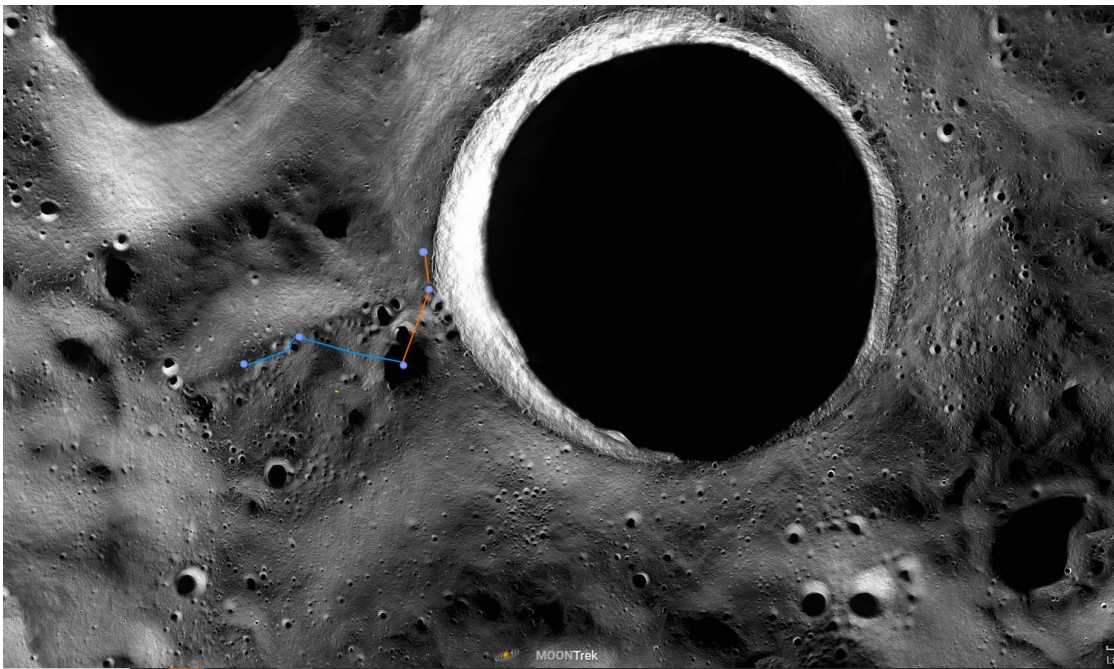

# ISRU Lunar Water System

- Production requirement is based on propellant production,  $H_2$  and  $O_2$  with a mixture ratio of 6
  - Human scale target is 10mT of  $O_2$ , 1mT for Pilot scale
  - The Oxygen requirement is stated, but hydrogen is the driving requirement, excess oxygen will be generated
- Target is water in a PSR crater of significant size (resolvable water indicate from orbital resolution)
- Transport of water out of PSR, processing at sunlit site
- Power systems are NOT included in mass.
- Packing is not addressed
- Communication and command/control systems are not explicitly addressed: Margins held

Mixture ratio (O/F)	6	Regolith density	1.3 g/cc
Mass Margins	20% growth 15% structure	PSR Traverse multiplier for hazard avoidance	1.5 x
Commissioning time	48 hr	Excavator Recharge time	5 hr
Total production time	225 days	Tanker Recharge time	10 hr
Power Margins	20% growth	Extraction Efficiency	75%
Max battery discharge	80%	Battery Energy density	140 Whr/kg

Subsystem	Technology
Excavator	RASSOR
Regolith hopper	RASSOR hopper
Water Extraction	Auger Dryer
Water Tank for water tankers	Sized: (Aluminum, 50% ullage)
Water Tanker: Mobility platform	Sized
Fluid Transfer	DTAU + COTS water pump lookup table w/flow rate
Water Tank for Electrolyzer	Sized
Water Cleanup	TBD
Electrolysis	Liquid Cathode PEM + COTS water pump lookup w/flow rate
Gas Dryer	Regenerative desiccant
$H_2$ Liquefaction	Cryocoolers: COTS
$O_2$ Liquefaction	Cyrocoolers: COTS
$H_2$ and $O_2$ Storage (Tanks)	Sized: Aluminum thin wall (3mm)

# ISRU Oxygen from Regolith System

- Oxygen from regolith system from Ref. 2 with production rate of 10 mT of oxygen
- Target oxygen from the silicate minerals in the surface regolith using a Carbothermal reaction process
  - Reduction of oxides with a carbonaceous source (Methane) at temperatures in the range of 1650 -1800°C (regolith melting temperature)
  - Methane is recycled.
- Resource is ubiquitous and in readily accessible surface material.
- System assumed to be in region of high illumination and leverages direct solar heating
  - Solar concentrator for regolith melting
  - Solar array for electrical power
- This study included lander packaging

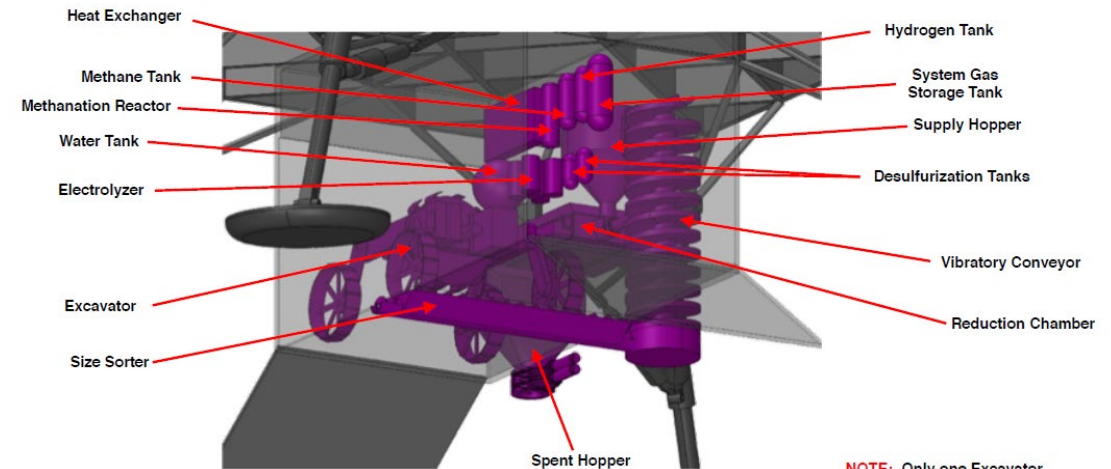
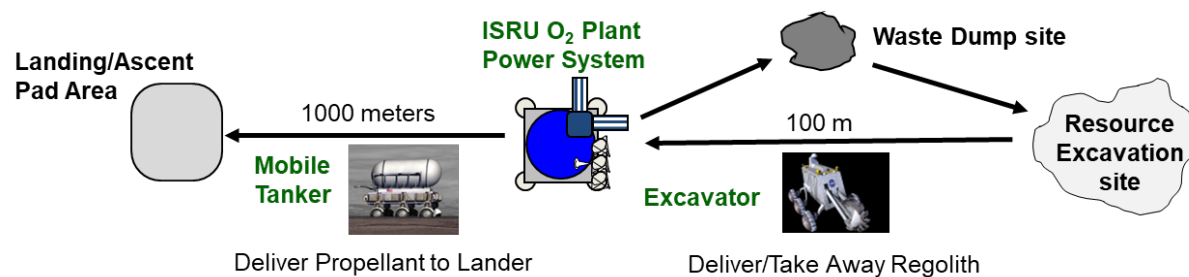
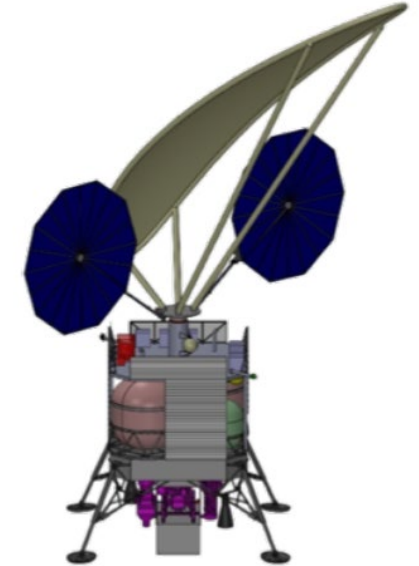

NOTE: Only one Excavator and ISRU System is shown

# Comparison: Water to O<sub>2</sub> from Regolith Commissioning (first use)

## Mass

- The ISRU system, without the lander and bus was used for the comparison
- The O<sub>2</sub> system included solar panels for power, this mass was subtracted since the water system does not include power
- The O<sub>2</sub> system requires hydrogen from earth whereas the water system produces this. An approximation of the hydrogen mass and tank was added.

## Power

- The water system power disregards thermal versus electrical power; assumes even thermal (heating) must come from electrical source
- The O<sub>2</sub> system uses a solar concentrator to supply direct heating to the regolith for reaction.

Water Ice ISRU System		O <sub>2</sub> from Regolith ISRU System	
<b>Total Mass</b>	<b>4.9 mT</b>	<b>2.7 mT</b>	
<i>Ridge System</i>	2.6 mT	<i>ISRU system</i>	0.429 mT
<i>Mine system</i>	0.49 mT	<i>H<sub>2</sub> from earth</i>	2.3 mT
<i>2 water Tankers</i>	1.8 mT		
<b>Total power</b>	<b>68 kW</b>	<b>45 kW</b>	
<i>Ridge Power</i>	46 kW	<i>Electrical</i>	11.8 kW <sub>e</sub>
<i>Mine Power</i>	22 kW	<i>Direct thermal</i>	33.3 kW <sub>t</sub>

# Comparison to O<sub>2</sub> from Regolith Results

Water Ice	O <sub>2</sub> from Regolith
4.9 mT	2.7 mT *each successive mission will require 2 mT of hydrogen from earth, so mass favorably is lost at 2 <sup>nd</sup> mission.
68 kW	45 kW
Resource is not yet characterized, exploration is required prior to operations to determine extent.	Resource is largely known from returned.
Highly reliant on location with accessibility challenges; likely requires higher traverse distances and some operations in an extreme environment (PSR).	The resource is very accessible and ubiquitous.
This case study requires operations at two locations.	Case study does full operations at one location.
Thermal energy for resource extraction is lower; water vaporization energy.	Thermal energy for resource extraction is high, requires melting of regolith
Use of non-electrical heat sources is challenging.	The system can use direct solar thermal heating to reduce electrical power.
Provides full propellant for vehicles. Water can also be used for other applications.	Only oxygen is provided.



# ISRU Technology Synergy

Oxygen from Lunar Regolith

Polar Water Mining

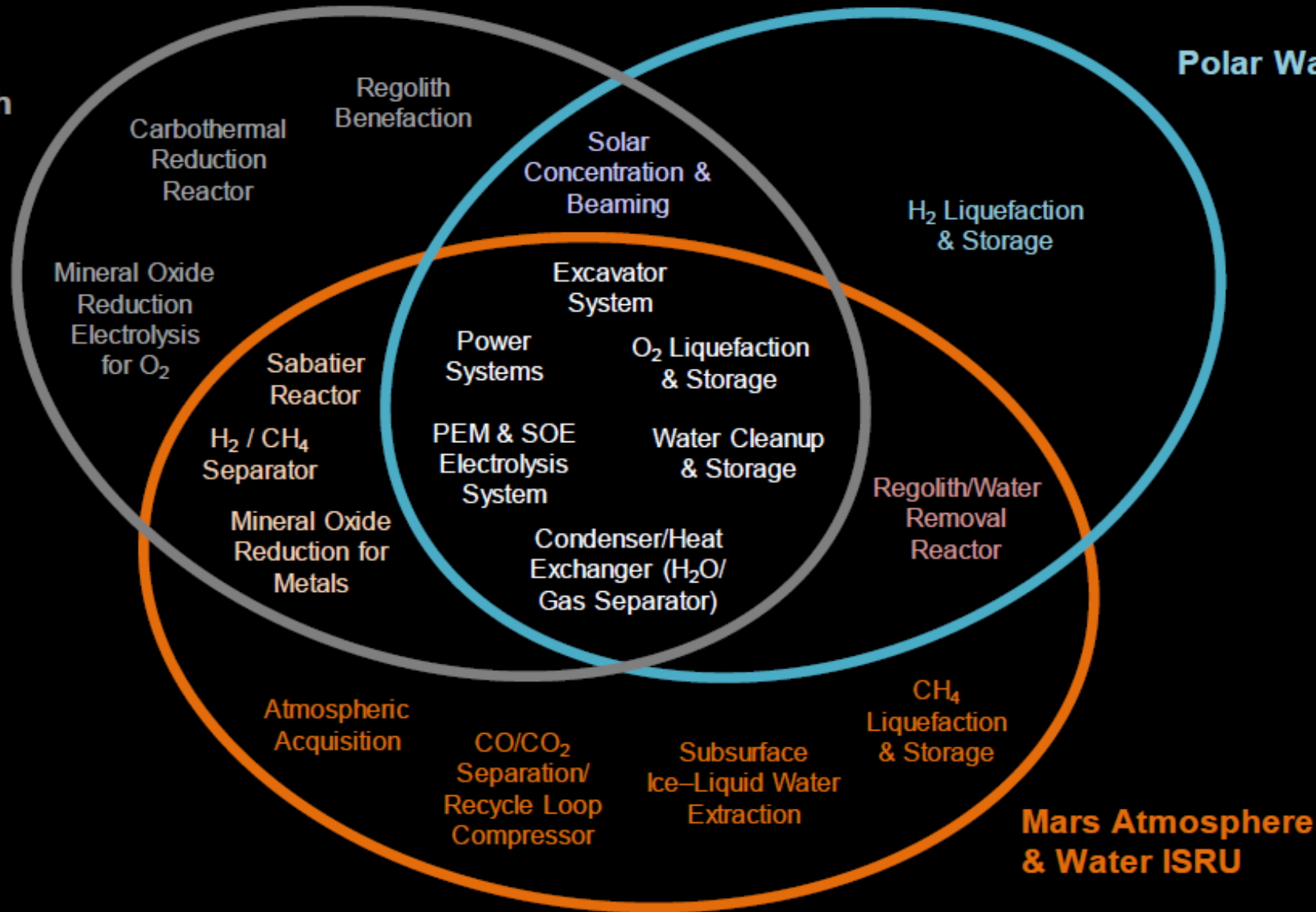

Mars Atmosphere & Water ISRU



# Gaps

Technologies that need work and knowledge that is missing...



# Summary of Key ISRU Gaps

Gap	Explanation	Resource Assess	Water Mining	Oxygen from Minerals	Excavation & Delivery	Construction
Regolith properties	Particularly at polar & PSR locations	X	X	X	X	X
Water distribution knowledge	Lateral & depth distribution and concentration	X	X			
Water form	How the water is bound, its release energy & contaminants	X	X			
Operations in extreme environments	Demonstrating performance, applicability/feasibility of technology in environment		X	X		X
Autonomous operations	Long term, extensive autonomy e.g., for mining and processing		X	X	X	X
Long duration operations	Life cycle, maintenance, regenerative technologies, long distance traverses		X	X	X	X
Power accessibility (electrical and thermal)	Power supply in extreme environments, and distributed locations		X	X	X	
Scalability	Laboratory and demonstration scale to full scale		X	X		X

# Detail of ISRU Capability Gaps (1 of 2)

## Resource Assessment Capability Gaps

- Surface features and geotechnical data on regolith outside and inside permanently shadowed craters (PSRs)
- Understanding of water and contaminants as a function of depth and areal distribution
- Understanding of subsurface water/volatile release with heating
- Resolution of hydrogen and subsurface ice at <10's m scale (or less) for economic assessment & mine planning (orbital/surface)
- Instrument for polar regolith sample heating and released volatile characterization (minimum loss during transfer/evaluation)
- Long duration operations at <100 K temperatures and lunar vacuum
- Traversability inside and in/out of PSRs
- Increased autonomy and better communications into PSRs
- Long-duration mobile polar resource assessment operations (nuclear or power beaming)



## Mining Polar Water Capability Gaps

- Limited knowledge/understanding of polar water depth, distribution, concentration to at least 1 m below the surface and multiple sq km.
- Limited knowledge/understanding of regolith properties within PSR
- Feasibility and operation of downhole ice/water vaporization and collection in cold-trap under lunar PSR conditions
- Feasibility and operation icy regolith transfer and processing in reactor under lunar PSR conditions
- Other volatile capture and separation; contaminant removal
- Water electrolysis, clean-up, and quality measurement for subsequent electrolysis or drinking (10,000's kg)
- Long-term operation under lunar PSR environmental conditions (100's of days, 10,000's kg of water)
- Electrical power & Thermal energy in PSRs for ice mining/processing (10's of KWs)

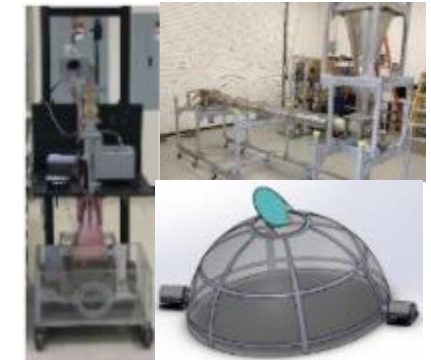

## Oxygen Extraction Capability Gaps

- Increase scale of regolith processing by 1 to 3 orders to reach minimum of 10 mT O<sub>2</sub>/yr (depending on method)
- Increase duration operation under lunar environmental conditions (100's of days, 10,000's kg of O<sub>2</sub>)
- Long-life, regolith transfer (100's mT) and low leakage regolith inlet/outlet valves (10,000's cycles)
- Deployable large scale solar collection/thermal energy transfer for regolith melting
- Regenerative oxygen clean-up for direct oxygen production (10,000's kg)
- Water electrolysis, clean-up, and quality measurement for subsequent electrolysis or drinking (10,000's kg)
- Autonomous process monitoring, including measuring mineral properties/oxygen content before and after processing

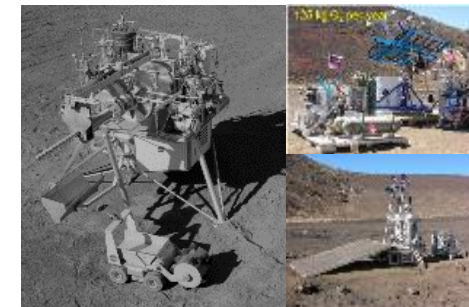

# Detail of ISRU Capability Gaps (2 of 2)

## Excavation & Delivery Capability Gap

- Excavation and sample transfer for science and ISRU demonstrations
- Excavation of hard regolith/ice material
- Long-duration operation of mechanisms
- Long-distance (100's km) travel and traversability over same mining location
- Increased autonomy of operations

CRATOS - 2008



Centaur Excavator - 2010



RASSOR



Competitions



## Surface Construction Capability Gaps

- Material and construction requirements and standards
- Long-duration operation of mechanisms; scale of construction activities
- Hardware operation and product quality under lunar environmental conditions
- Increased autonomy of operations

Grading &amp; Leveling Blade



Compactor Roller



Paver Deployment



Additive Construction



Molds - Grown





# NASA ISRU: Big Picture

Current NASA plans related to ISRU

# Artemis: Human Lunar Exploration



## Artemis Phase 1: To the Lunar Surface by 2024

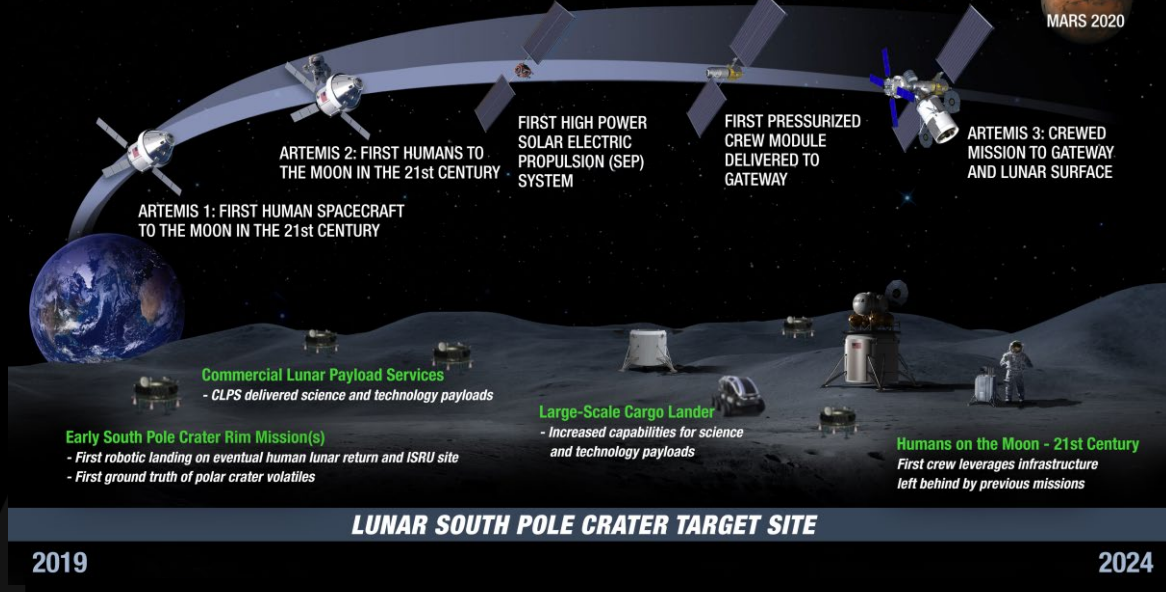

## Artemis Phase 2: Building Capabilities For Mars Missions

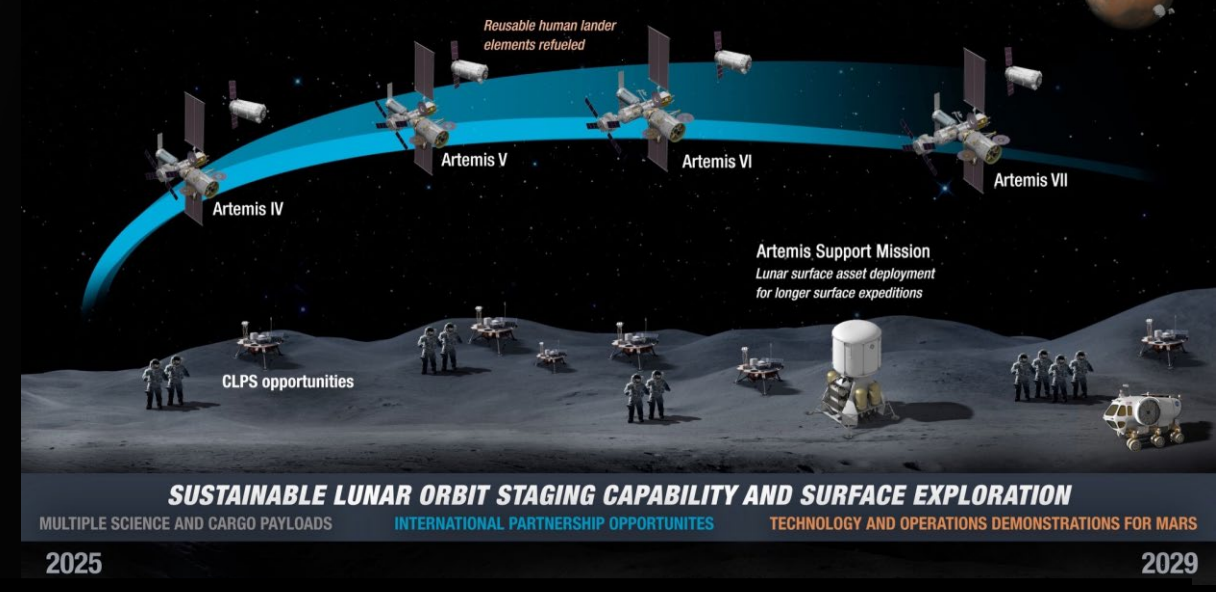

- Pre-2024 – CLPS, Robotic Science and Resource Prospecting
  - Robotic Science
  - Resource Prospecting
- 2024 (-2025) Human Lunar Surface Return
  - Unpressurized Mobility
  - EVA
  - Robotically Pre-deployed science tools and experiments
  - Non-Crewed surface mission robotic operations
    - Science, maintenance and inspection, site survey
- 2026+ Lunar Mars Mission Analogs and Long-Term Human Lunar Surface Presence
  - Pressurized Mobility
  - Offloading and deployment
  - Pilot scale ISRU
    - Demonstrate use of ISRU
  - Surface Power System
  - Habitat

**ISRU Products, Operations, and Resources Grow As Mission Needs and Infrastructure Grow**

# Lunar Surface Innovation Initiative (LSII)

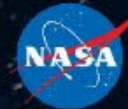

*STMD develops and performs demonstrations that allow the primary technology hurdles to be retired for a given capability at a relevant scale. While there may be additional engineering development required for scale-up, there should be none required for the foundational technologies.*

## In Situ Resource Utilization

Collection, processing, storing and use of material found or manufactured on other astronomical objects

## Surface Power

Enable continuous power throughout lunar day and night

## Extreme Access

Access, navigate, and explore surface/subsurface areas



## Surface Excavation & Construction

Enable affordable, autonomous manufacturing or construction

## Lunar Dust Mitigation

Mitigate lunar dust hazards

## Extreme Environments

Enable systems to operate through out the full range of lunar surface conditions

- Accelerate technology readiness for key lunar infrastructure capabilities enabling technology demonstrations for early un-crewed commercial missions, as well as informing development of crewed flight systems.
- Implement through a combination of in-house activities, competitive programs, and public-private partnerships.
- Coordinate with NASA's Science Mission Directorate and Human Exploration and Operations Mission Directorate to identify priorities.

# Lunar ISRU Strategy: Leader/Follower

STMD has a leader/follower path defined for lunar ISRU

- Ice mining (Leader) – Potential to provide LO<sub>2</sub>/LH<sub>2</sub> propulsion, crew consumables, and water for radiation protection
- O<sub>2</sub> from regolith (follower) – Provide oxidizer and crew consumables

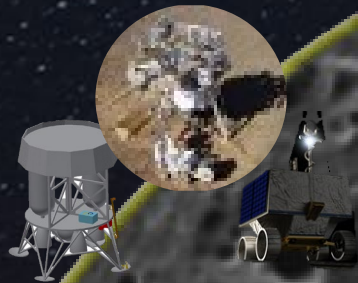

## Precursors and demonstrations

- Volatile prospecting with PRIME-1 & VIPER (2022)
- O<sub>2</sub> from Regolith high-fidelity ground demo in TVC in FY20 – 22/23

Knowledge gained from precursors and demonstrations will inform the decision for Pilot and Full-scale Plants



## Pilot Plant

- Relevant scale plant (100's of kg/yr)
- Demonstrates core capabilities and subsystems
- Products available for SMD, HEOMD, or commercial partners

# Key Questions to Address to Determine Path

## What do we need to demonstrate to relevant scale ISRU on the Lunar surface?

### Polar Water Mining Path

- Are there sufficient quantities and concentrations of accessible ice to produce desired amounts of O<sub>2</sub> and H<sub>2</sub>?
  - Access PSRs or other locations with potential ice deposits
  - Access sub-surface icy regolith
  - Assess ice concentration at multiple sites to estimate quantity
- Can lunar ice be extracted and converted into O<sub>2</sub> and H<sub>2</sub>?
  - Excavate icy regolith
  - Extract water from icy regolith
  - Assess purity and contaminants in water
  - Electrolyze water to produce O<sub>2</sub> and H<sub>2</sub>

### Oxygen from Regolith Path

- Can clean O<sub>2</sub> be produced from regolith found near the lunar poles?
  - Excavate granular material
  - Process regolith/benefaction
  - Extract Oxygen
  - Purify product

### Pilot Plant

- Can sufficient quantities propellant be produced stored?
  - Produce propellant at a rate of 100's to 1000's of kg per year
  - Liquefy all products
  - Store products for >1 year
- Can the system survive the environment?
  - Operate without crew intervention for 1-5 years
  - Survive eclipse periods
  - Operate with abrasive regolith
  - Operate in permanently shadowed region temperature environment (40 to 100 K)

# Flight Evolution & Demonstration Strategy

## ISRU - Surface Excavation and Construction



Reconnaissance, Prospecting, Sampling      Resource Acquisition & Processing      Pilot Consumable Production

*Sub-system Demonstrations: Investigate, sample, and analyze the environment for mining and utilization.*

**Oxygen Extraction Ground Demo**

**Polar Resources Ice Mining Experiment (PRIME-1)**

*Follow The Natural Resources: Demonstrations of systems for extraction and processing of raw materials for future mission consumables production and storage.*

ISRU Pilot Excavator



Lunar Surface Construction Demo 1



Lunar Surface Construction Demo (Landing Pad)

Polar Resources Ice Mining Experiment (PRIME-1)



Volatiles Investigating Polar Exploration Rover (VIPER) w/rover

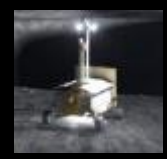

Ice-Mining Demo

Leverages VIPER design - Water extraction via heating regolith; analyze water; Measure volatiles & contaminants

O2 Extraction Demo



Lunar Auger Dryer



ISRU Pilot System for Consumable Production



Early 2020's

Mid-2020's

Late 2020's

# Lunar Science & Resource Prospecting

## Orbital Missions

Lunar Reconnaissance Orbiter



ShadowCam on Korean Pathfinder Lunar Orbiter

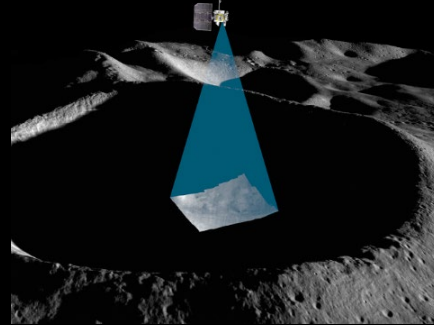

Lunar Trailblazer (Phase A)

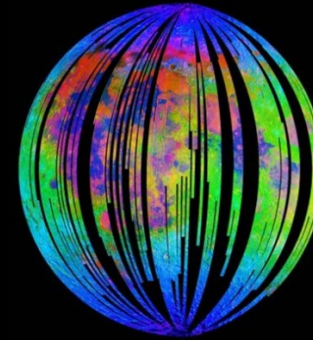

Lunar IceCube



Lunar Flashlight



LunaH-Map



## Surface Missions

Astrobotics



Intuitive Machines



Masten



PRIME-1

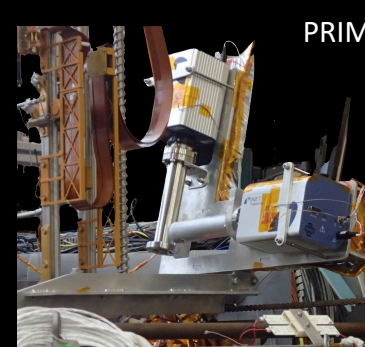

VIPER



# PRIME-1 & VIPER

First Steps toward surface understanding of Polar Water and Volatiles



## Polar Resources Ice Mining Experiment (Prime-1) on CLPS

- 2022 CLPS mounted payload to detect volatiles at 1-m depths
- Instruments include:
  - Mass Spectrometer Observing Lunar Operations (MSolo)
  - The Regolith and Ice Drill for Exploring New Terrain (TRIDENT)



## Volatiles Investigation Polar Exploration Rover (VIPER)

- 2023 at South Pole
- Measure volatiles at the lunar poles and acquire new key data on lateral and vertical distribution
  - Neutron Spectrometer System (NSS)
  - NIRVSS IR Spec
  - MSolo Mass Spec
  - TRIDENT Drill
- Build lunar resource maps for future exploration sites
  - Long duration operation (months)
  - Traverse 10's km



# NASA ISRU Technology and System Development

Previous Work – Constellation Era

# Constellation Era ISRU

- **NASA's Constellation program, in the mid 2000's, targeted a return to the moon**
  - The focus was lunar equatorial regions
  - ISRU processes were focused on oxygen extraction from minerals
- **Several field campaigns took place to demonstrate technologies as a system**
- **Development took place both in-house at NASA as well as various contracted and SBIR efforts including:**
  - Reaction (resource extraction) processes
  - Excavators and regolith handling
  - Sensors (prospecting)
  - Construction (sintering, civil engineering)
  - Thermal energy systems

## Significant advancement from 2005 to 2011

TRL increase in ETDP	At Start	At End	Delta
<b>System Level</b>			
Lunar Volatile Characterization (RESOLVE)	1	5	4
H <sub>2</sub> Reduction of Regolith	2-3	5	2-3
CH <sub>4</sub> Reduction of Regolith	2-3	5	2-3
Molten Oxide Reduction of Regolith	2	3	1
Trash Processing for Water/Methane Production	2	2-3	0-1
<b>Subsystem Level</b>			
Regolith Transfer & Handling			
Regolith Transport Into/Out of Reactor	2	5	3
Beneficiation of Lunar Regolith	2-3	2-3	0-1
Size Sorting of Lunar Regolith	2-3	2-3	0-1
Oxygen Extraction From Regolith			
H <sub>2</sub> Reduction of Regolith Reactor	3	5	2
Gas/Water Separation & Cleanup	2	4-5	2-3
CH <sub>4</sub> Reduction of Regolith Reactor	3	5	2
CH <sub>4</sub> Reduction Methanation Reactor	3-4	4-5	1-2
MOE of Regolith Anode/Cathode	1-2	3-4	2-3
MOE of Regolith Molten Mat'l Removal	1-2	3	1-2
MOE Cell and Valving	2-3	3	0-1
Water/Fuel from Trash Processing			
Trash Processing Reactor	2	2-3	0-1
In-Situ Energy Generation, Storage, and Transfer			
Solar Thermal Energy for Regolith Reduction	2	5	3

Advanced to TRL 5/6 since 2011

Advanced to TRL 4 since 2011

Technologies advanced since 2011

Technology advanced since 2011

Advanced to TRL 4 since 2011

# Lunar ISRU Development Under Constellation Program

## Excavation for O<sub>2</sub> Extraction



## Site Preparation-Area Clearing



## O<sub>2</sub> Production/Volatile Extraction from Soils



## Resource Prospecting/Mapping

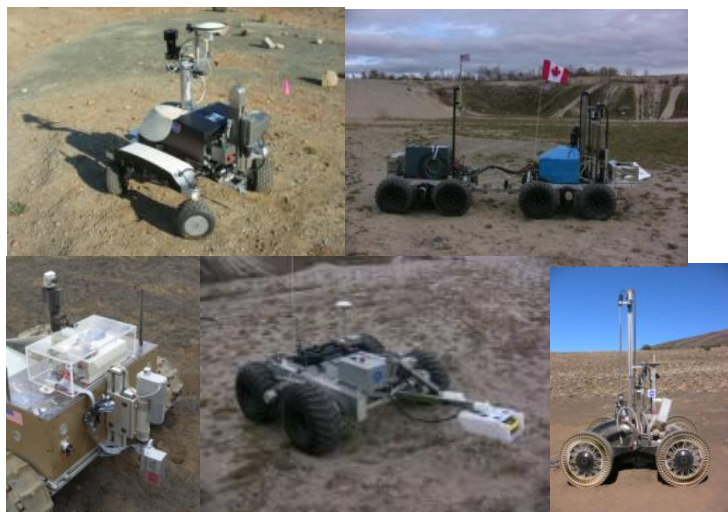

## Surface Sintering/Hardening



# Lunar Processing – Oxygen & Metal Extraction

- Over 20 processes have been identified to extract the oxygen

- Several have been evaluated in the lab to TRL 3 at subscale
- As processing temps increase, O<sub>2</sub> yield increases, and technical and engineering challenges increase

- Work during the Constellation Program focused on three processes

- Hydrogen reduction: ‘low’ temperature, low yield (1 to 5 wt%), high TRL
- Carbothermal reduction: ‘higher’ temperature, medium yield (5 to 15 wt%), medium TRL
- Molten regolith electrolysis: ‘high’ temperature, high yield (>20 wt%), low TRL

- Two processes developed to TRL 4-5 at human mission relevant scale

## Hydrogen Reduction of Regolith

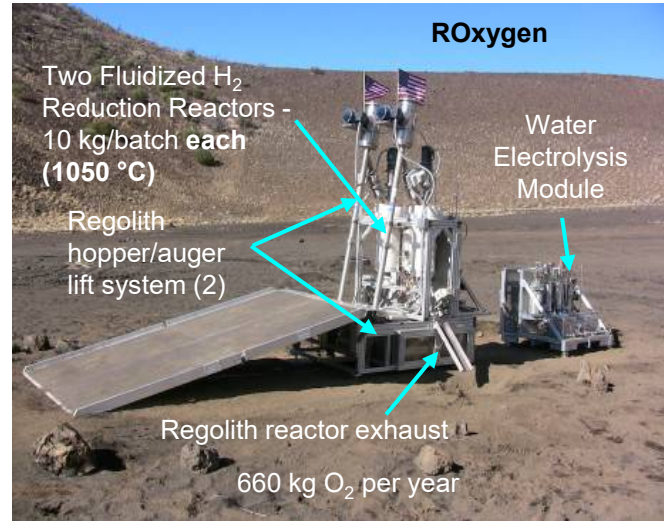

- Heat Regolith to >900 C
- React with Hydrogen to Make Water
- Crack Water to Make O<sub>2</sub>

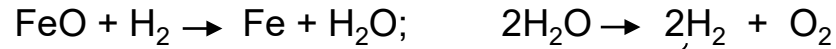
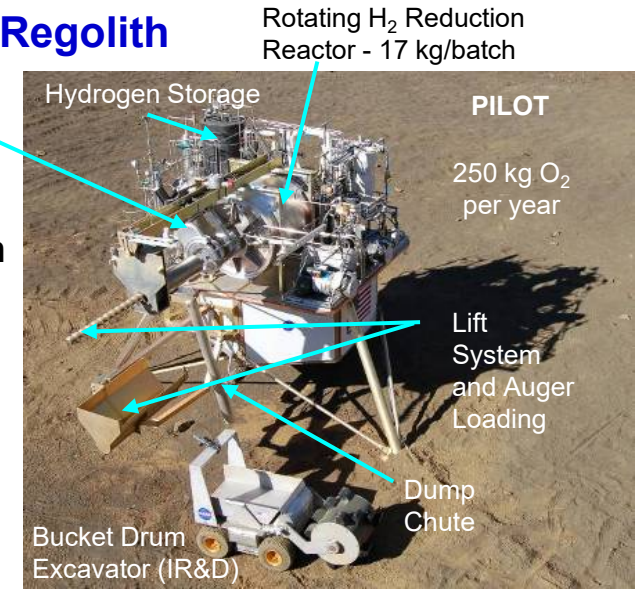

## Carbothermal Reduction of Regolith

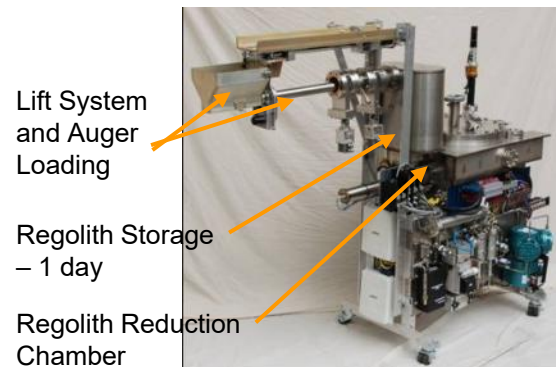

- Melt Regolith to >1600 C
- React with Methane to CO
- Convert CO to Methane & Water
- Crack Water to Make O<sub>2</sub>

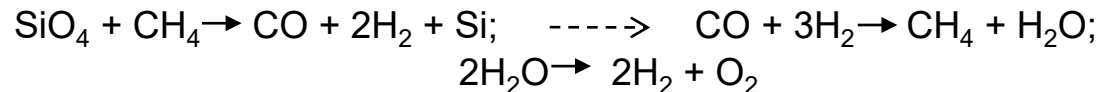

## Molten Electrolysis of Regolith

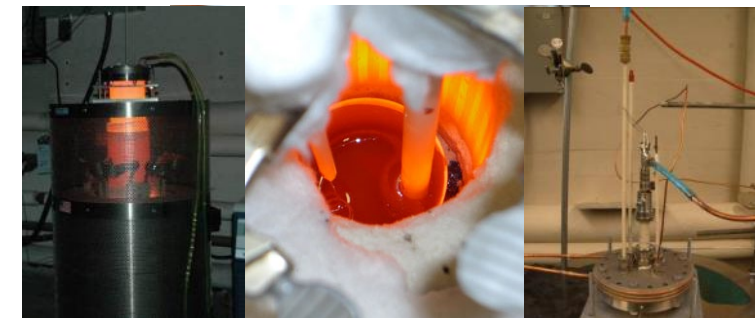

- Melt Regolith to >1600 C
- Apply Voltage to Electrodes To Release Oxygen

# Approach to Demonstrate ISRU Capabilities and Insertion into Constellation Program

- Besides developing technologies; ISRU needed to demonstrate end-to-end system capabilities
  - Utilized terrestrial analog locations to integrate and test technologies into systems in relevant terrain and surface material
- System analog tests were focused by three main drivers
  - Space Mining Cycle: Show flow from resource assessment to product delivery and infrastructure needed to enable the cycle
  - ISRU Integration with Transportation/Surface Elements: Understand interfaces and possibly common fluids
  - Technical, Programmatic, and Intrinsic Benefits: Specific goals and objectives for all three were established and evaluated

## Space Mining Cycle

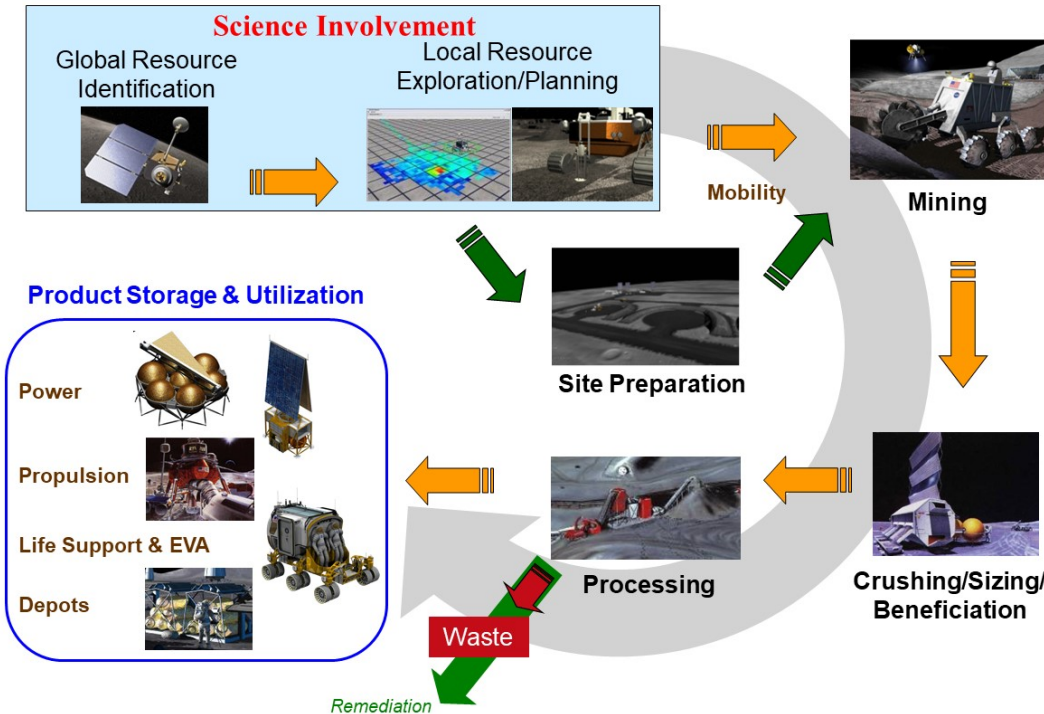

## ISRU- Transportation/Surface Element Integration

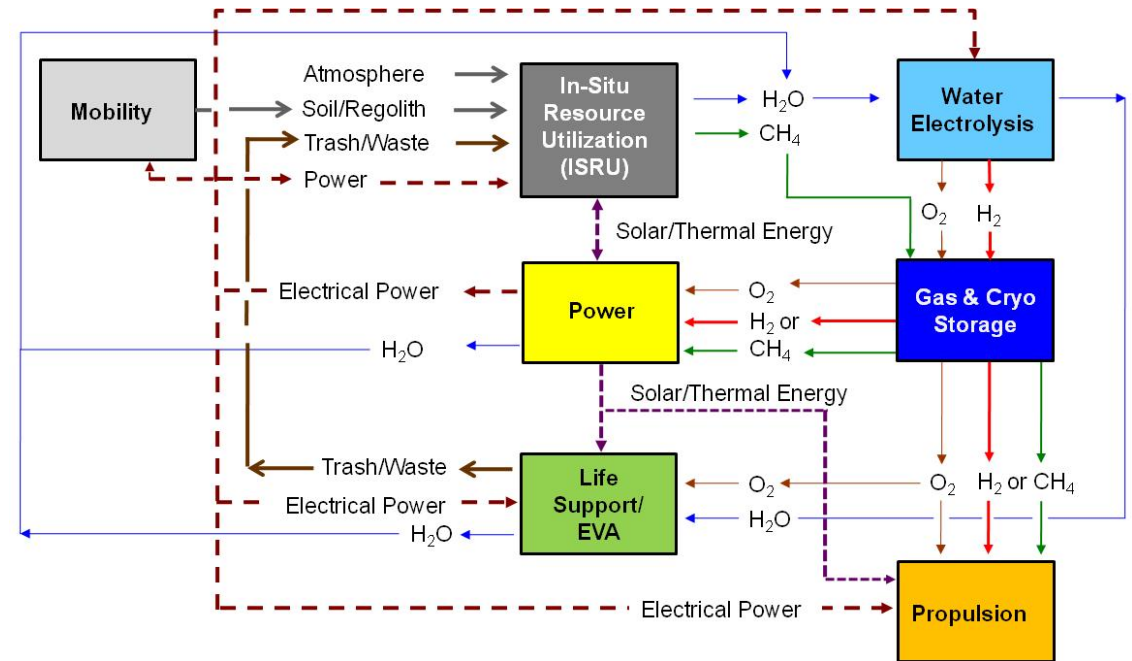

# Demonstration of Space Mining Cycle with Surface/Transportation

## 1st Demonstration of Space Mining Cycle (Hawaii Analog 2008)

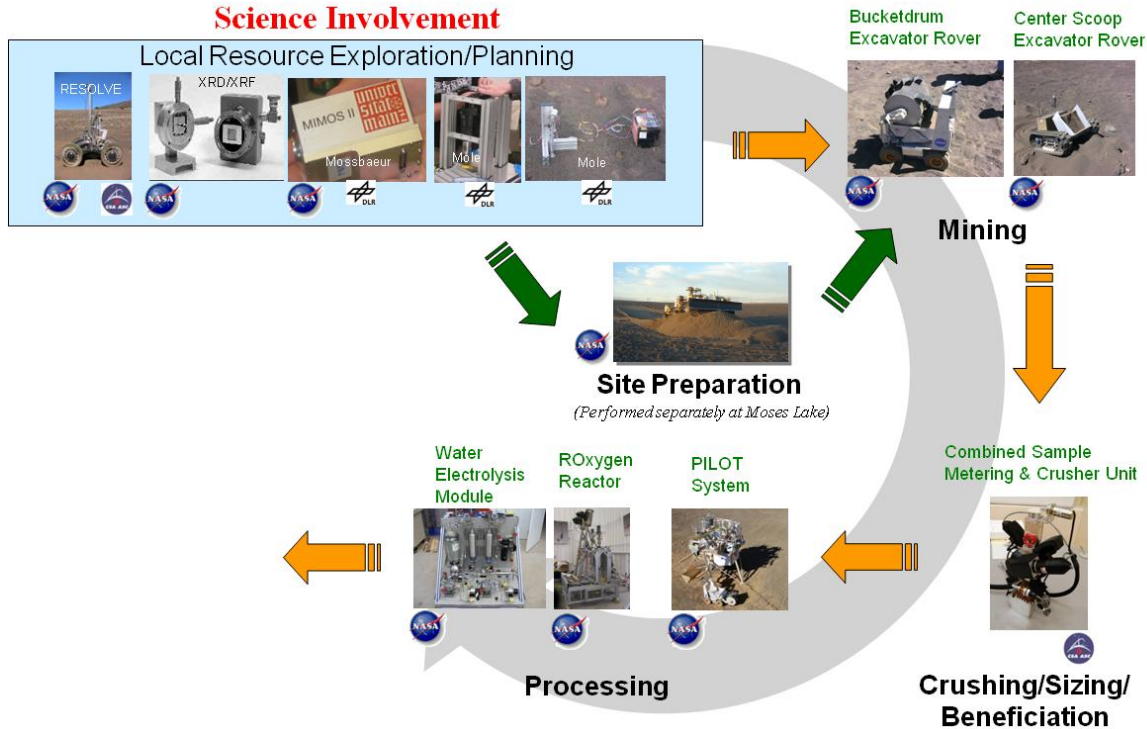

## 2nd Demonstration of Space Mining Cycle (Hawaii Analog 2010)

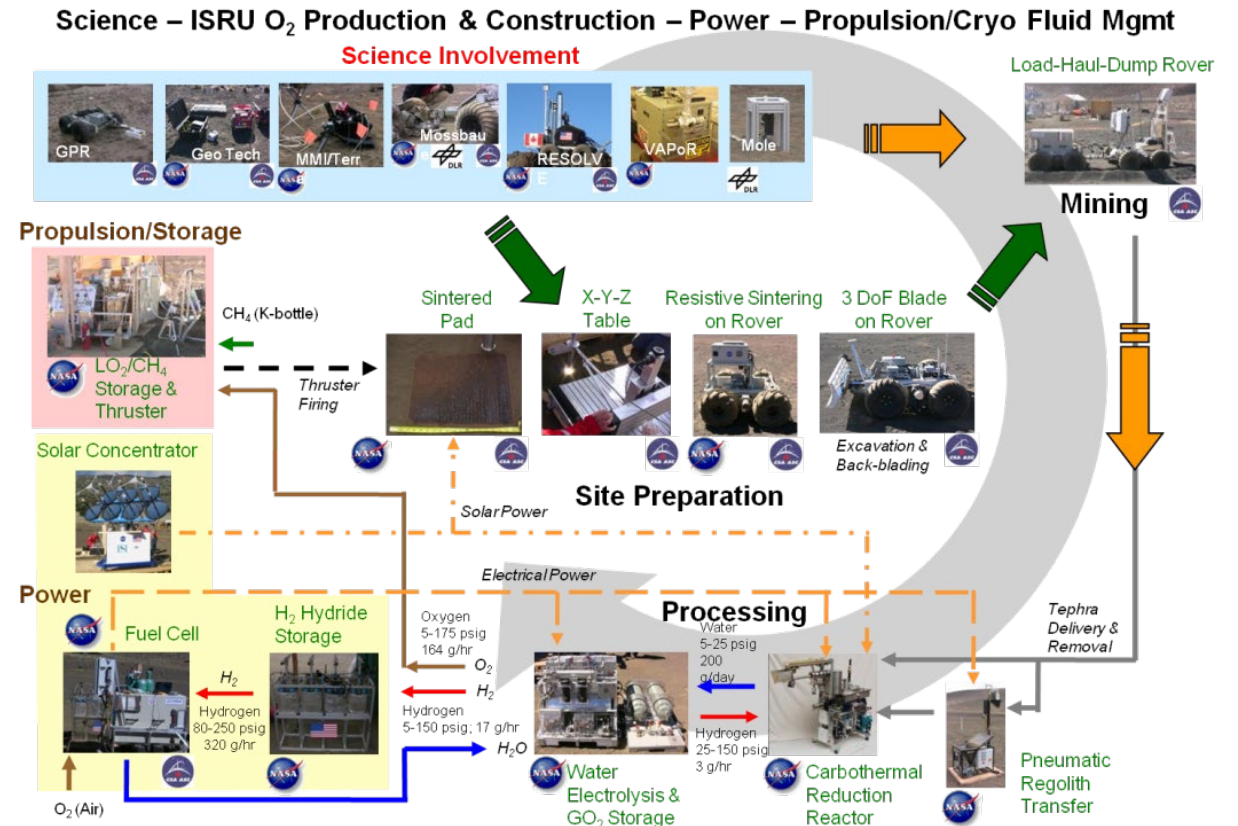

Significant advancements were made in demonstrating:

- The Space Mining Cycle and ISRU Integration with other Elements during Constellation
- International Partnerships and interfacing with mission critical roles



# NASA ISRU Technology and System Development

Current status



# Strategy For ISRU Insertion into Human Exploration

- **Know Customer Needs and Gaps**
  - Work with Artemis elements and Moon/Mars Surface Architecture
  - Work with Industry/Academia: Lunar Surface Innovation Consortium
- **Perform Ground Develop of Hardware and Systems until Flight**
  - Develop and advance ISRU technologies to enable acquisition of resources and processing into mission consumables
  - Develop lunar ISRU components and subsystems with a Mars-forward application
  - **Engage industry and Academia** to lay the foundation for long-term lunar economic development
- **Utilize CLPS Precursor Missions**
  - Understand lunar polar resources for technology development, site selection, mission planning
  - Obtain critical data (ex. regolith properties, validate feasibility of ISRU process)
  - Demonstrate proof-of-concept and reduce risk
  - Demonstrate critical ISRU hardware and validate Pilot/Full scale designs
- **Perform End-to-End ISRU Production Pilot Mission** at sufficient scale to eliminate risk of Full scale system
  - Utilize product from Pilot mission in subsequent human lander mission (ex. oxygen for EVA or extended stay)
- **Design and Fly ‘Full’ Scale ISRU Production Capability** around redundant modules with margin for reusable lander and/or hopper
- **ISRU must first be demonstrated on the Moon before it can be mission-critical**
  - STMD is breaking the ‘Catch-22’ cycle of past ISRU development priority and architecture insertion issues by developing and flying ISRU demonstrations and capabilities to the Pilot Plant phase.

# Technology Development\* (1 of 5)

## Lunar Polar Ice Resource Assessment

\*Impacts due to FY21 Appropriations in work

**Selected for CLPS**

### Acquire Icy Regolith Samples

- FLEET: Fundamental Regolith Properties Project - Bulk water stability – NASA GRC
- Characterization of Lunar Polar Volatiles for Curation and ISRU – NASA JSC
- ColdARM – JPL
- Trident Auger – Honeybee Robotics
- WRANGL3R - Water Regolith ANALysis for Grounded Lunar 3d Reconnaissance - Univ of Texas El Paso - LuSTR

### Instruments for Physical/Geotechnical Characterization

- Material Characterization while Drilling on Lunar/Martian Surface – ESI with CSM
- SPARTA – Honeybee Robotics; Cone penetrometer/shear vane (part of ColdArm)
- Microscope/Camera – JPL; (part of ColdArm)
- High TRL Rover Lidar – NASA GSFC
- Moon-Mars Ice Challenge – NASA LaRC
- Percussive Hot Cone Penetrometer and GPR – Mich Tech - LuSTR

### Instruments for Mineral Characterization

- Fundamental Regolith Properties Project - Bulk water stability – NASA GRC
- Recent SMD & CLPS Selections

### Instruments for Ice/Volatile Characterization

- Polar Resources Ice Mining Experiment-1 – NASA KSC & Honeybee Robotics
- Light Water Analysis & Volatile Extraction (Light WAVE) – NASA JSC
- Planetary Volatile Extractor (PVEx) – Honeybee Robotics (past SBIR)

### Mobility and Instruments for Resource Assessment

- L-Puffer/CADRE – JPL; Mini-rover w/ TBD instruments
- MoonRanger – SMD DALI; Mini-rover w/ camera (2022)
- NeuRover – SBIR Phase II; Mini-rover w/ neutron spectrometer
- Robotic Technologies Enabling the Exploration of Lunar Pits – Phase III Carnegie Mellon
- Mobile Autonomous Prospecting Platform – Lunar Outpost

Astrobotic 2021  
Massten 2022 (SP)  
Firefly 2023  
IM Prime-1 2022 (SP)  
Ast. VIPER 2023 (SP)

X

X

X

X

X

X

X

X

X

X

X

X

X

IM Prime-1 2022 (SP)  
Ast. VIPER 2023 (SP)

X

X

X

X

X

#### Mineral Characterization

NIRVSS - InfraRed Spec  
L-CIRiS - Compact InfraRed Imaging System  
eXTraterrestrial Regolith Analyzer for Lunar Soil - XRD/XRF  
Ultra-Compact Imaging Spectrometer - Shortwave IR  
BECA - Gamma Ray Spectrometer w/ Pulsed Neutrons

#### Volatile - Direct Measurement

MSolo - Mass Spectrometer  
PITMS - Ion-trap Mass Spectrometer  
CRATER - Laser-based Mass Spectrometer

#### Hydrogen Measurement

NSS - Neutron Spectrometer  
NMLS - Neutron Measurement at the Lunar Surface  
NIRVSS -InfraRed Spec (surface and bound H<sub>2</sub>O/OH)

#### Imager

Heimdall - Digital Video Recorder/4 Cameras

#### Physical Properties/Acquisition

LISTER - Heatflow Probe  
Electrodynamic Dust Shield (EDS)  
PlanetVac - Pneumatic Transfer  
SAMPLR - Arm Scoop  
ColdARM - Arm Scoop  
Trident - Auger Drill  
PVEx - Coring Drill

#### MicroRovers

CubeRover (SBIR)  
MoonRanger (LSIPT)  
L-PUFFER/CADRE (JPL)  
NeuRover (SBIR)

# Technology Development\* (2 of 5)

## Lunar Ice Mining

*\*Impacts due to FY21 Appropriations in work*

- **Demonstrate feasibility and operation icy regolith transfer and processing in reactor under lunar PSR conditions**
  - Fundamental Regolith Properties Project - Bulk water stability – NASA GRC
  - Characterization of Lunar Polar Volatiles for Curation and ISRU – NASA JSC
  - Material Characterization while Drilling on Lunar/Martian Surface – ESI with Colorado School of Mines (CSM)
  - Lunar Auger Dryer (LADI) with inlet/outlet – NASA JSC
  - Regolith Valve project – NASA GRC
  - Motors for Dusty Environments/Bulk Metallic Glass Gears
  - Aqua Factorem-Ice Crystal Sifting – UCF NIAC Phase I
- **Demonstrate feasibility and operation of downhole ice/water vaporization and collection in cold-trap in the lunar PSR**
  - PVEx: Coring drill with cryo capture – Honeybee Robotics (*past SBIRs*)
  - Thermal Management System for Lunar Ice Miners – SBIR Phase I w/ Advanced Cooling Tech tied to PVEx/Honeybee
  - LPMO: subsurface heating & volatile removal via microwave/RF/IR energy – TransAstra NIAC Phase II
  - Thermal Mining: subsurface heating & volatile removal via solar energy – CSM NIAC Phase I (Completed)
- **Water capture, clean-up, quality measurement and electrolysis (10,000's kg/yr)**
  - Lunar water simulant definition – CIF and Simulant Project
  - IHOP PEM Water Electrolysis/Clean-up – Paragon BAA
  - Solid Oxide Electrolysis: 3 contracts with OxEon (SBIR Phase II, BAA, and TP)
  - Dirty Water Alkaline Electrolysis – Teledyne BAA
  - Regenerative Fuel Cell Project – GRC
  - Lunar Propellant Production Plant (LP3) – Skyre TP
  - Integrating Thermal Processing of Lunar Ice and Solid Oxide Electrolysis for LH<sub>2</sub>/LO<sub>2</sub> Production – CSM/OxEon TP
  - Advance Alkaline Reversible Cell/Dirty Water – pH Matter TP and ACO

# Technology Development\* (3 of 5)

## Oxygen and Metal Extraction

*\*Impacts due to FY21 Appropriations in work*

- **Increase scale of regolith processing by 1 to 3 orders; Increase duration operations in lunar environmental**
  - Carbothermal Reduction reactor, feed/removal system, and reactant control – SNC, JSC, GRC with TP & 2 SBIR Phase III
  - Molten Regolith Electrolysis – KSC GCD & ECI; 2 SBIR Phase I – Lunar Resources
  - Ionic Liquid Reduction and Electrolysis reactors for O<sub>2</sub>/metals – MSFC CIF/PPBE22 and SBIR Phase I Faraday Technology
  - Plasma Hydrogen Reduction reactor and reactant control – KSC CIF and PPBE22
  - CO/H<sub>2</sub> Reduction and Metal formulation - SBIR Phase II Sequential with Pioneer Astronautics
  - Carbothermal/Vapor Pyrolysis with Solar Concentrator – SBIR Phase I with Outward
- **Long-life, regolith transfer (100's mT) and low leakage regolith inlet/outlet valves (10,000's cycles)**
  - Fundamental Regolith Properties project – regolith sealing and vibratory regolith transfer – NASA GRC
  - Regolith Valve – NASA GRC
  - Dev of Dust-Tolerant Seals & Performance Database - NASA
- **Deployable large scale solar collection/thermal energy transfer for regolith melting**
  - Multi-dish concentrator w/ fiber optic delivery – PSI SBIR Phase II.
  - Inflatable solar concentrator and mirror/lens assembly – for APIS NIAC Phase II
- **Reactant/Product Separation, Regeneration, and Recycling**
  - Helium and Hydrogen Mixed Gas Separator – SBIR with Skyhaven
  - Methane/Hydrogen Microchannel Separator – BAA with Skyhaven
- **Autonomous process monitoring, including measuring mineral properties/oxygen content before and after processing**
  - Laser Spectrometers for Impurity Analysis in ISRU Gas Streams - JPL
- **Water capture, clean-up, quality measurement and electrolysis (10,000's kg/yr)**
  - *See Lunar Polar Ice Mining – Technology Development by Function*

# Technology Development\* (4 of 5)

## Excavation and Delivery

*\*Impacts due to FY21 Appropriations in work*

- **Excavation and Sample Transfer for Science and ISRU Demonstrations**
  - PlanetVac: pneumatic transfer
  - SAMPLR: Arm/scoop
  - COLDArm: Arm/scoop with instruments
- **Excavation of Hard Regolith/Ice material**
  - Fundamental Regolith Properties Project – regolith/excavation forces
  - Motors for dusty & extremely cold environments; BMG Gears and Motors
  - Lunar Ice Mining Using a Heat-Assisted Cutting Tool – SBIR Phase I w/ Sierra Lobo
  - NASA LSII RASSOR Bucket Drum Design GrabCAD Challenge
  - Break the Ice Centennial Challenge (Soon to be released)
- **Excavation and Delivery of Regolith:** Long-duration operation (100's days) of mechanisms with abrasive regolith and lunar environmental conditions (esp. PSR conditions)
  - Fundamental Regolith Properties Project – regolith/excavation forces
  - Motors for dusty & extremely cold environments; BMG Gears and Motors
  - ISRU Pilot Excavator (RASSOR) to flight prototype
  - Build and Excavation Autonomous System with Transportation BEAST

# Technology Development\* (5 of 5)

## Surface Construction

*\*Impacts due to FY21 Appropriations in work*

- **Surface Construction Materials**
  - Developing a Material Response Model of Biopolymer Stabilized Regolith to Predict Micrometeoroid Damage of ISRU Habitat Systems – STRG with Stanford Univ.
  - Lattice Reinforced Regolith Concrete for Lunar Infrastructure – NASA MSFC
  - In Situ Lunar Launch and Landing Pad Construction with Regolith and Thermoset Polymers – NASA KSC
  - Regolith size sorting and mineral beneficiation - SBIR Phase II Sequential with Pioneer Astronautics
  - Regolith size sorting - SBIR Phase I with Grainflow (not selected for Phase II)
  
- **Surface Construction Techniques and Applications**
  - ISM-Moon-to-Mars Planetary Autonomous Construction Technology (MMPACT) – NASA MSFC
  - In Situ Construction – NASA KSC
  - Lunar Safe Haven Seedling Study – NASA LaRC
  - Additive Construction System for Lunar ISRU Applications – ACO AI Space Factory & KSC
  - Concentrated Solar Regolith Additive Manufacturing – STRG with CSM
  - Collaborative Manipulation for Space Exploration and Construction – STRG with Stanford Univ.
  - Scalable Cellular Infrastructure Technology – NASA

# University & Public Involvement ISRU & Construction Related Challenges



## Printed 3D Habitat Challenge

- Design, build habitat elements, and 3D print a subscale habitat
- Phase III completed 2019

## CO<sub>2</sub> Conversion Challenge

- Convert CO<sub>2</sub> into sugars
- Phase I completed
- Phase II launched Sept 2019

## Watts on the Moon Challenge

- Solutions for energy distribution, management, and/or storage
- Launched Sept. 2020

## Break the Ice Challenge

- Excavate icy regolith in PSR
- Phase I launched Nov. 2020



## Lunar PSR Challenge 2020

- completed Jan. 2021
- Exploration of PSR regions
- Technologies to support ISRU in PSRs
- Capabilities to explore & operate in PSRs

## Lunar PSR Challenge Results

- 8 university teams; mobility, power beaming, tether, and wireless charging, instrument, and tower
- Winner: MTU superconducting cable deployment

## Lunar Dust Challenge 2021 – launched Sept. 2020

- Landing Dust Prevention and Mitigation
- Spacesuit Dust Tolerance and Mitigation
- External Dust Prevention, Tolerance and Mitigation
- Cabin Dust Tolerance and Mitigation

## Moon Mars Ice Challenge

- Yearly, university, started in 2017 for Mars ice; added Moon in 2019
- Understand subsurface stratigraphy/hardness
- Extract subsurface water
- 10 teams compete in final 2 day event at LaRC

## Lunabotics Robotic Mining Competition

- Yearly, university, started in 2007 following Lunar Excavation Centennial challenge
- Design and build robotic machines to excavate simulated lunar soil (in 30 min.)
- Teams compete at KSC

## ISRU NASA Solicitation Opportunities

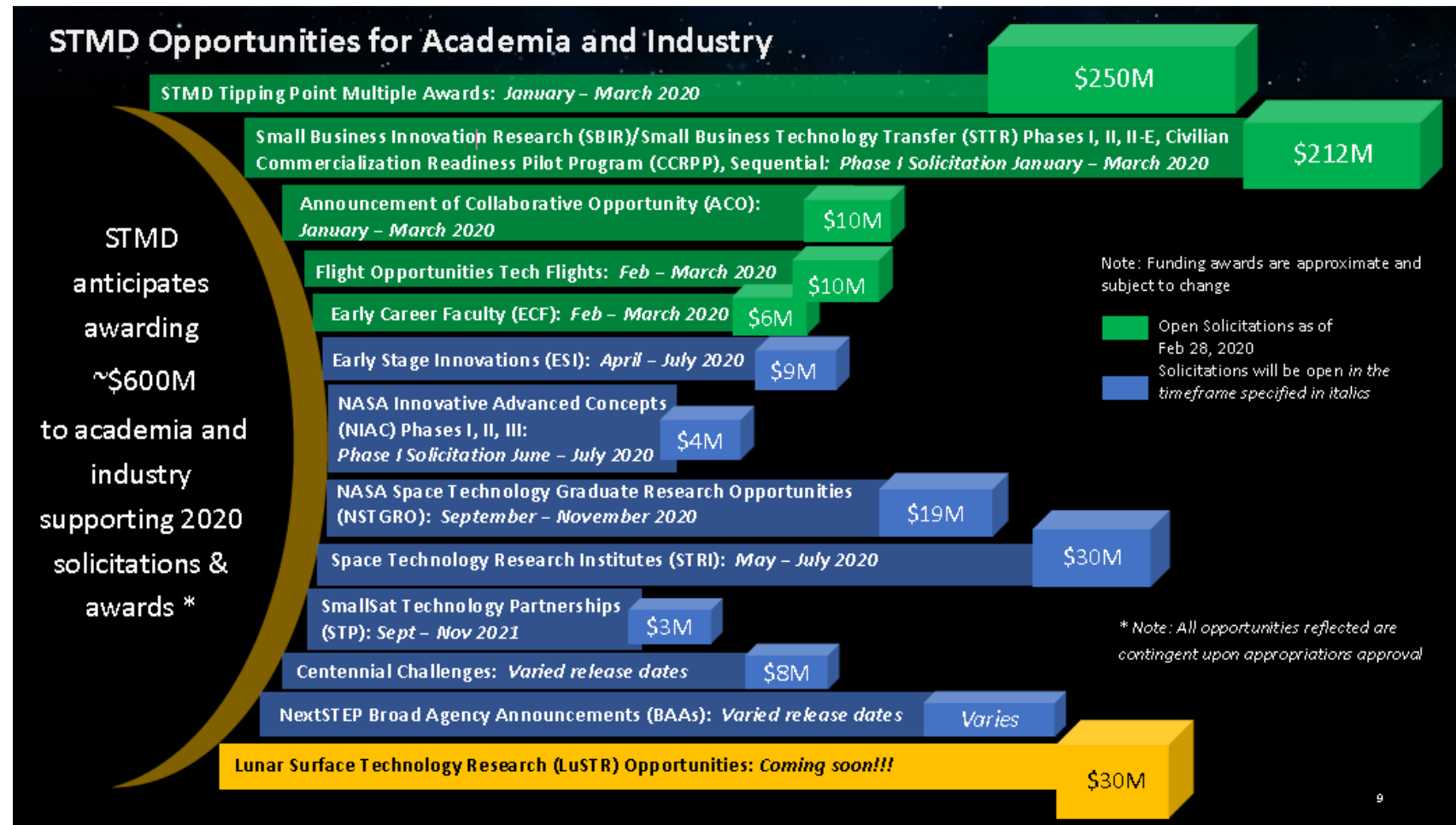

- NASA internal solicitation/competitions through PPBE and CIF activities
- Resource Assessment instruments also covered in multiple SMD solicitations: NPLP, LSITP, DALI, PRISM