

# **Aerodynamic Modeling for EDL**

## ***Briefing to Summer Students and the NESC Academy***

July 21, 2021

**Karen Bibb**

Aerothermodynamics Branch, LaRC

Orion Crew Module Aerodatabase Technical  
Lead

# How did I end up studying Aerothermodynamics?



Sailing → Aerodynamics

→ Aerospace Engineering  
→ Combustion

→ Aerothermodynamics

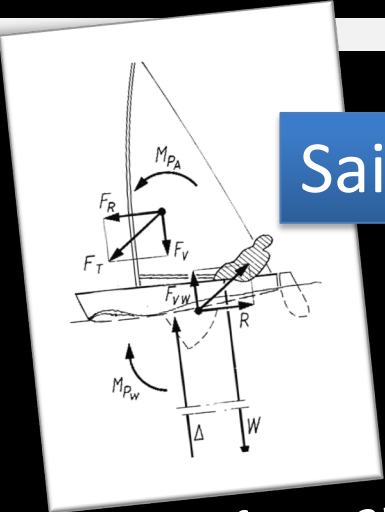

My first force and moment diagram

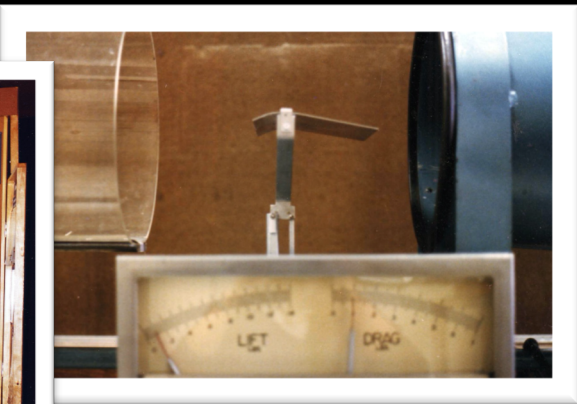
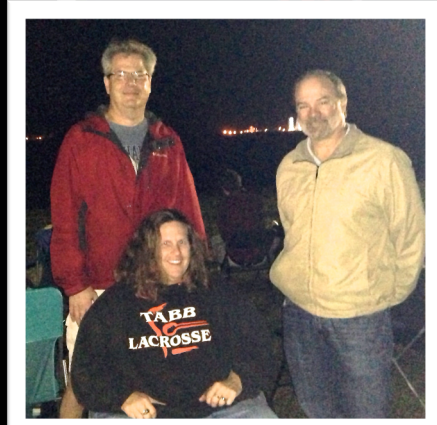

Sail Aerodynamics for High School Science Fairs

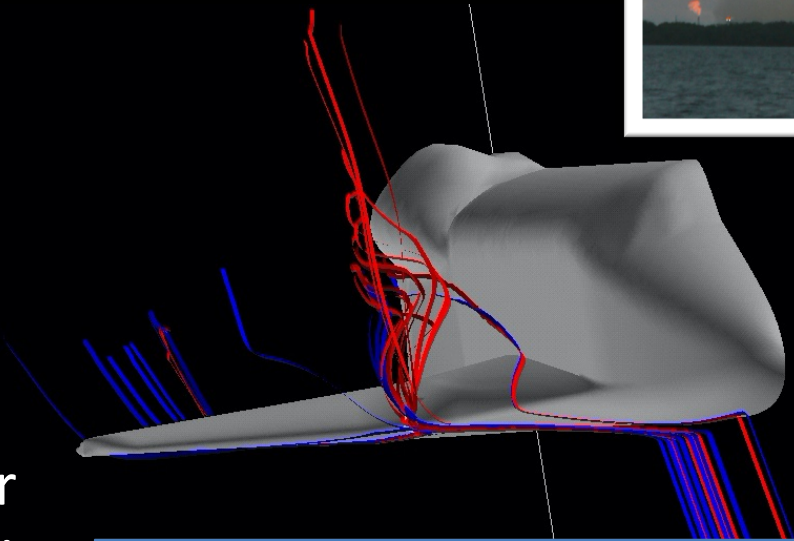

# Aerodynamics is...



## aer·o·dy·nam·ics

/,erō,dī'namiks/

*noun*

the study of the properties of moving air and the interaction between the air and solid bodies moving through it.

- the properties of a solid object regarding the manner in which air flows around it.  
plural noun: **aerodynamics**  
"the plane has the aerodynamics of a brick once the forward thrust is lost"

Definitions from Oxford Languages

*Feedback*

## What are we covering today?

- How is aerodynamic modeling used in EDL?
- How do we develop aerodynamic predictions?
- How do we communicate aerodynamics to the rest of the EDL disciplines?

# Aerodynamics in Entry, Descent, and Landing



## EDL aero is an iterative process

- Start with low fidelity, high uncertainty
- Increase fidelity of analysis, configuration
  - Enable missions
  - Lower uncertainty, risk

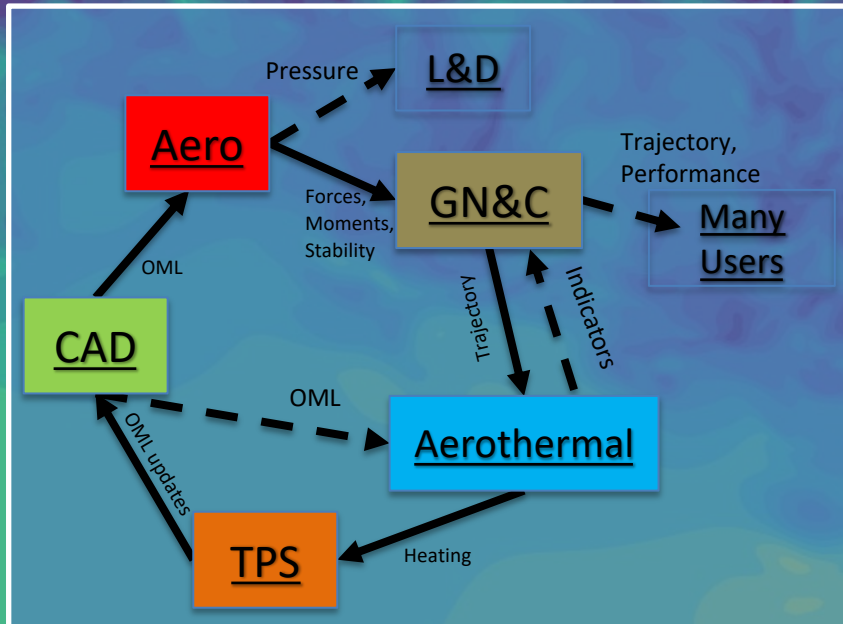

## Proper characterization of vehicle aerodynamics is critical to EDL

- Large uncertainties / too conservative can keep a design from closing, add to propellant weight, overestimate risk (too many tumbles)
- Not conservative enough leads to vehicle operating outside its design and associated failures.

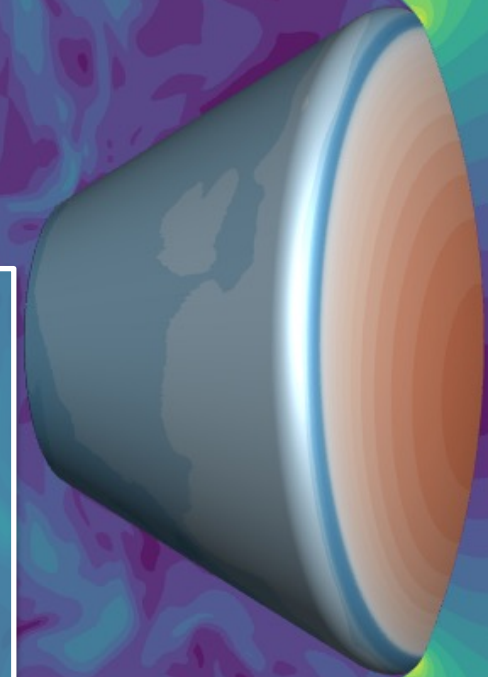

Orion capsule, subsonic, FUN3D DES  
Karen Bibb

# EDL Aerodynamics



**Understand the mission**

- Configuration
- Mission phases
- Key parameters for each phase

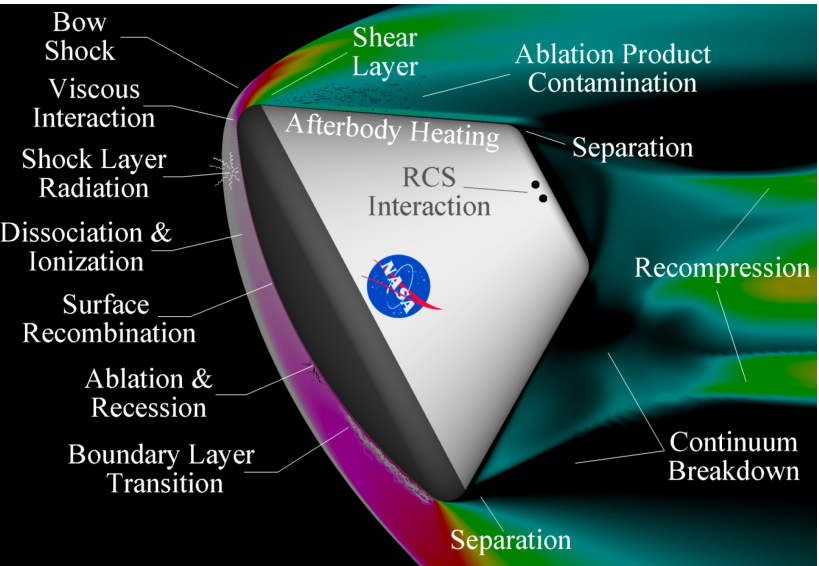
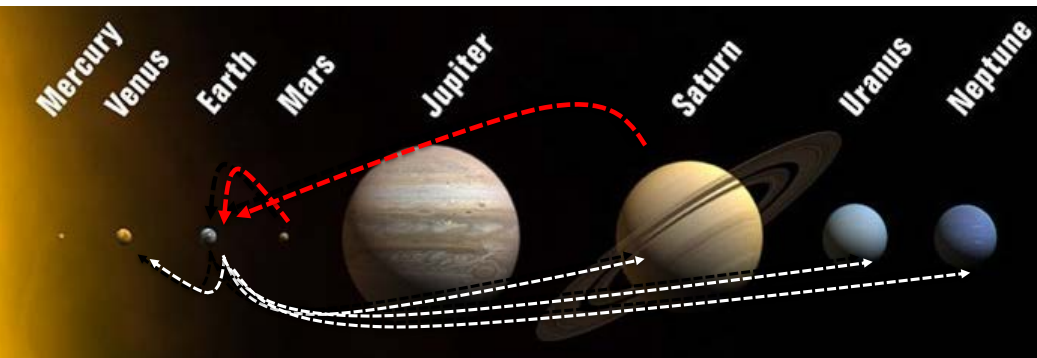

**Understand the physics**

- Basic important parameters
- Mission-specific complexities

**Understand your analysis tools**

- Range of applicability
- Accuracy/Uncertainty
- Resource requirements

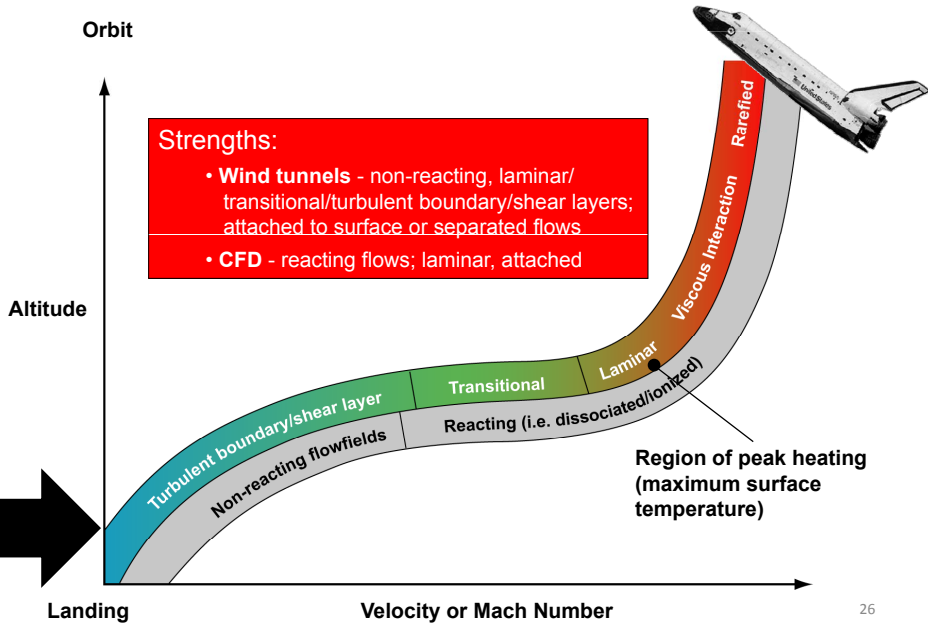

# Missions



## Augmented deceleration systems in development:

- Deployables: HIADs, ballutes, ADEPT
- Propulsive Descent – SRP
- Aerobraking/ Aerocapture

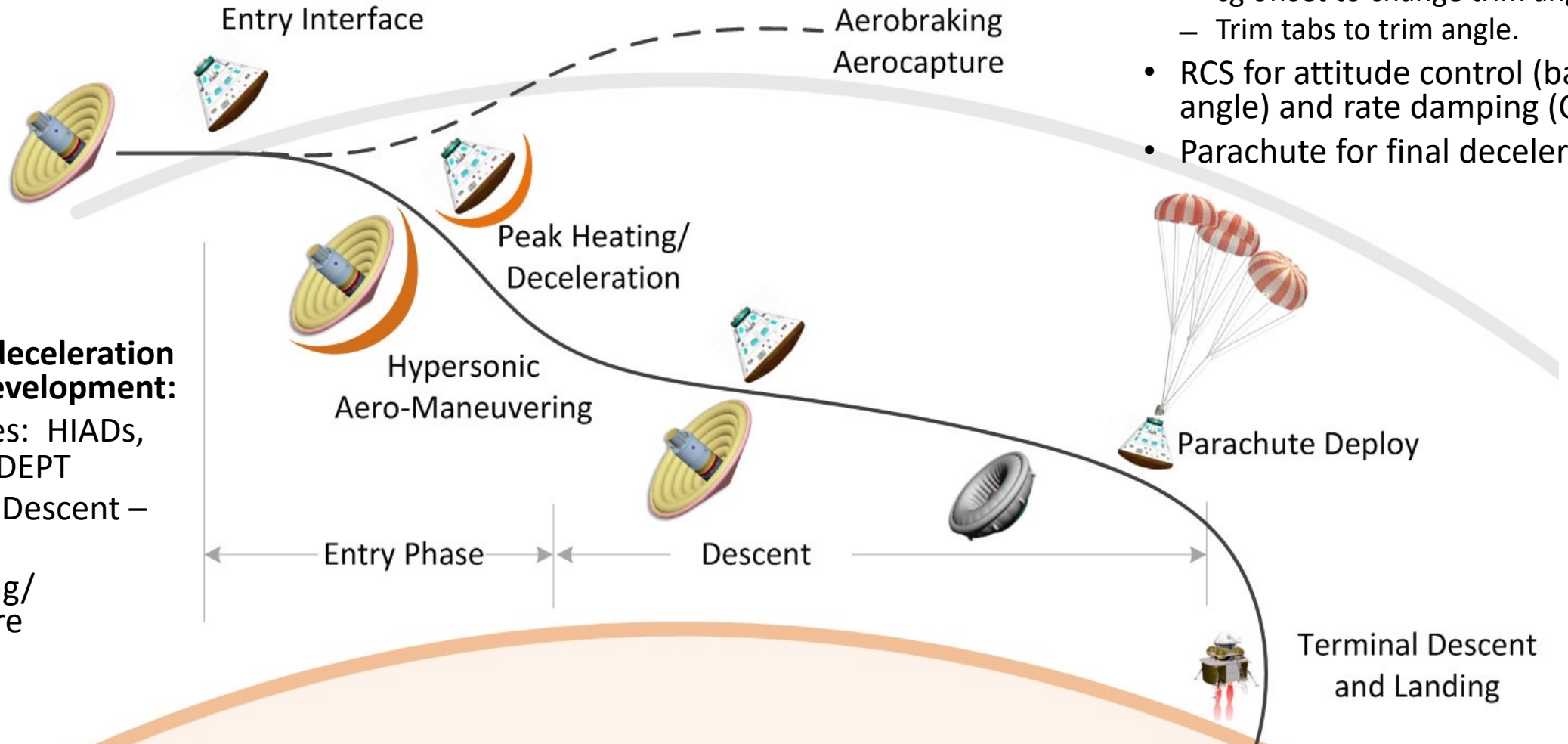

## Basic capsule entry:

- Aerodynamic deceleration ( $C_D$ )
- L/D for range control
  - cg offset to change trim angle
  - Trim tabs to trim angle.
- RCS for attitude control (bank angle) and rate damping ( $C_m q$ )
- Parachute for final deceleration

# Entry Physics and Tools



## Understand the physics

- Rarefied
- Hypersonic
- Supersonic
- Transonic
- Subsonic

## Understand your analysis tools

- Computational
- Ground Based
- Flight

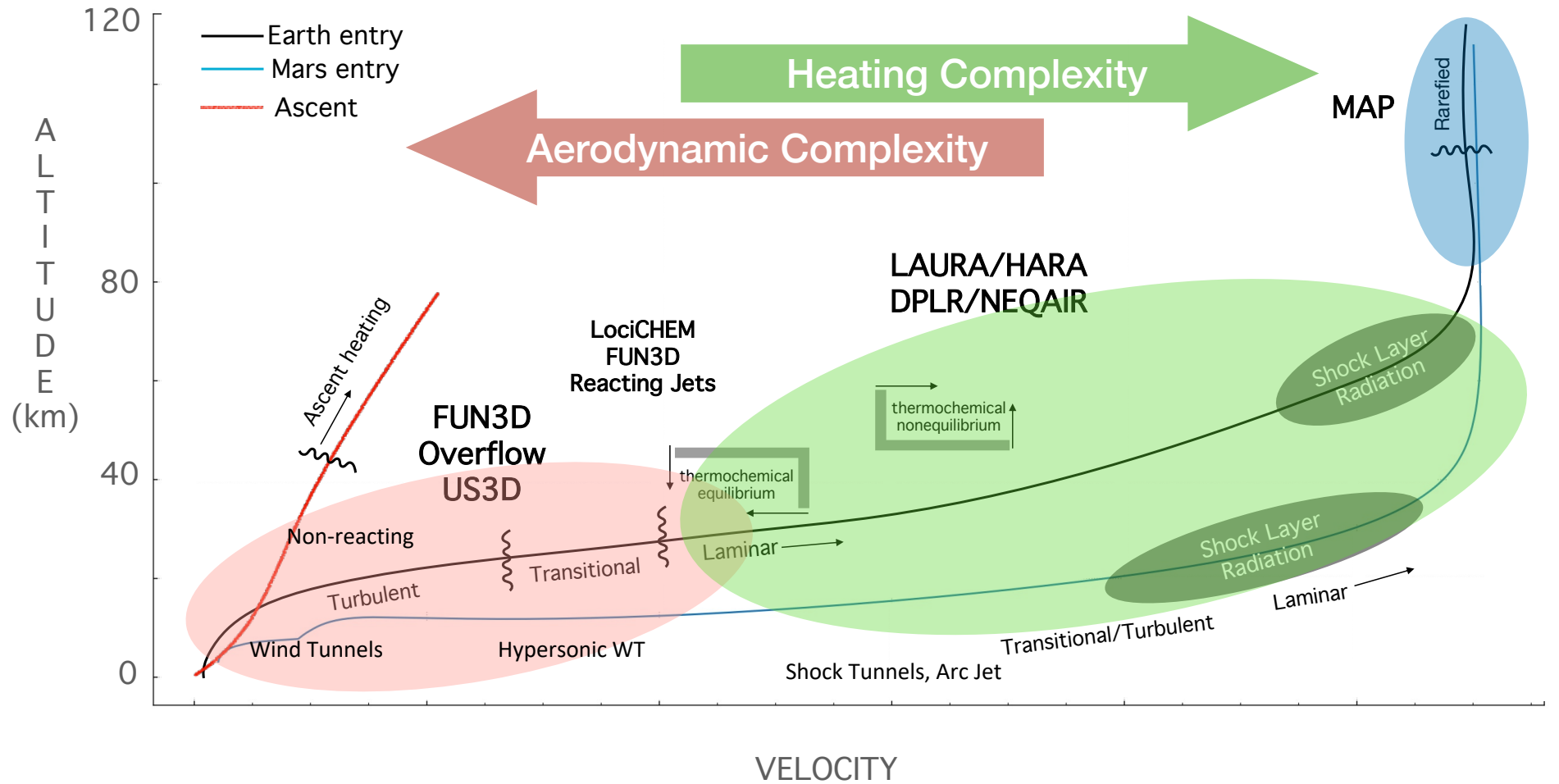

# Entry Physics and Tools



## Understand the physics

- Basic important parameters
  - Drag, particularly subsonic
  - L/D, trim angle
  - Dynamic stability (particularly under chutes)
- Mission-specific complexities
  - Orion: Large range of trajectories possible, abort and entry conditions differ
  - LOFTID: HIAD flexible structure
- Accuracy/Uncertainty
  - Subsonic drag is very difficult. Need WT for baseline

## Understand your analysis tools

- Flight can validate database, but too limited in range to fully develop database
- Flight Reynolds number testing for subsonic is necessary
- Overflow is the (Orion) workhorse for  $M < 8$ 
  - Difficult to match experiment for subsonic drag
  - DES has been too expensive in the past; we are closer to using it on a larger scale
  - Beginning to use unstructured tools (FUN3D, US3D)
- Aerothermal CFD is sufficient for  $M > 6$ 
  - CART3D for increments

## Data Sources and Mission Space Orion Crew Module Database

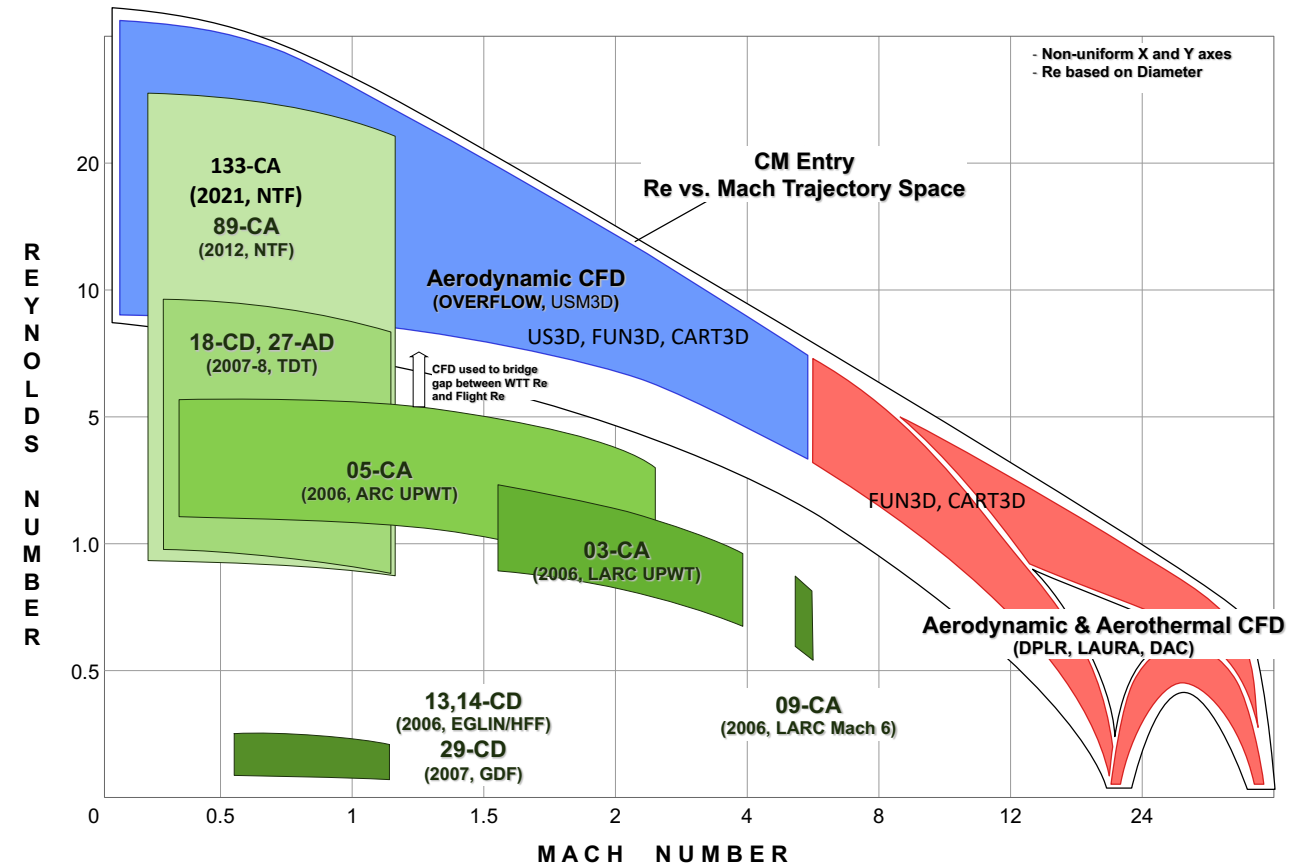

# Analysis to Customers - Aerodatabase



*The aerodatabase is how we communicate vehicle aerodynamics to customers*

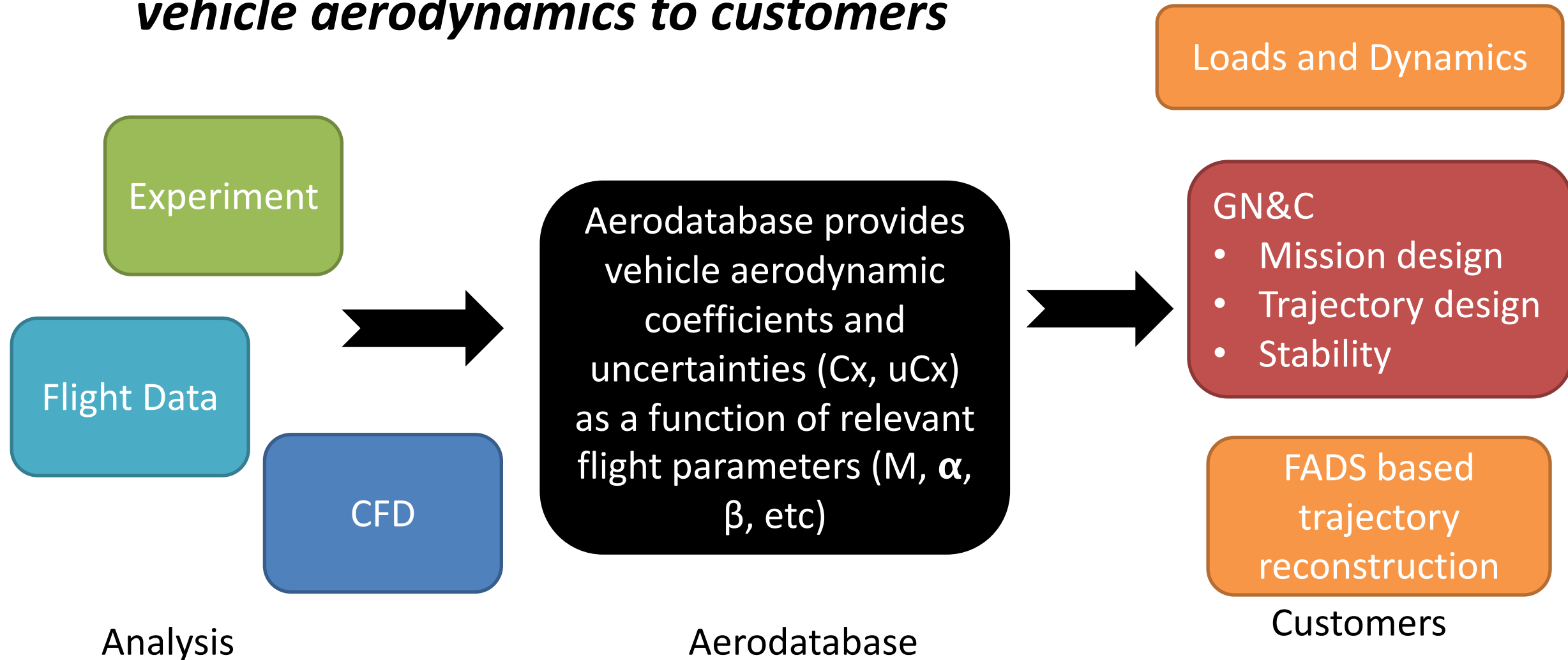

Static, dynamic, rarefied, hypersonic,  
supersonic, transonic, subsonic

# BASIC CAPSULE AERO

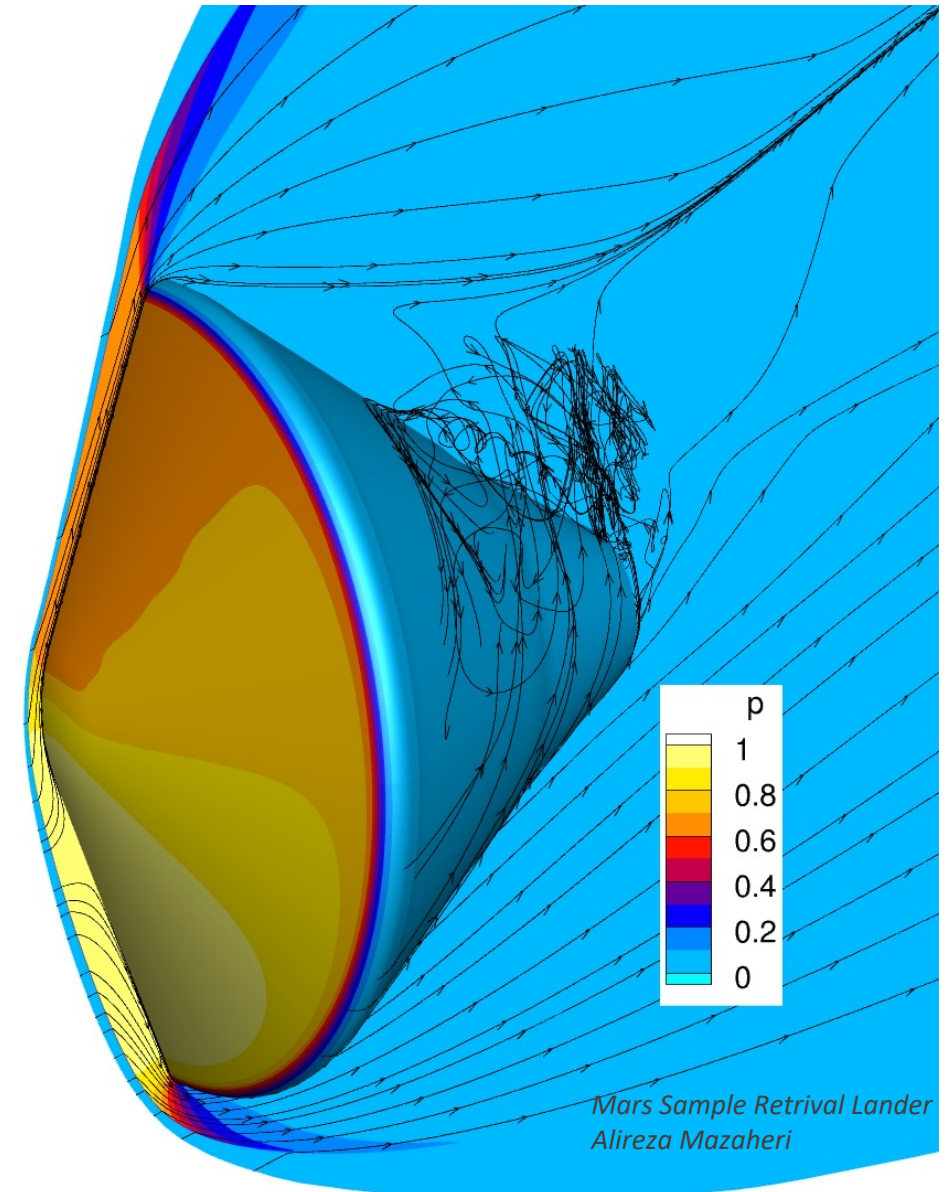

# Default Mission – Earth Entry

## Rarefied

- Drag and trim angle needed to get proper entry interface conditions

## Hypersonic

- Trim angle gradually changes as post-shock conditions change
- Capsules are typically close to neutrally stable to slightly stable
  - RCS used to damp any oscillations

## Supersonic

- Non-reacting
- Backshell aero becomes important

## Transonic

- Steep drag drop, just need to fly through here

## Subsonic

- Wake flow, shoulder separation critical
- Dynamic aero more important

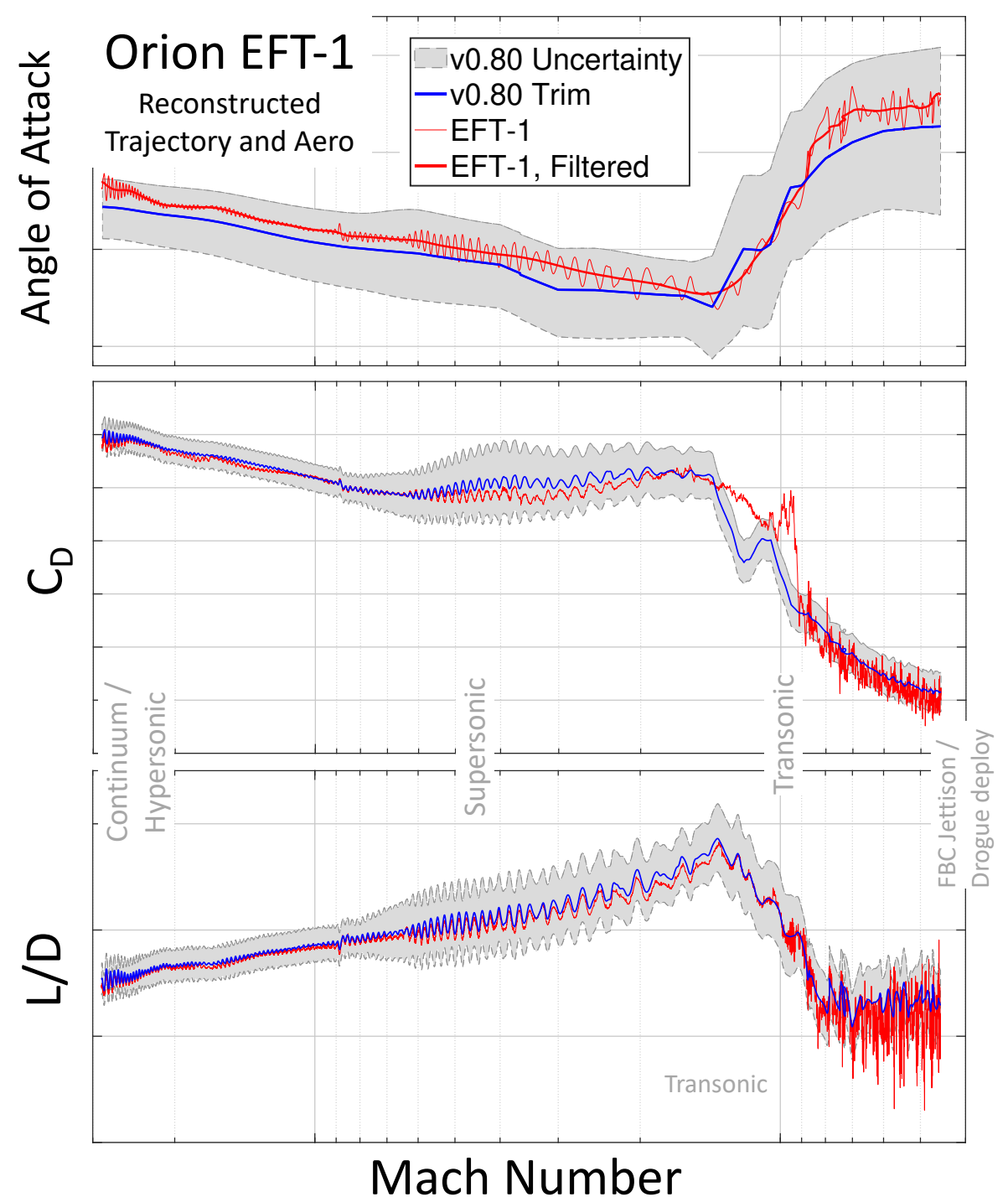

# Rarefied



## Physics

- Stochastic model of individual particles and their physics
- Probabilistic approach where simple models use cross sections determined from experiments or analytic results
- Considers translation, rotation, vibration, and electronic energy as separate modes of energy and can include chemistry and quasi-neutral ionization

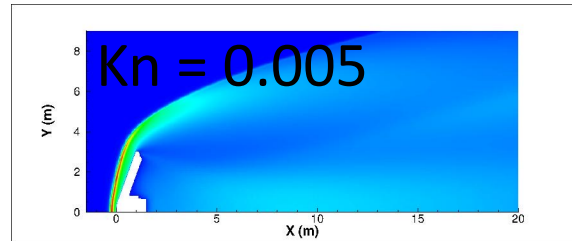
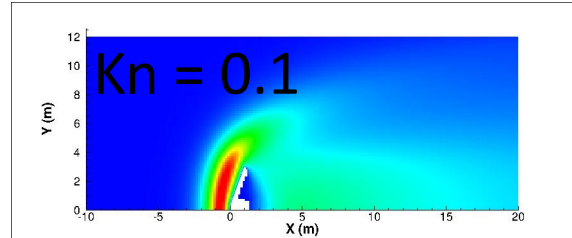

## Aero QOI

- Drag, trim angle

## Analysis Tools

- Free molecular
  - DACFree
- DSMC
  - MAP, DAC

## Analysis challenges

- Time accurate DSMC
- Coupling with CFD

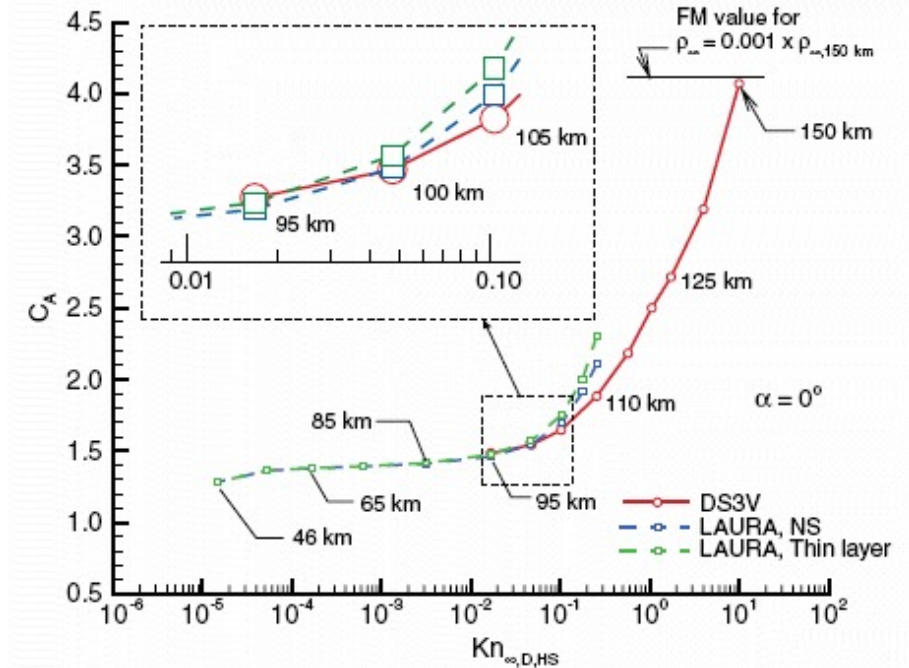
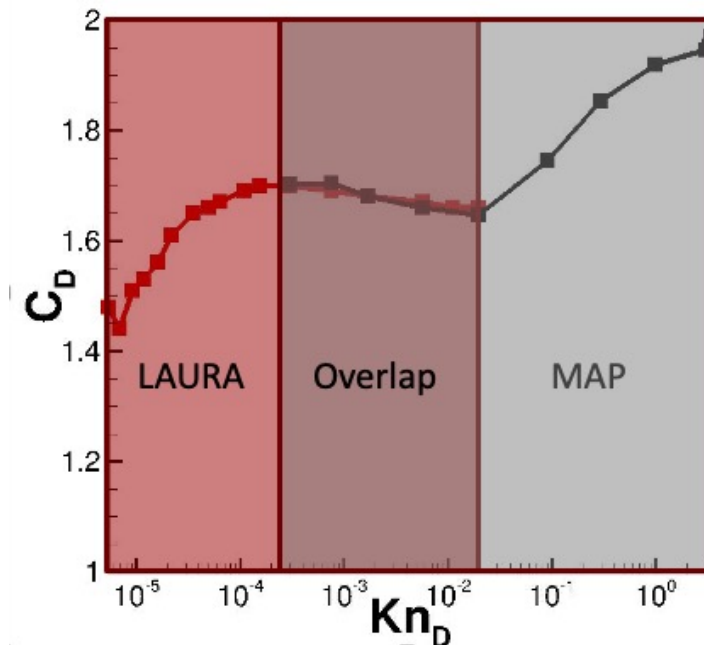

**Program:** Inflatable Re-entry Vehicle Experiment (IRVE) II – flight-test to demonstrate various aspects of inflatable technology.

**Issue:** Evaluate aerodynamic characteristics of vehicle in low-velocity, rarefied trajectory. Existing aerodynamic databases for similar configurations was not appropriate for IRVE conditions, especially at deployment from launch vehicle

**Approach:** Perform free molecular and DSMC simulations, overlapping the CFD database at lower altitudes.

**Impact:** A very strong dependency on velocity was demonstrated. IRVE shown to be statically stable in free-molecular regime but exhibited multiple stable trim points through most of the transitional regime.

# Hypersonic aero

## Physics

- Reacting flow, bow shock dominated.
  - Highest speeds are in thermal non-equilibrium
  - Lower speeds are in thermal equilibrium but still not calorically perfect
- Aero is dominated by heatshield pressure
  - Turbulent wake not important. Often aero developed is forebody only
- Trim angle gradually changes with chemistry
  - Changes in post-shock pressure and shock shape
  - STS-1 pitch-up anomaly
- Capsules are typically close to neutrally stable to slightly stable.
  - RCS used to damp any oscillations

## Aero QOI

- L/D, trim angle. L/D@M=25, CD

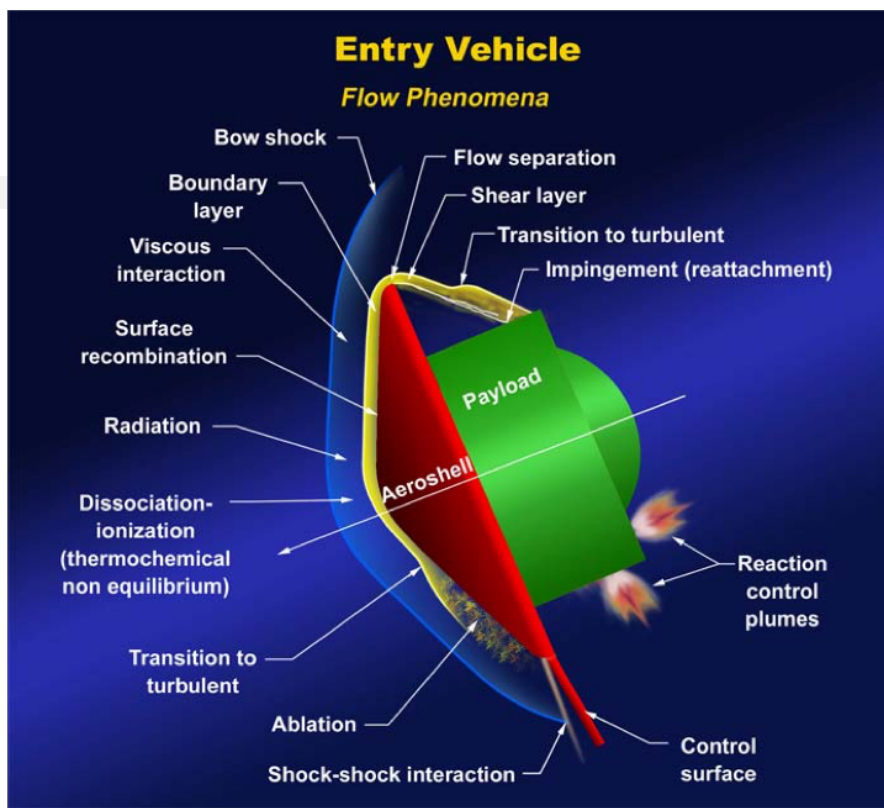

## Analysis Tools

- Newtonian
- Inviscid CFD – CART3D (equilibrium air only)
- **Reacting gas** RANS CFD – LAURA, DPLR, FUN3D, US3D
  - Choice of chemistry model is speed dependent
  - Aero typically piggy-backs on aeroheating work
- WT: LAL (Langley, Mach 6, Mach 10)
  - AEDC, others rarely used for aero

## Analysis challenges

- Wake flow, RCS JI
- Unstructured meshes for complex configurations
  - heating is an open problem

## STS-1 Landing:

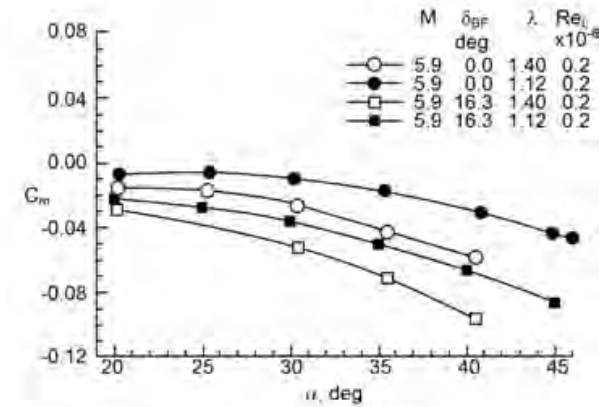
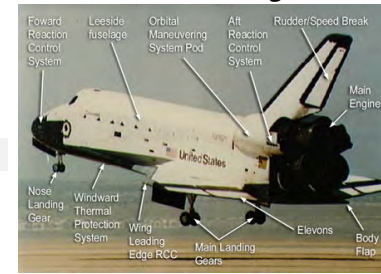

Comparison of pitching moment, air vs. CF<sub>4</sub>  
Brauckmann, et al., JSR 32.5, 1995, pp 758-764

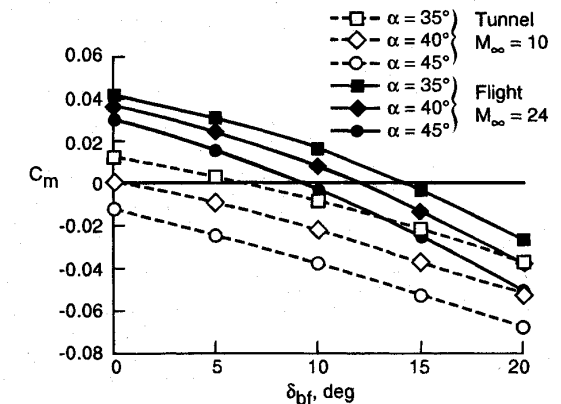

Fig. 11 Comparison of computed pitching moment based on STS-2 entry interface CG location and modified Orbiter lower surface properties.

# Hypersonic L/D



## Physics

- L/D curve is similar for most capsule shapes
- Target L/D (typically at  $M=25$ ) is determined by trim angle
- Trim angle ( $C_m=0$ ) is determined by vehicle pitching moment and zcg location
- Augmented OML shapes can shift  $C_m$  (and L/D) curve (trim tabs)

## Aero QOI

- L/D, trim angle. L/D@M=25, CD

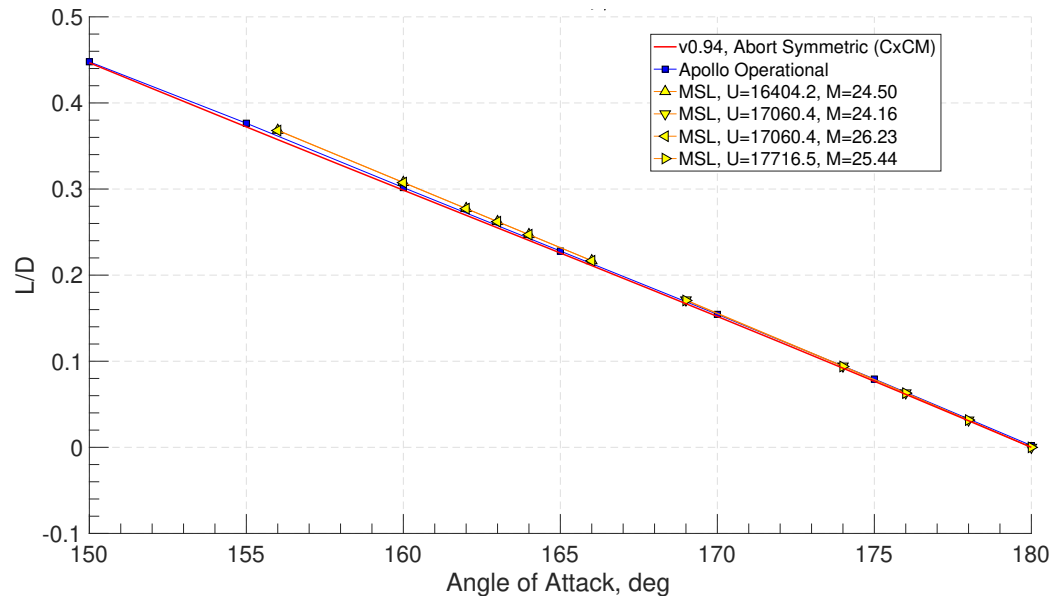

Trim Angle Change with Shift in z-cg

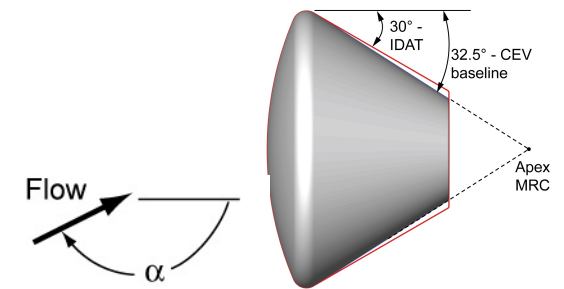
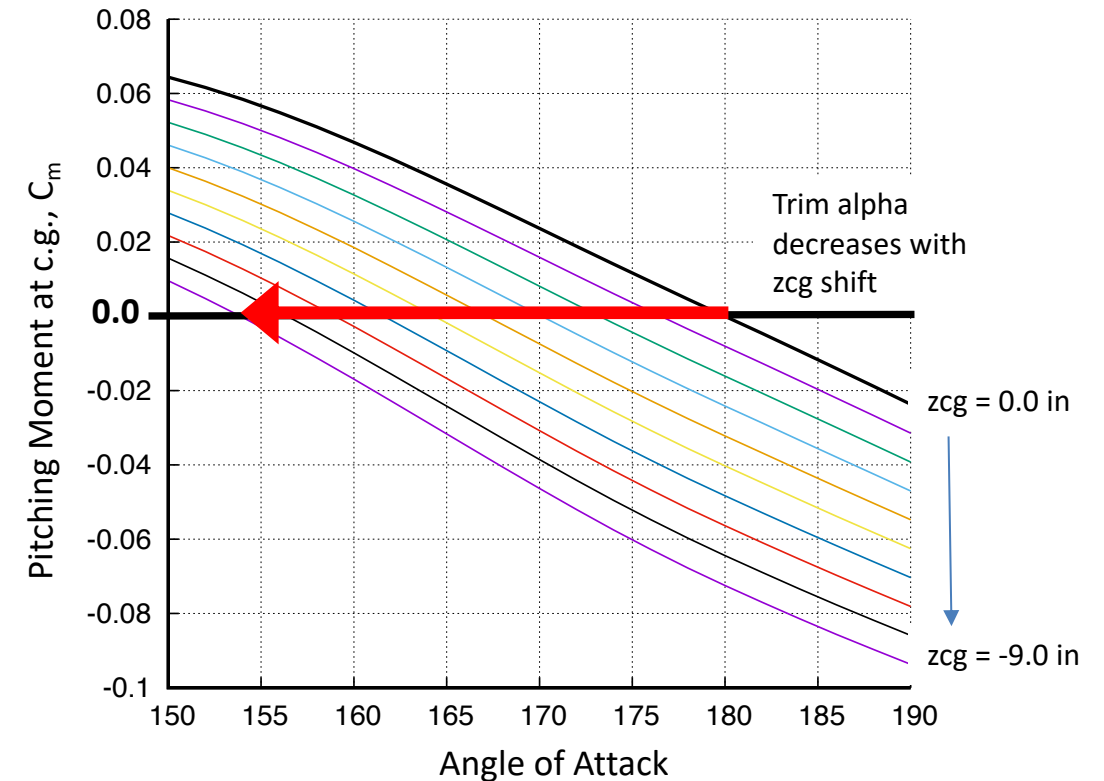

# Supersonic



## Physics

- Non-reacting.
  - Mars has strong temperature dependence in ratio of specific heat that must be modeled
- Backshell can have attached flow, higher pressures
- Generally turbulent forebody flow
- Capsules begin to be dynamically unstable
  - RCS used to damp any oscillations
  - More of an issue for Mars

## Aero QOI

- L/D, trim angle, drag, Cm<sub>q</sub>

## Analysis Tools

- RANS, DES – Overflow, FUN3D, US3D
  - Appropriate  $\gamma_{\text{Mars}}$  must be modeled
- Inviscid – CART3D for increments (Orion)
- WT - LAL (Langley, Mach 6, Mach 10)
- WT – Langley UPWT
- Ballistic range for dynamics

## Analysis challenges

- Wake flow

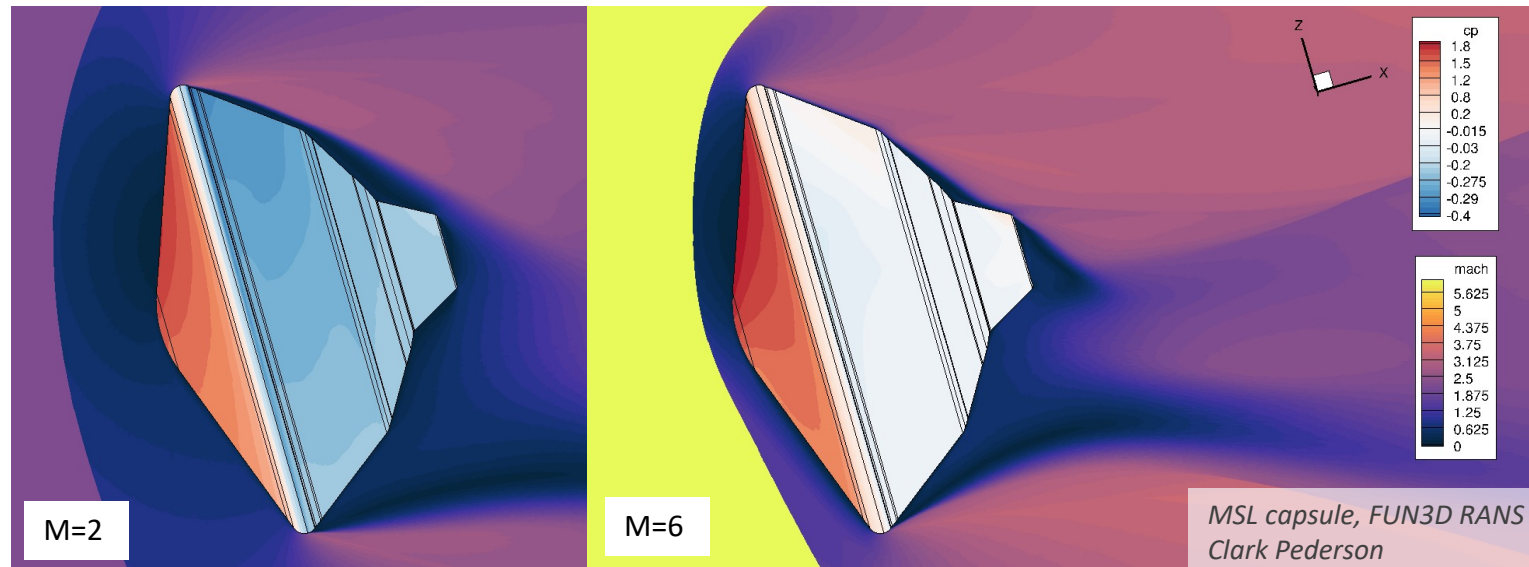
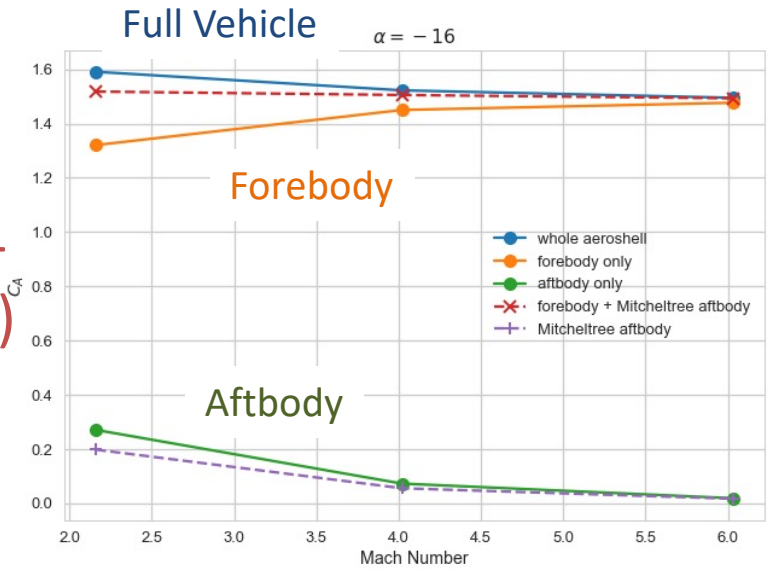
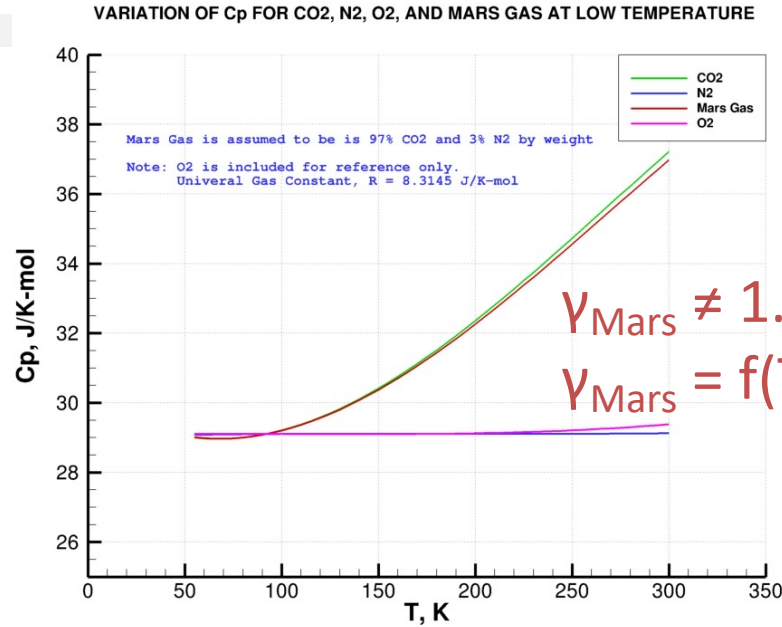

# Wake Physics: Supersonic-Transonic-Subsonic

## Supersonic

- Separation: shoulder and backshell. Attached on windside
- Compact wake
- CFD accuracy

## Changing throughout

- Inviscid aero
- Trim angle
- Dominant turbulence physics
- CFD accuracy

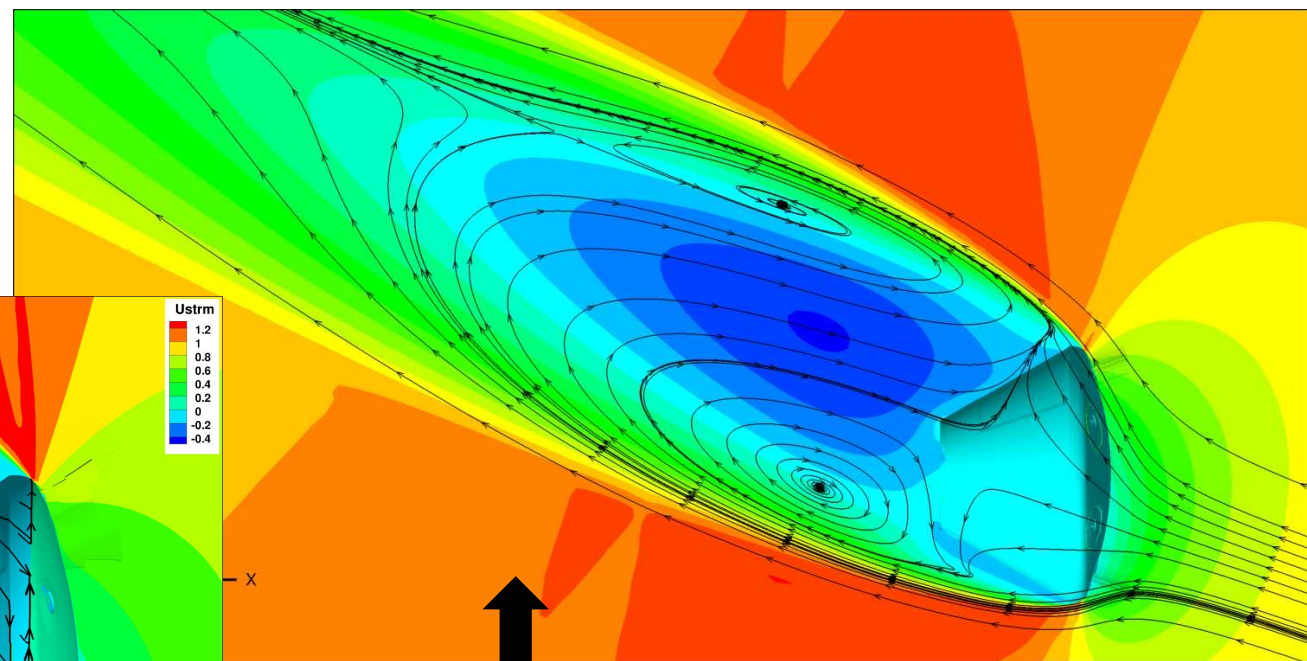
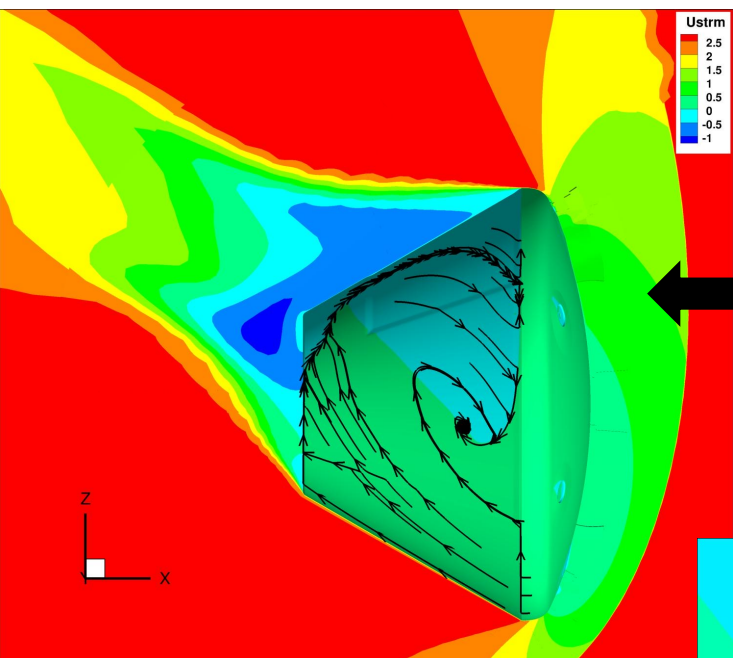

## Transonic

- Separation: shoulder with possible reattachment and backshell
- Longer, shifted wake

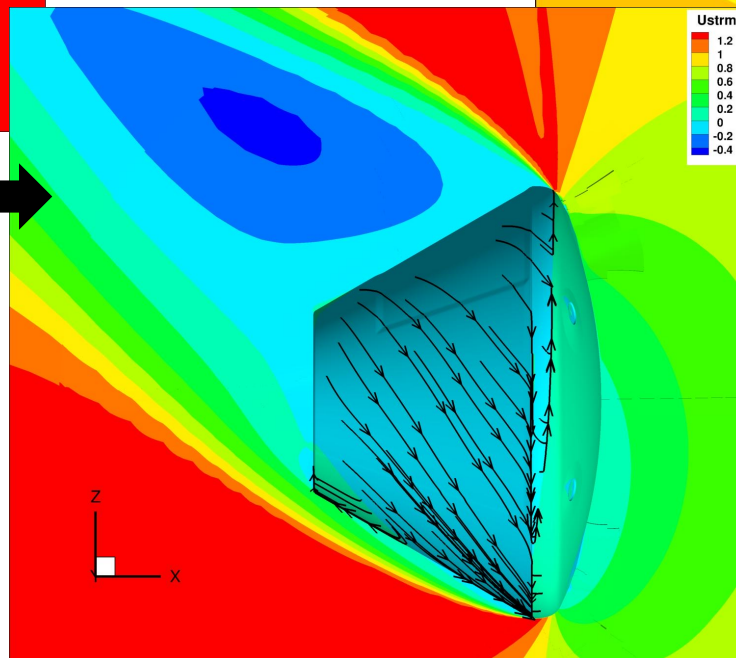

## Subsonic

- Separation at shoulder
- Strouhall shedding
- Long wake at M=0.9
- Shorter wake by M=0.3

# Transonic



## Physics

- Steep drop in drag and trim angle change through Mach 1 that is difficult to capture with analysis or in database

## Aero QOI

- Vehicle just needs to get through this region
  - Larger uncertainties are ok
  - Typically aerodatabase is 'smeared' in this region
- L/D, trim angle, drag, Cm<sub>q</sub>

## Analysis Tools

- CFD: RANS, DES – Overflow, FUN3D, US3D
- WT: Ames UPWT

## Analysis challenges

- Turbulence modeling
  - Wake flow
  - Shoulder separation
- Capturing steep drag change

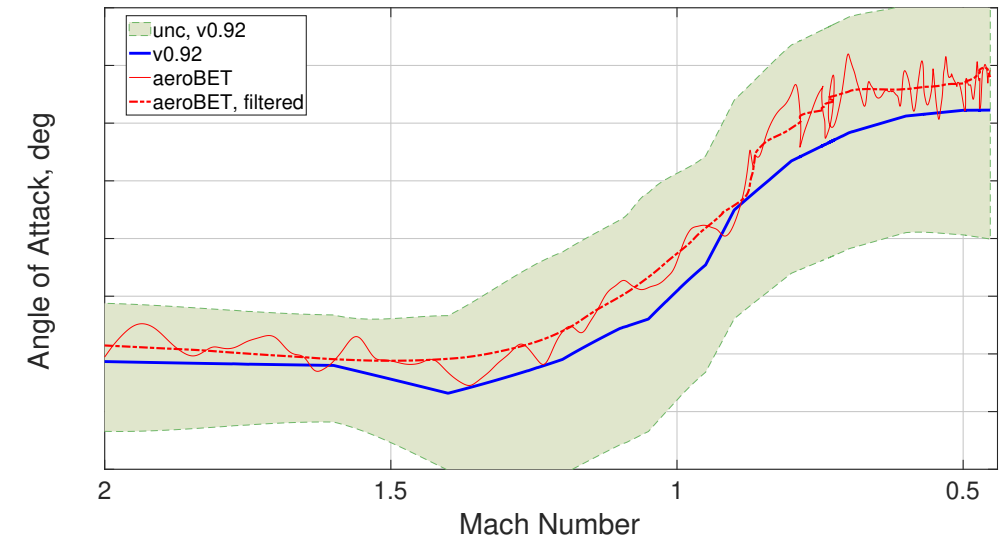
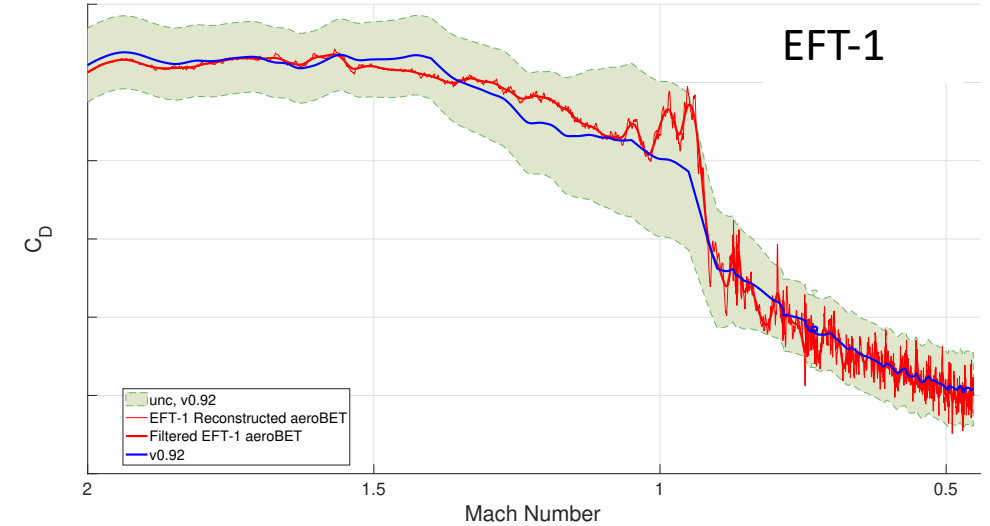

# Subsonic



## Physics

- Drag has strong Re dependency for lower Re
  - Surface roughness can change drag significantly
- Backshell can have attached flow, higher pressures
- Generally turbulent forebody flow
- Capsules are dynamically unstable
  - RCS used to damp any oscillations

## Aero QOI

- Drag,  $C_{mq}$ , trim angle

## Analysis Tools

- CFD: RANS, DES – Overflow, FUN3D, US3D
- WT Static aero: Langley NTF (flight Re), Ames UPWT
- WT Dynamic aero: Langley TDT, spin tunnel,
- Flight: Ballistic range, parachute drop testing

## Analysis challenges

- Surface roughness
- Shoulder separation point is key to drag accuracy
- Re dependencies
- RANS predicts excessive reversed-flow approaching backshell; causes elevated  $C_p$  on upper backshell
- DES CFD is becoming the requirement, with significant resource challenges
  - Open question: Can we ‘tune’ RANS to provide DES-like aero while maintaining computational throughput of RANS?

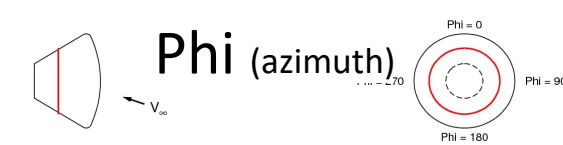
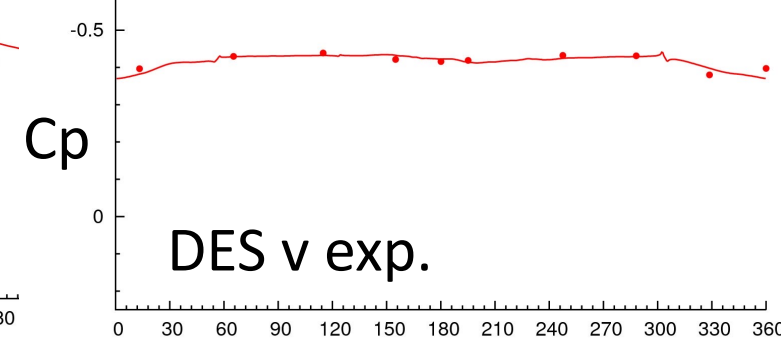
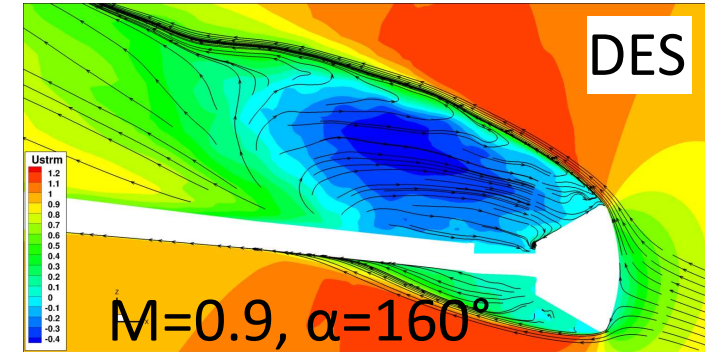
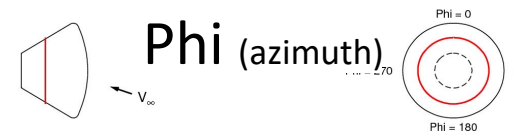
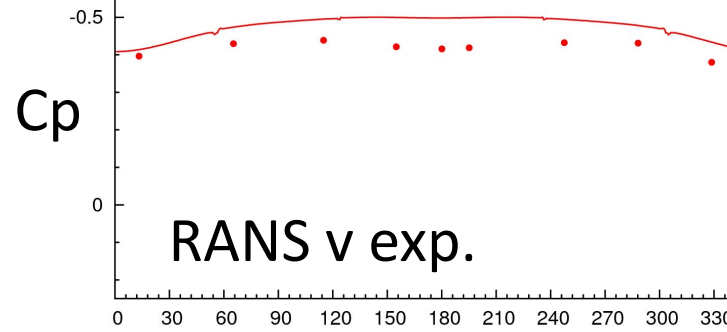
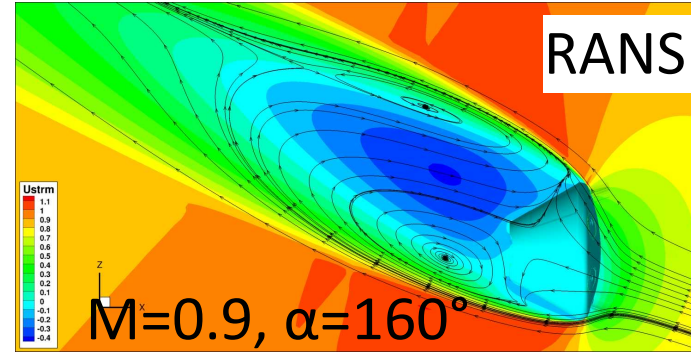

# Subsonic – Drag Prediction



## Physics

- State of boundary layer (laminar, transitional, turbulent) is Reynolds number and roughness dependent
  - BL state drives shoulder separation location, magnitude of suction spike, and therefore drag
  - Flight Re typically yield fully turbulent flow
  - Re effects diminish with increasing Mach
- Surface roughness:
  - Increases drag at flight Re
  - Reduces Re effects at lower Re by ensuring fully turbulent flow

## CFD modeling challenges

- CFD doesn't capture transition well without empiricism
  - 'Free transition' an active area of research
  - Flight Re flows are still difficult
- Selecting 'best' turbulence model requires data
  - Compressibility corrections
- Surface roughness with Knopp roughness model
  - Must be empirically set

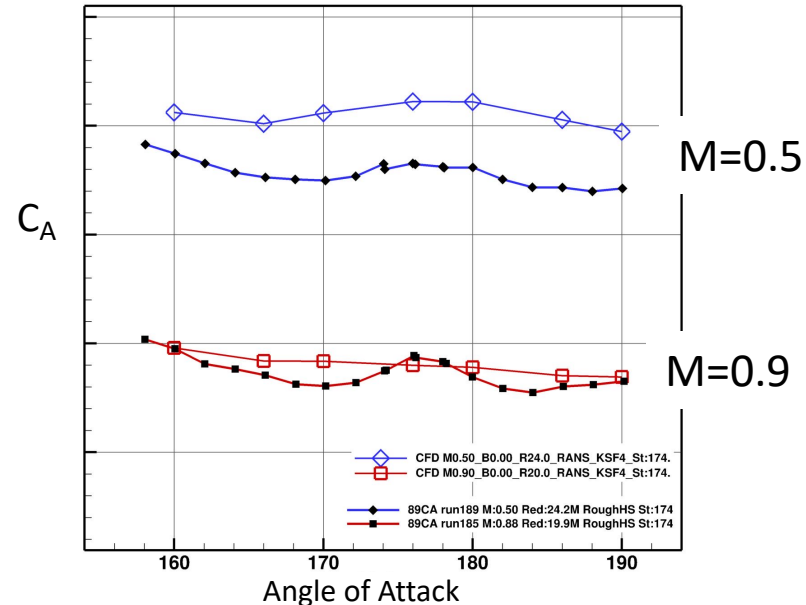
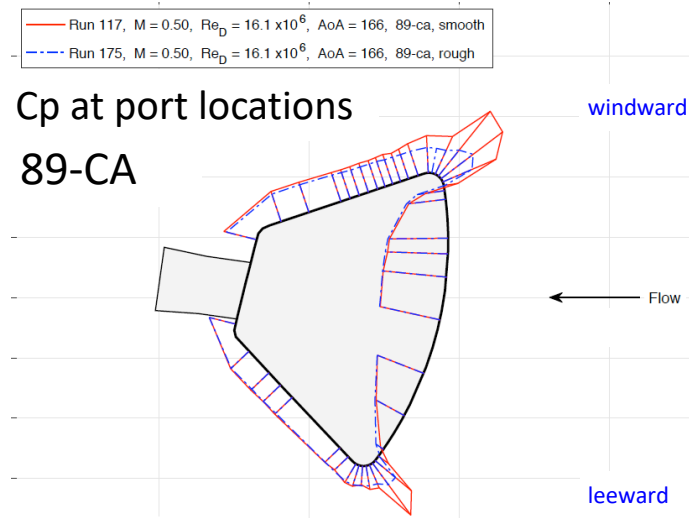

## 89-CA: Smooth and Rough

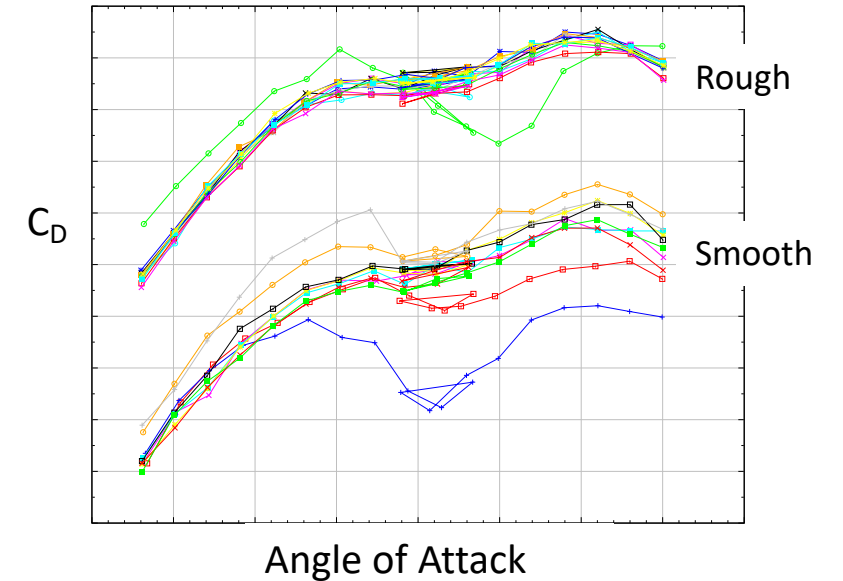

## Drag Trends

- Drag increases with Mach number
- Drag increases with surface roughness
- Re effects reduced for flight Re
  - Smooth HS has large variation for  $Re_D < 10$

# Subsonic – Drag Prediction



## Physics

- State of boundary layer (laminar, transitional, turbulent) is Reynolds number and roughness dependent
  - BL state drives shoulder separation location, magnitude of suction spike, and therefore drag
  - Flight Re typically yield fully turbulent flow
  - Re effects diminish with increasing Mach
- Surface roughness:
  - Increases drag at flight Re
  - Reduces Re effects at lower Re by ensuring fully turbulent flow

## CFD modeling challenges

- CFD doesn't capture transition well without empiricism
  - 'Free transition' an active area of research
  - Flight Re flows are still difficult
- Selecting 'best' turbulence model requires data
  - Compressibility corrections
- Surface roughness with Knopp roughness model
  - Must be empirically set

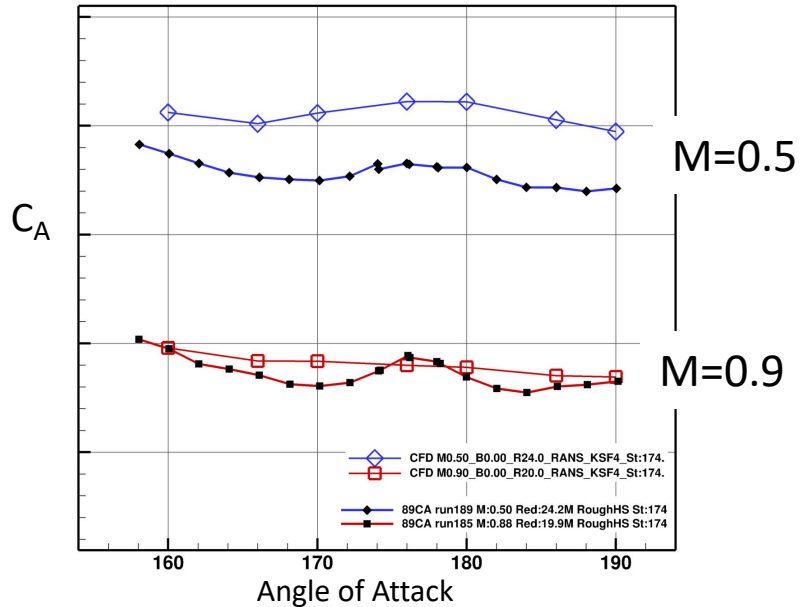
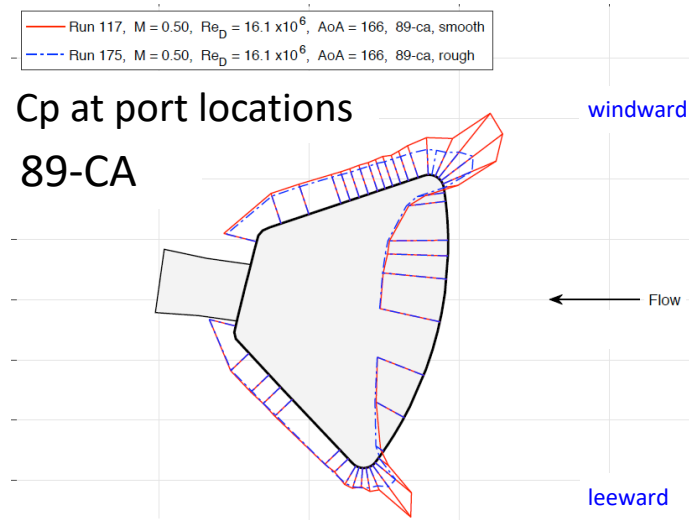

## 89-CA: Smooth Only

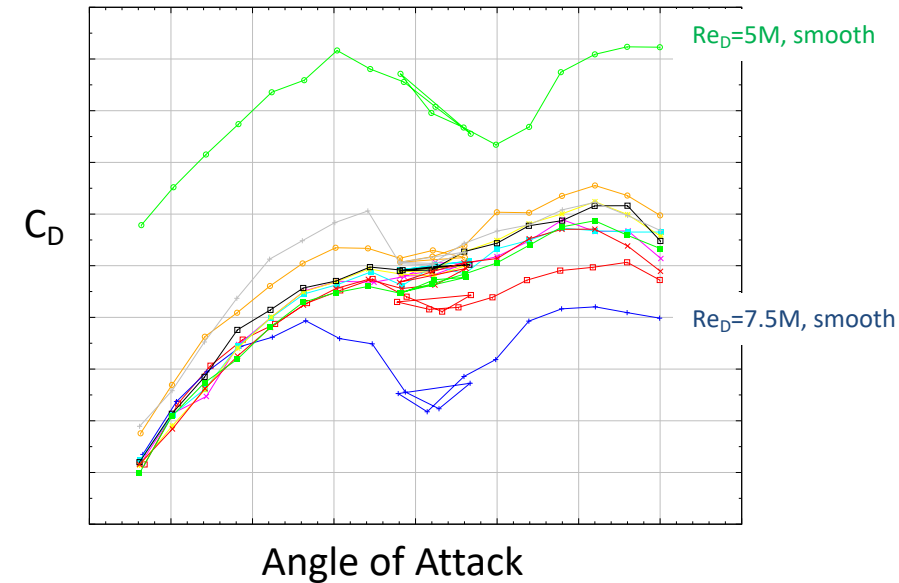

## Drag Trends

- Drag increases with Mach number
- Drag increases with surface roughness
- Re effects reduced for flight Re
  - Smooth HS has large variation for  $Re_D < 10$

# Subsonic – Drag Prediction



## Physics

- State of boundary layer (laminar, transitional, turbulent) is Reynolds number and roughness dependent
  - BL state drives shoulder separation location, magnitude of suction spike, and therefore drag
  - Flight Re typically yield fully turbulent flow
  - Re effects diminish with increasing Mach
- Surface roughness:
  - Increases drag at flight Re
  - Reduces Re effects at lower Re by ensuring fully turbulent flow

## CFD modeling challenges

- CFD doesn't capture transition well without empiricism
  - 'Free transition' an active area of research
  - Flight Re flows are still difficult
- Selecting 'best' turbulence model requires data
  - Compressibility corrections
- Surface roughness with Knopp roughness model
  - Must be empirically set

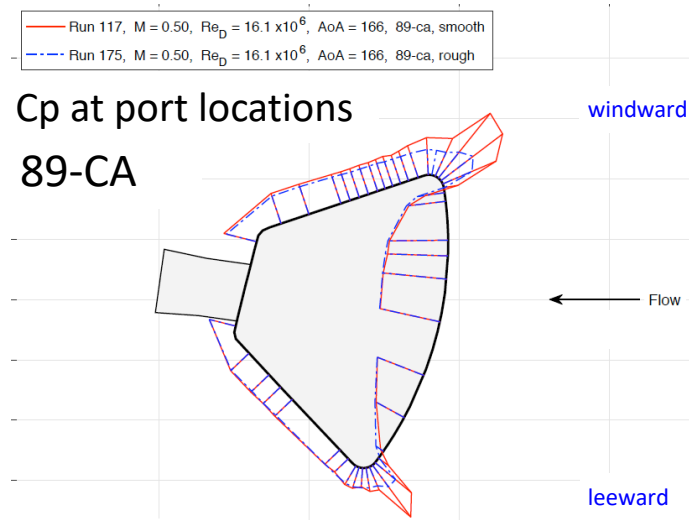

89-CA:  $Re_D > 15$  (Flight)

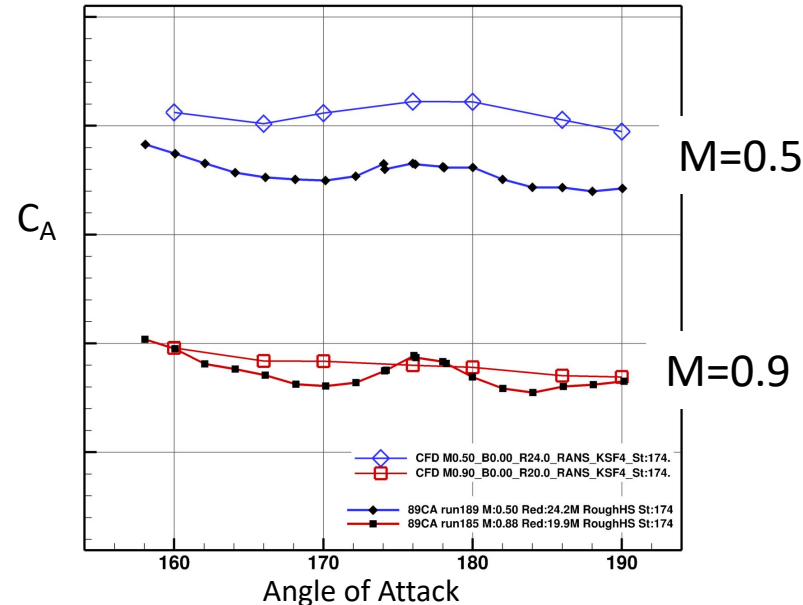
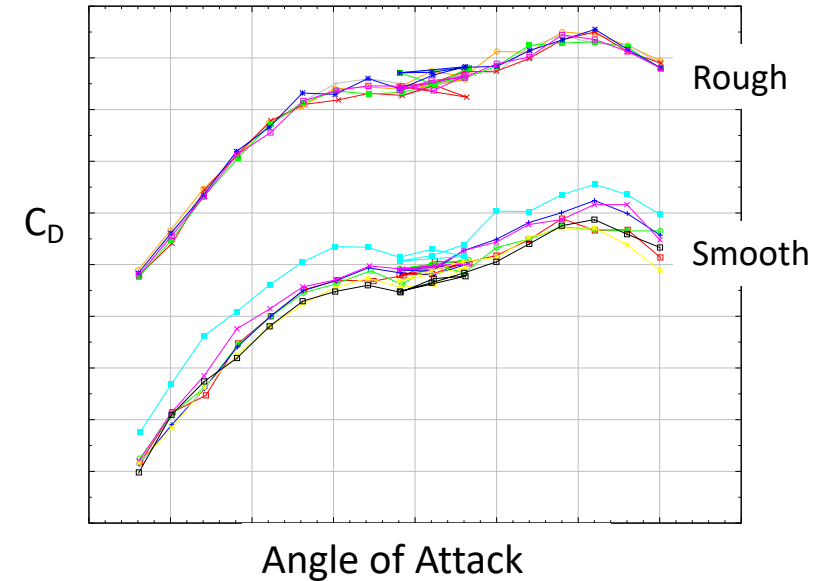

## Drag Trends

- Drag increases with Mach number
- Drag increases with surface roughness
- Re effects reduced for flight Re
  - Smooth HS has large variation for  $Re_D < 10$



More complex designs, analyses

# BEYOND THE BASICS

# L/D – trim tabs

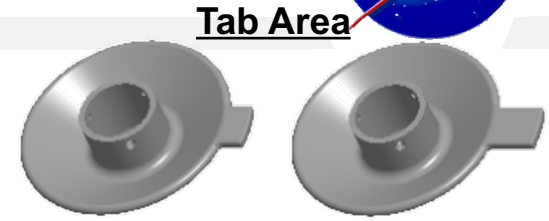
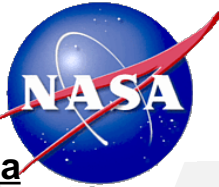
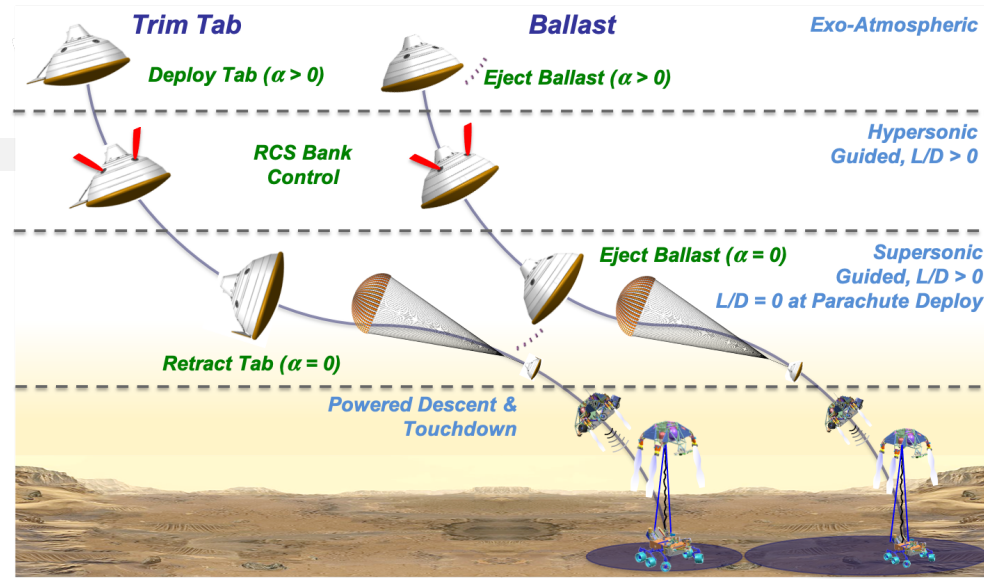
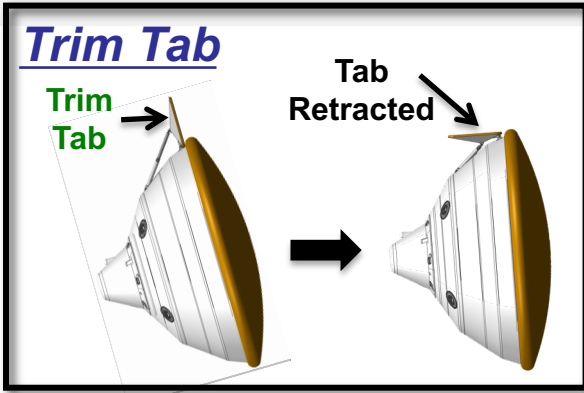

3% area

6% area

## Tab Cant Angle Example

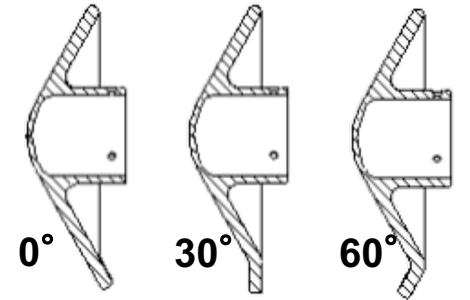

## Physics

- Aerodynamic control surfaces capable of trimming the vehicle to a non-zero angle of attack without requiring a radial CG offset
- Potentially low-mass devices, as compared to ballast or CG movement
  - MSL Ballast System (300 kg + structure) > 1 MER (174 kg)
- Deployable surfaces enable Direct Force Control
  - Ability to modulate L/D and ballistic coefficient

## Analysis challenges

- Separation, expansion, shock-boundary layer interaction in thermally imperfect gas
- Structural, thermal design and operational robustness

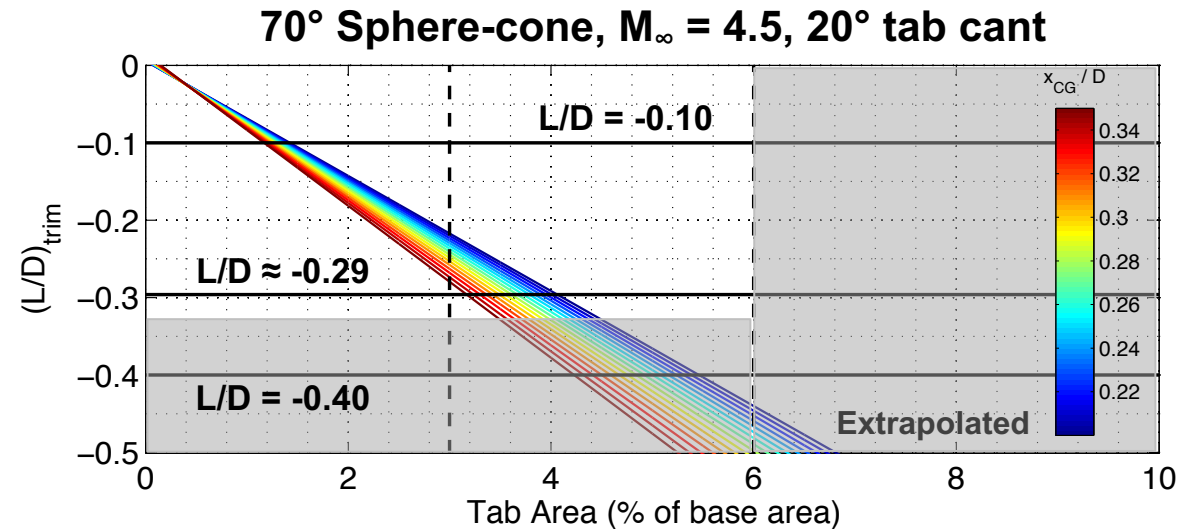

# More Drag: Retropropulsion



## Propulsive descent and landing are enabling for high-mass EDL at Mars

- Engineering analysis for trajectory trade studies assumes
  - total drag == engine thrust
- Analysis shows that vehicle contribution to  $C_D$  can be significant
  - Engine configuration and operating conditions can have significant effects on vehicle aerodynamics
  - Aerodynamic contributions decrease as the vehicle decelerates

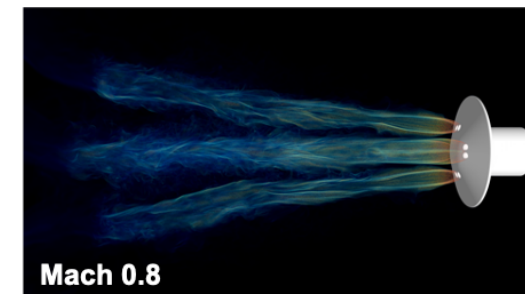
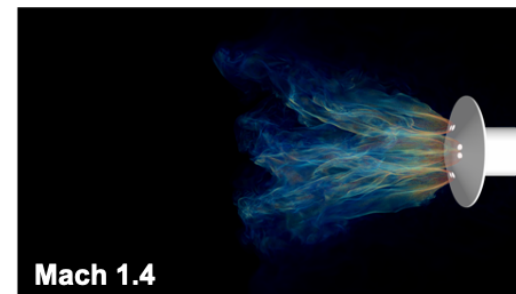
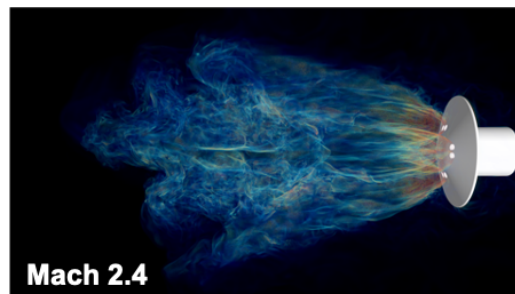
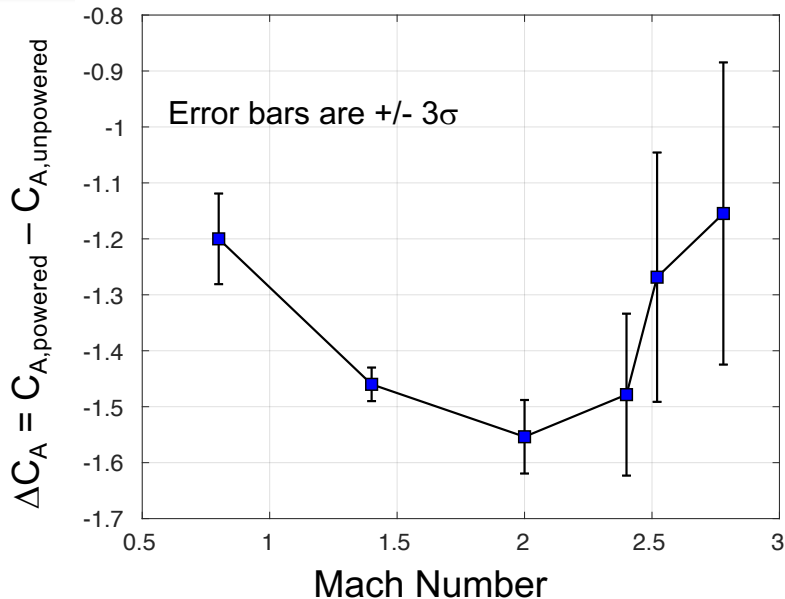
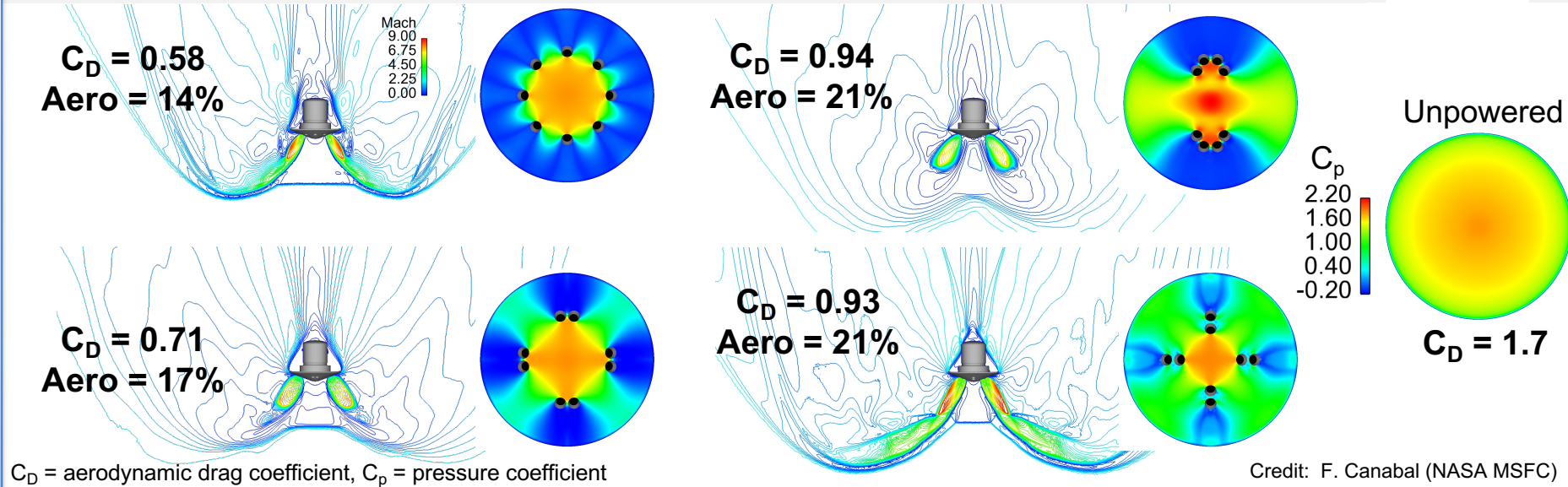

## Analysis challenges:

- Large resource requirements to resolve small scales
  - Time accuracy, fine meshes, adaptive meshes
- Chemistry and turbulence models in CFD codes are not well validated for these types of flows

*Ashley Korzun will have a whole talk on this topic*

# More drag: Flexible structures

Deployable structures designed to increase drag and extend landing timeline

- Inflatables (HIADS, SIADS) – IRVE, LOFTID
- ‘umbrella’ – ADEPT

Analysis challenges:

- How do we handle the flexible structures?
- Resolving wake flows with structured grids required advances in grid topology coupled with hypersonic bow shock adaptation

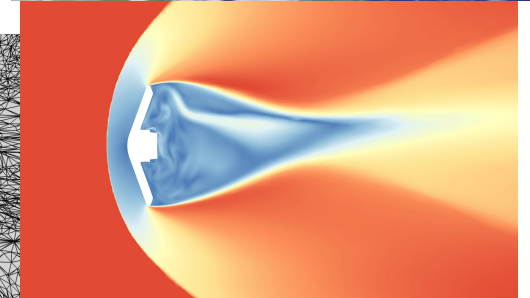
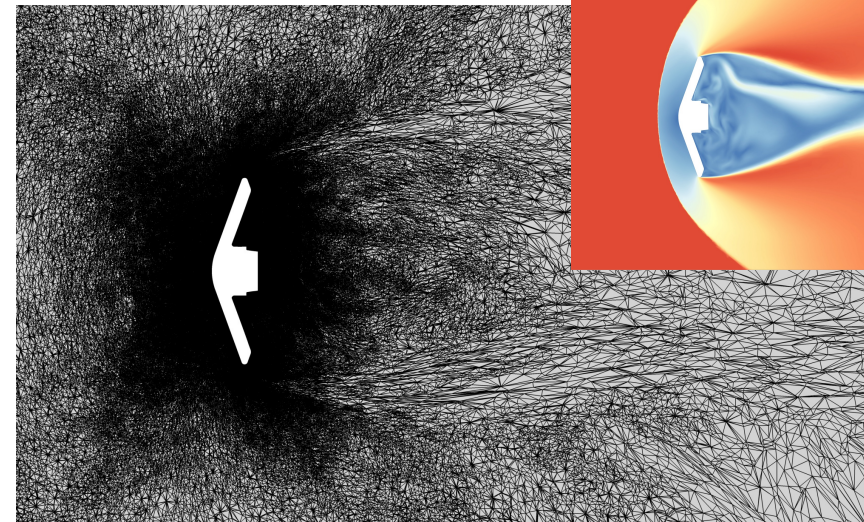
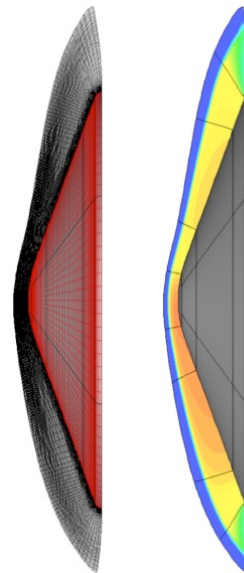
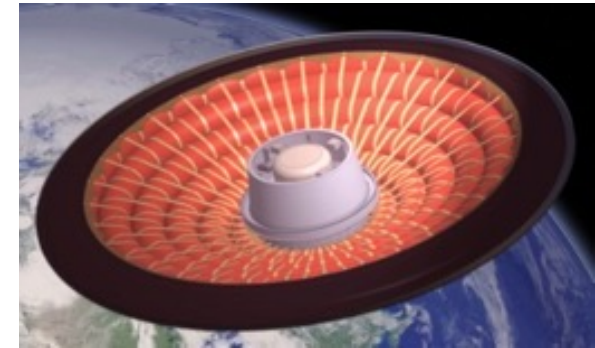
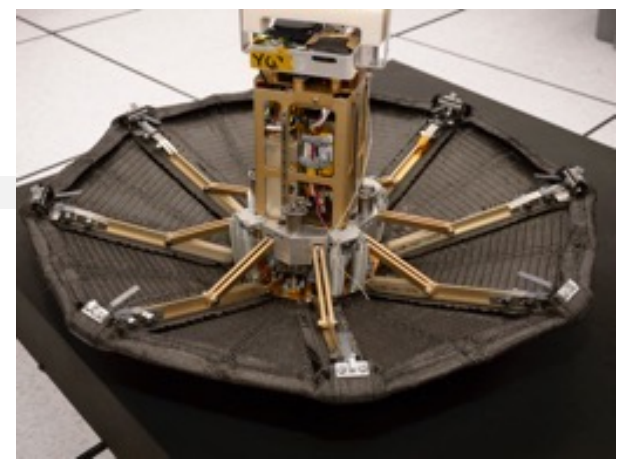
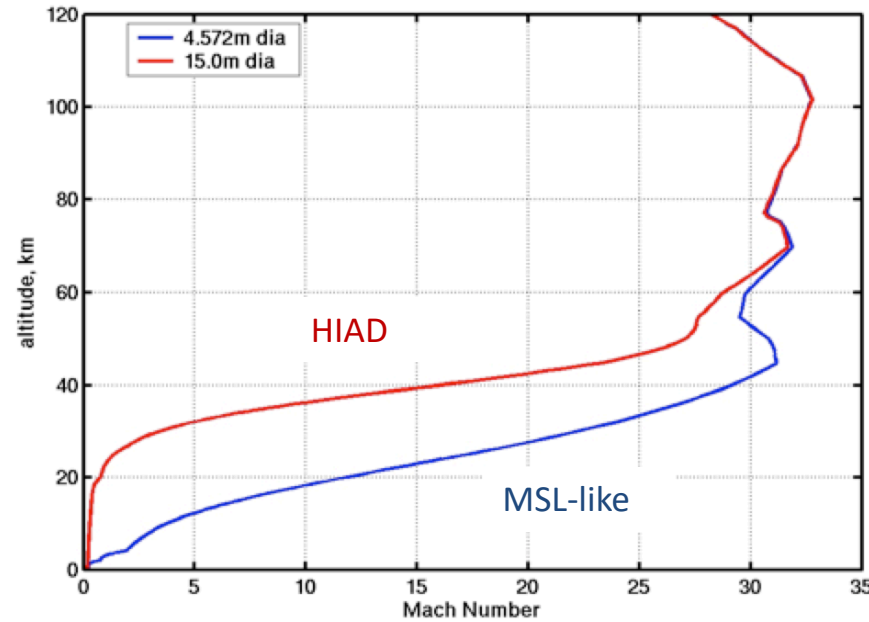

# Control: Jet interactions – RCS

RCS JI is the change in the aeroshell aerodynamics due to presence of the jet.

- Not (typically) an aerodynamic issue hypersonically
- Can be a concern as Mach decreases
- We try to design it away rather than characterize the JI.

## Analysis challenges:

- Separated wake flow needs DES to characterize well. This can matter at lower Mach
- At high Mach, wake can be rarefied (DSMC)
- WT testing is complicated
  - magnitude of interactions can be smaller than balance accuracy
  - Matching reacting plumes in tunnel with inert, cold gases is difficult

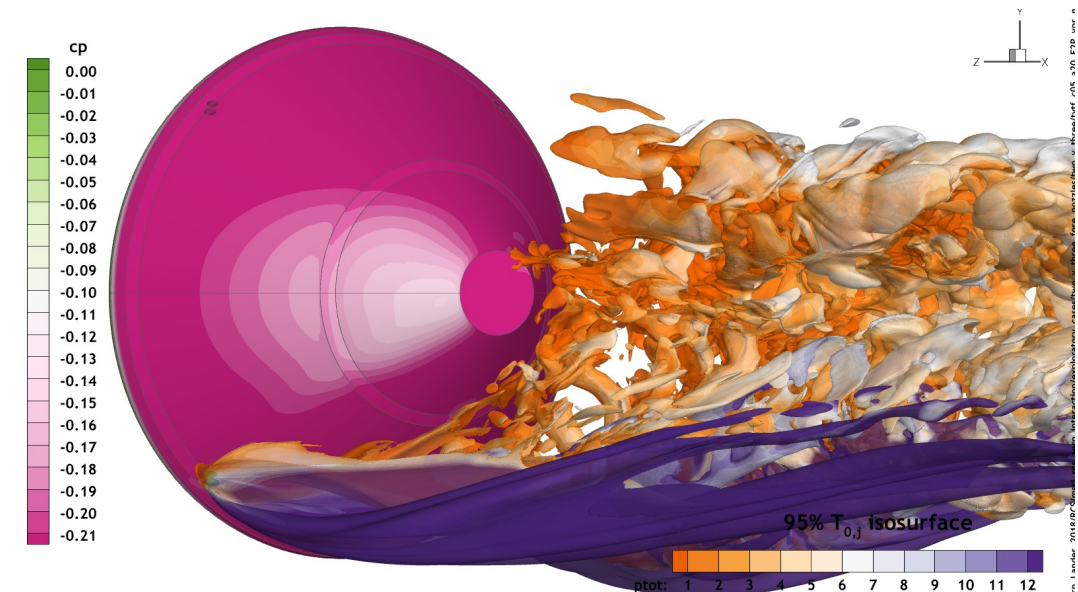
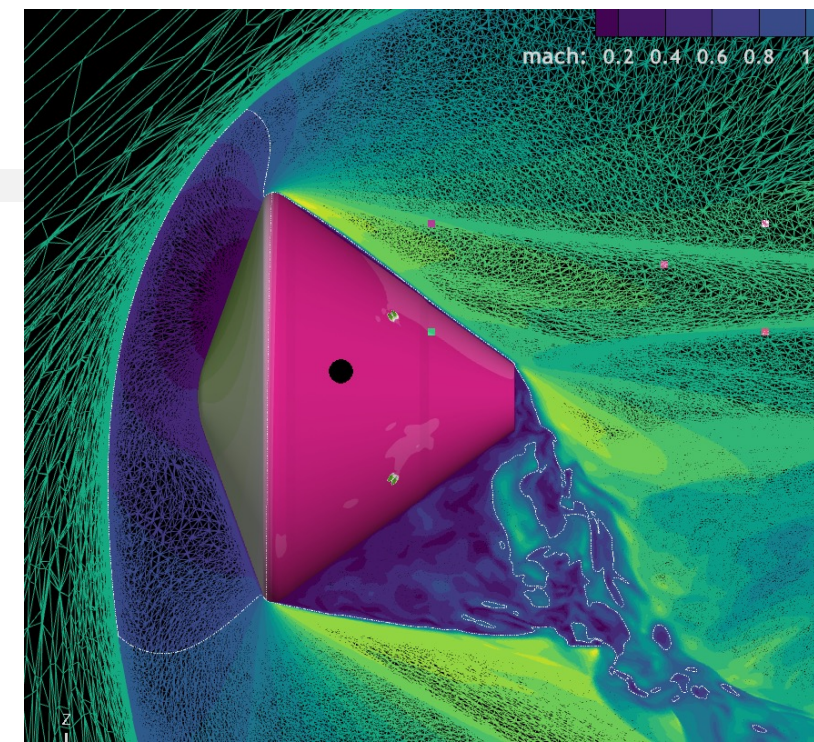

Mars SLL, FUN3D DES  
Karen Bibb, Bil Kleb

# Free Flight CFD Simulation

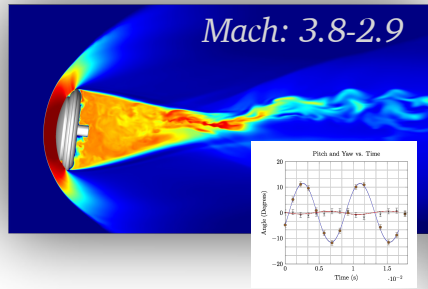

Free-Flight simulations validated against experiment

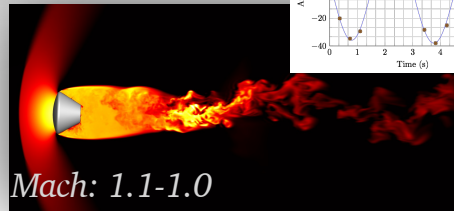
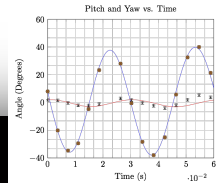
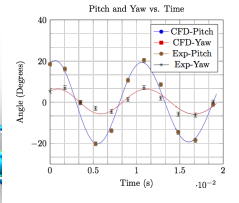
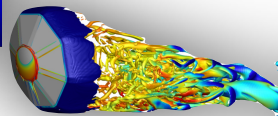

## Free-Flight CFD

- Dynamic aero-coefficients historically obtained exclusively through ground/flight experimentation
  - Static aero-coefficients can be generated using validated CFD simulations with large databases anchored to experiments
- Moving the computational mesh in response to fluid forces coupled with translation velocity augmentation to discrete equations allows for full 6-DoF simulation of free-flying objects
  - Additional control of individual DoF allows for a range of analysis to be carried out (i.e.: free-to-pitch, forced oscillation, etc)
- Validation of the capability has been carried out for the past 5 years
  - Using various ground test free-flight facilities such as ballistic ranges as well as flight experiments
- The inclusion of an atmosphere model (EarthGRAM) allows for atmospheric flight to be simulated
  - Flight scale simulations can be run to support ground test and ballistic range scale simulations to better understand ground to flight traceability

## Atmospheric flight simulation with EarthGRAM

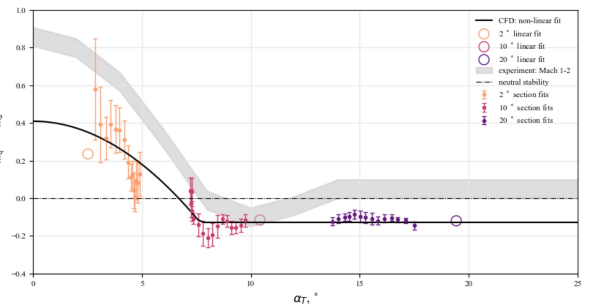
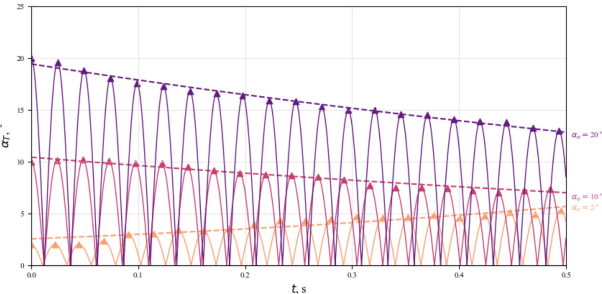
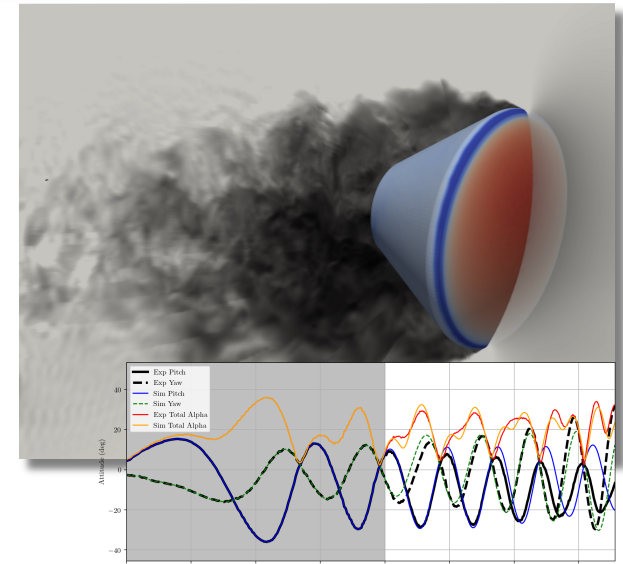
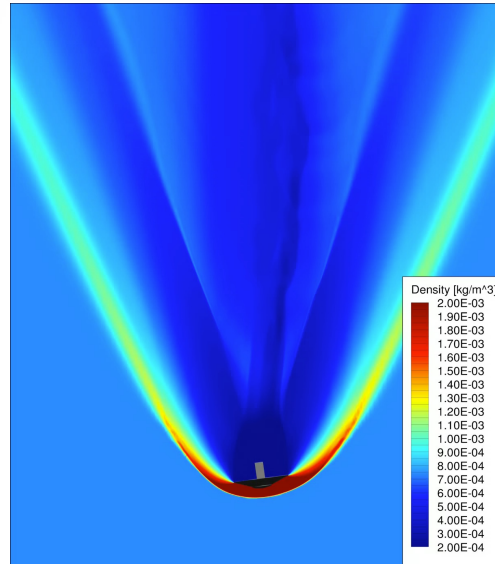

Obtaining dynamic aero-coefficients exclusively FFCFD

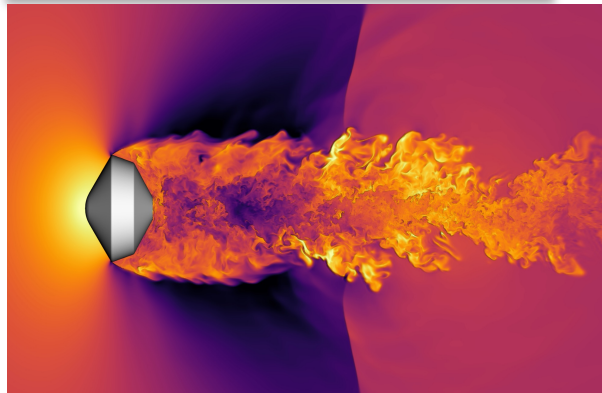



- Aerodynamic Reconstruction
  - Accelerometer data to determine aero forces and moments
- FADS –  $(q, p, \alpha, \beta)$  from least squares fit of flight pressures to calibration database
  - Aero responsible for calibration database,  $C_p(M, \alpha, \beta)$ ,  $uC_p(M, \alpha, \beta)$
- Motion matching – determine database UFs that best match flight to database
  - Trajectory simulations
  - Parameter ID methods
- Pressure measurement comparisons
  - Flight data can help us improve our CFD tools and understand the physics better

# Summary for Analysis Methodologies



## Ground-based testing

- Not a perfect analogy for flight, imperfect measurements
- Re limitations, high enthalpy limitations
- Very useful for CFD validation
- Most important for dynamics and subsonic capsule aero.

## CFD / DSMC

- Models don't fully simulate reality, but we have very good characterization of the models.
- Separated flows, chemistry modeling, ablation are all challenging.
  - Turbulence effects are primary limitation
- Primary tool for hypersonic/rarefied

## Flight

- VERY limited knowledge of the perfect simulation.
- Primary use is aerodynamic database validation, not database development
- Critical to collect as much data as possible from every flight / flight test



Synthesizing all of the aerodynamic data to be use by our customers

# **AERODATABASE**

# Aerodatabase Basics



## Aerodatabase Development

- Formulation
  - Nominal, uncertainties, dispersions
- Response surface development
  - Independent parameters, coverage
  - Single source, blending
  - Simple interpolation, ML methods
- Provide database to customers
  - API (Orion, MSL)
  - Models that customers implement (SLS)

## Aerodatabase Usage

- Trajectory development
  - Nominal, dispersed
  - Stressing trajectories
- Aerodynamic loads

Database provides **dispersed** aerodynamic coefficients

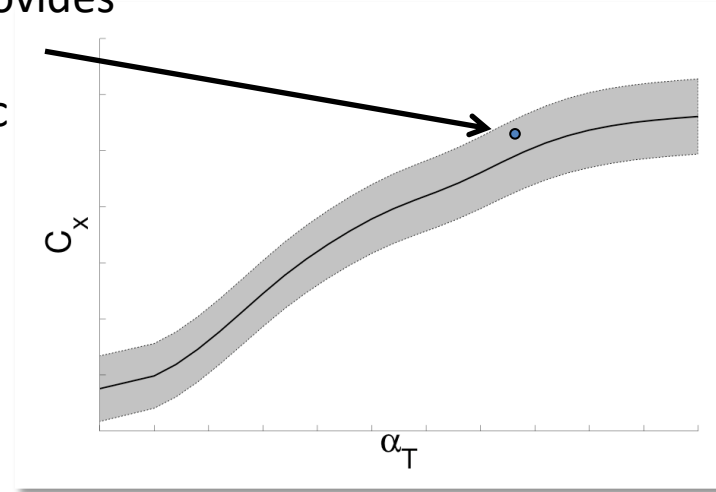

Uncertainty factor provided by user. For uniform distribution, between  $\pm 1$

$$C_x | \text{dispersed} = \underbrace{C_x(M, \alpha_T)}_{\text{Nominal coefficient}} + \underbrace{UF_{C_x}}_{\text{Uncertainty factor provided by user. For uniform distribution, between } \pm 1} \underbrace{uC_x(M, \alpha_T)}_{\text{1-}\sigma \text{ uncertainty bound on coefficient}}$$

Nominal coefficient

1- $\sigma$  uncertainty bound on coefficient

# Aerodatabase Formulations – MSL Static



**Formulation defines the necessary terms to provide the 6 aero coefficients, dispersed.**

- Aerodatabase provides model for each term as a function of independent variables
  - Essentially, a response surface
- Uncertainties are used, with dispersion model, to provide dispersions on nominal coefficients
  - Uncertainties on aero coefficients are decoupled
    - Allows for trajectory studies to understand effect of larger uncertainty for one parameter at a time
  - ‘adders’ for bias and trim angle, ‘multipliers’ for dispersing the slope and static stability
    - Orion uses slope uncertainties only for pitch and yaw
- Dispersions can be defined as normal, uniform, or any other appropriate distribution

$$C_{A_{Disp}} = C_A(\alpha, \beta)(1 + U_{C_A}^M)$$

$$C_{N_{Disp}} = [C_N(\alpha, \beta) + U_{C_N}^A] (1 + U_{C_N}^M)$$

$$C_{Y_{Disp}} = [C_Y(\alpha, \beta) + U_{C_Y}^A] (1 + U_{C_Y}^M)$$

$$C_{m_{Disp}}|_{cg} = \left[ C_m(\alpha, \beta)|_{MRP} + \frac{\Delta x}{d} C_N(\alpha, \beta) - \frac{\Delta z}{d} C_A(\alpha, \beta) + U_{C_m}^A \right] (1 + U_{C_m}^M)$$

$$C_{n_{Disp}}|_{cg} = \left[ C_n(\alpha, \beta)|_{MRP} + \frac{\Delta x}{d} C_Y(\alpha, \beta) + \frac{\Delta y}{d} C_A(\alpha, \beta) + U_{C_n}^A \right] (1 + U_{C_n}^M)$$

$$C_{l_{Disp}}|_{cg} = \frac{\Delta y}{d} C_N(\alpha, \beta) - \frac{\Delta z}{d} C_Y(\alpha, \beta) + U_{C_l}^A$$

Step1: Disperse Trim Angle  
Adder applied at final cg

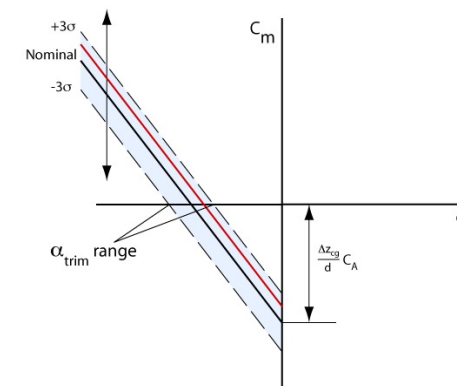

Step2: Disperses Slope  
Multiplier applied at final cg

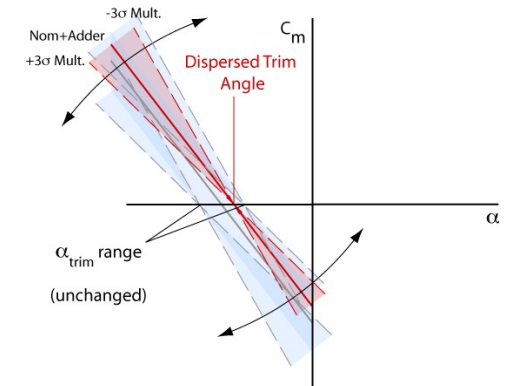

# Response Surface Development

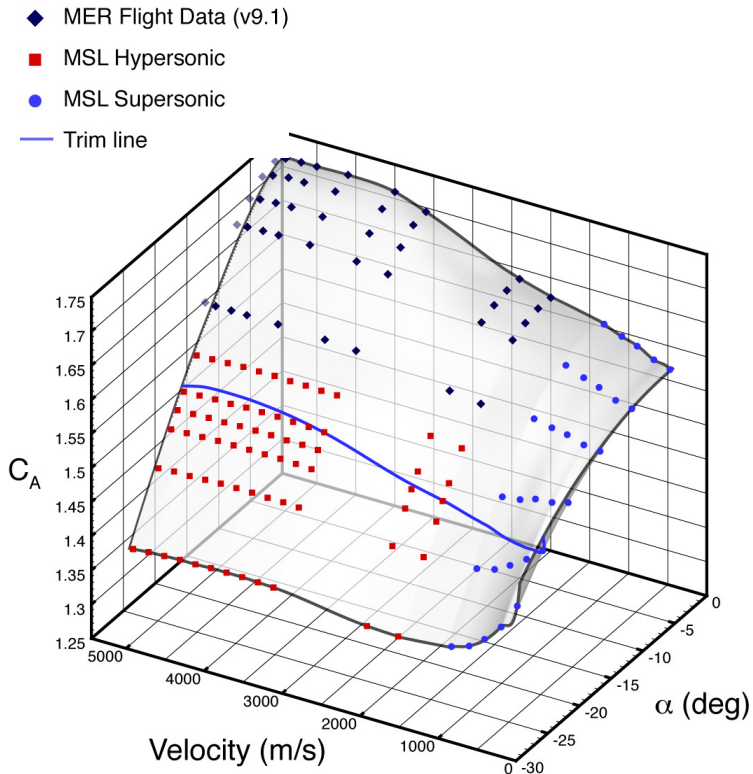

**MSL Aerodatabase**  
 $C_A$ , Data and Database

## Data sources must be combined into single model

- MSL typically uses single data source for nominal
  - Database uses biparabolic interpolation to provide  $C_x(V, \alpha)$
- Orion combines multiple sources using different approaches in different speed regimes
  - Database uses linear interpolation of a final table of data to provide  $C_x(FMV, \alpha, \beta)$
- Machine learning and higher order modeling are active research topics

Single  $(FMV, \alpha_T)$  in database

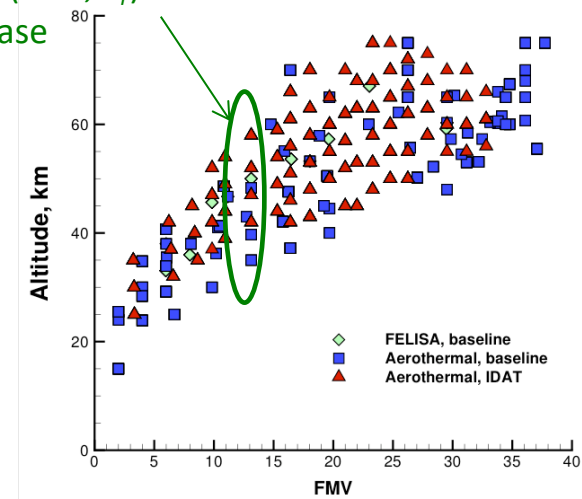

**Orion Aerodatabase**  
 $C_D$ , Data and Database  
 (hypersonic only)

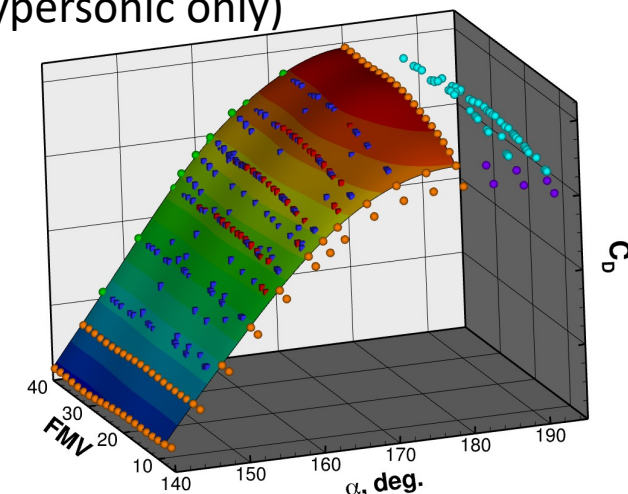

# Uncertainty Development – MSL



Uncertainty model development strategies vary more than the nominal aero analysis

**MSL uncertainties are set based on heritage ranges, and numerous analyses performed to support (and adjust) those ranges**

- Uncertainties that produced adverse performance in simulation were assessed in more detail to better inform the model implementation and uncertainty levels.
  - persistent roll torque
  - hypersonic pitching moment
- Sensitivity studies for specific phenomena (ablation, deformation, gas chemistry, etc.) run with trajectory sims

## MSL Aerodatabase

$C_A$ , uncertainties and additional data sources

$$uC_A = \pm 3\% C_A$$

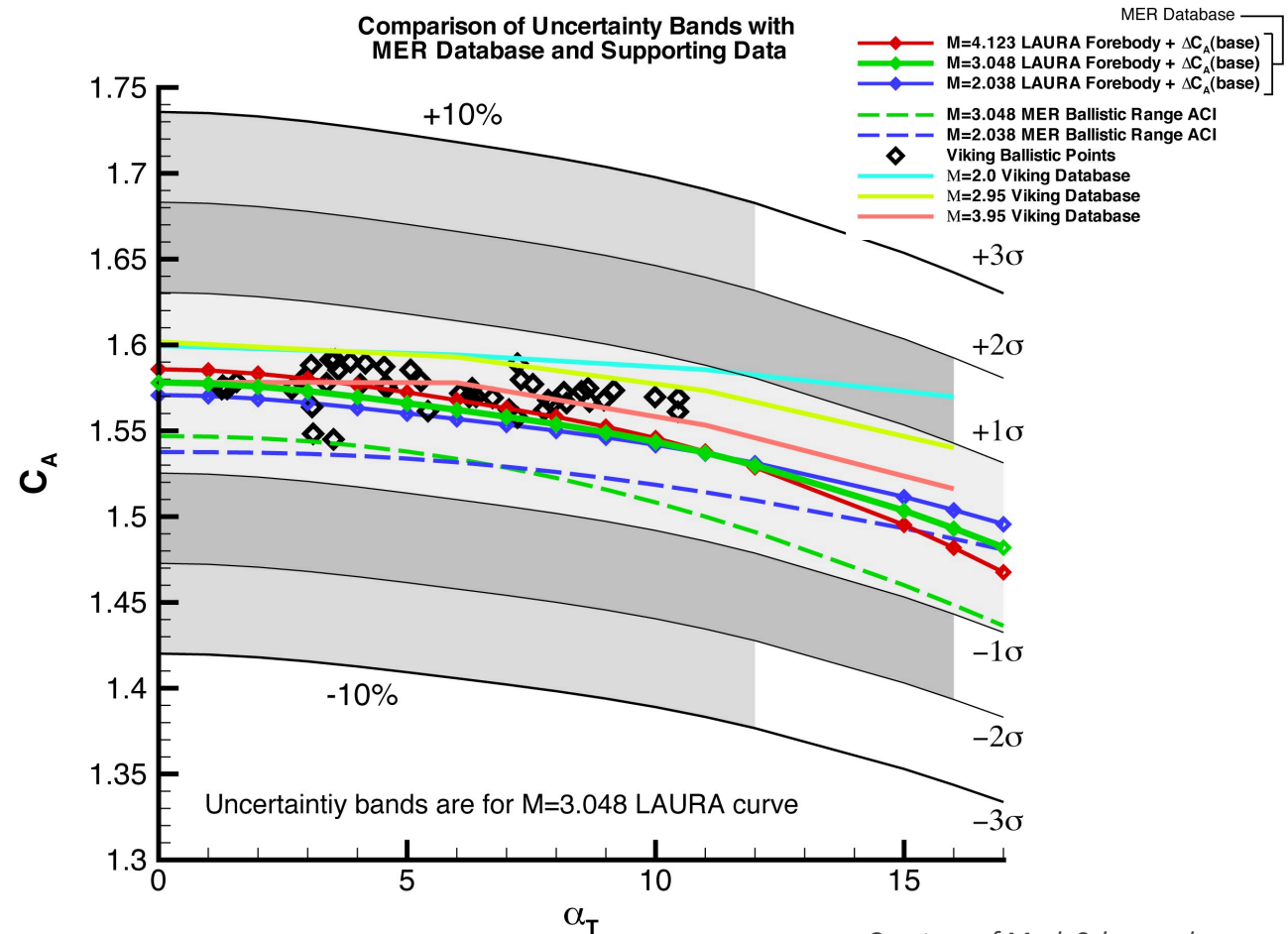

# Uncertainty Development – Orion

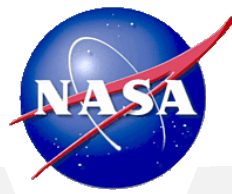

## Orion: individual contributors to error are combined

- Each analysis has associated uncertainties
- Database model has additional uncertainties
- Not shown, we always have a ‘flight’ term that covers how well our models are expected to simulate flight

## Based in statistical process control theory

- Variational terms are RSS'd
- Coverage terms are added
- Multipliers used for poorly quantified terms

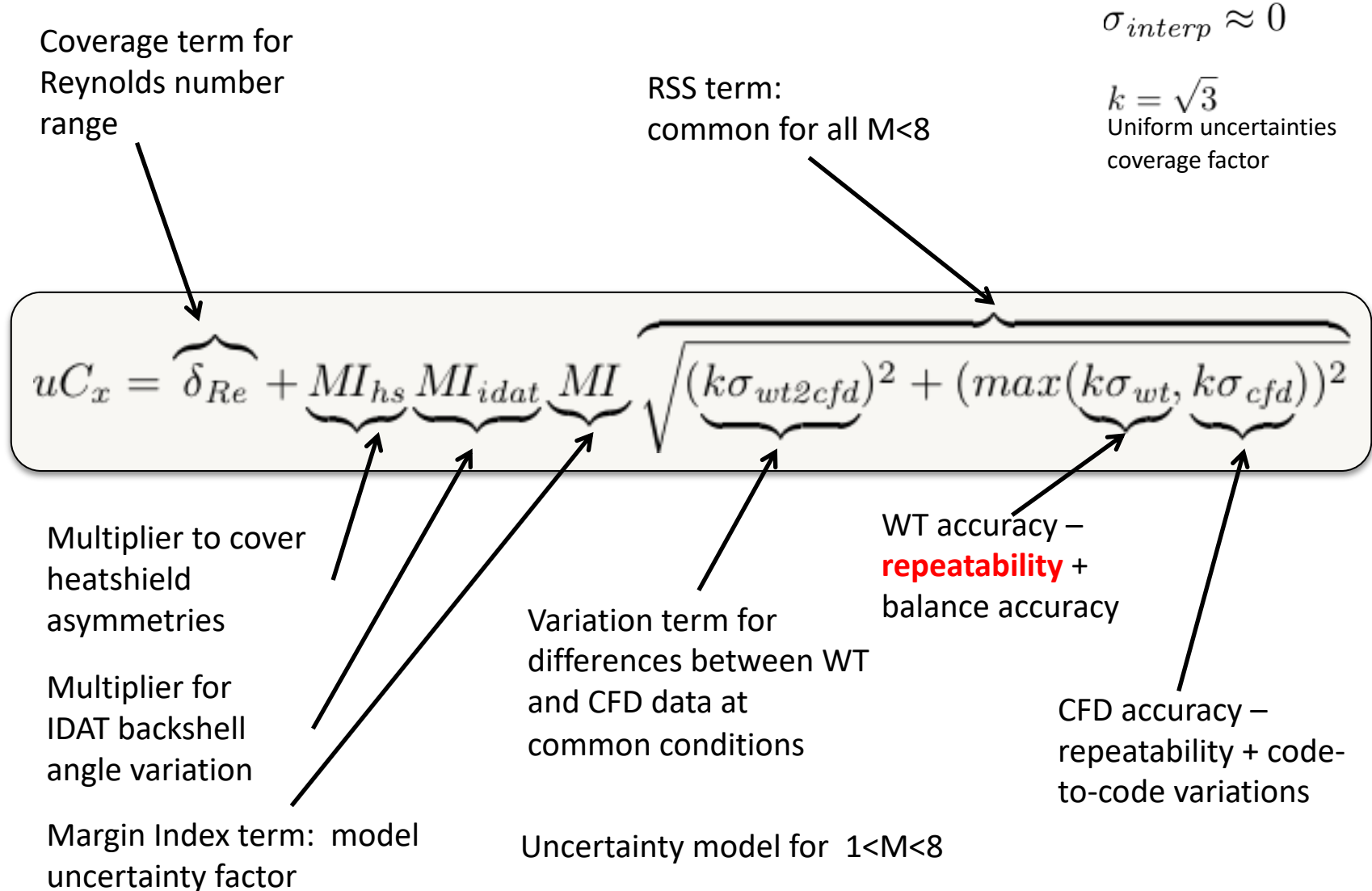

# Trajectories and Aerodatabases



## GNC uses the aerodatabase with dispersions when running Monte Carlo trajectory simulations

- Trajectory provides state ( $M$ ,  $\alpha$ ,  $\beta$ , etc) and uncertainty factors
  - UFs drawn based on (aero) specified distributions
- Aerodatabase returns the 6-DOF dispersed aero coefficients

## GNC looks at numerous metrics to understand overall performance and limits

- Outliers in main sims are analyzed in detail
- Sensitivity studies for specific phenomena used to stress the system and understand limits

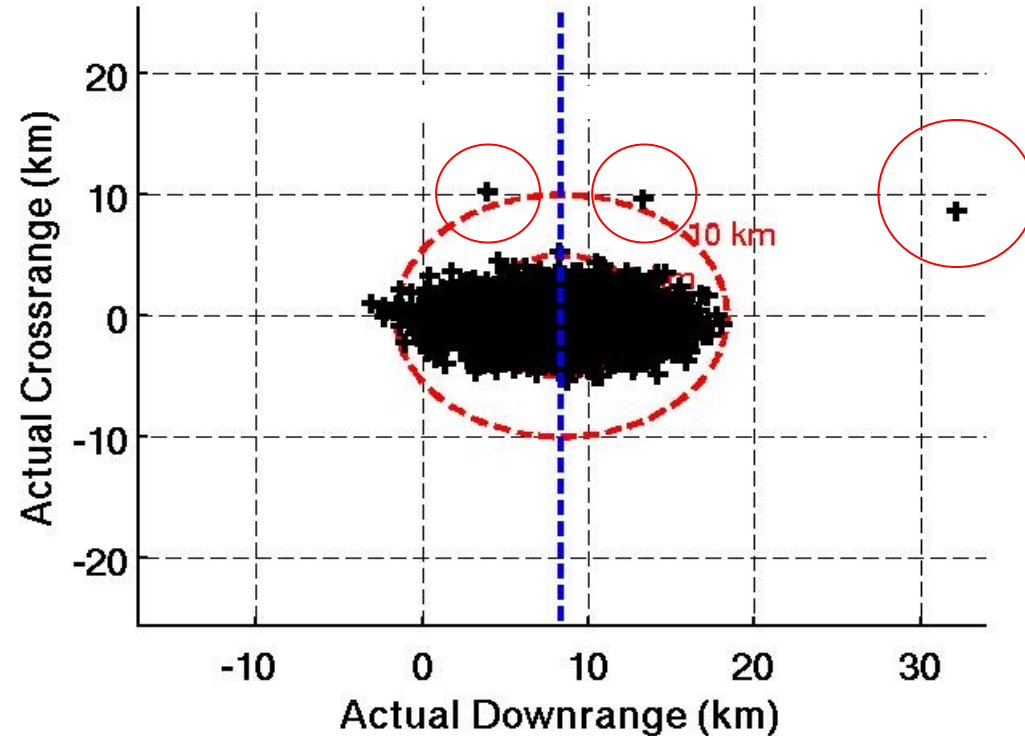

## MSL Trajectory Sim

- Outliers determined to come from large roll uncertainty, generating a persistent roll-torque
- Additional analysis showed that a  $3\sigma$  roll-torque was  $\sim 2x$  conservative modelling.

# Example: Pitch-Axis Monte Carlo



- Stress testing Monte Carlos increased the magnitudes of the aero/RCS interaction variables to well past the  $\pm 1.0$  values (corresponding to  $\pm 3\sigma$ ) about roll, pitch and yaw axes separately
- The controller is robust to interactions up to reversal for these cases.

$$A_{o,pitch} = \begin{bmatrix} 0 & 0 & 0 & 0 \\ w_{q,1} R_{q,1} & w_{q,2} R_{q,2} & w_{q,3} R_{q,3} & w_{q,4} R_{q,4} \\ 0 & 0 & 0 & 0 \end{bmatrix}$$

- Fuel usage is plotted against the sum of the interactions which together combine to produce an interaction about a principal axis
- Plots show where the “cliffs” occur for principle interactions. “Strong signal” indicates that cross-interactions are small.

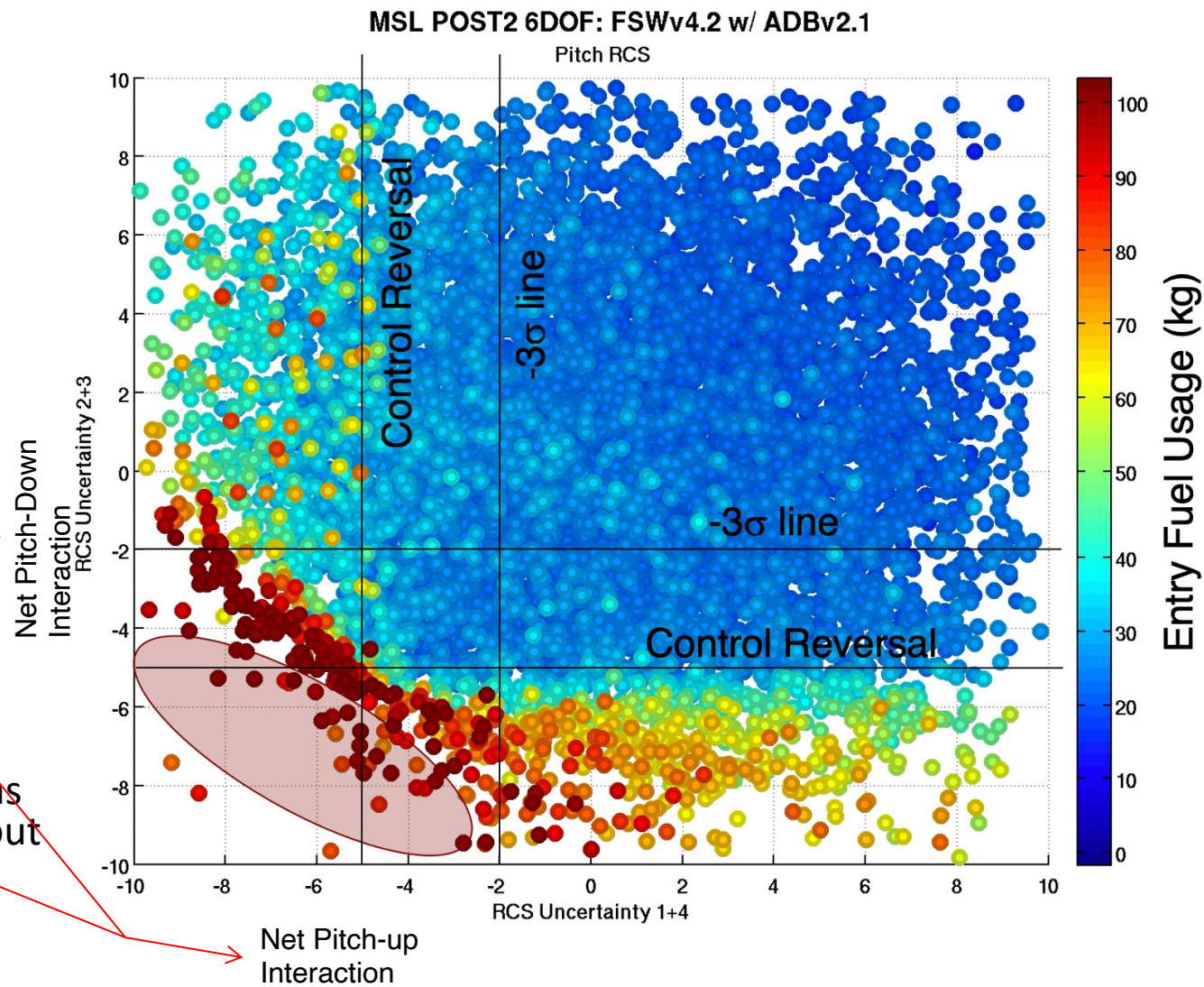

# Aerodatabase Sausage-making

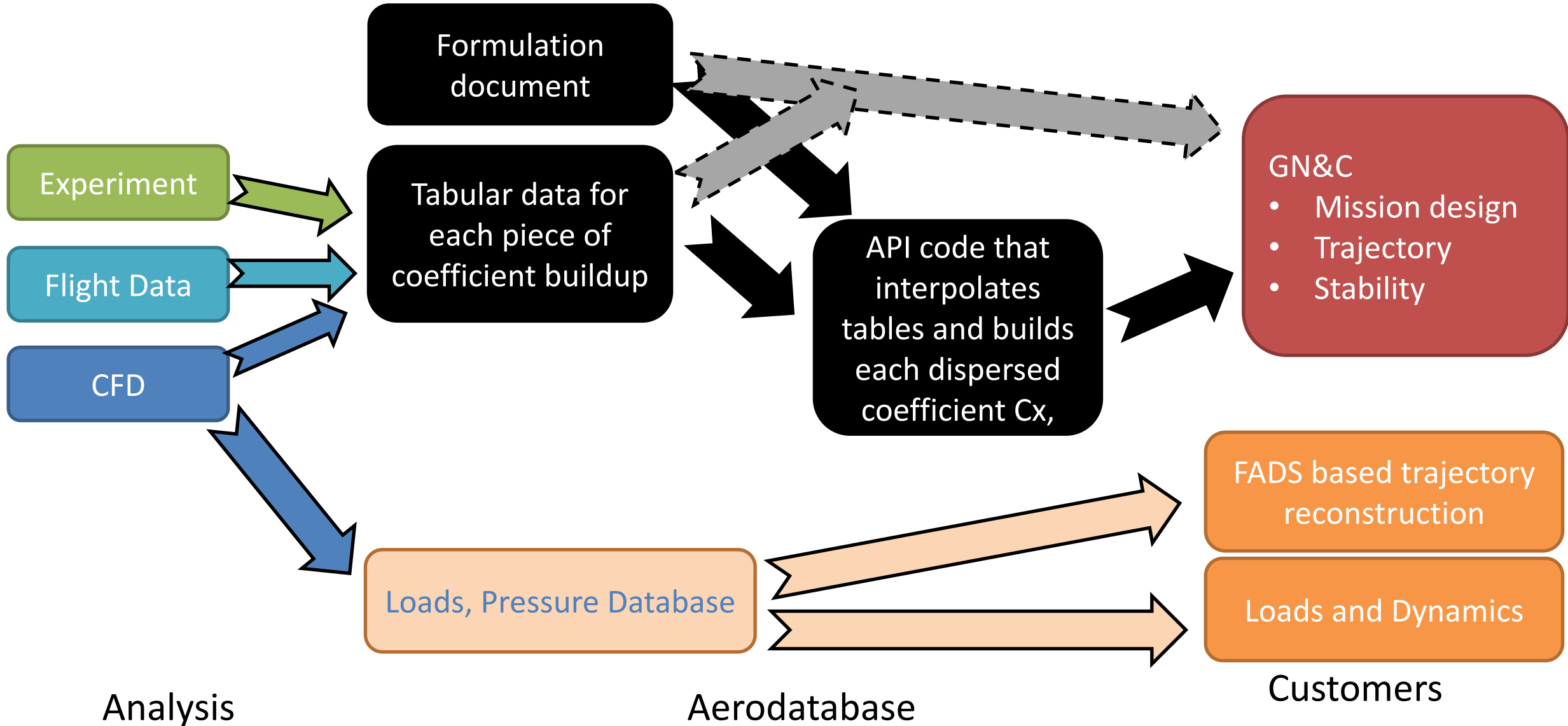

# Example Aerodatabase - LOFTID



## MAP DSMC

- atmospheric interface to rarefied/continuum overlap ( $Kn \sim 0.1$  to  $0.001$ )

## LAURA RANS (reacting gas)

- from rarefied / continuum overlap to hyper / supersonic overlap ( $M \sim 4$  to  $6$ )

## FUN3D RANS (perfect-gas)

- hyper / supersonic overlap down to subsonic

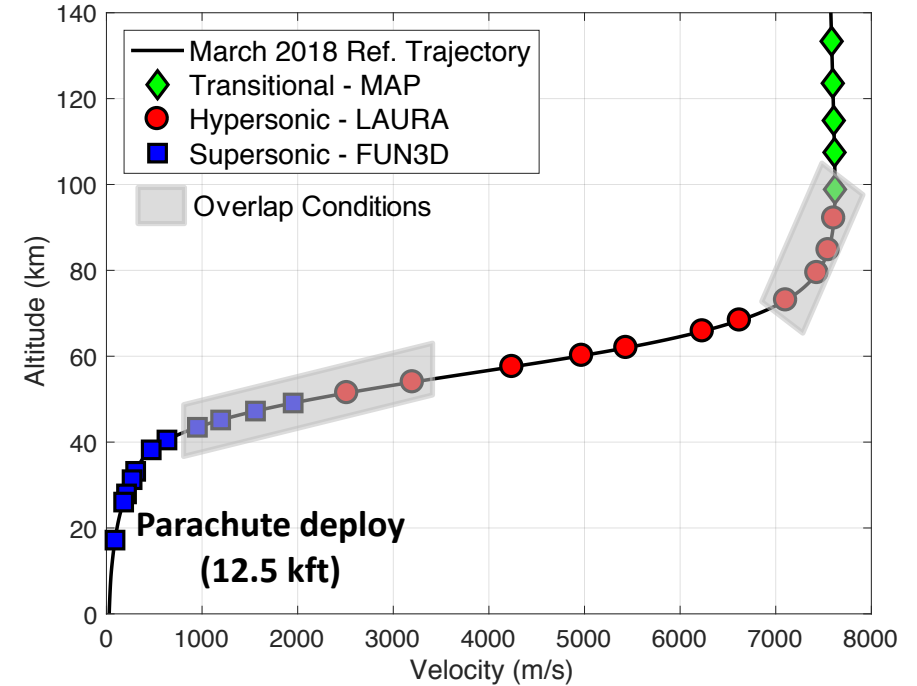
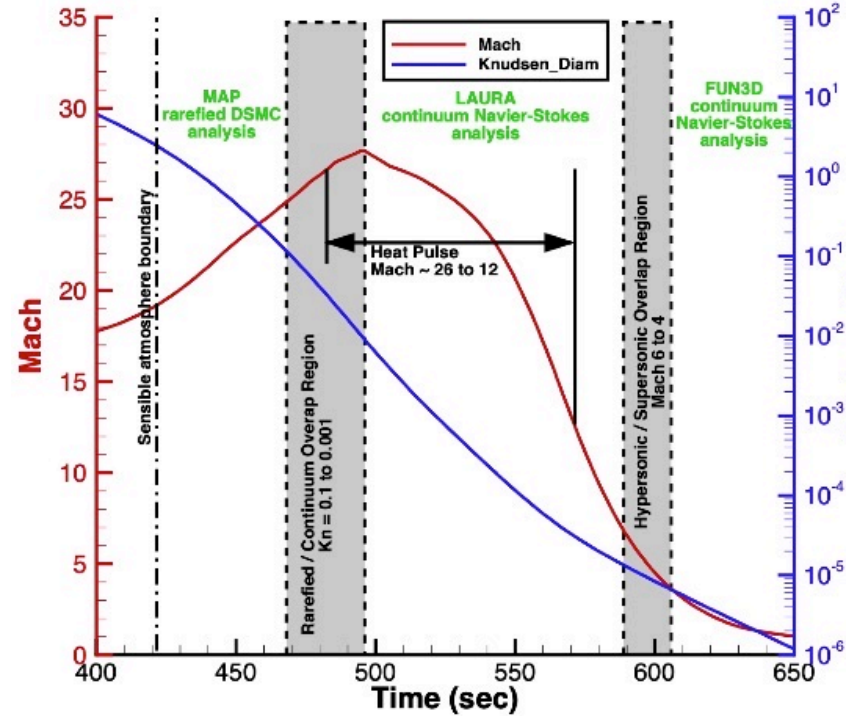

## Experimental data

- Help define uncertainty bounds (wake) and heating augmentation factors (scallop), as well as dynamic stability data

|               | Flight Regime  | Range   | Input Parameters     | Source      |
|---------------|----------------|---|----------------------|-------------|
| Non-continuum | Free-Molecular | $Kn > 3.018, 0^\circ \leq \alpha_T \leq 180^\circ$                          | $\alpha_T$           | DAC         |
|               | Transitional   | $0.00572 \leq Kn \leq 3.018, 0^\circ \leq \alpha_T \leq 8^\circ$            | $\alpha_T, Kn$       | MAP         |
| Continuum     | Hypersonic     | $M_\infty \geq 7.88$ and $Kn < 0.00572, 0^\circ \leq \alpha_T \leq 8^\circ$ | $\alpha_T, M_\infty$ | LAURA       |
|               | Supersonic     | $0.7 \leq M_\infty < 6.0, 0^\circ \leq \alpha_T \leq 20^\circ$              | $\alpha_T, M_\infty$ | FUN3D       |
|               | Mid-Subsonic   | $0.3 < M_\infty \leq 0.65, 0^\circ \leq \alpha_T \leq 20^\circ$             | $\alpha_T, M_\infty$ | IRVE-3 BR   |
|               | Low-Subsonic   | $M_\infty \leq 0.3, 0^\circ \leq \alpha_T \leq 70^\circ$                    | $\alpha_T$           | Moonrise WT |

# Example Aerodatabase - LOFTID



## Database implementation

- F90 subroutine
- Database tables hardcoded

## Database interpolation

- Continuum data sets linearly blended between breakpoints
- Bi-parabolic interpolation for table look-up for conditions above Mach 6.1
- Linear interpolation used for table look-up for conditions below Mach 6.1

## Uncertainties

- Based on IRVE-3, rigid vehicle implementation
- All static aero uncertainties uncorrelated
- Normal distribution used to disperse static aero, except  $C_{ll}$
- Uniform distribution used to disperse  $C_{mq}$ ,  $C_{nr}$  and  $C_{ll}$

| Flight Regime                    |             | $C_A$      | $C_Y$                | $C_N$                | $C_{ll}$                  | $C_m$                 | $C_n$                 |
|----------------------------------|-------------|------------|----------------------|----------------------|---------------------------|-----------------------|-----------------------|
| Free-Molecular /<br>Transitional | $Kn > 1000$ | $\pm 5\%$  | $\pm 0.01, \pm 20\%$ | $\pm 0.01, \pm 20\%$ | $\pm 1.24 \times 10^{-6}$ | $\pm 0.005, \pm 20\%$ | $\pm 0.005, \pm 20\%$ |
| Hypersonic                       | $M > 10$    | $\pm 3\%$  | $\pm 0.01, \pm 20\%$ | $\pm 0.01, \pm 20\%$ | $\pm 1.24 \times 10^{-6}$ | $\pm 0.003, \pm 20\%$ | $\pm 0.003, \pm 20\%$ |
| Supersonic                       | $M < 5$     | $\pm 10\%$ | $\pm 0.01, \pm 20\%$ | $\pm 0.01, \pm 20\%$ | $\pm 1.24 \times 10^{-6}$ | $\pm 0.005, \pm 20\%$ | $\pm 0.005, \pm 20\%$ |

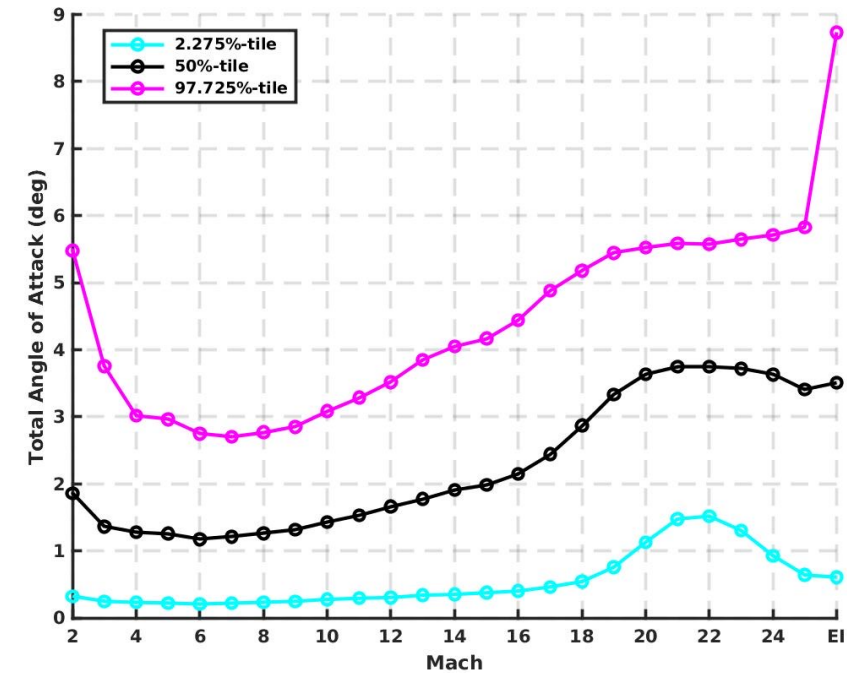
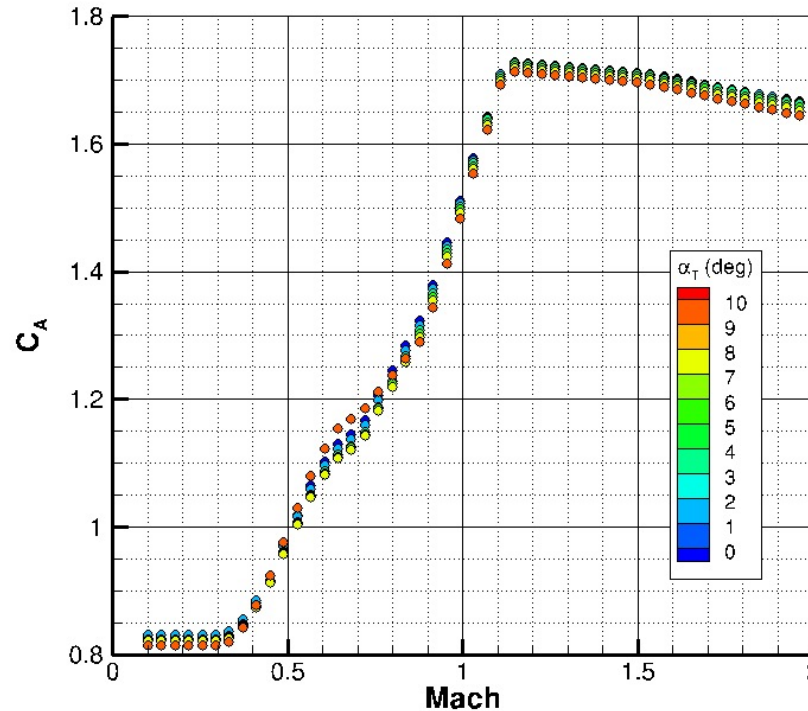

# Example Aerodatabase - Orion



- Orion aerodatabase covers wide range of possible missions, trajectories
  - Guided, ballistic entry
  - Aborts – low Reynolds number
- Aerodatabase API
  - written in C
  - Linearly interpolates database tables
    - Over 200 tables currently
  - Matlab wrapper
  - Python-based development tool

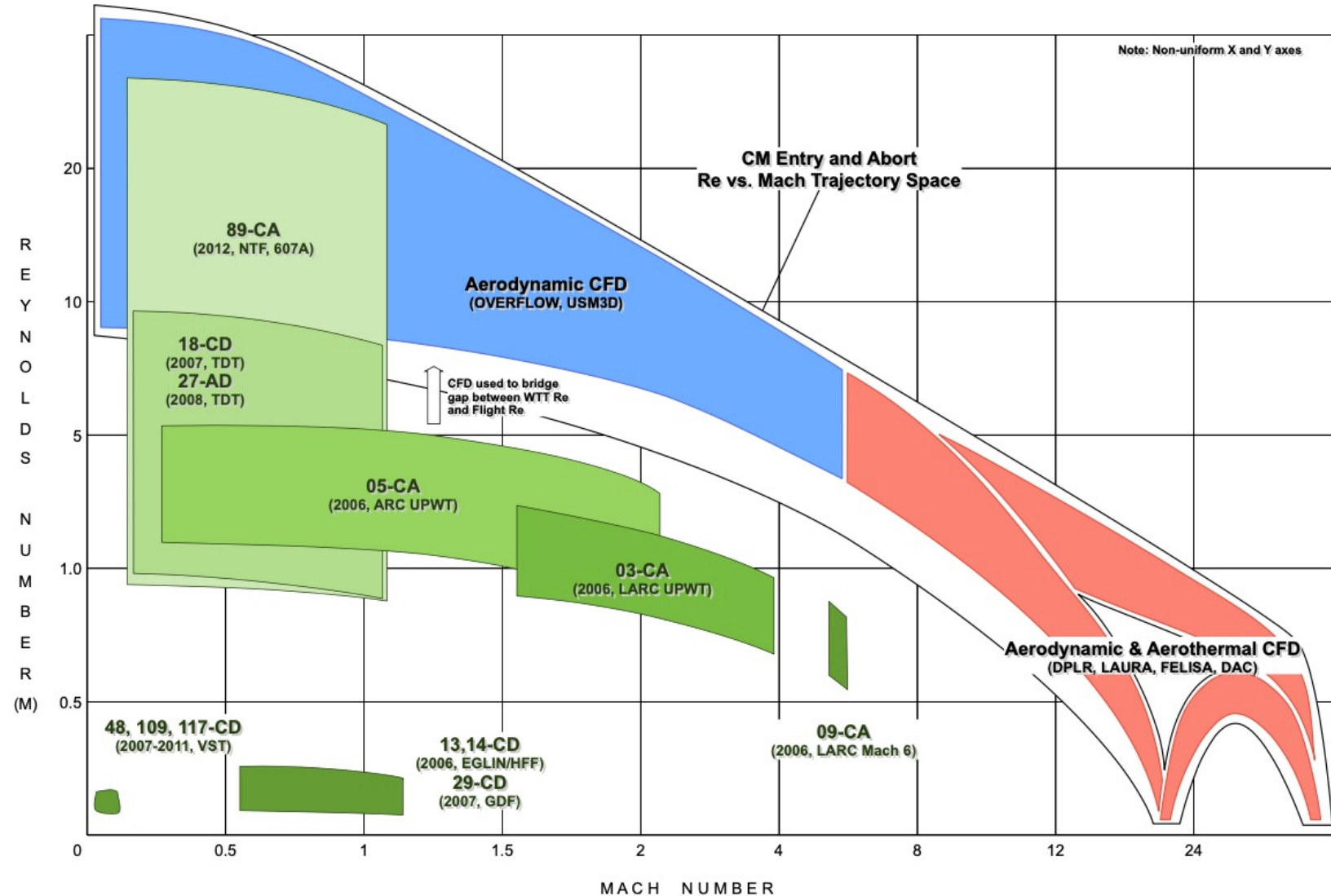

# Example Aerodatabase - Orion



## Primary CFD Set, OVERFLOW

- IDAT geometry, 30° backshell
- $0.3 \leq M \leq 8.0$ , Flight  $Re_D$  only

## Secondary CFD sets, for uncertainties

- $0.2 \leq M \leq 1.1$ , WT and Flight  $Re_D$  baseline 32.5° backshell, OVERFLOW
- USM3D, selected Mach numbers, IDAT

## Aerothermal CFD Set

- LAURA, DPLR – viscous, reacting gas air chemistry, laminar and turbulent
- $M > 2$ ,  $147^\circ \leq \alpha \leq 170^\circ$  only
- Baseline and IDAT geometries

## 05-CA, Ames Unitary Plan WT

- $0.3 \leq M \leq 2.5$ ,  $140^\circ \leq \alpha \leq 170^\circ$
- Max  $Re_D = 5.3 \times 10^6$ , 7% model

## 03-CA, Langley Unitary Plan WT

- $1.6 \leq M \leq 4.0$ ,  $140^\circ \leq \alpha \leq 170^\circ$
- Max  $Re_D = 1.5 \times 10^6$ , 3% model

## 09-CA, Langley Aerothermal Lab, Mach 6

- $M=6.0$ ,  $0^\circ \leq \alpha \leq 180^\circ$

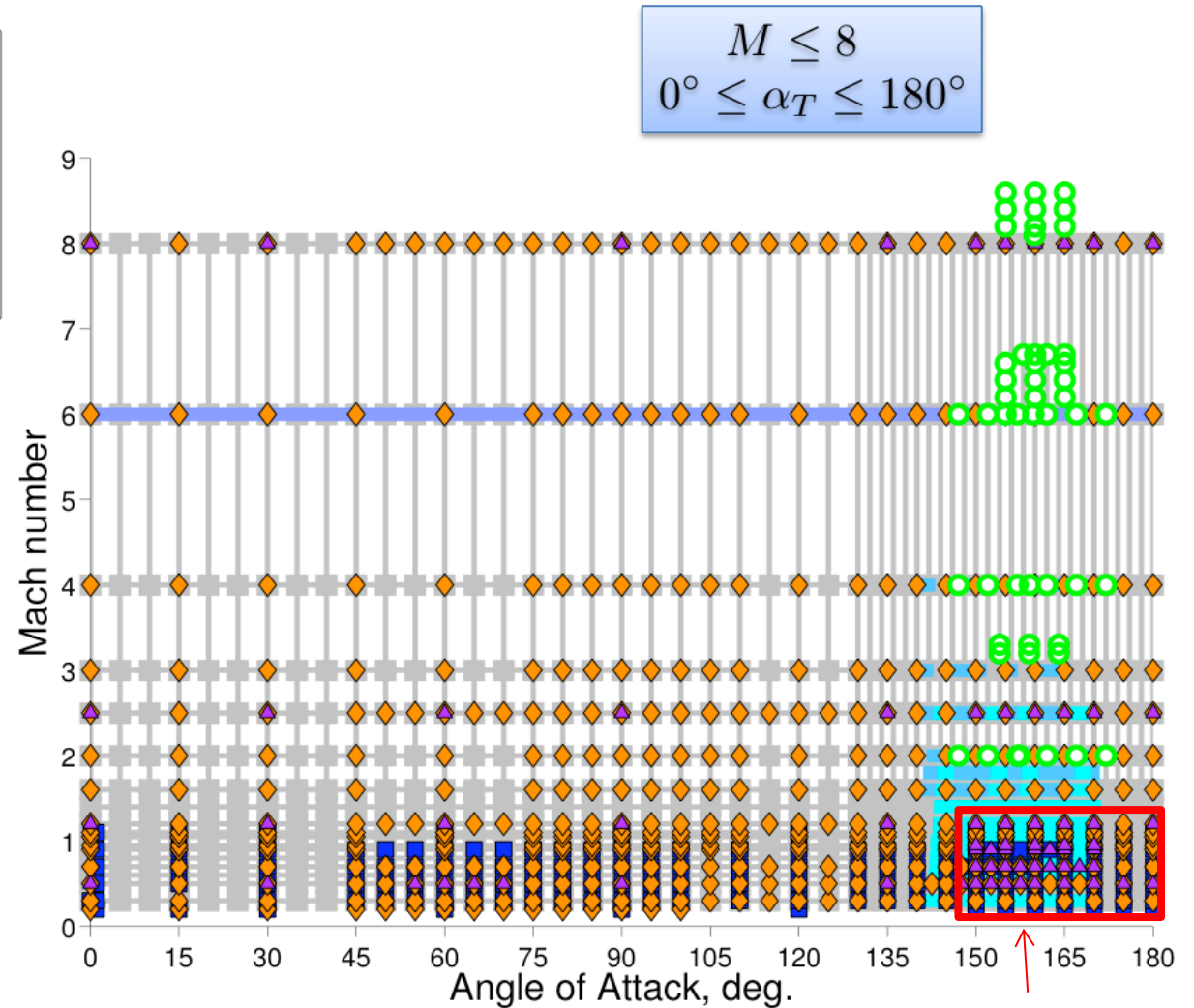
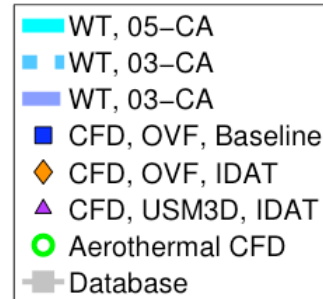

WT dominant region

# Example Aerodatabase - Orion



Buildup plots show relative importance of the uncertainty terms.

- For  $M = 0.5$ 
  - RSS term dominated by WT-to-CFD term
  - Reynolds number coverage term also large
  - IDAT coverage is noticeable
  - CFD variations around  $60^\circ$  lead to high error.

- MI\*RSS + coverage terms
- IDAT coverage
- Asymmetry coverage
- Altitude variation
- Lam/turb variation
- Real Gas variation ( $M > 2$ )
- Re variation
- RSS term
- ⋯ WT accuracy
- ⋯ CFD accuracy
- ⋯  $\Delta$  WT-CFD

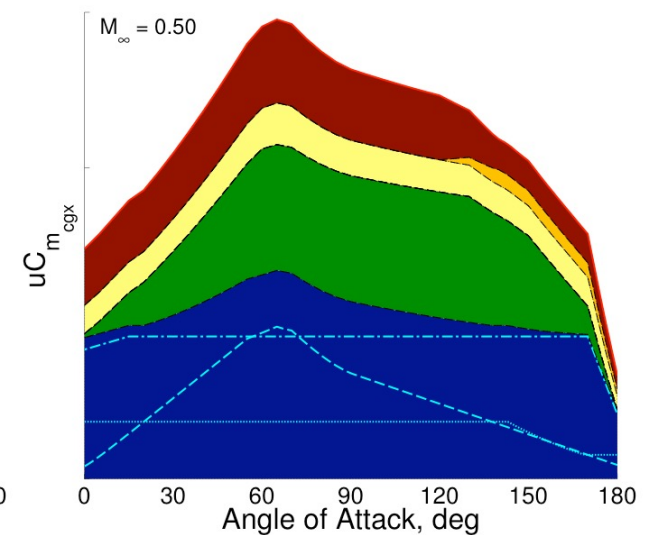
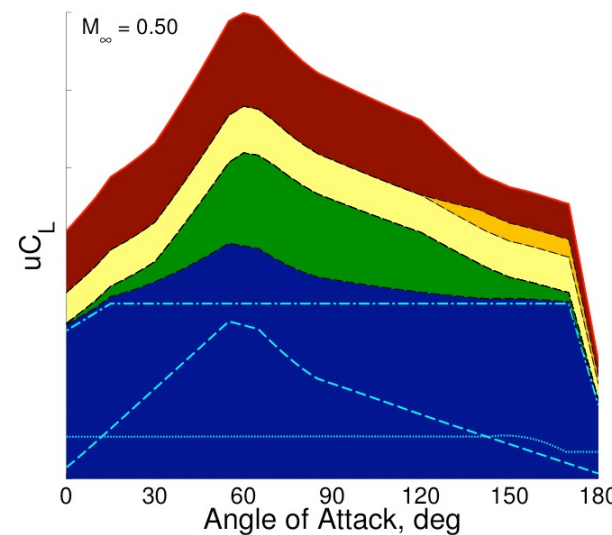
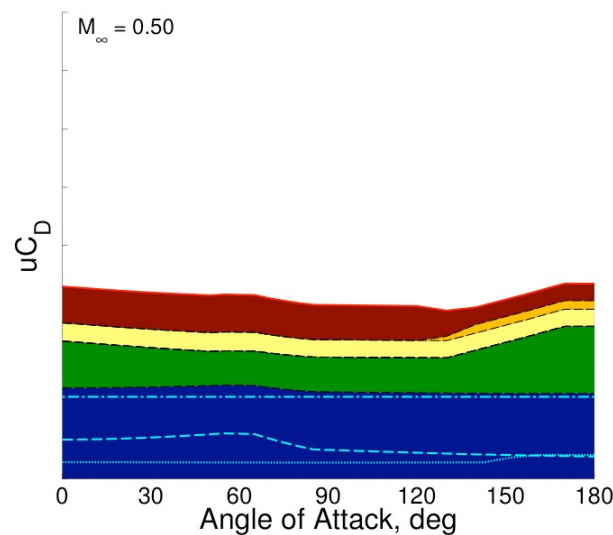

# Example Aerodatabase - Orion



- Typical plots to visualize database
- Uncertainties cover most data, even though CFD not used in trim region
- Decrease in  $uC_L$ ,  $uC_m$  near  $\alpha = 180^\circ$  evident

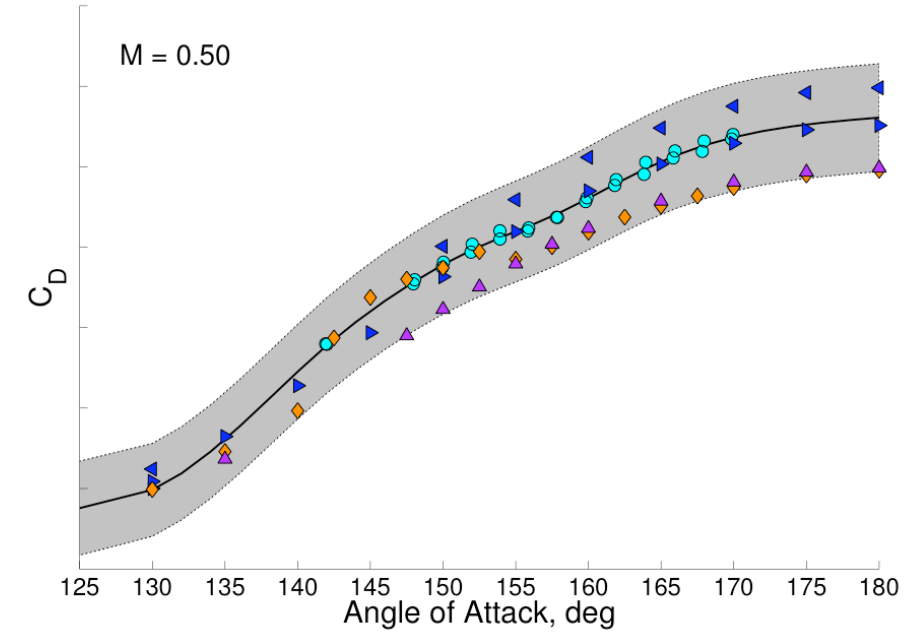
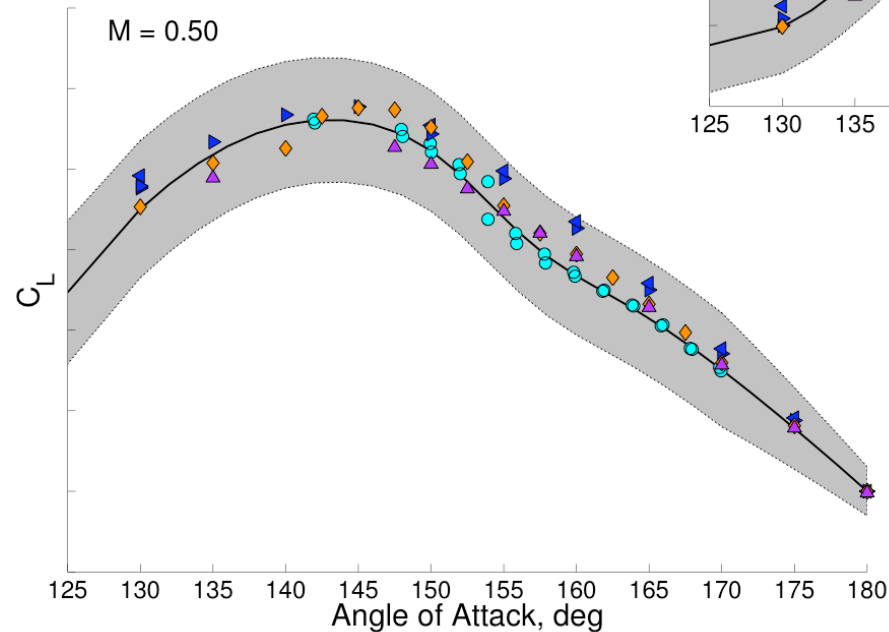
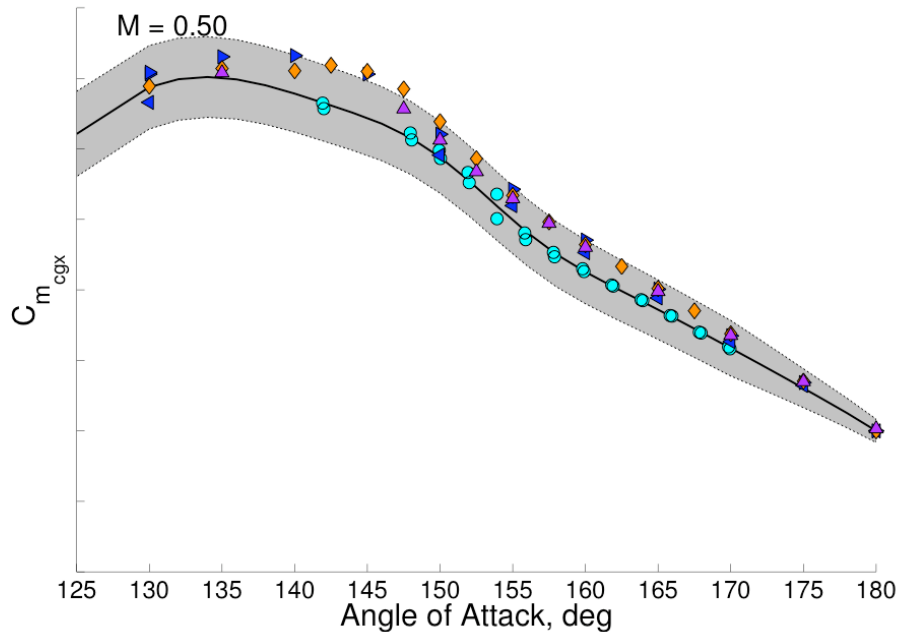

- Database Nominal
- ▭ Database Uncertainty
- WT 05-CA data
- ▲ CFD, Baseline, OVF, Flight  $Re_D$
- ▲ CFD, Baseline, OVF, WT  $Re_D$
- ◆ CFD, IDAT, OVF
- ▲ CFD, IDAT, USM3D

# Research Topics – Machine Learning



- Machine learning / data fusion techniques offer improvements in how we blend datasets and propagate uncertainties.
- Aerofusion team is using MSL and Orion data to explore various methodologies
- Orion is expecting to use techniques for at least some of an upcoming database release.

The AEROFUSION team was selected to look at leveraging and extending data science advances to modernize the aerodynamic model data fusion process for the Mars EDL application- specifically large payload and manned missions that require novel aero shells.

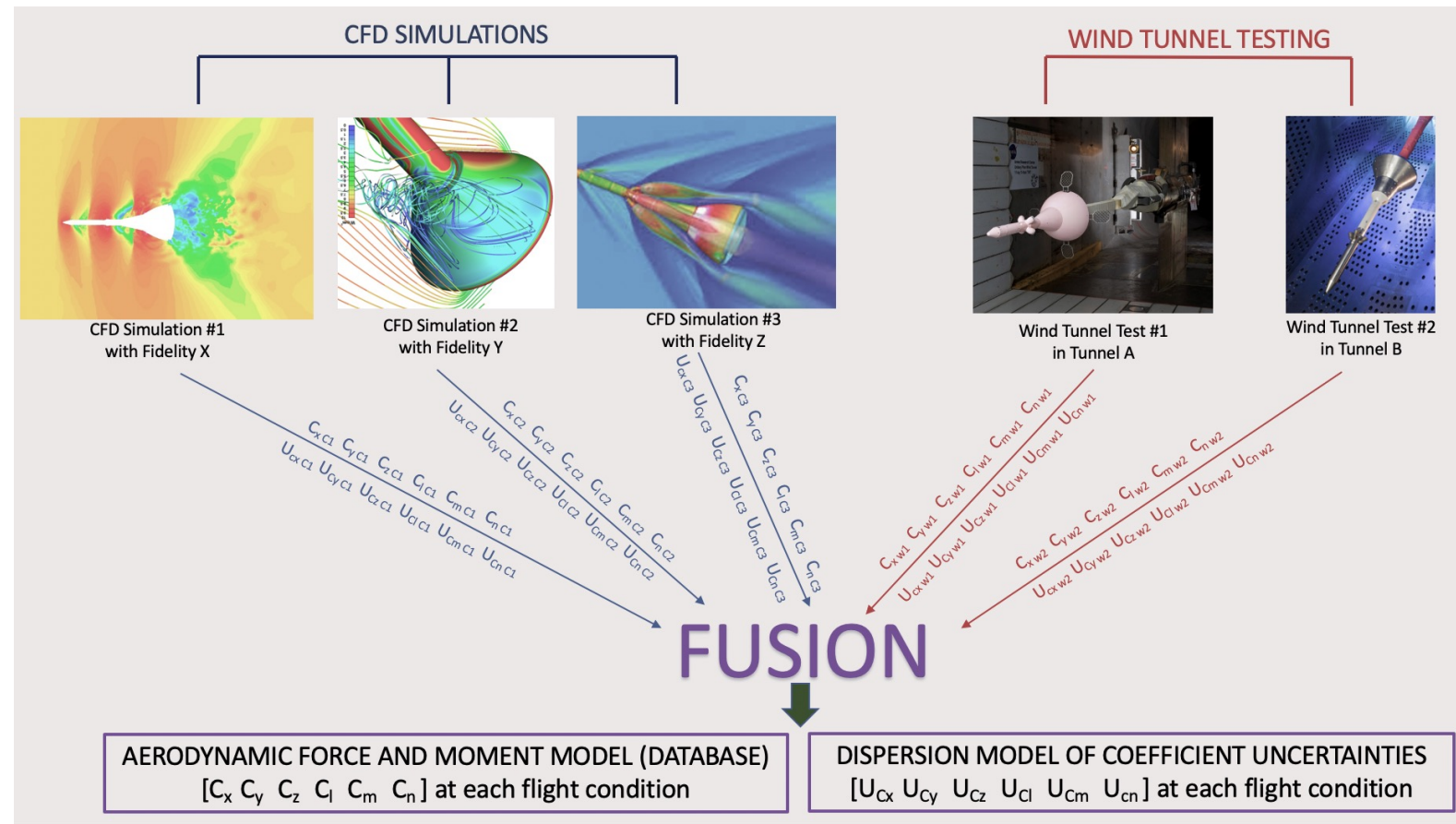

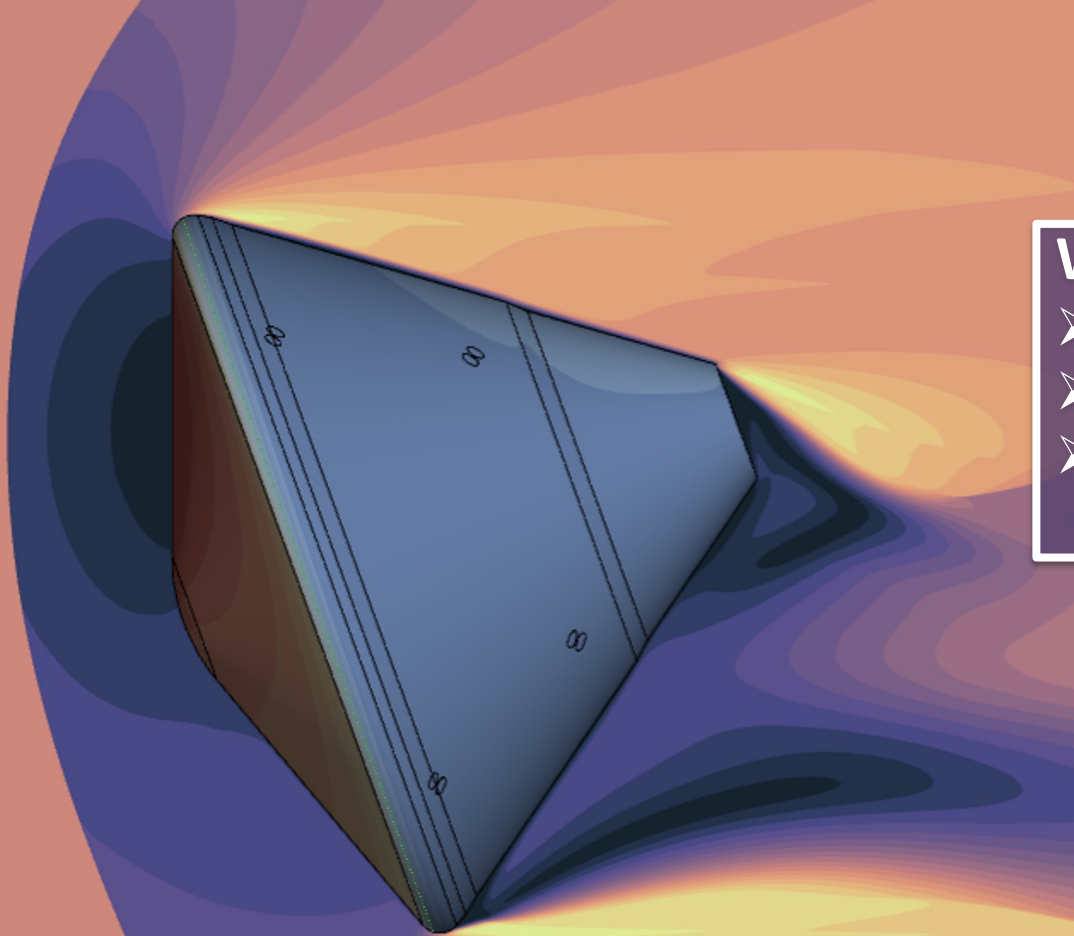

## What we covered today

- How is aerodynamic modeling used in EDL?
- How do we develop aerodynamic predictions?
- How do we communicate aerodynamics to the rest of the EDL disciplines?

## Analysis Challenges

- Improved physics (chemistry, turbulence) in CFD
- Computational expense
- Decreased uncertainties



## Rewards

- Higher precision landings
- Larger landed mass.
- Missions we couldn't do before

# Collaborators



- Ashley Korzun – LaRC AEFSB, EDL, SRP, FUN3D CFD
- Adam Wise – LaRC AB, LAURA and FUN3D
- Tuan Troung – JSC EG3, Orion Aerosciences (aero)
- Mark Schoenenberger – LaRC AEFSB, Mars aero guru
- Robert Childs – Ames, Capsule aero CFD and turbulence modeling
- Greg Brauckman – LaRC AB, Experimental Aero, Orion testing, STS-1 testing
- Bruce Owens – LaRC, Dynamic aero testing (TDT, spin tunnel)
- Joe Brock – Ames, freeflight CFD with US3D
- Adam Amar – JSC EG3, Orion Aerosciences (aerothermal)
- Derek Liechty – LaRC AB, DSMC
- Clark Pederson – LaRC AB, MSL, turbulence
- Vic Lessard – LaRC AB, Orion aerothermal, LAURA and FUN3D CFD
- Alireza Mazaheri – LaRC AB,
- Bill Wood – LaRC AB, LAURA and FUN3D CFD, SRP
- Bil Kleb – LaRC AB, Computational aerothermal ST and FUN3D S2S guru
- Neil Cheatwood – LaRC AEFSB, EDL, LOFTID
- Francisco Canabal – MSFC, SRP

EXPLORE  
MOON<sub>to</sub>MARS





# BACKUP

# Acronyms



- ADEPT – Adaptable, Deployable Entry and Placement Technology
- CFD – Computational Fluid Dynamics
- DES – Detached Eddy Simulation
- ESM – Entry Systems Modeling
- FADS – Flush Air Data System
- HIAD – Hypersonic Inflatable Aerodynamic Decelerator
- JI – Jet Interaction
- LOFTID – LEO Flight Test of an Inflatable Decelerator
- RCS – Reaction Control System
- SRP – Supersonic Retropropulsion
- TPS – Thermal Protection System
- WT – Wind Tunnel

# Entry profiles for Orion

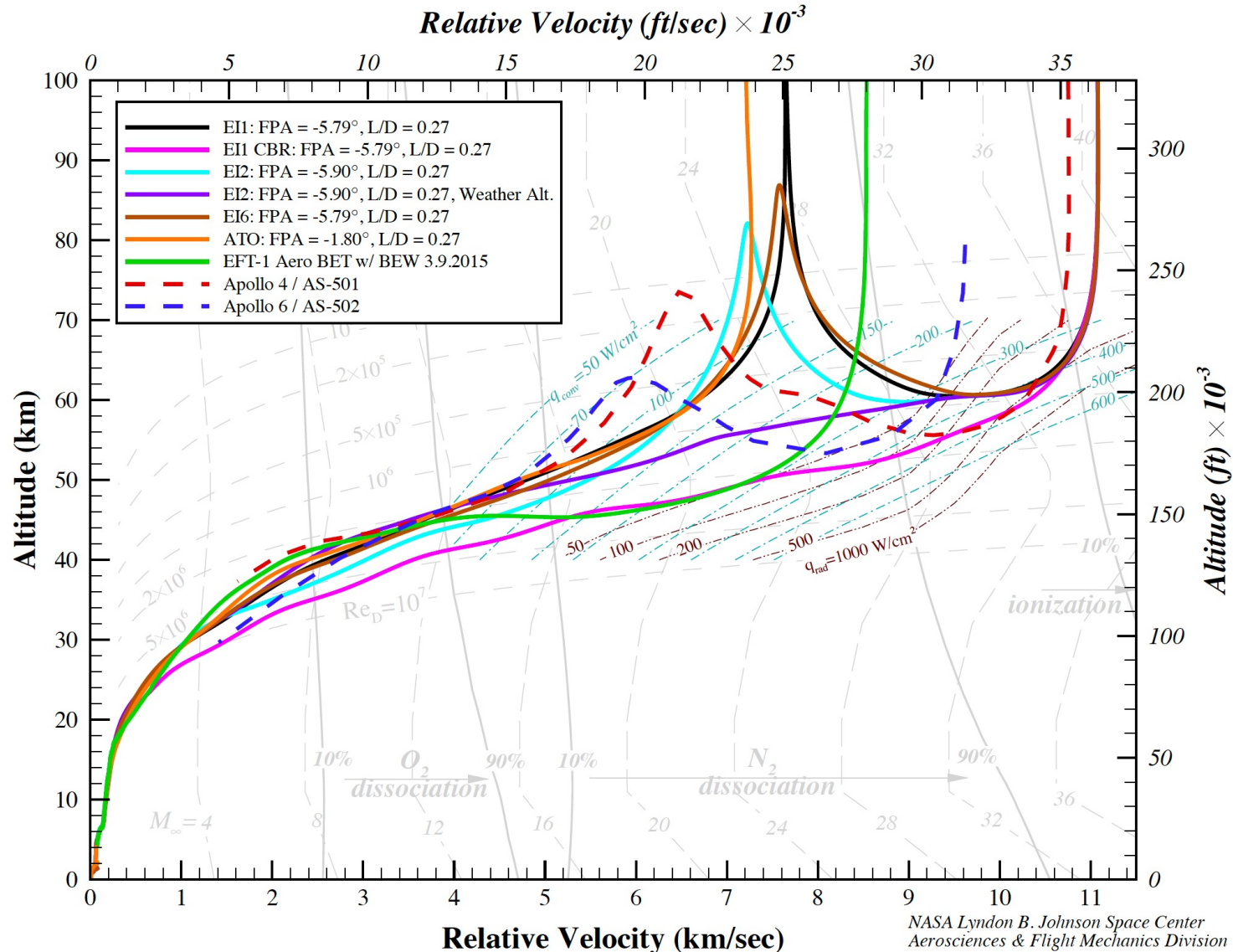

# What is DSMC?

- Direct Simulation Monte Carlo
  - Developed by Dr. Graeme Bird in the '60s
  - Stochastic model of individual simulated particles and their physics
    - Each DSMC 'particle' represents many real particles
  - Probabilistic approach
    - Simplified models use cross sections determined from experiments or analytic results

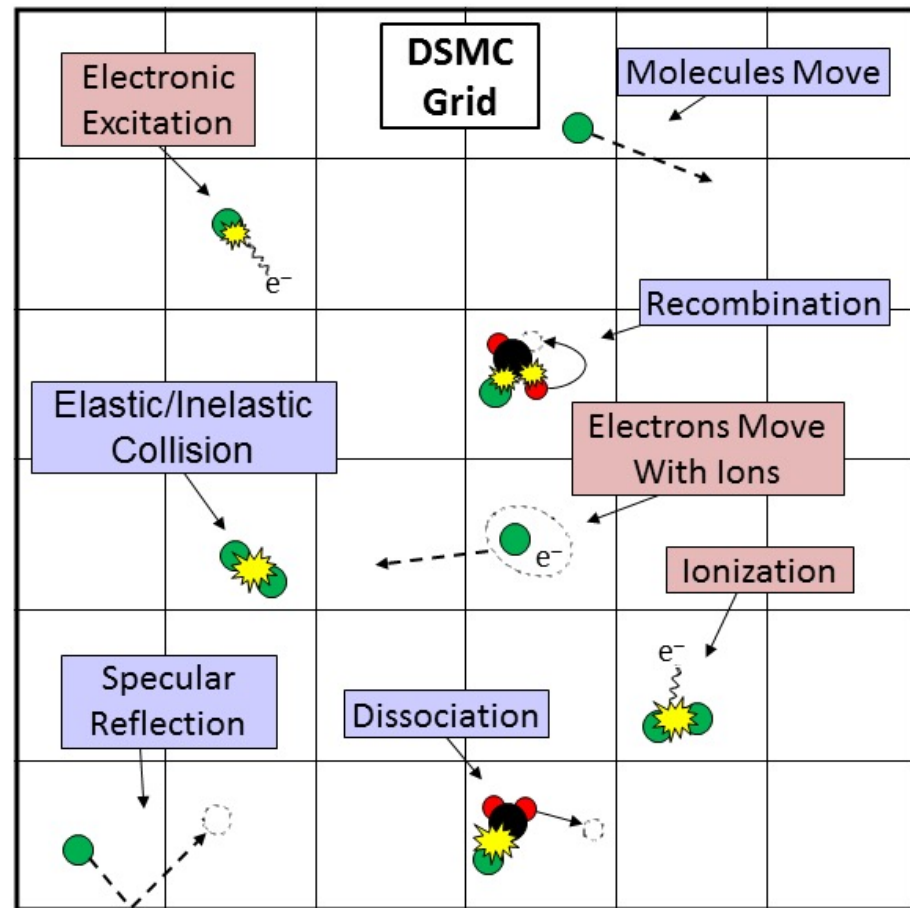
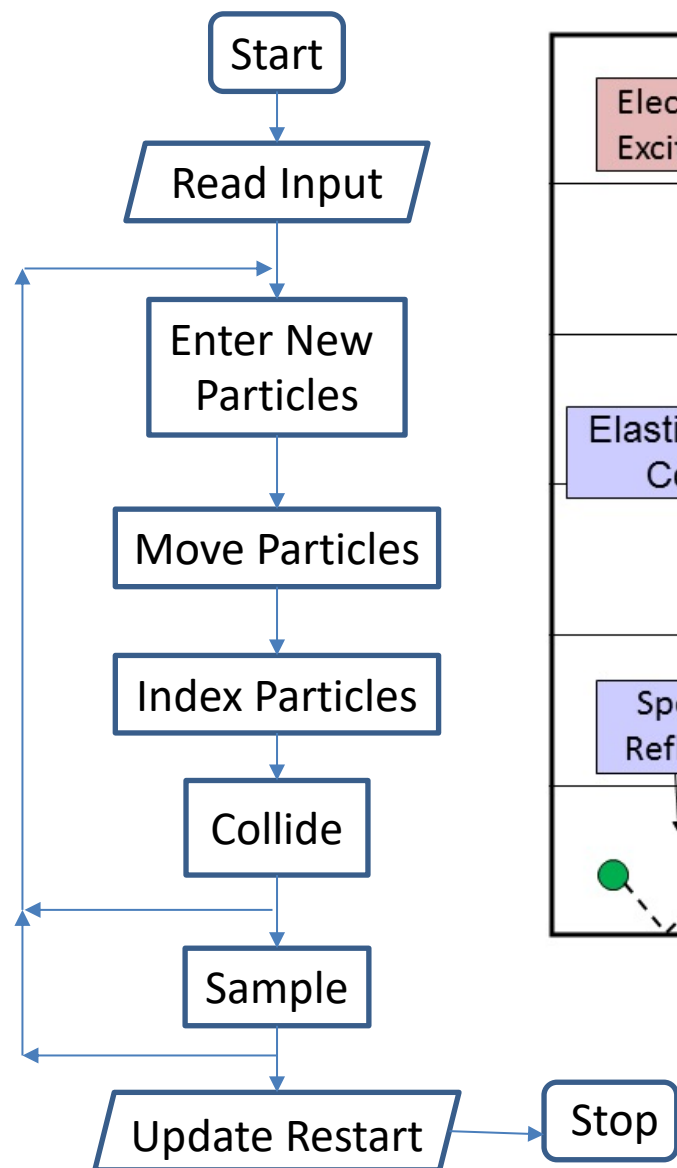

# MAP: Multiphysics Algorithm with Particles



- MAP is a 0D/2D/Axi/3D adaptive Cartesian implementation
- Dynamic adaptation
  - Flow field grid – fraction of the local mean free path
  - Time step – local mean collision time or transit time
  - Surface temperature – radiative equilibrium
- Grid
  - Morton Octree Cartesian grid for the flow field
  - Unstructured triangular surface grid separate from flow field
- Gas model
  - Internal degrees of freedom – rotational, vibrational, electronic
  - Chemistry – gas phase and surface
  - Charge neutral ionization

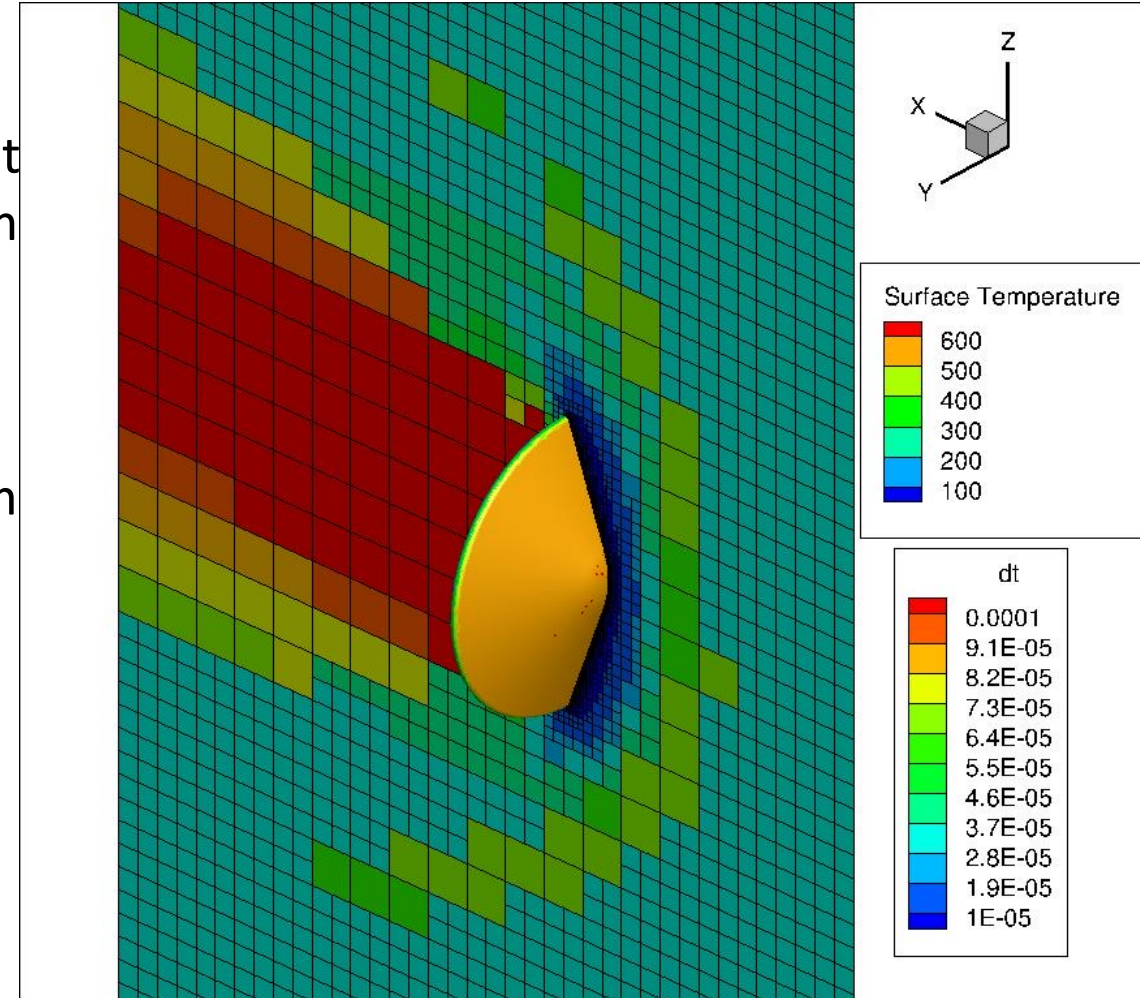

# CFD Team Tools: Blurring the Lines



- Continually pushing to overlap CFD and DSMC
  - Updating particle properties to reproduce CFD curve fits
    - Earth – 5- and 11-species (neutral/ionized)
    - Mars and Venus – 18-species (ionized)
    - Titan – 13- and 19-species (neutral/ionized)
  - Inclusion of same physics
    - DSMC didn't generally include electronic energy and ionization
    - Radiation
  - Hybrid DSMC/CFD
    - One-way coupling is easy... Two-way not so much!
    - To get valid solutions in all parts of the flow field, we will have to come up with a two-way coupled solution

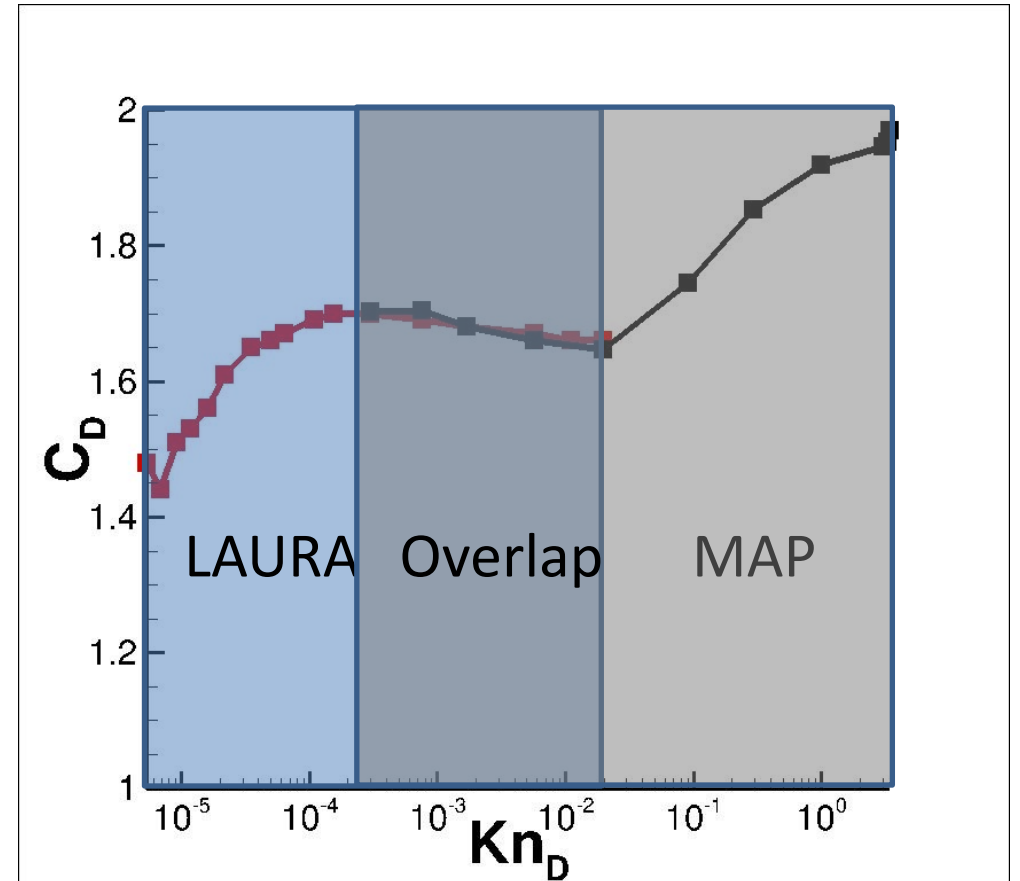

# Uncertainty Development – Orion



## Orion: individual contributors to error are combined

- Each analysis has associated uncertainties
- Database model has additional uncertainties
- Not shown, we always have a ‘flight’ term that covers how well our models are expected to simulate flight

## Based in statistical process control theory

- Variational terms are RSS’d
- Coverage terms are added
- Multipliers used for poorly quantified terms

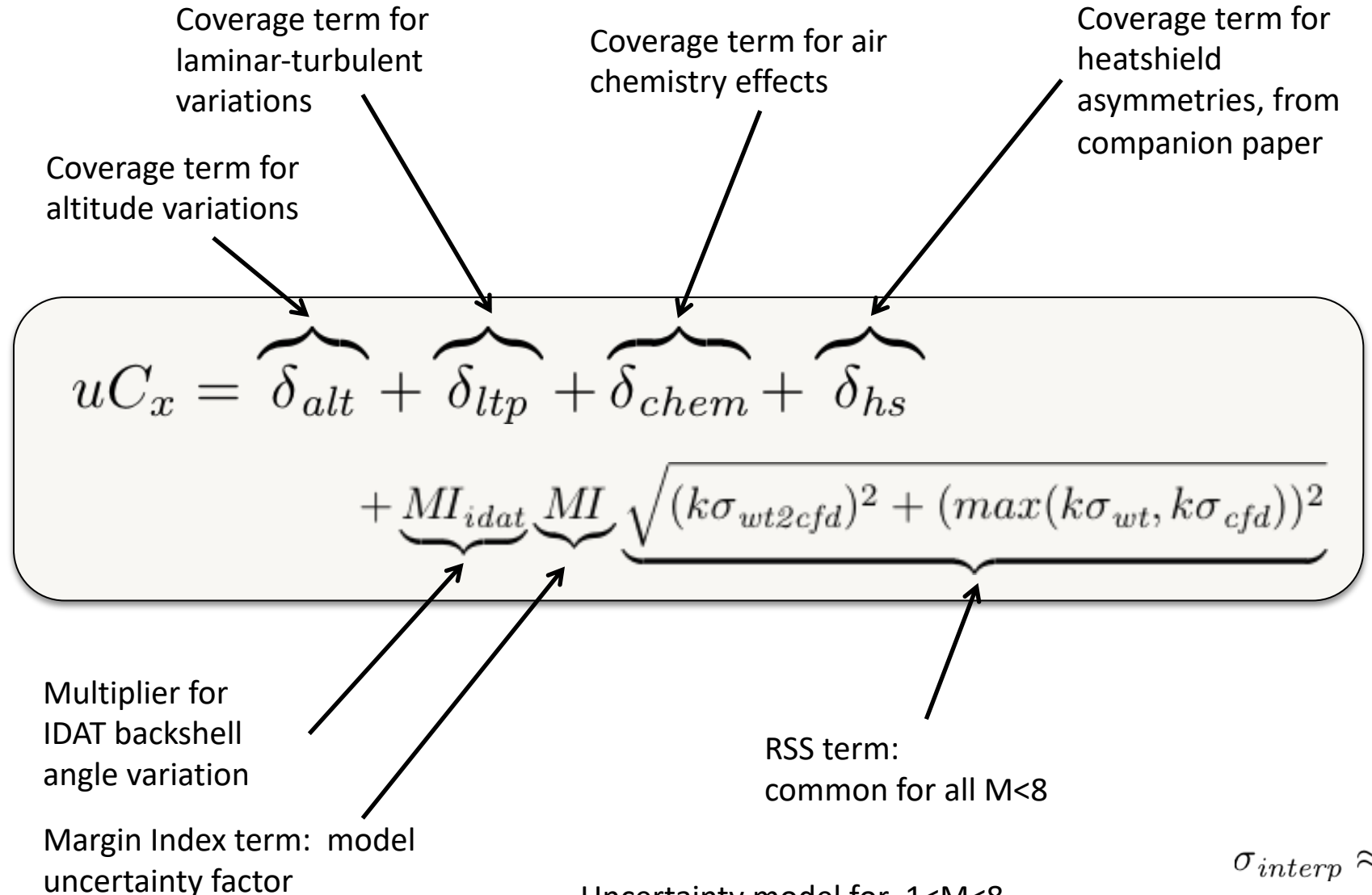

$$\sigma_{interp} \approx 0$$

# Uncertainty Development

Uncertainty model development strategies vary more than the nominal aero analysis

- For Orion, individual contributors to error are combined
  - Based in statistical process control

Margin Index term:  
model uncertainty factor

Heatshield  
asymmetry term

RSS term  $k = \sqrt{3}$   
Coverage term for  
uniform distribution

$$uC_x = \delta_{hs} + MI \sqrt{(k\sigma_{grid})^2 + (k\sigma_{ltp})^2 + (k\sigma_{ks})^2}$$

CFD accuracy term

Laminar-turbulent pair  
(ltp) variation

Combined altitude and  
code-to-code variation

$$k\sigma_{ks} \approx \sqrt{(k\sigma_{alt})^2 + (k\sigma_{c2c})^2}$$

