

# **A History of Jet Noise Research at the National Aeronautics and Space Administration**

Brenda S. Henderson,<sup>1</sup> Dennis L. Huff<sup>2</sup>

<sup>1</sup> *NASA Glenn Research Center, MS 54-3, Cleveland, OH 44135, USA*

<sup>2</sup> *NASA Glenn Research Center, MS 54-3, Cleveland, OH 44135, USA*

## **ABSTRACT**

This paper reviews jet noise research conducted at the National Aeronautics and Space Administration (NASA) from the early 1950s to the present day. Research conducted by NASA's predecessor, the National Advisory Committee for Aeronautics (NACA), and early years of NASA focused on turbojet noise, where a common approach for reducing jet noise was to limit the jet exit velocity to speeds that provided acceptable noise levels. Suppressors tested during this time resulted in thrust losses that were too severe to be implemented. With the introduction of turbofan engines in the 1960s, NASA shifted research to programs for both subsonic and supersonic aircraft applications with specific noise reduction goals. Subsonic research focused on increasing the bypass ratio of the engine to reduce the jet exit velocity of the core exhaust and adding mixers to the dual exhaust streams. Advances in computational methods improved aerodynamic designs and jet noise prediction tools. Supersonic applications proved to be more troublesome as programs aimed at large commercial transports required higher specific thrust engines. Changing the engine cycle to reduce jet noise was not compatible with mission range and speed requirements. Research for supersonic commercial aircraft remains an area of interest today at NASA.

## I. INTRODUCTION

Jet noise became a problem for aircraft as soon as turbojets were introduced in the 1940s. Communities were suddenly experiencing a loud, low-frequency rumbling sound around airports from commercial and military transports instead of propeller noise. Research at the National Advisory Committee for Aeronautics (NACA) was expanded to explore ways to reduce jet noise. Work was performed at the Langley, Lewis and Ames Research Centers. At a public open house in June 1945 shortly after the opening of the Lewis Research Center, visitors "... experienced the earsplitting roar of a ramjet and other jet propulsion performances...."<sup>1</sup>. This marked what has become a long-term commitment to jet-noise research that remains today as jet noise continues to draw noise complaints around airports and restricts expansion of commercial aviation. Jet noise has also become a serious issue around military air bases.

The most successful way to reduce jet noise is to reduce the velocity of the jet. Early turbojets and today's tactical aircraft have high specific thrust engines and, therefore, high jet velocity relative to modern high-bypass ratio turbo-fan engines. Much of the jet noise reduction has come from modifications to the engine cycle evolving from turbojets to turbofans with increasing bypass ratios. Fortunately for commercial subsonic transports, this has also been the trend for higher efficiency engines with lower fuel burn. For applications requiring higher specific thrust engines such as supersonic transports, the remaining challenge is to identify ways to reduce jet noise with acceptable performance impact.

Mixing devices were originally explored as a means to reduce jet velocity and, therefore, jet noise. These devices have been found to alter the spectral characteristics of jet noise often with reductions in low frequency levels at the expense of increases in high frequency levels. For some types of devices such as mixer-ejectors, acoustic treatment has been used to address the unwanted

high-frequency noise. However these types of devices add to the size, weight, and complexity of the system. Thrust losses must be minimized before any consideration for application. Early mixing devices significantly reduced jet noise but also decreased engine thrust. Today, computational tools are used to help with designs that minimize thrust loss for exhaust systems.

This paper reviews the jet noise research conducted at National Aeronautics and Space Administration (NASA) starting with the work performed at NACA. The paper frames the jet noise problem and the reasons for NACA and NASA to get involved with fundamental research. A chronological history of programs and projects sponsoring jet noise research is presented and divided into sections for subsonic and supersonic aircraft applications. Jet noise prediction development is highlighted in a separate section since it spans subsonic and supersonic vehicles, but only a brief discussion is included to show the range of fidelity for empirical and computational methods. The historical perspective shows the importance of properly scaling model tests, including forward flight effects, and conducting careful flight tests for comparisons between prediction methods and experimental data. One of the purposes of this paper is to document progress and lessons learned from the past in hopes that future research will benefit from the compilation of references and documentation of previous accomplishments. Due to NASA's significant investment in jet noise research over 70 years, it is not possible to cite all work, although an effort has been made to cite significant contributions over a broad range of jet-noise topics. Emphasis has been placed on early work rather than research conducted over the past 10-20 years, since recent work is readily available and reported by the current aeroacoustic workforce.

## **II. THE BEGINNING – NACA**

The predecessor of NASA was NACA, founded by Congress on March 3, 1915. While the United States was first in powered, heavier-than-air, flight with the Wright Flyer in 1903, the country lagged Europe in aeronautic accomplishments by the beginning of World War I. In an effort to

bridge the gap, the advisory committee of 12 members was founded with the charter, “to supervise and direct the scientific study of the problems of flight with a view to their practical solution.” The voluntary committee members met semiannually to define problems of interest. The study and solution of those problems were originally undertaken by other entities such as government agencies or university laboratories. The original legislation did not call for a national laboratory as there was concern that such a move with the outbreak of World War I could compromise America’s stance on neutrality. However, the general language of the charter did not preclude the creation of a national laboratory, and construction of the Langley Memorial Aeronautical Laboratory began in 1917. It was dedicated on June 11, 1920 and commenced operation with a staff of 11 people.<sup>2</sup>

The first annual report from the committee defined general problems with airplane stability, air speed meters, efficient wing sections, and high-powered motors. Additionally, the report defined physical problems, which included material concerns, size limitation, and causes of accidents, to name a few. In the first few years of NACA, the problems of interest covered a vast swath of aviation and included cadet training as the United States entered World War I, insurance for aviators, mapping from airplanes, aerial mail routes, and landing fields for transient aviators.<sup>3-5</sup> Obviously, acoustics was not of any concern at this early point in aviation.

In 1939, NACA decided to add a new laboratory to supplement the Langley Memorial Laboratory. Moffett Field (now Ames Research Center) in California was selected due in part to the aircraft industry in that state. As World War II approached, there was concern that the US was falling behind England and Germany in engine developments, and a Special Committee on Aeronautical Research Facilities recommended building a new engine research laboratory. One of the criteria for the site was a location that was not vulnerable to enemy attack and, therefore, not on either coast. There were vulnerability concerns for the other two NACA laboratories. Cleveland, which had been the host of the National Air Races throughout the 1930s, was selected, and

construction began on the new NACA Aircraft Engine Research Laboratory in 1947. The laboratory was renamed the Flight Propulsion Research Laboratory in 1947 and renamed again a year later to Lewis Flight Propulsion Laboratory following the death of George W. Lewis, Director of Aeronautical Research for NACA.<sup>6</sup>

Jet noise reduction became an active area of research at NACA in the 1950s as turbojet engines for commercial aircraft were becoming a reality. The concern over noise generated by high-powered engines on high-performance aircraft resulted in the creation of a NACA Special Subcommittee on Aircraft Noise on March 4, 1952.<sup>7,8</sup> At the time, it was recognized that there was no easy or inexpensive solution for aircraft noise and that source reductions would come at the expense of performance.<sup>9</sup>

Early jet noise work at NACA was conducted with outdoor engine (see Fig. 1) and scale model test stands (see Fig. 2) at Lewis Flight Propulsion Laboratory and a scale model stand at Langley Aeronautical Laboratory. A few studies were conducted with airframes as test beds toward the end of NACA when research was almost entirely focused on noise reduction. The engine test stand was in a field that was unobstructed rearward and to the sides for ½ mile and had thrust measurement capabilities.<sup>10</sup> Acoustic measurements were made at the engine centerline which varied between 6 and 8 ft above ground. The challenges of outdoor testing with scale-model nozzles were recognized early on,<sup>11</sup> and issues with wind gusts were overcome by making measurements on both sides of the jet and evaluating noise reduction concepts on a sound power basis. For both scale-model facilities, acoustic measurements were made at the jet centerline (8 ft for the Langley facility<sup>12</sup> and 10 ft for the Lewis facility<sup>11</sup>). The Altitude Wind Tunnel<sup>5</sup> and the 8 ft x 6 ft Transonic and Supersonic Wind Tunnel<sup>13</sup> at Lewis were used for aerodynamic performance evaluation of noise reduction concepts. None of the measurement environments allowed for scale-model testing in an anechoic environment as is done in modern facilities. Due to the era, research was entirely focused on

turbojet engines and associated jet conditions with exhaust speeds that were both subsonic and supersonic. Some studies included afterburning. While researchers recognized the need to quantify noise impact on the community, the metrics used today (effective perceived noise levels) were not developed until after the conclusion of NACA.

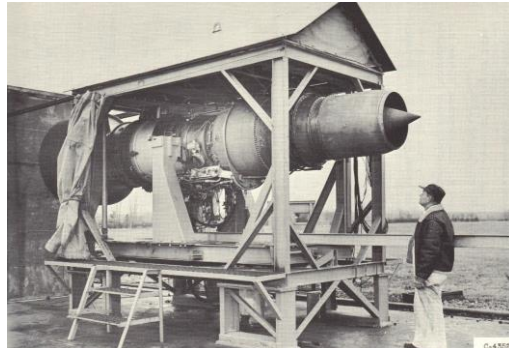

FIG. 2. The NACA outdoor engine test stand at Lewis Flight Propulsion Laboratory.



FIG. 1. The NACA scale-model rig at Lewis Flight Propulsion Laboratory.

Near the beginning of the jet-noise work at NACA, researchers were interested in quantifying the impact of common parameters such as diameter, velocity, density, and turbulence on acoustic radiation and looked at directivity characteristics.<sup>12,14,15</sup> To change jet density and speed of sound, helium was used, something used today in some small-scale facilities. Overall sound pressure (based on pressure rather than pressure squared) was shown to vary with jet diameter, the 3.0 to 3.7 power of the jet velocity, and turbulence levels. The peak radiation angle was impacted by jet temperature. The frequency of the peak amplitude increased with increasing velocity, a fact that supports the Strouhal scaling used for single stream jets today. It should be noted that the velocity scaling power

was slightly lower than that predicted by Lighthill<sup>16</sup> in that same year likely due to the fact that the measurements were made at 90° to the jet axis. Near-field investigations showed high-frequency acoustic radiation peaked close to the nozzle while low-frequency radiation peaked several jet diameters downstream and the presence of a ground plane could result in increased radiation.<sup>17</sup> With the expectation that low-frequency noise components were associated with large eddies and higher frequency noise was associated with smaller eddies, detailed near-field acoustic measurements and hot-wire flow measurements were undertaken, and it was found that the acoustic wavelength increased at a faster rate than the scale of the turbulence with downstream distance from the nozzle.<sup>15</sup> Concerns over structural loading led to some of the first detailed mappings of the near-field acoustic pressures produced by a high-pressure ratio (2.2 without afterburning and 2.59 with afterburning) engine.<sup>18</sup> Research interests were not limited to mixing noise (as turbojet exhausts were not limited to the subsonic regime) and foundational work in sound generation from the interaction of shear waves with shock waves was well underway.<sup>19</sup>

The interest in comparing scale-model and engine measurements was evident in the research of this era, which was understandable as any noise reduction concepts would ultimately have to be evaluated on an engine. The multiple scale-model jet-noise rigs and the engine stand at NACA provided a unique opportunity for direct comparisons, and fundamental scaling laws had been confirmed in early testing. Initial comparisons showed general noise trends for both types of jets were similar but sound pressure levels were roughly 5 dB higher for the engine.<sup>12</sup> Later detailed experiments showed that sound generation from scale-model and engine data followed the scaling laws of Lighthill ( $\rho_0 AV^8/a_0^5$ ), where  $\rho_0$  is the ambient density,  $A$  is the jet exit area,  $V$  is the jet velocity, and  $a_0$  is the ambient speed of sound. Near the peak jet noise angle, the engine produced slightly higher ( $\leq 2$  dB) levels than those produced by the scale model.<sup>20,21</sup>

Focus quickly turned from fundamental research to noise reduction investigations. Researchers were influenced by Lighthill's theory and by the "toothed" nozzle studies of Westley and Lilley<sup>22</sup> and Greatrex<sup>23</sup> and searched for approaches to enhance jet mixing as a means to reduce jet velocity and, therefore, jet noise. Noise reduction effectiveness was often evaluated on the basis of sound power since a perceived noise metric for aircraft had not yet been developed and sound power (as opposed to sound pressure level) reduced uncertainty associated with the outdoor measurements as noted above. The original "toothed" nozzles tested by NACA<sup>24</sup> were intended to represent scaled-up versions of the "best" concepts from Westley and Lilley. These nozzles, looking something like a rough version of the modern-day chevron (see Fig. 3), reduced radiation in the peak jet-noise direction while increasing radiation in the forward arc and at angles near the broadside of the jet. Thrust measurements led to the conclusion that similar sound power reductions as those from the toothed nozzles could be realized by throttling the turbojet engine with a standard nozzle.<sup>25</sup> The toothed nozzle experiments were followed by concepts for corrugated/Greatrex nozzles, a segmented nozzle, and a number of slotted nozzles (see Fig. 4) looking something like a rough version of distributed exhaust nozzles tested in more modern times.<sup>26</sup> Only slight noise reduction was achieved with the corrugated nozzle. Some of the slotted nozzles achieved significant noise reduction in the peak jet-noise direction often with decreases in low frequency radiation and increases in high frequency radiation. All configurations resulted in thrust loss. Lobed mixers and tube nozzles in addition to segmented nozzles followed in tests which looked at acoustic radiation and aerodynamic performance (see Fig. 5).<sup>27</sup> In this study, an attempt was made to quantify the annoyance of a flyover for each noise-reduction concept by integrating the area under the curve of loudness (in sones) versus time. Of all nozzles tested, the lobed mixers produced noise reductions over the largest number of observation angles, although one of the tube nozzles produced a slightly lower annoyance level. The aerodynamic losses of the tubed nozzles were greater than those for the



lobed mixers, which were considered the best nozzle choice for balancing noise reduction and aerodynamic performance.

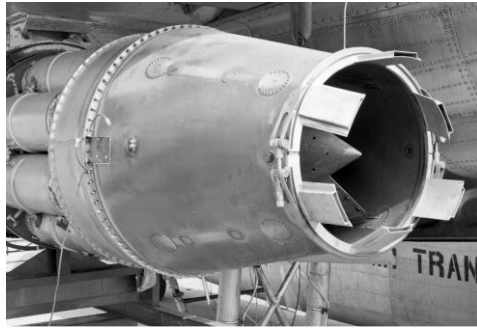

FIG. 3. The original toothed nozzle tested at NACA. Reprinted with permission from E. E. Cllaghan, W. Howes, and W. North, NACA-RM-E54B01, National Advisory Committee for Aeronautics, Washington, DC (1954) (Ref. 24).

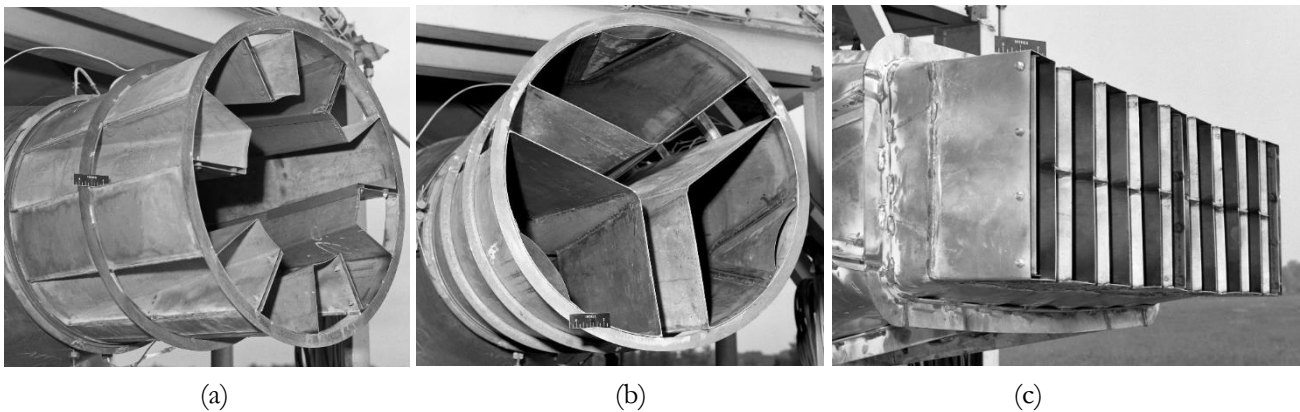
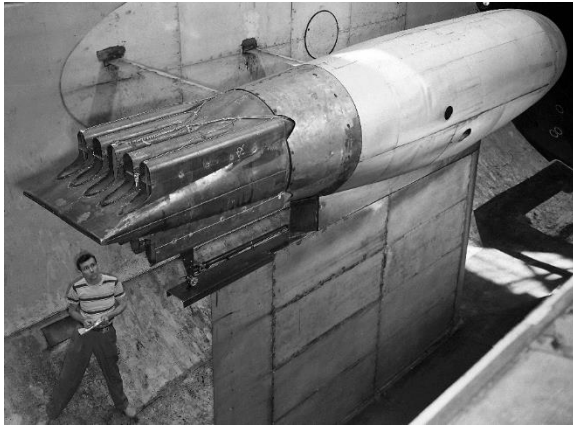
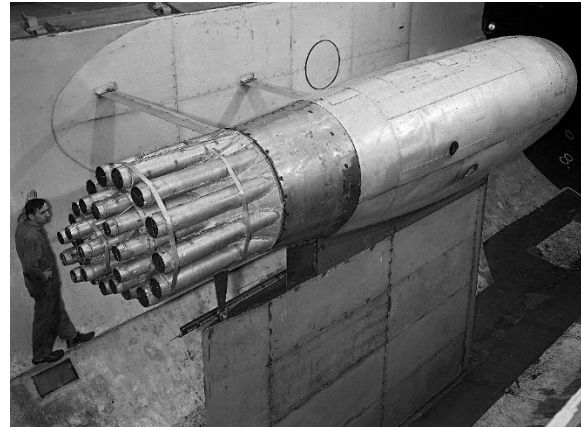

FIG. 4. The (a) corrugated/Greatrex, (b) three-segmented, and (c) rectangular-slotted nozzles tested at NACA. Reprinted with permission from W. D. Coles and E. E. Callaghan, NACA-TN-3974, National Advisory Committee for Aeronautics, Washington, DC (1957) (Ref. 10).

The beginning of NACA's (and later NASA's) interest in ejectors as jet noise reduction devices could not be missed, although initial measurements showed little or no acoustic benefit and ejector resonances could be problematic.<sup>28</sup> In these early experiments, the ejector was believed to have the potential to reduce noise through the reduction of shear at the nozzle exit (as shown in fundamental experiments with single-stream laboratory jets<sup>29</sup>) without reducing core velocity, and ejectors were



(a)



(b)

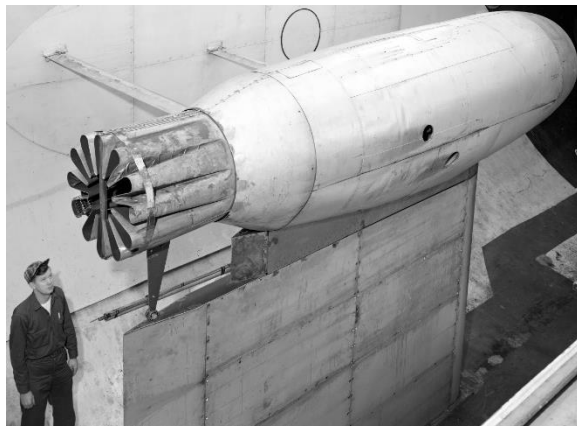

(c)

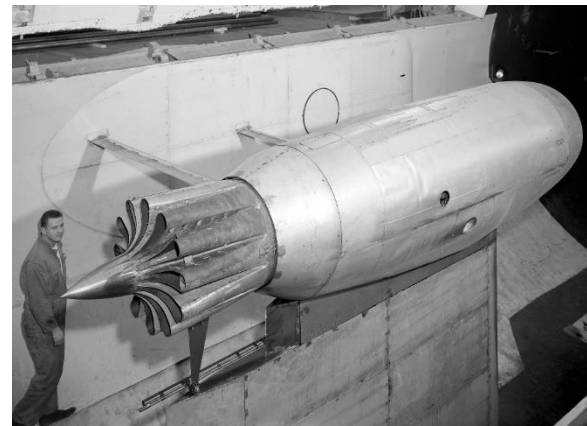

(d)

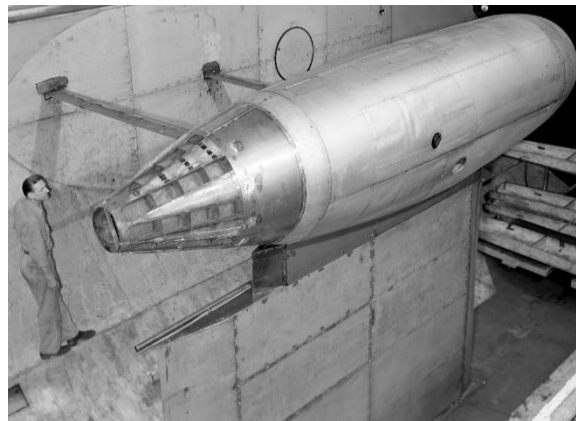

(e)

FIG. 5. The (a) 10-tube, (b) 31-tube, (c) 12-lobe, (d) 12-lobe plus centerbody, and (e) segmented-lobe nozzles tested at NACA. Reprinted with permission from C. C. Ciepluch, W. J. North, W. D. Coles, and R. J. Antl, NACA-TN-4261, National Advisory Committee for Aeronautics, Washington, DC (1958) (Ref. 27).

already being used on engines for cooling. Mixer-ejector combinations (see Fig. 6) emerged as a

solution to the poorly performing ejector with the idea that fully mixing the induced flow and primary jet within the length of the ejector would result in lower velocities (relative to the primary jet velocity) and, therefore, reduced noise. Two different lobed mixers were combined with ejectors of different lengths and diameters, which resulted in reductions of the peak sound pressure levels (relative to that of the baseline round nozzle) of 3 and 7 dB for the 12 and 8 lobed mixers, respectively, and 9 dB and 12 dB when those same mixers were combined with ejectors.<sup>30</sup> The noise reductions were over the entire frequency range. Ejector length and diameter impacted noise reduction. Noise generation within the ejector was suspected of reducing the expected noise benefits of the mixer-ejector concepts. An ejector combined with a mixing nozzle looking something like the toothed nozzle (see Fig. 7) resulted in an annoyance (based on the loudness metric mentioned above) that was close to that of the best tube nozzle and slightly lower than that for lobed mixers, and the concept had low propulsive thrust losses.<sup>27</sup> Researchers acknowledged it would weigh more than a simple round nozzle. Measurements at representative cruise conditions showed the drag for



FIG. 6. A mixer-ejector concept tested at NACA. Reprinted with permission from W. D. Coles, J. A. Mihalow, and E. E. August, NACA-TN-4317, National Advisory Committee for Aeronautics, Washington, DC (1958) (Ref. 30).

the lobed mixer-ejector was nearly 3 times that of the lobed mixer alone, leading to the suggestion of a retractable ejector that could be stowed after takeoff.<sup>31</sup>

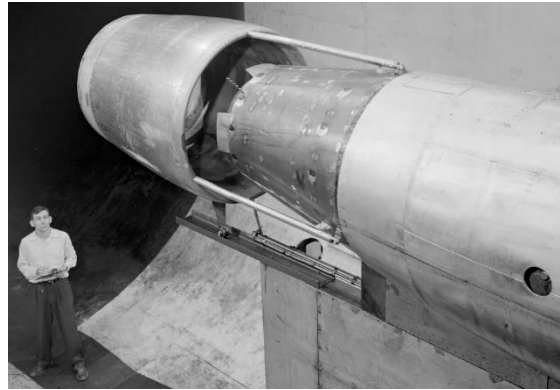

FIG. 7. A mixing nozzle with ejector tested at NACA. Reprinted with permission from C. C. Ciepluch, W. J. North, W. D. Coles, and R. J. Antl, NACA-TN-4261, National Advisory Committee on Aeronautics, Washington, DC (1958) (Ref. 27).

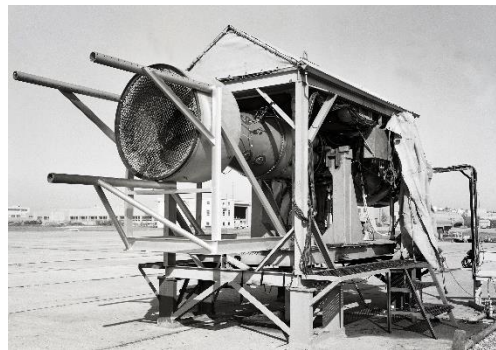

FIG. 8. A screened noise reduction concept investigated at NACA. Reprinted with permission from W. D. Coles and W. J. North, NACA-TN-4033, National Advisory Committee for Aeronautics, Washington, DC (1957) (Ref. 32).

In addition to investigating in-flight applications, NACA considered noise reduction concepts for ground applications. The use of a screen in the jet exhaust normal to the jet axis and water injection (see Figs. 8 and 9) were found to reduce noise, although not easy to implement and could only be used for ground operations. The screen concepts reduced noise in the peak jet-noise direction but required a muffler to control noise increases in the forward arc.<sup>17,32,34</sup> The water

injection concept used up to 800 gal/min for noise reduction.<sup>33</sup> The screens were envisioned as noise reduction concepts for ground run-ups or carrier deck catapult launches. The water injection concepts would have been unrealistic for catapult launches.



FIG. 9. A water-injection noise reduction concept investigated at NACA. Reprinted with permission from M. C. Kurbjun, NACA-RM-L57L05, National Advisory Committee for Aeronautics, Washington, DC (1958) (Ref. 33).

Toward the conclusion of the 1950s, there was consensus that an augmented space program was necessary, and there was competition from several agencies for that program. NACA had been devoting more of its resources to missile research during this decade, and the view of NACA as a peaceful, research-oriented agency fed into the final decision to establish a civilian aeronautical and space research agency which would absorb NACA. The National Aeronautics and Space Act was signed by President Eisenhower on July 29, 1958. NASA began on October 1, 1958 and all assets and personnel from NACA were transferred into the new agency.

### III. NASA EARLY YEARS – THE ERA OF TURBOJETS

The space race was not the only concern in the early years of the space agency. Commercial aviation using turbojets was emerging with the first jet airliner, the British de Havilland Comet, going into service in 1952. The Boeing 707 followed on October 26, 1958, and the Douglas DC-8 on September 18, 1959. All three of these aircraft were powered by four turbojet engines. On

October 4, 1958, The Port of New York Authority announced a decision to allow regular operations of the de Havilland Comet and the Boeing 707 at the New York International Airport with noise abatement procedures designed to protect the communities near the airport.<sup>35</sup> By 1959, The Port of New York Authority funded the development of a perceived noise metric as a result of community outcry over jet noise, and the basis for the effective perceived noise level (EPNL) metric used today began to emerge.<sup>36,37</sup> The first Federal Aviation Administration (FAA) noise regulation would not follow until the end of the next decade.

In the first few years of the space agency, NASA was driven by the understanding that the turbojet powered commercial aircraft industry was emerging and these aircraft would likely be taking off near densely populated communities where noise was going to be an issue. As such, jet noise work was concentrated on noise reduction technologies. One of the first jet-noise reports to emerge from NASA looked at slotted nozzles (see Fig. 10) as a result of proposals to use the exhaust from these nozzles to enhance lift of short takeoff and landing (STOL) and vertical takeoff and landing (VTOL) aircraft.<sup>38</sup> Enhanced lift concepts would be revisited in the NASA programs of the 1970s. This early study showed that, relative to the round nozzle, sound pressure levels were decreased in the plane containing the nozzle major axis and increased in the plane containing the nozzle minor axis. Slotted nozzle<sup>39</sup> and mixer-ejector<sup>40</sup> work continued under NASA. With the mixer ejector work (see Fig. 11), NASA was now including flight tests in jet noise studies and applying the newly developed perceived noise metrics. The lobed mixer produced up to 6 PNdB reduction with a 5 – 7.5% range penalty relative to the standard exhaust nozzle, and adding an ejector provided little or no noise benefit. In addition to the noise reduction work, fundamental similarity studies for far-field noise were also pursued.<sup>41</sup>



(a)



(b)

FIG. 10. A slotted nozzle concept investigated at NASA in the (a) horizontal and (b) vertical clocking positions for noise measurements in the planes containing the major and minor nozzle axes, respectively. Reprinted with permission from W. D. Coles, NASA-TN-D-60, National Aeronautics and Space Administration, Washington, DC (1959) (Ref. 38).



(a)



(b)

FIG. 11. Photographs of a mixer concept investigated at NASA showing (a) the combined mixer-ejector and (b) the ejector alone. Reprinted with permission from W. D. Coles, J. A. Mihalow, and W. H. Swann, NASA-TN-D-874, National Aeronautics and Space Administration, Washington, DC (1967) (Ref. 40).

#### IV. NASA PROGRAMS

As NASA programs began to take shape, research was divided into a fundamental (base) program and focused programs. In the fundamental programs, researchers developed and tested

initial ideas. The fundamental work transitioned to a focused program once it reached an appropriate maturity level. Research for subsonic and supersonic aircraft was covered under different programs. Research targets for noise were based on reductions relative to current aircraft and anticipated future regulations. The base or fundamental program ended in the mid 1990s, and all work was conducted under focused programs. In 2006, NASA reorganized aeronautics to emphasize fundamental research and the Fundamental Aeronautics Program (FAP) began. The FAP focused on prediction methods and validation experiments and less on specific aircraft applications. Jet-noise research was conducted under the Subsonic Fixed Wing (SFW) or Supersonics (SUP) projects within FAP. The names of the program (now the Advanced Air Vehicles Program) and projects have changed over time, but the research continues to be organized into projects for subsonic fixed wing and supersonic aircraft. The continuous increase in bypass ratio (BPR) and reduced exhaust velocities for commercial subsonic aircraft with time has led to the majority of NASA jet noise work today being focused on supersonic applications.

#### **A. Subsonic programs and projects**

On October 29, 1965 the Jet Aircraft Noise Panel was convened by the Office of Science and Technology, Executive Office of the President, as a result of increased public concern over aircraft noise due to the introduction of heavier jet airliners and increased air transportation volume. The FAA and NASA were represented on the Panel. The panel report, released in March 1966,<sup>42</sup> identified turbine engine noise as the main noise source at takeoff and concluded that suppression of jet noise was technically feasible but costly. The panel recommended that operational procedures be considered for aircraft noise reduction, the FAA should seek authority from Congress to formulate noise regulations, the FAA and/or NASA should establish an urgent research program for quantitative noise evaluation and standards, and the Federal Government should undertake studies to develop estimates of the cost to diminish noise. Following the release of this report, The Aircraft



Noise Abatement Act of 1968<sup>43</sup> gave the FAA the authority to prescribe rules and regulations for aircraft noise and sonic boom. On December 1, 1969, the FAA added Part 36 to the Federal Aviation Regulations, which established allowable noise levels for jet-powered and large, transport category aircraft (based on EPNdB), and the era of the FAA Stage 2 limits began. NASA initiated studies for the practical control of noise, and the Quiet Engine Program (QEP), largely focused on building and testing a Quiet Engine, began in 1967.

The Quiet Engine began with the Quiet Engine Definition Program aimed at the selection of engine cycles and mechanical features that would produce quiet engines for subsonic commercial jet aircraft.<sup>44</sup> An engine would be considered quiet if the take-off and landing-approach levels were 15 - 20 PNdB below those of the JT3D and JT8D turbofan engines. The transition to turbofan engines for US manufacturers began in 1960 with the DC-8, and NASA had begun investigating noise characteristics of heated coannular jets as a result of the introduction of turbofan engines prior to the initiation of QEP.<sup>45</sup> Jet-noise reduction under the QEP focused on the selection of the appropriate engine cycle.<sup>46</sup> Initial studies by NASA showed promise for bypass ratios around 5.0. More detailed industry studies followed, and the selected Quiet Engine designs were in the bypass ratio range of 5.4 – 5.5,<sup>47,48</sup> a considerable increase from the JT3D with a bypass ratio of 1.41. The industry studies identified a large uncertainty for noise associated with suppressed fans,<sup>49</sup> so fan noise research became the focus in the follow-on investigations. The design and manufacture of a quiet engine began in 1969, ground testing of several fans followed in 1972, and final reports were submitted in 1975. One interesting research focus involved climbout procedures, which showed some potential for reduced perceived noise levels with reduced power levels during a second segment climb.<sup>50,51</sup>

The Advanced Transport Technology Program (ATTP) was initiated around 1970. The intent of the program was quite different from the QEP with the goal of defining and developing advanced

technologies for the next generation of conventional aircraft with a cruise Mach number near 1.0.<sup>52</sup> The program was divided into three elements: airframe and engine studies, technology development, and exploratory flight vehicles. For the system studies, the airframe component was led by Langley Research Center and the engine component was led by Lewis Research Center. The supercritical airfoil figured prominently in the NASA Langley work. From a jet-noise point of view, the program was very similar to QEP as it relied on cycle for reduced jet noise. In-house studies looked at the high end of the Mach number range and found that low bypass ratio engines (around 2) were optimum for cruise Mach numbers around 1.15 but would not meet current noise regulations due to jet noise levels (Stage 2 at the time) without throttling at takeoff.<sup>53</sup> Initial industry studies focused on cruise Mach numbers in the lower range of interest for ATTP (up to 0.98) initially with noise goals up to 15 EPNdB below FAA regulations.<sup>54,55</sup> The engine concepts selected fell in the 4.1 – 6.5 bypass ratio range and met the jet noise requirements. Follow-on studies with stricter noise goals (20 EPNdB below FAA regulations), slightly lower cruise Mach numbers (0.9), and more unconventional concepts resulted in a variable geometry engine with bypass ratios between 5.6 and 6.5<sup>56,57</sup> and a geared fan with a bypass ratio up to 10.<sup>57</sup> An interesting aspect of the system studies was the use of SAE AIP 876 (the precursor to the current SAE ARP 876F) for forward flight effects<sup>54</sup> likely due to the limited data available for forward flight corrections. However, comparisons between engine measurements and the SAE model showed engine levels were higher than those predicted.<sup>58</sup>

On March 7, 1971, a joint study by the Department of Transportation (DOT) and NASA was released.<sup>59</sup> The study, initiated at the recommendation of the Senate Committee on Aeronautics and Space Sciences, considered the role of government supported aeronautics research and identified airport noise and congestion as areas that could impact air transportation growth. A new short-haul air transportation system separate (to the extent possible) from the long-haul system was identified

as having the potential to alleviate airport congestion.<sup>60</sup> This system would benefit from aircraft with STOL capabilities due to the potentially short runways. As a result of this study, STOL research began at NASA with the first research aircraft, developed in a joint program between NASA and the Canadian Government, delivered to NASA in 1972.<sup>61</sup> A second research aircraft, the Quiet Short-Haul Research Aircraft (QSRA), completed its first flight in 1978.<sup>62</sup> The Quiet Clean Short-Haul Experimental Engine (QCSEE) program began in 1974 and focused on the design and fabrication of quiet engines that could be used to augment lift in STOL aircraft and would result in low sideline noise levels.<sup>63</sup> Two QCSEE engines were delivered to NASA Lewis in 1978 and tested in 1979. These engines had bypass ratios of 10.2 and 11.8.<sup>64</sup> Full-scale engine studies were relatively popular in the STOL programs, and these investigations were conducted in the Vertical Lift Fan (VLF) Facility and the Engine Noise Test Facility. The VLF used microphones attached to 60 ft boom cranes for sideline acoustics, and the Engine Noise Test Facility used a combination of microphones suspended from a cable hanging between 120 and 60 ft towers and microphones suspended from a 60 ft boom crane (see Fig. 12).<sup>65</sup> These facilities suffered from ground reflections, which made use of the data challenging for model validation.<sup>66</sup>

The QCSEE program was important for jet noise as it resulted in significant jet-flap interaction studies and wing shielding research. Under-the-wing (UTW) and over-the-wing (OTW) concepts

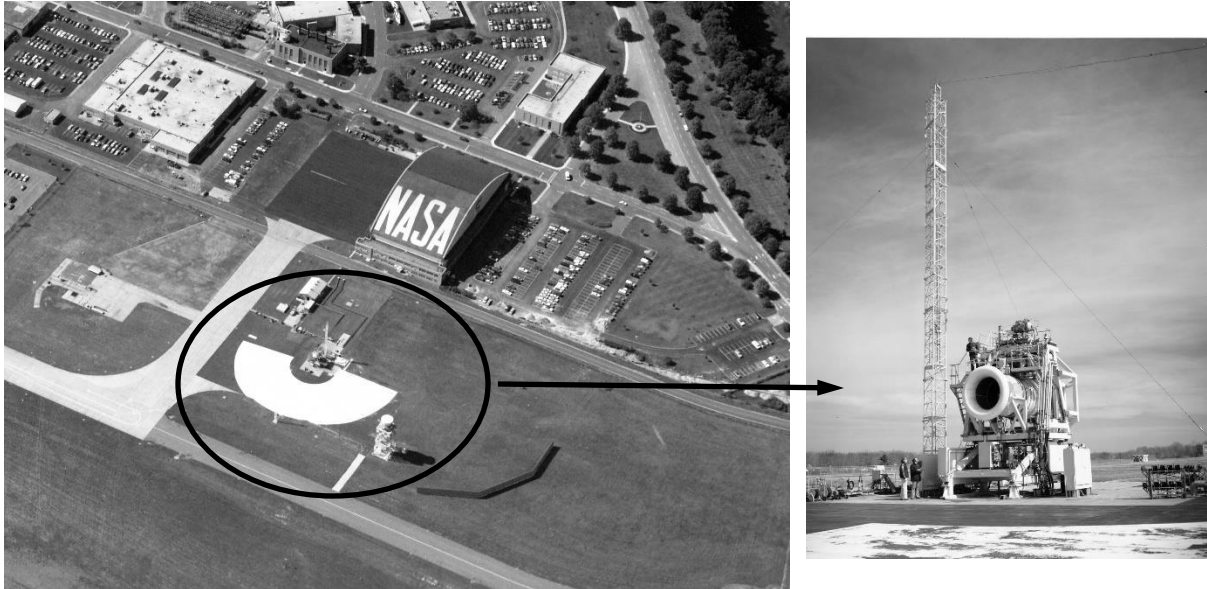

FIG. 12. The Engine Noise Test Facility used in the QCSEE program at NASA Lewis.

were investigated (see Fig. 13).<sup>67</sup> The high bypass ratio of the engines resulted in lower exhaust speeds (relative to the low bypass ratio commercial engines at the time), and mixing nozzles played an important part of the research as these nozzles provided additional reductions in jet velocity and blown flap noise was found to be correlated with flow impingement velocity.<sup>68,69</sup> However, mixing nozzles change the radial velocity profile, moving the peak velocity outward radially from the jet centerline so jet-impingement noise can become problematic (relative to that for the conical nozzle) when the flap angle is reduced from that used for landing to that used for takeoff.<sup>68</sup> A number of blown-flap noise prediction schemes emerged from this work and included empirical correlations and estimates of noise components.<sup>66,70-74</sup> The shielding work focused on the OTW concepts and showed the acoustic benefits of this type of installation.<sup>75</sup> Earlier experiments indicated noise reductions were predominantly at high frequencies and highlighted the potential for noise increases with uncovered slots.<sup>76</sup> The effect of the nozzle size, type, and exhaust plane relative to the wing leading edge were also investigated.<sup>77</sup>

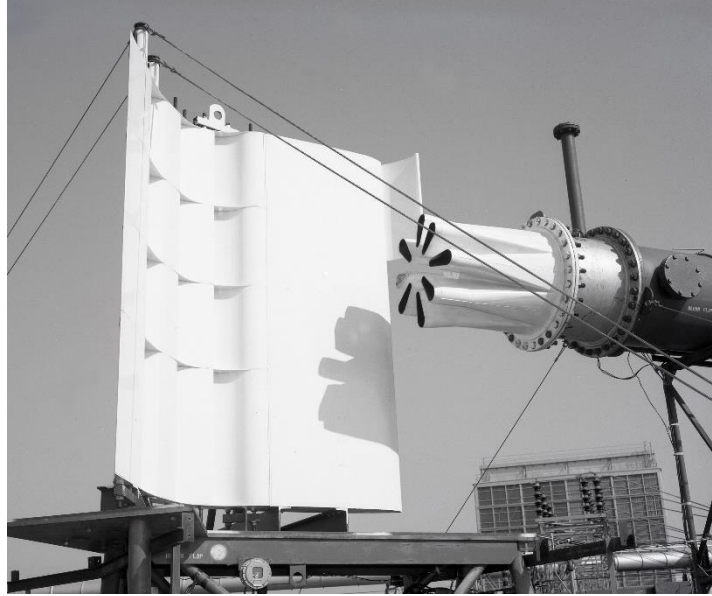

FIG. 13. An under-the-wing model system used in the ACSEE program. Reprinted with permission from J. H. Goodykoontz, J. M. Wagner, and N. B. Sargent, NASA-TM-2776, National Aeronautics and Space Administration, Washington, DC (1973), (Ref. 67).

Flight effects research gained significant attention in the 1970s as it was important to accurately predict noise levels of emerging aircraft and understand the impact of forward flight on noise reduction concepts. Data were acquired for aircraft in flight,<sup>40,78,79</sup> engines installed in NASA's 40 ft x 80 ft Tunnel at Ames,<sup>80,81</sup> and scale models<sup>82,83</sup> (see Fig. 14)<sup>84</sup> using a free jet. Each of these approaches had limitations, with the flight tests suffering from contamination by sources other than jet noise, the 40 ft x 80 ft tunnel requiring reverberation corrections and being limited on microphone distance, and the scale-model data being impacted by shear-layer refraction that led to the need for the development of shear layer corrections.<sup>85</sup> One novel experiment worth noting was a jet mounted on a moving automobile (see Fig. 15).<sup>86</sup> It was recognized in early work that relative velocity was an important scaling parameter,<sup>40,82</sup> and prediction methods, now part of NASA's Aircraft Noise Prediction Program (ANOPP), would soon follow<sup>87</sup>. The SAE ARP 876 was updated to include flight corrections in 1981 and, while the standard was separate from the prediction work

at NASA, NASA Langley verified the SAE model.<sup>88</sup> The controversy over the correct jet noise models and flight corrections continues today.

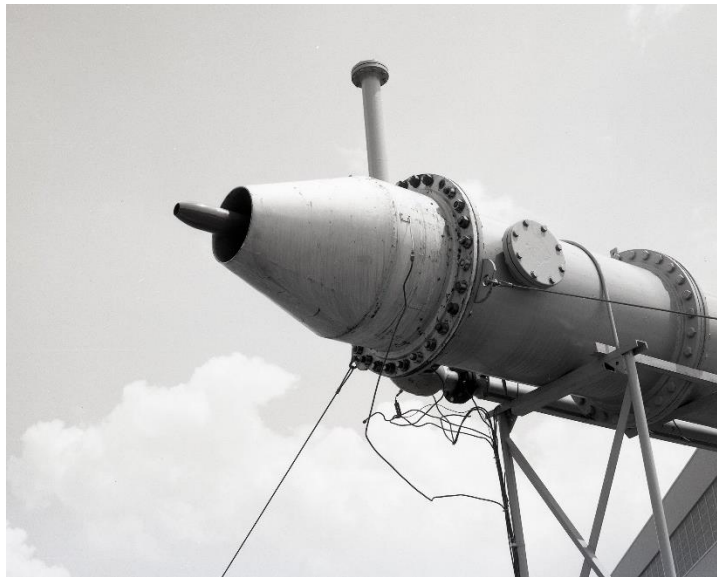

FIG. 14. The scale-model nozzle system used for forward-flight experiments. Reprinted with permission from U. Bon Glahn and J. Goodykoontz, NASA-TM-X-71438, National Aeronautics and Space Administration, Washington, DC (1973) (Ref. 84).



FIG. 15. A setup used to investigate the effects of forward flight on jet noise radiation. Reprinted with permission from T. D. Norum, NASA-TP-1326, National Aeronautics and Space Administration, Washington, DC (1978) (Ref. 86).

The oil embargo of 1973 and the resulting energy crisis significantly impacted the aviation industry due to rising fuel costs. In 1975, two senators on the Committee on Aeronautical and Space Sciences sent a letter to the NASA administrator requesting a plan to develop new technologies aimed at reducing the impact of the energy crisis.<sup>89</sup> The program would result in technology transfer to industry and would focus on a new generation of fuel-efficient aircraft that would enter service in the 1980s. NASA established an Aircraft Fuel Conservation Technology Task Force within a month and an advisory board followed. The Committee and board developed the overall goal of a technology readiness level (TRL) by 1985 for a 50% reduction in fuel consumption for new civil aircraft without compromising the environment and safety. The resulting Aircraft Energy Efficiency (ACEE) program began in 1976. Six projects comprised the ACEE program, three of which were propulsion related and managed by NASA Lewis. These projects were the Engine Component Improvement project for short-term improvements to existing engines, the Energy Efficient Engine (E<sup>3</sup>) for developing a new efficient engine, and the Advanced Turboprop Project (ATP). Jet noise work was included in E<sup>3</sup>. The ACEE program ended in 1987.

Internal mixers were explored in E<sup>3</sup> to increase thrust and decrease jet noise. Scale-model tests documented the contribution of high-frequency internally generated noise to the total far-field acoustic radiation. Flow measurements were used to evaluate the degree of mixing. Full-scale engine tests of the mixer and exhaust system followed and focused on mixing effectiveness.<sup>90</sup> The mixer work from the E<sup>3</sup> program would serve as a starting point for NASA's Advanced Subsonic Technology (AST) program that was conducted in the 1990s. Fundamental work during this period included the development of scaling rules for noise radiated from subsonic jets.<sup>91</sup>

In 1991, the acoustic research emphasis switched from high-efficiency propulsion systems of interest in the 1980s (i.e., the advanced turboprop) to noise reduction for turbofans, and the AST program was officially started in 1994. Research at NASA returned to the development of ultra-

high-bypass ratio (UHBR) turbofans to significantly reduce engine noise. Industry worked with NASA to define baseline noise levels for “1992 Technology” reference vehicles.<sup>92</sup> Results from the study were used to set near-term and long-term noise reduction goals. For jet noise, the goal was to provide technologies for source noise reductions of 3 EPNdB by 1996 and 8 EPNdB by 2000 (note the goals were not cumulative). The program was originally planned with a focus on fan noise reduction with no jet noise research. NASA returned to the engine cycle that was successful during the QSCEE program. Pratt & Whitney (P & W) had already tested the Advanced Ducted Propulsor (ADP) 17-in model fan in their United Technologies Research Center (UTRC) wind tunnel, and the NASA 9 ft x15 ft Low-Speed Wind Tunnel and 8 ft x 6 ft Supersonic Wind Tunnel were used for noise and performance assessments. General Electric (GE) was developing their GE90 engine based on E<sup>3</sup> technologies with bypass ratios of 8-9. A study had shown jet noise levels were lower than fan and core components.<sup>93</sup> However, it was quickly realized that engines with bypass ratios around 5 still existed, and higher bypass-ratio engines could not be justified for lower thrust turbofans with internal mixers and long ducts. To address the jet noise concerns, NASA increased funding, and the FAA augmented those funds to include jet noise reduction research for moderate bypass ratios. Experimental research in the AST program made extensive use of the Aero-Acoustic Propulsion Laboratory (AAPL).<sup>94</sup> The AAPL (see Fig. 16) is a 66 ft radius geodesic dome treated with acoustic wedges, built in 1991 to contain noise from the Power Lift Facility, and houses the Nozzle Acoustic Test Rig (NATR). The NATR has a 53 in. diameter simulated forward flight stream reaching speeds up to Mach 0.35 and encompassing the multi-stream, heated High Flow Jet Exit Rig (HFJER) built for the HSR (High Speed Research) program.



Initial jet-noise research in the AST program focused on bypass ratios of 1.5 to 6. It was believed that long duct internal mixers with acoustic treatment used to control internally generated high-frequency noise were the best option for noise reduction aside from reducing jet velocity. GE retested mixers used during the E<sup>3</sup> program to develop a database for computational fluid dynamics (CFD) and improved design methods.<sup>95</sup> Allison designed mixers for smaller turbofan engine

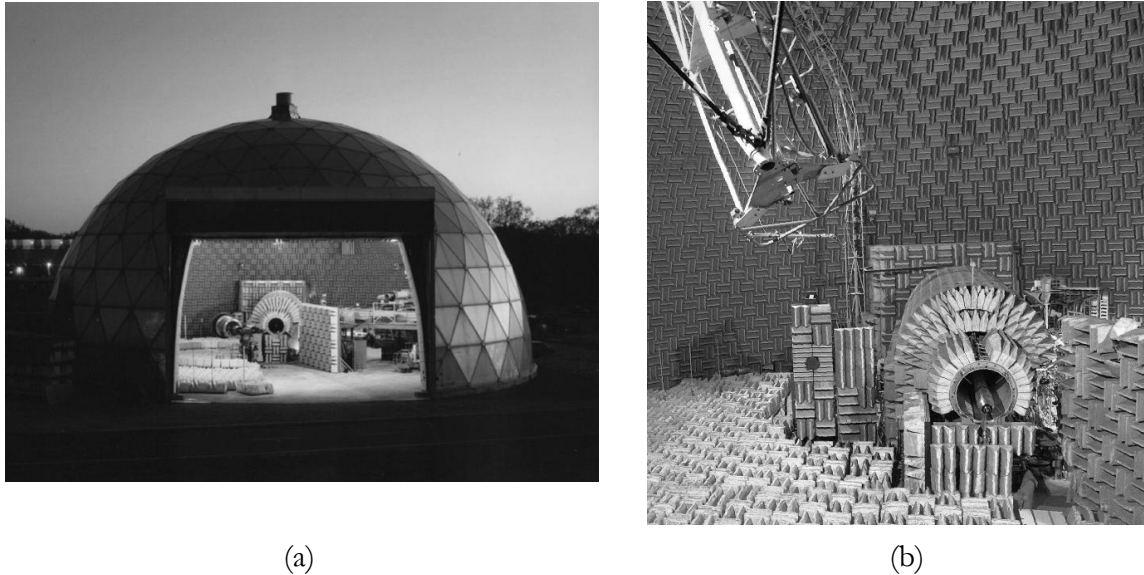

FIG. 16. Photographs of (a) the Aero-Acoustic Propulsion Laboratory (AAPL) and (b) the Nozzle Acoustic Test Rig (NATR) within the AAPL at the NASA Glenn Research Center.

applications to investigate the impact of lobe number and penetration. Model scale tests conducted in AAPL between 1995 and 1997 projected a jet noise reduction of 1 to 3 EPNdB depending on the net thrust of the engine.<sup>96</sup> Using mixers on higher bypass ratio engines was a challenge due to size and weight, so NASA initiated a research program for separate flow exhaust nozzles with a focus on chevrons and tabs. The test program involved P & W<sup>97</sup> and GE/Allison<sup>98</sup>. Model tests for chevron nozzles on both the core and fan duct showed up to 3.4 EPNdB reduction relative to a baseline nozzle for a BPR of 5 nozzle system. The noise reduction benefits diminished to 1.5 EPNdB when the BPR was increased to 8.<sup>98</sup> Noise reductions in the range of 2.5 to 3 EPNdB were achieved with a thrust loss of less than 0.25%.<sup>99</sup> This was a breakthrough as previous noise reduction concepts were

associated with significant thrust loss. Honeywell conducted static tests on their TFE731-60 engine (with a bypass ratio of roughly 5) in 1999, followed by flight tests in 2001 on a Falcon 20 test aircraft to investigate chevron nozzles and a variable area nozzle. Flight test results confirmed the chevron nozzles provided roughly 3 EPNdB jet noise reduction as projected from model scale and static engine tests.<sup>100</sup> Chevrons were tested in 2001 on a Learjet 25 to verify jet noise reduction.<sup>101</sup> Several companies pursued their own version of chevrons and GE introduced the first production implementation on a CF34 in 2003, and several other aircraft have introduced chevron nozzles including the Boeing 787 and the 747-8. A review of the chevron nozzle development provides more details.<sup>102</sup> One chevron concept tested during the AST program is shown in Fig. 17.

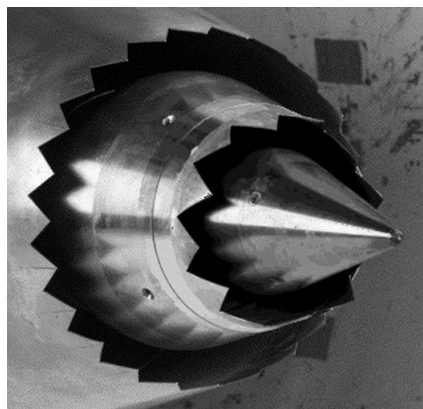

FIG. 17. One of the chevron nozzles tested during the AST program.

The Quiet Aircraft Technology (QAT) program began in 2001 with studies to assess the system-level impact of the noise reduction technologies developed in the AST program. Changing cycle parameters, such as reducing the fan pressure ratio and jet exhaust velocity, provided significant noise reduction, and noise-reduction technologies that could be applied to a fixed engine cycle provided less benefit. Incorporating cycle changes meant increasing engine diameters, which could adversely impact fuel burn due to higher drag, weight, and aircraft installation challenges. Higher bypass ratio engines would eventually make their way into service, so NASA focused the noise reduction research on the most important sources for UHBR engines. The QAT program had goals

of 10 and 20 EPNdB reductions for 10- and 20-year objectives, respectively, relative to a 1997 baseline.<sup>103</sup> The QAT program ended in 2005. The experimental work conducted at NASA made use of the HFJER and the Small Hot Jet Aeroacoustic Rig (SHJAR) in the AAPL facility at NASA Glenn (renamed from NASA Lewis in 1999) as well as the Low Speed Aeroacoustic Wind Tunnel (LSAWT)<sup>104</sup> at NASA Langley. The SHJAR (see Fig. 18) was added to AAPL in 2001 and is a small, single stream, heated jet rig with no simulated forward flight. The LSAWT (see Fig. 19) is an in-draft wind tunnel with a 36 ft x 17 ft x 17 ft (wedge tip to wedge tip) test section and simulated forward flight stream exhausting from a 56 in square nozzle and reaching speeds up to Mach 0.32. Until recently, the LSAWT housed the Jet Engine Simulator (JES), a dual stream jet rig equipped with propane-fired, sudden-expansion burners on both streams and an electric pre-heater.



FIG. 18. The SHJAR in the AAPL facility at NASA Glenn Research Center.

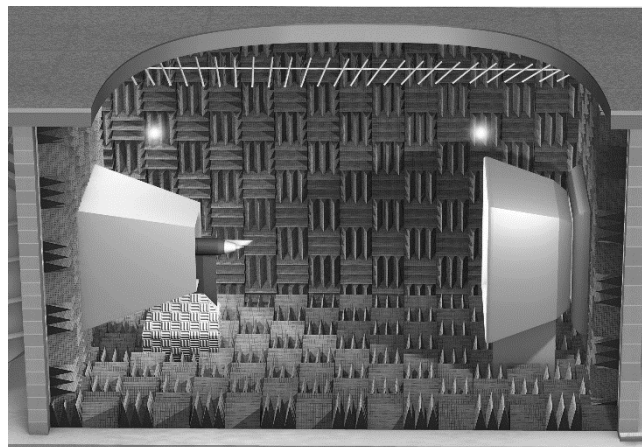

FIG. 19. The LSAWT at NASA Langley Research Center.

Jet noise reduction concepts were focused on offset nozzles to change directivity and spectral content,<sup>105</sup> chevrons made from shape memory alloys to optimize the penetration angle between takeoff and cruise,<sup>106</sup> fluidic injection to enhance mixing or control the breakup of streamwise vorticity from mixing devices such as chevrons,<sup>107,108</sup> and distributed exhaust concepts used to alter the jet noise spectral content.<sup>109,110</sup> Strong emphasis was placed on flow measurements to improve understanding of the noise generation process. Detailed flow and acoustic databases were created to compare and improve jet noise prediction tools.<sup>111-113</sup> Installation effects research emerged and began with a jet-pylon acoustic investigation,<sup>114</sup> and detailed flow-field studies followed shortly after<sup>115</sup>. In 2005, the Quiet Technology Demonstrator 2 (QTD2) cooperative flight test (Boeing, GE, Goodrich, and NASA) was conducted to validate several noise reduction technologies (see Fig. 20). The emphasis for jet noise was on “T-fan chevrons” and adding shape memory alloys to create variable penetration chevrons.<sup>116,117</sup>

In 2004 and 2005 there was uncertainty in the direction of aeronautics research at NASA. NASA Headquarters started to direct all work toward demonstration programs aimed at proving the relevance of fundamental research at higher TRL. The AST and QAT programs provided a long



FIG. 20. A photograph showing a chevron nozzle tested on the Quiet Technology Demonstrator 2 (QTD2) (courtesy Boeing Aerospace Company).  
run of sustained research for noise, and support was waning. In 2006, new management for

aeronautics completely changed the focus back to fundamental research with the decree that programs emulate the NACA years.

The SFW project in the FAP was initiated in 2006. Focus was placed on using ultra-high bypass (UHB) engines as in the AST program. Research was organized by the designations of N+1, N+2, and N+3. The N+1 research targeted technologies for conventional “tube and wing” aircraft and maturation to a technology readiness level of 4 – 6 by 2015. The noise goal for N+1 was a 32 EPNdB cumulative noise reduction below FAA Stage 4 goal. The N+2 work targeted larger aircraft replacements using a configuration such as the hybrid wing body and a maturation date of 2020. The goal for N+2 was 42 EPNdB cumulative below FAA Stage 4. The N+3 work focused on meeting NASA’s long-term goal of containing objectionable noise within an average airport boundary by 2025. The noise target of 71 EPNdB cumulative below FAA Stage 4 was selected for this effort as it roughly corresponded with the EPA goal of 55 day night sound level (DNL) noise contours at an average airport boundary.<sup>118</sup> Early in the SFW project, previous research from the QAT program was extended and focused on offset stream technologies for multi-stream jets and included physically offsetting one stream and using vanes in the bypass nozzle.<sup>119</sup> Emphasis was also placed on acquiring a dataset for validating high-fidelity prediction codes.<sup>120</sup> Many experimental investigations combined subsonic and supersonic jet noise efforts, the results of which will be reported in Sec. IV C. Today, the subsonic fixed wing work is performed under the Advanced Air Transport Technology (AATT) project, and the noise targets have changed from those used in the initial stages of the SFW project. Additionally, due to increased engine bypass ratios, jet noise research is no longer conducted under this project, as it is expected that jet noise from commercial subsonic aircraft will fall within FAA limits in the foreseeable future.

As work in the Fundamental Aeronautics Program matured, it was integrated into demonstrator type experiments in the Environmentally Responsible Aviation project of the Integrated Systems Research Program (what is now the Integrated Aviation Systems Program). Under this project, a scale-model hybrid wing with jet engine simulators was tested in NASA Langley's 14 x 22 Tunnel in 2012.<sup>121</sup> The work included significant jet noise shielding research<sup>122</sup> guided by earlier scale-model experiments in Boeing's Low Speed Aeroacoustics Facility (LSAF)<sup>123</sup>. The results showed significant reductions (up to 10 dB) from a combination of chevrons and shielding from the hybrid wing body. The hybrid wing model is shown in Fig. 21.



FIG. 21. The hybrid wing scale model in the 14 x 22 tunnel at NASA Langley Research Center.

## **B. Jet noise prediction codes**

The NASA Aircraft Noise Prediction Program (ANOPP) for predicting aircraft system noise was initiated at NASA Langley in 1973 and addressed a need to independently evaluate benefits from noise reduction research programs by the government. Engine modules using empirical and semiempirical prediction methods were developed by NASA Lewis. The jet, core, fan, and turbine noise models were developed in-house based on data from NASA and industry. Initial reports were designated interim, but the final reports were never written<sup>124-127</sup> which turned out to be appropriate as the modules have been continuously updated and improved using data from newer engines. The original jet noise prediction interim report used an approach where functions for normalized

directivity in 1/3 octave bands at various observation angles were combined with a normalized sound pressure level spectrum at a 90° observation angle. Turbulent mixing noise and shock noise functions for single stream circular jets, coaxial jets, slot nozzles, and plugged nozzles were developed for static and simulated forward flight conditions.<sup>124</sup> Improvements to existing jet noise models<sup>87,128,129</sup> have occurred over time, and the original model (known as STNJET within ANOPP) was replaced with an improved model in 2009<sup>130-132</sup>. It is designated ST2JET within ANOPP. The newer model includes predictions for turbulent mixing noise and shock noise predictions for nozzles having either one or two streams (including inverted-velocity profiles), plugs, and chevrons. The ANOPP also includes the SAE jet noise module,<sup>88</sup> a modified SAE model for small engines,<sup>133</sup> Tam's shock-noise method,<sup>134-136</sup> and Pao's inverted velocity profile method<sup>137</sup>.

Additional jet-noise and jet-noise related prediction codes have been developed by, or under funding from, NASA. During the HSR program, HSRNOISE<sup>138</sup> was developed and includes mixer-ejector prediction capabilities<sup>139,140</sup>. Acoustic analogy-based prediction codes informed by Reynolds-Averaged Navier-Stokes (RANS) flow solutions have also been developed and are now part of the JeNo and Jet3D codes.<sup>141-144</sup> A formulation based on Goldstein's generalized acoustic analogy with source models based on experimental data<sup>145</sup> has also been developed<sup>146,147</sup>. The code has been recently updated and is now known as GAA-Jet. One NASA publication that stands out for the guidance provided on many noise prediction methods is that of Goldstein.<sup>148</sup> The theoretical work of Goldstein in aerodynamically generated sound for jets dates back to the early 1970s.<sup>149,150</sup>

Between 2006 and 2012, an assessment was undertaken of NASA's various acoustic analogy-based prediction codes and the Stone Jet module within ANOPP. Predictions were compared to data acquired in NASA's jet noise facilities. None of the models predicted all test cases within experimental uncertainties. EPNL could be off by several decibels using some of the prediction approaches.<sup>151</sup>

High-fidelity jet noise predictions using NASA's Launch Ascent and Vehicle Aerodynamics (LAVA) solver developed at NASA Ames Research Center have been recently undertaken.<sup>152-154</sup> The LAVA solver includes a hybrid RANS/Large Eddy Simulation (LES) capability and uses a permeable Ffowcs-Williams Hawkins surface for far-field noise predictions. Good agreement has been found between experimental and acoustic data acquired in NASA facilities and results obtained with the LAVA code.

### **C. Supersonic programs and projects**

On July 24, 1961, the FAA, Department of Defense (DoD), and NASA issued the "Commercial Supersonic Transport Aircraft Report," which concluded that a Mach 3 aircraft was feasible. Later that same year the three agencies agreed on a plan for research and study of the Supersonic Transport (SST) with the FAA responsible for program leadership. The establishment of a Supersonic Transport Steering Group, which would support efforts of the existing SST task group, was part of that plan. Announcements of supersonic transport developments by the Soviet Union (the Tu-144) followed in 1962 and by a consortium of the British and French governments (the Concorde) followed in 1963. To keep pace with foreign advancements, the US announced the SST program on July 5, 1963, and requests for proposals were released on August 15, 1963. The intent of the US program was to build what would be the next generation supersonic transport with target cruise speeds (Mach 2.7) well beyond that of the Concorde (Mach 2.04). The program was managed by the FAA with NASA as part of the evaluation teams.<sup>155</sup> One month following the request for proposals, results of NASA's Supersonic Commercial Air Transport (SCAT) feasibility studies were reported and concluded that significant research would be required for the development of a commercial Mach 3 aircraft.<sup>156</sup>

The SST program was organized in two parts with a design competition in phase I and a development program awarded to Boeing in 1968 for phase II. The Boeing concept would use GE4



turbojet afterburning engines. The program was terminated in 1971 when it was recognized that significant technological advances were required for the second-generation supersonic transport and none of the concepts would meet the new FAA noise regulation instituted in 1969. While the initial SST program had little noise research, a DOT follow-on program in 1972 had significant high-speed jet-noise reduction work, some of which was jointly funded by NASA.<sup>157</sup>

The SST work was transferred to NASA in 1972, originally named the Advanced Supersonic Technology (AST) program, renamed the Supersonic Cruise Aircraft Research (SCAR) program in 1974, and again renamed the Supersonic Cruise Research (SCR) program in 1979.<sup>155</sup> The name changes were to prevent the impression that NASA was developing an SST. The goals of these programs were aimed at addressing fundamental research barriers that were identified during the SST program. The engine research was managed through NASA Lewis working closely with engine manufacturers. Program funding ended in fiscal year 1981. A new concept, the variable cycle engine, was originally developed under SCR and then broken out as a separate program, the Variable-Cycle Engine (VCE) Component Program, during fiscal year 1975.<sup>155</sup> The VCE Component Program was renamed roughly two years later to VCE Technology Program.<sup>158</sup> Measurements by NASA were made in the Ames 40 x 80 Foot Wind Tunnel, the Ames Outdoor Static Test Facility, the F-106 testbed<sup>159</sup> (see Fig. 22), and scale-model facilities. Two conferences were held at Langley covering the SCR related work.<sup>160,161</sup>

Jet noise was recognized as the dominant noise source in the SCR and SCR-related programs, and noise reduction efforts focused on a combination of cycle and mechanical suppressors<sup>162</sup> as it



FIG. 22. The F-106 testbed.

was recognized that cycle alone would not meet FAA requirements. The approach was in stark contrast to the trends for subsonic commercial aviation at the time, where cycle alone was used to meet regulations. Early noise reduction concepts built on previous work, in part from NACA, and included multi-spoke, chute, and tube nozzles with and without scoops and acoustically treated shrouds<sup>163-166</sup> (see Figs. 23-25) and early versions of lobed nozzles.<sup>167,168</sup> Early studies found significant noise reduction was accompanied by significant thrust penalty. A moderate 5 EPNdB was achieved with 5% thrust loss for the chute suppressor and 10.5% thrust loss for the tube suppressor. Follow-on studies reduced the multi-tube thrust losses to 2 – 3 %, and adding an ejector provided some static thrust augmentation<sup>169</sup> although no noise suppression unless the ejector was lined. A combination of a multitube/multilobe mixer with an acoustically lined ejector produced up to 16 EPNdB with a 4.5 % thrust loss<sup>170</sup> relative to a fully mixed exhaust. Industry engine studies focused on inverted velocity profiles (IVP) using mechanical inversion or duct burning<sup>159,171</sup> and hardwall and acoustically treated ejectors.<sup>171</sup> The IVP resulted in a 4 - 6 PNdB reduction in the aft quadrant with greater reductions in the shock-noise dominated forward quadrant;<sup>172</sup> however, it was recognized that the IVP alone would not meet FAA noise regulations.<sup>173</sup> Advanced takeoff procedures including thrust modulation during roll, various cutback schemes, configuration changes (other landing gear retraction), and increased glide slopes were also pursued for noise reduction.<sup>174</sup> Investigations of

over-the-wing mounting for wing shielding benefits indicated that corrosion and sonic fatigue were problematic.<sup>175</sup> Fundamental studies showed the benefit of porous plugs for reducing shock-associated noise<sup>176-178</sup> and thermal shields for reducing high frequency noise in the peak jet-noise direction<sup>179</sup>.

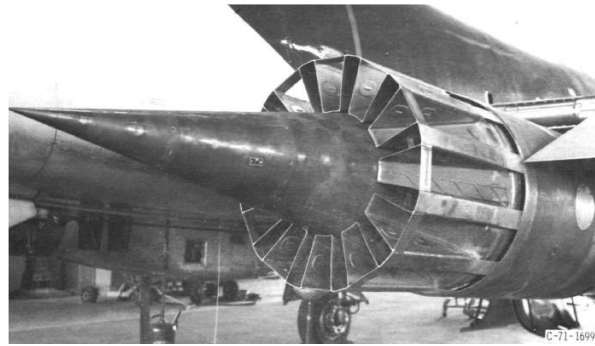

FIG. 23. A chute mixer tested during the SCR program. Reprinted with permission from R. R. Burley and A. L. Johns, NASA-TM-X-2918, National Aeronautics and Space Administration, Washington, DC (1974) (Ref. 164).



FIG. 24. A tube suppressor tested during the SCR program. Reprinted with permission from R. R. Burley and V. L. Head, NASA-TM-X-2919, National Aeronautics and Space Administration, Washington, DC (1974) (Ref. 165).

Following the conclusion of SCR, NASA awarded industry contracts to evaluate the potential for a future high-speed civil transport (HSCT) in 1986 and conducted complementary in-house studies.<sup>180,181</sup> The first phase of the contracted effort focused on market projections and the second on performance. Environmental constraints were not a part of the performance phase, and noise

would not be addressed until the final (third) phase. The second phase of the effort resulted in proposed propulsion concepts that included various turbojet and low-bypass turbofan concepts. Supersonic jet-noise suppression concepts were reviewed and evaluated based on the potential for meeting noise requirements for an HSCT.<sup>182</sup>

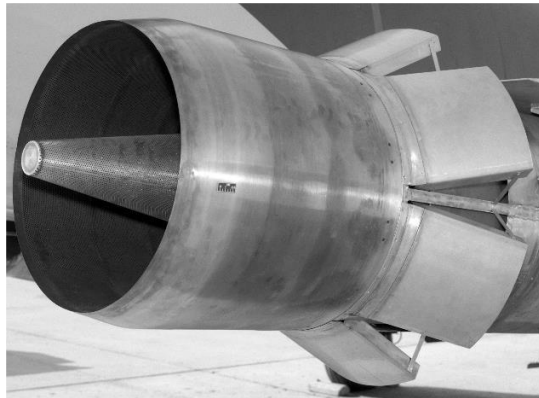

FIG. 25. A tube suppressor with an acoustic shroud tested during the SCR program.

Reprinted with permission from R. R. Burley and V. L. Head, NASA-TM-2919, National Aeronautics and Space Administration, Washington, DC (1974) (Ref. 165).

In 1987, National Aeronautics R & D Goals were released by the Office of Science and Technology Policy, which recommended that NASA and industry accelerate the development of promising technologies for long-distance efficient and environmentally compatible supersonic transports spurred by the interest in increased access to East Asia and the Pacific Basin.<sup>183</sup> Following these recommendations, the NASA Authorization Act of 1988 directed NASA to prepare a technology development validation plan to ensure the US would retain leadership in aeronautics research and technology. In 1990, the HSR program emerged and addressed one NASA aeronautics strategic thrust area at the time, which was aimed at resolving the critical environmental issues and establishing the technology for economic, high-speed air transportation. The initial HSR program goals for the HSCT included a Mach 2.4 cruise speed, a passenger capacity of 250 – 300, a range of 5000 nm with growth to 6500 nm, and introduction into the market in 2005.<sup>184</sup> Phase I of the HSR

effort focused on emissions and noise with noise levels of 15 – 20 PNdB below those for a reference conic nozzle. The noise reduction target was required for an HSCT to meet FAA regulations (Stage III at the time).<sup>185</sup> The HSR program became the era of the mixer-ejector driven by the required large noise reductions resulting from the low bypass ratio engine concepts selected to meet the mission goals. The selection of the mixer ejector was the result of a target jet exhaust velocity of 1400 ft/s, believed to be necessary for acceptable jet noise levels, and the realization that the weight and cruise drag of high-bypass turbofan engines that could achieve the desired jet velocity were unacceptably high.<sup>186</sup> System studies by the end of the HSR program focused on an ideal jet velocity, nozzle pressure ratio, and bypass ratio for the primary stream if the flow were fully expanded of 2360 ft/s, 3.43, and 0.6, respectively. The program was terminated in 1999 with final reports released up to 2005. Large-scale tests were planned with expected increased cost share from industry leading to aircraft demonstrations. During this time, there was pressure to reduce the budget for aeronautics research within the government, and industry decided to focus their efforts on subsonic aircraft. Another opportunity for commercial supersonic transports in the US ended just as it did in the early 1970s. Experimental research in the HSR program made extensive use of the APL facility at NASA Lewis and the LSAWT at NASA Langley.

The HSR program required significant research in chute/lobed mixers,<sup>187,188</sup> combination mixer and acoustically treated ejectors,<sup>189-193</sup> and tabs/chevrons<sup>102,194</sup> and it was believed that all of these technologies would need to be combined to meet program noise targets.<sup>186</sup> The Critical Propulsion Components (CPC) element of HSR, responsible for developing the propulsion component technologies to meet airport noise restrictions, culminated in two tests of the final nozzle configuration with a 1/7 model (designated the LSMS nozzle) tested at Boeing's LSAF and a 56.4% scale model (designated LSM nozzle) installed on an F100-PW-229 engine mounted on an engine stand.<sup>186</sup> The nozzle systems included a round-to-rectangular transition duct, a chute mixer, a lined

ejector, and chevrons. None of the models included a fan/core mixer, although it was realized that this additional nozzle component would be required for an actual HSCT application. The final configuration was known for its large, bulky size with the 56% model having a length of just under 12 ft (see Fig. 26). An alternate nozzle concept, a fluidic shield using fan on blade (FLADE) flow, was also investigated.<sup>195</sup> Accomplishments of the HSR program were highlighted in a review published in 2005.<sup>196</sup>

Throughout HSR, a series of flight tests with F-15, F-16, and F/A-18 aircraft (see Fig. 27) were conducted to acquire data for jet noise modeling and model validation.<sup>197,198</sup> Additionally, fundamental work explored nozzle types such as the rectangular beveled nozzle that showed noise directivity shifts (relative to a standard rectangular nozzle) that were thought to have the potential to provide an acoustic benefit if coupled with an ejector.<sup>199</sup>

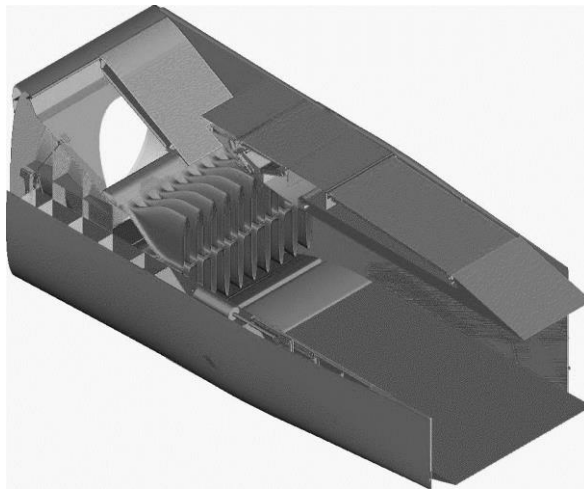

FIG. 26. A model of LSMS nozzle system used in the HSR program.

During the SCR and HSR programs, significant fundamental work on shock associated noise was conducted at NASA Langley and at NASA Lewis. The Quiet Flow Facility (QFF)<sup>200</sup> was used for much of the work at Langley and CW17 test cells were used at Lewis. Due to the simulated forward flight capabilities, the QFF was used to investigate flight effects. Initial broadband shock-associated noise (BBSN) experiments compared shock structure and noise characteristics of supersonic jets produced by convergent and convergent-divergent (CD) nozzles and looked at the applicability of existing broadband shock noise prediction methods of Harper-Bourne and Fisher<sup>201</sup>. Most of the data before these experiments were acquired for convergent nozzles and, therefore, only



FIG. 27. The F-15 Active aircraft used for forward-flight investigations.

looked at underexpanded jets.<sup>202</sup> One interesting aspect of this work was the documented increase in broadband noise when using a single tab to eliminate screech produced by a jet exhausting from a CD nozzle. Following this initial experiment, comprehensive databases for the shock-cell length and acoustic radiation from cold jets with and without forward flight were acquired and, toward the end of this period, showed relatively good agreement between predicted (using a new model by Tam<sup>203</sup>) and measured broadband shock-associated noise.<sup>204-207</sup> A broadband shock noise model was also developed from the numerical work of Pao and Salas,<sup>208</sup> which agreed with the scaling laws of Harper-Bourne and Fisher and showed important details of the vortex-shock interaction.<sup>209</sup>

Significant work was conducted on jet screech, tones that can be produced by imperfectly expanded supersonic jets, and is well documented in a review paper.<sup>210</sup> Work on screech also identified standing waves that extended into the shear layer.<sup>211</sup> In addition to screech and BBSN, transonic tones resulting from unsteady shocks in the divergent section of a CD nozzle acting as a diaphragm and creating a resonance between the shock and nozzle exit were also investigated.<sup>212</sup> Twin supersonic plume resonance was studied<sup>213</sup> and revealed fluctuating loads on an F-15 scale model that were believed to be responsible for a structural resonance in the aircraft.<sup>214</sup>

Another fundamental research area during the SCR and HSR programs was Mach wave emission in high-speed jets, originally associated with observable high-intensity waves in the near-field of jets and ultimately believed to be responsible for peak noise radiation. Oertel<sup>215</sup> was the first to identify three types of waves with different propagation speeds in high-temperature, high-speed supersonic jets. Two types of waves propagated supersonically and, therefore, could radiate Mach waves. At NASA, Mach wave emission was investigated experimentally and connected to instability theories developed during the same period, which related the development of large-scale coherent structures in the jet to peak acoustic radiation. Early work with supersonic cold jets mapped out the acoustic near field and the apparent origin of sound as well as documented mean velocity profiles and longitudinal velocity fluctuations in the shear layer.<sup>216</sup> This early experimental work was inspired by, and compared with, the instability theory of Morris and Tam.<sup>217</sup> A review paper highlighting supersonic jet-noise research followed shortly after.<sup>218</sup> Nearly a decade later, investigations focused on very high temperature jets characteristic of tactical fighter aircraft or second-generation space transport vehicles.<sup>219</sup> These studies used schlieren photography and acoustic measurements to document the occurrence of multiple types of Mach waves, some of which had emission angles that were consistent with the theory of Tam and Hu<sup>220</sup> developed a few years earlier to explain the multiple waves observed by Oertel. The studies also provided evidence that elliptic nozzles had the



potential to reduce Mach wave emissions (relative to round nozzles). Later numerical studies using the approach of Tam and Hu identified the instability modes associated with dominant acoustic radiation and appeared to reproduce experimental data at low Strouhal numbers.<sup>221</sup> Instability theory was extended to supersonic jets with inverted velocity profiles and showed the importance of high jet spreading rates for the outer shear layer to reduce peak noise levels.<sup>222</sup>

In 2006, the Supersonics (SUP) project in FAP was initiated and was the first project to include supersonic jet noise work since the conclusion of the HSR program in 1999. The SUP project set generational goals starting with smaller aircraft and increasing aircraft size over time. There was more support for this approach from industry, which had formed an alliance for developing supersonic business jets. Previous supersonic programs focused on larger and faster aircraft that created a large feasibility gap and impractical noise goals. The designations of N+1, N+2, and N+3 were used to organize research as was the case for corresponding Subsonic Fixed Wing (SFW) project at the time, although the designations had significantly different meanings in the two projects. For the SUP project, N+1 targeted technologies for a supersonic business class aircraft (6 – 20 passengers) and a technology maturation date of 2015. Meeting FAA Stage 4 was the airport noise goal of N+1. The N+2 research focused on a small supersonic airliner with 35 – 70 passengers and a technology maturation date of 2020. With the understanding that noise regulations become more stringent over time, the N+2 airport noise goal was set at 10 EPNdB below FAA Stage 4. The N+3 efforts focused on an efficient multi-Mach aircraft with 100 – 200 passengers and a technology maturation date of 2030. The airport noise target was 10 – 20 EPNdB cumulative below FAA Stage 4. In the early stages of the project, the work focused on the N+2 aircraft. While the jet-noise work is of interest here, it should be noted that the project focused heavily on sonic boom reduction. Today the supersonics project is the Commercial Supersonic Technology (CST) project and, due to

the expectation of a near-term entry into service supersonic business jet and an anticipated new FAA supersonic-aircraft noise regulation, the jet-noise work includes research for N+1 type aircraft.

The engines for supersonic aircraft need to be compact to meet performance and sonic boom goals but also need to have reduced exhaust velocities during takeoff and landing to meet airport noise goals. Emphasis has been placed on developing variable-cycle engines as in the SCR program. The military has considered a third stream that can be closed for cruise and effectively changes the engine bypass ratio. For commercial applications, a third stream provides the potential for several jet noise reduction technologies such as inverted velocity profiles, offset streams, and fluid shields. Contracts awarded by NASA to Lockheed and Boeing focused on studying the benefits of a variable cycle engine and GE and Rolls-Royce developed engine concepts aimed at meeting the goal of a 10-EPNdB cumulative noise reduction under Stage 4 regulations. Scale model tests were carried out in NATR to investigate mixer-ejector concepts (see Fig. 28) with a third stream and inverted velocity

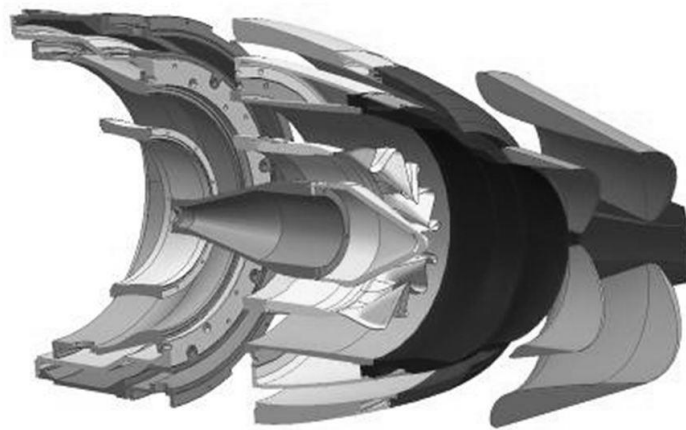

FIG. 28. The Rolls-Royce mixer-ejector concept investigated during NASA's N+2 studies.

profiles with a fluid shield.<sup>223</sup> Both concepts had degraded acoustic performance due to model flow separations, highlighting the need for continued research on multi-stream jet noise reduction concepts. Follow-on studies included surface elements to capture some installation effects.<sup>224</sup> Fundamental jet noise work during the SUP and CST projects included research on twin jets,<sup>225</sup>

offset multi-stream jets,<sup>226,227</sup> jet-surface interaction effects,<sup>228,229</sup> rectangular jets,<sup>230</sup> exhaust nozzles with aft decks,<sup>231</sup> chevrons,<sup>232,233</sup> and noise source mechanisms<sup>234,235</sup>.

The FAA and NASA have worked together for many years to provide technology assessments that help guide regulations. Thus far, commercial supersonic aircraft (the Concorde) have not been required to certify to subsonic airplane noise standards and, therefore, have been exempt from the ever-increasing stringencies that have been placed on subsonic transports. Additionally, these aircraft have been required to fly at subsonic speeds over land in the United States due to sonic boom. Due to renewed interest in commercial supersonic flight, NASA and the FAA, working through International Civil Aviation Organization (ICAO)'s Working Group 1 (WG1), initiated studies in 2016 to evaluate Landing Takeoff (LTO) noise from supersonic aircraft. NASA defined several Supersonic Technology Concept Aeroplanes (STCAs) that explored the design space for aircraft size, weight, cruise speed, and engine design around the N+1 SUP class vehicle. Jet noise was a primary driver that required uncertainty analysis around predictions used for system level codes and experimental data from both model scale and flight.<sup>236</sup> One of the concept vehicles (see Fig. 29), designated the "55-tonne STCA," was used extensively by ICAO to study community noise including alternative takeoff procedures such as programmed lapse rate (PLR) that trade noise levels between the two takeoff certification points.<sup>237,238</sup> PLR was a concept proposed during NASA's SCR program although not specifically identified as PLR at the time.<sup>174</sup> In 2020, the FAA announced the

first proposed noise standard for commercial supersonic aircraft through a Notice of Proposed Rulemaking.<sup>239</sup>

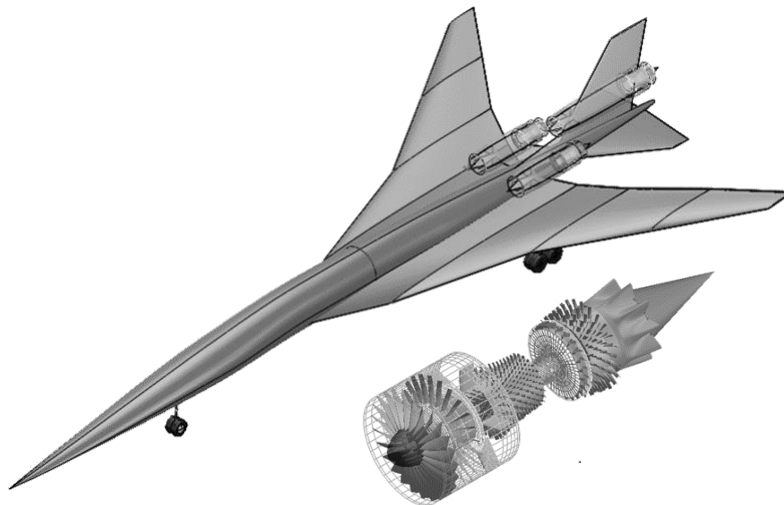

FIG. 29. The NASA 55-tonne Supersonic Technology Concept Aeroplane (STCA).

## V. CONCLUSIONS

There has been a long history of jet noise research at NASA dating back to the 1950s when turbojets were being developed for commercial airlines. The sustained effort over 70 years to reduce jet noise demonstrates the importance and difficulty in solving the problem. Since the inception of the work done under the NACA and early years of NASA, a common approach for reducing jet noise is to limit the jet exit velocity to speeds that provide acceptable noise levels. Early attempts to add mixers and suppressors resulted in thrust losses that were too severe to be implemented. This became a common theme for jet noise research that required acousticians to include aerodynamic performance in their assessments for noise-reduction concepts.

This paper has highlighted the various NASA-sponsored programs and projects that included jet noise research objectives. The research follows the progress made in the evolution of the turbofan engine with increasing bypass ratios that helped reduce jet velocities during takeoff. Until recently,

jet noise was included in all noise reduction research programs as it was an important source for the community. Now, with the introduction of turbofan engines with bypass ratios exceeding 12, the importance of jet noise has diminished for subsonic aircraft compared to other noise sources such as the fan, so much so that jet noise research is currently being done only in programs focused on supersonic transports. Many of the issues facing subsonic aircraft engines in the 1950s and 60s are now being revisited for supersonic applications, which illustrates how important it is not to neglect the progress and lessons learned from previous research. The paper shows how cyclical the development of noise reduction technologies has been as evidenced by chevron nozzles, which were derived from earlier research on mixing methods. Additionally, improvements in technologies such as computational methods and experimental techniques can make an old idea feasible for newer applications.

Future work in jet noise will probably be centered on supersonic transports. There have been several periods of interest in supersonic jets starting with the SST in 1968, then with the HSCT in the 1990s, and now with low-boom supersonic aircraft. The FAA has introduced the first proposal for noise regulations for supersonic transports that departs from levels required for the subsonic fleet. The challenge for jet-noise reduction remains as engines need to have high specific thrust to satisfy mission range requirements and small profiles for lower sonic boom. Solving the problem with higher bypass ratio engines is not feasible as the quest for higher cruise Mach numbers and larger, heavier aircraft push the envelope on speed. A lesson learned in commercial supersonic aircraft research is to grow the aircraft size and cruise speed from smaller vehicles rather than start with goals for large high-speed transports.

#### **ACKNOWLEDGEMENTS**

This work was supported by the Commercial Supersonic Technology project in the Advanced Air Vehicles Program. The authors would like to thank Mike Doty, Russell Thomas, Martha Brown,

James Bridges, Jeff Berton, Khairul Zaman, Stewart Leib, Jonathon Seidel, and Cetin Kiris for providing valuable input.

## REFERENCES

<sup>1</sup> V. P. Dawson, *Engines and Innovation: Lewis Laboratory and American Propulsion Technology*, NASA SP-4306 (U.S. Government Printing Office, Washington, DC, 1991), p. 65.

<sup>2</sup> R. E. Bilstein, *Orders of Magnitude: A History of the NACA and NASA 1915-1990*, NASA-SP-4406, (U.S. Government Printing Office, Washington, DC, 1989).

<sup>3</sup> G. P. Scriven, H. Richardson, J. S. Ames, M. L. Bristol, J. F. Hayford, C. F. Marvin, B. R. Newton, M. I. Pupin, S. Reber, S. W. Stratton and C. D. Walcott, "Aeronautics: First annual report of the National Advisory Committee for Aeronautics," NACA-AR-1, National Advisory Committee for Aeronautics, Washington, DC (1915).

<sup>4</sup> W. F. Durand, H. C. Richardson, J. S. Ames, M. L. Bristol, J. F. Hayford, C. F. Marvin, B. R. Newton, M. I. Pupin, G. P. Scriven, G. O. Squire, S. W. Stratton and C. D. Walcott, "Aeronautics: Second annual report of the National Advisory Committee for Aeronautics," NACA-AR-3, National Advisory Committee for Aeronautics, Washington, DC (1916).

<sup>5</sup> W. F. Durand, S. Stratton, J. S. Ames, V. E. Clark, J. F. Hayford, C. F. Marvin, B. R. Newton, M. I. Pupin, G. O. Squire, D. W. Taylor, J. H. Towers and C. D. Walcott, "Aeronautics: Third annual report of the National Advisory Committee for Aeronautics," NACA-AR-3, National Advisory Committee for Aeronautics, Washington, DC (1917).

<sup>6</sup> R. S. Arrighi, *Revolutionary Atmosphere. The Story of the Altitude Wind Tunnel and the Space Power Chambers*, NASA-SP-2010-4319 (U.S. Government Printing Office, Washington, DC, 2010).

<sup>7</sup> J. Hunsaker, A. V. Astin, D. W. Bronke, T. S. Combs, C. C. Laurence, L. C. Craigie, T. W. S. Davis, J. H. Doolittle, M. B. Gardner, R. M. Hazen, W. L. Littlewood, D. W. Nyrop, D. L. Putt, A. E. Raymond and W. G. W. F. W. Reichelderfer, "Thirty-eighth annual report on the National Advisory Committee for Aeronautics," NACA-AR-38, National Advisory Committee for Aeronautics, Washington, DC (1952).

<sup>8</sup> J. Hunsaker, D. W. Bronke, J. P. Adams, A. V. Astin, L. Carmichael, L. C. Craigie, J. H. Doolittle, L. Harrison, R. M. Hazen, W. Littlewood, R. B. Murray, R. A. Ofstie, D. L. Putt, A. E. Raymond, F. W. Reichelderfer, T. P. Wright and H. L. Dryden, "Thirty-ninth annual report on the National Advisory Committee for Aeronautics," NACA-AR-38, National Advisory Committee for Aeronautics, Washington, DC (1953).

<sup>9</sup> H. H. Hubbard, "A Survey of the aircraft-noise problem with special reference to its physical aspects," NACA-TN-2701, National Advisory Committee for Aeronautics, Washington, DC (1952).

<sup>10</sup> W. D. Coles and E. E. Callaghan, "Full-scale investigation of several jet-engine noise-reduction nozzles," NACA-TN-3974, National Advisory Committee for Aeronautics, Washington, DC (1957).

<sup>11</sup> E. E. Callaghan and W. D. Coles, "Investigations of far noise field of jets I - Effects of nozzle shape," NACA-TN-3590, National Advisory Committee for Aeronautics, Washington, DC (1956).

<sup>12</sup> L. W. Lassiter and H. Hubbard, "Experimental studies of noise from subsonic jets in still air," NACA-TN-2757, National Advisory Committee for Aeronautics, Washington, DC (1952).

<sup>13</sup> J. J. Dussling, "Historical overview and recent improvements at the NASA Glenn Research Center 8x6/9x15 Wind Tunnel Complex," NASA GRC-E-DAA-TN20102, National Aeronautics and Space Administration, Washington, DC (2015).

<sup>14</sup> H. H. Hubbard and L. W. Lassiter, "Experimental studies of jet noise," *J. Acoust. Soc.* **25**(3), 381-384 (1953).

<sup>15</sup> L. W. Lassiter and H. H. Hubbard, "Some results of experiments relating to the generation of noise in jets," *J. Acoust. Soc. Am.* **27**(3), 431-437 (1955).

<sup>16</sup> M. J. Lighthill, "On sound generated aerodynamically. I. General theory," *Proc. R. Soc. Lond. A* **211**, 564-587 (1952).

<sup>17</sup> L. W. Lassiter and H. H. Hubbard, "The near noise field of static jets and some model studies of devices for noise reduction," NACA-TN-3187, National Advisory Committee for Aeronautics, Washington, DC (1954).

<sup>18</sup> W. L. Howes, E. E. Callaghan, W. D. Coles and H. R. Mull, "Near noise field of a jet-engine exhaust," NACA-TR-1338, National Advisory Committee for Aeronautics, Washington, DC (1957).

<sup>19</sup> H. S. Ribner, "Shock-turbulence interaction and the generation of noise," NACA-TN-3255, National Advisory Committee for Aeronautics, Washington, DC (1954).

<sup>20</sup> W. D. Coles and E. E. Callaghan, "Investigation of far noise field of jets II - Comparison of air jets and jet engines," NACA-TN-3591, National Advisory Committee for Aeronautics, Washington, DC (1956).

<sup>21</sup> E. E. Callaghan and W. D. Coles, "Far noise field of air jets and engines," NACA-TR-1329, National Advisory Committee for Aeronautics, Washington, DC (1957).

<sup>22</sup> R. Westley and G. M. Lilley, "An investigation of the noise field from a small jet and methods for its reduction," Report No. 53, The College of Aeronautics, Cranfield, UK (1952).



- <sup>23</sup> F. B. Greatrex, "Jet noise," in *Proceedings of the Fifth International Aeronautical Conference*, Los Angeles, CA (June 20-23, 1955).
- <sup>24</sup> E. E. Callaghan, W. Howes and W. North, "Tooth-type noise-suppression devices on a full-scale axial-flow turbojet engine," NACA RM E54B01, National Advisory Committee for Aeronautics, Washington, DC (1954).
- <sup>25</sup> W. J. North, "Summary evaluation of toothed-nozzle attachments as a jet-noise-suppression device," NACA-TN-3516, National Advisory Committee for Aeronautics, Washington, DC (1955).
- <sup>26</sup> W. D. Coles and E. E. Callaghan, "Full-scale investigations of several jet engine noise-reduction nozzles," NACA-TN-3974, National Advisory Committee for Aeronautics, Washington, DC (1957).
- <sup>27</sup> C. C. Ciepluch, W. J. North, W. D. Coles and R. J. Antl, "Acoustic, thrust, and drag characteristics of several full-scale noise suppressors for turbojet engines," NACA-TN-4261, National Advisory Committee for Aeronautics, Washington, DC (1958).
- <sup>28</sup> W. J. North and W. D. Coles, "Effect of exhaust-nozzle ejectors on turbojet noise generation," NACA-TN-3573, National Advisory Committee for Aeronautics, Washington, DC (1955).
- <sup>29</sup> A. Powell, "The influence of exit velocity profile on the noise of a jet," *The Aeronaut. Quart.* **4**(4), 341-360 (1954).
- <sup>30</sup> W. D. Coles and E. E. C. J. A. Mihalow, "Turbojet engine noise reduction with mixing nozzle-ejector combinations," NACA-TN-4317, National Advisory Committee for Aeronautics, Washington, DC (1958).

<sup>31</sup> W. J. North, "Transonic drag of several jet-noise suppressors," NACA-TN-4269, National Advisory Committee for Aeronautics, Washington, DC (1958).

<sup>32</sup> W. D. Coles and W. J. North, "Screen-type noise reduction devices for ground running of turbojet engines," NACA-TN-4033, National Advisory Committee for Aeronautics, Washington, DC (1957).

<sup>33</sup> M. C. Kurbjun, "Limited investigation of noise suppression by injection of water into exhaust of afterburning jet engine," NACA-RM-L57L05, National Advisory Committee for Aeronautics, Washington, DC (1958).

<sup>34</sup> E. E. Callaghan and W. D. Coles, "Investigation of jet-engine noise reduction by screens located transversely across the jet," NACA-TN-3452, National Advisory Committee for Aeronautics, Washington, DC (1955).

<sup>35</sup> The Port of New York Authority, "Annual Report", The Authority, New York (1958).

<sup>36</sup> K. D. Kryter, "Scaling human reactions to the sound from aircraft," *J. Acoust. Soc. Am.* **31**(11), pp. 1415-1429, 1959.

<sup>37</sup> K. D. Kryter and K. S. Pearsons, "Some effects of spectral content and duration on perceived noise levels," *J. Acoust. Soc. Am.* **35**(6), 866-883 (1963).

<sup>38</sup> W. D. Coles, "Jet-engine exhaust noise from slot nozzle," NASA-TN-D-60, National Aeronautics and Space Administration, Washington, DC (1959).

<sup>39</sup> V. G. Rollin, "Effect of multiple-nozzle geometry on jet-noise generation," NASA-TN-D-770, National Aeronautics and Space Administration, Washington, DC (1961).

<sup>40</sup> W. D. Coles, J. A. Mihalow and W. H. Swann, "Ground and in-flight acoustic performance characteristics of jet-aircraft exhaust noise suppressors," NASA-TN-D-874, National Aeronautics and Space Administration, Washington, DC (1961).

<sup>41</sup> W. L. Howes, "Similarity of far Noise fields of jets," NASA-TR-R-52, National Aeronautics and Space Administration, Washington, DC (1960).

<sup>42</sup> Office of Science and Technology, "Alleviation of jet aircraft noise near airports, a report of the jet aircraft noise panel," U.S. Government Printing Office, Washington, DC (1966).

<sup>43</sup> Public Law 90-411-July 21, 1968, "An act to amend the Federal Aviation Act of 1958 to require aircraft noise abatement regulation, and for other purposes," U.S. Government Printing Office, Washington, DC (1968).

<sup>44</sup> J. F. McBride, "Quiet engine program preliminary engine design and aircraft integration," in *Progress of NASA Research Relating to Noise Alleviation of Large Subsonic Jet Aircraft*, NASA-SP-189, U.S. Government Printing Office, Washington, DC (1968), pp. 263 - 272.

<sup>45</sup> G. T. Kantargos and J. M. Cawthorn, "Effects of temperature on noise of bypass jets as measurement in the langley noise research facility," NASA-TN-D-2378, National Aeronautics and Space Administration, Washington, DC (1964).

<sup>46</sup> J. J. Kramer, B. R. Leonard and C. E. Feiler, "Low-noise propulsion systems for subsonic transports," NASA-TM-X-52640, National Aeronautics and Space Administration, Washington, DC (1969).

<sup>47</sup> J. H. Lewis, "Quiet engine definition program final report," NASA-CR-72457, Vol. 1, National Aeronautics and Space Administration, Washington, DC (1968).

<sup>48</sup> Allison Division, General Motors, "Final report quiet engine definition program," NASA-CR-72458, National Aeronautics and Space Administration, Washington, DC (1968).

<sup>49</sup> J. J. Kramer and F. J. Montegani, "The NASA Quiet Engine Program," NASA-TM-X-67988, National Aeronautics and Space Administration, Washington, DC (1972).

<sup>50</sup> W. L. Copeland, D. A. Hilton, V. Huckel, A. C. Dibble and D. J. Magliere, "Noise measurements evaluations of various take-off -climbout profiles of a four-engine turbojet transport airplane," NASA-TN-D-3715, National Aeronautics and Space Administration, Washington, DC (1966).

<sup>51</sup> L. Copeland, "Two methods of evaluating climbout noise," in *Progress of NASA Research Relating to Noise Alleviation of Large Subsonic Jet Aircraft*, NASA-SP-189, U.S. Government Printing Office, Washington, DC (1968), pp. 369 - 376.

<sup>52</sup> T. G. Ayers, "The NASA Advanced Transport Technology Program," SAE 720319, SAE International, Warrendale, PA (1972).

<sup>53</sup> L. J. Williams, "Trasonic transport study," NASA-TM-X-62156, National Aeronautics and Space Administration, Washington, DC (1972).

<sup>54</sup> General Electric Company, "Propulsion system studies for an advanced high subsonic long range jet commercial transport aircraft," NASA-CR-121016, National Aeronautics and Space Administration, Washington, DC (1972).

<sup>55</sup> G. L. Brines, "Studies for determining the optimum propulsion system characteristics for use in a long range transport aircraft," NASA-CR-120950, National Aeronautics and Space Administration, Washington, DC (1972).

<sup>56</sup> M. A. Compagnon, "A study of engine variable geometry systems for an advanced high subsonic long range commercial aircraft," NASA-CR-134495, National Aeronautics and Space Administration, Washington, DC (1973).

<sup>57</sup> G. A. Champagne, "Study of unconventional propulsion system concepts for use in a long range transport," NASA-CR-121242, National Aeronautics and Space Administration, Washington, DC (1973).

<sup>58</sup> R. P. Woodward and G. L. Minner, "Low-frequency rear quadrant noise of a turbojet engine with exhaust duct muffling," NASA-TM-X-2718, National Aeronautics and Space Administration, Washington, DC (1973).

<sup>59</sup> DOT-NASA, "Civil aviation research and development policy study," NASA-SP-265, National Aeronautics and Space Administration, Washington, DC (1971).

<sup>60</sup> C. Ciepluch, "QCSEE program background," in *Quiet, Powered-Lift Propulsion: A Conference Held at Lewis Research Center, Cleveland, Ohio, November 14-15, 1978*, NASA-CP-2077, National Aeronautics and Space Administration, Washington, DC (1978), pp. 1 – 15.

<sup>61</sup> H. C. Quigley and R. C. Innis, "A flight investigation of the STOL characteristics of an augmented jet flap STOL research aircraft," NASA-TM-X-62334, National Aeronautics and Space Administration, Washington, DC (1974).

<sup>62</sup> M. D. Shovlin and J. A. Cochrane, "An overview of the Quiet Short-Haul Research Aircraft Program," in *Quiet, Powered-Lift Propulsion: A Conference Held at Lewis Research Center, Cleveland, Ohio, November 14-15, 1978*, NASA-CP-2077, National Aeronautics and Space Administration, Washington, DC (1978).

- <sup>63</sup> R. C. Savin, T. L. Galloway, D. E. Wilcox, G. C. Kenyon, M. D. Ardema and M. H. Waters, "Summary of recent short-haul systems studies," NASA-TM-X-3010, National Aeronautics and Space Administration, Washington, DC (1975).
- <sup>64</sup> A. P. Adamson, "QCSEE description," in *Quiet, Powered-Lift Propulsion: A Conference Held at Lewis Research Center, Cleveland, Ohio, November 14-15, 1978*, NASA-CP-2077, National Aeronautics and Space Administration, Washington, DC (1978), pp. 17 – 29.
- <sup>65</sup> I. J. Loeffler, "QCSEE engine and wing tests at NASA," in *Quiet, Powered-Lift Propulsion: A Conference Held at Lewis Research Center, Cleveland, Ohio, November 14-15, 1978*, NASA-CP-2077, National Aeronautics and Space Administration, Washington, DC (1978), pp. 249 – 261.
- <sup>66</sup> M. R. Fink and W. A. Olsen, "Comparison of predictions and under-the-wing EBF noise data," in *Proceedings of the 3<sup>rd</sup> AIAA Aero-Acoustics Conference*, AIAA-76-501, Palo Alto, CA (July 20-23, 1976).
- <sup>67</sup> J. H. Goodykoontz, J. M. Wagner and N. B. Sargent, "Noise measurements for various configurations of a model of a mixer nozzle - externally blown flap system," NASA-TM-X-2776 (1973).
- <sup>68</sup> J. H. Goodykoontz and R. G. Dorsch, "Acoustic Characteristics of Externally Blown Flap Systems with Mixer Nozzles," NASA-TM-X-71499, National Aeronautics and Space Administration, Washington, DC (1977).
- <sup>69</sup> N. E. Samanich, L. J. Heidelberg and W. L. Jones, "Effect of exhaust nozzle configuration on aerodynamic and acoustic performance of an externally blow flap system wiith a quiet 6:1 bypass ratio engine," in *Proceedings of the AIAA/SAE 9<sup>th</sup> Propulsion Conference*, AIAA-73-1217, Las Vegas, NV (November 5-7, 1973).

<sup>70</sup> B. Clark, R. Dorsch and M. Reshotko, "Flap noise prediction method for a powered lift system," in *Proceedings of the AIAA Aero-Acoustics Conference*, AIAA-73-1028, Seattle, WA (October 15-17, 1973).

<sup>71</sup> R. G. Dorsch, B. J. Clark and M. Reshotko, "Interim prediction method for externally blown flap noise," NASA-TM-X-71768, National Aeronautics and Space Administration, Washington, DC (1975).

<sup>72</sup> M. R. Fink, "A method for calculating externally blow flap noise," NASA-CR-2954, National Aeronautics and Space Administration, Washington, DC (1978).

<sup>73</sup> U. von Glahn and D. Groesbeck, "Interim noise correlation for some OTW configurations," NASA-TM-73746, National Aeronautics and Space Administration, Washington, DC (1977).

<sup>74</sup> D. J. McKinzie and R. J. Burns, "Analysis of noise produced by jet impingement near the trailing edge of a flat and a curved plate," NASA-TM-X-3171, National Aeronautics and Space Administration, Washington, DC (1975).

<sup>75</sup> W. L. Jones and L. J. Heidelberg, "Investigation of noise from full-scale high bypass engine and blown flap system," NASA-TM-X-71539, National Aeronautics and Space Administration, Washington, DC (1974).

<sup>76</sup> M. Reshotko, W. A. Olsen and R. G. Dorsch, "Preliminary noise tests of the engine-over-the-wing concept II: 10°-20° flap position," NASA-TM-X-68104, National Aeronautics and Space Administration, Washington, DC (1972).

- <sup>77</sup> U. von Glahn and D. Groesbeck, "Assessment at full scale of exhaust nozzle-to-wing size on STOL-OTW acoustic characteristics," NASA-TM-79279, National Aeronautics and Space Administration, Washington, DC (1979).
- <sup>78</sup> R. R. Burley, "Flight velocity effects on the jet noise of several variations of a 104-tube suppressor nozzle," NASA-TM-X-3049, National Aeronautics and Space Administration, Washington, DC (1974).
- <sup>79</sup> F. W. Burcham, Jr. and P. L. Lasagna, "Measurements and predictions of flyover and static noise of a TF30 after burning turbofan engine," NASA-TP-1372, National Aeronautics and Space Administration, Washington, DC (1978).
- <sup>80</sup> J. A. Atencio, Jr., "Wind tunnel measurements of forward speed effects on jet noise from suppressor nozzles and comparison with flight test data," in *Proceedings of the AIAA 8<sup>th</sup> Fluid and Plasma Dynamics Conference*, AIAA-75-870, Hartford, CT (June 16-18, 1975).
- <sup>81</sup> F. G. Strout and A. Atencio, Jr., "Flight effects on JT8D engine jet noise measured in a 40 x 80 tunnel," *J. Aircraft* **14**(8), 762 - 767 (1977).
- <sup>82</sup> U. von Glahn, D. Groesbeck and J. Goodykoontz, "Velocity decay and acoustic characteristics of various nozzle geometries in forward flight," in *Proceedings of the AIAA 6<sup>th</sup> Fluid and Plasma Dynamics Conference*, AIAA-73-629, Palm Spring, CA (July 16-18, 1973).
- <sup>83</sup> J. C. Yu and N. R. Dixon, "An experimental study of sound radiation from a subsonic jet in simulated motion," in *Proceedings of the 17<sup>th</sup> Aerospace Sciences Meeting*, AIAA-79-0185, New Orleans, LA (January 15-17, 1979).



<sup>84</sup> U. Von Glahn and J. Goodykoontz, "Forward velocity effects on jet noise with dominant internal noise source," NASA-TM-X-71438, National Aeronautics and Space Administration, Washington, DC (1973).

<sup>85</sup> K. K. Ahuja and B. J. Tester, "The free jet as a simulator of forward velocity effects on jet noise," NASA-CR-3056, National Aeronautics and Space Administration, Washington, DC (1978).

<sup>86</sup> T. D. Norum, "A comparison of the noise produced by a small jet on a moving vehicle with that in a free jet," NASA-TP-1326, National Aeronautics and Space Administration, Washington, DC (1978).

<sup>87</sup> J. R. Stone and F. J. Montegani, "An improved prediction method for the noise generated in flight by circular jets," NASA-TM-81470, National Aeronautics and Space Administration, Washington, DC (1980).

<sup>88</sup> SAE Aerospace, "Gas turbine jet exhaust noise prediction," SAE ARP 876F, SAE International, Warrendale, PA (2013).

<sup>89</sup> M. D. Bowles, *The Apollo of Aeronautics: NASA's Aircraft Energy Efficiency Program 1973 - 1987*, NASA-SP-2009-574, U.S. Government Printing Office, Washington, DC (2010).

<sup>90</sup> A. P. Kuchar and R. Chamberlin, "Comparison of full-scale engine and subscale model performance of mixed flow exhaust system for energy efficient engine (E3) propulsion system," in *Proceedings of the AIAA 22<sup>nd</sup> Aerospace Sciences Meeting*, AIAA-84-0283, Reno, NV (January 9-12, 1984).

<sup>91</sup> K. B. M. Q. Zaman and J. C. Yu, "Power spectral density of subsonic jet noise," *J. Sound and Vib.* **98**(4), 519 - 537 (1985).

<sup>92</sup> H. A. Kumasaka, M. M. Martinez and D. S. Weir, "Definition of 1992 technology aircraft noise levels and the methodology for assessing airplane noise impact of component noise reduction concepts," NASA-CR-198298, National Aeronautics and Space Administration, Washington, DC (1996).

<sup>93</sup> J. K. C. Low, "Ultra-high bypass ratio jet noise," NASA-CR-195394, National Aeronautics and Space Administration, Washington, DC (1994).

<sup>94</sup> R. Soeder, S. Wnuk and R. Loew, "Aero-Acoustic Propulsion Laboratory Nozzle Acoustic Test Rig user manual," NASA/TM-2006-212939, National Aeronautics and Space Administration, Washington, DC (2006).

<sup>95</sup> M. Salikuddin, R. R. Babbit, H. Shin, S. Wisler, B. A. Janardan and R. K. Majjigi, "Acoustic laser Doppler anemometer results for confluent and 12-lobed E3 mixer exhaust system for subsonic jet noise reduction," NASA CR-2002-211597, National Aeronautics and Space Administration, Washington, DC (2002).

<sup>96</sup> V. Mengle and W. Dalton, "Lobed mixer design for noise suppression acoustics and aerodynamic test data analysis," NASA CR-2002-210823, National Aeronautics and Space Administration, Washington, DC (2002).

<sup>97</sup> J. Low, P. Schweiger, P. J. Premo and T. Barber, "Advanced subsonic technology (AST) separate-flow high-bypass ratio nozzle noise reduction program test report," NASA CR-2000-210040, National Aeronautics and Space Administration, Washington, DC (2000).

<sup>98</sup> B. Janardan, G. Fogg, J. Barter, S. Martens, P. Gliebe and V. Mengle, "AST critical propulsion and noise reduction technologies for future commercial subsonic engines - separate-flow exhaust

systems noise reduction concept evaluation," NASA CR-2000-210039, National Aeronautics and Space Administration, Washington, DC (2000).

<sup>99</sup> N. Saiyed, K. Mikkelsen and J. Bridges, "Acoustic and thrust of separate-flow exhaust nozzles with mixing devices for high-bypass ratio engines," NASA TM-2000-209948, National Aeronautics and Space Administration, Washington, DC (2000).

<sup>100</sup> D. S. Weir, "Engine validation of noise reduction concepts - separate flow nozzles," in *Proceedings of the 42<sup>nd</sup> AIAA Aerospace Sciences Meeting and Exhibit*, AIAA-2004-188, Reno, NV (January 5-8, 2004).

<sup>101</sup> C. Brown and J. Bridges, "An analysis of model scale data transformation to full scale flight using chevron nozzles," NASA-TM-2003-212732, National Aeronautics and Space Administration, Washington, DC (2003).

<sup>102</sup> K. B. M. Q. Zaman, J. E. Bridges and D. L. Huff, "Evolution from 'tabs' to 'chevron technology' - a review," *Int. J. Aeroacoustics* **10**(5), 687-712 (2011).

<sup>103</sup> NASA, "Reducing aircraft noise to improve our quality of Life: NASA's Quiet Aircraft Technology program," FS-2002-09-73-LaRC, National Aeronautics and Space Administration, Washington, DC (2002).

<sup>104</sup> NASA, "Langley Research Center Facilities," NASA-TM-109685, National Aeronautics and Space Administration, Washington, DC (1993).

<sup>105</sup> B. Henderson, T. Norum and J. Bridges, "An MDOE assessment of nozzle vanes for high Bypass ratio jet noise reduction," in *Proceedings of the 12<sup>th</sup> AIAA/CEAS Aeroacoustics Conference*, AIAA-2006-2543, Cambridge, MA (May 8-10, 2006).

- <sup>106</sup> T. L. Turner, R. H. Cabell, R. J. Cano and G. A. Fleming, "Design, fabrication and testing of a SMA hybrid composite jet engine chevron," in *Proceedings of the SPIE 13th Annual International Symposium Smart Structures and Materials*, SPIE 6173-49, San Diego, CA (February 26-March 2, 2006).
- <sup>107</sup> T. D. Norum, "Reductions in multi-component jet noise by water injection," in *Proceedings of the 10th AIAA/CEAS Aeroacoustics Conference*, AIAA-2004-2976, Manchester, UK (May 10-12, 2004).
- <sup>108</sup> B. Henderson, "Fifty years of fluidic injection for jet noise reduction," *Int. J. of Aeroacoustics* **9**(1), 91 - 122 (2010).
- <sup>109</sup> K. W. Kinzie and D. B. Schein, "Experiments and analysis of distributed exhaust nozzles," in *Proceedings of the 8th AIAA/CEAS Aeroacoustics Conference & Exhibit*, AIAA-2002-2555, Breckenridge, CO (June 17-19, 2002).
- <sup>110</sup> K. W. Kinzie and D. B. Schein, "A method for estimating noise from full-scale distributed exhaust nozzles," in *Proceedings of the 10th AIAA/CEAS Aeroacoustics Conference*, AIAA-2004-2876, Manchester, UK (May 10-12, 2004).
- <sup>111</sup> J. Bridges and M. Wernet, "Measurements of Aeroacoustic Sound Source in Hot Jets," in NASA/TM-2004-212508 (2004).
- <sup>112</sup> J. Bridges and C. A. Brown, "A parametric testing of the chevrons on single flow hot jets," NASA/TM-2004-213107, National Aeronautics and Space Administration, Washington, DC (2004).
- <sup>113</sup> S. S. Lee and J. Bridges, "Phase-array measurements of single flow hot jets," NASA/TM-2005-213826, National Aeronautics and Space Administration, Washington, DC (2005).

<sup>114</sup> R. H. Thomas and K. W. Kinzie, "Jet-pylon interaction of high bypass ratio separate flow nozzle configurations," in *Proceedings of the 10<sup>th</sup> AIAA/CEAS Aeroacoustics Conference*, AIAA-2004-2827, Manchester, UK (May 10-12, 2004).

<sup>115</sup> M. J. Doty, B. S. Henderson and K. W. Kinzie, "Turbulence measurements of separate-flow nozzles with pylon interaction using particle image velocimetry," *AIAA J.* **45**(6), 1281 - 1289 (2007).

<sup>116</sup> W. Herkes, R. Olsen and S. Uellenberg, "The Quiet Technology Demonstrator Program: Flight validation of airplane noise-reduction concepts," in *Proceedings of the 12<sup>th</sup> AIAA/CEAS Aeroacoustics Conference*, AIAA-2006-2720, Cambridge, MA (May 10-12, 2006).

<sup>117</sup> E. Nesbitt, V. Mengle, B. Czech, B. Callender, and R. Thomas, "Flight test results for uniquely tailored propulsion-airframe aeroacoustic chevrons: Community noise," in *Proceedings of the 12<sup>th</sup> AIAA/CEAS Aeroacoustics Conference*, AIAA-2006-2438, Cambridge, MA (May 10-12, 2006).

<sup>118</sup> D. L. Huff, "NASA Glenn's contributions to aircraft engine noise research," NASA/TP-2013-217818, National Aeronautics and Space Administration, Washington, DC (2013).

<sup>119</sup> C. Brown, J. Bridges and B. Henderson, "Offset stream technology test - summary of results," in *Proceedings of the 13<sup>th</sup> AIAA/CEAS Aeroacoustics Conference*, AIAA-2007-3664, Rome, Italy (May 21-23, 2007).

<sup>120</sup> J. Bridges and M. P. Wernet, "Validating large-eddy simulation for jet aeroacoustics," *J. Propulsion and Power* **28**(2), 226 - 234 (2012).

<sup>121</sup> S. L. Heath, T. F. Brooks, F. V. Hucheson, M. J. Doty, C. J. Bahr, D. Hoad, L. Becker, W. M. Humphrey, C. L. Burley, D. Stead, D. S. Pope, T. B. Spalt, D. H. Kuchta, G. E. Plassman and J. A.

Moen, "NASA hybrid wing aircraft aeroacoustic test documentation report," NASA/TM-2016-219185, National Aeronautics and Space Administration, Washington, DC (2016).

<sup>122</sup> M. J. Doty, T. F. Brooks, C. L. Burley, C. J. Bahr and D. S. Pope, "Jet noise shielding provided by a hybrid wing body aircraft," in *Proceedings of the 20<sup>th</sup> ALAA/CEAS Aeroacoustics Conference*, AIAA-2014-2625, Atlanta, GA (June 16-20, 2014).

<sup>123</sup> R. H. Thomas, M. J. Czech and M. J. Doty, "High bypass ratio jet noise reduction and installation effects including shielding effectiveness," in *Proceedings of the 51<sup>st</sup> Aerospace Sciences Meeting*, AIAA-2013-0541, Grapevine, TX (2013).

<sup>124</sup> J. R. Stone, "Interim prediction method for jet noise," NASA-TM-X-71618, National Aeronautics and Space Administration, Washington, DC (1974).

<sup>125</sup> R. G. Huff, B. J. Clark and R. G. Dorsch, "Interim prediction method for low frequency core engine noise," NASA-TM-X-71627, National Aeronautics and Space Administration, Washington, DC (1974).

<sup>126</sup> M. F. Heidmann, "Interim prediction method for fan and compressor source noise," NASA-TM-X-71763, National Aeronautics and Space Administration, Washington, DC (1975).

<sup>127</sup> E. A. Krejsa and M. F. Valerino, "Interim prediction method for turbine noise," NASA-TM-X-73566, National Aeronautics and Space Administration, Washington, DC (1976).

<sup>128</sup> J. R. Stone, "An empirical model for inverted-velocity profile jet noise prediction," NASA-TM-X-73838, National Aeronautics and Space Administration, Washington, DC (1977).

- <sup>129</sup> J. R. Stone, C. L. Zola and B. J. Clark, "An improved model for conventional and inverted-velocity-profile coannular jet noise," in *Proceedings of the 37<sup>th</sup> AIAA Aerospace Sciences Meeting and Exhibit*, AIAA-99-0078, Reno, NV (January 11-14, 1999).
- <sup>130</sup> J. R. Stone, E. A. Krejsa and B. J. Clark, "Jet noise modeling for coannular nozzles including the effects of chevrons," NASA/CR- 2003-212522, National Aeronautics and Space Administration, Washington, DC (2003).
- <sup>131</sup> J. R. Stone, E. A. Krejsa and B. J. Clark, "Jet noise modeling for supersonic business jet application," NASA/CR-2004-212984, National Aeronautics and Space Administration, Washington, DC (2004).
- <sup>132</sup> J. R. Stone, E. A. Krejsa, B. J. Clark and J. J. Berton, "Jet noise modeling for suppressed and unsuppressed aircraft in simulated flight," NASA/TM-2009-215524, National Aeronautics and Space Administration, Washington, DC (2009).
- <sup>133</sup> J. Hough and D. Weir, "Small Engine Technology (SET) - Task 13 ANOPP noise prediction for small engines: Jet, core, and turbine module revisions," Allied Signal Engines Report No. 21-9655, Allied Signals, Morristown, NJ (1997).
- <sup>134</sup> C. K. W. Tam, "Broadband shock-associated noise of moderately imperfectly expanded supersonic jets," *J. Sound and Vib.* **140**(1), 55-71 (1990).
- <sup>135</sup> C. K. W. Tam, "Broadband shock-associated noise of supersonic jets measured by a ground observer," in *Proceedings of the 30<sup>th</sup> Aerospace Sciences Meeting & Exhibit*, AIAA-92-0502, Reno, NV (January 6-9, 1992).

- <sup>136</sup> C. K. W. Tam and N. N. Reddy, "A prediction method for broadband shock associated noise from supersonic rectangular jets," in *Proceedings NOISE-CON 93*, Williamsburg, VA (May 2–5, 1993), pp. 135-140.
- <sup>137</sup> S. P. Pao, "A correlation of Mixing Noise from Coannular Jets with Inverted Flow Profiles," NASA TP-1301, National Aeronautics and Space Administration, Washington, DC (1979).
- <sup>138</sup> J. W. Rawls, Jr. and J. C. Yeager, "High Speed Research Noise Prediction Code (HSRNOISE) user's and theoretical manual," NASA/CR-2004-213014, National Aeronautics and Space Administration, Washington, DC (2004).
- <sup>139</sup> K. Viswanathan and H. Y. Lu, "An empirical jet noise prediction procedure for rectangular mixer-ejector nozzles," Boeing Document No. D6-82061, The Boeing Commercial Airplane Group, Seattle, WA (1997).
- <sup>140</sup> J. R. Stone and B. J. Clark, "2-D mixer ejector nozzle noise analysis and prediction code development," HSR/CPC Program Coordination Memorandum GE99-034-N, Modern Technologies Corp., Knoxville, TN (1999).
- <sup>141</sup> A. Khavaran, J. Bridges and N. Georgiadis, "Prediction of turbulence-generated noise in unheated jets: Part 1: JeNo technical manual (Version 1.0)," NASA/TM-2005-213827, National Aeronautics and Space Administration, Washington, DC (2005).
- <sup>142</sup> A. Khavaran, J. D. Wolter and L. D. Koch, "Prediction of turbulence-generated noise in unheated jets: Part 2: JeNo users' manual (Version 1.0)," NASA/TM-2009-213827/PART2, National Aeronautics and Space Administration, Washington, DC (2009).



- <sup>143</sup> A. Khavaran and J. Bridges, "An empirical temperature variance source model in heated jets," NASA/TM-2012-217743, National Aeronautics and Space Administration, Washington, DC (2012).
- <sup>144</sup> C. A. Hunter and R. H. Thomas, "Development of a jet noise prediction method for installed jet configurations," in *Proceedings of the 9<sup>th</sup> AIAA/CEAS Aeroacoustics Conference and Exhibit*, AIAA-2003-3169, Hilton Head, SC (May 12-14, 2003).
- <sup>145</sup> M. E. Goldstein, "A generalized acoustic analogy," *J. Fluid Mech* **488**, 315 - 333 (2003).
- <sup>146</sup> M. E. Goldstein and S. J. Leib, "The aeroacoustics of slowly diverging supersonic jets," *J. Fluid Mech.* **600**, 291 - 337 (2008).
- <sup>147</sup> S. J. Leib and M. E. Goldstein, "Hybrid source model for predicting high-speed jet noise," *AIAA J.* **49**(7), 1324 - 1335 (2011).
- <sup>148</sup> M. E. Goldstein, *Aeroacoustics*, (McGraw-Hill, New York, 1976).
- <sup>149</sup> M. E. Goldstein and B. M. Rosenbaum, "Emission of sound from axisymmetric turbulence convected by a mean flow with application to jet noise," NASA-TN-D-6939, National Aeronautics and Space Administration, Washington, DC (1972).
- <sup>150</sup> M. E. Goldstein and W. L. Howes, "New aspects of subsonic aerodynamic noise theory," NASA-TN-D-7158, National Aeronautics and Space Administration, Washington, DC (1973).
- <sup>151</sup> J. E. Bridges, A. Khavaran and C. A. Hunter, *Assessment of NASA's Aircraft Noise Prediction Capability*, edited by M. Dahl, NASA/TP-2012-215653 (2012), Chap. 8.

- <sup>152</sup> C. Kiris, J. Housman, M. Barad, C. Brehm, E. Sozar and S. Moini-Yekta, "Computational framework for launch, ascent, and vehicle aerodynamics (LAVA)," *Aerosp. Sci. and Technol.* **55**, 189 - 219 (2016).
- <sup>153</sup> J. E. Housman, G. D. Stich, C. C. Kiris and J. Bridges, "Jet noise prediction using hybrid RANS/LES with structured overset grids," in *Proceedings of the 23<sup>rd</sup> AIAA/CEAS Aeroacoustics Conference*, AIAA-2017-3213, Denver, CO (June 5-9, 2017).
- <sup>154</sup> G. D. Stich, J. A. Housman, A. S. Ghate and C. C. Kiris, "Jet noise prediction with large-eddy simulation for chevron nozzle flows," in *Proceedings of the AIAA Scitech 2021 Forum*, AIAA-2021-1185 (January 11-15 and 19-21, 2021).
- <sup>155</sup> F. E. McLean, *Supersonic Cruise Technology*, NASA SP-472, National Aeronautics and Space Administration, Washington, DC (1985).
- <sup>156</sup> NASA, *Proceedings of NASA Conference on Supersonic-Transport Feasibility Studies and Supersonic Research*, September 17-19, 1963, NASA-TM-X-905 (National Aeronautics and Space Administration, Washington, DC, 1963).
- <sup>157</sup> J. F. Brausch, "Flight velocity influence on jet noise of conical ejector, annular plug and segmented suppressor nozzles," NASA-CR-120961, National Aeronautics and Space Administration, Washington, DC (1972).
- <sup>158</sup> S. Hoffman, "Bibliography of Supersonic Cruise Research (SCR) program from 1980 to 1982," NASA-RP-1117, National Aeronautics and Space Administration, Washington, DC (1984).
- <sup>159</sup> L. E. Stitt, "Exhaust nozzles for propulsion systems with emphasis on supersonic cruise aircraft," NASA-RP-1235, National Aeronautics and Space Administration, Washington, DC (1990).

<sup>160</sup> NASA, Proceedings of the SCAR Conference, NASA-CP-001 (National Aeronautics and Space Administration, Washington, DC, 1976).

<sup>161</sup> NASA, Supersonic Cruise Research '79, NASA-CP-2108 (National Aeronautics and Space Administration, Washington, DC, 1979).

<sup>162</sup> L. H. Fishbach, L. E. Stitt, J. R. Stone and J. B. Whitlow, "NASA research in supersonic propulsion - A decade of progress," NASA-TM-82862, National Aeronautics and Space Administration, Washington, DC (1982).

<sup>163</sup> J. F. Brausch, "Flight velocity influence on jet noise of conical ejector, annular plug and semented suppressor nozzles," NASA-CR-120961, National Aeronautics and Space Administration, Washington, DC (1972).

<sup>164</sup> R. R. Burley and A. L. Johns, "Flight velocity effects on jet noise of several variations of a twelve-chute suppressor installed on a plug nozzle," NASA-TM-X-2918, National Aeronautics and Space Administration, Washington, DC (1974).

<sup>165</sup> R. R. Burley and V. L. Head, "Flight velocity effects on jet noise of several variations of a 48-tube suppressor installed on a plug nozzle," NASA-TM-X-2919, National Aeronautics and Space Administration, Washington, DC (1974).

<sup>166</sup> A. Atencio, Jr., "The effect of forward speed on J85 engine noise from suppressor nozzles as measured in the NASA-Ames 40- by 80-Foot Wind Tunnel," NASA-TN-D-8426, National Aeronautics and Space Administration, Washington, DC (1977).

<sup>167</sup> R. G. Huff and D. E. Groesbeck, "Splitting supersonic nozzle flow into separate jets by overexpansion into a multilobed divergent nozzle," NASA-TN-D-6667, National Aeronautics and Space Administration, Washington, DC (1972).

<sup>168</sup> R. G. Huff and D. E. Groesbeck, "Cold-flow acoustic evaluation of small-scale, divergent, lobed nozzle for supersonic jet noise suppression," NASA-TM-X-3210, National Aeronautics and Space Administration, Washington, DC (1975).

<sup>169</sup> J. Atvars, G. C. Paynter and D. Q. Walker, "Development of acoustically lined ejector technology for multitube jet noise suppressor nozzles by model and engine tests over a wide range of jet pressure ratios and temperatures," NASA-CR-2382, National Aeronautics and Space Administration, Washington, DC (1974).

<sup>170</sup> E. S. Johnson and R. A. McKinnon, "Cooperative wind tunnel tests of Douglas Advanced Supersonic Technology Jet Noise Suppressor - Using RR Viper 601 Engine," NASA-CR-165672, National Aeronautics and Space Administration, Washington, DC (1981).

<sup>171</sup> H. Kozlowski and A. B. Packman, "Aerodynamic and acoustic tests of duct-burning turbofan exhaust nozzles," NASA-CR-2628, National Aeronautics and Space Administration, Washington, DC (1976).

<sup>172</sup> P. R. Knott, J. F. Brausch, P. K. Bhutiani, R. K. Majjigi and V. L. Doyle, "VCE early acoustic test results of General Electric's high-radius ratio coannular plug nozzle," NASA-CP-2108, National Aeronautics and Space Administration, Washington, DC (1979).

<sup>173</sup> C. Driver, "Progress in supersonic cruise technology," in *Proceedings of the AIAA Aircraft Systems and Technology Conference*, AIAA-81-1687, Dayton, OH (August 11-13, 1981).

- <sup>174</sup> W. D. Grantham and P. M. Smith, "Development of SCAR aircraft takeoff and landing procedures for community noise abatement and their impact on flight safety," NASA-CP-2108, National Aeronautics and Space Administration, Washington, DC (1979), pp. 299-284.
- <sup>175</sup> B. R. Wright, T. A. Sedgwick and D. A. Urie, "An advanced concept that promises ecological and economic viability," NASA-CP-001 Part 2, National Aeronautics and Space Administration, Washington, DC (1976), pp. 939-984.
- <sup>176</sup> L. Maestrello, "Initial results of a porous plug nozzle for supersonic jet noise suppression," NASA-TM-78802, National Aeronautics and Space Administration, Washington, DC (1978).
- <sup>177</sup> J. M. Seiner, T. D. Norum and L. Maestrello, "Effects of nozzle design on the noise from supersonic jets," NASA-CP-2108, National Aeronautics and Space Administration, Washington, DC (1979).
- <sup>178</sup> L. Maestrello, "An experimental study of porous plug jet noise suppressor," in *Proceedings of the AIAA 5<sup>th</sup> Aeroacoustics Conference*, AIAA-79-0673, Seattle, WA (March 12-14, 1979).
- <sup>179</sup> J. Goodykoontz, "Effect of a semi-annular thermal acoustic shield on jet exhaust noise," NASA-TM-81615, National Aeronautics and Space Administration, Washington, DC (1980).
- <sup>180</sup> J. C. E. K. Morris, M. M. Winston and S. J. Morris, "Some key considerations for high-speed civil transports," in *Proceedings of the AIAA/AHS/ASEE Aircraft Design, Systems and Operations Meeting*, AIAA-88-4466, Atlanta, GA (September 7-9, 1988).
- <sup>181</sup> J. Albers and J. Zuk, "Aircraft technology opportunities for the 21st century," NASA-TM-101060, National Aeronautics and Space Administration, Washington, DC (1988).

<sup>182</sup> J. M. Seiner and E. A. Krejsa, "Supersonic jet noise and the high speed civil transport," in *Proceedings of the AIAA-89-2358*, Monterey, CA (July 10 - 12, 1989).

<sup>183</sup> Aeronautical Policy Review Committee, "National aeronautics R & D goals: Technology for America's future," Executive Office of the President, Office of Science and Technology Policy, Washington, DC (1987).

<sup>184</sup> R. E. Anderson, "First annual HSR program workshop headquarters perspective," in *Proceedings of the First Annual High-Speed Research Workshop*, NASA-CP-10087 Part I, Williamsburg, VA, (May 14 - 16, 1991) pp. 3-24.

<sup>185</sup> B. J. Blaha, "NASA HSR Phase I Low Noise Nozzle Technology Program overview," in *Proceedings of the First Annual High-Speed Research Workshop*, NASA-CP-10087 Part II, Williamsburg, VA, (May 14 - 16, 1991), pp. 507 – 516.

<sup>186</sup> Pratt & Whitney and General Electric, "Critical propulsion components Vol. 3: exhaust nozzle," NASA/CR-2005-213584/Vol3, National Aeronautics and Space Administration, Washington, DC (2005).

<sup>187</sup> V. G. Mengle and W. N. Dalton, "Lobed mixer design for noise suppression: acoustic and aerodynamic test data analysis," NASA/CR-2002-210823/Vol1, National Aeronautics and Space Administration, Washington, DC (2002).

<sup>188</sup> V. G. Mengle, V. D. Baker and W. N. Dalton, "Lobed mixer design for noise suppression: Plume, aerodynamic and acoustic data," NASA/CR-2002-210823/Vol2, National Aeronautics and Space Administration, Washington, DC (2002).

- <sup>189</sup> M. Salikuddin, A. Wisler and R. Majjigi, "Acoustic, flow related, and performance related experimental results for generation 1.5 High Speed Civil Transport (HSCT) 2-dimensional exhaust nozzles," NASA-CR-2004-213117, National Aeronautics and Space Administration, Washington, DC (2004).
- <sup>190</sup> W. H. Brown and J. F. Brausch, "GE/Boeing acoustic test axisymmetric mixer/ejector nozzle," in *Proceedings of the First NASA/Industry High Speed Research Program Nozzle Symposium*, NASA/CP-1999-209423, Paper 5, Cleveland, OH (November 17-19, 1999).
- <sup>191</sup> J. Bridges and J. Marino, "Pratt & Whitney," in *Proceedings of the First NASA/Industry High Speed Research Program Nozzle Symposium*, NASA/CP-1999-209423, Paper 7, Cleveland, OH (November 17-19, 1999).
- <sup>192</sup> G. L. Nihart, "Test results Boeing NFM nozzle in LSAF," in *Proceedings of the First NASA/Industry High Speed Research Program Nozzle Symposium*, NASA/CP-1999-209423, Paper 8, Cleveland, OH (November 17-19, 1999).
- <sup>193</sup> T. J. Barber, R. E. LaBarre and L. M. Chiappetta, "Analysis of a second generation mixer-ejector exhaust system," in *Proceedings of the First NASA/Industry High Speed Research Program Nozzle Symposium*, NASA/CP-1999-209423, Paper 17, Cleveland, OH (November 17-19, 1999).
- <sup>194</sup> K. B. M. Q. Zaman, M. F. Reeder and M. Samimy, "Control of an axisymmetric jet using vortex generators," *Physics of Fluids A* **6**(2), 778 - 793 (1994).
- <sup>195</sup> M. Salikuddin, J. Brausch and V. Mengle, "Acoustic and aero-mixing tests of fluid shield nozzles: Part 1- Acoustics," in *Proceedings of the First NASA/Industry High Speed Research Program Nozzle Symposium*, NASA/CP-1999-209423, Paper 4, Cleveland, OH (November 17-19, 1999).

<sup>196</sup> B. Strack, "The propulsion accomplishments of the NASA-Industry high speed research program," NASA/CR-2005-213332, National Aeronautics and Space Administration, Washington, DC (2005).

<sup>197</sup> T. D. Norum, R. A. Golub and W. L. Willshire, "Comparisons of shock noise predictions with flight data," in *Proceedings of the First NASA/Industry High Speed Research Program Nozzle Symposium*, NASA/CP-1999-209423, Paper 30, Cleveland, OH (November 17-19, 1999).

<sup>198</sup> T. D. Norum, D. P. Garber, R. A. Golub and O. L. S. Maria, "Supersonic jet exhaust noise at high subsonic flight speed," NASA/TP-2004-212686, National Aeronautics and Space Administration, Washington, DC (2004).

<sup>199</sup> E. J. Rice and G. Raman, "Mixing noise reduction for rectangular supersonic jets by nozzle shaping and induced screech mixing," NASA-TM-106364, National Aeronautics and Space Administration, Washington, DC (1993).

<sup>200</sup> H. H. Hubbard and J. C. Manning, "Aeroacoustic research facilities at NASA Langley Research Center," NASA TM 84585, National Aeronautics and Space Administration, Washington, DC (1983).

<sup>201</sup> M. Harper-Bourne and M. J. Fisher, "The noise from shock waves in supersonic jets," *In AGARD Conference Proceedings No. 131 – Papers, Technical Evaluation and Discussion of the Fluid Dynamics Panel Specialists' Meetings*, Brussels, Belgium (September 19-21, 1973), Paper 11-1.

<sup>202</sup> J. M. Seiner and T. D. Norum, "Experiments of shock associated noise on supersonic jets," in *Proceedings of the AIAA 12<sup>th</sup> Fluid and Plasam Dynamics Conference*, AIAA-79-1526, Williamsburg, VA (July 23-25, 1979).



- <sup>203</sup> C. K. W. Tam, "Effects of forward flight on broadband shock associated noise of supersonic jets," Lockheed-Georgia Company IR&D Project 84R465, Lockheed-Martin, Marietta, GA (1984).
- <sup>204</sup> T. D. Norum and J. M. Seiner, "Measurements of mean static pressure and far-field acoustics of shock-containing supersonic jets," NASA-TM-84521, National Aeronautics and Space Administration, Washington, DC 1(1982).
- <sup>205</sup> T. D. Norum and J. G. Shearin, "Shock structure and noise of supersonic jets in simulated flight to Mach 0.4," NASA-TP-2785, National Aeronautics and Space Administration, Washington, DC (1988).
- <sup>206</sup> T. D. Norum and J. G. Shearin, "Shock noise from supersonic jets in simulated flight to Mach 0.4," in *Proceedings of the AIAA 10<sup>th</sup> Aeroacoustics Conference, AIAA-86-1945*, Seattle, WA (July 9-11, 1986).
- <sup>207</sup> T. D. Norum and M. C. Brown, "Simulated high speed flight effects on supersonic jet noise," in *Proceedings of the 15<sup>th</sup> AIAA Aeroacoustics Conference, AIAA-93-4388*, Long Beach, CA (1993).
- <sup>208</sup> S. P. Pao and M. D. Salas, "A numerical study of two-dimensional shock vortex interaction," in *Proceedings of the AIAA 14<sup>th</sup> Fluid and Plasma Dynamics Conference, AIAA-81-1205*, Palo Alto, CA (1981).
- <sup>209</sup> S. P. Pao and J. M. Seiner, "Shock-Associated Noise in Supersonic Jets," *AIAA J.* **21**(5), 687 - 693 (1983).
- <sup>210</sup> G. Raman, "Advances in understanding supersonic jet screech: Review and perspective," *Prog. Aerosp. Sci.* **34**, 45-106 (1998).

- <sup>211</sup> J. Panda and R. G. Seasholtz, "Measurements of shock structure and shock-vortex interaction in underexpanded jets using Rayleigh scattering," *Phys. Fluids* **11**(12), 3761 - 3777 (1999).
- <sup>212</sup> K. B. M. Q. Zaman, M. D. Dahl, T. J. Bencic and C. Y. Loh, "Investigation of a 'transonic resonace' with convergent-divergent nozzles," *J. Fluid Mech.* **463**, 313 - 343 (2002).
- <sup>213</sup> J. M. Seiner, J. C. Manning and M. K. Ponton, "Dynamic pressure loads associated with twin supersonic plume resonance," *AIAA J.* **26**(8), 954 - 960 (1988).
- <sup>214</sup> J. M. Seiner, "Impact of dynamic loads on propulsion integration," in *Proceedings of the 78<sup>th</sup> AGARD-Structures and Materials Panel Meeting*, Lillehammer, Norway (May 2-6, 1994), AGARD-CP-549.
- <sup>215</sup> H. Oertel, "Mach wave radiation of hot supersonic jets investigated by means of the shock tube and new optical techniques," in *Shock Tubes and Waves: Proceedings of the 12th International Symposium on Shock Tubes and Waves*, Jerusalem, Israel, (July 16-19, 1980), pp. 266 - 275.
- <sup>216</sup> J. M. Seiner, D. K. McLaughlin and C. H. Liu, "Supersonic jet noise generated by large-scale instabilities," NASA TP-2072, National Aeronautics and Space Administration, Washington, DC (1982).
- <sup>217</sup> P. J. Morris and C. K. W. Tam, "Near- and far-field noise from large-scale instabilities of axisymmetric jets," in *Proceedings of the AIAA 4<sup>th</sup> Aeroacoustics Conference*, AIAA-77-1351, Atlanta, GA (October 3-5, 1977).
- <sup>218</sup> J. M. Seiner, "Advances in high speed jet aeroacoustics," in *Proceedings of the AIAA/NASA 9<sup>th</sup> Aeroacoustics Conference*, AIAA-84-2275, Williamsburg, VA (October 15-17, 1984).

- <sup>219</sup> J. M. Seiner and M. K. Ponton, "The effects of temperature on supersonic jet noise emission," in *Proceedings of the DGLR/ALAA 14<sup>th</sup> Aeroacoustics Conference*, DGLR/AIAA 92-02-046, Aachen, Germany (May 11-14, 1992).
- <sup>220</sup> C. K. W. Tam and F. Q. Hu, "On the three families of instability waves of high speed jets," *J. Fluid Mech.* **201**, 447 - 483 (1989).
- <sup>221</sup> J. M. Seiner, T. R. S. Bhat and M. K. Ponton, "Mach wave emission from a high-temperature supersonic jet," *AIAA J.* **32**(12), 2345 - 2350 (1994).
- <sup>222</sup> M. D. Dahl and P. J. Morris, "Noise from supersonic coaxial jets, Part 3: Inverted velocity profile," *J. Sound and Vib.* **200**(5), 701 - 719 (1997).
- <sup>223</sup> B. Henderson, J. Bridges and M. Wernet, "Jet noise reduction potential from emerging variable cycle technologies," in *Proceedings of the 48<sup>th</sup> AIAA/ASME/SAE/ASEE Joint Propulsion Conference & Exhibit*, AIAA-2012-3752, Atlanta, GA (July 30 – August 1, 2012).
- <sup>224</sup> J. Bridges, "Aeroacoustic validation of installed low noise propulsion for NASA's N+2 supersonic airliner," in *Proceedings of the 2018 AIAA Aerospace Sciences Meeting*, AIAA-2018-0009, Kissimmee, FL (January 8 – 12, 2018).
- <sup>225</sup> R. Bozak and B. Henderson, "Aeroacoustic experiments with twin jets," in *Proceedings of the 17<sup>th</sup> AIAA/CEAS Aeroacoustics Conference*, AIAA-2011-2790, Portland, OR (June 5-8, 2011).
- <sup>226</sup> D. L. Huff, B. S. Henderson, J. J. Berton and J. A. Seidel, "Perceived noise analysis for offset jets applied to commercial supersonic aircraft," in *Proceedings of the 54<sup>th</sup> AIAA Aerospace Sciences Meeting*, AIAA-2016-1635, San Diego, CA (January 4-8, 2016).

<sup>227</sup> B. Henderson and D. Huff, "The aeroacoustics of offset three-stream jets for future commercial supersonic aircraft," in *Proceedings fo the 22<sup>nd</sup> ALAA/CEAS Aeroacoustics Conference*, AIAA-2016--2992, Lyon, France (May 30 – June 1, 2016).

<sup>228</sup> C. A. Brown, "Jet-surface interaction test: Far-field noise results," *J. Eng. for Gas Turbines and Power* **135**(7), 071201 - 071201-7 (2013).

<sup>229</sup> C. Brown, "An emprical jet-surface interaction noise model with temperature and nozzle aspect ratio effects," in *Proceedings of the 53<sup>rd</sup> ALAA Aerospace Sciences Meeting*, AIAA-2015-0229, Kissimmee, FL (January 5-9, 2015).

<sup>230</sup> J. Bridges, "Acoustic measurements of rectangular nozzles with bevel," in *Proceedings of the 18<sup>th</sup> ALAA/CEAS Aeroacoustics Conference*, AIAA-2012-2552, Colorado Springs, CO (June 4-6, 2012).

<sup>231</sup> J. Bridges, "Noise from aft deck exhaust nozzles - differences in experimental embodiments," in *Proceedings of the 53<sup>rd</sup> Aerospace Sciences Meeting*, AIAA-2014-0876, National Harbor, MD (January 13-17, 2014).

<sup>232</sup> B. Henderson and J. Bridges, "An MDOE investigation of chevrons for supersonic jet noise reduction," in *Proceedings of the 16<sup>th</sup> ALAA/CEAS Aeroacoustics Conference*, AIAA-2010-3926 (June 7-9, 2010).

<sup>233</sup> B. Henderson and M. Wernet, "An experimental investigation of overexpanded jets with chevrons," *J. Sound and Vib.* **351**, 119 - 142 (2015).

<sup>234</sup> J. Panda, R. G. Seasholtz and K. A. Elam, "Investigation of noise sources in high-speed jets via correlation measurements," *J. Fluid Mech.* **537**, 349 - 385 (2005).

<sup>235</sup> J. Panda, "Experimental investigation of turbulent density fluctuations and noise generation from heated jets," *J. Fluid Mech.* **591**, 73 - 96 (2007).

<sup>236</sup> B. S. Henderson, D. L. Huff and J. J. Berton, "Jet noise prediction comparisons with scale model tests and learjet flyover data," in *Proceedings of the 25<sup>th</sup> AIAA/CEAS Aeroacoustics Conference*, AIAA-2019-2768, Delft, The Netherlands (2019).

<sup>237</sup> J. J. Berton, D. L. Huff, J. A. Seidel and K. A. Geiselhart, "Supersonic technology concept aeroplanes for environmental studies," in *Proceedings of the AIAA-2020-0263*, AIAA-2020-0263, Orlando, FL (January 6 - 10, 2020).

<sup>238</sup> J. Berton, S. Jones, J. Seidel and D. Huff, "Noise predictions for a supersonic business jet using advanced take-off procedures," *Aeronaut. J.* **122** [1250], 556-571 (2018).

<sup>240</sup> Federal Aviation Administration, "Noise Certification of Supersonic Airplanes," FAA-2020-0316, Notice No. 20-06, Department of Transportation, Washington, DC (2020).