

Materials Informatics at NASA GRC

Joshua Stuckner

CWRU

Sept. 7, 2021

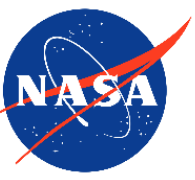

Material Informatics

It takes 20 years to go from material discovery to commercial use ^{1,2}

Materials Genome Initiative – is a federal initiative for discovering, manufacturing, and deploying advanced materials **twice as fast and at a fraction of the cost** compared to traditional methods. Announced by Obama in 2011. Thanks Obama!

Material Informatics – application of informatics (statistics, data science, machine learning, AI, etc.) to **materials science and engineering** to improve the understanding, development, and discovery of materials.

¹ Faster: Accelerating the transition from materials discovery to commercial deployment. Alexander H. King. <https://www.osti.gov/pages/servlets/purl/1556925>

² T.W. Eagar, Technology Review, 98, 43 (1995)

Predictive Models

Shape Memory Alloys

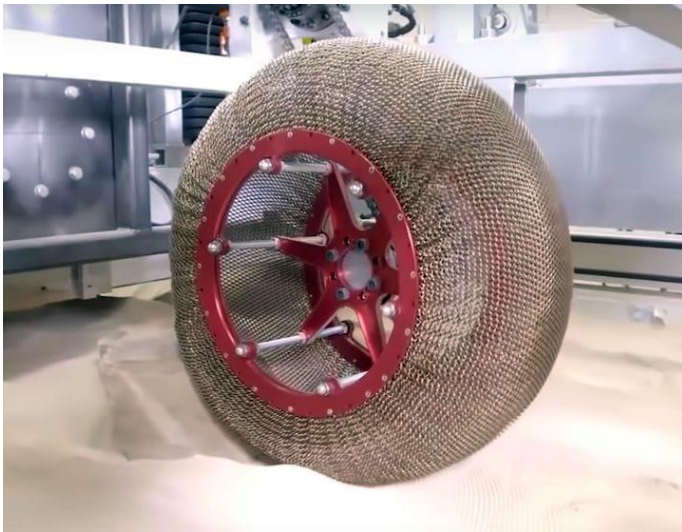

- Continuous features
 - Ni %
 - Ti %
 - Element 3 %
 - Element 4 %
 - Heat treat 1 time
 - Heat treat 1 temp
 - Heat treat 2 time
 - Heat treat 2 temp
 - Heat treat 3 time
 - Heat treat 3 temp
 - Lower Cycle Temperature
 - Higher Cycle Temperature
 - Austenite Start temp
 - Austenite finish temp
 - Martensite start temp
 - Martensite finish temp

- Categorical features
 - Element 3
 - Element 4
 - Test type
 - Processing method

Martensite Finish Temperature

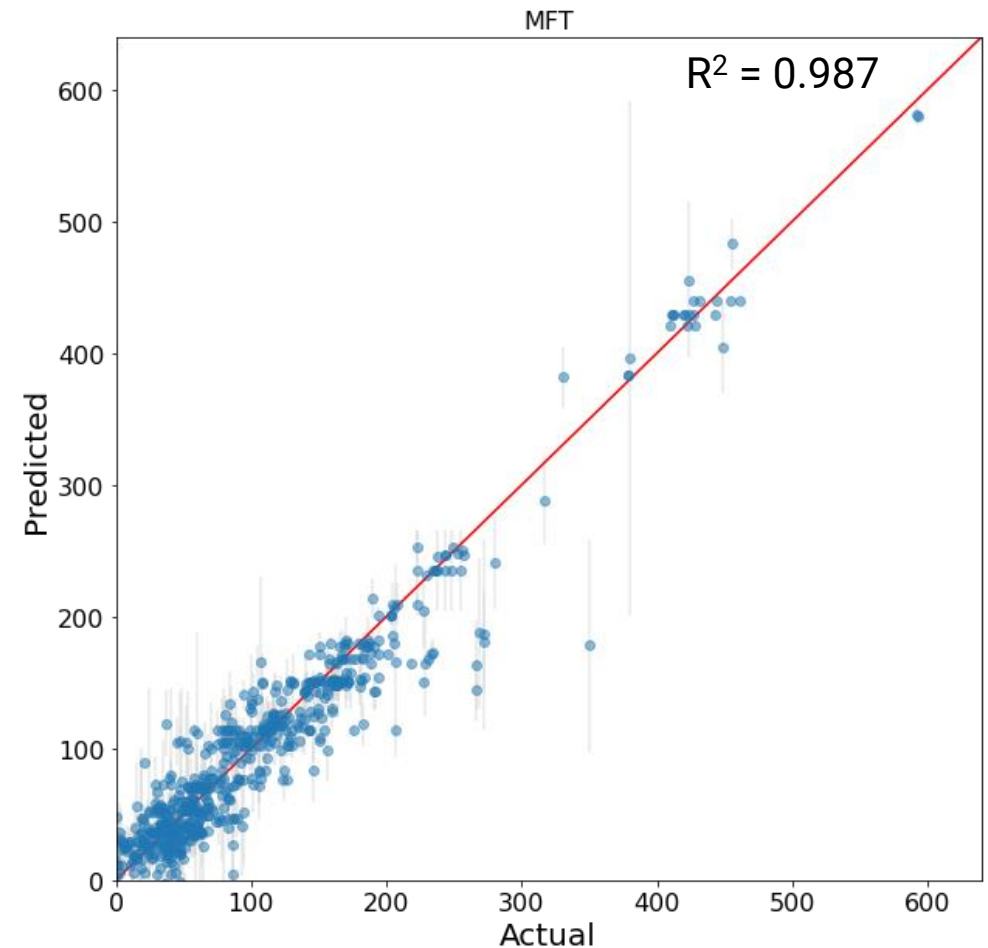

Sequential Learning

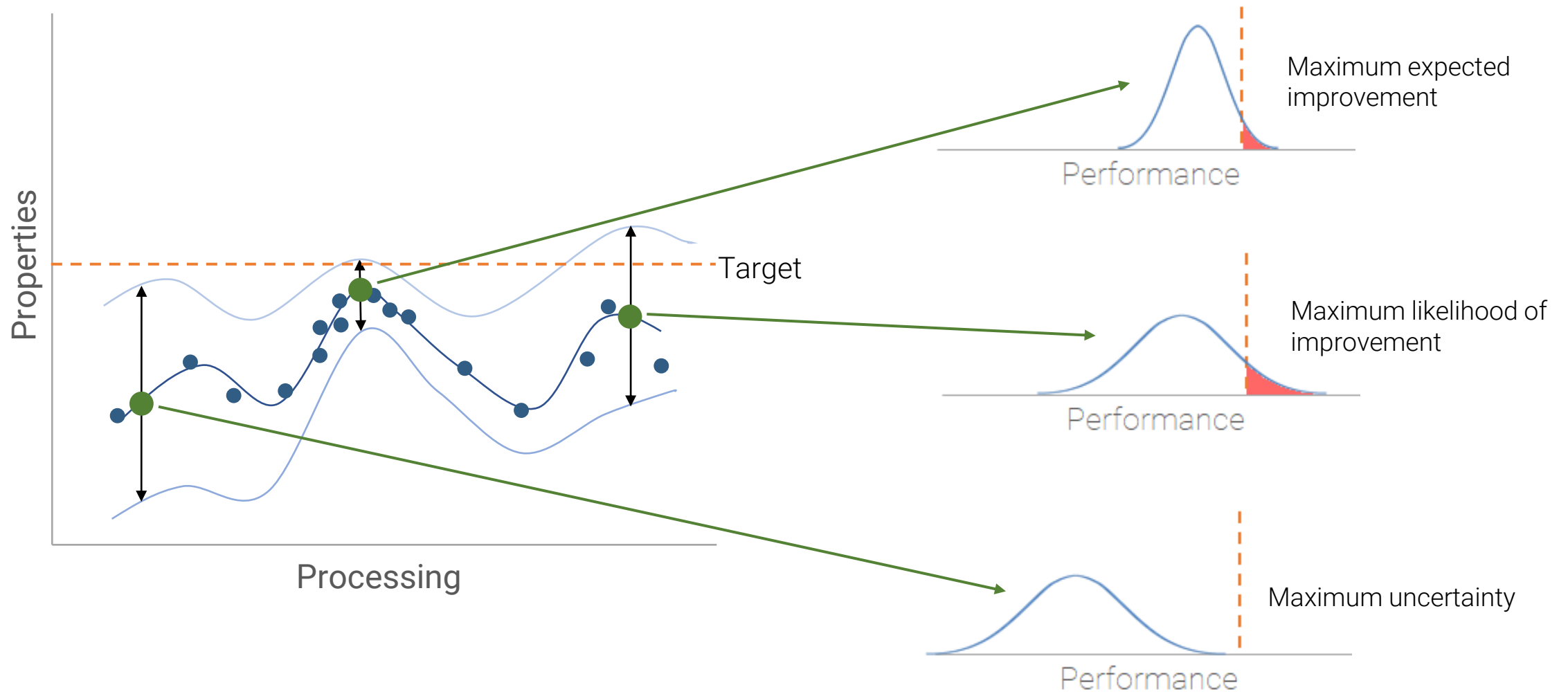

Inverse Design Workflow

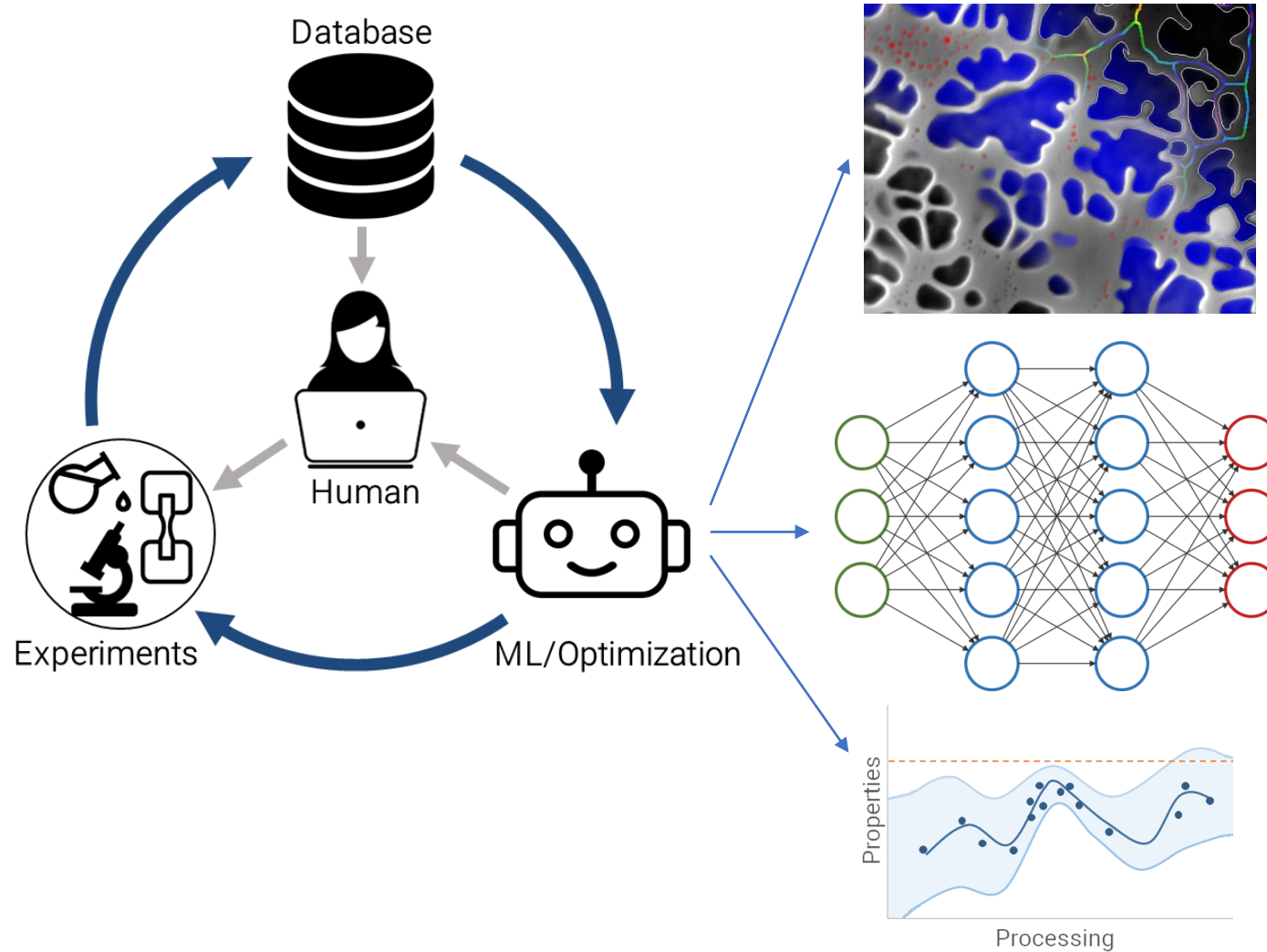

- Extract microstructure properties
- Use to build PSP models
- Web application
- SOA segmentation

- ML algorithms
- Property prediction
- PSP Relationships
- Optimization
- Simulations
- Outlier flagging
- UQ

- Suggested Experiments
- Visualization
- Predictions
- Results
- Sequential learning
- Accelerated discovery

Automatic Microstructure Analysis

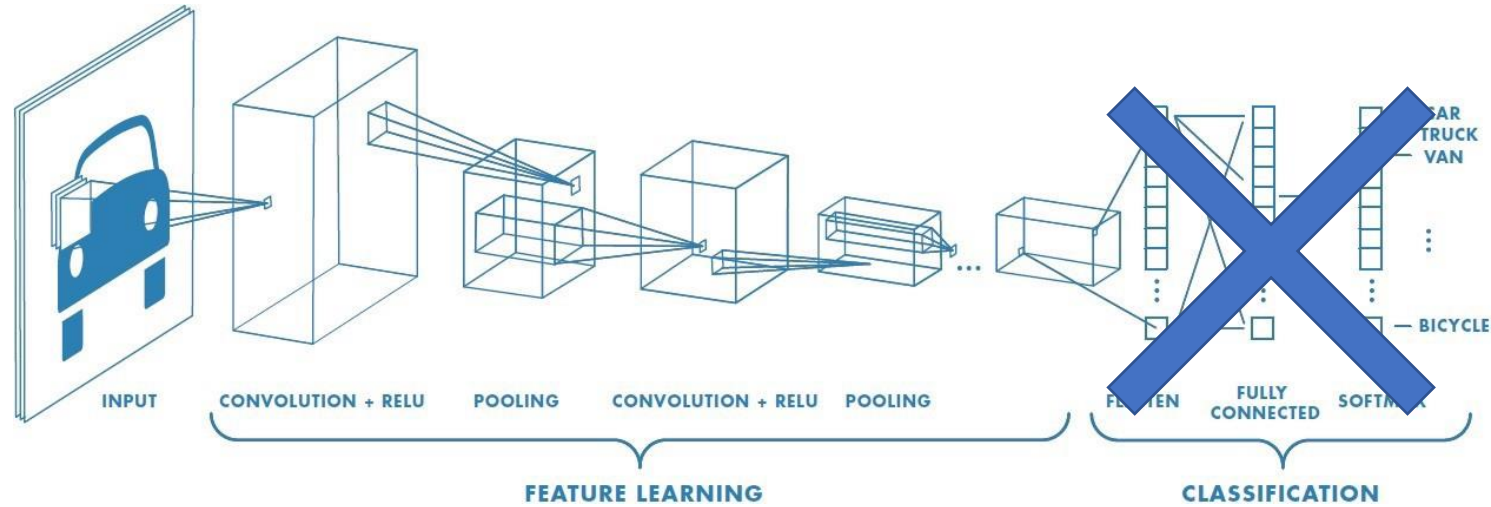

Automatic Microstructure Analysis

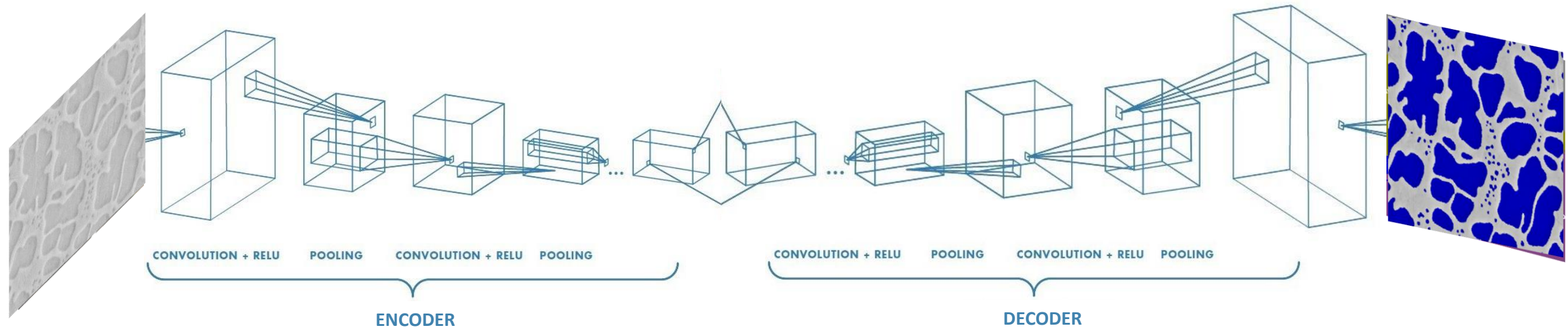

Automatic Microstructure Analysis

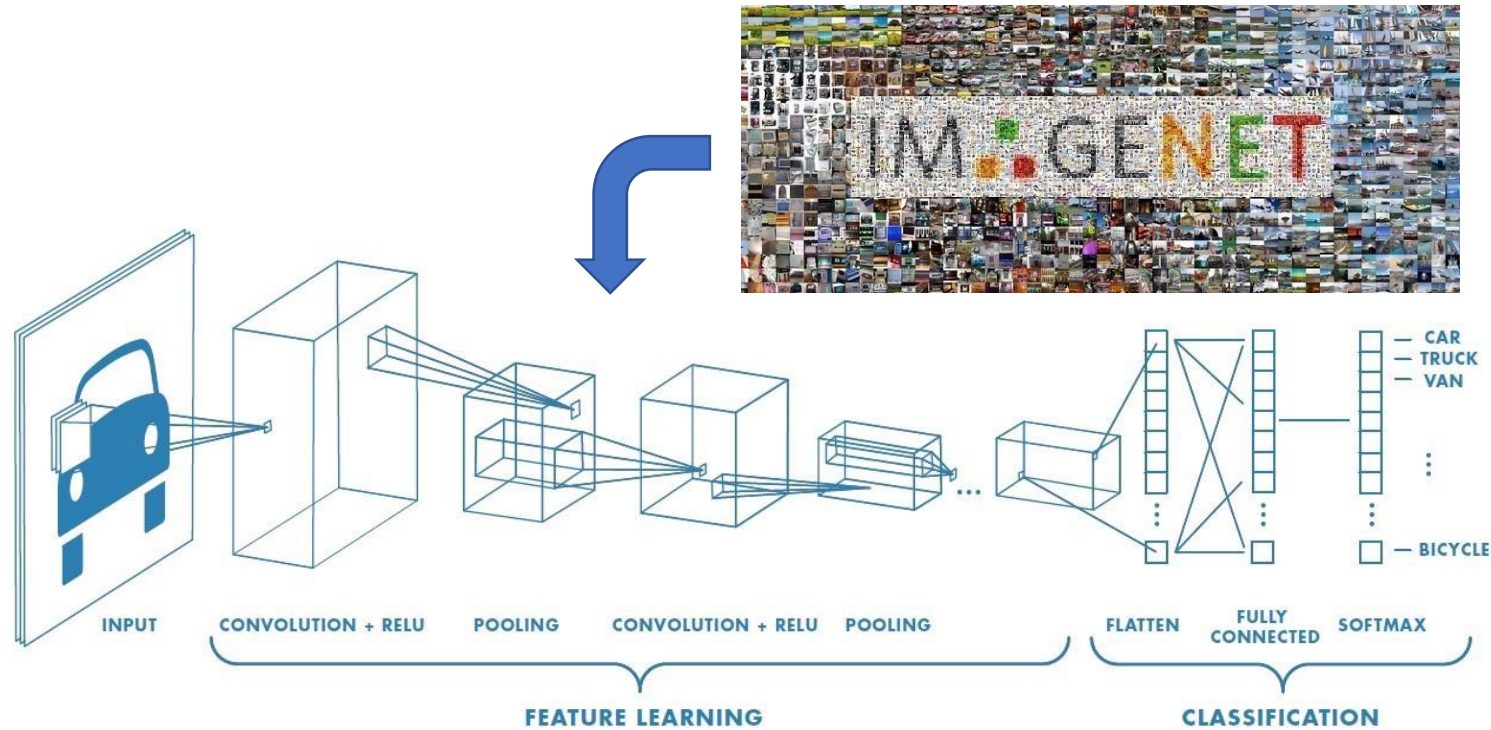

Automatic Microstructure Analysis

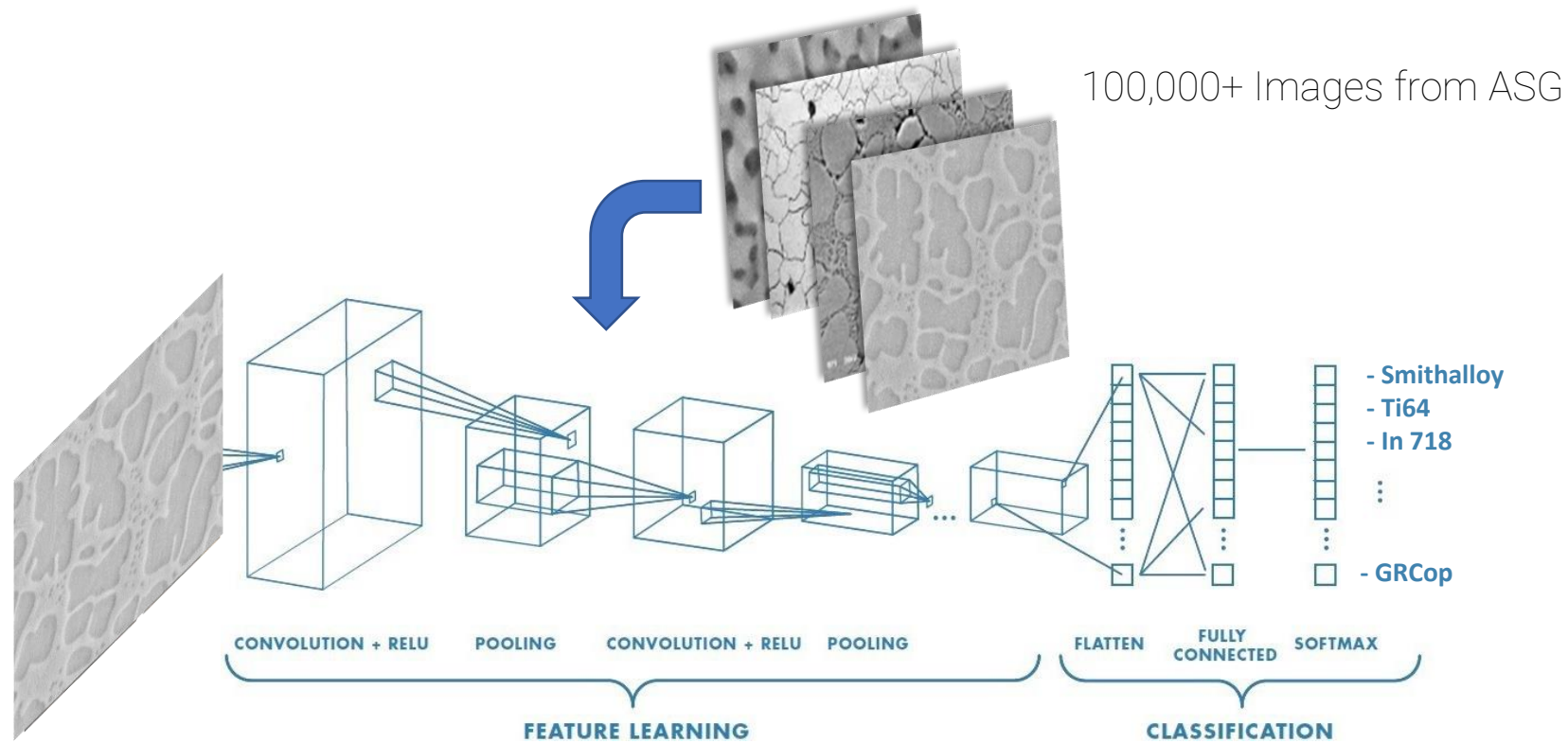

Automatic Microstructure Analysis

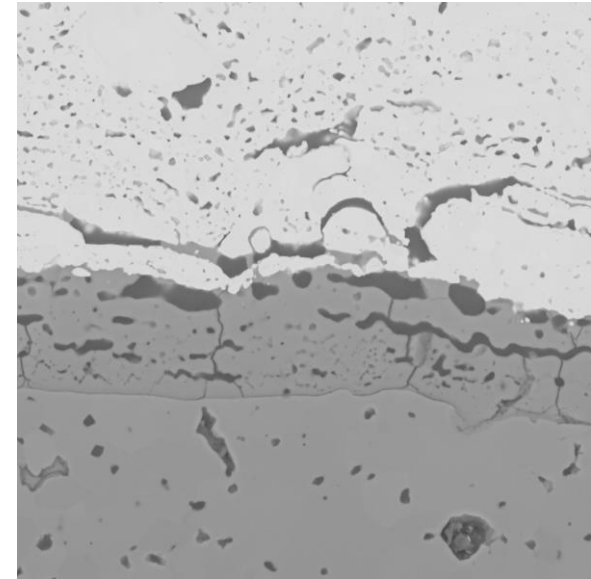
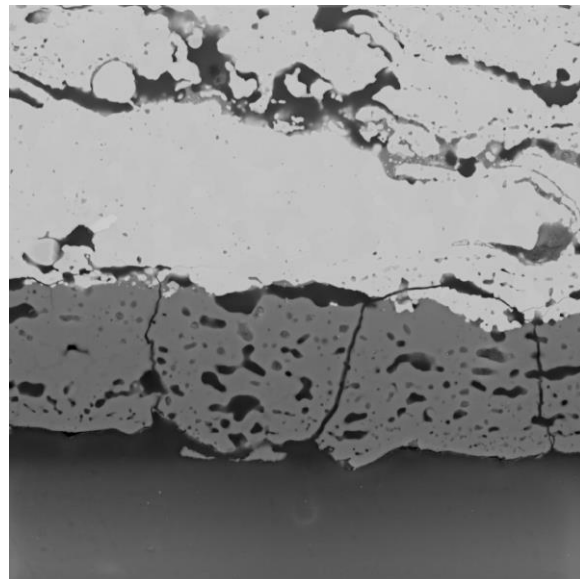
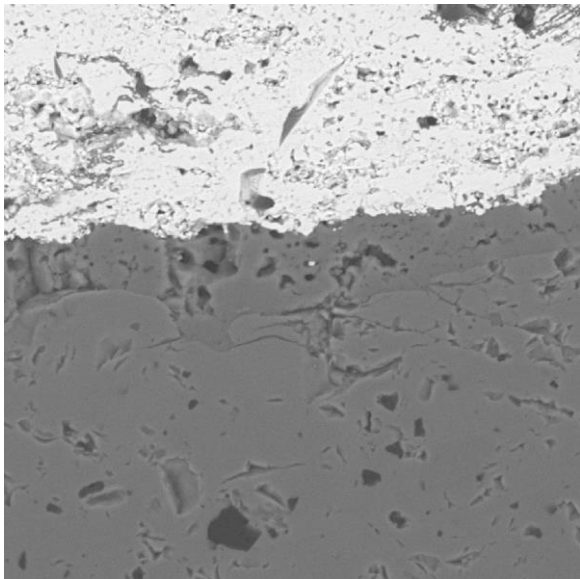
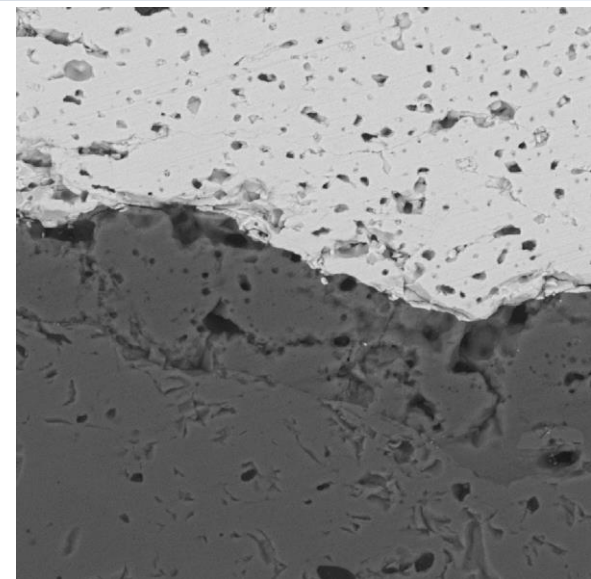
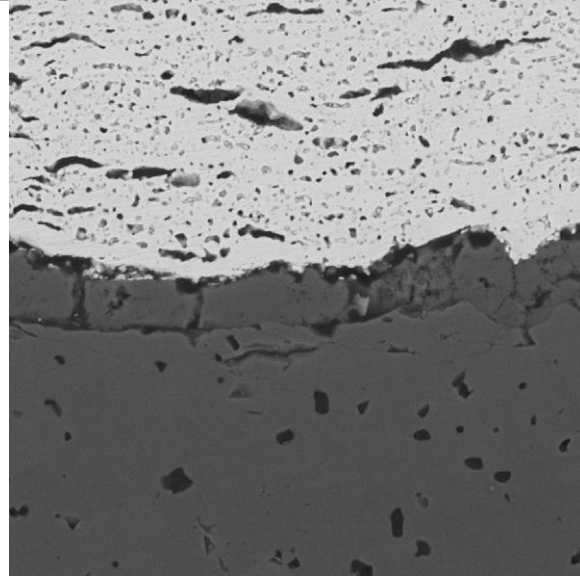
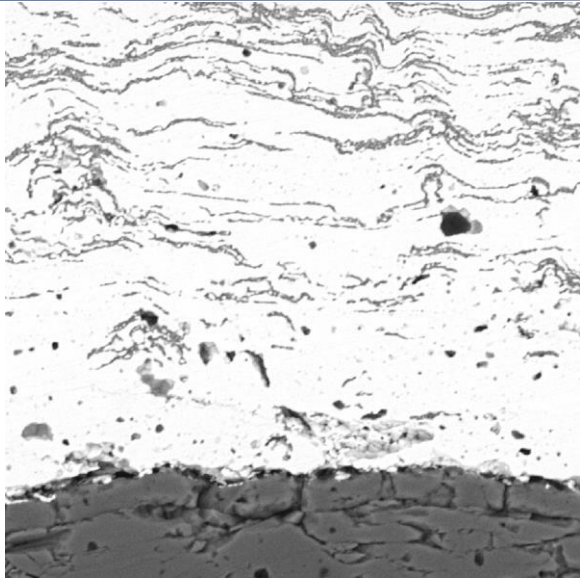

Automatic Microstructure Analysis

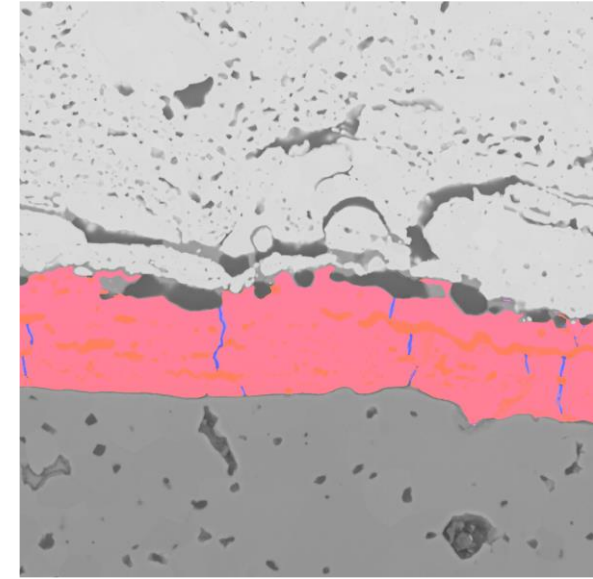
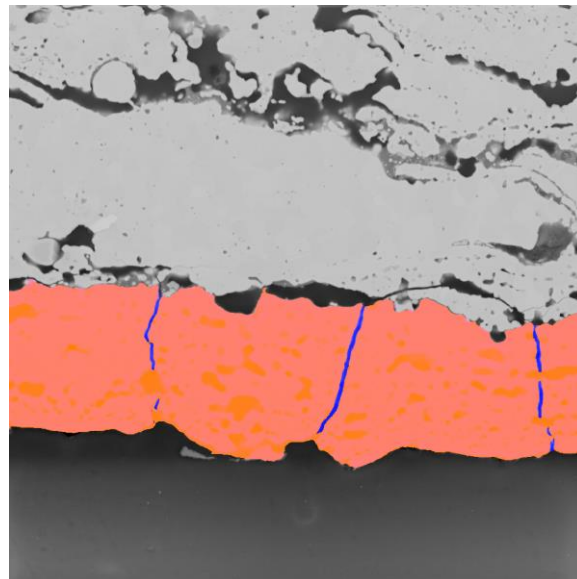
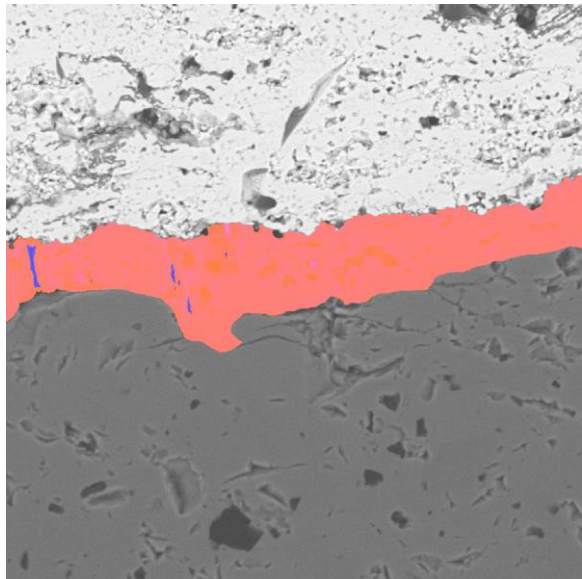
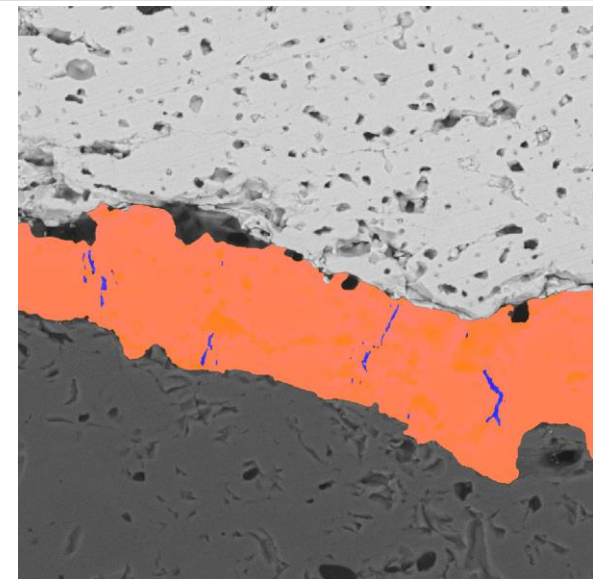
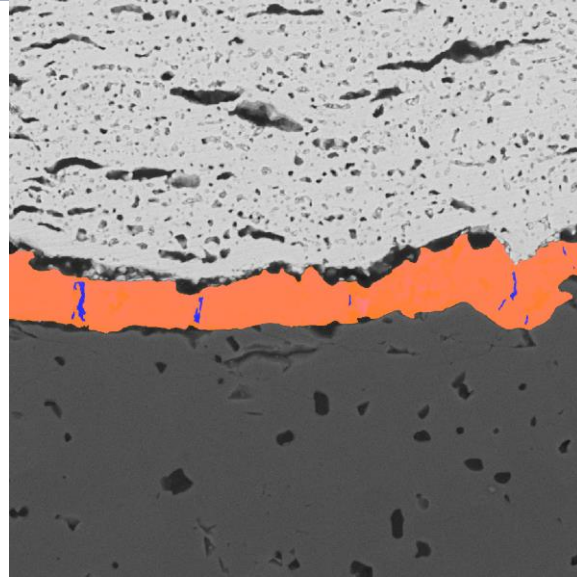
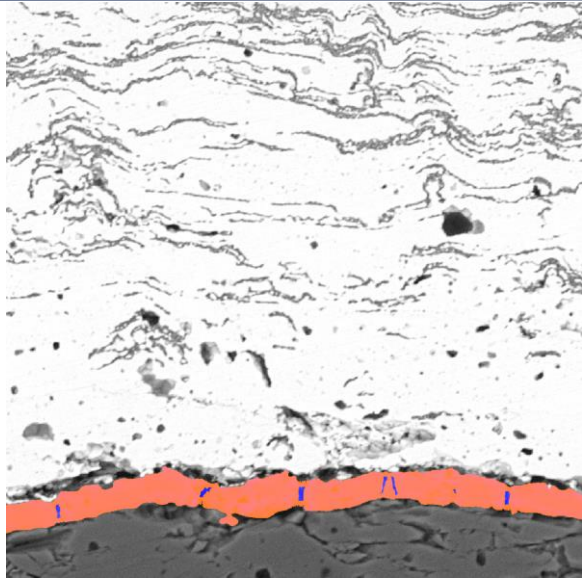

Automatic Microstructure Analysis

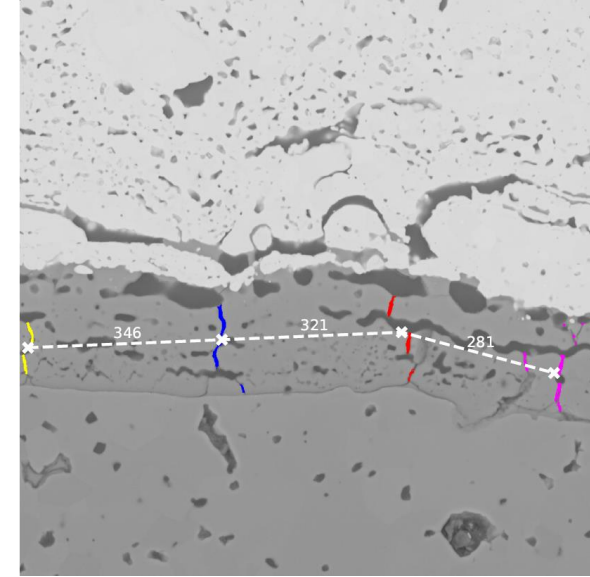
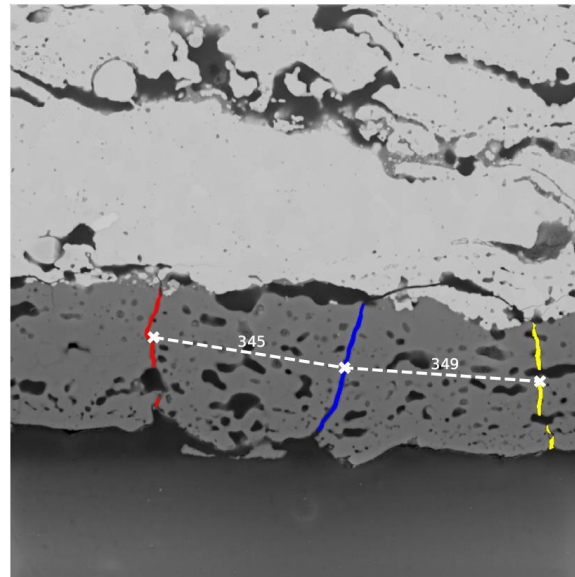
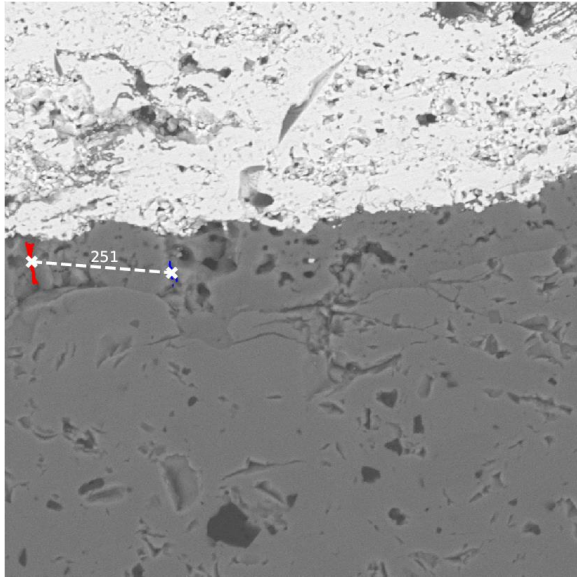
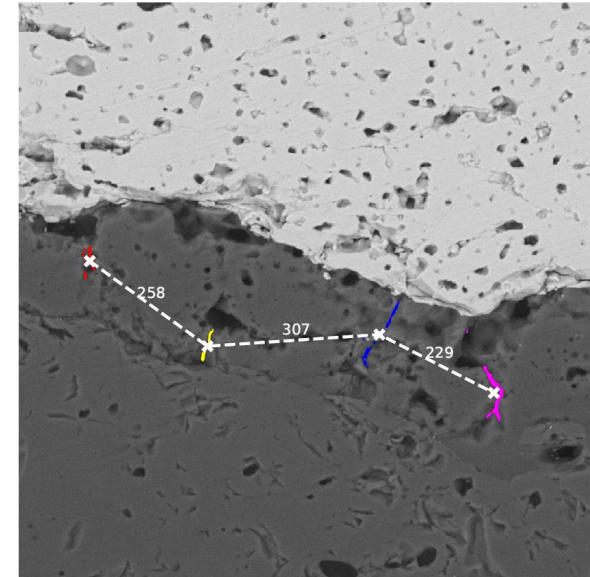
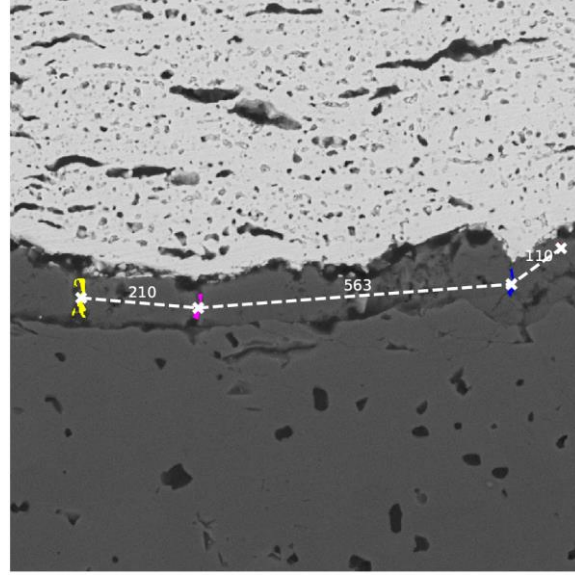
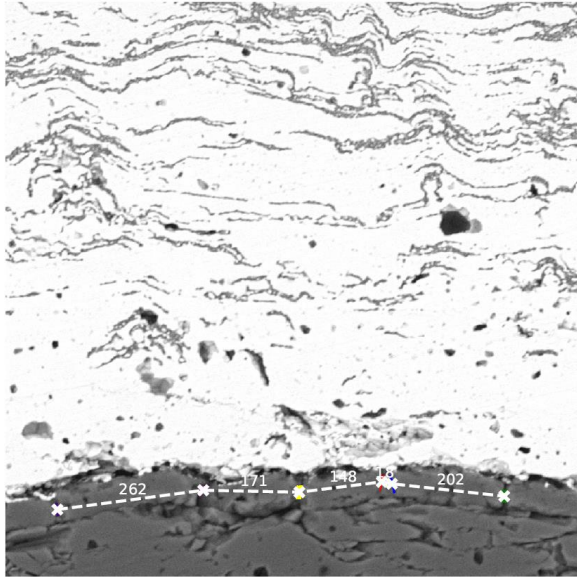

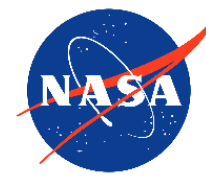

Automatic Microstructure Analysis

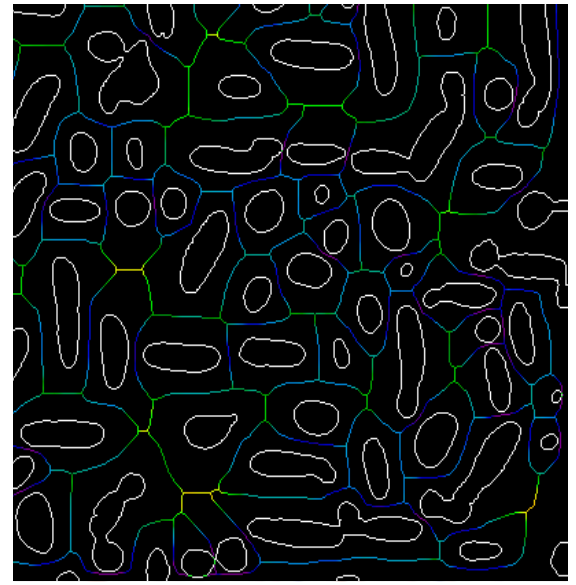
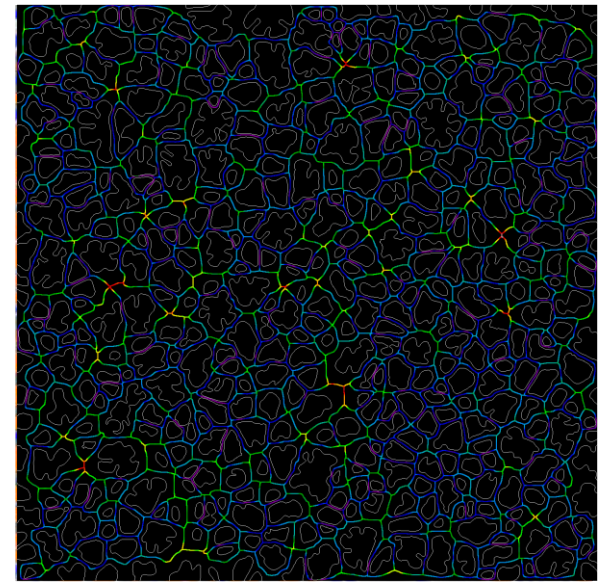
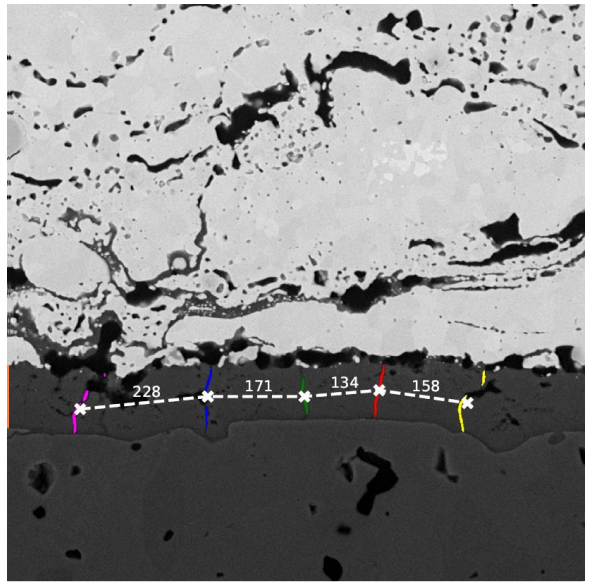

A	B	C	D	E	F	G	H	I	J	K	L	M	N	O	
0	IGRCcp-1	1	601	1289	600	1287	605	1292	15	12.48528	8.844241	4.0442	-0.32175	0.55842	
3	1	IGRCcp-1	2	603	1635	600	1629	609	1643	107	37.31371	14.72872	9.402293	1.496881	0.789606
4	2	IGRCcp-1	3	623	1530	600	1504	650	1934	983	131.9828	56.36849	23.70201	6.26788	0.899689
5	3	IGRCcp-1	4	605	1984	600	1973	635	1998	266	68.42031	23.36217	15.45205	-1.54182	0.742385
6	4	IGRCcp-1	5	791	2222	600	2095	1007	2399	25384	2140.807	555.1083	120.2401	0.462952	0.978259
7	5	IGRCcp-1	6	600	2341	600	2339	602	2345	11	11.20711	6.410748	1.96494	-1.51741	0.951888
8	6	IGRCcp-1	7	607	2933	600	2922	635	2950	302	76.29427	29.51659	14.45479	1.20884	0.871881
9	7	IGRCcp-1	8	671	3003	600	2974	755	3029	5144	451.8478	155.4692	45.61201	-0.03779	0.959595
10	8	IGRCcp-1	9	601	1097	601	1096	603	1099	4	4.62132	2.828427	1.72051	1.570796	0.790569
11	9	IGRCcp-1	10	602	2329	601	2327	604	2332	5	5.414214	6.107531	1.047887	1.178997	0.985171
12	10	IGRCcp-1	11	606	2486	602	2478	633	2495	93	45.24874	16.90973	8.328791	1.245792	0.872462
13	11	IGRCcp-1	12	806	3340	604	3251	1026	3449	30725	1893.257	465.7336	157.8169	0.17195	0.940838
14	12	IGRCcp-1	13	608	1325	606	1324	611	1328	18	12.82843	5.288738	4.268749	0	0.584013
15	13	IGRCcp-1	14	614	3104	606	3098	622	3114	160	49.45584	18.69312	11.48651	0.030239	0.799883
16	14	IGRCcp-1	15	612	2382	609	2376	617	2390	52	33.55635	15.66732	4.693847	1.14874	0.954687
17	15	IGRCcp-1	16	614	2782	609	2777	620	2789	92	33.79899	12.18298	9.732257	-1.10121	0.601543
18	16	IGRCcp-1	17	611	3137	610	3136	614	3139	8	7.658854	3.464102	2.828427	0	0.57735
19	17	IGRCcp-1	18	615	1742	613	1741	618	1746	19	13.65685	5.127073	4.712757	-0.10933	0.944686
20	18	IGRCcp-1	19	651	3517	613	3860	678	3973	2050	346.4691	128.6058	35.77718	1.16994	0.960525
21	19	IGRCcp-1	20	614	1429	614	1429	617	1432	6	6.242641	3.126944	2.309401	-0.7834	0.6742
22	20	IGRCcp-1	21	622	1254	615	1227	631	1244	213	51.45584	17.31984	15.6594	-1.11228	0.423054
23	21	IGRCcp-1	22	618	2752	615	2746	622	2758	64	28.72792	11.83033	8.878698	-1.31316	0.834064
24	22	IGRCcp-1	23	618	3214	618	3214	620	3216	2	0.2828427	0	-0.7834	1	
25	23	IGRCcp-1	24	622	4328	618	4321	630	4335	66	41.2132	16.84038	10.06601	-1.20992	0.801875
26	24	IGRCcp-1	25	621	2263	619	2261	625	2266	23	15.07184	5.026478	0.201184	0.501796	
27	25	IGRCcp-1	26	621	1473	620	1473	625	1476	18	13.65685	5.276229	4.361835	-0.13546	0.562649
28	26	IGRCcp-1	27	627	3524	626	3523	630	3528	11	11.24264	5.09304	3.285525	1.15988	0.764997
29	27	IGRCcp-1	28	632	3032	628	3029	637	3037	59	25.89949	9.380872	8.024764	0.314584	0.517604
30	28	IGRCcp-1	29	629	3083	629	3083	630	3085	2	0	0	2	0	1.570796
31	29	IGRCcp-1	30	636	3043	633	3040	641	3048	53	24.48528	8.80557	8.071253	-0.7235	0.268785
32	30	IGRCcp-1	31	637	2393	634	2389	642	2398	57	25.31371	9.853777	7.491182	-1.12026	0.830497
33	31	IGRCcp-1	32	639	1300	637	1296	643	1304	26	16.48238	5.89992	5.600679	-1.25547	0.314446
34	32	IGRCcp-1	33	639	1372	638	1372	641	1375	8	7.414214	4.464102	3.788113	-0.7834	0.612372
35	33	IGRCcp-1	34	640	3193	639	3191	643	3196	9	8.414214	6.253888	1.856163	-0.7834	0.953463
36	34	IGRCcp-1	35	645	1867	643	1863	648	1872	39	21.05685	9.477689	5.236468	1.491602	0.833817
37	35	IGRCcp-1	36	641	4845	643	4845	645	4847	4	4	2	0	0.763998	0
38	36	IGRCcp-1	37	657	2724	644	2666	1074	2800	26892	1857.653	457.7142	112.5925	-0.04046	0.969273
39	37	IGRCcp-1	38	647	1016	646	1015	649	1019	10	8.828427	4.38178	2.683282	-1.10735	0.790569
40	38	IGRCcp-1	39	673	4246	646	4221	699	4270	1157	169.111	65.10788	25.27602	-0.88376	0.921567
41	39	IGRCcp-1	40	649	3993	647	3993	652	3995	19	8.828427	5.444425	2.252495	-0.08832	0.910318
42	40	IGRCcp-1	41	649	2062	648	2060	652	2065	14	11.65685	4.955941	3.961881	0.847576	0.476347
43	41	IGRCcp-1	42	651	4008	649	4004	658	4014	64	28.14214	9.57109	8.537354	-1.30442	0.452047
44	42	IGRCcp-1	43	651	1509	651	1508	654	1511	7	6.828427	3.023716	2.799417	1.570796	0.377964
45	43	IGRCcp-1	44	651	1932	651	1932	652	1934	2	0	2	0	1.570796	0
46	44	IGRCcp-1	45	655	2286	651	2282	660	2292	65	28.14214	9.34746	8.82033	1.372432	0.321237
47	45	IGRCcp-1	46	705	1113	652	1070	785	1141	4269	512.4163	126.7348	62.60873	0.795259	0.869604
48	46	IGRCcp-1	47	654	3093	653	3092	656	3096	11	9.414214	4.346113	3.067506	-1.30776	0.708444
49	47	IGRCcp-1	48	667	3764	653	3676	1540	3888	4449	1071.191	311.947	167.6744	0.08887	0.844456

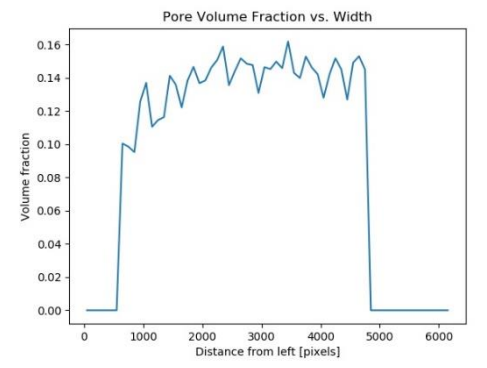
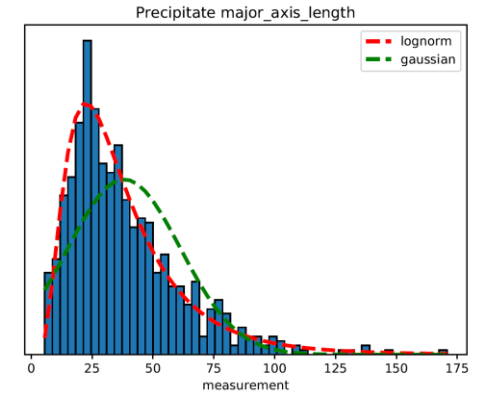
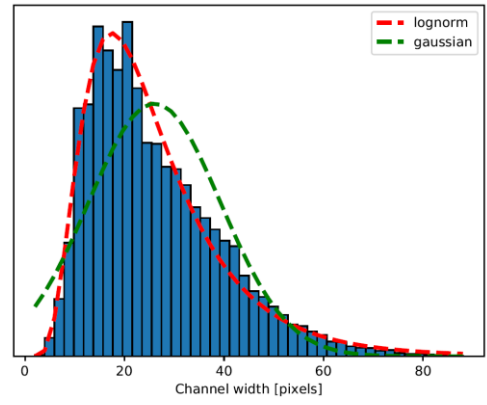
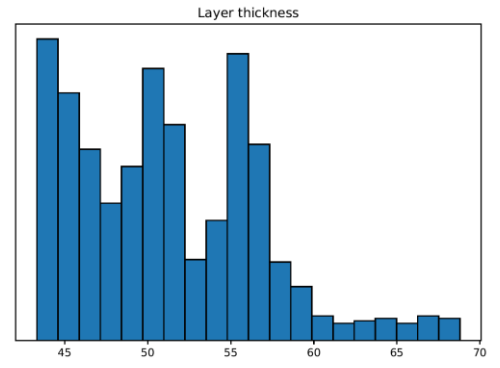

Surrogate Modeling

Modeling reduces the need for **expensive physical experiments**

Machine Learning reduces the need for **expensive modeling**

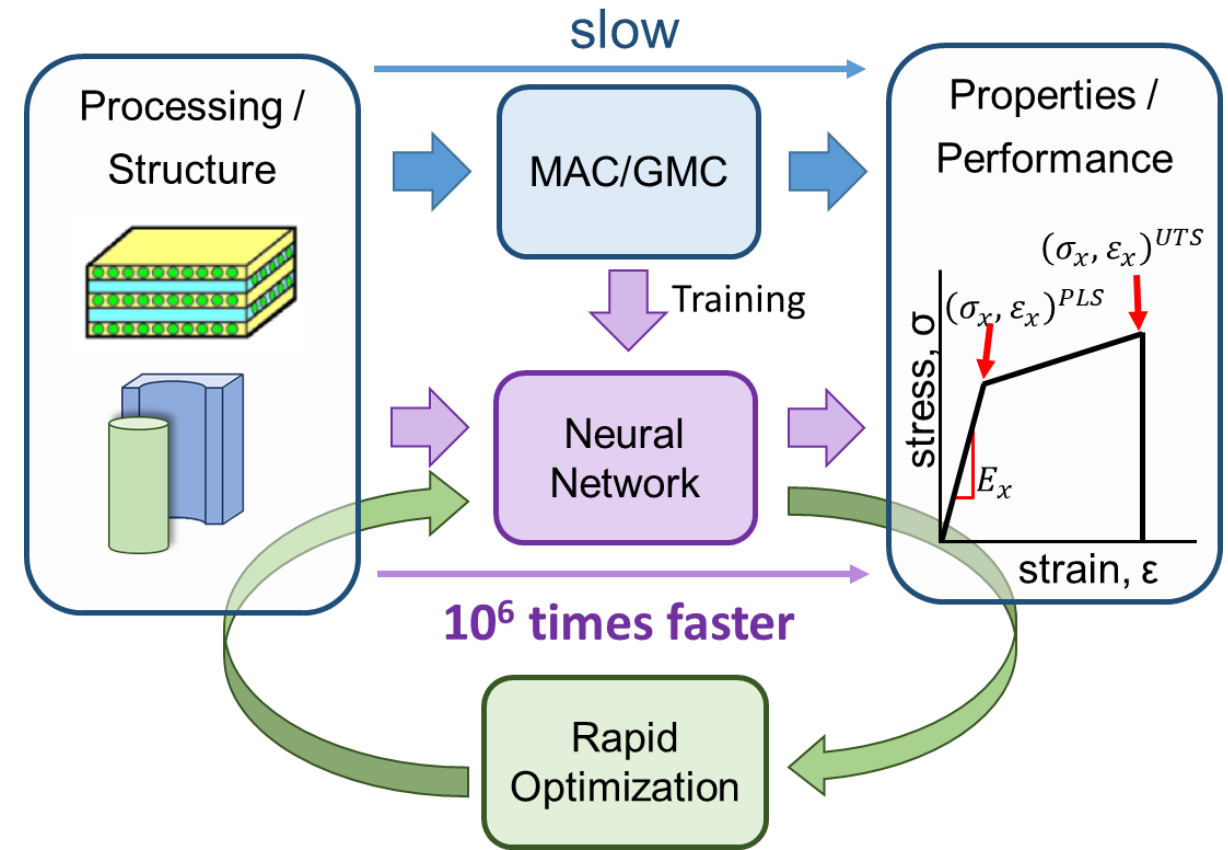

Surrogate Modeling

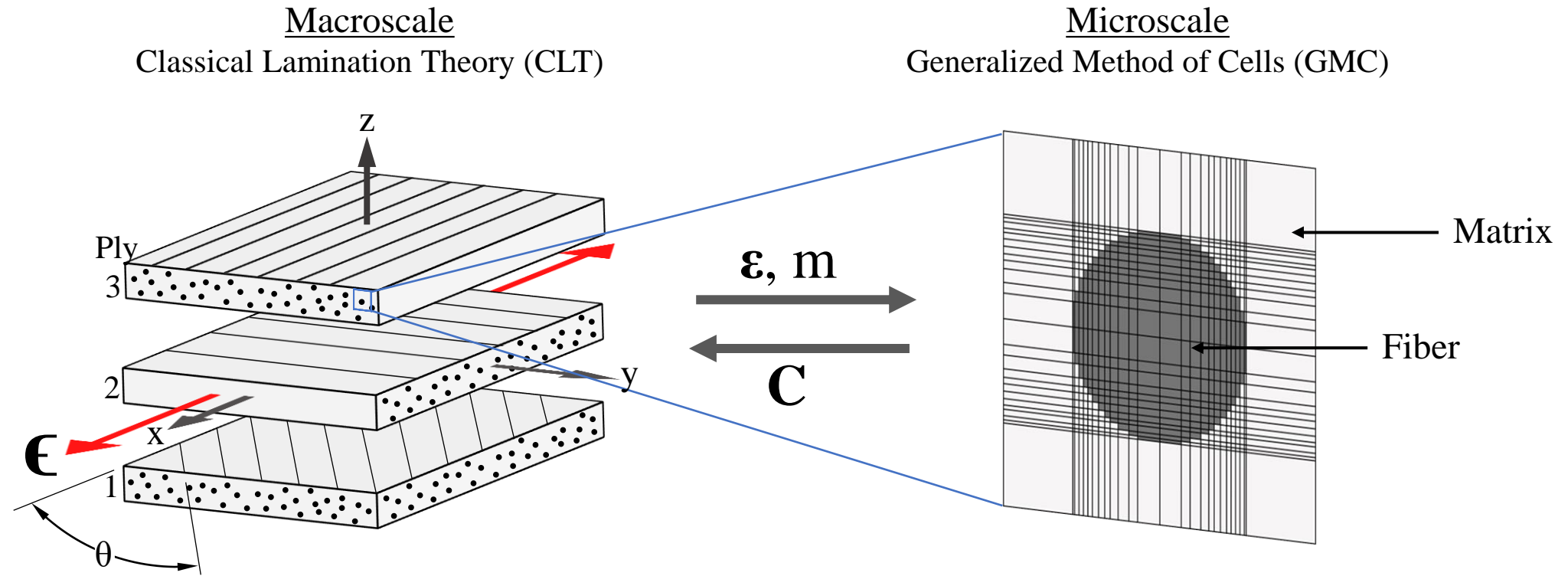

Inputs: strain increment (ϵ),
homogenized stiffness (C)

Outputs: global stress,
local strain (ϵ)

Inputs: local strain (ϵ)
Material properties (m)
Damage (d_n)

Outputs: homogenized stiffness (C)
Updated damage (d_{n+1})

Surrogate Modeling

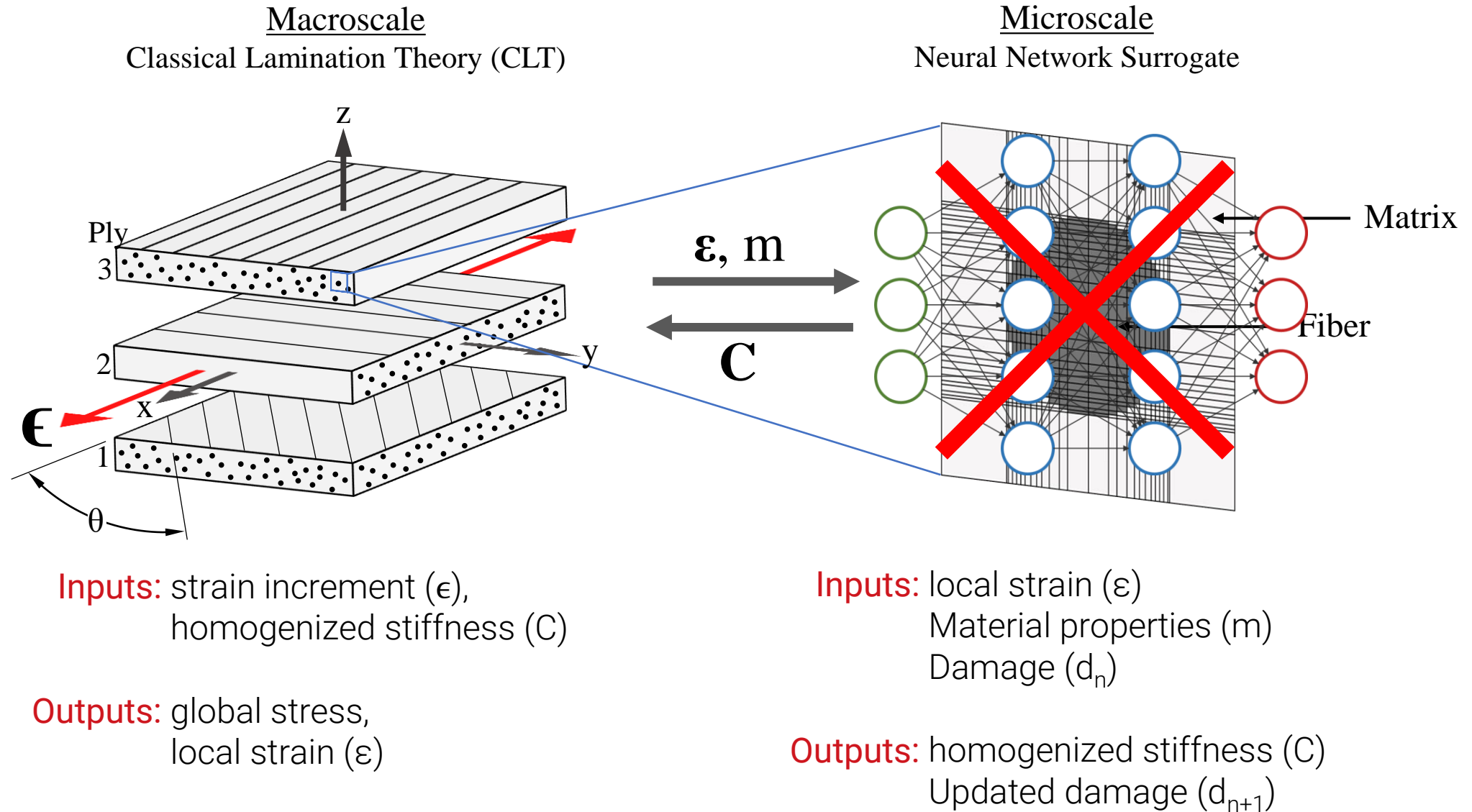

Surrogate Modeling

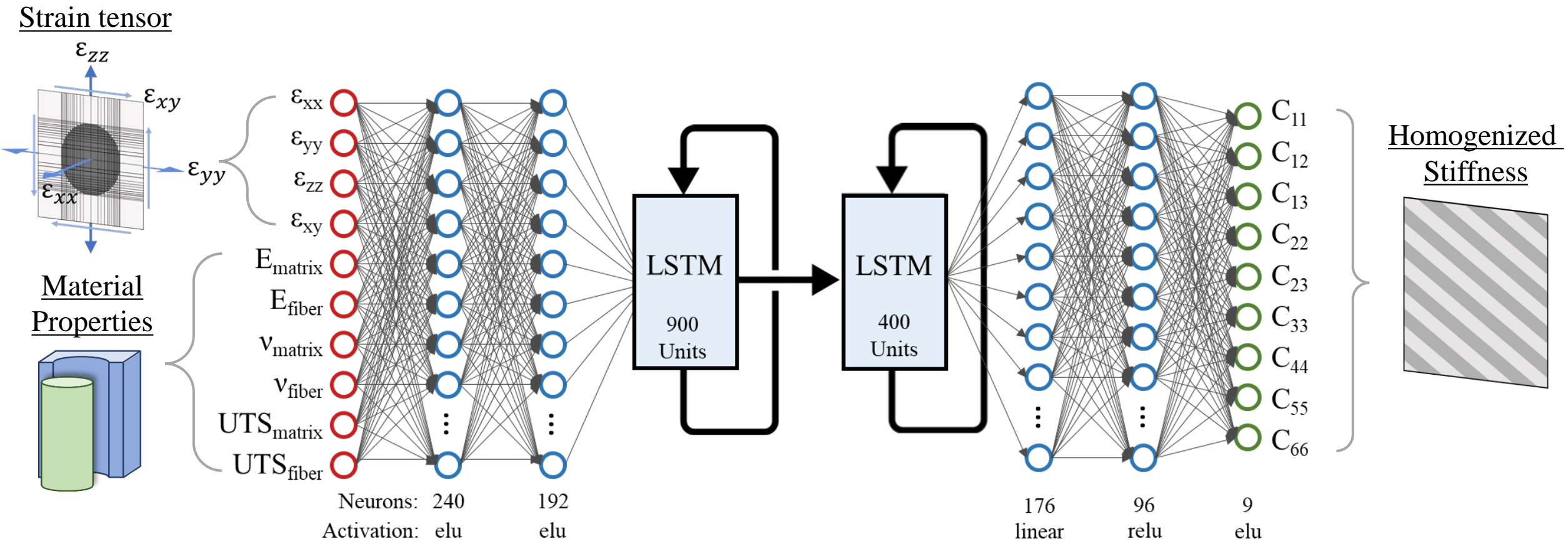

Surrogate Modeling

2×2 RUC $[0^\circ, 32.5^\circ, -32.5^\circ, 90^\circ, 90^\circ, -32.5^\circ, 32.5^\circ, 0^\circ]$

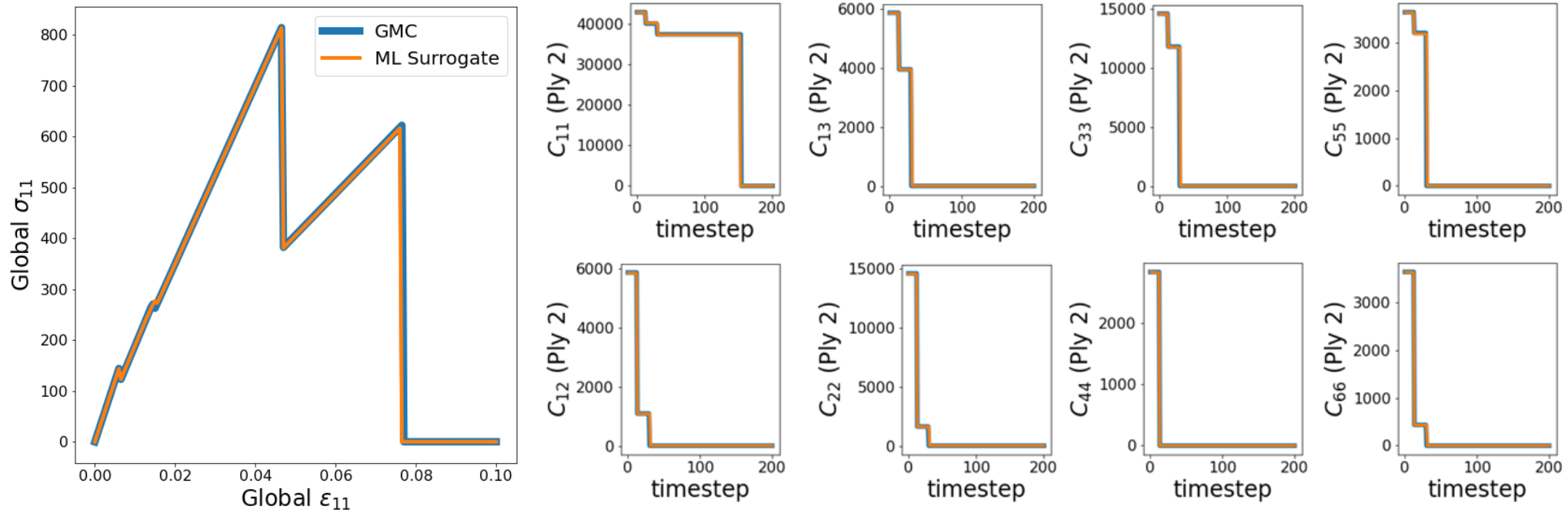

Material Properties

	Fiber	Matrix
E	75 GPa	4 GPa
v	0.25	0.35
UTS	3,500 MPa	60 MPa

Laminate Configuration

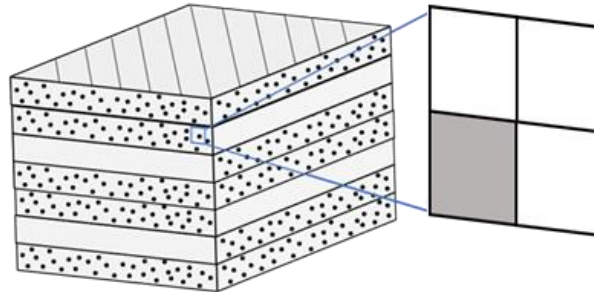

Accuracy Results

	MAE	R ²
Global Stress	8.6 MPa	0.96
Homogenized C	0.4 MPa	0.999997

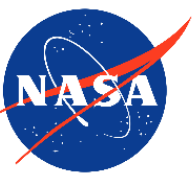

Conclusion

Most technology is limited by available materials

Batteries, jet engines, spaceships, processors, wind turbines, iron man suits

Accelerating materials development accelerates the future

Materials Informatics is accelerating materials development