



Designing a Software Architecture for the Precision Assembly of Space Structures

Benjamin N. Kelley, John R. Cooper, Javier Puig Navarro,
Matthew P. Vaughan, Walter J. Waltz, B. Danette Allen, and William R. Doggett

NASA Langley Research Center, Hampton, VA, 23681, USA

Thea V. Avila, A. Kyle McQuarry, Andrew Miloslavsky,
Sherif A. Shazly, Robert M. Slick, and Ralph A. Williams

Analytical Mechanics Associates Inc., Hampton, VA, 23666, USA

iSAT 20m class Instrument

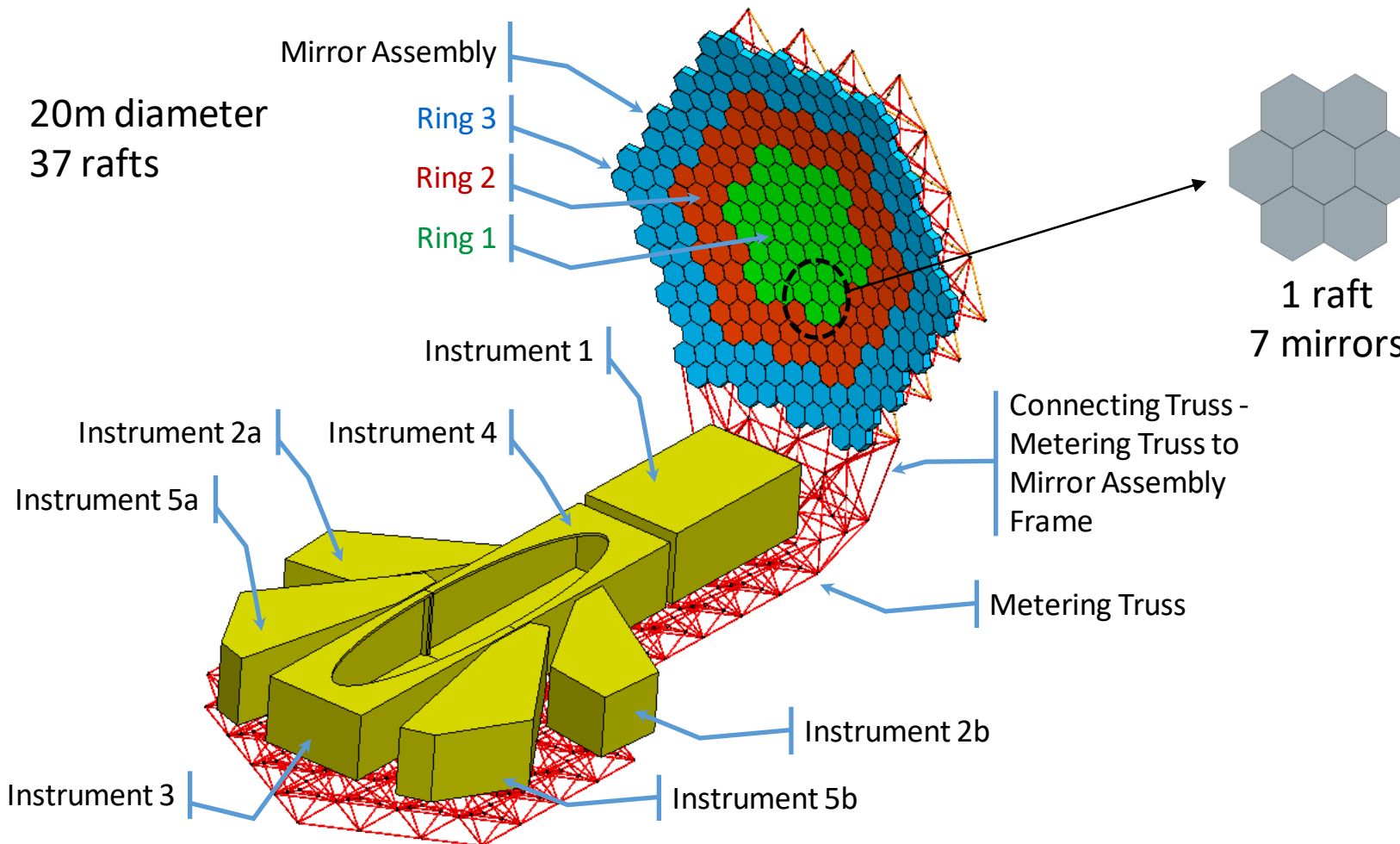

Tri-Truss

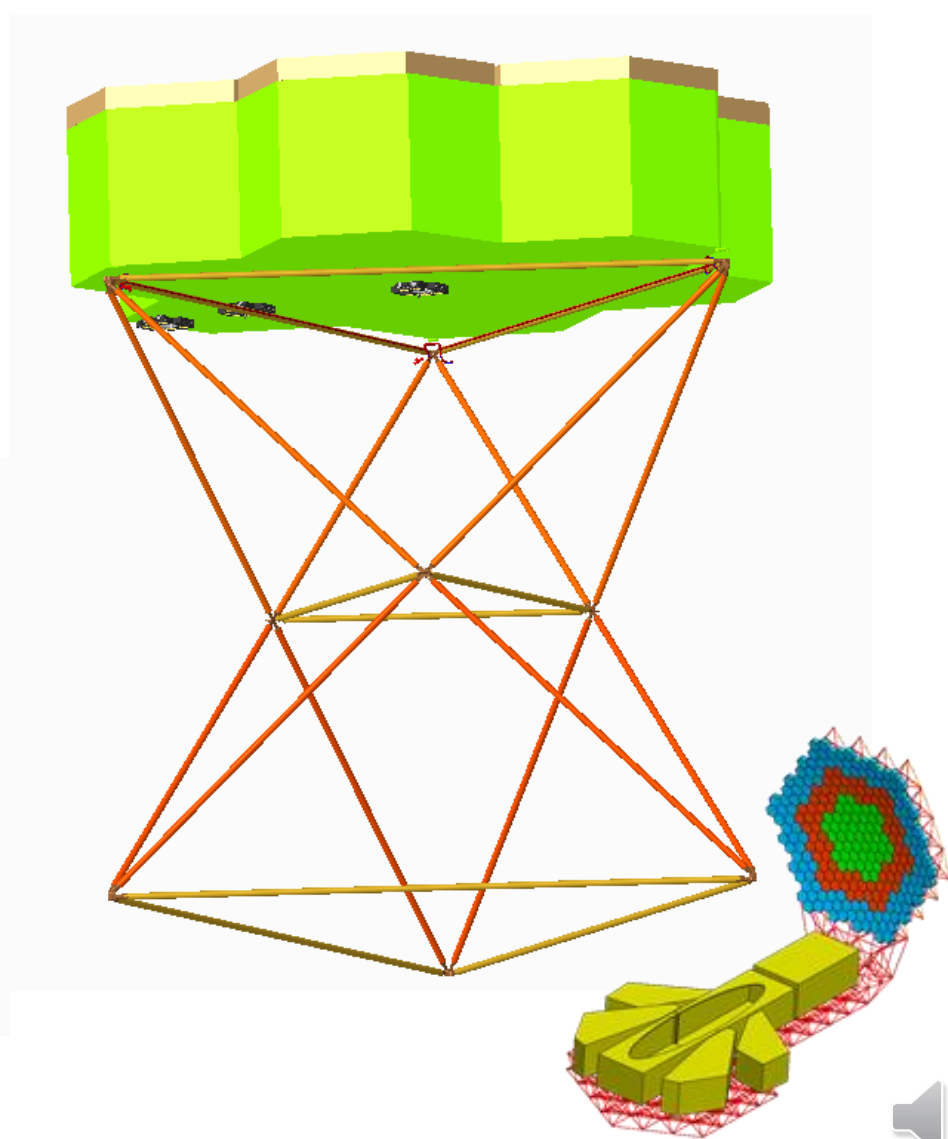
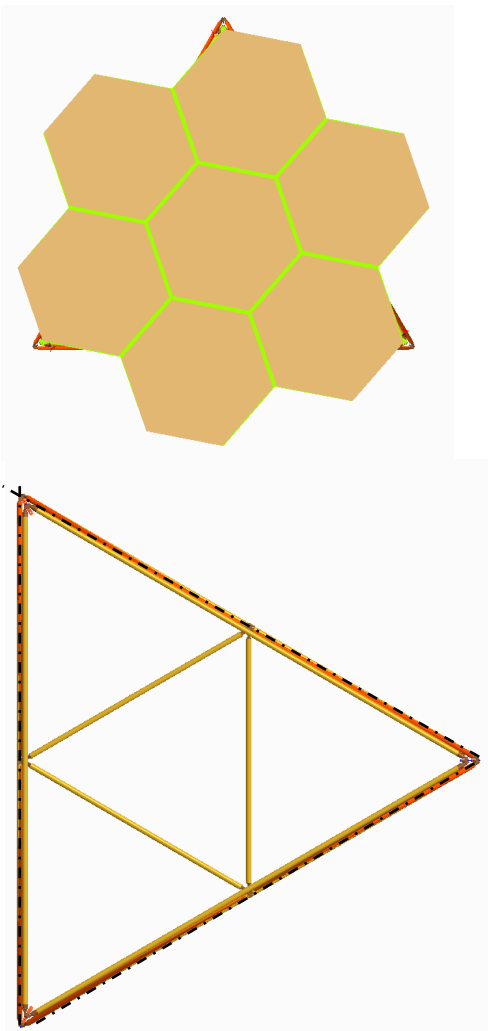
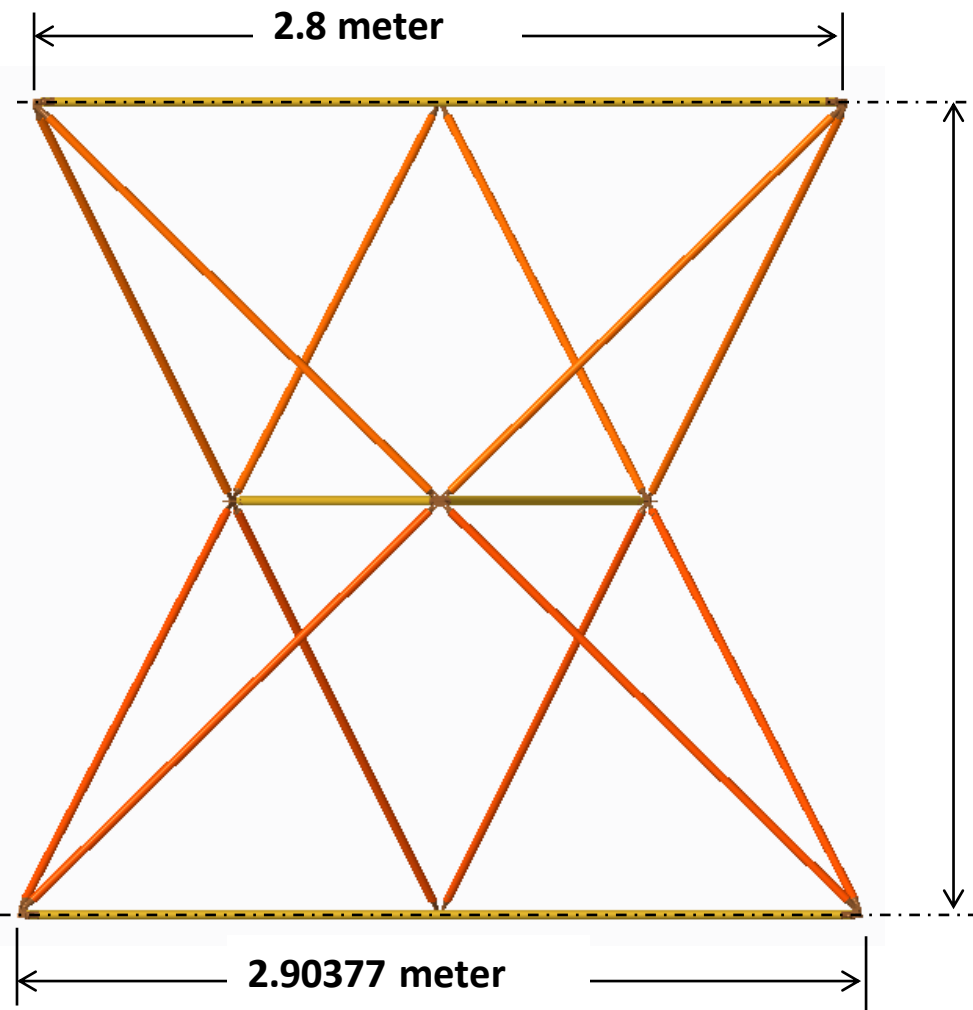

Tri-Truss Connection

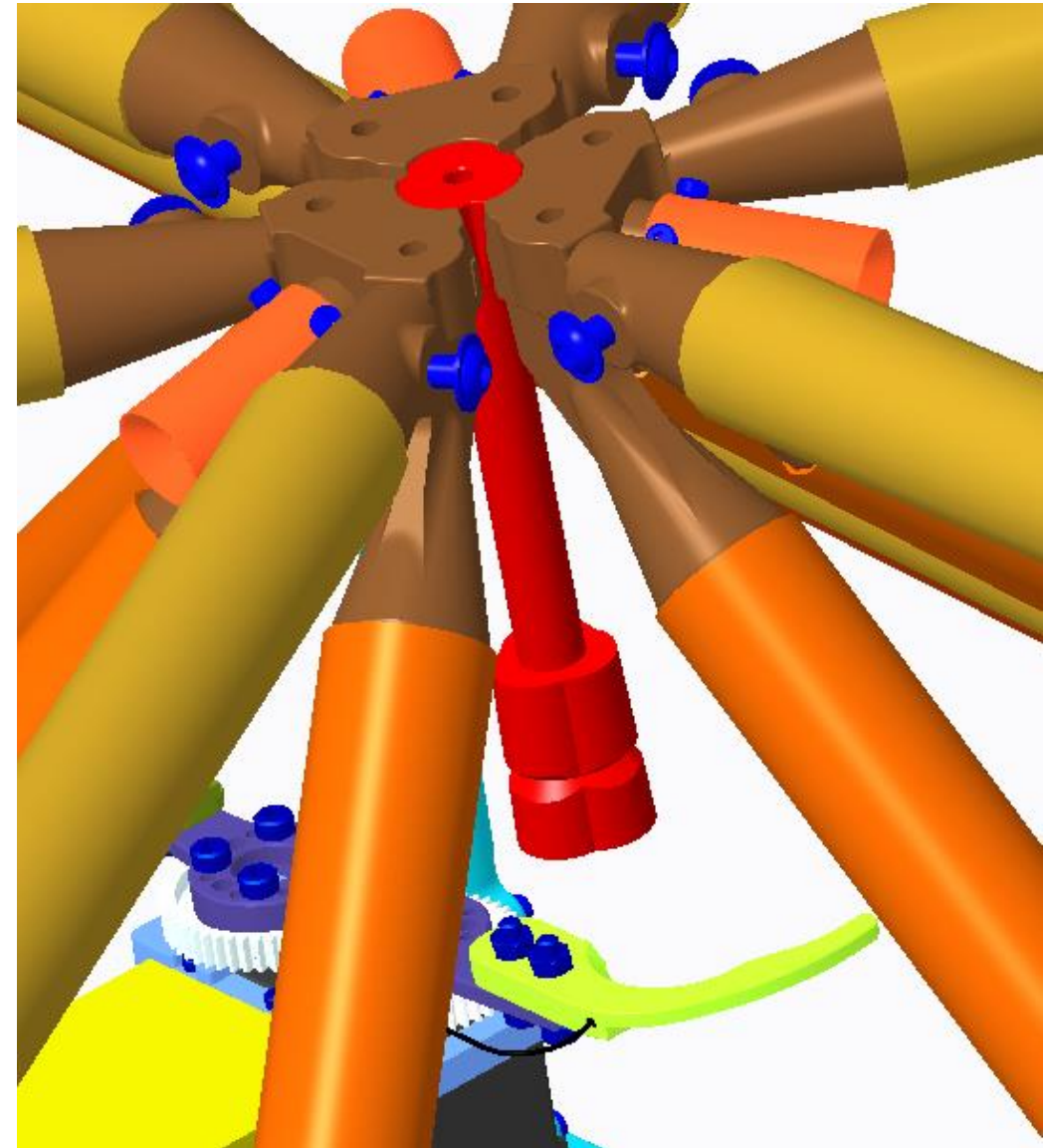
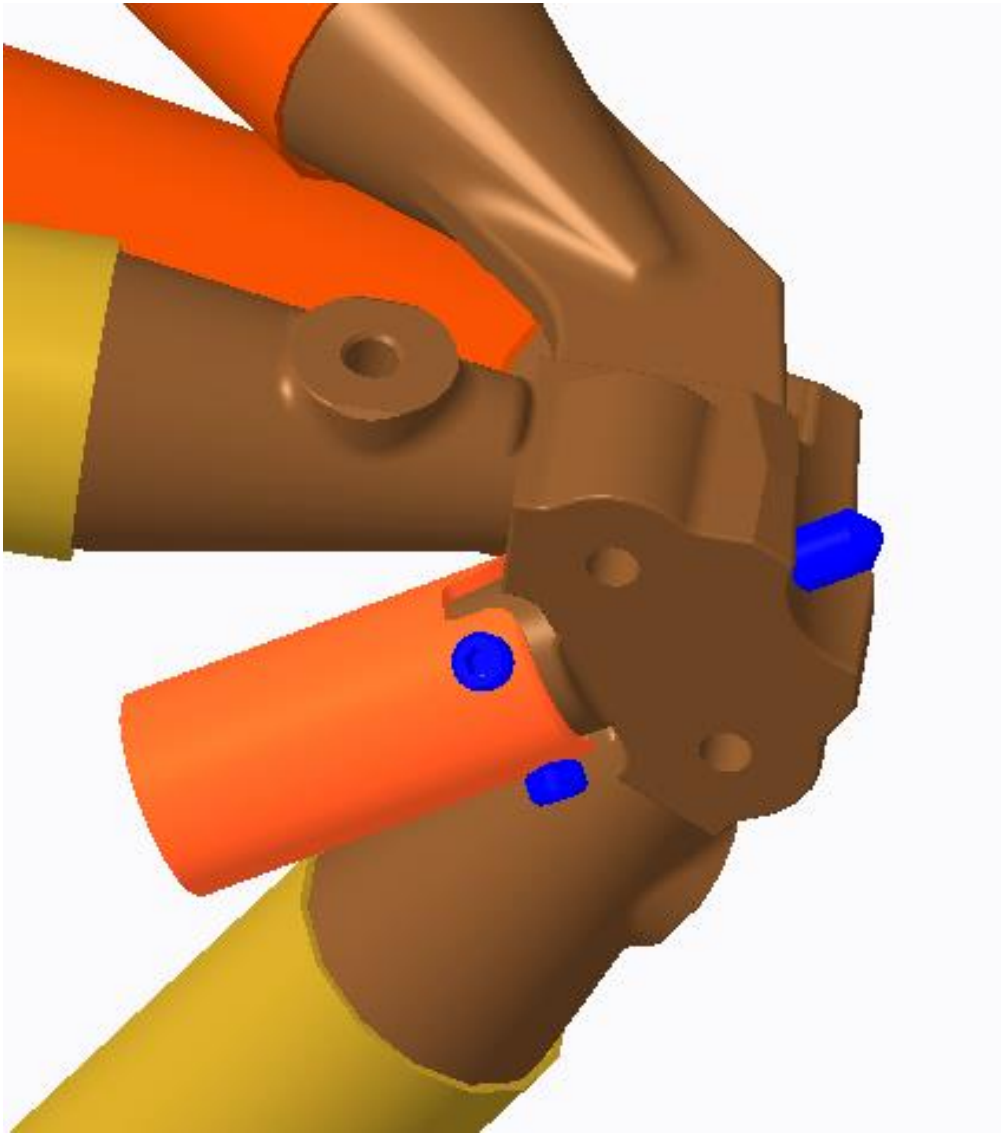

Truss Deployment

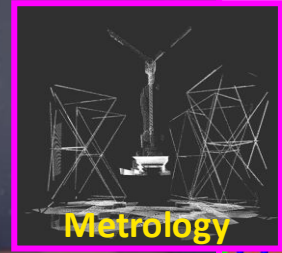
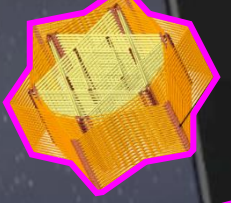

Metrology

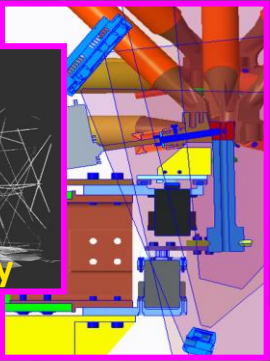

Fine Placement and assembly

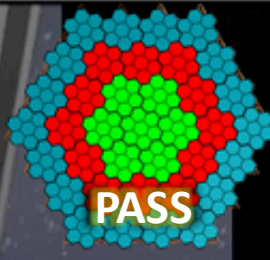

PASS

Asset identification and localization

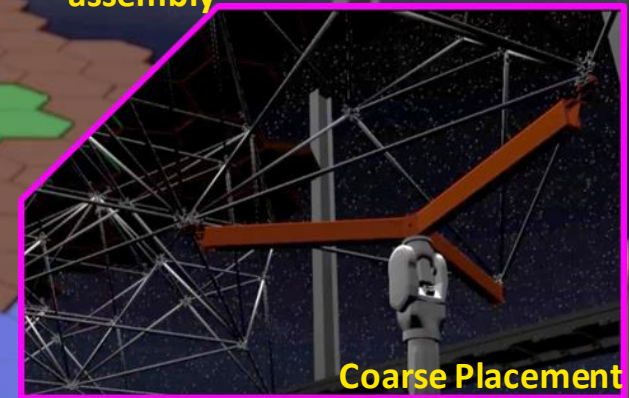

Coarse Placement

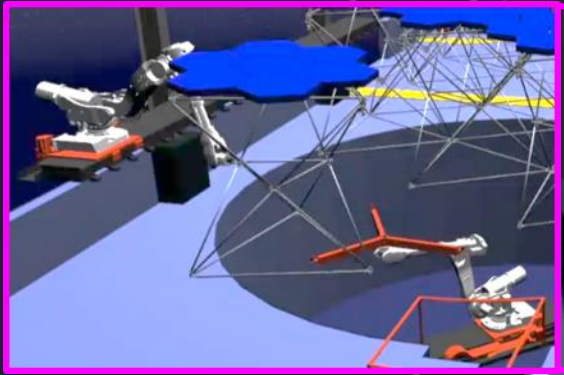

Collaborative handoff to Coarse Placement Agent

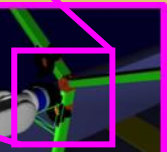

Quick Change

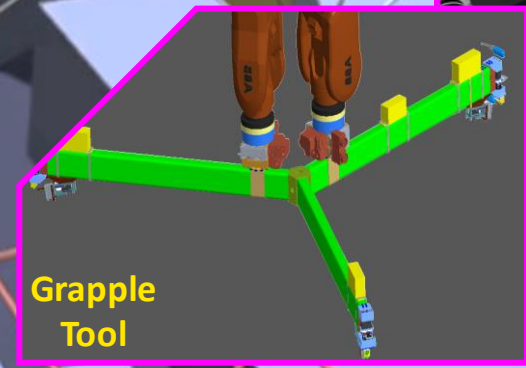

Grapple Tool



Truss Deployment

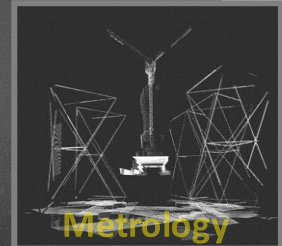
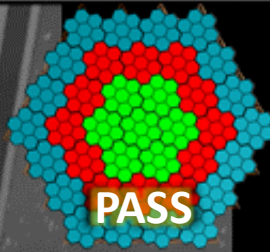
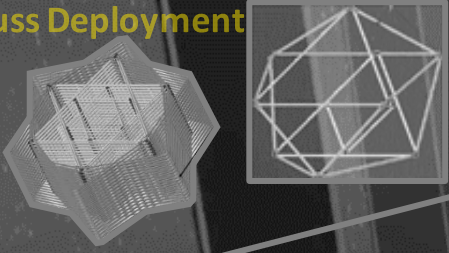

Metrology

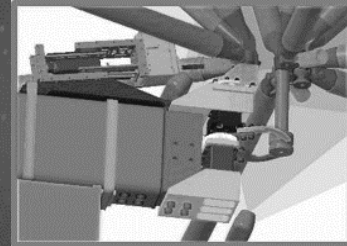

Fine Placement and assembly

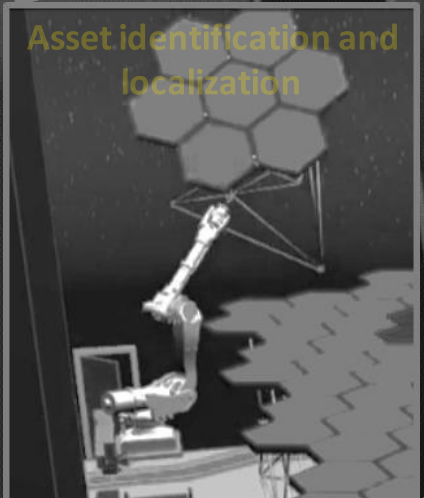

Asset identification and localization



Coarse Placement

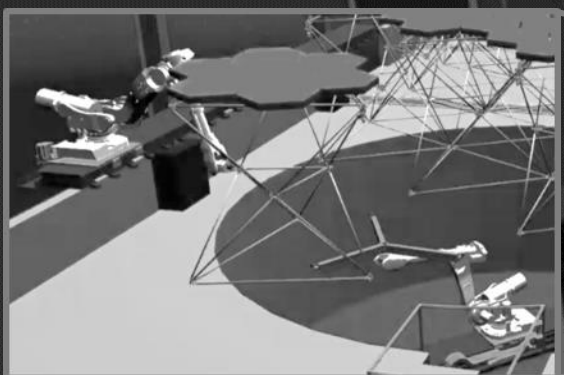

Collaborative handoff to Course Placement Agent

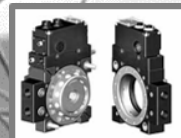

Quick Change

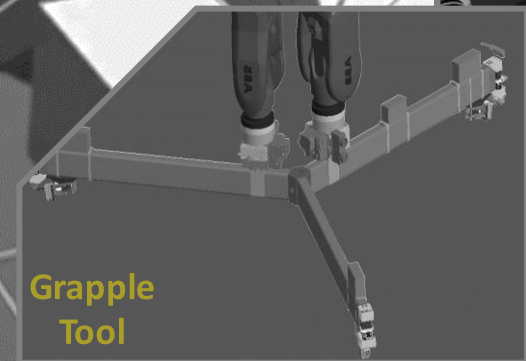

Grapple Tool

Truss Deployment

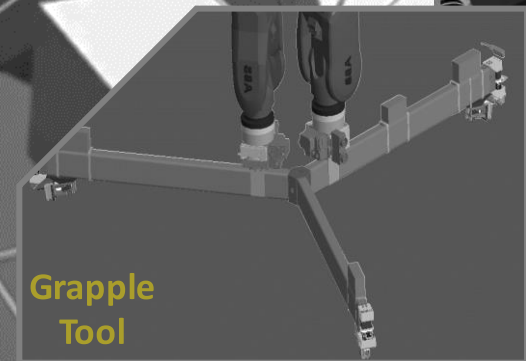
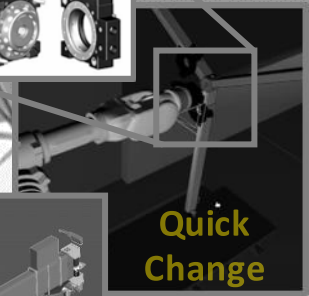
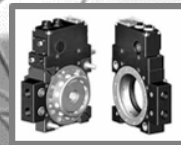
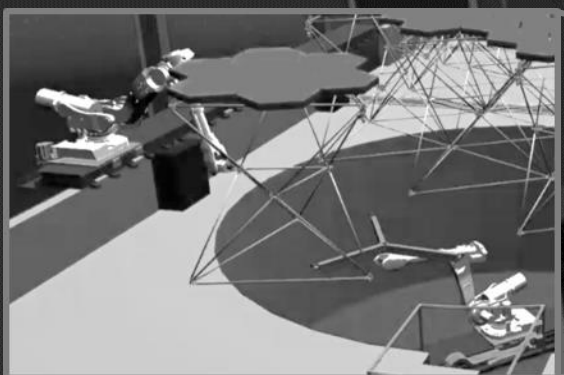
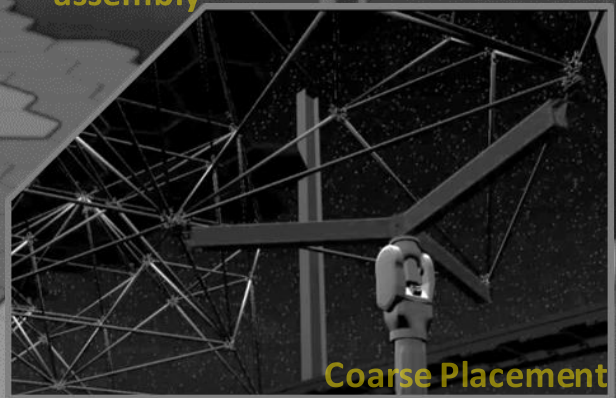
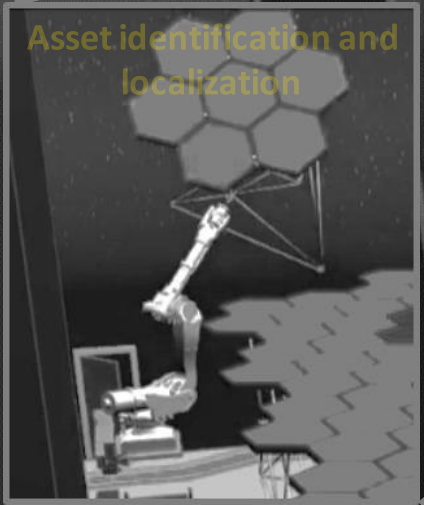
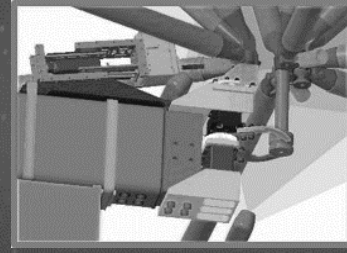
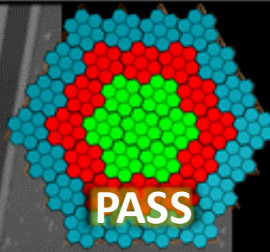
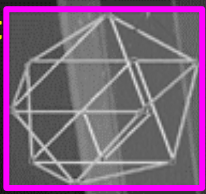
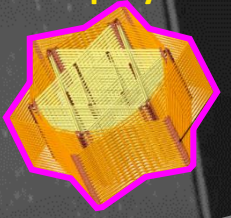

Truss Deployment

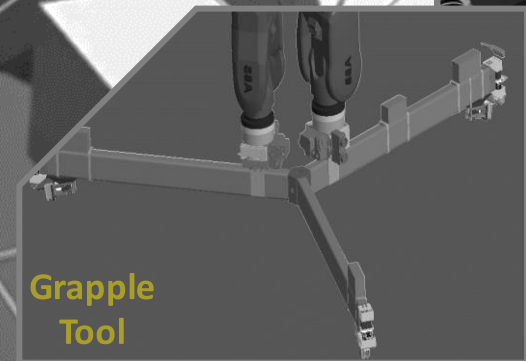
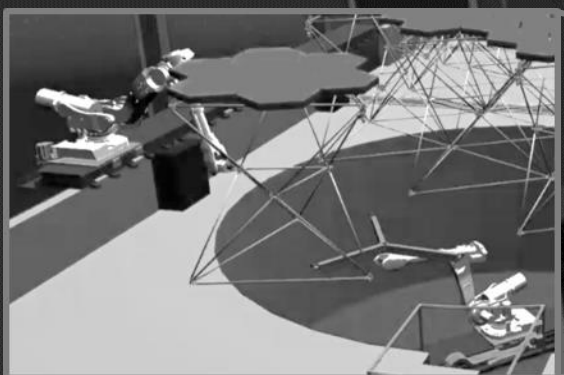
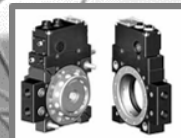
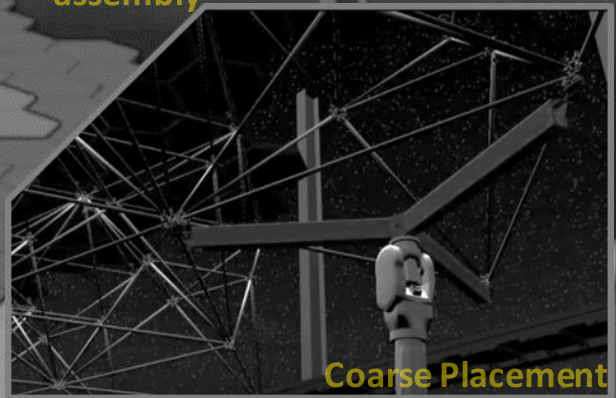
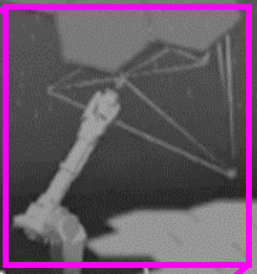
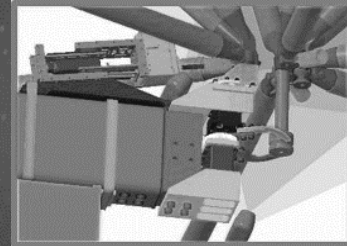
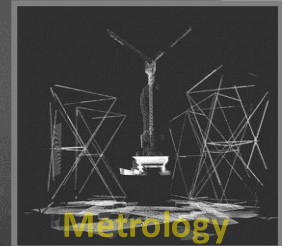
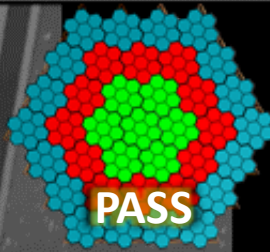
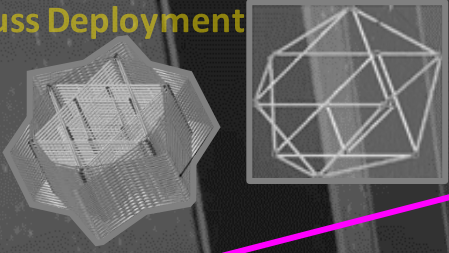

Truss Deployment

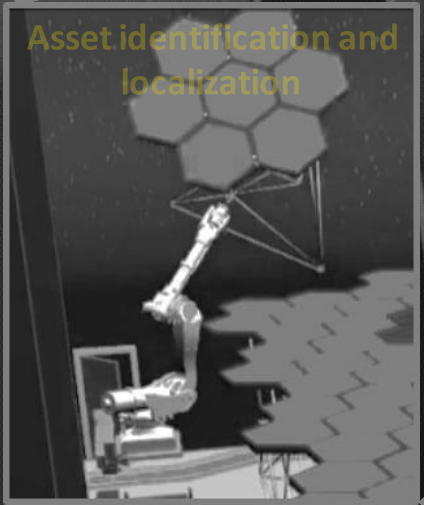
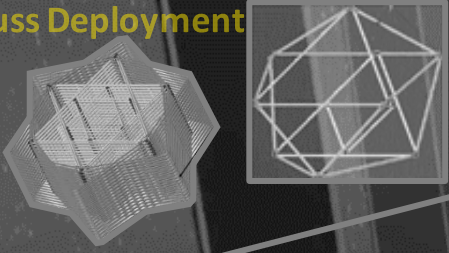

Asset identification and localization

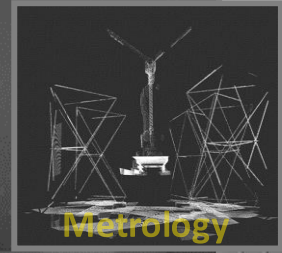

Metrology

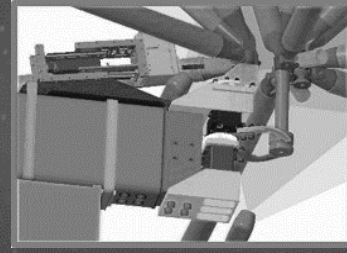

Fine Placement and assembly

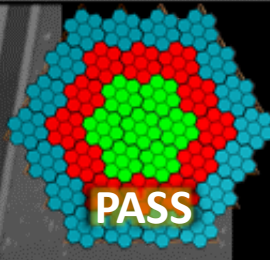

PASS



Coarse Placement

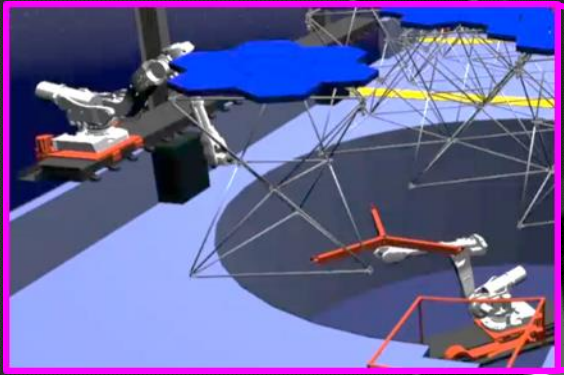

Collaborative handoff to Course Placement Agent

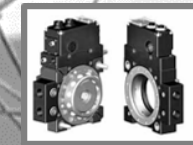

Quick Change

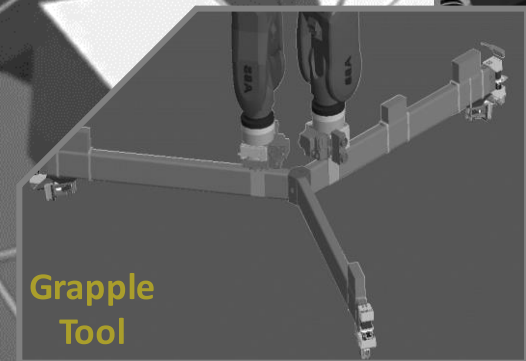

Grapple Tool



Truss Deployment

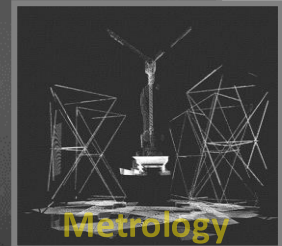
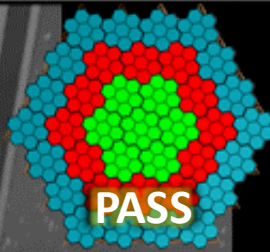
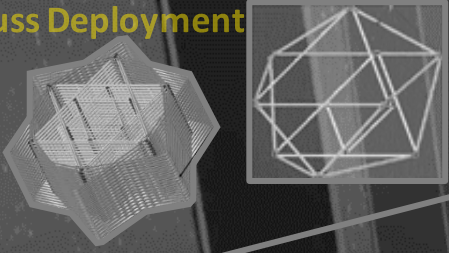

Metrology

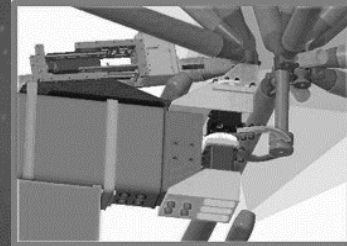

Fine Placement and assembly

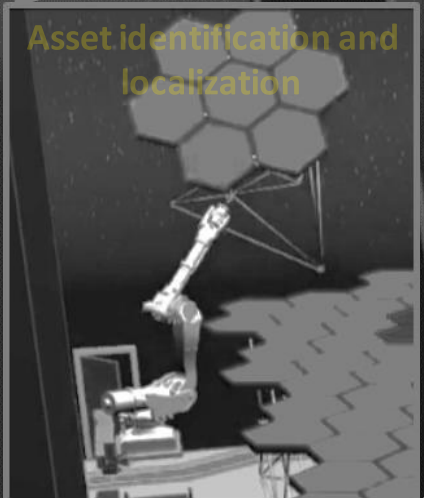

Asset identification and localization

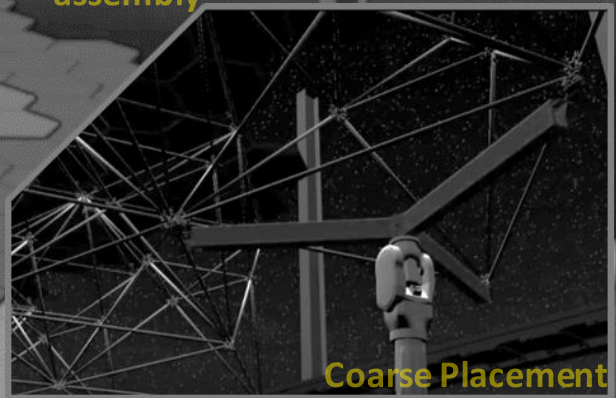

Coarse Placement

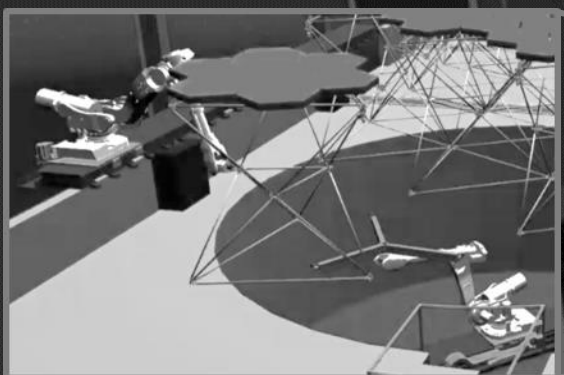

Collaborative handoff to Course Placement Agent

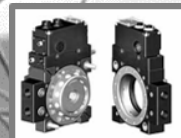

Quick Change

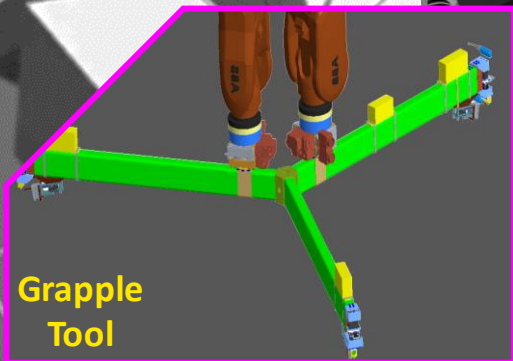

Grapple Tool



Truss Deployment

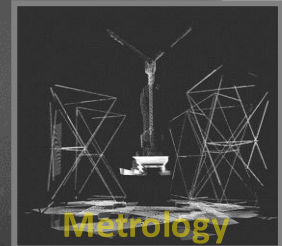
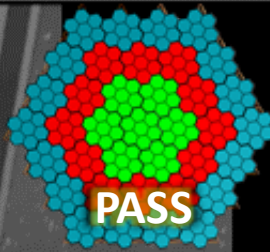
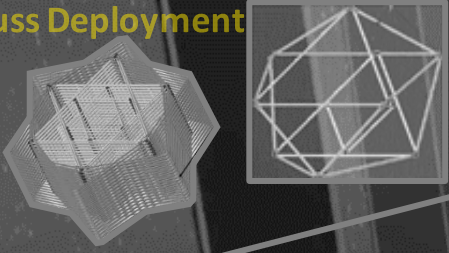

Metrology

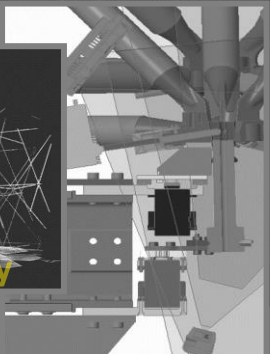

Fine Placement and assembly

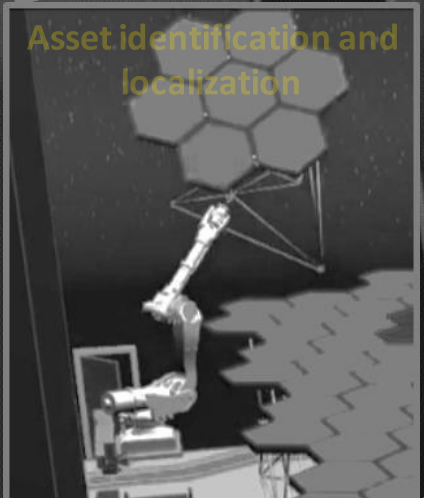

Asset identification and localization



Coarse Placement

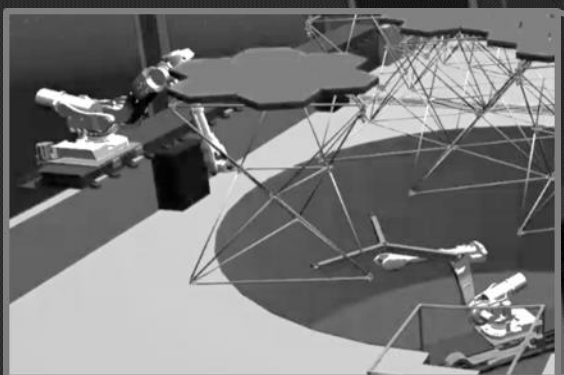

Collaborative handoff to Course Placement Agent



Quick Change

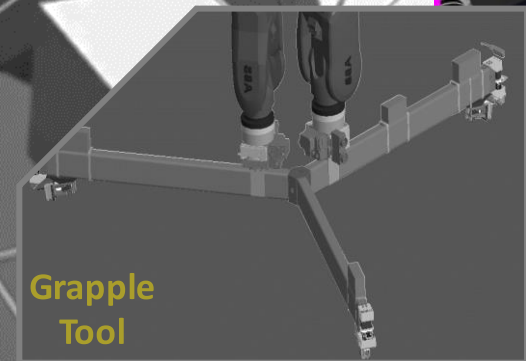

Grapple Tool



Truss Deployment

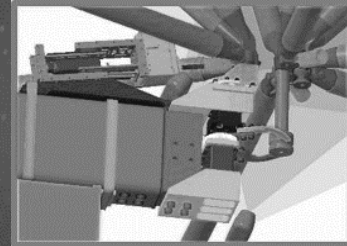
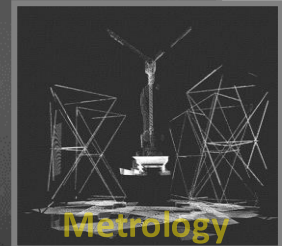
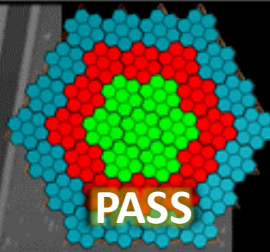
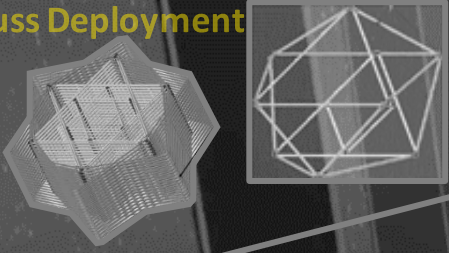

Fine Placement and assembly

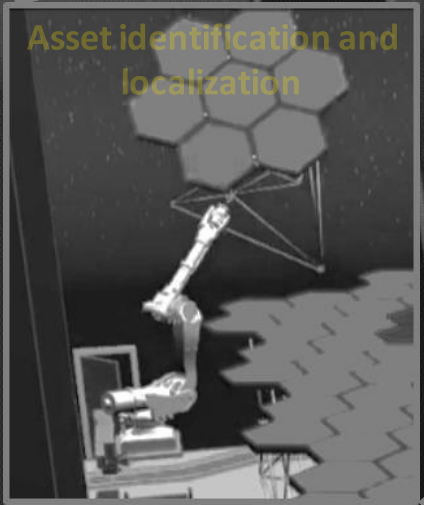

Asset identification and localization



Coarse Placement

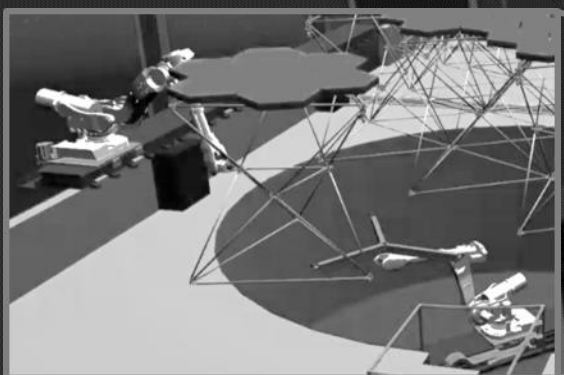

Collaborative handoff to Coarse Placement Agent

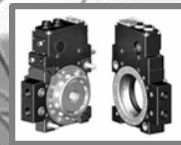

Quick Change

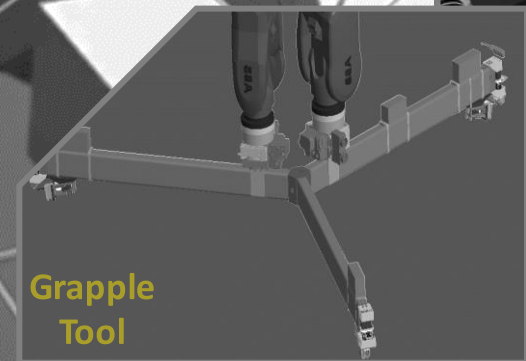

Grapple Tool

Truss Deployment

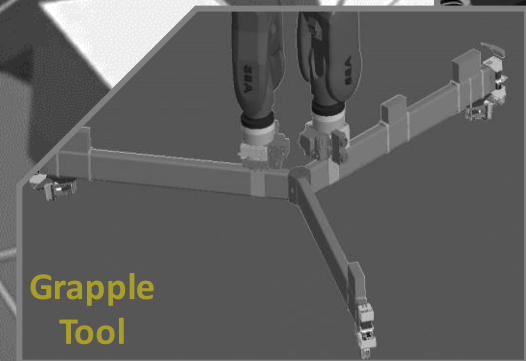
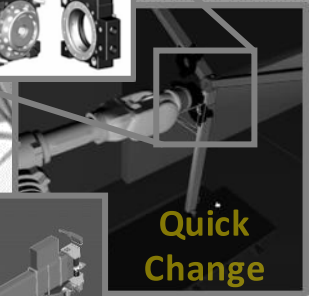
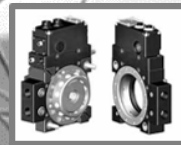
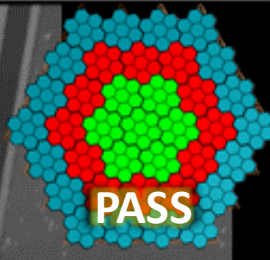
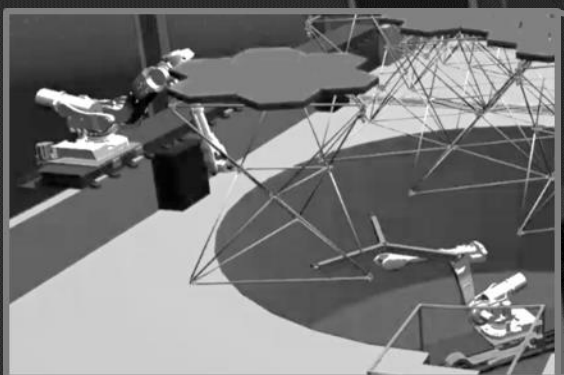
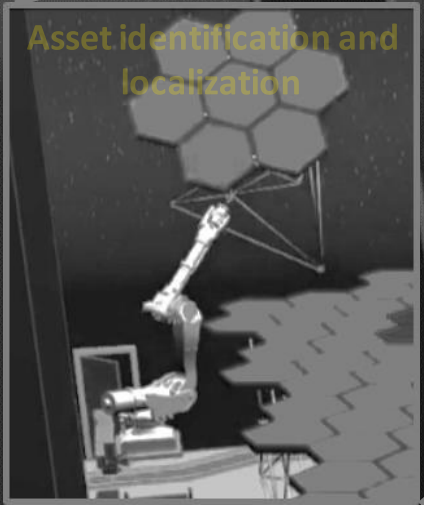
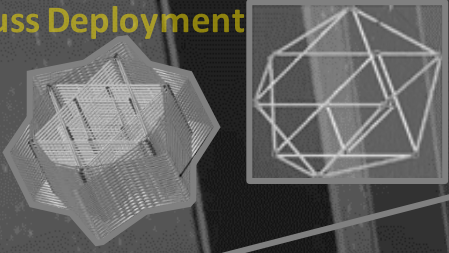

Truss Deployment

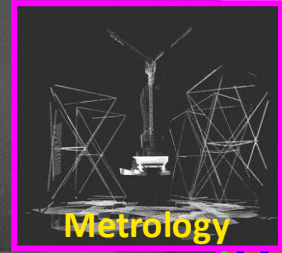
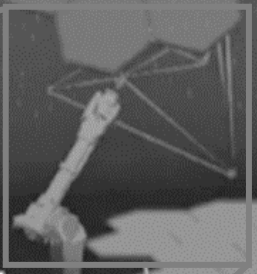
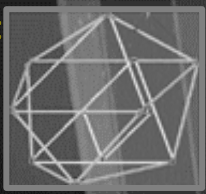
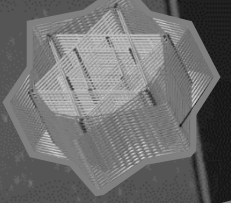

Metrology

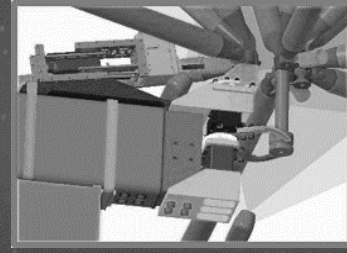
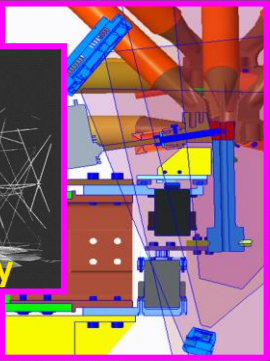

Fine Placement and assembly

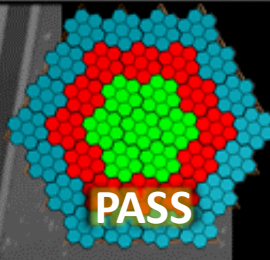

Asset identification and localization

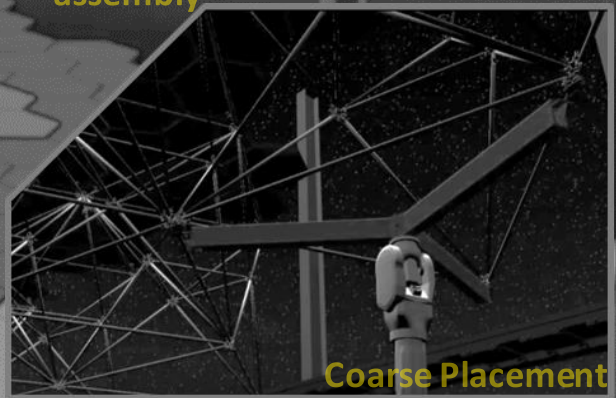
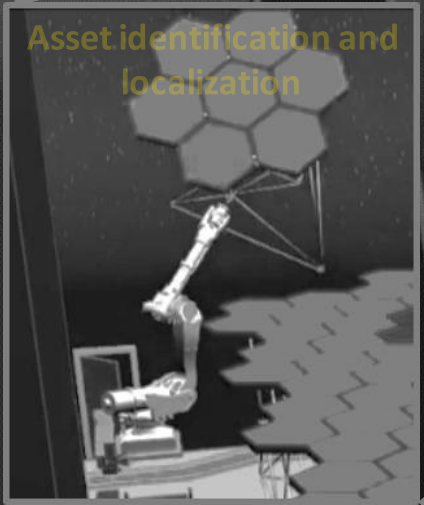

Coarse Placement

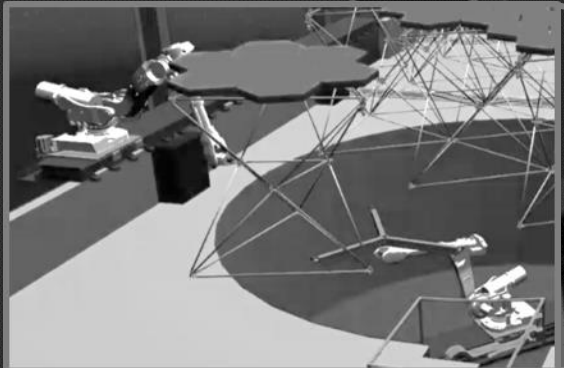

Collaborative handoff to Course Placement Agent

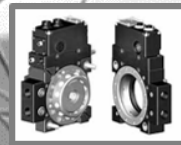

Quick Change

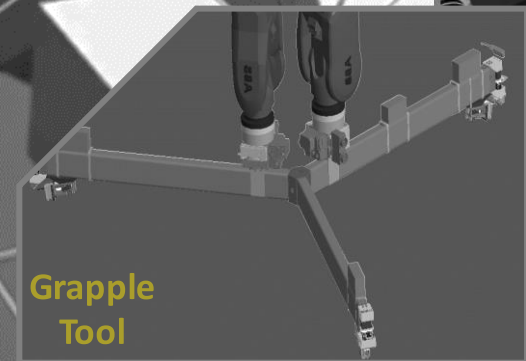

Grapple Tool

Grapple Mechanism

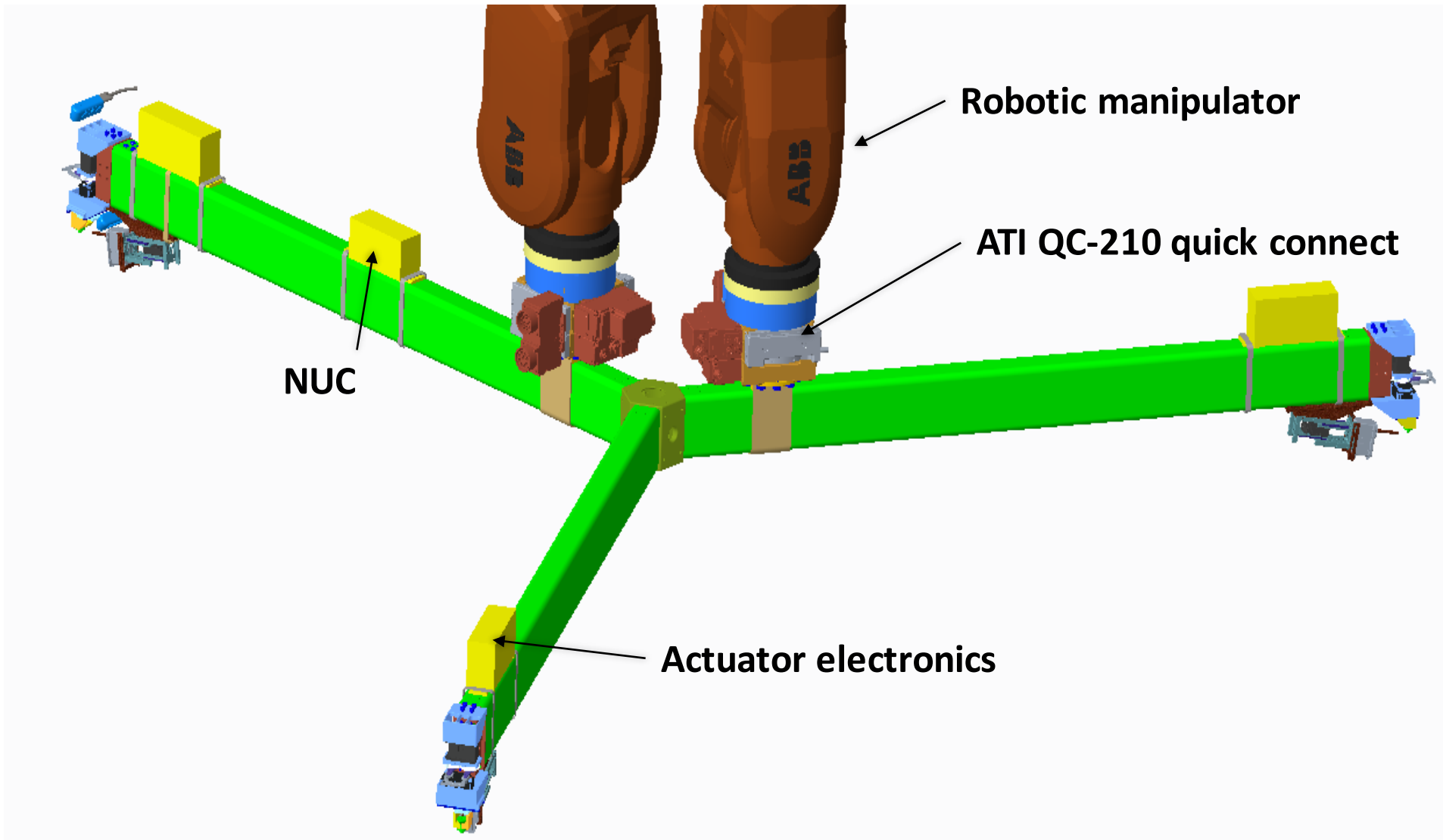

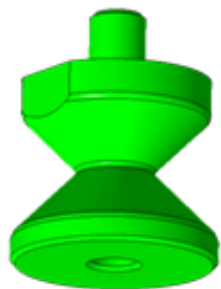

Grapple post

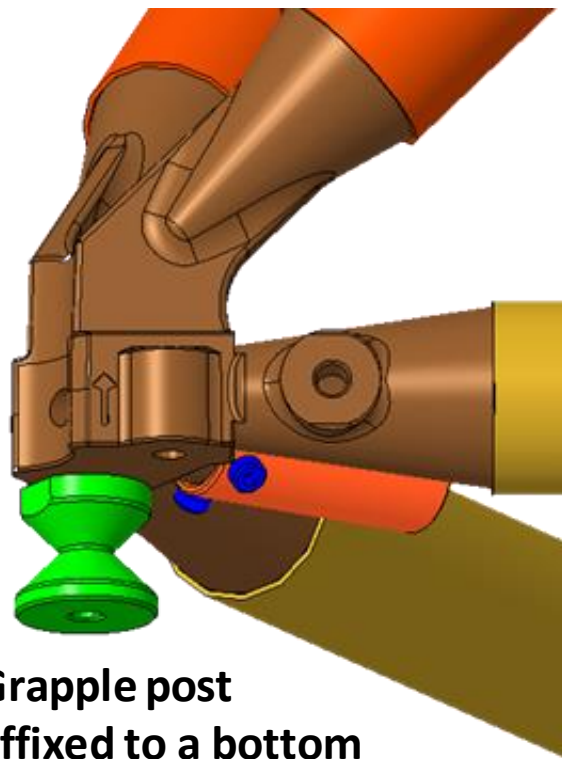

Grapple post affixed to a bottom corner of tri-truss

Grapple attaches to corner nodes

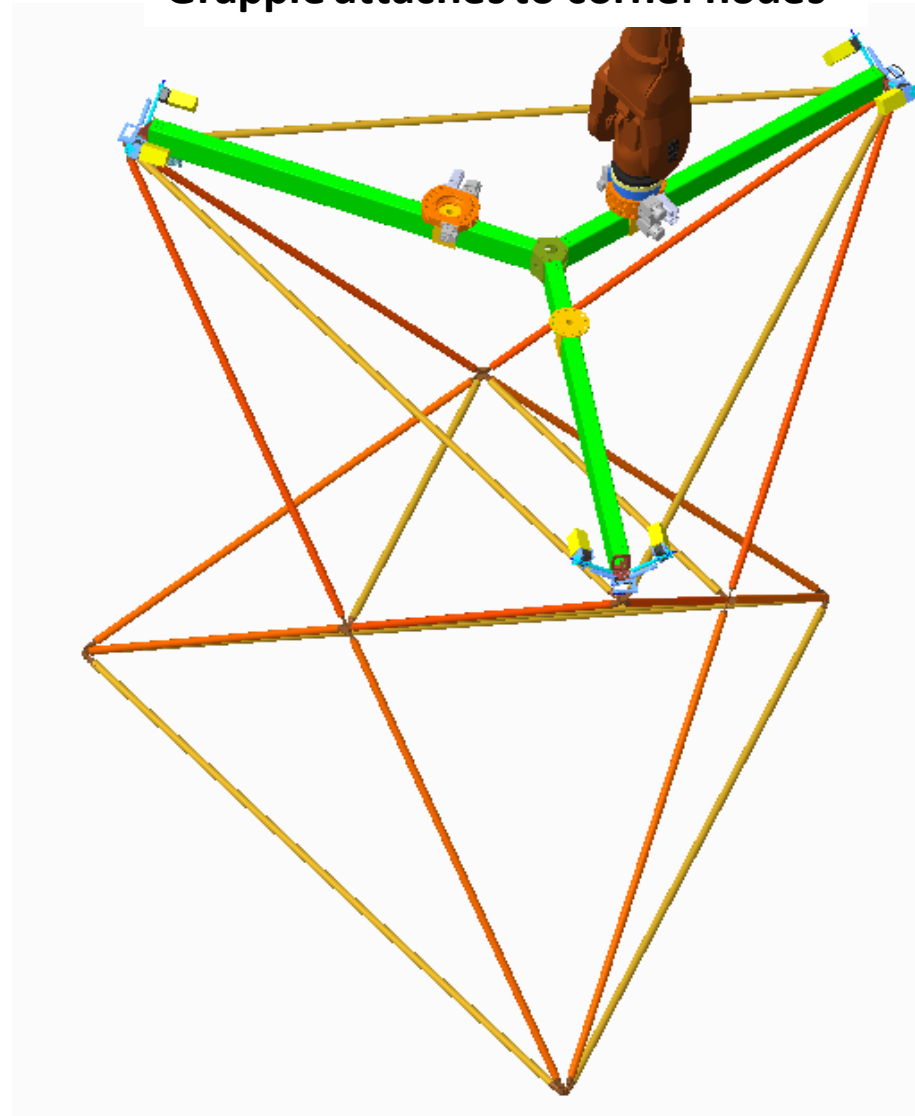

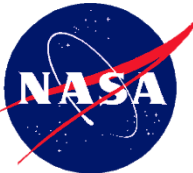

Grapple Mechanism: End Spoke Payload



Langley Research Center

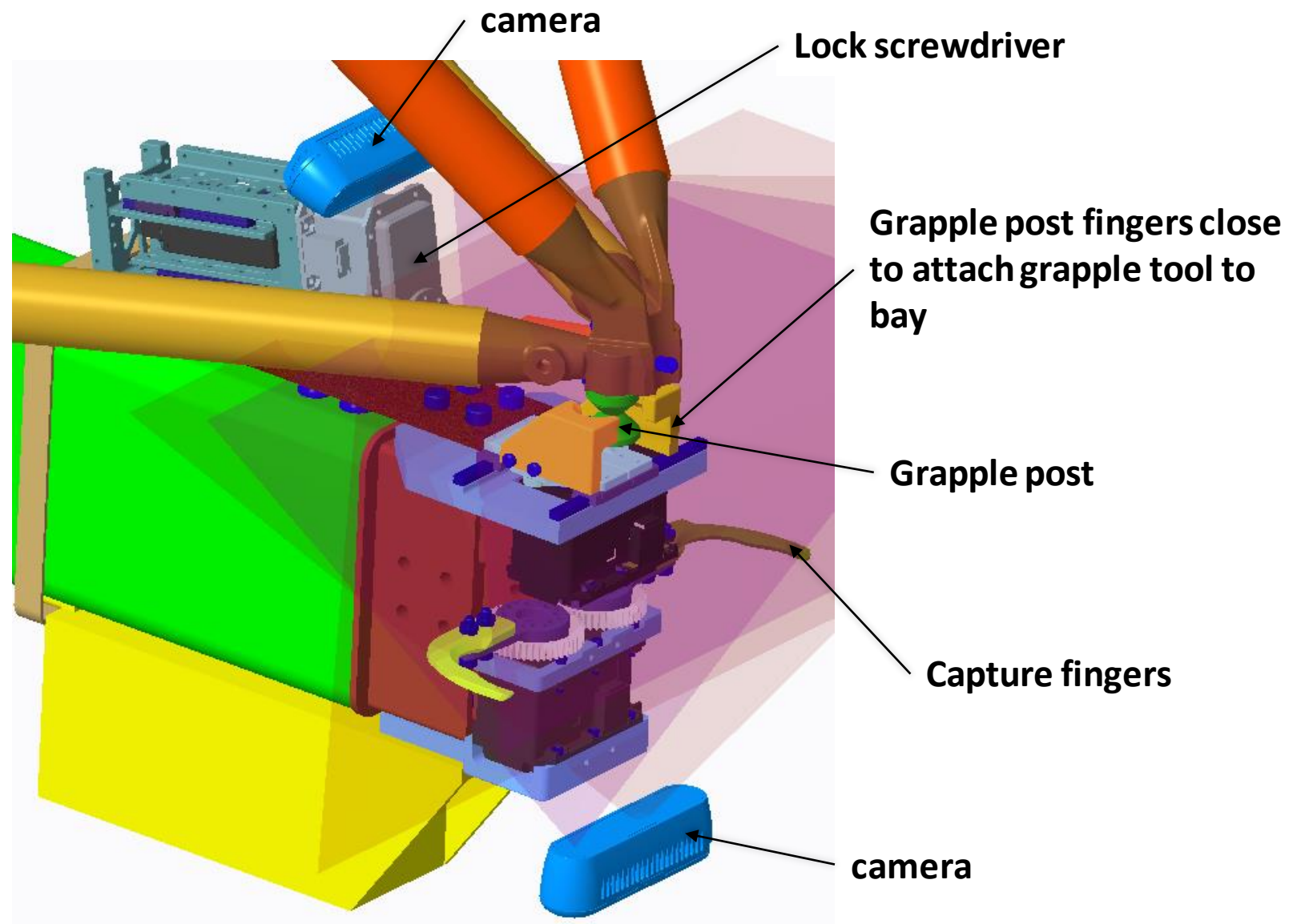

Grapple Mechanism: Metrology

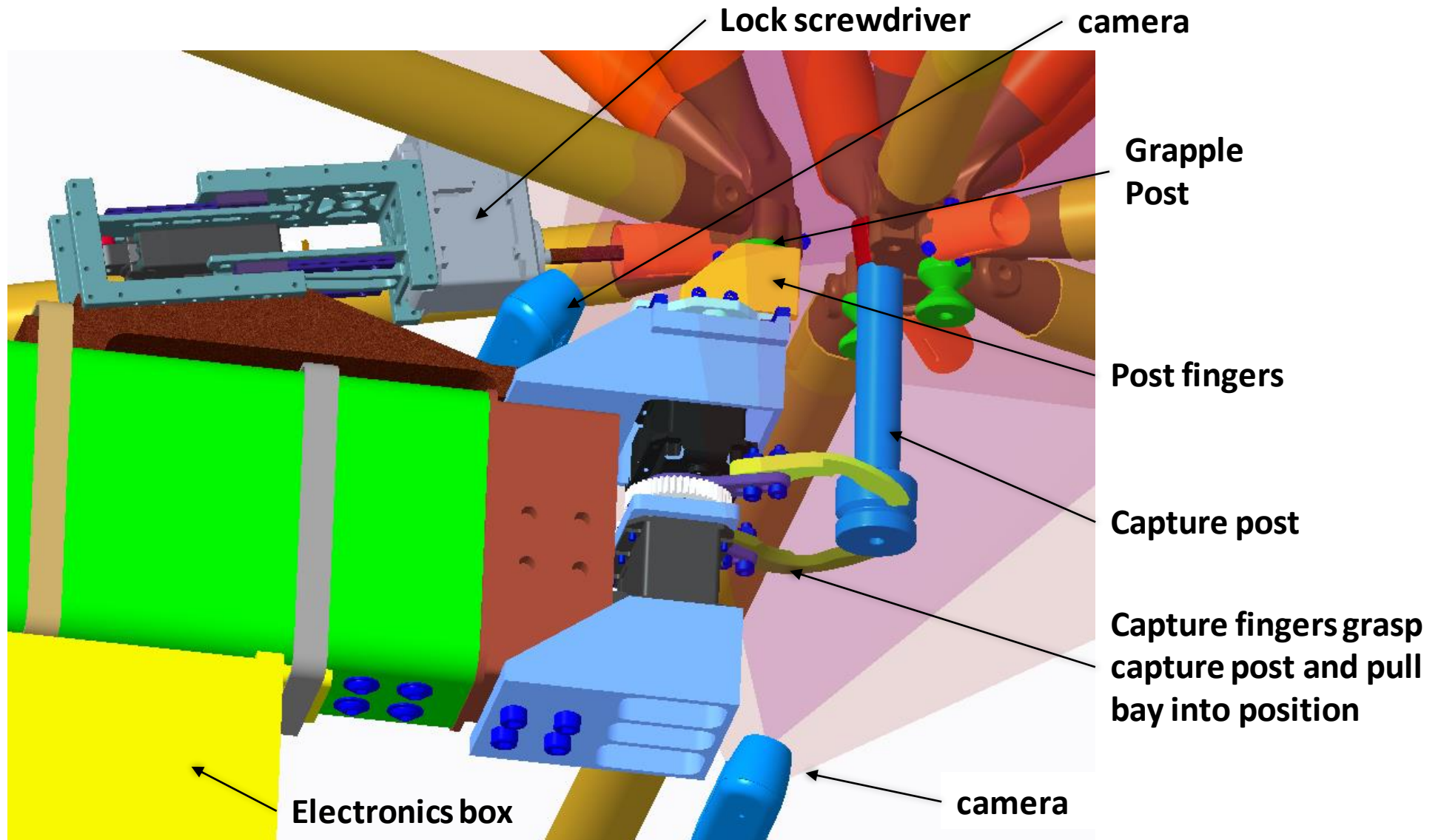

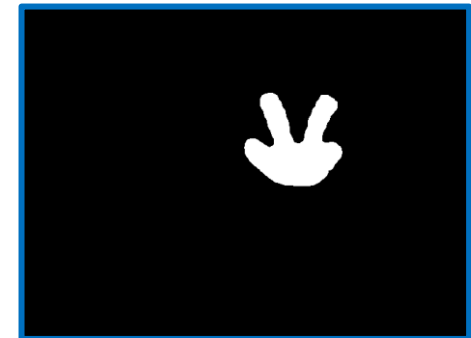
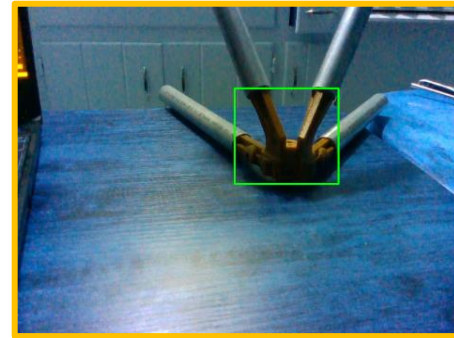
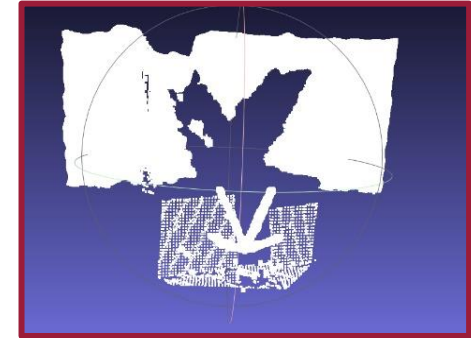
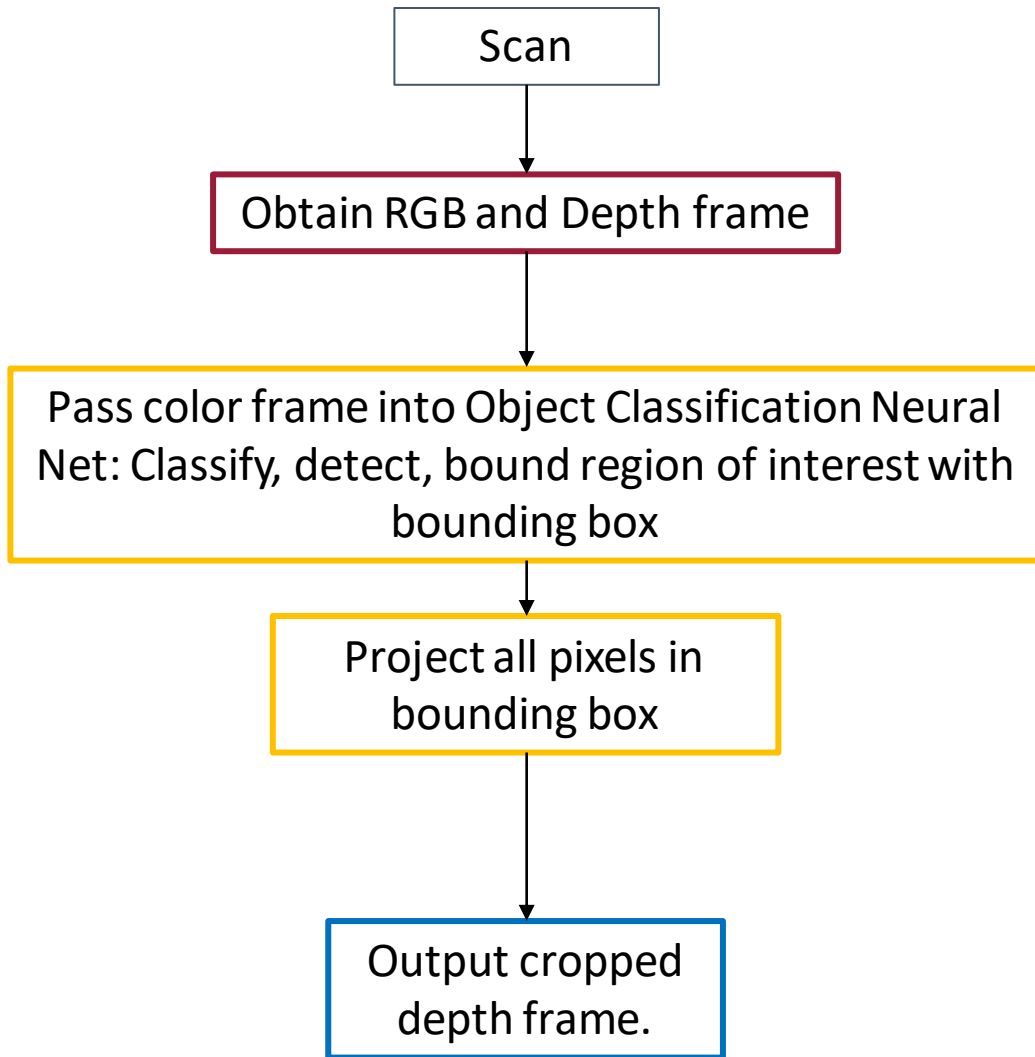

- Develop a set of point cloud representations of the object at different rotations either manually or using a pan-tilt
- Using fitness score provided by registration, select the best fit scan from the model set
- Apply transform from Iterative Closest Point (ICP) to the model to align it within scene
- Return pose

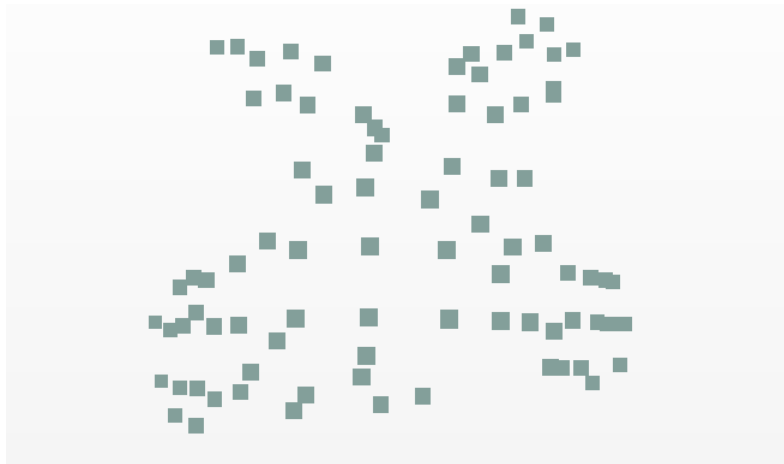

Point Cloud Model of Node

Align? →



Captured Scene Scan

Pose Estimation: Visualization



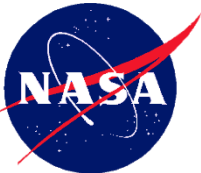

Phase 1 Assembly



Langley Research Center

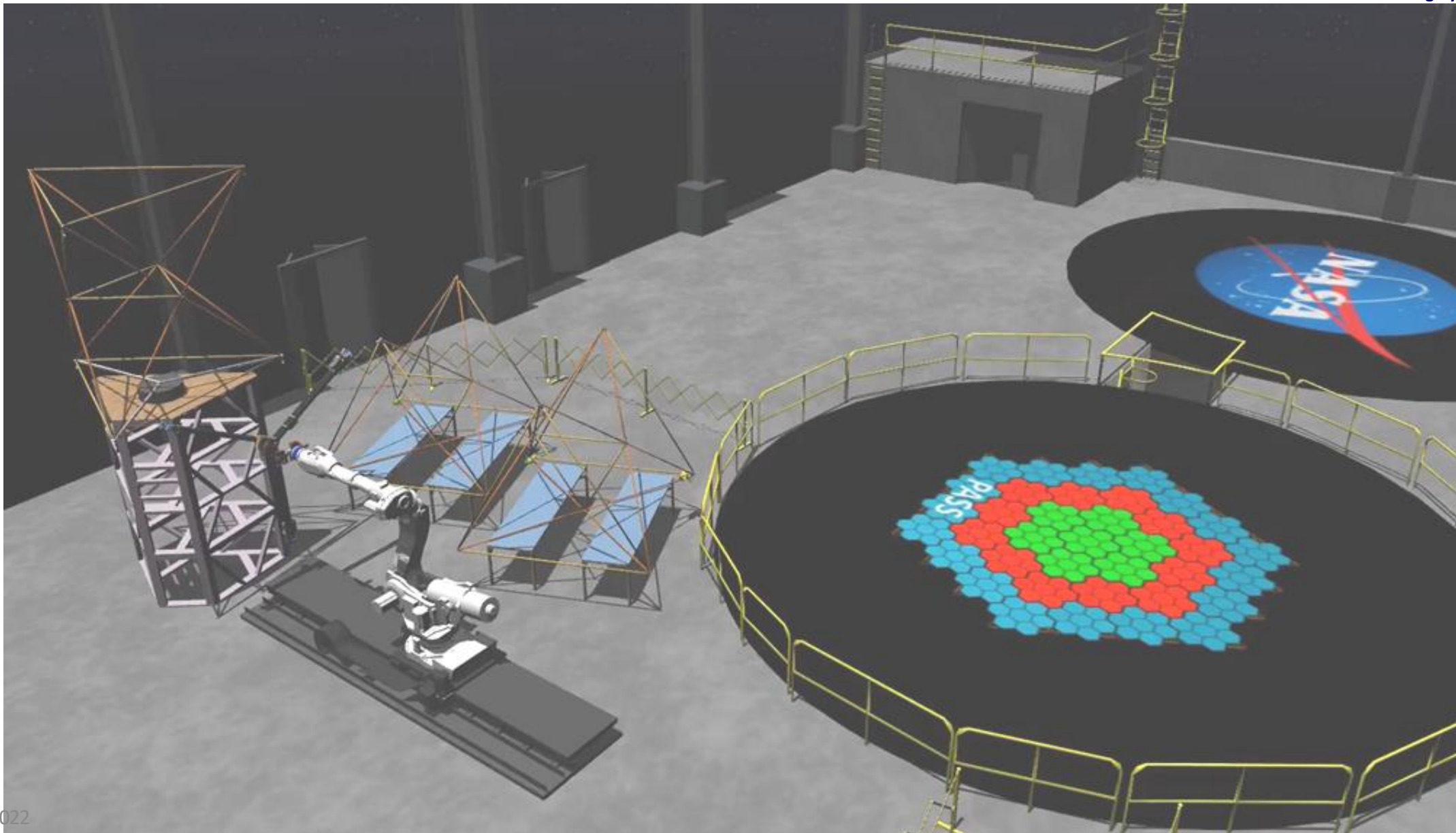

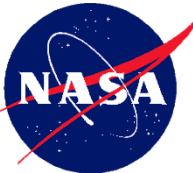

Future Work: ESPA TriTruss Ring Assembly



Langley Research Center

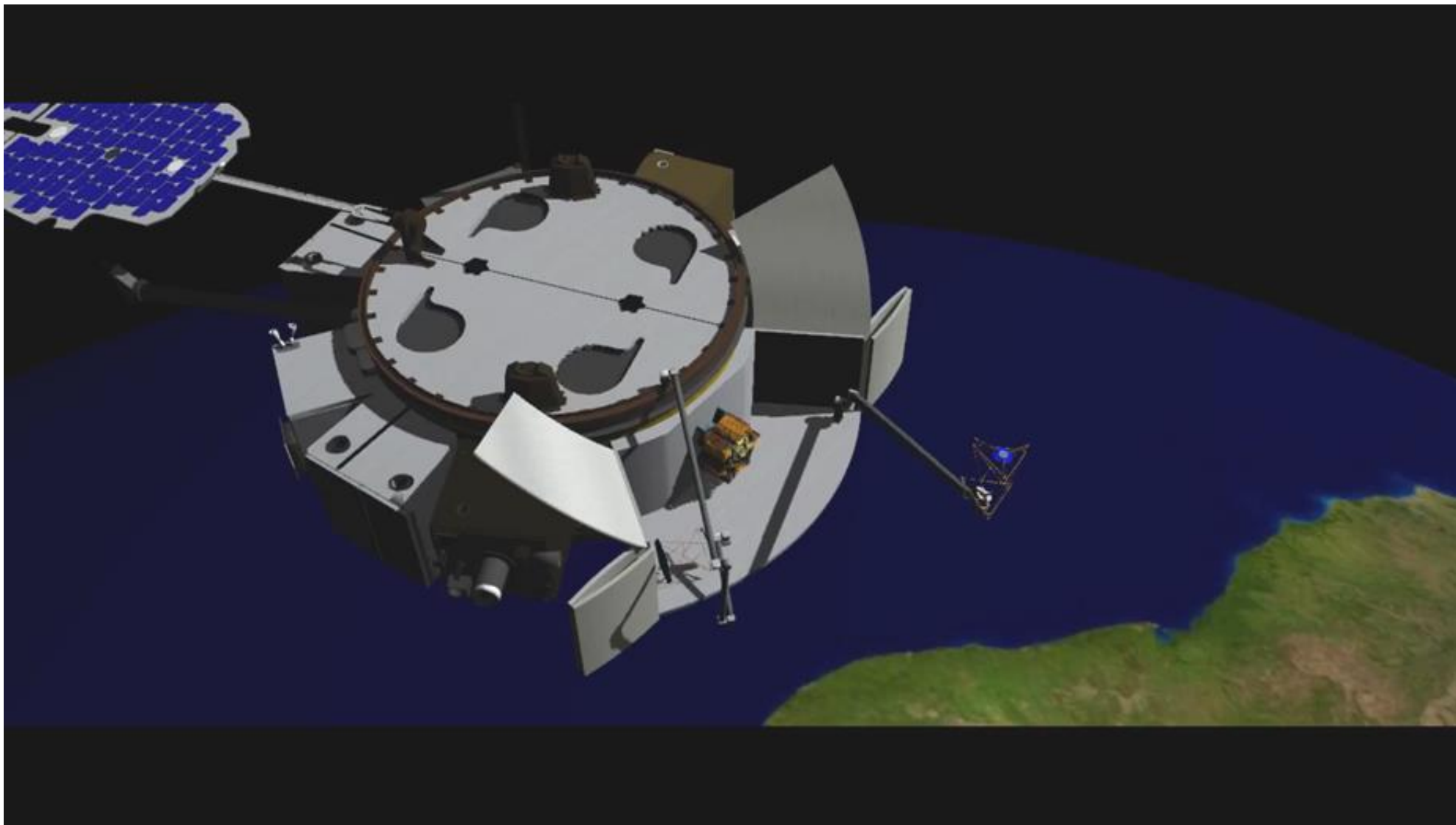



Thank You



Langley Research Center

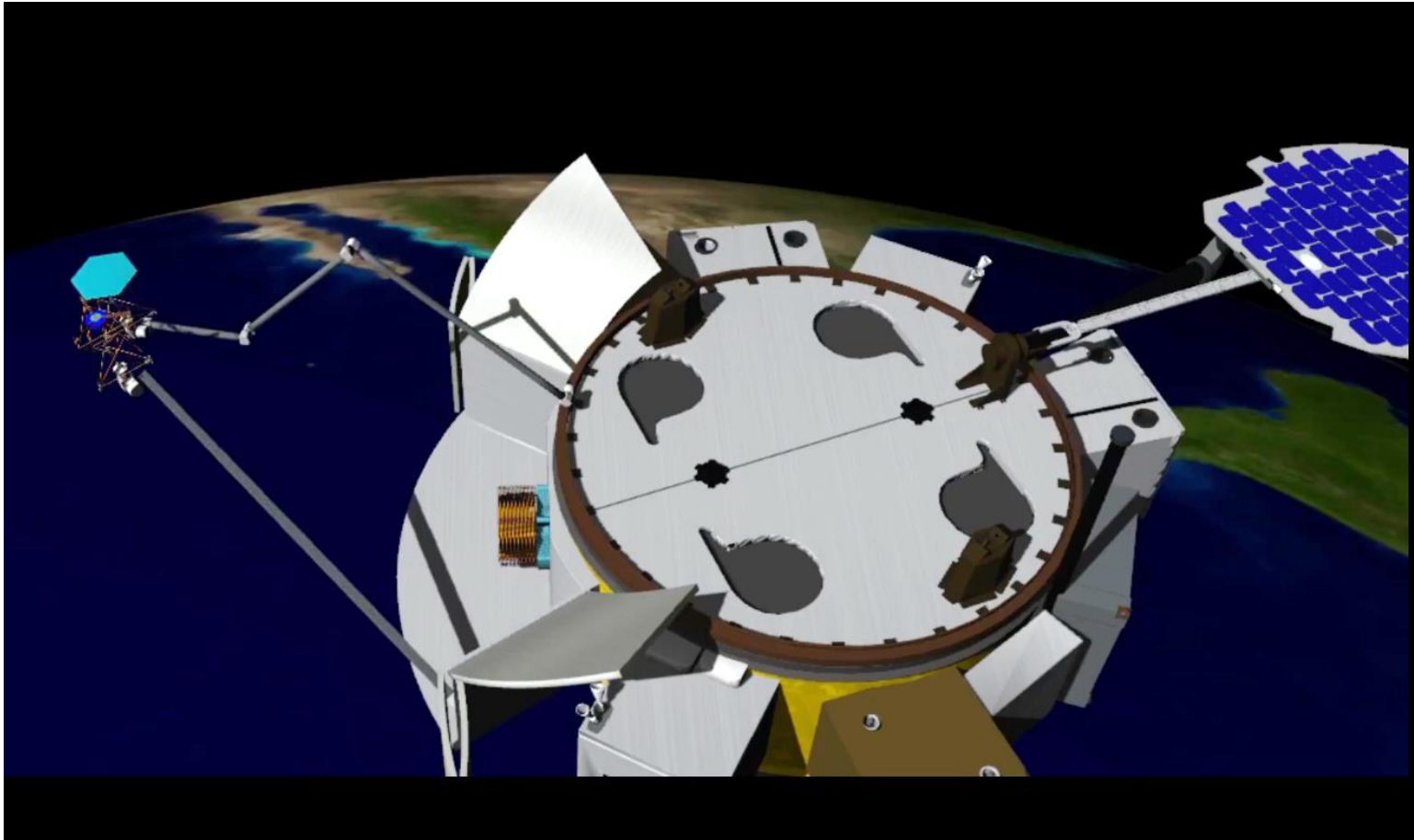

Benjamin N. Kelley,
John R. Cooper, Javier Puig Navarro,
Matthew P. Vaughan, Walter J. Waltz,
B. Danette Allen, and William R. Doggett
*NASA Langley Research Center, Hampton,
VA, 23681, USA*

Thea V. Avila, A. Kyle McQuarry,
Andrew Miloslavsky, Sherif A. Shazly,
Robert M. Slick, and Ralph A. Williams
*Analytical Mechanics Associates Inc.,
Hampton, VA, 23666, USA*

AIAA SciTech, January 2022

