



# Development and Ground Demonstration of a Satellite Communication Terminal for Future Space Missions



Marie Piasecki  
NASA Glenn Research Center  
Jan 18, 2022

# Contents



- Mission Communication Support at NASA
- Advancements in Commercial Satellite Communications
- Networks of the future
- Terminal Specifications and Approach
- Ground Demonstration
  - Terminal
  - Networks
  - ConOps
- Demonstration Results
  - Link Performance
  - Network Performance
  - Variable Coding and Modulation
  - Doppler
  - Roaming
- Conclusions
- Future Work





# What is SCaN?



## Enabling Human Space Exploration and Science Missions



Space Communications and Navigation (SCaN)  
**Serves as the Program Office for all of NASA's space communications activities**



**24/7** Global Near Earth and Deep Space Communications and Navigation Services



**100+** Missions currently Supported by SCaN



Develop, operate and manage all NASA space communications capabilities



Develop technologies to enable and enhance future mission experience

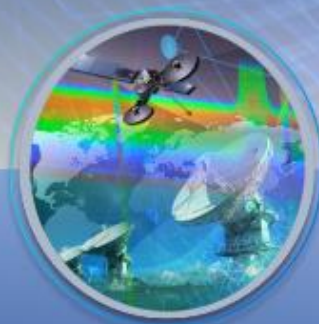

Manage NASA spectrum; represent NASA on national and international spectrum management forums



Develop space communication standards as well as positioning, navigation, and timing policies



Represent and negotiate on behalf of NASA on all matters related to space communications

# A Look at SCaN Near Space Network

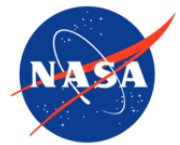

- Ten geosynchronous Tracking and Data Relay Satellites (TDRS)
- Three ground stations that relay data from missions in Earth orbit and launch vehicles
- Ground station/ antenna assets supporting missions close to the Earth



# Commercial SATCOM (COMSATCOM)



## SATCOM Frequency Allocations

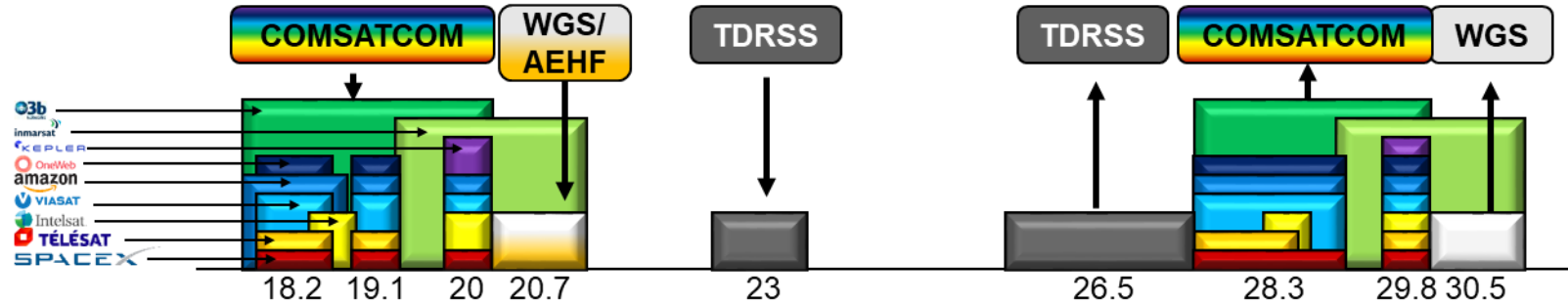

## Commercial SATCOM Evolution

1980s

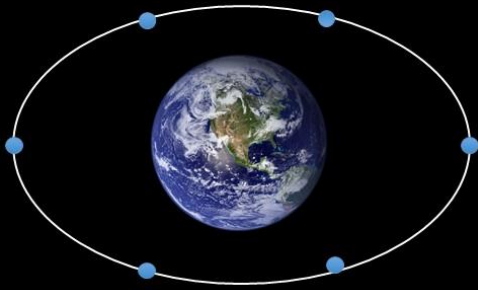

6 Key Commercial Satellites  
Around 200 Transponders

Today



Roughly 500 Commercial Satellites  
Around 6,000 Transponders

- Dozens of SATCOM providers
- Service available from GEO/MEO/LEO orbits
- High throughput bi-directional links offering near continuous coverage
- Predicted continued growth over the next 10 years\*
- Continued network investment from providers

\*The global satellite communication (SATCOM) market is projected to grow from \$25.33 billion in 2021 to \$46.50 billion in 2028  
<https://www.fortunebusinessinsights.com/satellite-communication-satcom-market-102679>

# Plan for Commercial Communications Services



*“Divide and Conquer” approach is tailored to market capabilities and risks...*

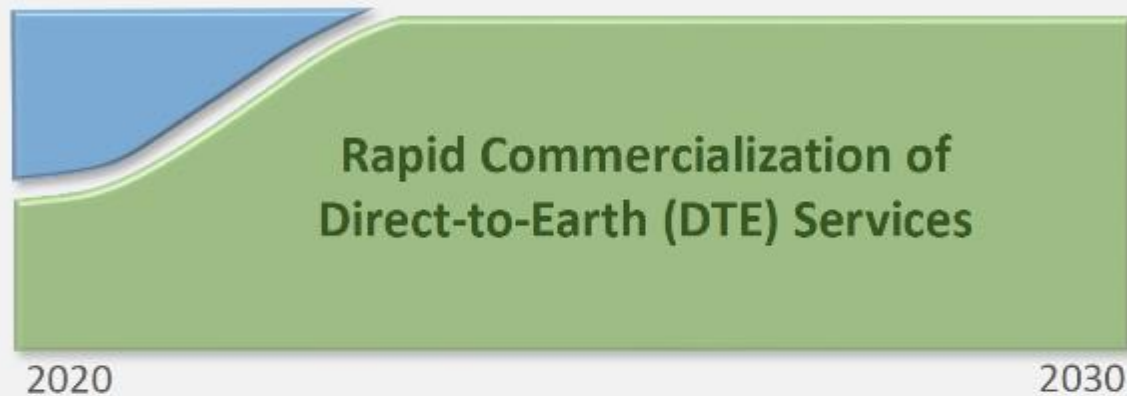

- Near-term increase in services provisioned by current commercial & partner ground sites
- Infuse new vendors drawing on vibrant and growing market
- Targeting 2023 for 100% commercial service; applies to existing and new missions



- NASA will no longer build/deploy Tracking and Data Relay Satellites
- Time required to gradually transition future NASA users
- New commercial capability used only for new missions; legacy missions fly out on the Space Network

NASA-owned service capability  
 Commercially-provided

# Vision to Leverage COMSATCOM

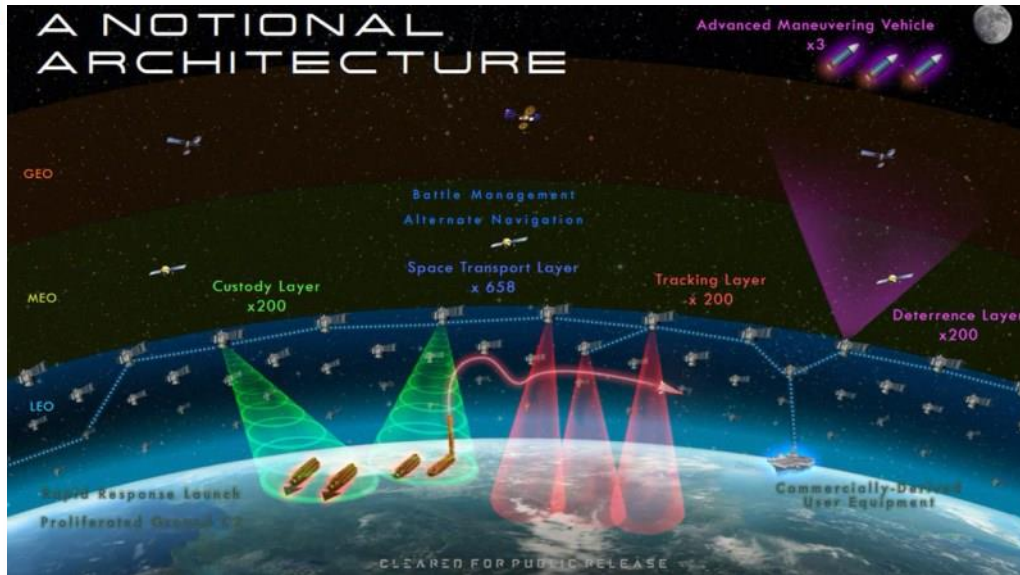

SDA Vision for Future SATCOM Architecture

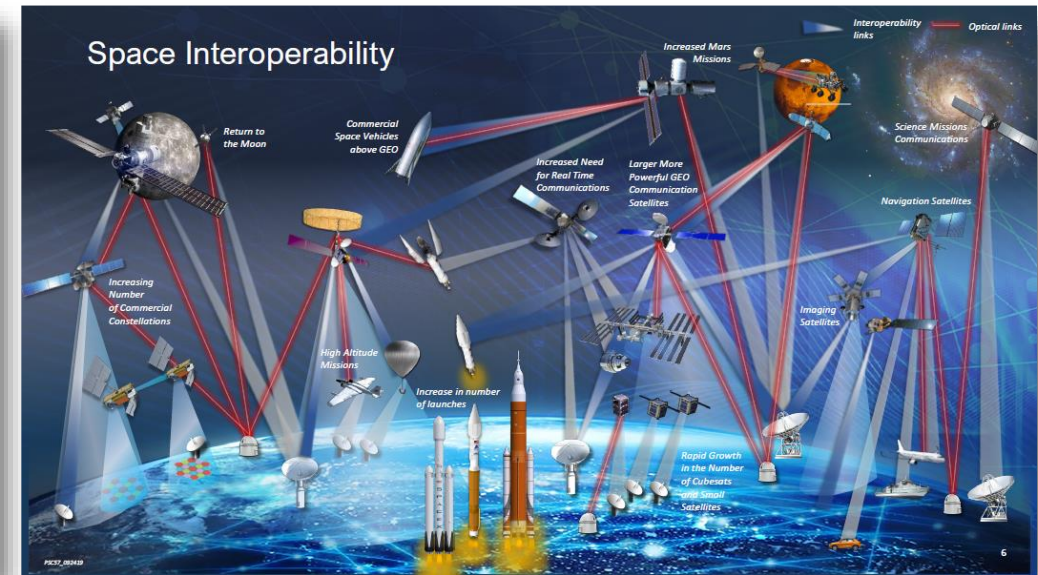

NASA Vision for Future SATCOM Architecture

- Future envisioned SATCOM architecture is complicated and disaggregated
  - Geosynchronous Orbit (GSO), Medium Earth Orbit (MEO), and Low Earth Orbit (LEO) constellations
  - DoD, NASA, International, and Commercial networks
- Space-based assets operating in this new framework require a flexible, low Size, Weight, and Power (SWaP) solution to be feasible
- SATCOM systems/technology must address:
  - Rapid, resilient, sustainable, and global access to SATCOM
  - Terminal and Network agility

# Wideband User Terminal

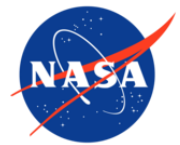

- Challenge: SATCOM currently operates with 130+ different user terminal architectures accessing disaggregated services across government, international, and commercial networks
  - No simplified solutions for space users
  - Interoperability challenges
- Approach: Develop a flexible user terminal to improve communications for future space missions
  - NASA/Military/Commercial Relays
  - Relay located in MEO/GEO/LEO Orbits
  - Mitigate 'Vendor' Lock
  - Reduce risk for mission utilization of commercial services

Terminal Specs	
Frequency Bands	17.7 – 23.55 GHz Receive 25.25 – 31.0 GHz Transmit
Bandwidth	>500 MHz (Tx and Rx)
Antenna	<1m class
Axial Ratio	1 dB Axial Ratio (Tx) 1.5 dB Axial Ratio (Rx)
Polarization	LHCP / RHCP
PA Output Power	10-20 W (SSPA)
EIRP	>50 dBW
G/T	>12 dB/K
Power	<200 W (Active)
Mass	< 15 kg
Temperature	-25 C to +55 C operational
Life	15 year
Radiation	100 kRad
EMC	MIL-STD-461F

# Ground Terminal Design



System Block Diagram

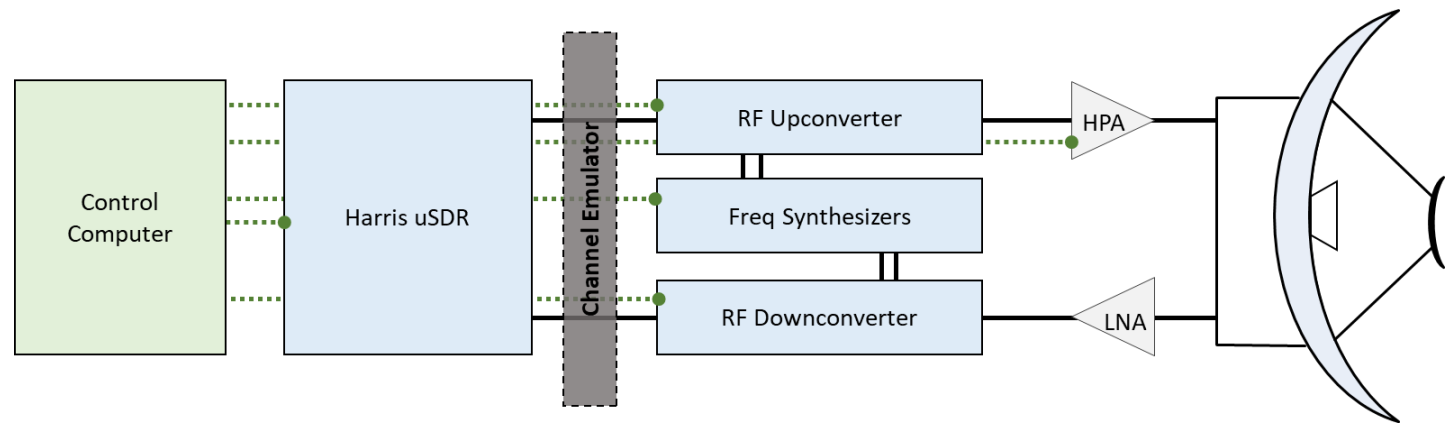

Up Converter Design

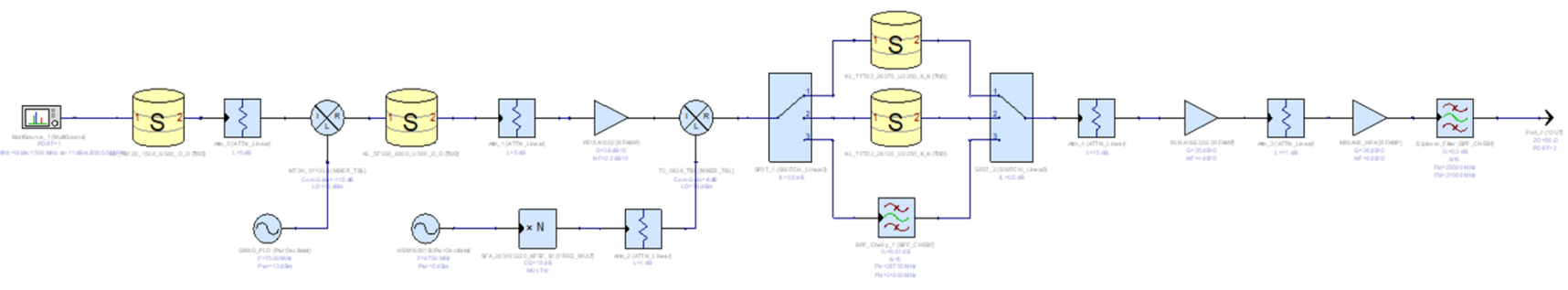

Down Converter Design

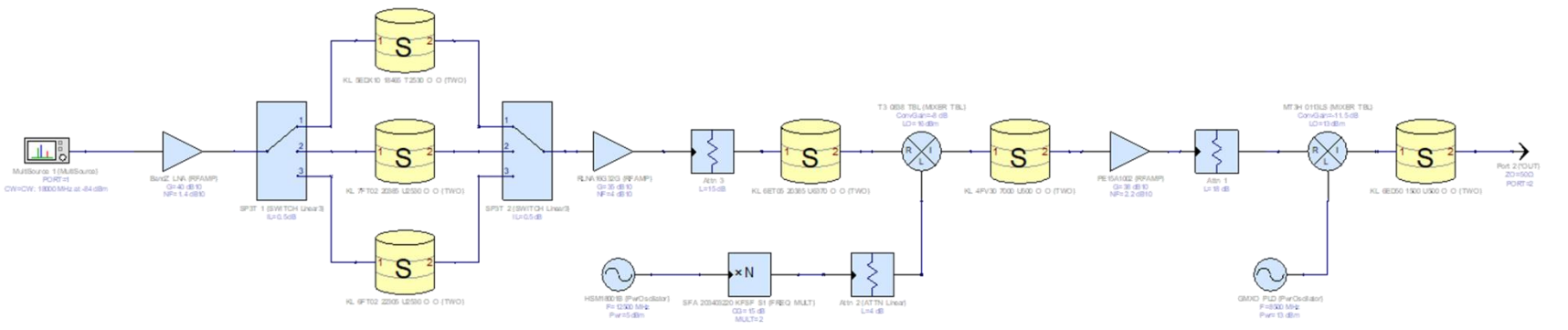

# Benchtop Testing

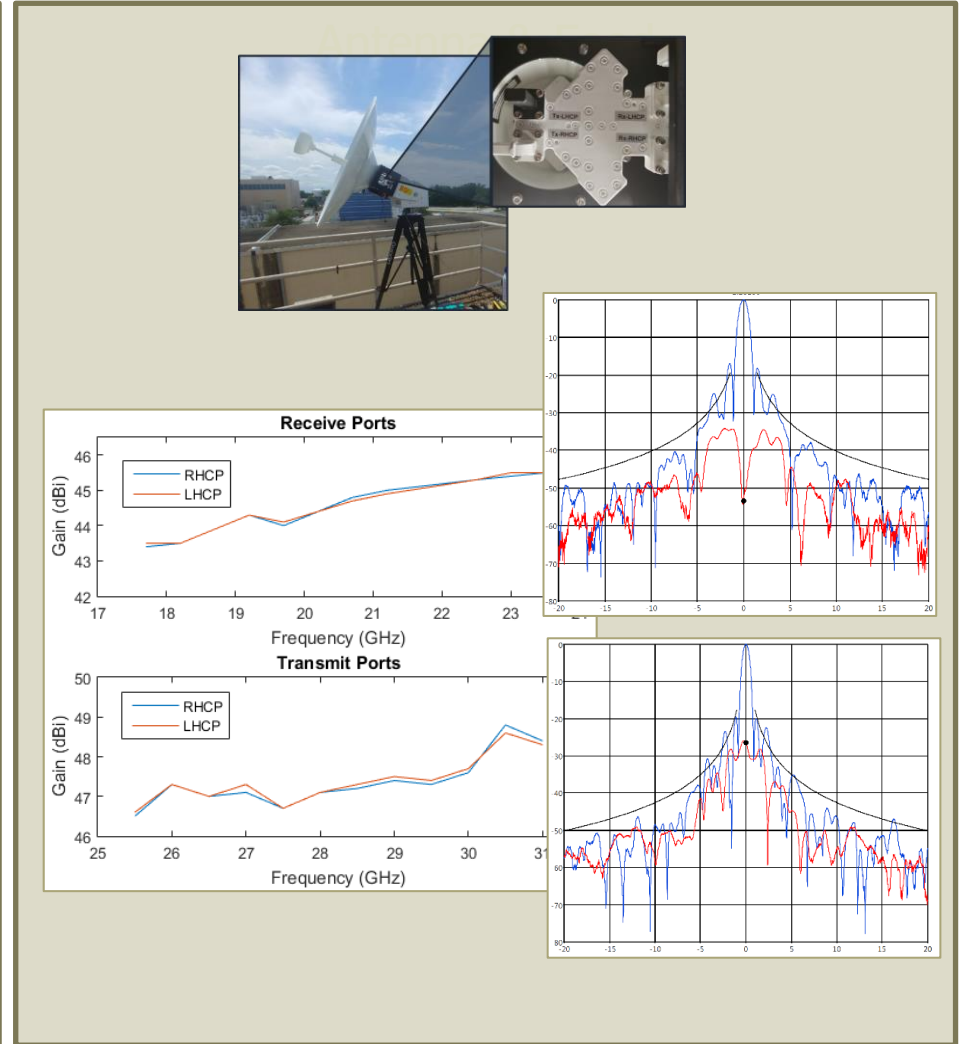
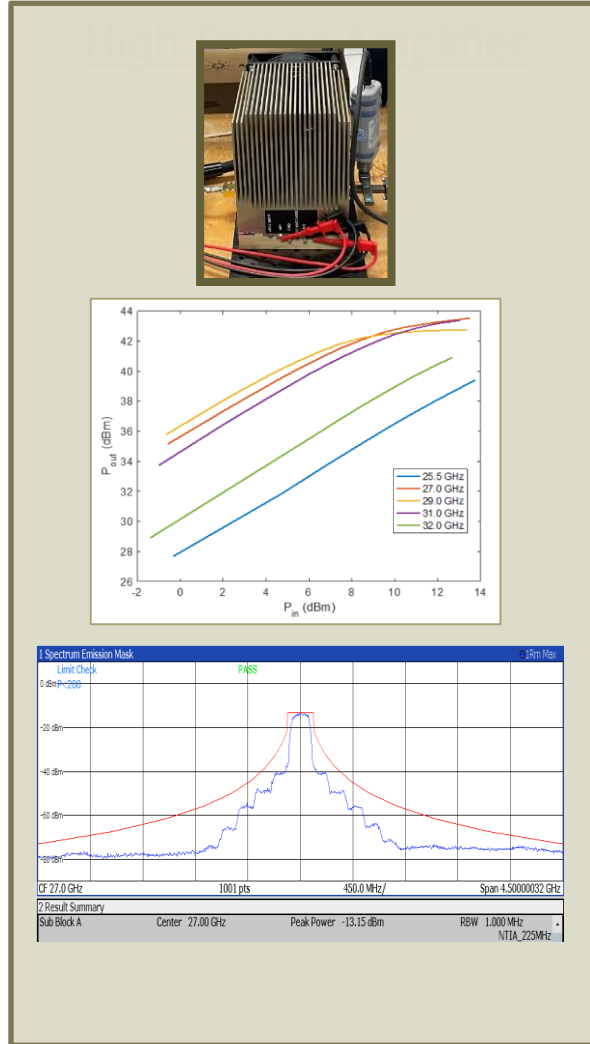
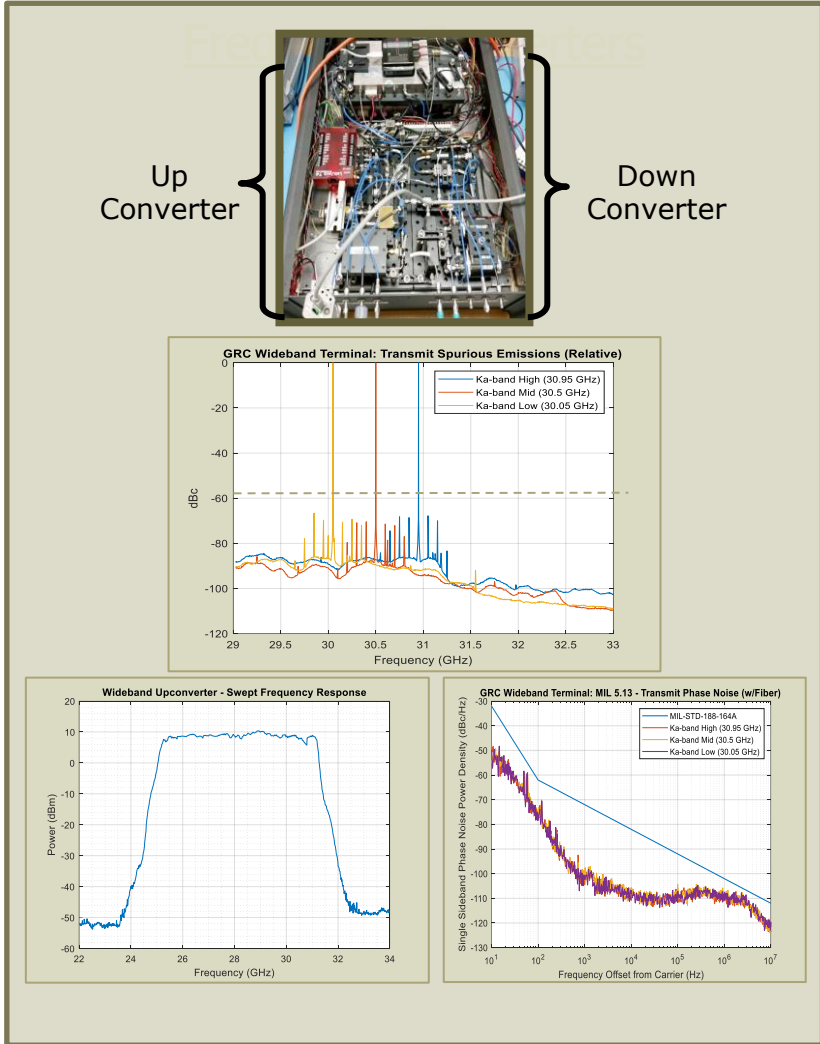

# Waveform Summary



## High-Rate Bandwidth-Efficient Transmit Waveform

**Modulation:** GMSK, BPSK, OQPSK, 4/8/16-PSK, 16-QAM, 16/32-APSK  
**Data Rate:** Tunable up-to 1.67 Gbps (un-coded), 333.33 Mbaud  
**Pulse-shape Filtering:** SRRC, RC  
**Forward Error Correction:** LDPC 1/2, 2/3, 4/5, 7/8, Rate 1/2 Conv  
**Digital Pre-distortion:** Memory-less, Symbol Pre-distortion  
**Channel Pre-compensation:** 32-tap FIR

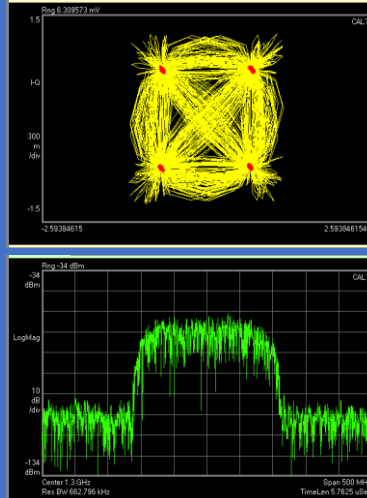

## DVB-S2 Transmitter

**Modulation:** 4/8-PSK, 16/32-APSK  
**Data Rate:** Tunable up-to 16 Mbaud (66.5 Mbps)  
**Pulse-shape Filtering:** SRRC 0.2, 0.35  
**Forward Error Correction:** LDPC 1/4 to 8/9, Short Frames  
**Pilots:** On or Off  
**Encapsulation:** ~Generic Stream Encapsulation (GSE)-Lite  
**Digital Pre-distortion:** Memory-less, Symbol Pre-distortion  
**Channel Pre-compensation:** 32-tap FIR

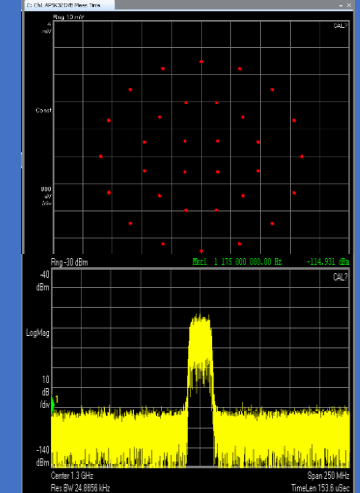

## PSK Receiver

**Modulation:** BPSK / QPSK  
**Data Rate:** Tunable up-to 7.5 Mbps, extensible to 62.5 Mbps  
**Forward Error Correction:** Viterbi, Rate 1/2 convolutional code  
**Framing:** CCSDS AOS

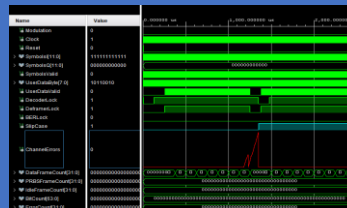
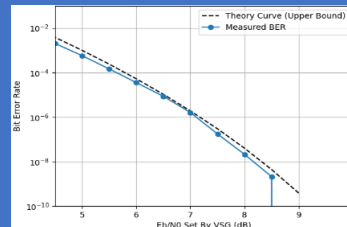

## DVB-S2/S2X Receiver

**Modulation:** 4/8-PSK, 16/32/64/128/256-APSK  
**Data Rate:** Tunable up-to 62 Mbaud (~250 Mbps)  
**Pulse-shape Filtering:** SRRC 0.05 ->, 0.35  
**Forward Error Correction:** LDPC 1/4 to 9/10, Short or Normal Frames  
**Pilots:** On or Off

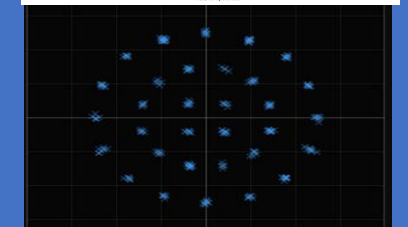
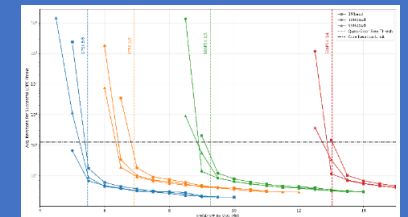

# Wideband User Terminal

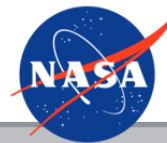

## Ground Demo System

	Desired	Ground Demo
FrequencyBands	17.7 – 23.55 GHz Receive 25.25 – 31.0 GHz Transmit	17.7 – 23.55 GHz Receive 25.25 – 31.0 GHz Transmit *HPA 27GHz – 31GHz
Bandwidth	>500 MHz (Tx and Rx)	500 MHz & 100 MHz (Switched)
Antenna	<1m class	1m Parabolic Dish
Axial Ratio	1 dB AxialRatio (Tx) 1.5 dB Axial Radio (Rx)	1 dB AxialRatio (Tx) 1.2 dB Axial Radio (Rx)
Polarization	LHCP / RHCP	LHCP / RHCP *LHCP for TX/RX *RHCP for RX beacons
PA Output Power	10-20 W (SSPA)	HPA capable of 30W
EIRP	>50 dBW	Typical Operation @55dBW
G/T	>12 dB/K	20 dB/K
Waveforms	SN and DVB-S2	HRBE (SN) and DVB-S2
Tracking	GEO/MEO/LEO	GEO/MEO/LEO *GEO/MEO Demonstrated

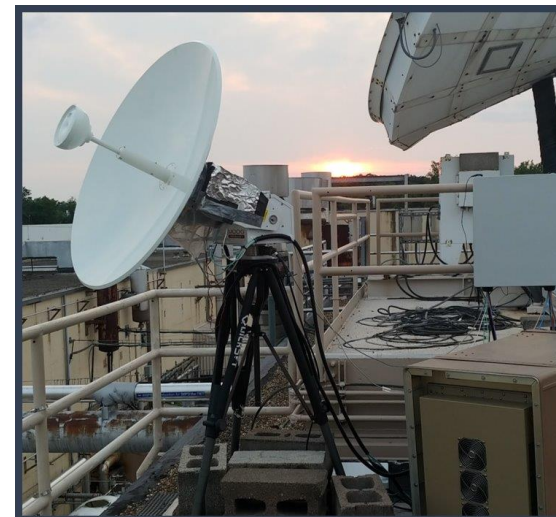

Antenna and RF Front End



High Power Amplifier (HPA)

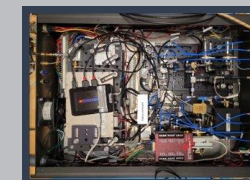

Up/Down Converter

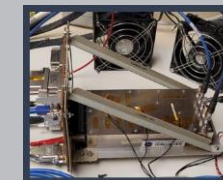

Software Defined Radio (SDR)

# Network Overview

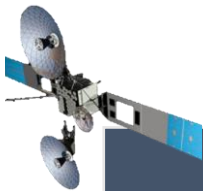

## TDRSS

- TDRS Generation 2&3
- Frequency
  - Forward: 22.5 GHz – 23.5 GHz
  - Return: 25.25 GHz – 27.5 GHz
- Geosynchronous Orbit
- SNUG and DVB-S2 Waveforms
- Bandwidth
  - Forward: 50 MHz
  - Return: 225/650 MHz



## Inmarsat

- I-5 High Capacity Payload Steerable Beams
- Frequency (Gov GX)
  - Forward: 20.2 GHz – 21.2 GHz
  - Return: 30.0 GHz – 31.0 GHz
- Geosynchronous Orbit
- DVB-S2 Waveform
- Bandwidth
  - Forward: 740 MHz
  - Return: 740 MHz

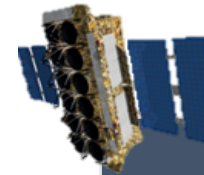

## O3b

- MEO Constellation
- Frequency
  - Forward: 17.79 GHz – 19.16 GHz
  - Return: 27.76 GHz – 28.96 GHz
- Medium Earth Orbit
- DVB-S2 Waveform
- Bandwidth
  - Forward: 216 MHz
  - Return: 216 MHz

# Ground Demonstration ConOps



## Service Provisioning

### *Commercial Services*

- Schedule Service & move beam to location
- TDRSS*
- Scheduled TUT time

## RF Path

### *Commercial Services*

- Establish bi-directional over the air path with each provider using DVB-S2

### *TDRSS*

- Standard SNUG Services or DVB-S2

## Network Interface

### *Commercial Services*

- Establish bi-directional terrestrial data path with each provider over the internet

### *TDRSS*

- Bi-directional data path through closed NISN IO Network

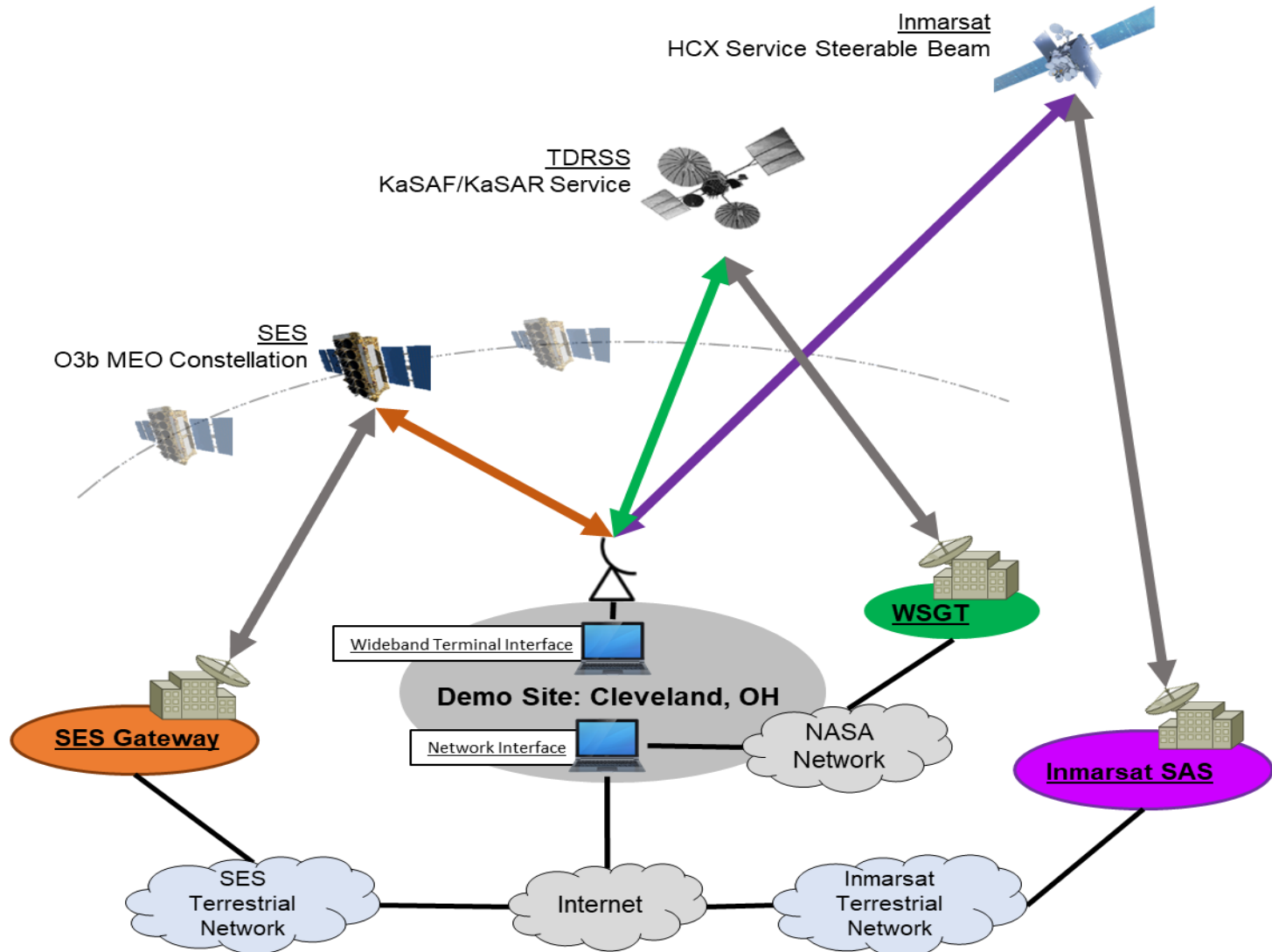



# Link Performance

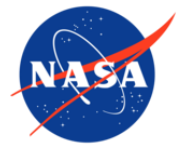

## Return Link Performance

	Modulation	FEC	Symbol Rate	Information Rate (Mbps)
TDRSS	OQPSK	Rate 1/2	150M	150
TDRSS w/DVB-S2	8-PSK	LDPC 9/10	200M	535.8
Inmarsat	8-PSK	LDPC 3/5	70M	124.6
Inmarsat	16-APSK	LDPC 3/4	15M	41.42
O3b	8-PSK	LDPC 3/4	70M	145.45
O3b	32-APSK	LDPC 8/9	20M	83.2



## Forward Link Performance

	Modulation	FEC	Symbol Rate	Information Rate (Mbps)
Inmarsat	8-PSK	LDPC 5/6	59M	146
O3b	16-APSK	LDPC 2/3	80M	200.4

# Additional Demonstration Results



- Network Connectivity
  - Internet Control Message Protocol (ICMP) Ping Tests
  - UDP Data Tests
- Variable Coding and Modulation
  - All DVB-S2 MODCODs demonstrated
  - Tests included +/-700 kHz Doppler at 1.1 kHz/sec
- Doppler Emulation
  - Doppler tests run at 15 MBaud with 16-APSK LDPC 3/4 modulation
- Roaming
  - Successfully demonstrated service roaming between TDRSS and commercial vendors with <30 sec downtime

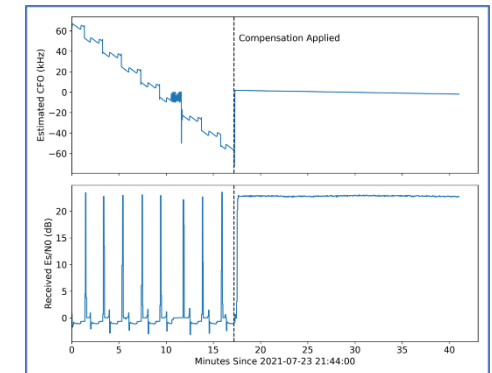
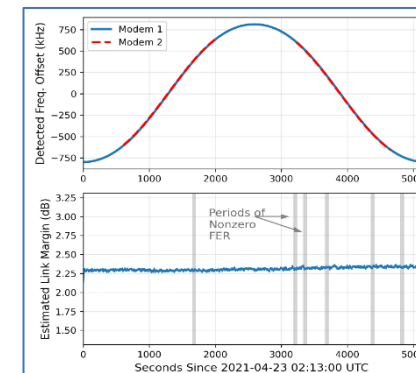
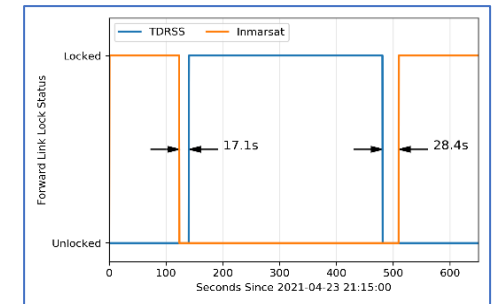
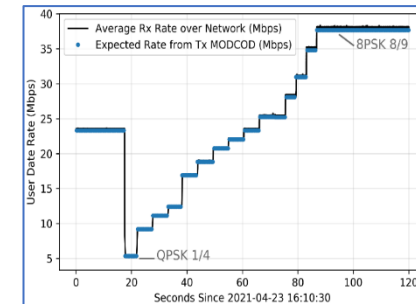
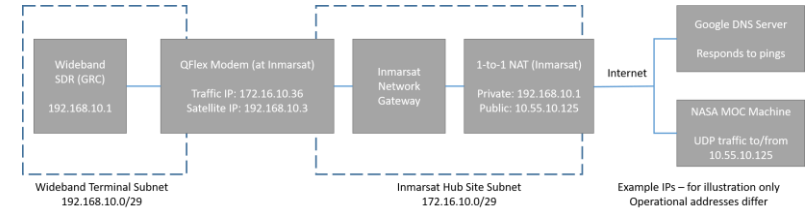

# Roaming Demonstration

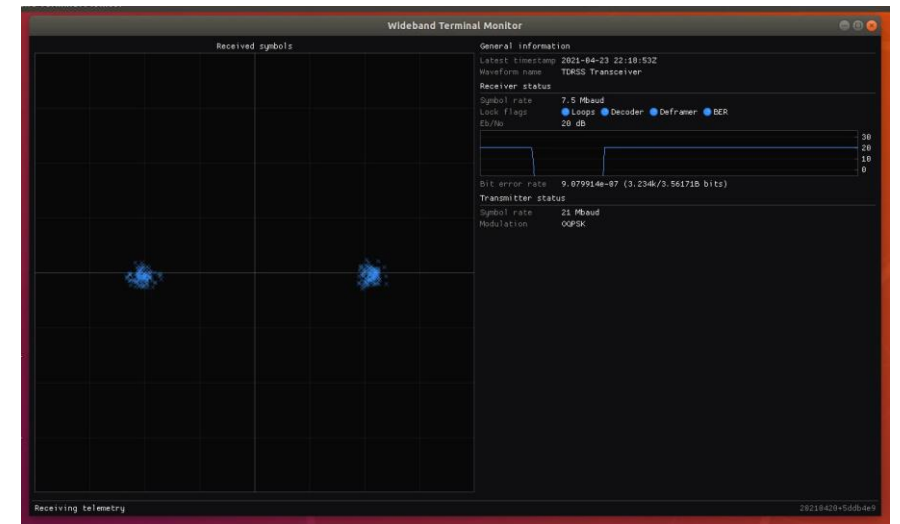
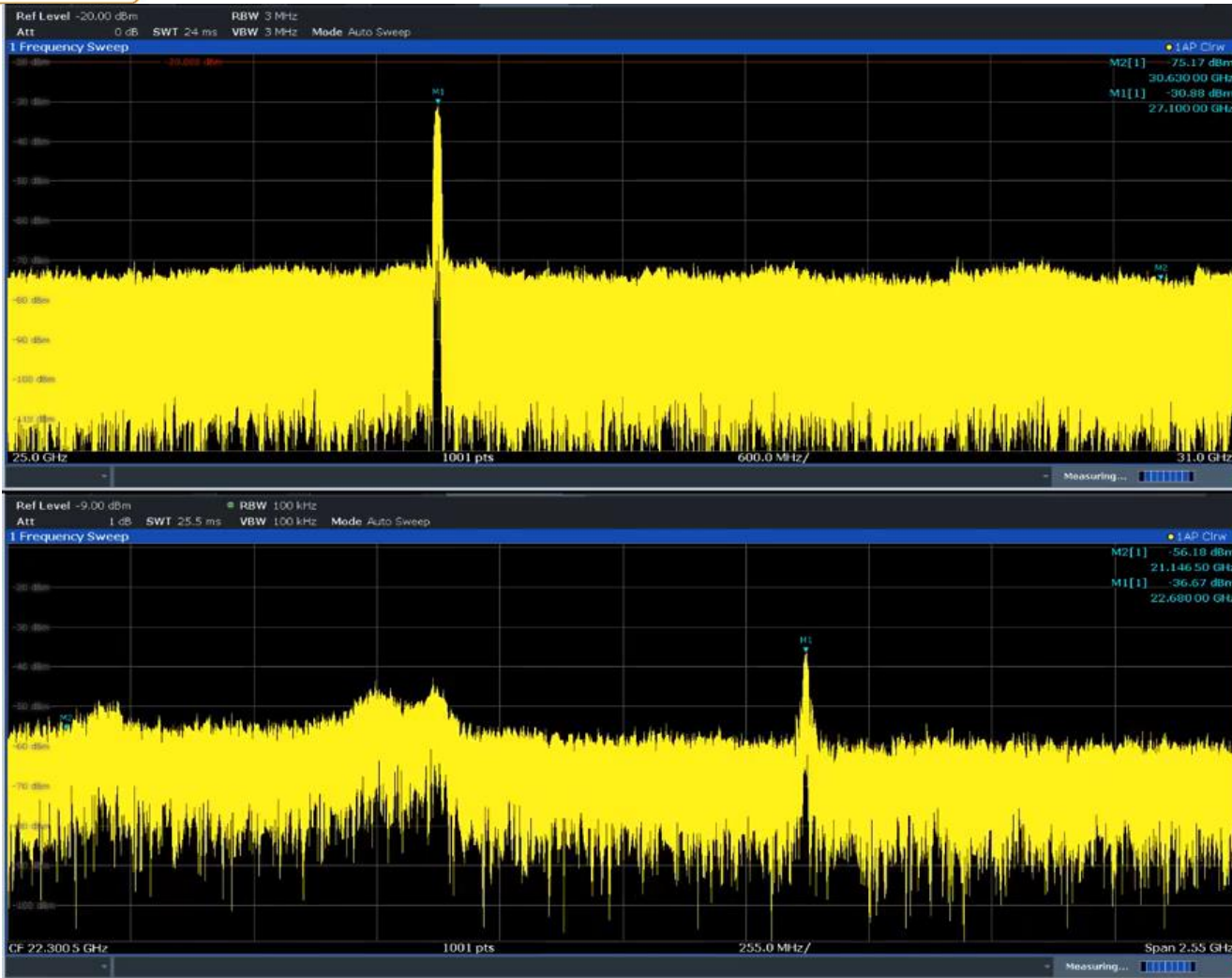



# Conclusions



- Single terminal can support multiple networks with different topologies
  - Spectrum Coverage
  - Tracking both MEO and GEO
  - Comparable data rates across vendors
- Roaming between networks demonstrated
- Tunability allows for flexibility in congested environments
- Some differences found when operating on different networks
  - Networks need to be evaluated for compatibility before mission use
  - Operational differences both procedural and technical

# Flight Terminal Development

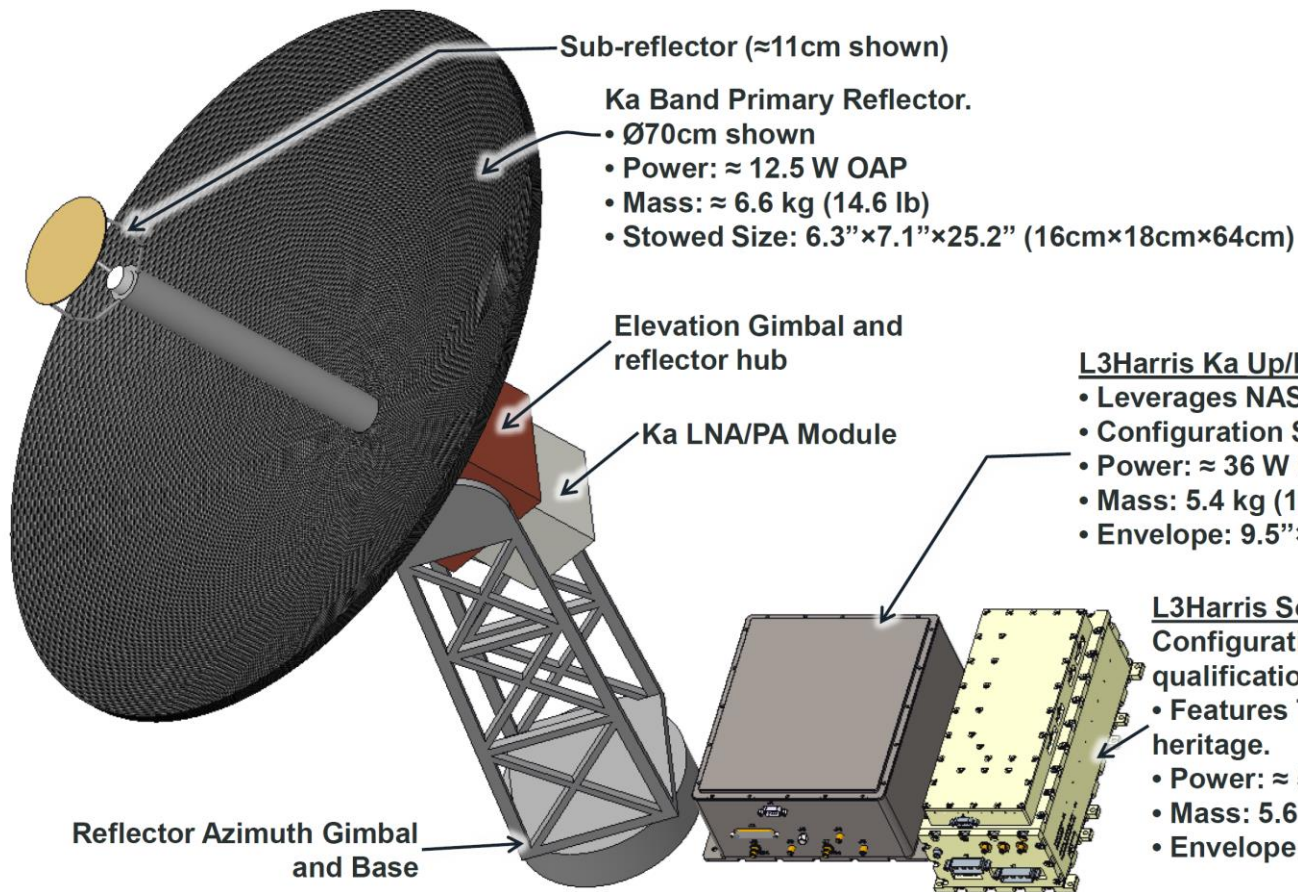

## Flight Amplifier Development

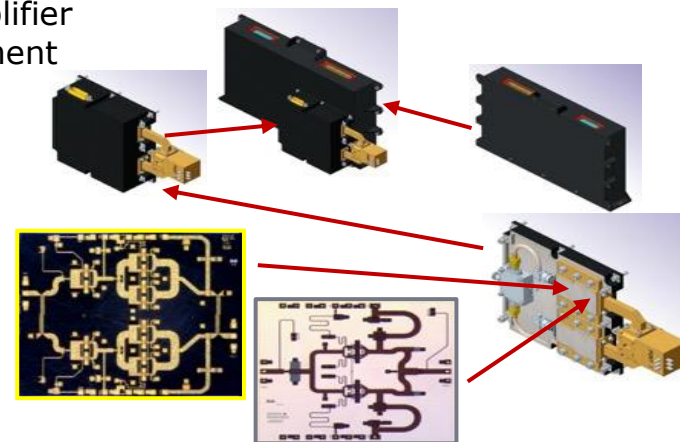

### L3Harris Ka Up/Down Converter Assembly (KaUDCA)

- Leverages NASA CoNNeCT Architecture
- Configuration Shown developed to PDR Level in 2017
- Power: ≈ 36 W OAP
- Mass: 5.4 kg (11.9 lb)
- Envelope: 9.5"×9.0"×4.0" (24.1cm×22.9cm×10.2cm)

### L3Harris Software Defined Radio Assembly (SDRA)

- Configuration shown has completed Protoflight qualification and is Awaiting 2021 Launch.
- Features TRL-9 μSDR Module with significant on-orbit heritage.
  - Power: ≈ 50W OAP
  - Mass: 5.6 kg (12.3 lb)
  - Envelope: 5.0"×11.0"×4.5" (12.7cm×27.9cm×11.4cm)



# Future Work



- Vendor Waveforms
- Network/Enterprise Management
- Security Protections
- Position, Navigation, and Timing Applications
- Extending 5G for Space Users
- Electronically Steered Arrays
- Adaptive and Cognitive algorithms



# Thank You!

