

Development and Testing of a Minimum-Mass Unpressurized Crewed / Autonomous Rover

Moon to Mars Exploration Systems and
Habitat (M2M X-hab) 2021 Academic
Innovation Challenge

Final Report
University of Maryland

Dr. David L. Akin
August 31, 2021

UNIVERSITY OF
MARYLAND

**Space
Systems
Laboratory**

Summary Narrative

In April, 2020, the University of Maryland proposed to the NASA Moon to Mars 2021 Academic Innovation Challenge Program to design, fabricate, and test a lightweight lunar rover that could be beneficial to the Artemis human lunar exploration program. The concept proposed had grown out of prior University of Maryland involvement in EVA support rovers, including extensive analog field testing of a previous rover design. The paradigm adopted was to design a pair of single-person rovers instead of a two-person vehicle such as the Apollo Lunar Roving Vehicle. Although designed for one astronaut nominally, each rover would be capable of carrying two astronauts in a contingency. Analysis showed that this approach provided greater astronaut safety than a single vehicle, and greatly reduced the necessary adherence to the “walkback” criteria which states that the EVA crew must always have sufficient life support capability to walk back at any point in the surface traverse. The second key point in the paradigm was that both rovers must be light enough to be transported together on a single Commercial Lunar Payload Services (CLPS) lander to the surface. Since (at the time of proposal) no decision had been made yet on the Artemis Human Lander System, it was felt that pre-deployment of the rovers would be the least (programmatically) risky approach to ensuring that they could be available for early Artemis lunar missions. This limited the allowable mass for each rover to approximately 250 kg, based on the largest announced CLPS lander concept of the time.

The University of Maryland (UMd) plan consisted of focusing X-Hab activities in the Fall 2020 term on student projects in ENAE 100 (Introduction to Aerospace Engineering) and ENAE 788X (Planetary Surface Robotics). ENAE 100 teams have been integral parts of many UMD X-Hab programs in the past, usually focusing on small-scale proof-of-concept studies or focusing on alternative approaches to the main activities. The graduate students in ENAE 788X would divide into small teams to perform a detailed design study on the rovers, using the advanced algorithms taught in the class such as terramechanics analysis for modeling

wheel-soil interactions. The multiple designs documented at the end of the Fall term would form the basis of the Spring 2021 activities, which would start with synthesis of a single baseline design based on the best ideas of the multiple graduate projects, which would then enter fabrication and testing.

It was unknown at the time of proposal what the status of the university would be due to the COVID-19 pandemic. The University of Maryland had gone on 100% remote instruction in early March 2020, which interfered with the 2020 UMd X-Hab project. As it turns out, UMd stayed 100% remote throughout the 2020-2021 academic year. This meant that ENAE 100 did not do any team projects, eliminating that portion of the planned activities. While the remote instruction did not markedly hamper the analysis and design activities of the ENAE 788X teams, it was impractical to begin fabrication until almost the end of the Spring 2021 term, and it was not possible to complete the fabrication of the rover. However, most of the detailed design work was completed, and a team at the Space Systems Laboratory started the core fabrication process during the Summer of 2021.

This report documents the activities of the University of Maryland team on this X-Hab project. Beyond this brief narrative, the primary documentation is a paper on the rover design, published and presented at the 50th International Conference on Environmental Systems in July, 2021, appended here. Also appended are the final reports of the four ENAE 788X design teams, which were submitted in the form of presentation slides. The final attachment consists of the slides from the final X-Hab review presentation to NASA on July 29, 2021.

This activity would not have been possible without the enthusiastic support of NASA, as well as the hard work from all of the students involved at each phase of the program. I would like to acknowledge those students here:

SSL Graduate Students: Daniil Gribok, Charles Hanner, and Zachary Lachance

SSL Undergraduate Students: Nicolas Bolatto, Amelia Cherian, Robert Fink, Joshua Martin, and Tal Ullmann

ENAE 788X Team Protogonus: Pat Hoskins, Jaad Lepak, Joe Perrella, and Loy McGuire

ENAE 788X Team SCAMP: Charlie Hanner, Nicolas Bolatto, and Zach Lachance

ENAE 788X Team Courage: Justin Albrecht, Brian Bock, Prateek Bhargava, and Sayani Roy

ENAE 788X Team ROCI: Aalay Patel and James Winsley

Attachments:

ENAE 788X Final Report, Fall 2020: Courage

ENAE 788X Final Report, Fall 2020: Protogonus

ENAE 788X Final Report, Fall 2020: ROCI

ENAE 788X Final Report, Fall 2020: SCAMP

X-Hab 2021 Final Review, University of Maryland

ENAE788x COURAGE Rover

Justin Albrecht
Brian Bock
Prateek Bhargava
Sayani Roy

2

Overview

- Project Requirements
- Final Design (intro)
- Terramechanics
- Stability
- Steering
- Suspension
- Power
- Mass
- Final Design (detailed)
- Earth & Mars efficacy
- Trafficability
- Design Evolution and Concepts

3

Project Requirements

Project Description:

- Perform a detailed design of a BioBot rover, emphasizing mobility systems
 - Chassis systems (e.g., wheels, steering, suspension...)
 - Support systems (e.g., energy storage)
 - Navigation and guidance system (e.g., sensors, algorithms...)
- Design for Moon, then assess feasibility of systems for Mars, and conversion to Earth analogue rover

Requirements (Performance) :

1. Maximum operating speed of at least **4 m/sec** on level, flat terrain.
2. Accommodate a **0.3 meter** obstacle at minimal velocity.
3. Accommodate a **0.1 m** obstacle at a velocity of 2.5 m/sec.
4. Accommodate a **20° slope** in any direction at a speed of at least 1 m/sec and including the ability to start and stop.
5. A nominal sortie range of **54 km** at an average speed of **2.5 m/sec**.

4

Project Requirements

Requirements (Payload) :

1. Capable of carrying one 170 kg EVA crew and 80 kg of assorted payload
2. Payload may be modeled as a 0.25 m box
3. Capable of carrying a second 170 kg EVA crew in a contingency situation.
4. Incorporate roll-over protection for the crew and all required ingress/egress aids and crew restraints.

Requirements (Operations) :

1. A nominal sortie shall be at least eight hours long.
2. Two rovers must be launched on a single CLPS lander.
3. A single rover shall mass ≤ 250 kg.
4. Capable of operating indefinitely without crew present.

Requirements (GN&C) :

1. Capable of being controlled directly, remotely, or automated.
2. Capable of following an astronaut, astronaut's path, or autonomous path planning between waypoints.
3. Capable of operating during any portion of the lunar day/night cycle and at any latitude.

5

Courage Rover - Normal Use (Non Extended)

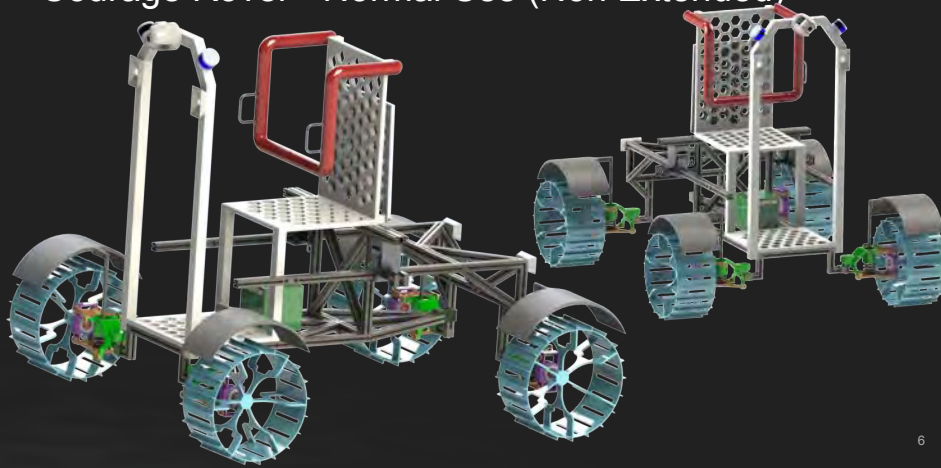

Courage Rover - Contingency Use (Extended)

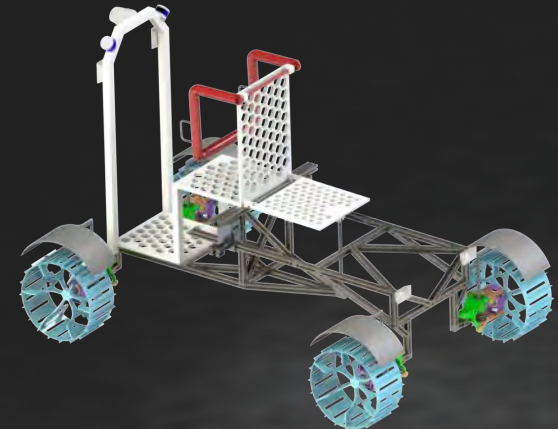

Terramechanics

Trade Study - Drawbar Pull - No Grousers - Flat Terrain

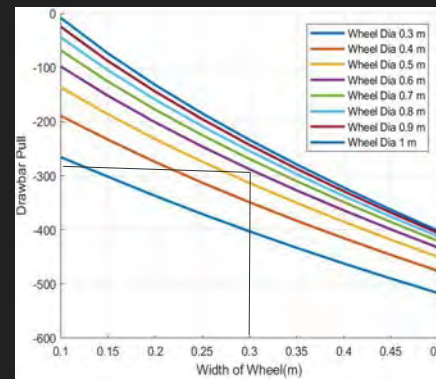

4 Wheels

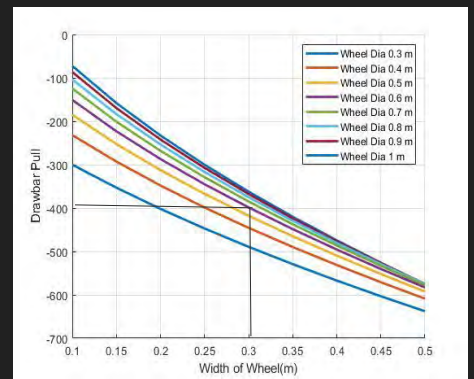

6 Wheels

Trade Study - Drawbar Pull - No Grousers - 20 Slope

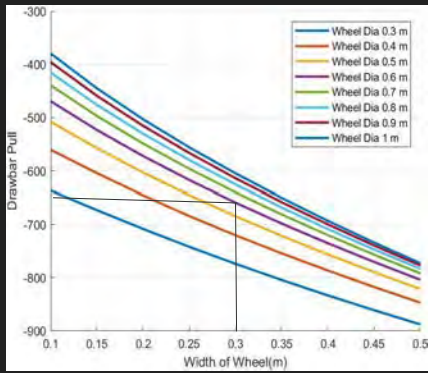

4 Wheels

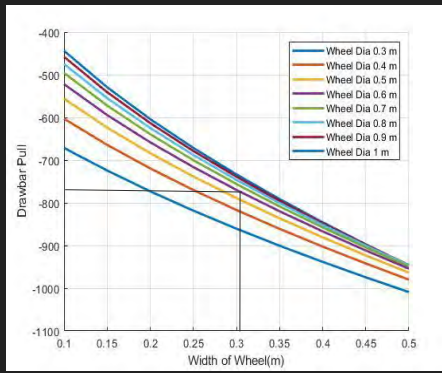

6 Wheels

10

Trade Study - Drawbar Pull - Grousers - Flat

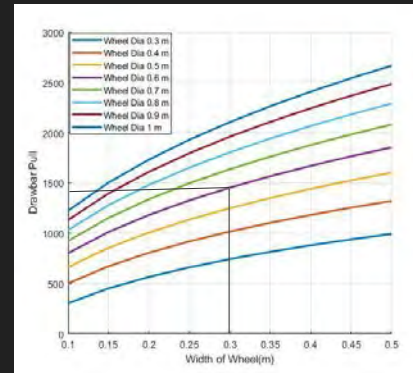

4 Wheels

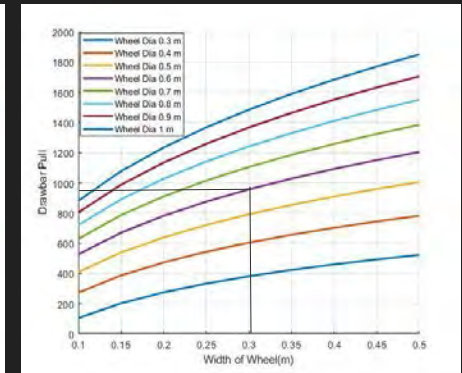

6 Wheels

11

Trade Study - Drawbar Pull - Grousers - 20 Slope

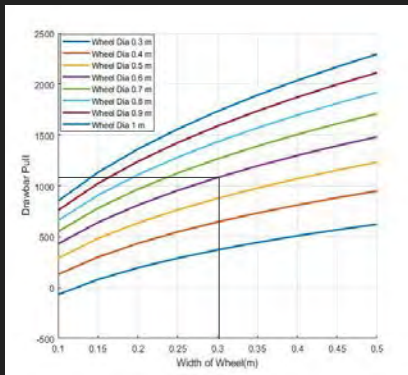

4 Wheels

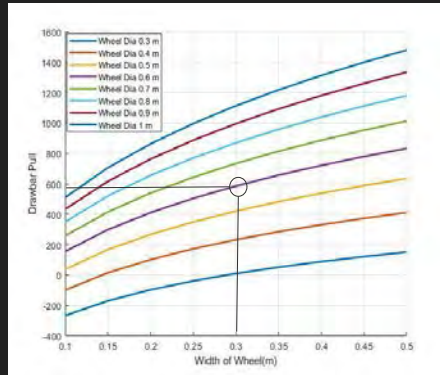

6 Wheels

12

Drawbar Pull 4 Wheels - No. of Grousers

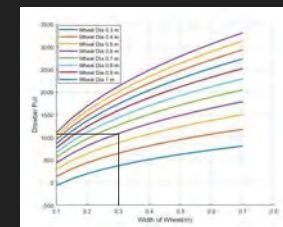

8

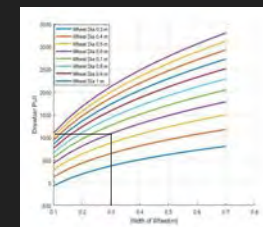

12

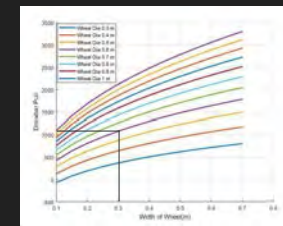

16

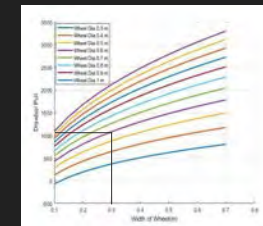

24

13

Drawbar Pull 4 Wheels - Height (cm)

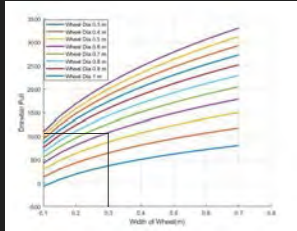

2 cm

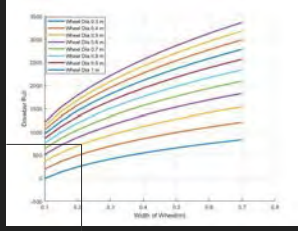

3 cm

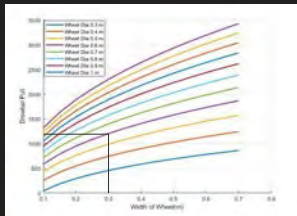

4 cm

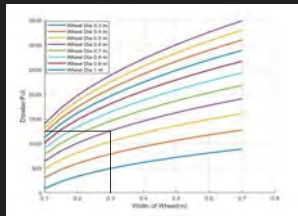

5 cm

Drawbar Pull 6 Wheels - No. of Grousers

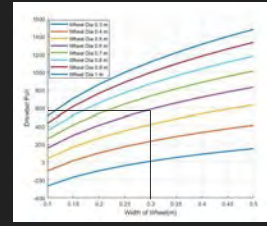

8

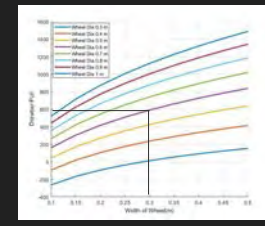

12

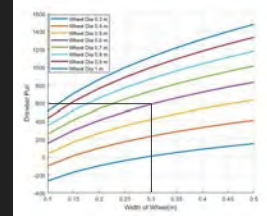

16

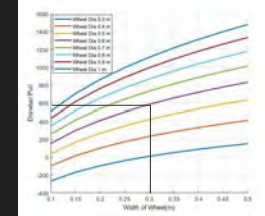

24

Drawbar Pull 6 Wheels - Height (cm)

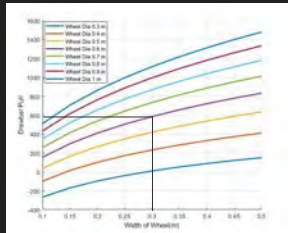

2 cm

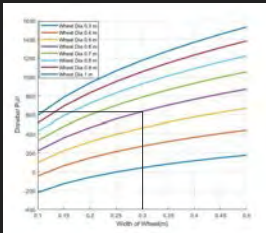

3 cm

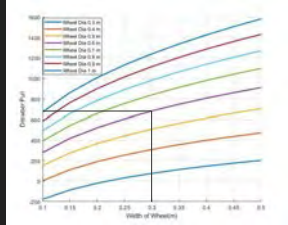

4 cm

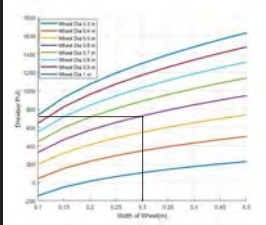

5 cm

Wheel Drawing

Wheel Dimensions	
Diameter	60 cm
Width	30 cm
Grouser Height	2 cm
Number Spokes	6

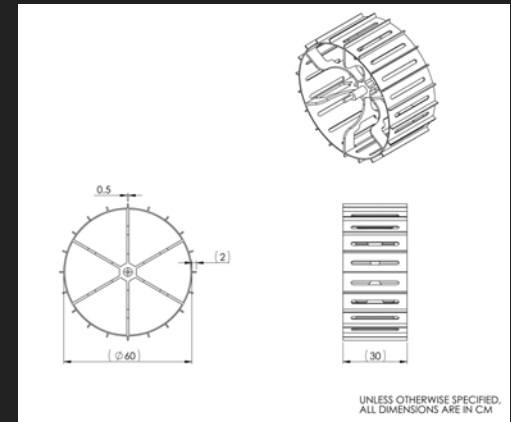

UNLESS OTHERWISE SPECIFIED, ALL DIMENSIONS ARE IN CM

Terramechanics : Design Solution

From the above trade studies performed between 4 Wheels and 6 Wheels for diameter, width of wheels against drawbar pull, number of grousers and height of grousers; we have chosen the following values:

1. Diameter of wheel(d) - 0.6 m
2. Width of wheel (w) - 0.3 m
3. Number of grousers - 20
4. Height of grousers - 0.02 m = 2 cm

18

Stability

19

Stability - Forces wrt h and l

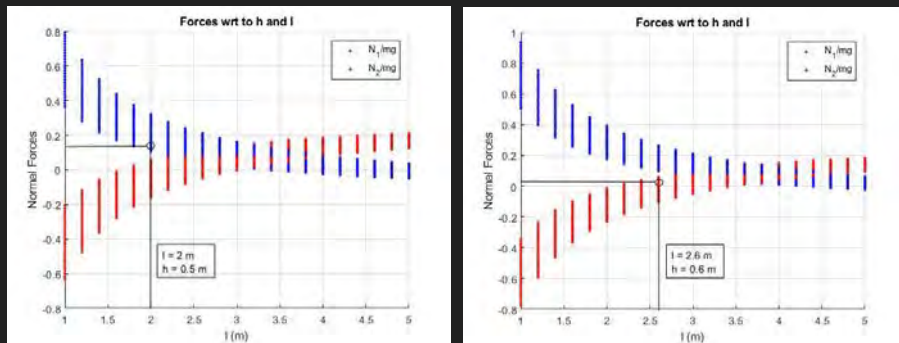

Non - Extended

Extended

20

Stability - Forces wrt h and a

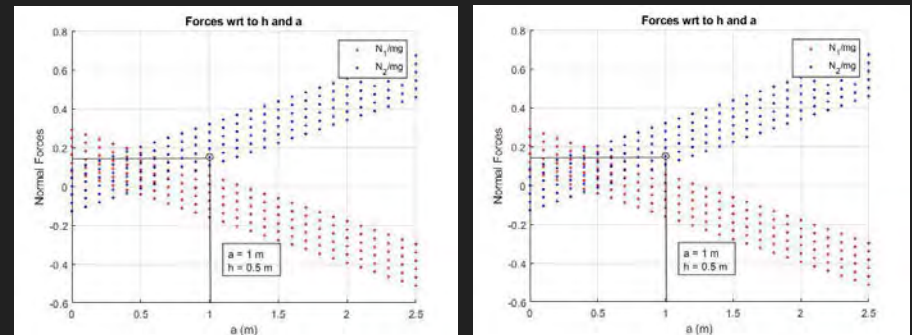

Non - Extended

Extended

21

Slope Stability - Uphill / Downhill

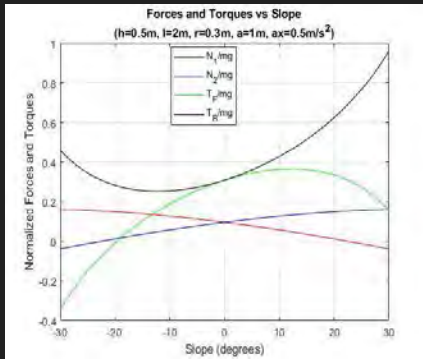

Non - Extended

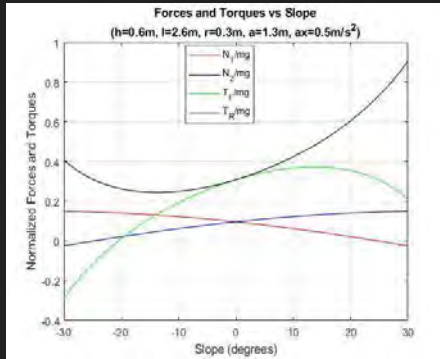

Extended

22

Acceleration Stability

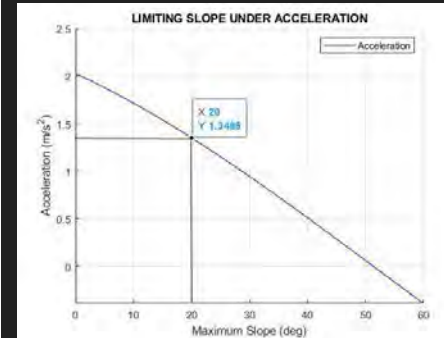

Non - Extended

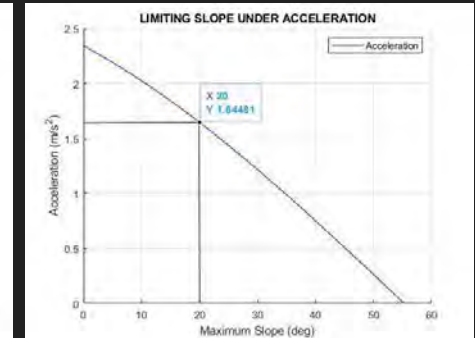

Extended

23

Deceleration Stability

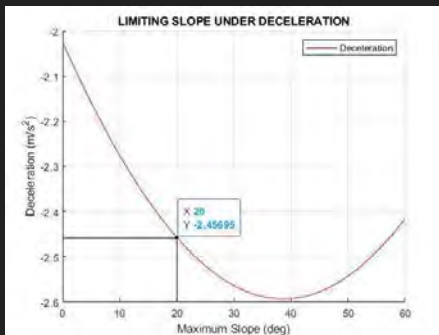

Non - Extended

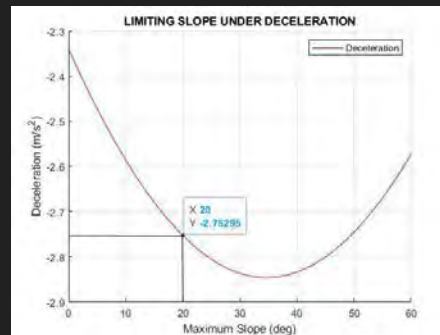

Extended

24

Stability - Design Solution

- Non Extended - When the rover has only one EVA crew with an overall design mass of 500 kg.
 - Length of rover (l) - 2 m
 - Width of rover (c) - 1.6 m
 - Height of CoM (h) - 0.5 m
 - Length between front axle and CoM (a) - 1 m
 - Max Acceleration Rate (m/s^2)
 - Flat Terrain - 2.025
 - Slope - 1.3488
 - Max Deceleration Rate (m/s^2)
 - Flat Terrain - 2.025
 - Slope - 2.45695

25

Stability - Design Solution

2. Extended - When the rover has one EVA crew and one emergency EVA crew, for a total design mass of 670 kg.

- Length of rover (l) - 2.6 m
- Width of rover (c) - 1.6 m
- Height of CoM (h) - 0.6 m
- Length between front axle and CoM (a) - 1.3 m
- Max Acceleration Rate (m/s^2)
 - Flat Terrain - 2.34
 - Slope - 1.6481
- Max Deceleration Rate (m/s^2)
 - Flat Terrain - 2.34
 - Slope - 2.75295

26

Turning Stability - 4 Wheels - Flat Terrain

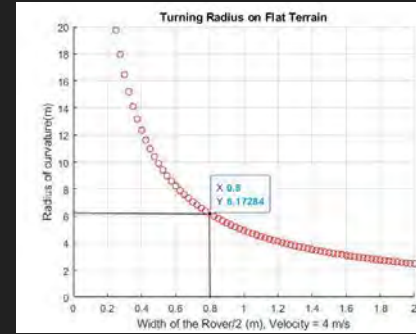

Non - Extended

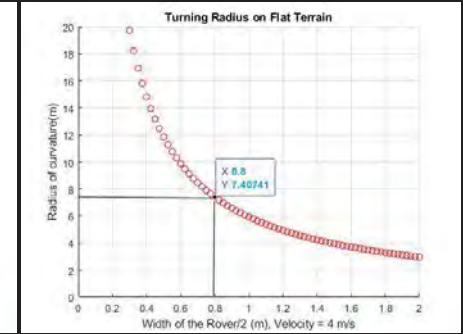

Extended

27

Turning Stability - 4 Wheels - Slope

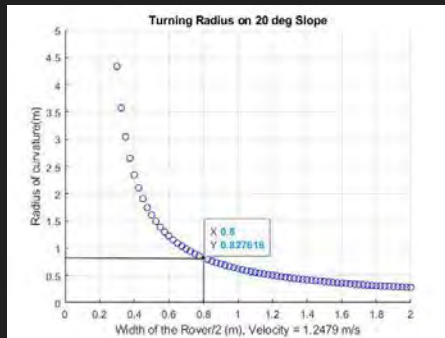

Non - Extended

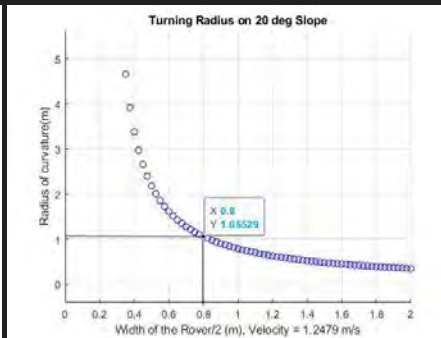

Extended

28

Steering

29

Steering Mechanism Design

Front two wheels are direct steered, each with a steering motor.

Rear wheels are fixed to the chassis

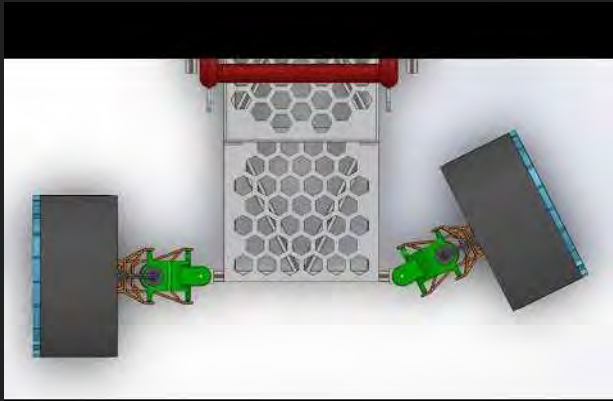

30

Steering Angle

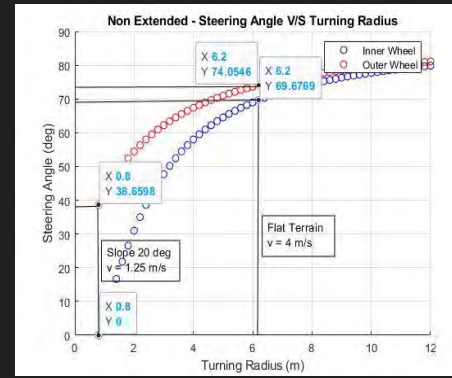

Non - Extended

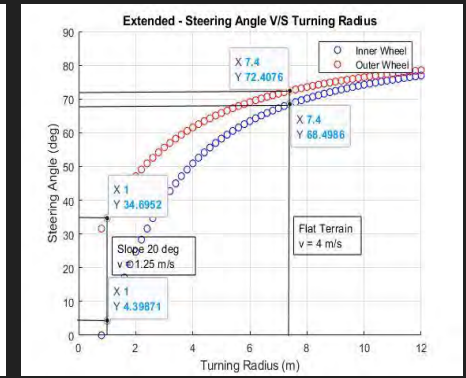

Extended

31

Suspension

32

Suspension System

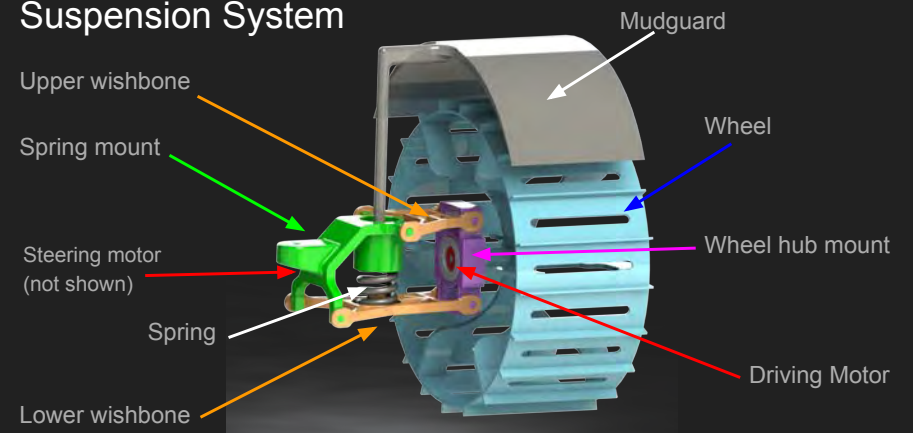

33

Suspension

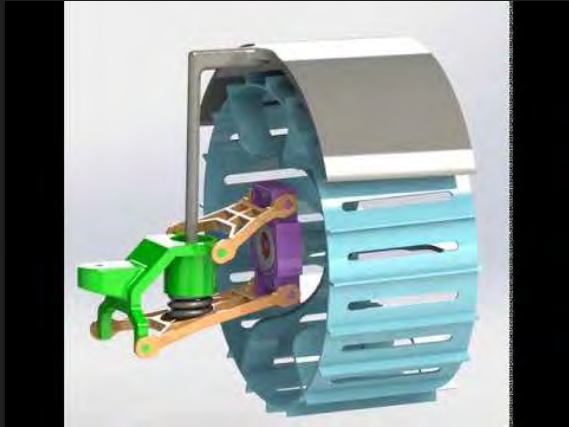

34

Suspension Statics

Using the method for N-wheeled independent suspension from class we can solve for weight distribution on each wheel including when wheels are on obstacles.

	Standard	Extended
COM Offset	$[X_{cg}]_v = \begin{bmatrix} 0.115 \\ 0 \\ 0.87 \\ 1 \end{bmatrix}$	$[X_{cg}]_v = \begin{bmatrix} -0.156 \\ 0 \\ 0.96 \\ 1 \end{bmatrix}$
Total Weight	682 N	957 N
Length	2 m	2.6 m
Width	1.6 m	1.6 m

35

Weight Distributions on Flat Terrain

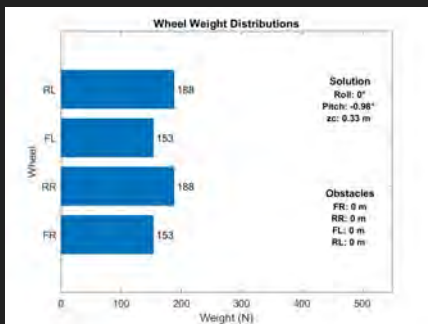

Standard Configuration



Extended Configuration

36

Weight Distributions (Front Right on Obstacle)

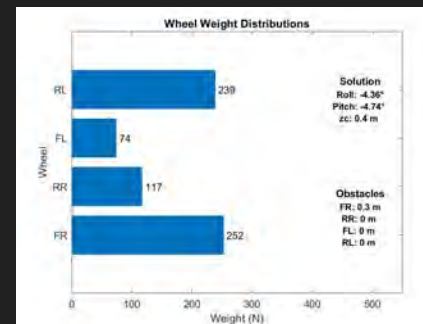

Standard Configuration

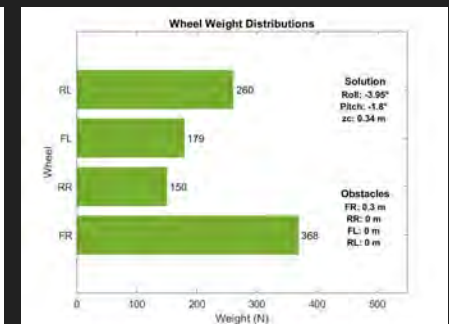

Extended Configuration

37

Weight Distributions (Rear Right on Obstacle)

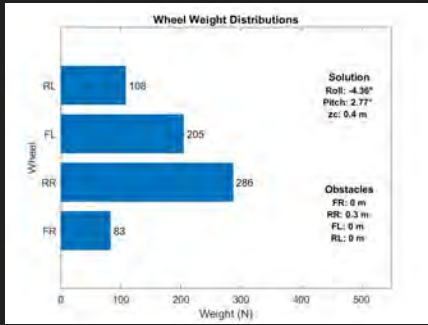

Standard Configuration

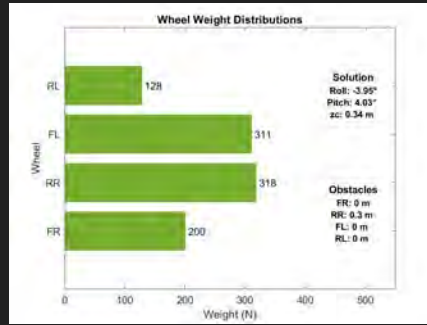

Extended Configuration

38

Motors

39

Motors Trade-Study

Type	Advantages	Disadvantages	Typical Applications	Typical Drive
Brushless DC Motor	<ul style="list-style-type: none"> Long lifespan Low maintenance High efficiency 	<ul style="list-style-type: none"> High initial cost Requires a controller 	<ul style="list-style-type: none"> Hard drives CD/DVD players Electric vehicles 	Multiphase DC
Brushed DC Motor	<ul style="list-style-type: none"> Low initial cost Simple speed control (Dynamica) 	<ul style="list-style-type: none"> High maintenance (brushes) Low lifespan 	<ul style="list-style-type: none"> Treadmill Exercisers Automotive starters 	Direct (PWM)
AC Induction (Shaded Pole)	<ul style="list-style-type: none"> Least expensive Long life High Power 	<ul style="list-style-type: none"> Rotation slips from frequency Low starting torque 	Fans	Uni/Poly Phase AC
AC Induction (Split-Phase Capacitor)	<ul style="list-style-type: none"> High power High starting torque 	<ul style="list-style-type: none"> Rotation slips from frequency 	Appliances	Uni/Poly Phase AC
AC Synchronous	<ul style="list-style-type: none"> Rotation in-sync with frequency Long-life (alternator) 	<ul style="list-style-type: none"> More expensive 	<ul style="list-style-type: none"> Clocks Audio turntables Tape drives 	Uni/Poly Phase AC
Stepper DC	<ul style="list-style-type: none"> Precision positioning High holding torque 	<ul style="list-style-type: none"> Slow speed Requires a controller 	<ul style="list-style-type: none"> Positioning in printers and floppy drives 	Multi-phase DC

Reference: Motor Comparison, Circuit Cellar Magazine, July 2008, Issue 216, Bachiochi, p.78

40

Drive Motor Requirements

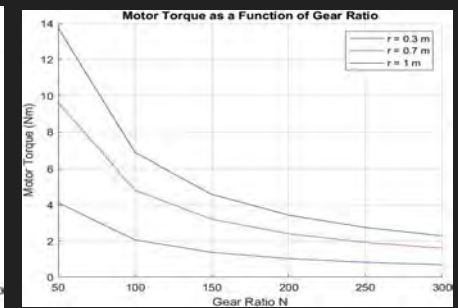
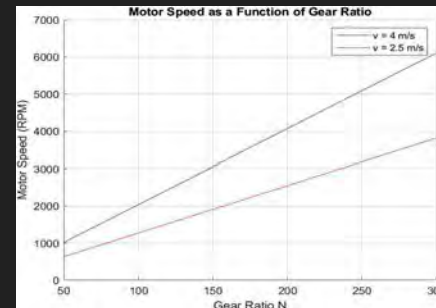

- As per velocity constraints, the rover requires a motor speed a little over 4000 rpm for a gear ratio of 200.

- Motor increases with increase in wheel radius
- For wheel radius = 0.3m, the motor torque required is around 1Nm when the gear ratio is 200.
- Assuming gear efficiency is 80%, we require a motor with torque around 1.25 Nm.

41

Power Ratio of Skid & Steer - Flat Terrain

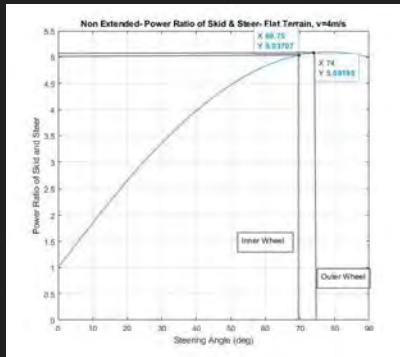

Non - Extended

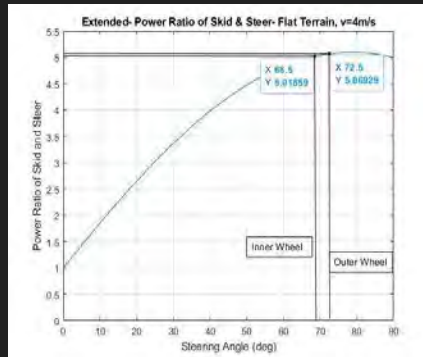

Extended

42

Power Ratio of Skid & Steer - Slope 20 deg

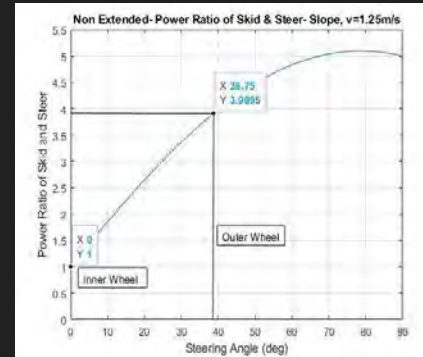

Non - Extended

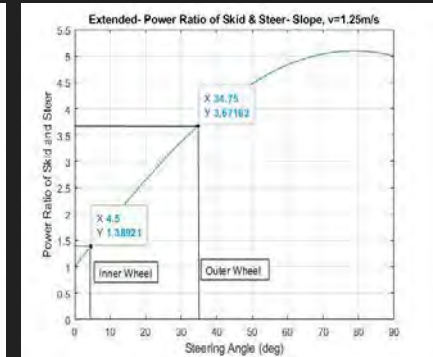

Extended

43

Power - 4 Wheel Skid Turn



Non - Extended



Extended

44

Motor Requirements

- Driving Motor
 - Brushless DC motors were chosen for wheel drive motors.
 - A motor from the RBE(H) 01212 series which complied with the torque and speed requirements was chosen.
- Steering Motor
 - For each wheel steering, a motor with output power ~160 watts is required.
 - A motor from the RBE(H) 01212 series which complied with the power requirements was chosen.

https://npm-ht.co.jp/_assets/wp-content/uploads/2019/12/RBE_Series_Motors_Brochure_01210.pdf

45

Sensors & Perception

Lighting / LiDAR

4 LED Floodlights

- 35,000 lumens each
- 0.6kg each → 2.4kg total
- 30W each → 120W total



4 [Velodyne Puck LITE](#)

- 590g each → 2.4kg total
- 8W each → 32W total

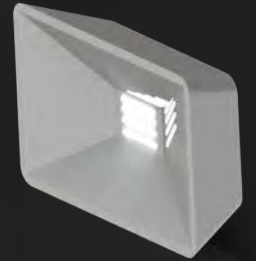

Cameras

2 Sony 4K PTZ cameras

- 1.8 kg each → 3.6 kg total
- 25W (max) each → 50W



4 stereo cameras

- 72g each → 288g
- 2W each → 8W

1 omni-directional camera (Go-Pro Max)

- 163g
- 8 W



Computing

Autonomous path planning and full utilization of LiDAR + cameras requires non-trivial computing power.

Laptop style computer:

- 16GB RAM, 2.3GHz Quad Core CPU, 1.5GB Graphics
- 61W
- 1 kg

Desktop style computer:

- 64+GB RAM, 4.3GHz 8 core CPU, 8GB Graphics
- 650W
- ~6kg

Power

Total Power (W)

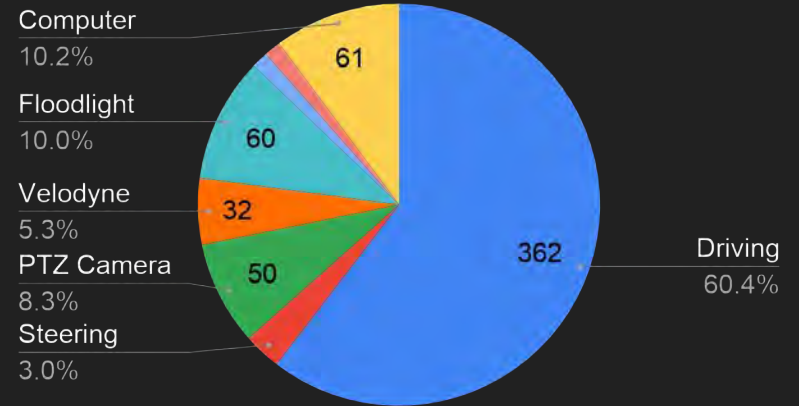

Power

Category	Part	Individual Power (W)	# Required	Duty Cycle (%)	Total Power (W)
Driving / Steering	Driving motors	181	4	50%	362
	Steering motor	181	2	5%	18.1
					0
Sensors / Lighting	PTZ Camera	25	2	100%	50
	Velodyne Puck LITE	8	4	100%	32
	Floodlight	30	2	100%	60
	Stereo Camera	2	4	100%	8
	Omnicaamera	8	1	100%	8
	Computer (Laptop style)	61	1	100%	61
Total Power (W)					599.1
Total Energy - 8 Hour Sortie (Wh)					4792.8
Total Battery Mass (kg)					
@ 400Wh/kg					11.982
@ 260 Wh/kg					18.43

Battery

- 18.5 kg of Tesla's Model 3 Battery (260 Wh/kg)
- OR 12 kg of Tesla's planned battery (400 Wh/kg)

Mass Summary

Mass Overview

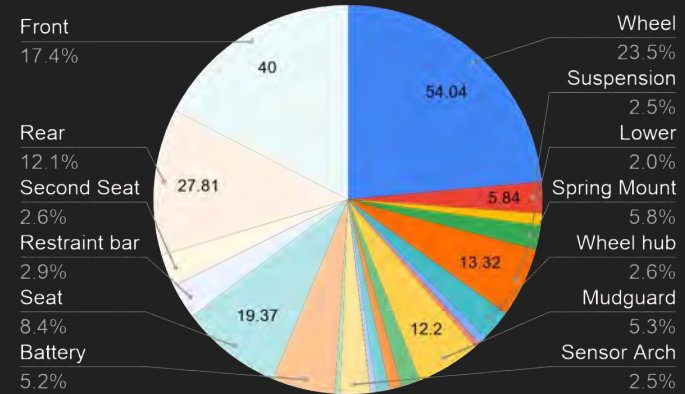

Mass Overview

Category	Part	Material	Individual Mass (kg)	# Required	Total Mass
Suspension / Driving	Wheel	Aluminum 7075-O (SS)	13.51	4	54.04
	Scapemach Spring	Stainless Steel	1.45	4	5.84
	Upper Wishbone	Aluminum 7075-O (SS)	0.59	4	2.34
	Lower wishbone	Aluminum 7075-O (SS)	1.15	4	4.6
	Spring Mount	Aluminum 7075-O (SS)	3.33	4	13.32
	Wheel hub mount	Aluminum 7075-O (SS)	1.47	4	5.88
	Driving motor	Various	0.447	4	1.788
	Steering motor	Various	0.447	2	0.894
	Mudguard	PE Low/Medium Density	3.09	4	12.2
	PTZ Camera	Various	1.8	2	3.6
Sensor / Lighting	Velodyne Puck LITE	Various	0.59	4	2.36
	Floodlight	Various	0.6	4	2.4
	Steering Camera	Various	0.288	4	1.152
	Overcameras	Various	0.163	1	0.163
	Sensor Arch	NYC	5.86	1	5.86
Power	Computer (Laptop style)	Various	1	1	1
	Battery (400Wh/kg)	Various	11.382	1	11.382
Steel	Seat	Very Low Density PE (SS)	19.37	1	19.37
	Restraint bar	Nylon 6/10	0.55	1	0.55
	Restraint bar handles	Aluminum 6061-T6 (SS)	0.12	2	0.24
Aluminum	Second Seat	Very Low Density PE (SS)	5.94	1	5.94
	Second Seat Leg	Aluminum 6061-O (SS)	0.3	1	0.3
Chassis	Rear	Commercially Pure CP-Ti UNS R50400 (SS)	27.81	1	27.81
	Front	Commercially Pure CP-Ti UNS R50400 (SS)	40	1	40
Chassis	High Pin	Chrome Stainless Steel	0.13	4	0.52
	Loading Pin	Plain Carbon Steel	1.56	4	6.24
	Pivot Mechanism	Aluminum 7075-O (SS)	7.36	2	14.72
Total Mass (kg)					250.95

Final Design

Courage Rover - Normal Use

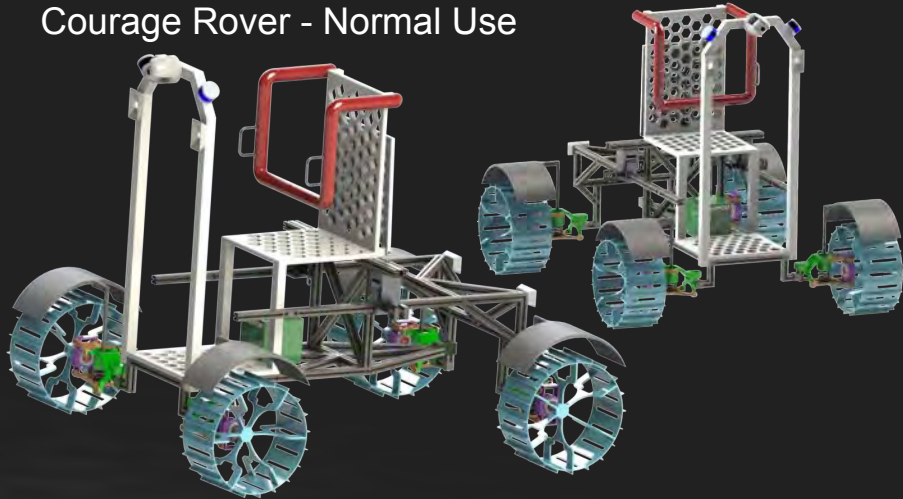

Courage Rover - Normal Use



Courage Rover - Normal Use

- **Mass:** 250.96kg
- **Power:** 599 W
- **Driving Time:** 8 hours assuming a 50% duty cycle for the drive motors.
- **Payload:** one 80kg life support package, two 170kg astronauts
- **Max Speed:** 4 m/s
- **Max Obstacle Size:** 0.3m
- **Max Slope:** 20 deg
- **Driving Modes:** Autonomous [Drive to Destination], Autonomous [Follow Astronaut], Manual



Courage Rover - Normal Use



Courage Rover - Contingency Use



62

Courage Rover - Contingency Use

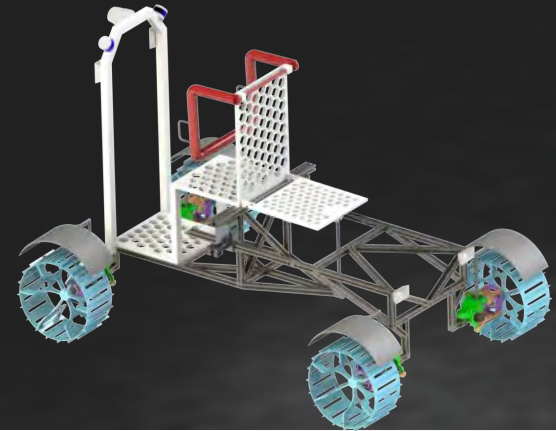

63

Courage Rover - Contingency Use

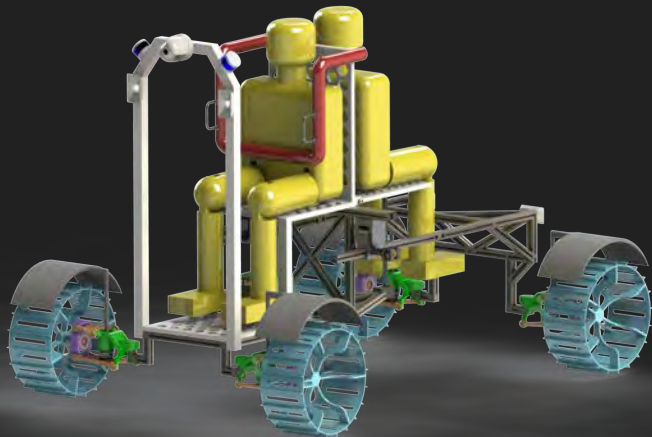

64

Courage Rover - Contingency Use (Rear)

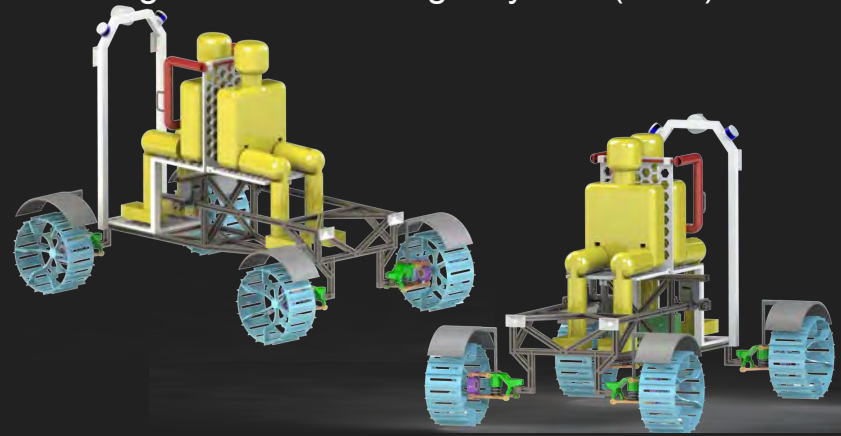

65

Courage Rover - Contingency Use

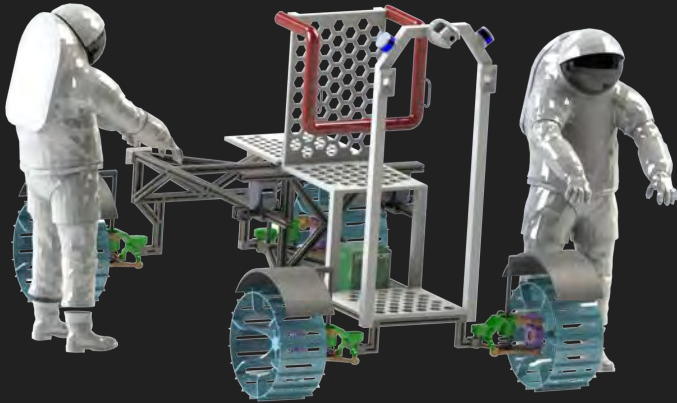

66

Courage Rover - Contingency Use

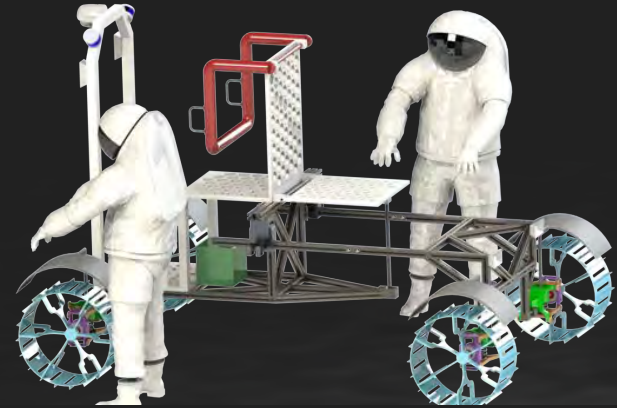

67

Ingress and Egress

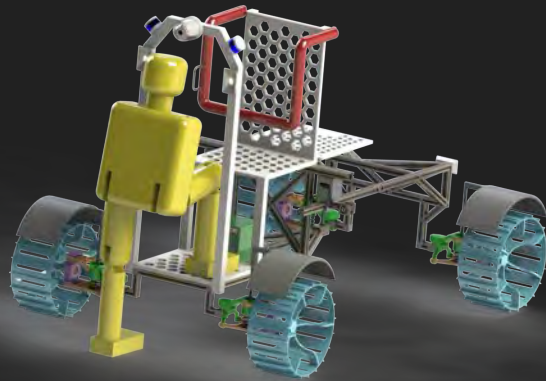

68

Ingress and Egress



69

Driving

Manual [Driven by Astronaut]
Wireless steering wheel + control panel

Autonomous [Drive to Destination]
VR Remote + AR HUD in suit

https://developer.oculus.com/blog/teleport-curves-with-the-gear-vr-controller/?locale=en_US

<https://www.logitech.com/en-gb/products/driving/driving-force-racing-wheel.html> 70

Adherence to Requirements

Category	Required	Actual	Satisfied
Mass	≤ 250 kg	251 kg	- / -
Max Speed	4 m/s	4 m/s	✓
Driving Speed/Range	Avg 2.5 m/s for 6 hours (54 km)	Avg 2 m/s for 8 hours (57.6km)	✓
Max Obstacle Size	0.3 m	0.3 m	✓
Max Slope	20 degrees	20 degrees	✓
Payload (Normal)	170 kg Astronaut + 80 kg payload	170 kg Astronaut + 80 kg payload	✓
Payload (Contingency)	Two 170 kg Astronauts + 80 kg payload	Two 170 kg Astronauts + 80 kg payload	✓
Driving Modes	Autonomous, Follow Astronaut	Autonomous, Follow Astronaut, Manual	✓

71

Earth & Mars Efficacy

Drawbar Pull Comparison

EARTH

$g = 9.8 \text{ m/s}^2$
 $n = 0.5$
 $k_c = 13190 \text{ N/m}^{1.5}$
 $k_\phi = 692200 \text{ N/m}^{2.5}$
Assuming, $K_{\text{shear}} = 13190 \text{ m}$
Soil type = Clay
Drawbar pull = 6154.99 N

MARS

$g = 3.711 \text{ m/s}^2$
 $n = 1$
 $k_c = 28000 \text{ N/m}^2$
 $k_\phi = 7600000 \text{ N/m}^3$
Assuming, $K_{\text{shear}} = 13190 \text{ m}$
Soil type = Sandy Loam
Drawbar pull = 968.26 N

$g = 3.711 \text{ m/s}^2$
 $n = 0.8$
 $k_c = 6800 \text{ N/m}^2$
 $k_\phi = 210000 \text{ N/m}^3$
Assuming, $K_{\text{shear}} = 13190 \text{ m}$
Soil type = Slope soil
Drawbar pull = 7713.51 N

72

73

Stability check (Earth)

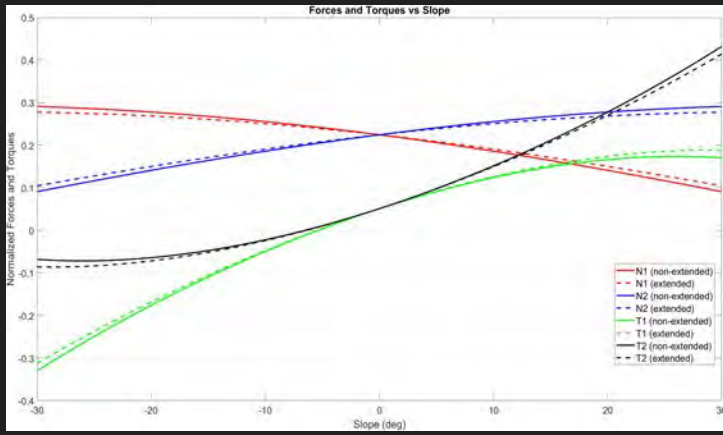

- Design is still valid for Earth environment.
- Uphill slope limit is more than 30 degrees.
- Downhill slope is less than 10 degrees.

74

Stability check (Mars)

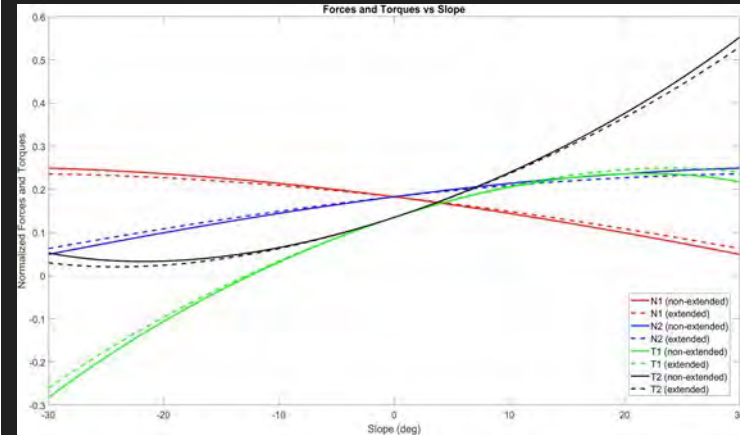

- Design is still valid for Mars environment.
- Uphill slope limit is more than 30 degrees.
- Downhill slope is more than 10 degrees.

75

Turning Radius on Flat Terrain: Earth & Mars

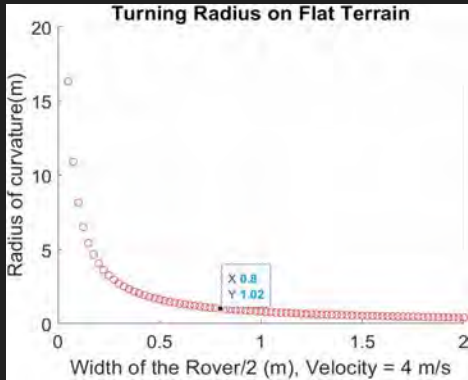

EARTH

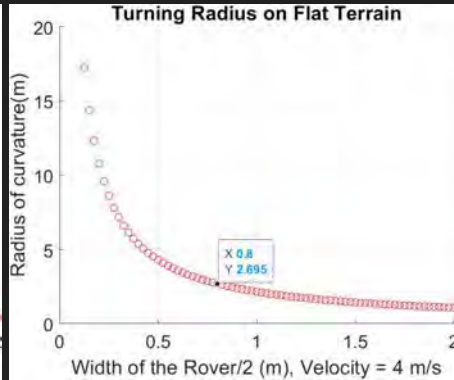

MARS

76

Turning Radius on 20° Slope: Earth & Mars

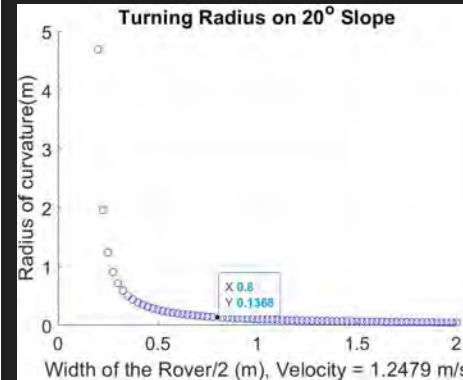

EARTH

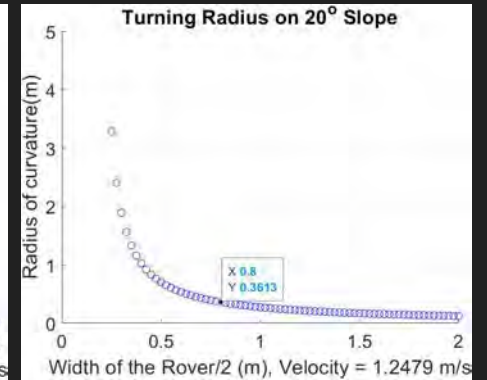

MARS

77

Trafficability

20 Degree Slope - Downhill

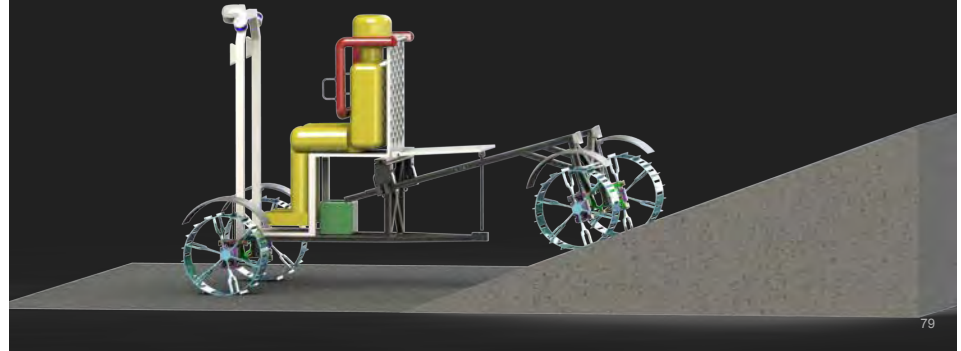

20 Degree Slope - Downhill

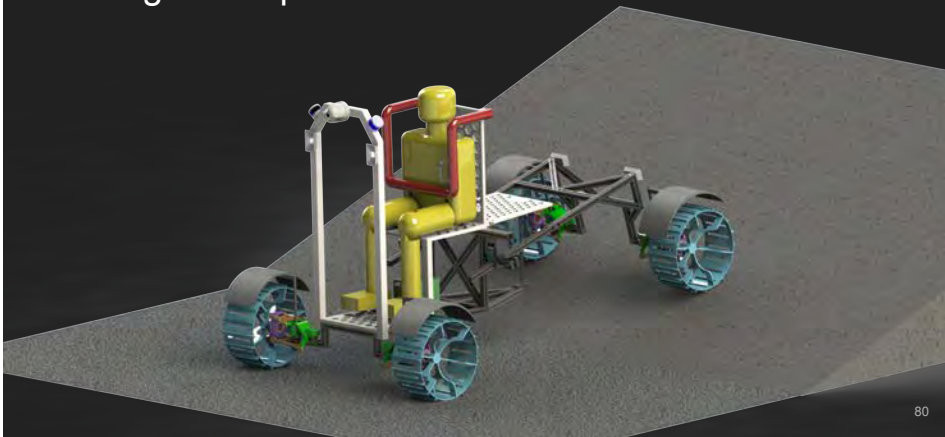

20 Degree Slope - Downhill

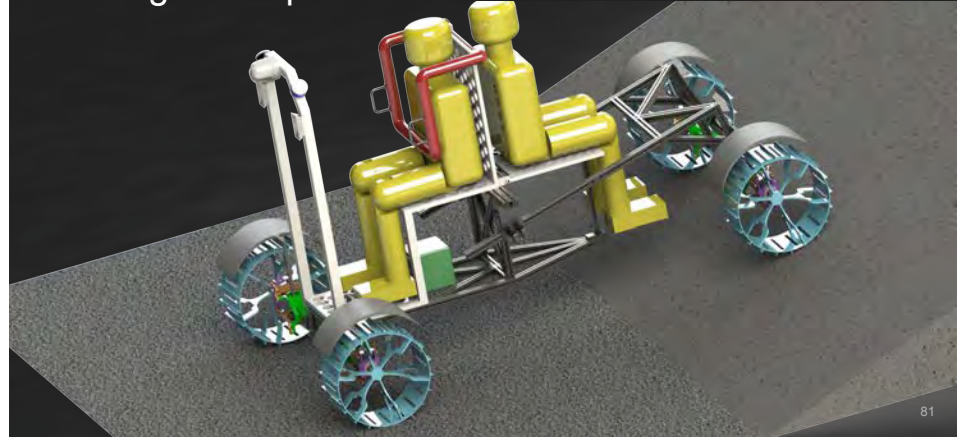

20 Degree Slope - Downhill

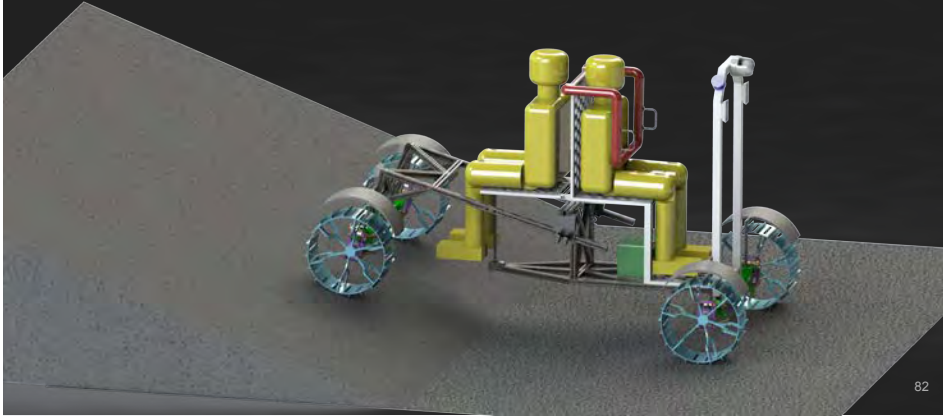

20 Degree Slope - CoM

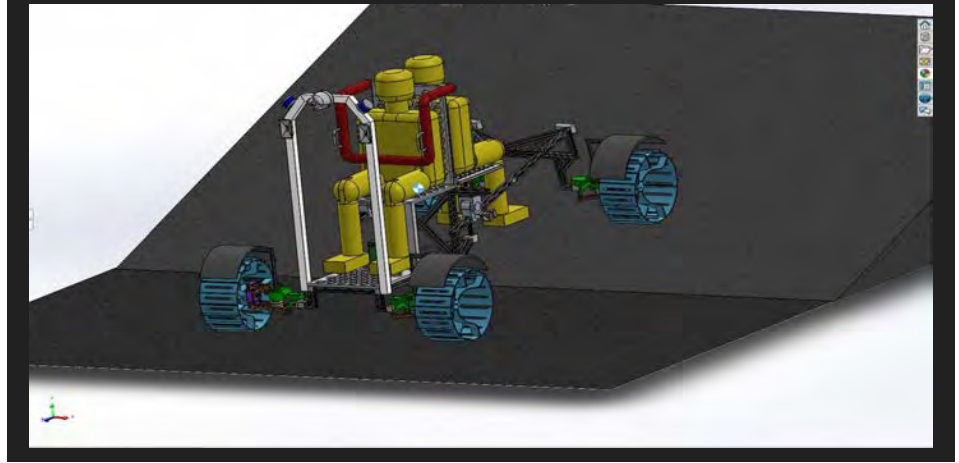

20 Degree Slope - Uphill

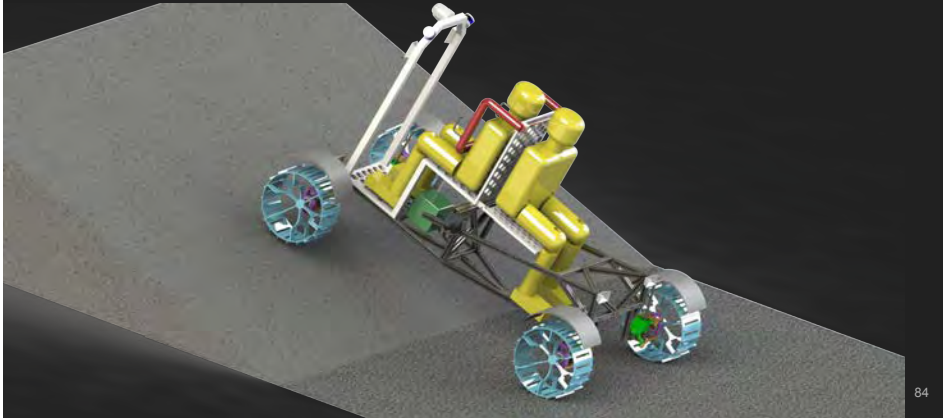

20 Degree Slope - Uphill

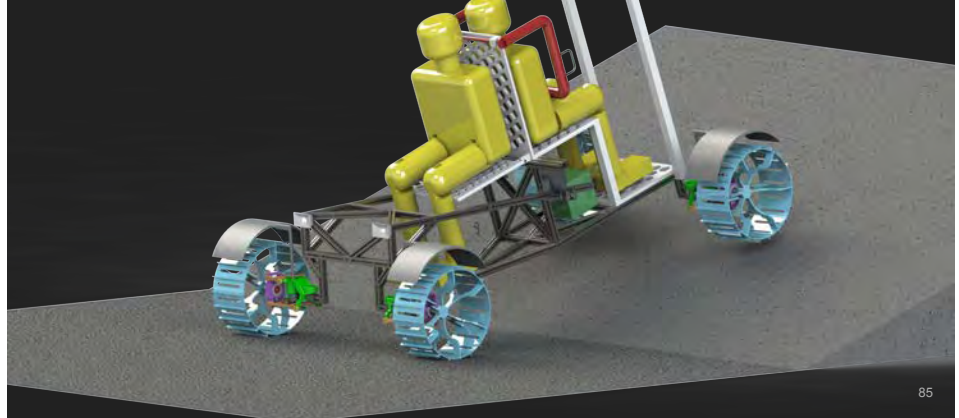

20 Degree Slope - Sideways

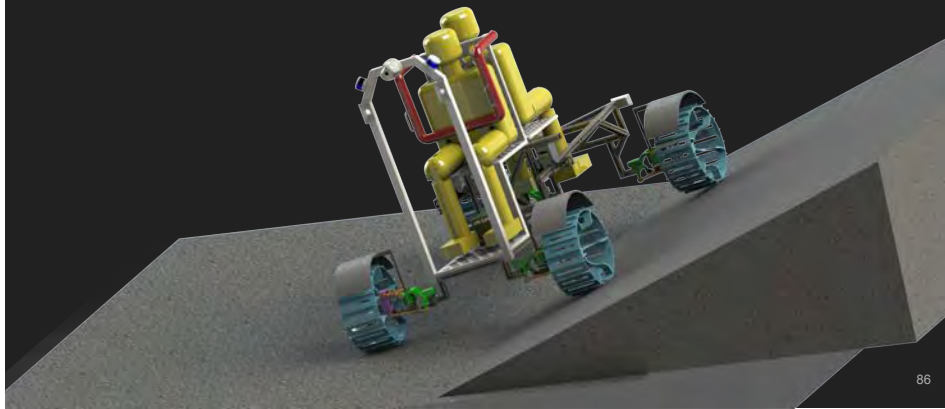

20 Degree Slope - Sideways

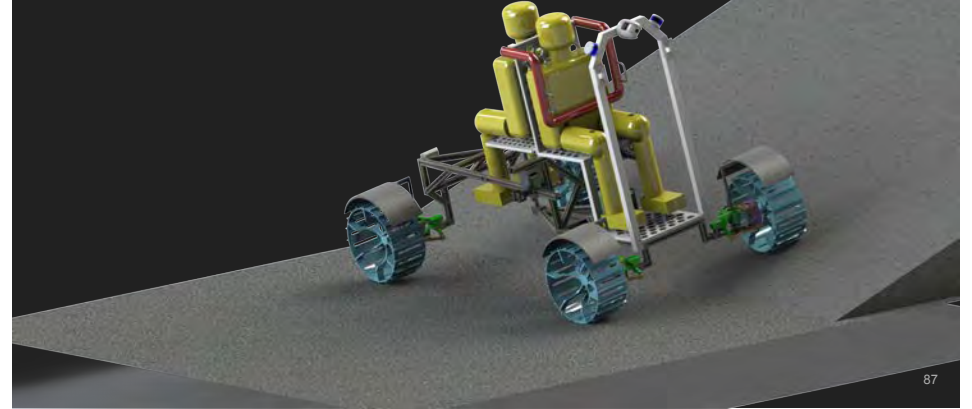

0.1m Obstacle

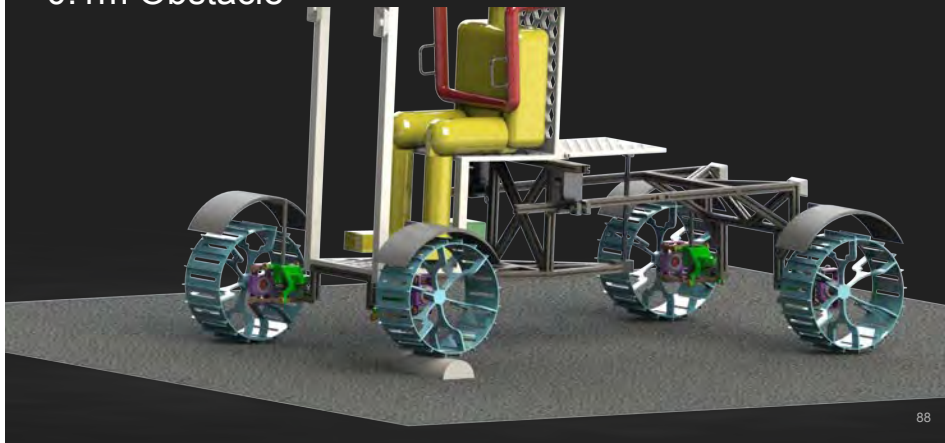

0.1m Obstacle



0.1m Obstacle



0.3m Obstacle

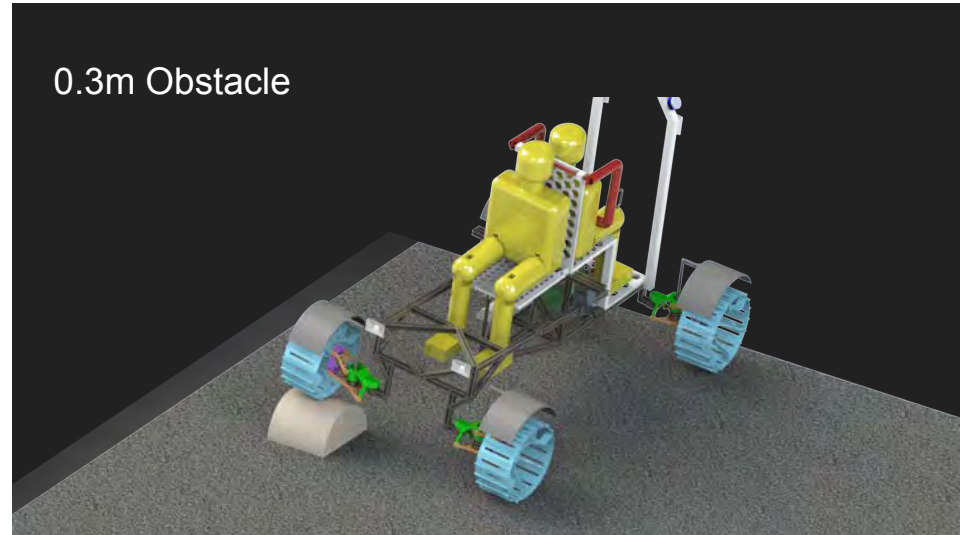

0.3m Obstacle

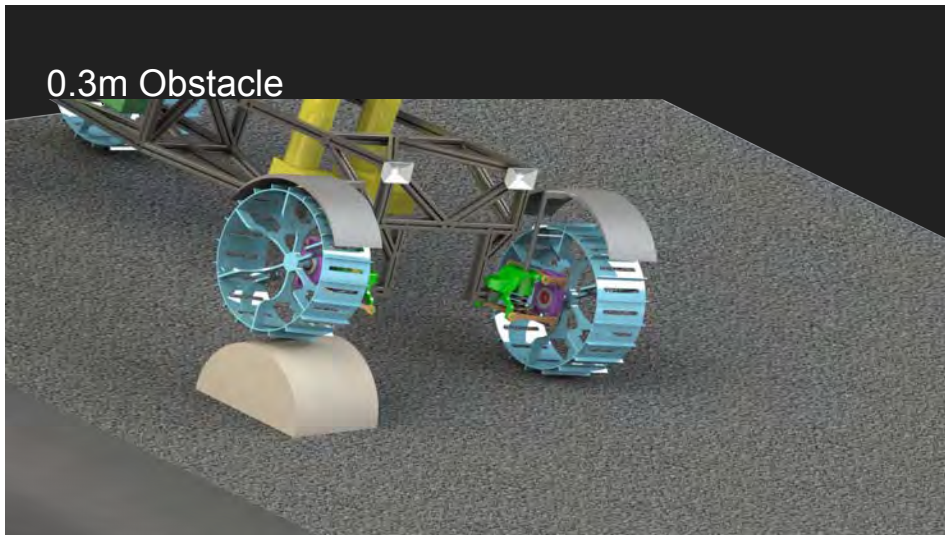

0.1m & 0.3m Obstacle

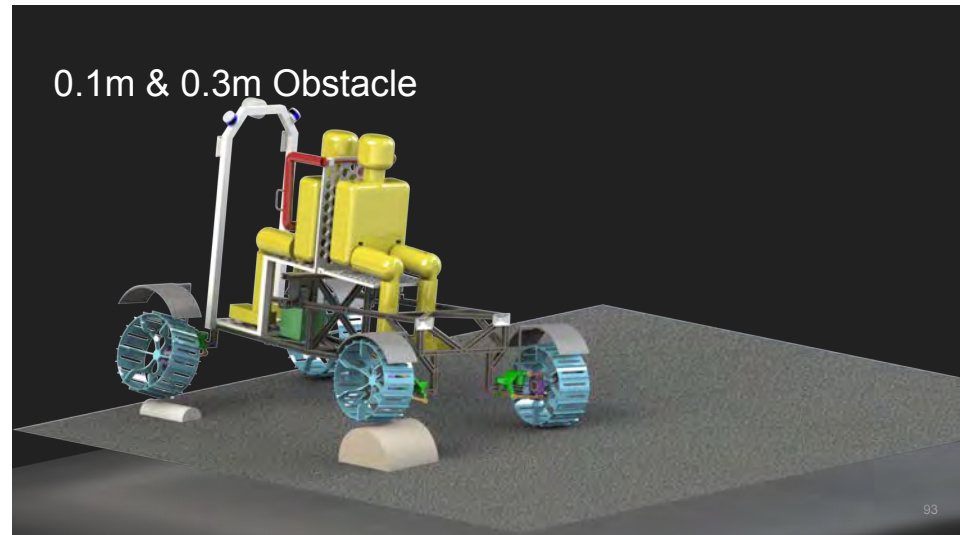

Design Evolution

3. "Design is an iterative process. The necessary number of iterations is one more than the number you have currently done. This is true at any point in time."

4. Your best design efforts will inevitably wind up being useless in the final design."

-Akin's Laws of Spacecraft Design

94

Concept - Mk1 Rover

Umbilical management system

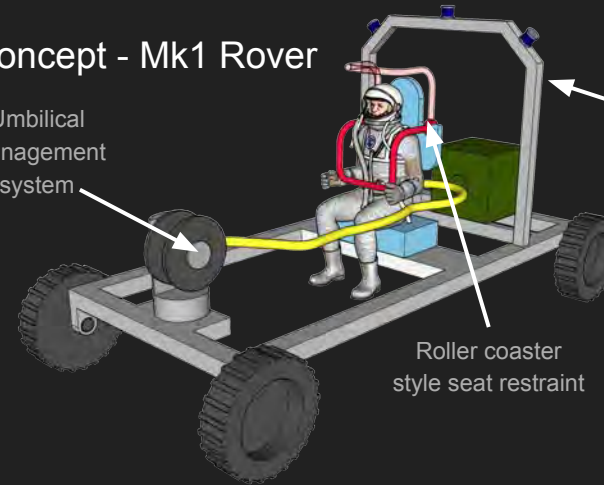

Sensor arch with Velodyne LiDAR pucks, flood lights, and several PTZ cameras (not shown). Configurations with 2 or 3 sensor arches are also possible with this design

Roller coaster style seat restraint

95

Concept - Horsebot

- Bio-inspired legged locomotion

80kg life support payload

Hip rotation joint (not shown)

Four 4 DoF legs

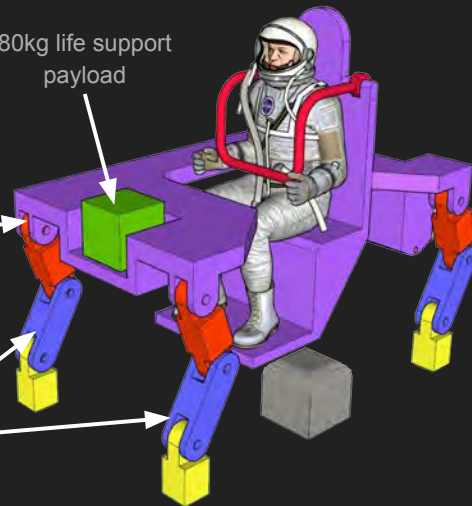

96

Concept - Horsebot

0.3m obstacle

Foldable seat in rear for second astronaut

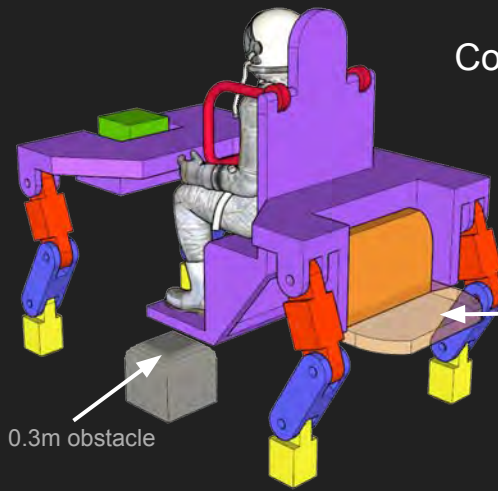

97

Concept - Horsebot - Pros

- Legged locomotion easily clears any obstacle
- Works well on rugged/uneven terrain
- 360° rotation hip joint allows Horsebot to walk sideways (or at arbitrary angle) with its standard gait
- Easy to incorporate second rider
- Seat position keeps center of mass relatively low
- Novel and interesting

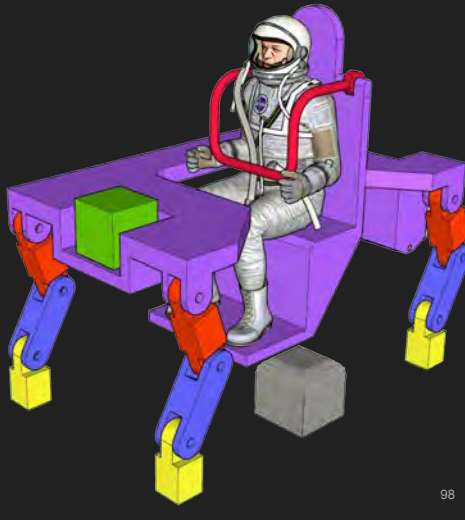

98

Concept - Horsebot - Cons

- Legs are more complex than wheels (more ways to fail)
- Legs require more actuators (more weight)
- 4 m/s would require a medium trot/slow gallop gait, which are only dynamically stable
- Trot/Gallop gait requires much faster and higher torque motors (more weight, more power)
- Additional DoFs (ex: hip abduction, ankle pronation) might be needed for walking on slopes

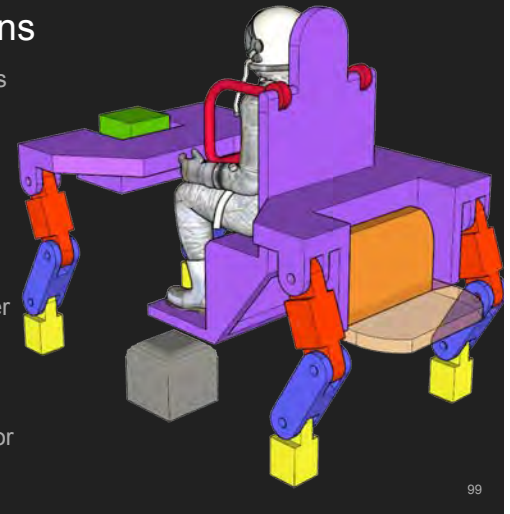

99

Concept - Wheeled Horsebot

Similar to the Horsebot shown in previous slides, this concept includes wheels (mounted on either the ankles or knees) for a reconfigurable driving configuration. Obstacle avoidance would be done at slow speeds with a walking gait, while normal (higher speed) travel on smooth ground would be done with the wheels. This reduces the need for high speed/torque motors for a gallop/trot gait, but requires an additional motor for each wheel. The leg motors act as electromechanical suspension in driving mode.

The increased weight from the extra motors makes this concept impractical for this mission

100

Concept - Strandbeest Locomotion

Locomotion inspired by Theo Jansen's Strandbeests and other similar designs

<https://www.newmobility.com/2013/07/walking-wheelchair-with-12-legs/>

<https://www.newmobility.com/2018/09/spider-chair/>

<https://www.hackster.io/fix4u/strandbeest-a-robotic-project-7e1e23>

101

Concept - Strandbeest Locomotion - Pros

- Legs can be actuated with very few motors
- Chair centric design is compact and relatively lightweight (center photo on previous slide is 96 kg)
- Novel and interesting design

Concept - Strandbeest Locomotion - Cons

- Very high mechanical complexity (*many* ways to fail)
- Well tested on sand, but not well tested on rugged/uneven terrain
- Largely incompatible with stair climbing (due to leg lengths)

102

Concept - 6 Wheel w/ Extension

(wheels not shown)

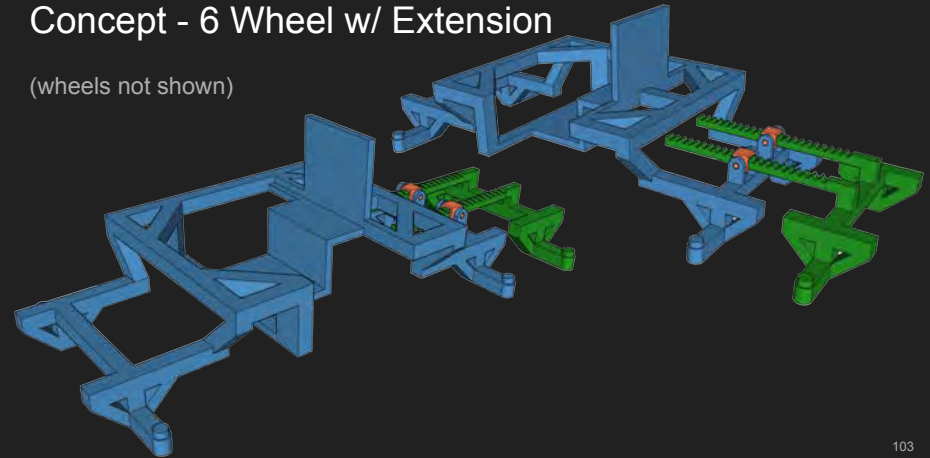

103

Concept - 6 Wheels w/ Extension

This concept involves a 6 wheel rover with two possible configurations. In the normal driving mode, the rear 4 wheels are close together and act as tandem wheels. In the contingency configuration, the chassis extends to provide a wider base so the shifted center of mass (due to the second astronaut) is still centered (front/back) on the rover. In its original implementation, this extension would be actuated via a hand crank which turned a pinion to move the rack (the extender). Subsequent iterations on this design used two extending beams (as shown on the previous slide) for improved stability, as well as an additional pivot (orange, on the previous slide), allowing for the rear wheels to not be coplanar with the rest of the rover (ex: exiting a hill)

104

Crank Actuated Extension

105

Structure

106

Strength Analysis - Rear Arch Cross Beam

$$F = 670 \text{ kg} \cdot 1.62 \text{ m/s}^2 \cdot 0.5$$

$$\delta_{max} = \frac{F a}{24 E I} (3L^2 - 4a^2)$$

$$L = 1.5 \text{ m}$$
$$a = 0.25 \text{ m}$$



<https://mechanicalc.com/reference/beam-analysis>

107

45-9090 Type Aluminum Extrusion

Young's Modulus = $70 \cdot 10^9$ Pa

$$I = 179.4968 \text{ cm}^4$$

$$A = 20.014 \text{ cm}^2$$

Total Mass: **8.104 kg**

Max Deflection (@ $x=L/2$): **0.29 mm**

<https://8020.net/45-9090.html#>

108

45-4545 Lite Titanium Extrusion

Young's Modulus = $170 \cdot 10^9$ Pa

$$I = 9.2029 \text{ cm}^4$$

$$A = 5.167 \text{ cm}^2$$

Total Mass: **3.49 kg**

Max Deflection (@ $x=L/2$): **3.3 mm**

<https://8020.net/45-4545-lite.html>

109

Extension Mechanism - Original

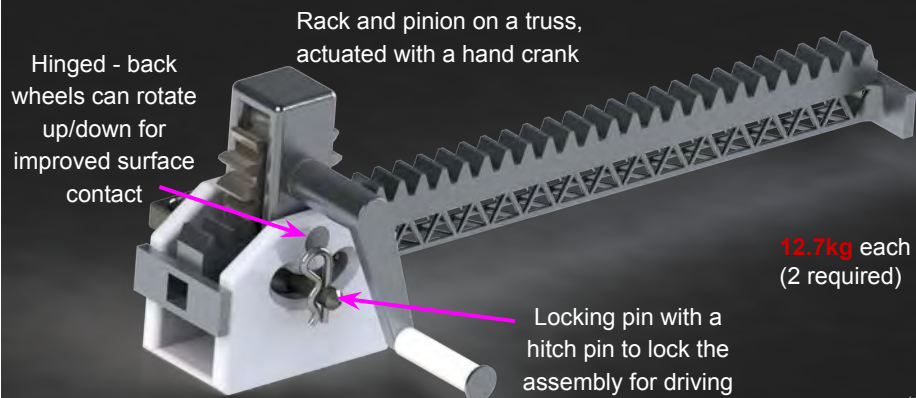

110

Extension Mechanism - Simplified for Weight

Sliding 45-4545-Lite Titanium beam on rollers, actuated by reversing rear wheels

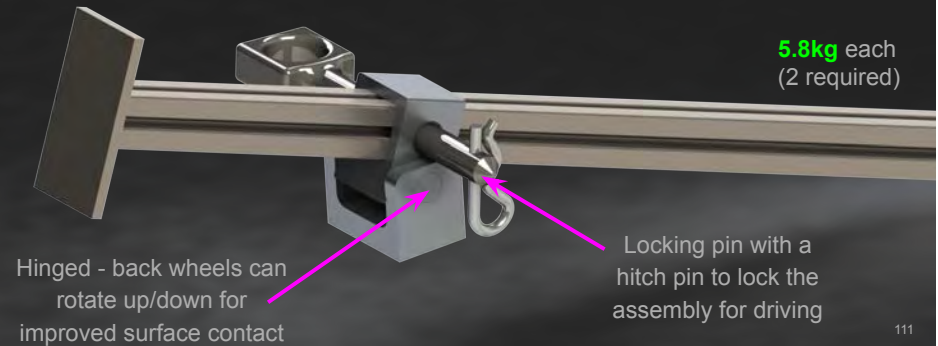

111

Extension Mechanism

This extension mechanism revision was done when the rover still had arched chasses. The benefit of the weight savings in switching profiles and materials far exceeded the small decrease in structural strength. The sliding mechanism is now actuated by driving the rear wheels in reverse (and/or also driving the front wheels forward) to separate the two chassis halves.

Later revisions on this concept continue to use the titanium sliding beam, but offer additional reinforcement elsewhere in the structure (various braces and cross beams) and a much stronger pivot mechanism. The sliding box includes small rollers on the inside (like a [skate wheel conveyor](#)) to minimize friction.

112

6 Wheel Rover, Chassis Arches

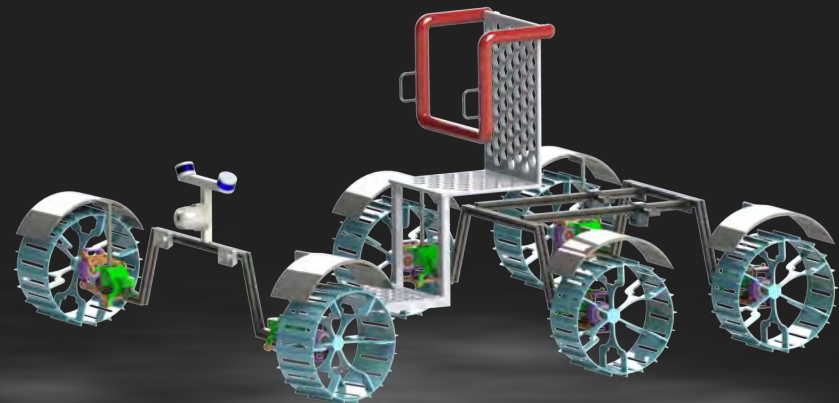

113

4 Wheel Rover, Chassis Arches

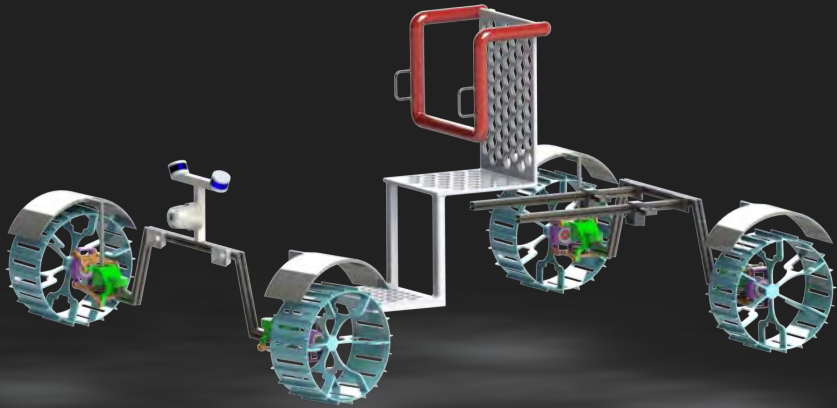

114

4 Wheel Rover, Flat Chassis

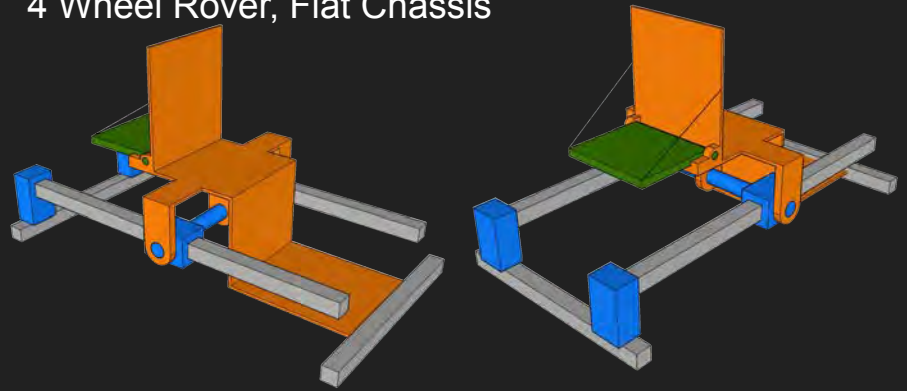

115

4 Wheel Rover, Flat Chassis (Final)

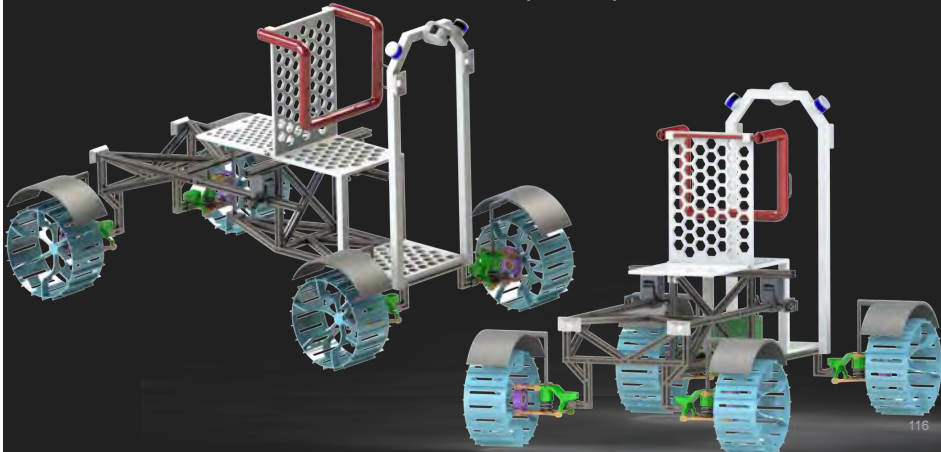

116

Thank You!

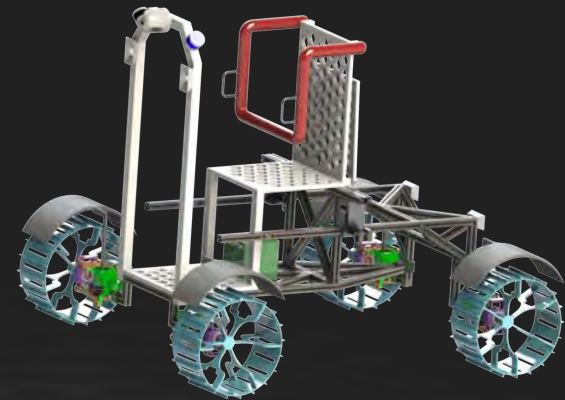

117

Protagonus - Mobile Portable Life Support System

Pat Hoskins, Jaad Lepak, Joe Perrella, Loy McGuire

A. JAMES CLARK
SCHOOL OF ENGINEERING

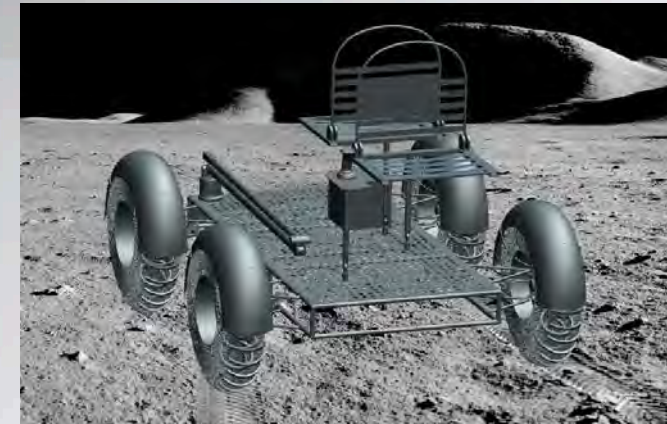

A. JAMES CLARK
SCHOOL OF ENGINEERING

2

Mission Requirements

L1 - 1	Rover shall have a maximum operating speed of at least 4 m/sec on level, flat terrain
L1 - 2	Rover shall be designed to accommodate a 0.3 meter obstacle at minimal velocity
L1 - 3	Rover shall be designed to accommodate a 0.1 m obstacle at a velocity of 2.5 m/sec
L1 - 4	Rover shall be designed to safely accommodate a 20° slope in any direction at a speed of at least 1 m/sec and including the ability to start and stop
L1 - 5	The rover shall have a nominal sortie range of 54 km at an average speed of 2.5 m/sec
L1 - 6	Rover shall be capable of carrying one 170 kg EVA crew and 80 kg of assorted payload in nominal conditions
L1 - 7	Payload may be modeled as a 0.25 m ³ box
L1 - 8	Rover shall be capable of also carrying a second 170 kg EVA crew in a contingency situation. Payload may be jettisoned if design permits

A. JAMES CLARK
SCHOOL OF ENGINEERING

3

Mission Requirements

L1 - 9	Rover design shall incorporate roll-over protection for the crew and all required ingress/egress aids and crew restraints
L1 - 10	A nominal sortie shall be at least eight hours long
L1 - 11	Two rovers must be launched on a single CLPS lander
L1 - 12	A single rover shall mass ≤250 kg
L1 - 13	Rovers shall be developed in time to be used on the first Artemis landing mission
L1 - 14	Rover shall be capable of operating indefinitely without crew present
L1 - 15	Rover shall be capable of being controlled directly, remotely, or automated
L1 - 16	Rover shall be capable of following an astronaut, following an astronaut's path, or autonomous path planning between waypoints
L1 - 17	Rover shall be capable of operating during any portion of the lunar day/night cycle and at any latitude

A. JAMES CLARK
SCHOOL OF ENGINEERING

4

Mission Requirements

L2 - 1	Rover shall maintain a 30% Mass margin
L2 - 2	Rover shall have 30 mm clearance when traversing .3 meter tall obstacles
L2 - 3	Rover shall be able to operate indefinitely while powered from the sun
L2 - 4	Preliminary design, and flight unit testing occur at JPL, Pasadena CA. Concept Study, prototype fabrication, humans in the loop testing, crew training, flight unit fabrication, subsystem verification & validation, subsystem assembly & integration occur at the Johnson Space Center.
L2 - 5	Environmental stress screening and integrated flight unit and lander tests occur at a combination of MSFC, GRC, & JSC. Lastly the integration to the launch vehicle and mission launch occur at KSC
L2 - 6	Disposal excluded. Protogonus is left on the lunar surface after mission completion

Protogonus Subsystem Breakdown

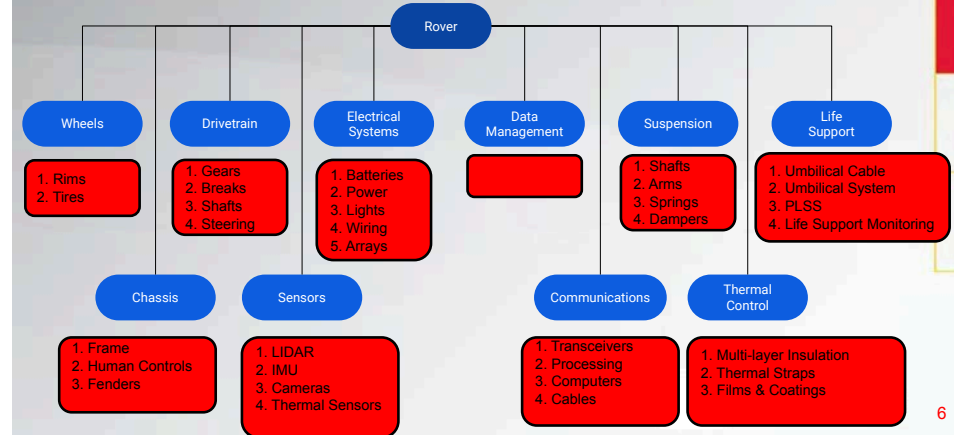

6 Wheel vs. 4 Wheel Initial Analysis

- Low fidelity mass estimate will aid in determining the feasibility of different configurations
 - L1-12 requirement mandates that Protogonus is ≤ 250 kg
 - With a 30% mass margin a Protogonus must be ≤ 175 kg based on L2 - 1 requirement
- 6 wheel configuration:**
 - Improved stability
 - Better handling
 - Fault tolerant (wheel redundancy)
- 4 wheel configuration:**
 - Lighter
 - Less complicated design

4 Wheel Mass Estimate		6 Wheel Mass Estimate	
Chassis	20.8 kg	Chassis	26.8 kg
Wheel & Hub (total)	50.7kg	Wheel & Hub (total)	75.8 kg
Motors (total)	9.88 kg	Motors (total)	14.82 kg
Suspension (total)	8.8 kg	Suspension (total)	13.2 kg
Steering (total)	3.05 kg	Steering (total)	4.42 kg

Effective Drawbar Pull (6 vs. 4 Wheels)

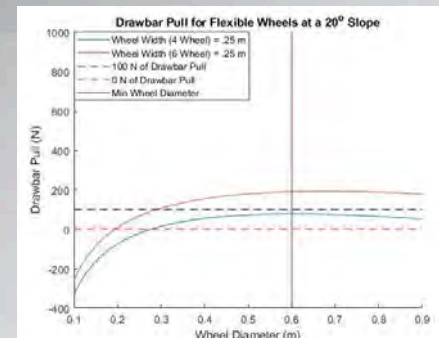

- Analyzed Effective Drawbar pull for 2 Configurations based on the weight distribution on each wheel
- Assuming:**
 - Protogonus is in its 1 crew configuration (~ 500kg)
 - Using the same wheel design
- Conclusion:**
 - Better drawbar pull for the 6 wheel configuration
 - Not worth the additional mass when 4 wheel configuration has satisfactory performance

Conceptual Design

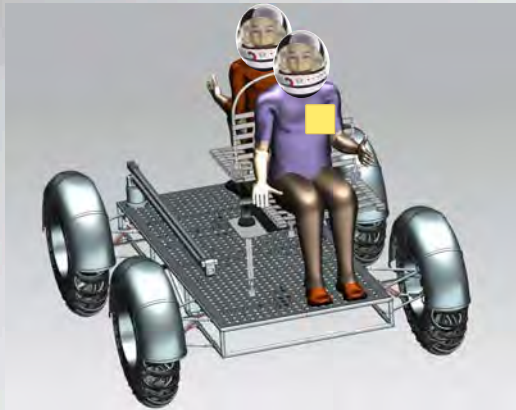

A. JAMES CLARK
SCHOOL OF ENGINEERING

9

Iterative Design

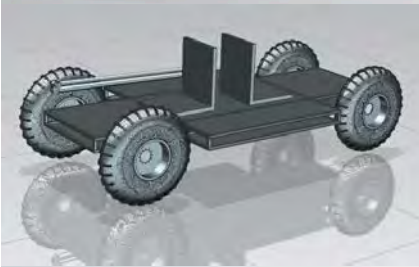

Revision 1

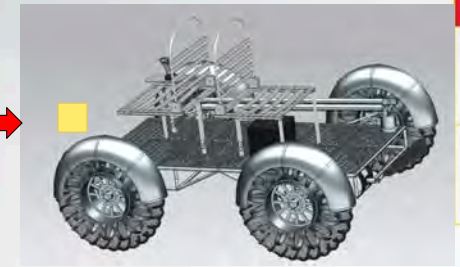

Revision 2

A. JAMES CLARK
SCHOOL OF ENGINEERING

10

Conceptual Design

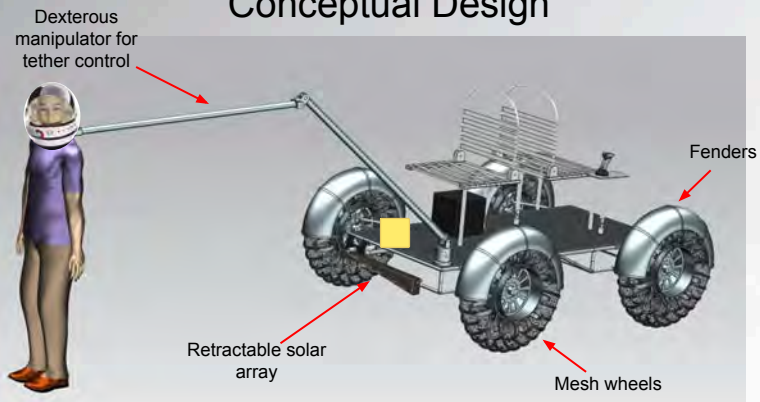

A. JAMES CLARK
SCHOOL OF ENGINEERING

11

Conceptual Design

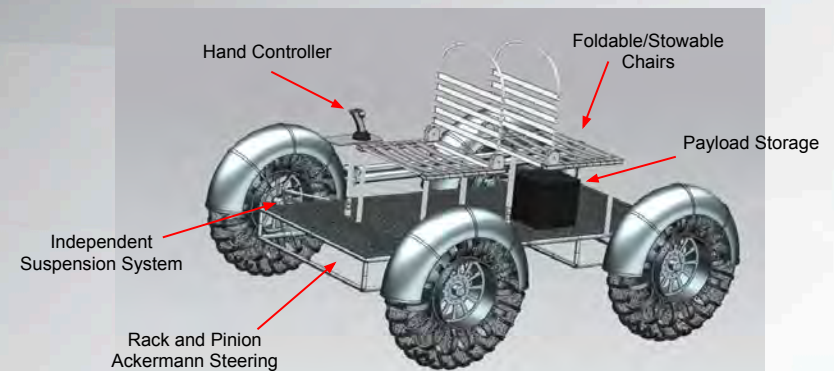

A. JAMES CLARK
SCHOOL OF ENGINEERING

12

Chassis Design

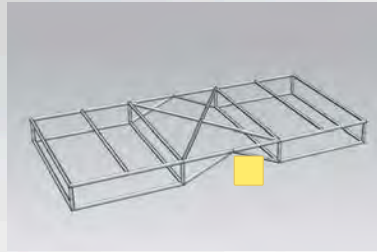
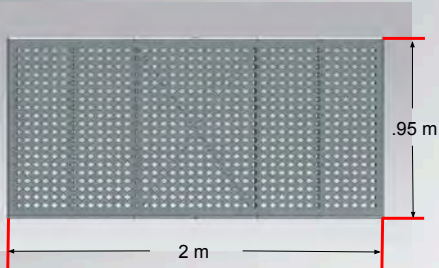

- Chassis consists of beams with circular cross sections for both a lightweight and durable design
- Cycled through different structures and cross sections to find a suitable design

Specifications	
Mass	20.8 kg
Length	2.00 m
Width	.950 m
Thickness	.150 m

R&K
13

Chassis Design

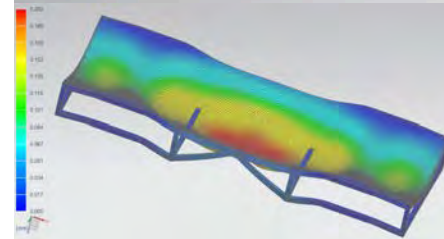

- Created a finite element analysis (FEA) simulation in NX to determine if the chassis structure can support the maximum weight

Assumption:

- Weight is evenly distributed over the chassis
- Max load case (2 Crew Configuration)

Conclusion:

- Max deformation is .2 mm
- Structure is sufficient to support 2 crew

A. JAMES CLARK
SCHOOL OF ENGINEERING
14

Wheel Selection and Methodology

- L1 - 4 requirement mandates Protogonus to traverse 20° slope, under nominal conditions positive drawbar pull could not be achieved to satisfy L1 requirement for rigid wheels
- A thinner and larger wheel would provide the necessary drawbar pull at the expense of the performance metrics (power, mass, wheel performance, etc...)
- Other alternatives were investigated, namely flexible/mesh wheels

Vehicle Weight	810 N
Slip Ratio	.5
Grouser Count	40
Grouser Height	3.5 cm

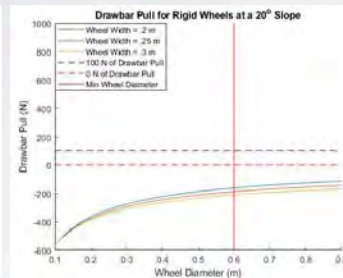
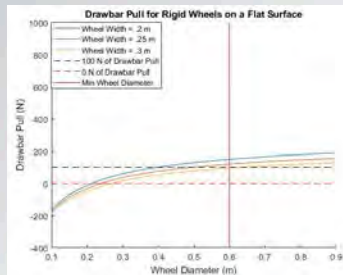

15

Achievable Drawbar Pull with Mesh Wheels

- Mesh Wheel Advantages:
 - Larger contact area with Lunar surface
 - Larger tractive force
 - Smaller compression depth
 - Greater drawbar pull when compared to a equally sized rigid wheel
 - Lighter than rigid wheels
- Mesh Wheel Disadvantages:
 - Bulldozing resistance degrades drawbar pull much quicker as wheel size grows.
 - Not as durable as uniform rigid wheel

Vehicle Weight	810 N
Wheel Deflection	4.45 cm
Slip Ratio	.5
Grouser Count	40
Grouser Height	3.5 cm

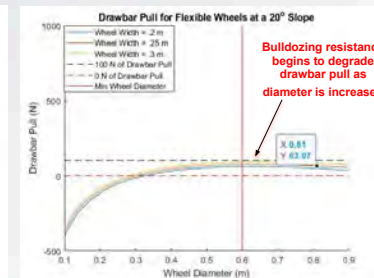
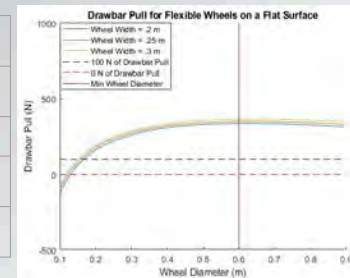

16

Bulldozing Resistance and Tractive Force Evolution

- Initial Observations:
 - Tractive force is much larger with flexible wheels, as the contact area is now much larger
 - Bulldozing resistance for flexible wheels is initially small as the surface contact pressure and compression depth are smaller; However, the design will eventually begin to adversely impact the effective drawbar pull

Vehicle Weight	810 N
Wheel Deflection	4.45 cm
Slip Ratio	.5
Grouser Count	40
Grouser Height	3.5 cm

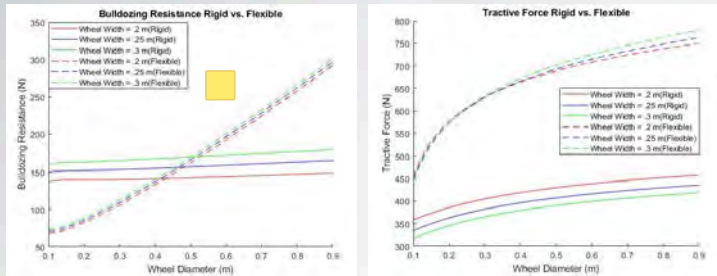

17

Initial Wheel Design

- Repeated deformation without failure using titanium-nickel shape memory alloy
- Allow for a 10% clearance margin from the bottom of the chassis due the thickness of the chassis

Drawbar pull on 20° Slope: ~ 63 N

Vehicle Weight	810 N
Diameter	.810 m
Width	.25 m
Wheel Deflection	4.45 cm
Grouser Count	40
Grouser Height	3.5 cm

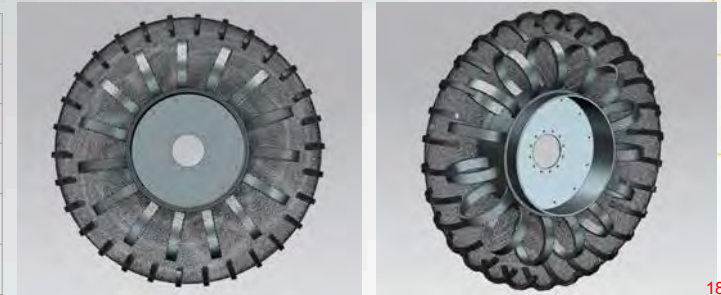

18

Slip Ratio Effects on Drawbar Pull

- After final revision of wheel design positive drawbar pull is still achieved for adverse soil conditions
- Drawbar pull remains positive for slip ratios greater than .23
- The flexibility still exists to modify wheel design for better performance

Vehicle Weight	810 N
Wheel Deflection	4.45 cm
Grouser Count	40
Grouser Height	3.5 cm

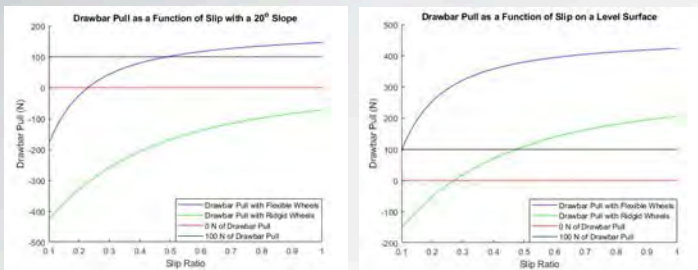

19

Drive Motor Power Analysis

	m = 175 kg	m = 255 kg	m = 425 kg	m = 515 kg	m = 595 kg
P @ 2.5 m/s	144.5182 W	181.6473 W	260.53 W	302.3170 W	339.4462 W
P @ 4 m/s	231.2291 W	290.6358 W	416.8748 W	483.7072 W	543.1139 W

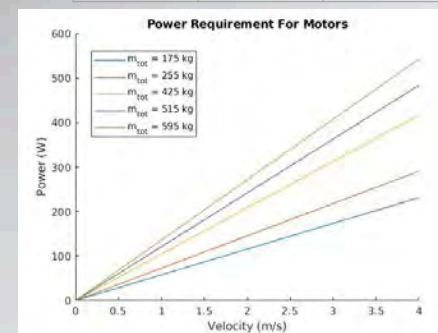

Mass Scenarios:

- Unmanned Rover: 175 kg
- Rover + Payload: 255 kg
- Rover + Payload + 1 Astronaut: 425 kg
- Rover + 2 Astronauts: 515 kg
- Rover + Payload + 2 Astronauts: 595 kg

Total power for 4 drive motors
Power does not change with gear ratio

20

Drive Motor Configurations

4 independent drive motors
 VS
 2 independent motors and 1 coupled back wheel motor

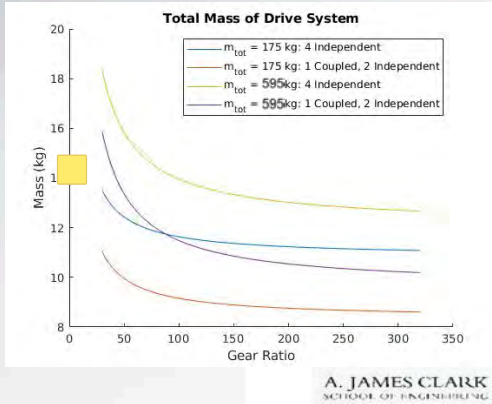

Gear Ratio Analysis

30:1-320:1 gear ratio achievable^[1] with a harmonic drive

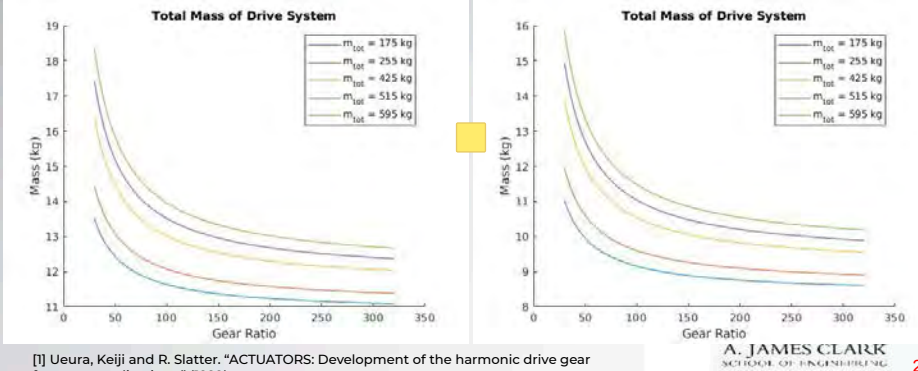

[1] Ueura, Keiji and R. Slatter. "ACTUATORS: Development of the harmonic drive gear for space applications." (1999).

Obstacle Collision Analysis

$V_{limit} = 1.6971 \text{ m/s}$
 $V_{required} \text{ for a } 0.3 \text{ m tall obstacle: } 1.6582 \text{ m/s}$

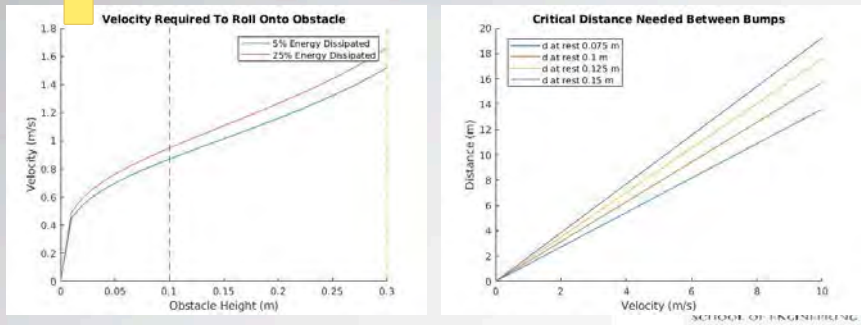

Climbing Analysis

The change in our wheel design has led to better wall climbing
 Analysis is independent of weight

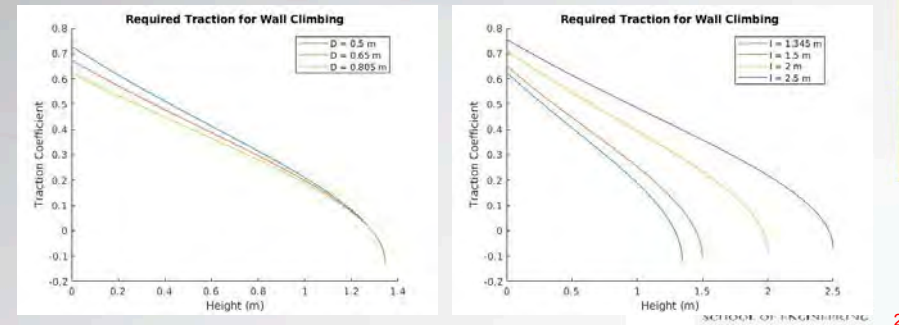

Climbing-Adjusted Motors

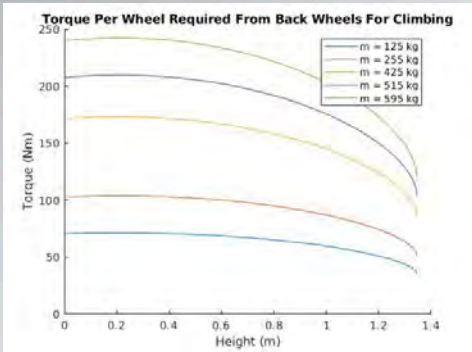

For $N = 320$ and torque of 250 Nm, total drive train mass is 17.3 kg

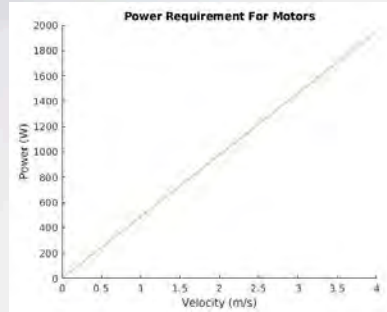

Steering Types

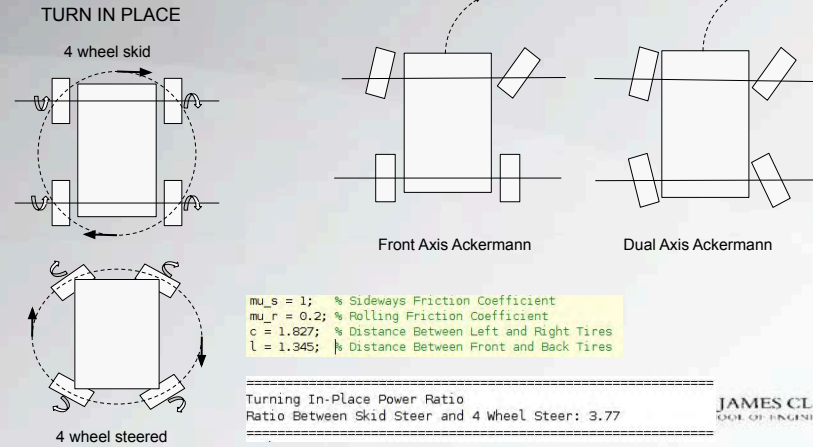

Steering Power Comparison

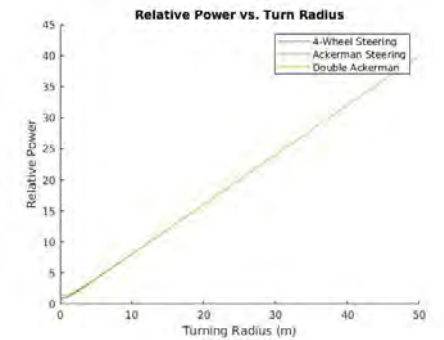
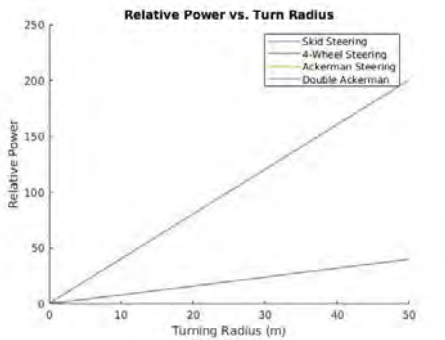

Steering Mechanisms

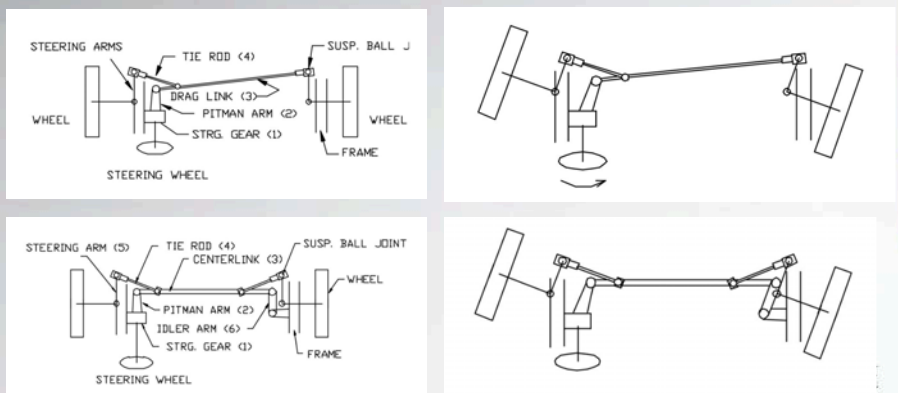

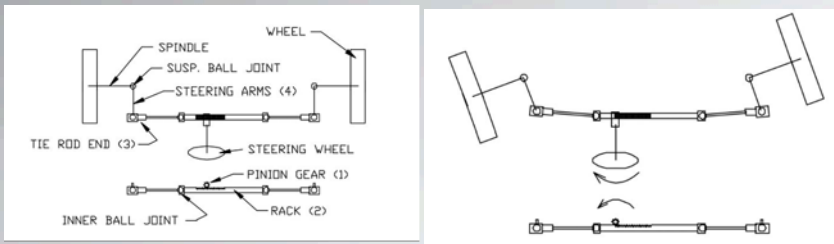

Mechanical Differential Steer Component Breakdown					
Rack & Pinion		Parallel Linkage		Haltenberger Steering	
Component	Mass [kg]	HdcLW [mm]	Component	Mass [kg]	HdcLW [mm]
Motorized rack and pinion (220N)	2.1	85x85x122	Pitman Arm	2.5	17x279x203
Rack (1040 mm)	3	20x20x1040	Center Link	5	23x889x203
			Tie rod (x2)	2.5	127x533x152
			Idler Arm	2	203x304x228
			Servo Motor (1Hp,143Nm)	3	
Steering Arm (x2)	2		Steering Arm (x2)	2	
Suspension Ball Joint & Spindle (x2)	2.5		Suspension Ball Joint & Spindle (x2)	2.5	
Total	12		Total	23.5	

Steering Trade

Steering System	MECHANICAL DIFFERENTIAL			ELECTRONIC DIFFERENTIAL		Skid Steer
	Rack & Pinion	Parallel Linkage	Haltenberger Steering	2 Wheel Ind.	4 Wheel Ind.	
Steer Axis	Front	Front	Front	Front or Rear	Dual	Dual
Number of Actuators	1	1	1	2	4	0
Actuator Mass	2.1	3	3	9.5	9.5	0
Steering Mechanism	Motorized pinion linear actuator (220N),	motorized pitman arm control, Hollow Rotary Actuator (1Hp,12Nm, Vdc)	motorized pitman arm control, Hollow Rotary Actuator (1Hp,12Nm, Vdc)	Individual steer motors control wheel steer angle, Hollow Rotary Actuator (50Nm)	Individual steer motors control wheel steer angle, Hollow Rotary Actuator (50Nm)	Vary individual drive motor power
Mechanism Mass	12.0	23.5	18.0	2.0	2.0	0.0
Total Mass Estimate	14.1	26.5	21.0	21.0	40.0	0.0
Contingency Steer Mechanism	Skid	Skid	Skid	Skid	Front/rear & skid	None
Anecdotal Performance Notes	Precise driving geometry, low carrying capacity, placement inflexibility	Precise driving geometry, high carrying capacity, placement flexible, relatively high weight	Imprecise driving geometry, high carrying capacity, placement flexible	Requires marginally larger power storage due to electronic control	Requires much larger power storage due to electronic control	Requires exponentially larger power storage due to electronic control, and skid inefficiency

Steering System Mass Comparison

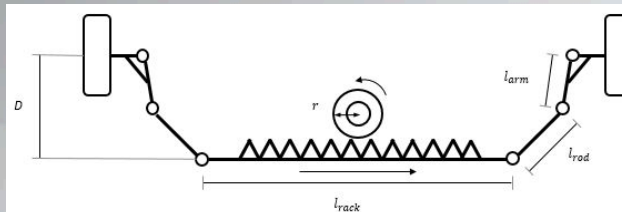
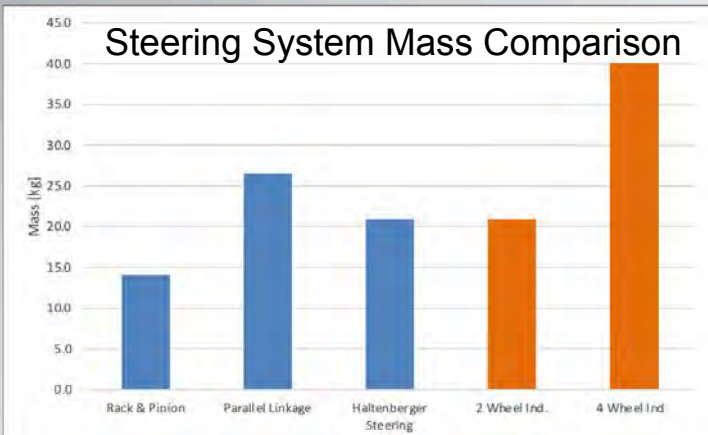

Diameter of ...	0.35
Arm Length	0.15
Rack Length	1.1
Rod Length	0.4149

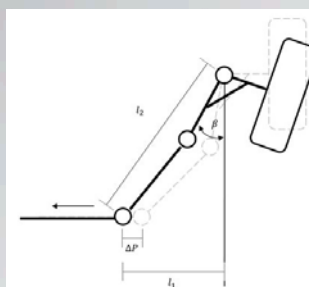

$$l_1 = \frac{TW - l_{rack}}{2} - \Delta P$$

$$l_2^2 = l_1^2 + D^2$$

$$\Delta P = r \delta_m$$

$$\beta = \frac{\pi}{2} - \tan^{-1} \left[\frac{D}{l_1} \right] - \cos^{-1} \left[\frac{l_{arm}^2 + l_2^2 - l_{rod}^2}{2 l_{arm} l_2} \right]$$

Ackermann Performance

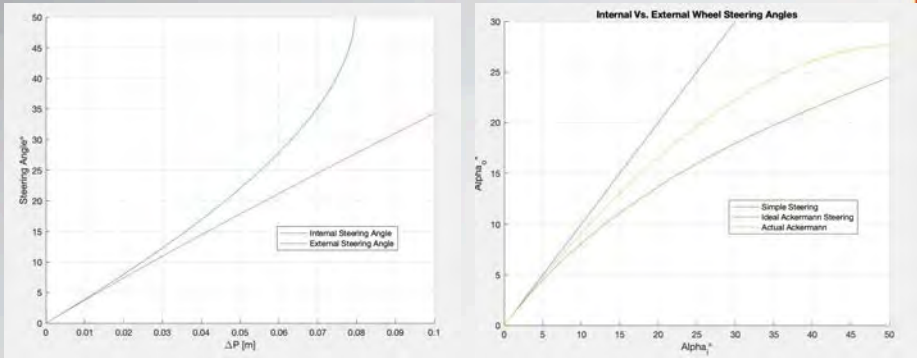

Steering Limits

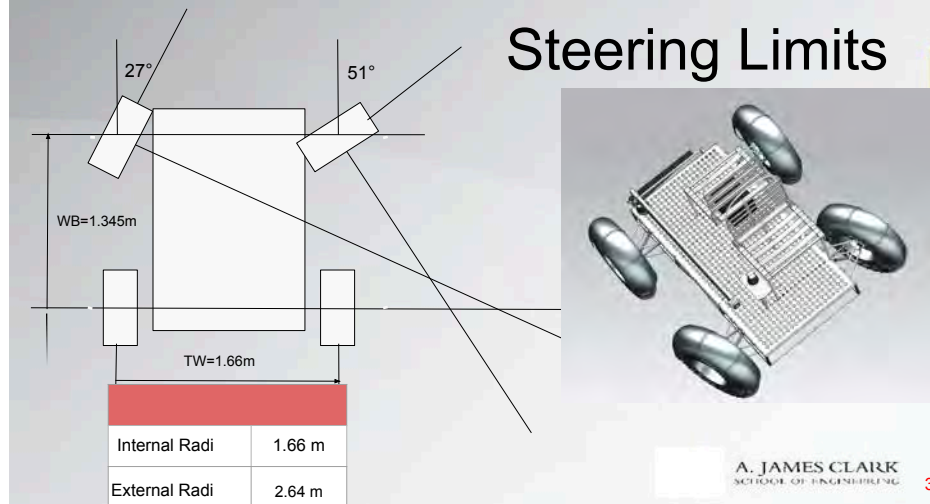

Steering Actuator

Total Mass [kg]	595
Weight Wheels [N]	241
Wheel Width [m]	0.25
Tao [Nm]	16.07

2 Wheels controlled per actuator.
Tao_t = 32.13 [Nm]
At 0.15m, F required is 220N.

$$\tau = \mu \frac{W_w b}{3}$$

Steering Actuator



Item # LM4B500AZAC-1, High-Speed Rack and Pinion System (100 mm Stroke). The Rack and Pinion System is a linear actuator in which a rack and pinion mechanism with a motor have been combined. The motor utilizes a battery-free absolute sensor, which allows for high positioning accuracy and high-load transportation.

Maximum Acceleration	1 m/s ²
Thrust	220 N
Push Force	220 N
Max. Holding Force	220 N
Minimum Travel Amount	0.01 mm

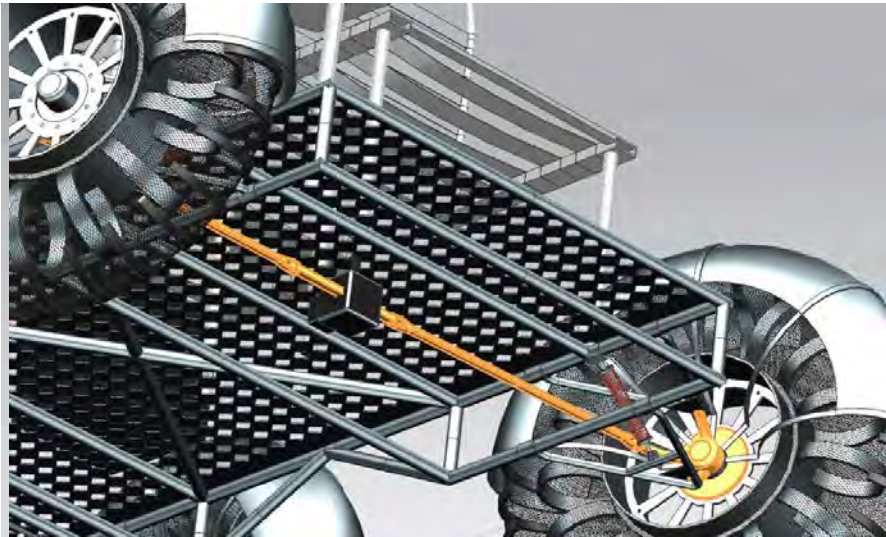

37

Suspension System Prototypes

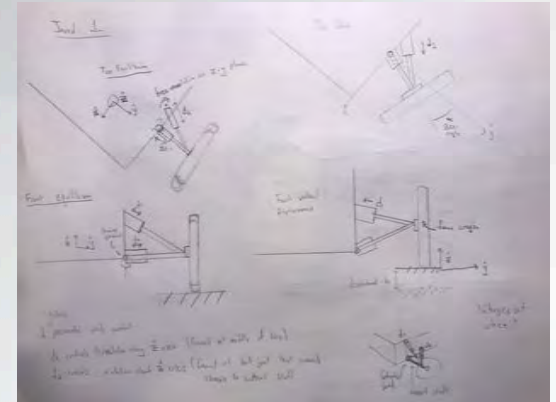
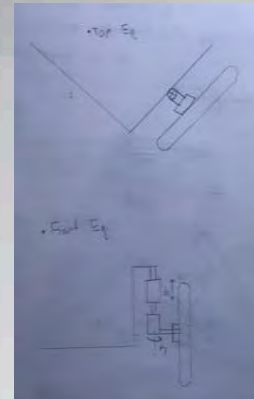

A. JAMES CLARK
SCHOOL OF ENGINEERING

38

Suspension System Prototypes

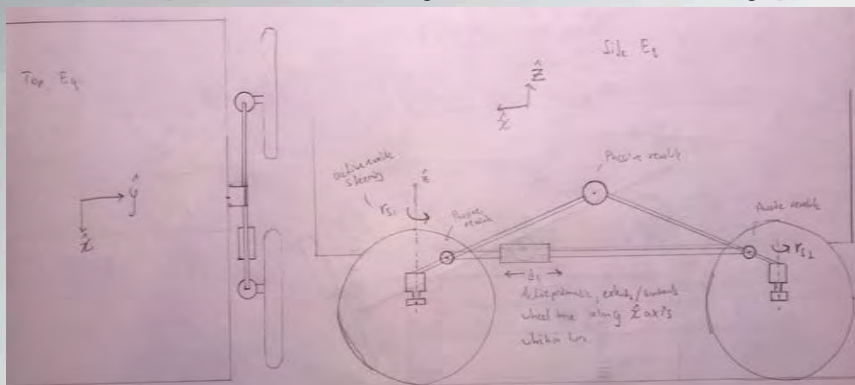

A. JAMES CLARK
SCHOOL OF ENGINEERING

39

Suspension System Prototypes

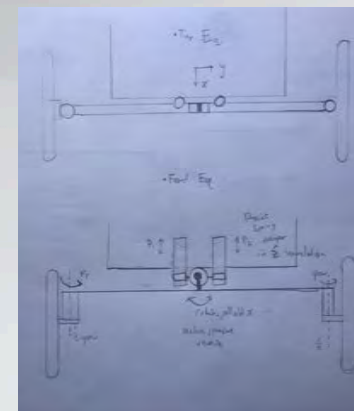

A. JAMES CLARK
SCHOOL OF ENGINEERING

40

Suspension System Prototypes

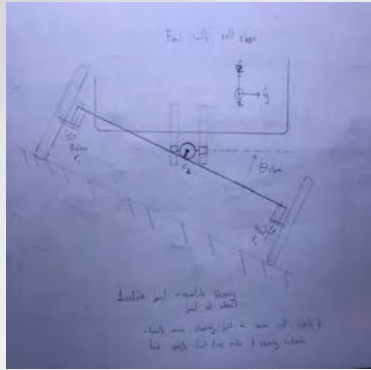

DESIGN OF A HIGH-ABILITY LOW-WEIGHT LUNAR ROVER: A. Wismansaker, M. Roman, T. Hunt, and D.P. Miller
University of Oklahoma, 800 App Ave, Box 210, Norman OK, 73069 USA
awis@ou.edu, bella1@ou.edu, dpmiller@ou.edu & hmroman@ou.edu

A. JAMES CLARK
SCHOOL OF ENGINEERING

41

Suspension System Trade

Benefactor Scores (more = better) Detractor Scores (less = better)

$$S_t = \frac{x_t}{\sum_{t=1}^n x_t}$$

$$x_t = \frac{\sum_{t=1}^n y_t}{y_t} \quad S_t = \frac{x_t}{\sum_{t=1}^n x_t}$$

ex. Active DOF, passive suspension DOF

ex. mass of system, turn radius

A. JAMES CLARK
SCHOOL OF ENGINEERING

42

Suspension System Trade

	Active Trans DOF	Active Rot DOF	System Mass (ranked)	xt_mass	Turning Radius (ranked)	xt_turn
Dual Prism	1	2	3	7.0	3	4.0
Rocker	1	0	2	10.5	1	12.0
Dual Revolute	1	2	5	4.2	1	12.0
Front Roll	1	1	6	3.5	2	6.0
Active Wishbone	1	2	4	5.3	3	4.0
Passive Wishbone	0	0	1	21.0	2	6.0
Sum	5	7	21	51.45	12	44
Score Type	Benefactor	Benefactor	Detractor		Detractor	
Weight	10	10	50		30	
	Trans Score	Rot Score	Mass Score		Turning Score	Total Score
Dual Prism	0.200	0.286	0.14		0.09	14.4
Rocker	0.200	0.000	0.20		0.27	20.4
Dual Revolute	0.200	0.286	0.08		0.27	17.1
Front Roll	0.200	0.143	0.07		0.14	10.9
Active Wishbone	0.200	0.286	0.10		0.09	12.7
Passive Wishbone	0.000	0.000	0.41		0.14	24.5
Sum	1.000	1.000	1.000		1.000	100

A. JAMES CLARK
SCHOOL OF ENGINEERING

43

Suspension System Trade

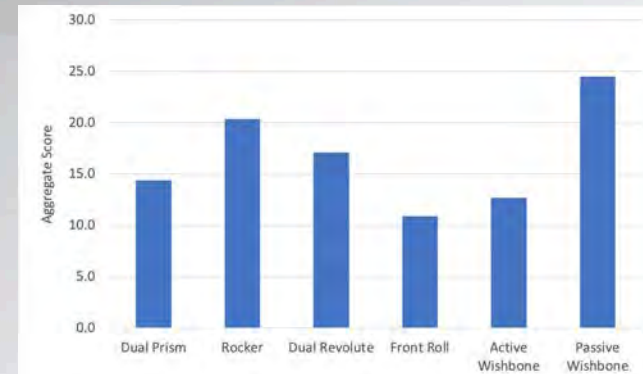

A. JAMES CLARK
SCHOOL OF ENGINEERING

44

Suspension CAD

Double Wishbone



A. JAMES CLARK SCHOOL OF ENGINEERING

Suspension

Undamped Single Wheel

- Goal is 1 - 1.5 Hz suspension frequency for rider comfort, not to exceed 2.5 Hz
- Interested in suspension parameters that will keep mass configurations involving astronauts within this goal
- Spring Stiffness of 7000 N/m satisfies goal

Mass Configuration	Suspension Spring Deflection at rest [m]
No Payload	0.03
Payload Only	0.05
1 Astronaut w/Payload	0.09
2 Astronauts w/out Payload	0.11
2 Astronauts w/Payload	0.13

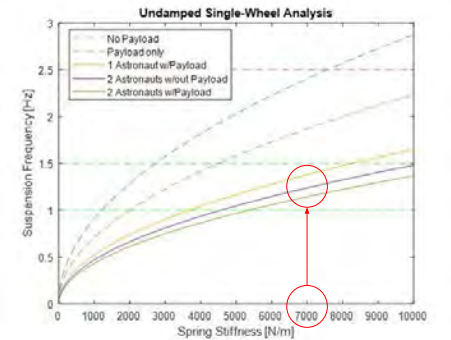

A. JAMES CLARK SCHOOL OF ENGINEERING

Suspension

Undamped Multi Wheel

- For undamped multi-wheel analysis, a spring stiffness of 13,000 N/m brings front and rear suspension frequencies within desired range
- To maintain desired frequencies, C.M. must be 0.57 to 0.77 meters from front wheel axle

Mass Configuration	Suspension Spring Deflection at rest [m]
No Payload	0.02
Payload Only	0.03
1 Astronaut w/Payload	0.05
2 Astronauts w/out Payload	0.06
2 Astronauts w/Payload	0.07

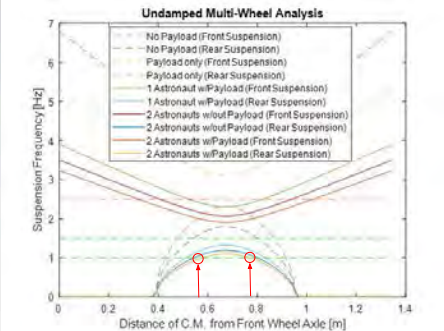

A. JAMES CLARK SCHOOL OF ENGINEERING

Suspension

Undamped Tire Stiffness

- Looking at recommended tire stiffness to keep suspension frequency within desired range with 13,000 N/m spring stiffness
- Recommended tire stiffness is 15,000 N/m

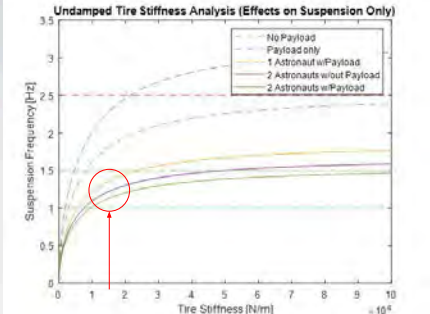

A. JAMES CLARK SCHOOL OF ENGINEERING

Suspension

Critical Distance

- At nominal speed (2.5 m/s) operating at desired suspension frequency (1-1.5 Hz), critical distance between bumps are 1.67 to 2.5 meters

Vehicle Speed [m/s]	Suspension Frequency [Hz]	Critical Distance between Bumps [m]
0.1	2.5	0.04
0.5	1	0.5
2.5	1	2.5
2.5	1.5	1.67
4	1.5	2.67

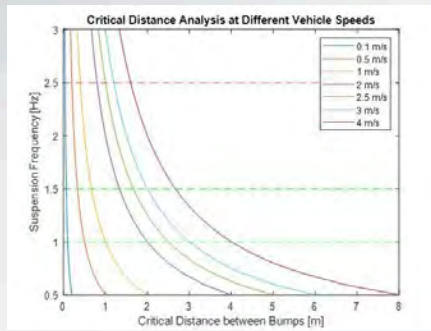

Suspension

Damping

- Looked at adding damping to improve comfort
- Desired to have a damping ratio of 1, and prefer underdamped performance since suspension specifications will vibrate at 1-1.5 Hz (comfortable range); An overdamped system would be less comfortable
- Choosing a damping coefficient of 4700 N.s allows all configurations to have either a damping ratio of 1 or be underdamped

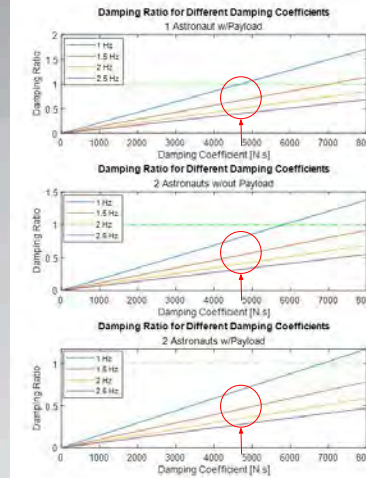

Suspension

Mass Spring Damper

- Used ODE45 to plot suspension performance
- Spring stiffness = 13,000 N/m
- Damping coefficient = 4,700 N.s
- Initial displacement is the deflection of suspension at rest for each mass configuration

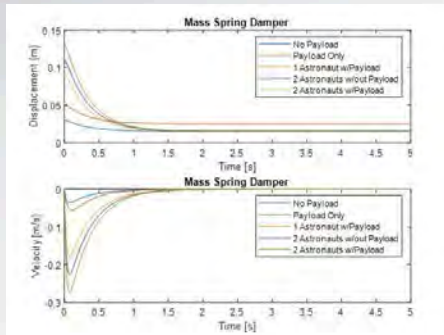

Suspension

Alternative Design

- With a spring stiffness of 2,000 N/m, suspension frequency ranges between 0.4 - 0.9 Hz
- Effects of this frequency range on the human body are motion sickness and dizziness [2]

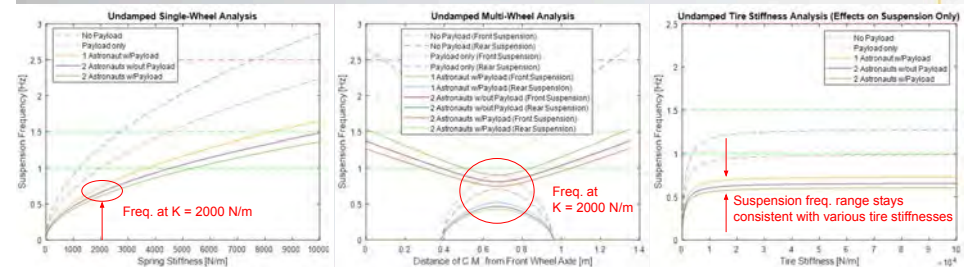

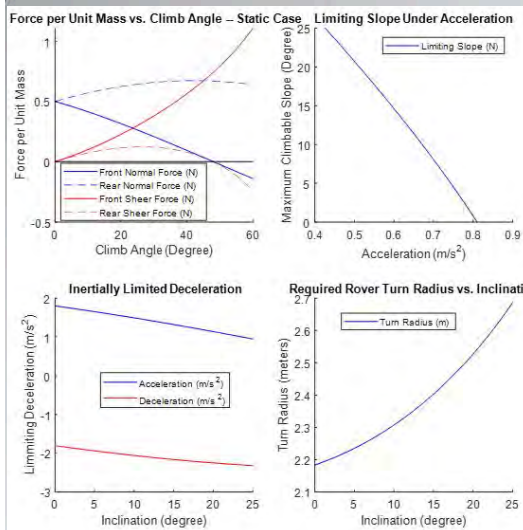

Stability

C.M. at geometric center

Parameter	Value	Unit
Max slope for positive front normal force	48.1	deg
Max slope for positive rear shear force	48.1	deg
Acceleration Limit at 20 deg slope	0.51	m/s ²
Achievable Acceleration at 20 deg slope	1.14	m/s ²
Limiting Slope for Acceleration	25	deg
Achievable Deceleration at 20 deg slope	-2.25	m/s ²
Required Turning Radius (4 m/s on 20 deg slope)	2.53	m

A. JAMES CLARK
SCHOOL OF ENGINEERING

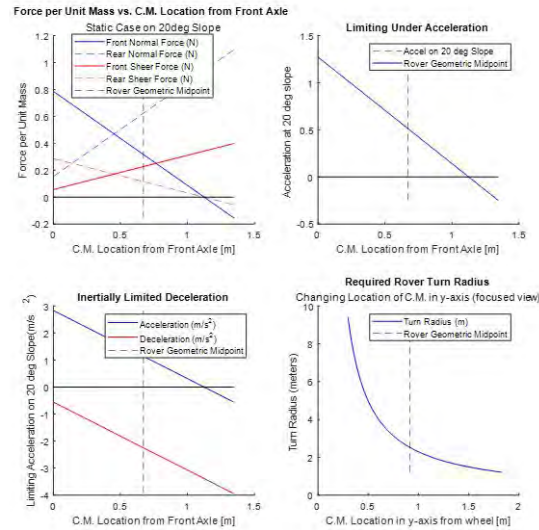

Stability

Shifting C.M.

Parameter	C.M. Location [m]
Positive front normal force and rear shear force	< 1.1 from front axle
Positive acceleration from static on 20 deg slope	< 1.1 from front axle
Maximum positive acceleration on 20 deg slope	< 1.1 from front axle

- Deceleration maximizes when C.M. is shifted behind geometric center
- Turn radius is reduced C.M. is shifted in the opposite direction of the turn

A. JAMES CLARK
SCHOOL OF ENGINEERING

Communicaitons

A. JAMES CLARK
SCHOOL OF ENGINEERING

Sensors

Cameras:

- Hi-Def
- Star Tracking

IMU

Encoders

LIDAR

Star Tracker Celestial Localization^[3]:

- Star Tracker Camera
- Inclinometer

https://www.geographyrealm.com/wp-content/uploads/2020/02/johnsons_reef_lidar.png
 Sigel and Wettergreen
 [3]

A. JAMES CLARK
SCHOOL OF ENGINEERING

Autonomy

3 Autonomous Modes:

- Unmanned: Receives objectives from base and can navigate towards goals and execute commands
- Manned: Analyzes the environment and prevents moving into hazards
- Remote: Tracks astronaut's position and follows close by



A. JAMES CLARK
SCHOOL OF ENGINEERING

57

Autonomy

Mapping:

- LIDAR detect objects and slopes
- Classifies the difficulty of climbing obstacle/slope

Path Planning

- Time limited RRT* using power as the cost-to-goal heuristic
- Velocity at a point is chosen to attempt to optimize power efficiency

<https://2.bp.blogspot.com/-mSRt46erWfU/VpBd7UdKKxI/AAAAAAABxo/N2noHicXTac/s1600/Untitled.jpg>

A. JAMES CLARK
SCHOOL OF ENGINEERING

58

Autonomous Contingencies

Return Trip:

- Remembers waypoints to follow back to base
- Uses same A* path planning between waypoints

Rollover Protection

- Classifies the difficulty of climbing obstacle/slope
- Prevents drivers from driving into hazardous locations

A. JAMES CLARK
SCHOOL OF ENGINEERING

59

Mass Budget

Mass Estimate (kg)			
Chassis	20.8	Drivetrain (total)	17.3
Wheel & Hub (total)	50.7	Sensors/Other	56.27
Motors (total)	9.88	Communications	7.70
Suspension (total)	8.80	Seat	10.08
Steering (total)	5.15		

Total Mass Estimate

186.68 kg

A. JAMES CLARK
SCHOOL OF ENGINEERING

60

Power Budget [W]

Component	1 Astronaut Drive	1 Astronaut walking being trailed by rover	1 astronaut driving 1 astronaut walking	Rover autonomously driving (path planning)	Rover autonomously Collecting Samples	Rover remotely controlled (via earth)	2 Astronauts riving with payload	2 Astronauts Driving without payload
Steering Motors	6	6	6	6	6	6	6	6
IMUs	12	12	12	12	12	12	12	12
LIDAR	8	8	8	8	8	8	8	8
Pulse code modulation encode	5	5	5	5	5	5	5	5
Robotic Manipulator	-	70	70	-	-	-	-	-
Data Management	20	20	20	20	20	20	20	20
Drivetrain	290.6	416.8	416.8	231.2	231.2	231.2	483.7	543.1
PLSS	50	50	-	-	-	-	50	-
Communications	46	46	46	46	46	46	46	46
Star Tracking	2	2	2	2	2	2	2	2
MASTCAM	18	18	18	18	18	18	18	18
Total	458	654	604	348	348	348	651	660

Power System Specifications

Component	1 Astronaut Drive	1 Astronaut walking being trailed by rover	1 astronaut driving 1 astronaut walking	Rover autonomously driving (path planning)	Rover autonomously Collecting Samples	Rover remotely controlled (via earth)	2 Astronauts riving with payload	2 Astronauts Driving without payload
Apply Battery charge up efficiency	503	719	664	383	383	383	716	726
Apply battery discharge efficiency	528	755	697	402	402	402	751	762
Battery Specific Energy [W-hrs/kg]	98	98	98	98	98	98	98	98
Determine necessary battery size [kg]	5.3924	7.7052	7.1159	4.1030	4.1030	4.1030	7.6679	7.7787
Mass Battery [kg]	2.5	2.5	2.5	2.5	2.5	2.5	2.5	2.5
Num batteries	3	4	3	2	2	2	4	4
Total Battery Mass [kg]	7.5	10	7.5	5	5	5	10	10
Solar Constant [W/m ²]	1367	1367	1367	1367	1367	1367	1367	1367
Efficiency	30%	30%	30%	30%	30%	30%	30%	30%
Area array [m ²] * Power	1.289	1.841	1.700	0.980	0.980	0.980	1.832	1.859
Solar Array Specific Power [W/kg]	220	220	220	220	220	220	220	220
Mass array (1/performance) [kg] * Power	2.402	3.432	3.170	1.828	1.828	1.828	3.416	3.465

Power System Mass Budget

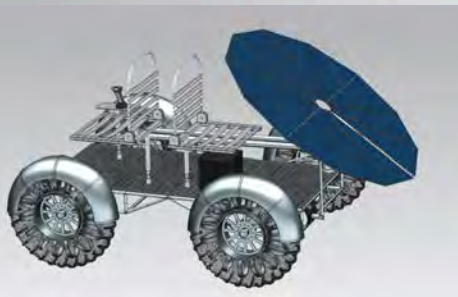

Power Mass Estimate (kg)*	
Batteries	10
Solar Array	3.5
Regulator/Converters	0.13
Wiring	0.72

*included in 'other' above
 Batteries- EaglePicher Space Cell SLC-16050 Lithium-Ion Cells, 2.5Kg, 245Wh storage per battery BOL
 Solar Array - Northrop Grumman UltraFlex with triple junction Solar Cells (30% efficient developed by Shanghai YIM Space Power Sources

Cost Estimate

Cost Estimate

Bibliography

- [1] Ueura, Keiji and R. Slatter. "ACTUATORS: Development of the harmonic drive gear for space applications." (1999).
- [2] Heißing B., Ersoy M. (2011) Ride Comfort and NVH. In: Heißing B., Ersoy M. (eds) Chassis Handbook. Vieweg+Teubner. https://doi.org/10.1007/978-3-8348-9789-3_5
- [3] D. A. Sigel and D. Wettergreen, "Star tracker celestial localization system for a lunar rover," 2007 IEEE/RSJ International Conference on Intelligent Robots and Systems, San Diego, CA, 2007, pp. 2851-2856, doi: 10.1109/IROS.2007.4399510.

ROCI

Rover for Operations support, Cargo, and Investigations

ENAE 788X

Aalay Patel
James Winsley

1 |

Outline

- Introduction
- Baseball Card
- Requirements
- Concepts Explored
- Design Evolution
- Design Details
- Operations
- Conclusion
- References
- Backup Slides

2 |

Introduction

- ROCI was designed to support Astronaut operations on the Moon
- ROCI will:
 - Be able to operate autonomously
 - Transport Astronauts and Cargo
 - Support Disembarked Astronauts
 - Have a sortie endurance of 8 hours
 - Travel 54 km on a single battery charge

3 |

ROCI



Specifications
Length: 2.8 m
Width: 1.8 m
Height: 1.1 m
Ground Clearance: 0.4 m

Personnel/Payload
Configurations:
1. Rover Only
2. 1 Astronaut and 80 kg of Cargo
3. 2 Astronauts

Rover for Operations support, Cargo, and Investigations is a rover that will support manned operations on the Moon. It is capable of operating solo or transporting Astronauts and Cargo. It is equipped with a solar array to minimize the need for recharge power from the base during Lunar Day. In an emergency, the Solar Array and Cargo Module can be detached to allow the second seat to be folded up to carry a second astronaut.

Mass Budget	Mass (kg)
Mass Used	154.9
Mass Limit	250
Mass Remaining	85.1
% Margin	34%
Nominal Configuration Statistics	
Flat Terrain Acceleration	0.38 m/s ²
0 to 4 m/s Time	10.5 Seconds
Distance Traveled to get to 4 m/s	21 m
Sortie Statistics	
Sortie Duration	8 Hours
Maximum Speed	4 m/s
Steering	Turn on a Point
Suspension	Independent Double Wishbone

4 |

Requirements

Ref Number	Requirement	Slide Numbers	Requirement Covered Summary
L1-1	Rover shall have a maximum operating speed of at least 4 m/sec on level, flat terrain.	37, 38, 66, 72, 88	The wheels are sized to provide positive drawbar pull on flat surfaces and motors are sized to meet the 4 m/s speed requirement
L1-2	Rover shall be designed to accommodate a 0.3 meter obstacle at minimal velocity.	33, 58, 66, 72, 82	The wheels are sized to climb over 0.3 meter obstacles.
L1-3	Rover shall be designed to accommodate a 0.1 m obstacle at a velocity of 2.5 m/sec.	33, 58, 66, 72, 82	The wheels are sized to handle 0.3 meter obstacles and motors are sized to meet the 2.5 m/s speed requirement.
L1-4	Rover shall be designed to safely accommodate a 20° slope in any direction at a speed of at least 1 m/sec and including the ability to start and stop.	37, 38, 39, 49, 52, 66, 82	The wheels will provide positive drawbar pull and the motors are sized to provide sufficient torque for the wheel's maximum tractive force. The wheels tractive force is sufficient to provide the required wheel thrust to meet static requirements when parked on a slope.

5 |

Requirements

Ref Number	Requirement	Slide Numbers	Requirement Covered Summary
L1-5	The rover shall have a nominal sortie range of 54 km at an average speed of 2.5 m/sec.	39, 66, 77, 79, 82	Batteries are sized to provide a 54 km sortie range traveling at 2.5 m/s.
L1-6	Rover shall be capable of carrying one 170 kg EVA crew and 80 kg of assorted payload in nominal conditions.	23, 82	The rover is designed to carry an EVA Crew member with cargo.
L1-7	Payload may be modeled as a 0.25 m ³ box	18, 23	The payload box is accommodated in the design.
L1-8	Rover shall be capable of also carrying a second 170 kg EVA crew in a contingency situation. Payload may be jettisoned if design permits.	23, 38, 39, 66, 82	The rover is capable of transporting a second EVA Crew Member in a Contingency Situation.

6 |

Requirements

Ref Number	Requirement	Slide Numbers	Requirement Covered Summary
L1-9	Rover design shall incorporate roll-over protection for the crew and all required ingress/egress aids and crew restraints.	52	The rover is stable in all operating modes. Fault protection will be provided to prevent overturn conditions. Crew restraints are also provided.
L1-10	A nominal sortie shall be at least eight hours long.	77, 79, 82	The battery is sized to provide sufficient power for an eight hour sortie.
L1-11	Two rovers must be launched on a single CLPS lander.	25, 26, 49	The rover is sized to fit two to a CLIPS lander.
L1-12	A single rover shall mass ≤ 250 kg.	22	The current rover design's mass is within the mass requirements with a margin.

7 |

Requirements

Ref Number	Requirement	Slide Numbers	Requirement Covered Summary
L1-13	Rovers shall be developed in time to be used on the first Artemis landing mission.	78, 80	COTS components and currently available materials will be used.
L1-14	Rover shall be capable of operating indefinitely without crew present.	80, 82	Sensors, Autonomous Software, and Communications components will be added to allow the rover to operate without crew.
L1-15	Rover shall be capable of being controlled directly, remotely, or automated.	85	Communications systems will allow remote control. Sensors and software will allow autonomous operations. Crew interfaces will allow for direct control.
L1-16	Rover shall be capable of following an astronaut, following an astronaut's path, or autonomous path planning between waypoints.	85	Cameras will recognize reference tags on astronauts to allow for following. A computer, LIDAR, and cameras will allow for autonomous navigation.

8 |

Requirements

Ref Number	Requirement	Slide Numbers	Requirement Covered Summary
L1-17	The Rover will be capable of operating during any part of the day night cycle and at any latitude.	80	Lights will be added to allow for operations in the night cycle. A solar array will allow for remote charging during the day cycle.

9 |

Concepts Explored: ROCI Modular Wheel



10 |

Concepts Explored: Trades and Decisions Overview

- Mobility Design Decision
 - Options: Wheels, Tracks, or Legs
 - Wheels were selected
- Wheel Width, Diameter, and Number Trade Study
 - Wheel Number Options: 4, 6, or 8
 - 4 Wheels were selected
- Wheel Width and Diameter Decision
 - Diameter Range: 0.3 m to 1 m and Width Range 0.05 m to 0.3 m
 - 0.8 m Diameter and 0.1 m Width wheels were selected

11 |

Concepts Explored: Trades and Decisions Overview

- Grousers Trade Study
 - Grouser Height Range : 1 cm to 10 cm
 - 30 4.5 cm Grousers were selected
- Suspension Design Decision
 - Spring Independent Suspension
- Steering Design Decision
 - Independent Steering with Turn on a Point Capability
- Solar Array
 - Options: Silicon, Single Junction GaAs, or Triple Junction GaAs
 - Triple Junction GaAs Selected

12 |

Design Evolution: Phase 1

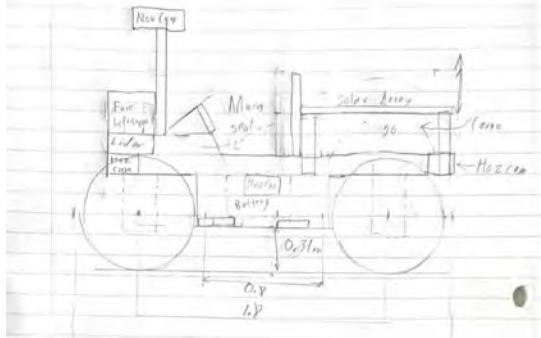

13 |

Design Evolution: Phase 2



14 |

ROCI Final Design

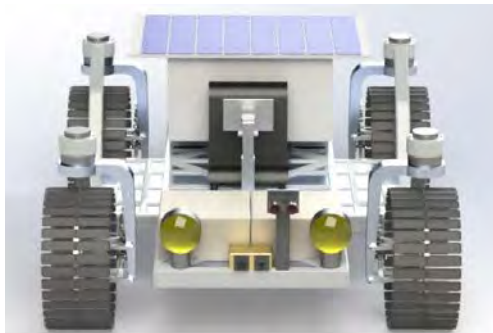

15 |

Design Overview

- ROCI Base Dimensions
- Design Wheel
- ROCI with the Design Wheels
- Mass Budget
- Configurations
- Size Restrictions



16 |

Design Overview



17 |

ROCI Base Dimensions

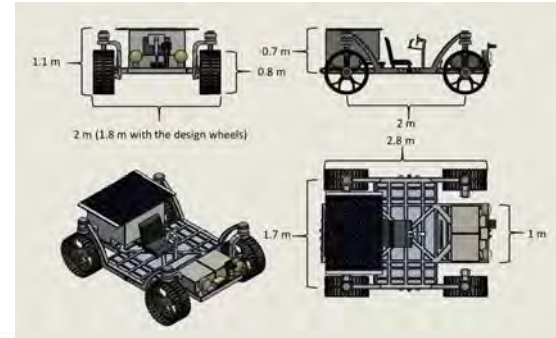

18 |

ROCI Base Dimensions

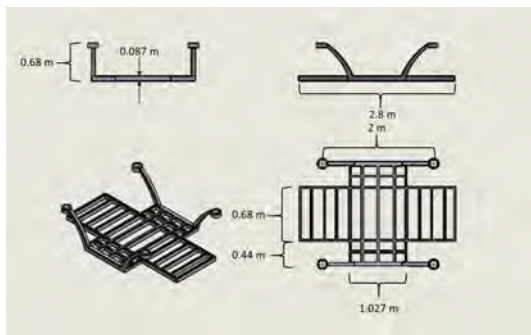

19 |

Design Wheel



20 |

ROCI with the Design Wheels

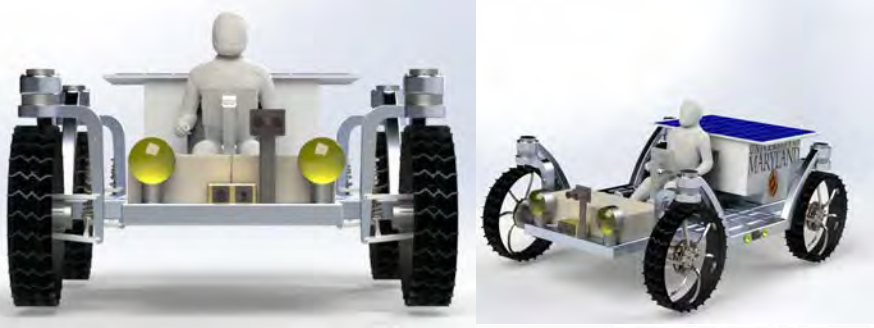

21 |

Design Overview: Mass Budget

Item	Mass (kg)
Structure/Chassis	65
Suspension and Wheels	24.8
HASCAMS	1.8 [6]
NAVCAMS	0.4 [6]
Battery	25.9
Driver Motors and Harmonic Drive	7.6
Steering Motors	10.4
Solar Array	1.6
Total Mass	163.5
Margin	35%

- Mass Budget is below the 250 kg allocation for a CLIPS Lander with a margin.
 - Satisfies Requirement: L1-12, A single rover shall mass less than 250 kg.

22 |

Design Overview: Configurations

- The Rover will have three configurations
 - Configuration 1: Dry Mass Configuration
 - Consists of just the Rover
 - Configuration 2: Nominal Configuration
 - Consists of the Rover, One EVA Crew, and One Payload Module
 - Configuration 3: Emergency Configuration
 - Consists of the Rover and Two EVA Crew
 - To switch to this configuration, the Payload Module and Solar Array are removed and the Second Seat is folded up to carry the Second EVA Crew back to base.
- These configurations will accommodate the following requirements:
 - L1-6: Rover shall be capable of carrying one 170 kg EVA Crew and 80 kg of assorted payload in nominal conditions
 - L1-8: Rover shall be capable of carrying a second 170 kg EVA Crew in a contingency configuration. Payload maybe jettisoned if design permits.



23 |

Configurations ROCI Emergency Configuration



24 |

Size Restriction

- To meet requirement L1-11, two rovers need to fit in a CLIPS Lander and the CLIPS lander has to fit within a Falcon 9 Payload Bay

Falcon 9 Payload Bay [1]

Size Restriction

- Two ROCI Rovers will fit in the CLIPS Bay in a stacked configuration.



Design Details

- Terra Mechanics and Wheel Design
- Stability and Breaking
- Suspension and Obstacles
- Chassis
- Motor and Gearing
- Power Systems
- Performance Summary

Terra Mechanics and Wheel Design

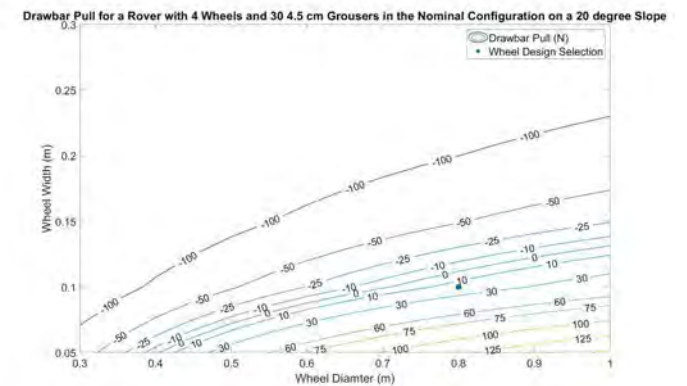

Terra Mechanics and Wheel Design

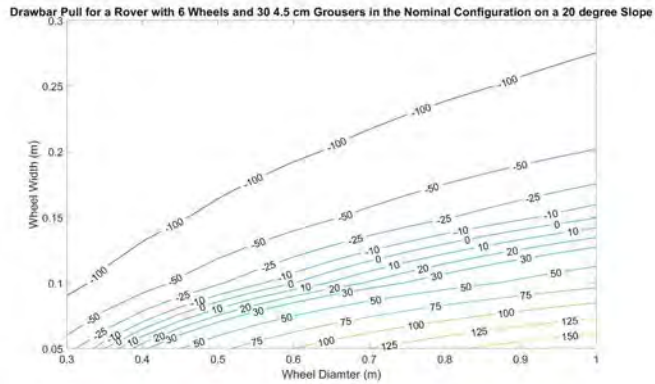

29 |

Terra Mechanics and Wheel Design

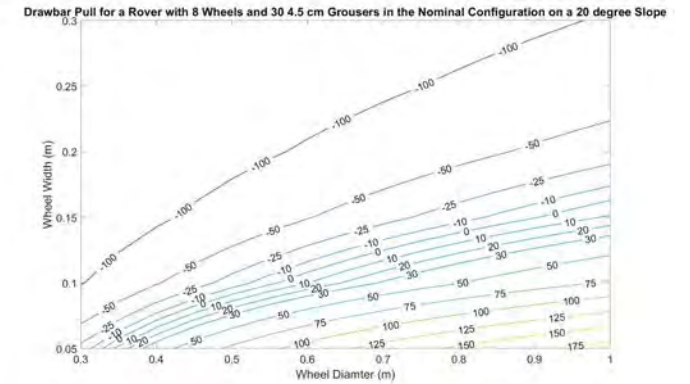

30 |

Terra Mechanics and Wheel Design

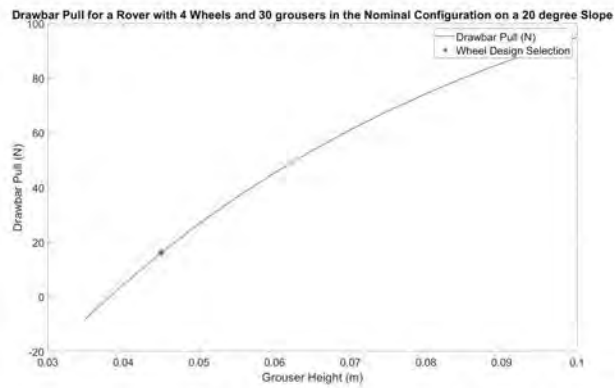

31 |

Terra Mechanics and Wheel Design

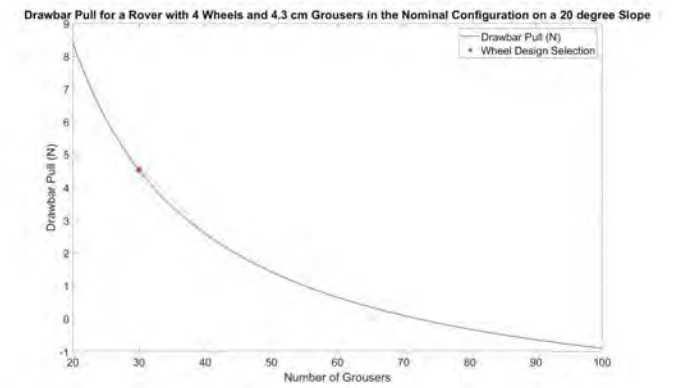

32 |

Terra Mechanics and Wheel Design

Configuration	Maximum Tractive Force Per Wheel (N) *	Torque Per Wheel (Nm) **	Bulldozing Resistance Per Wheel(N)	Compression Resistance per Wheel (N)	Gravitational Resistance (N) [Slope]	Rolling Resistance (N)	Drawbar Pull (N) [Slope]
Dry Mass	68.1	27.2	45.5	10.8	105.1	20.3	12.9 [15 deg]
Nominal	145.3	58.1	68.7	27.2	277.9	40.6	16.1 [20 deg] ***
Emergency	173.8	69.5	76.4	33.9	327.9	47.9	30.8 ***
Number of Wheels*	Diameter (m)	Width (m)	# of Grousers	Grouser Height (cm)			
4	0.8 ***	0.1	30	4.5			

* Initial Trade Study assumed equal weight distribution. A refined performance estimate with CG is on slide 76.

** Used for power estimates for sorties

*** Supports L1-2 and L1-3 Requirements

33 |



Terramechanics and Wheel Design: Slopes

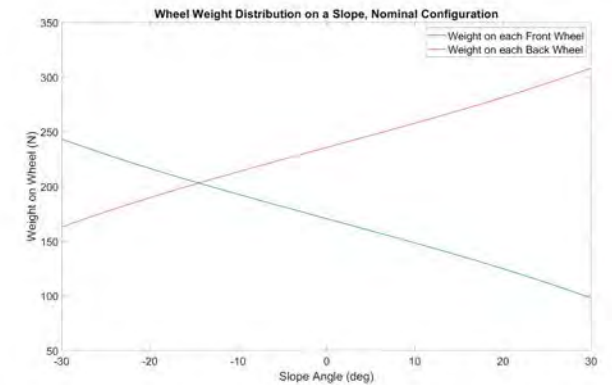

34 |

Terramechanics and Wheel Design: Slopes

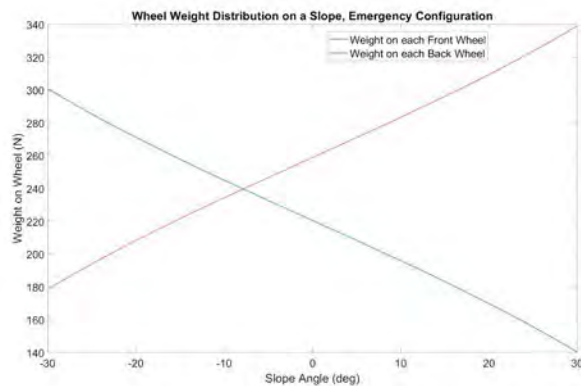

35 |

Terramechanics and Wheel Design: Slopes

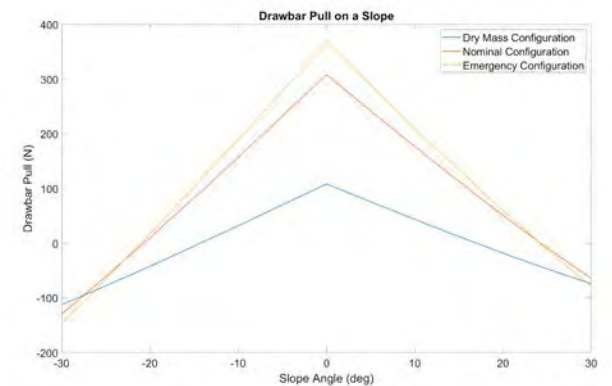

36 |

Terramechanics and Wheel Design: Slopes

Configuration	Slope	Front Wheels		Back Wheels		Acceleration			
		Tractive Force per Wheel (N)	Torque Per Wheel (Nm)	Tractive Force per Wheel (N)	Torque Per Wheel (Nm)	Drawbar Pull (N)	Acceleration (m/s ²)	Time to Max Speed (s) [Max Speed (m/s)]	Distance Traveled to get to Max Speed (m)
Dry Mass	15°	69.1	27.6	67.2	26.9	12.3	0.03	33 [1 m/s]	17
	0°	83.2	33.3	53.3	21.3	108.2 **	0.26	15 [4 m/s] **	30
	-10°	92.6	37.0	44.4	17.8	32.0	0.079	12.7 [1 m/s]	7
Nominal	20°	85.4	24.1	206.8	82.7	51.0 *	0.063	15.9 [1 m/s] *	8
	0°	120.1	48.1	170.6	68.2	308.1 **	0.38	10.5 [4 m/s] **	21
	-20°	155.6	62.3	134.9	53.9	10.4 *	0.012	77.9 [1 m/s] *	39

* Note: Supports Requirement L1-4.

** Note: Supports Requirement L1-1

Terramechanics and Wheel Design: Slopes

Configuration	Slope	Front Wheels		Back Wheels		Acceleration			
		Tractive Force per Wheel (N)	Torque Per Wheel (Nm)	Tractive Force per Wheel (N)	Torque Per Wheel (Nm)	Drawbar Pull (N)	Acceleration (m/s ²)	Time to Max Speed (s) [Max Speed (m/s)]	Distance Traveled to get to Max Speed (m)
Emergency	20°	119.6	47.8	229.1	91.6	60.2 *	0.063	15.9 [1 m/s] *	8
	0°	158.8	63.5	188.9	75.6	366.7 **	0.38	10.5 [4 m/s] **	21
	-20°	198.6	79.4	149.3	59.7	17.8 *	0.018	53.9 [1 m/s] *	27

* Note: Supports Requirement L1-4.

** Note: Supports Requirement L1-1

*** Note: Supports Requirement L1-8

Terramechanics and Wheel Design: Slopes

- Wheels are sized to accommodate 20° slopes with a positive drawbar pull and will accommodate the following requirement
 - L1-4: Accommodate a 20° slope with a speed of 1 m/s with the ability to start and stop.
 - The Rover has a positive drawbar pull on slopes and the tractive force per wheel is sufficient to meet the wheel thrust needed for stability on slopes (See Slide XX in Backup Slides)
 - L1-5: The rover shall be capable of carrying one 170 kg EVA crew and 80 kg of assorted payload in nominal conditions
 - L1-8: The rover shall be capable of carrying a second EVA crew. Payload may be jettisoned if design permits

Stability: ROCI Center of Gravity

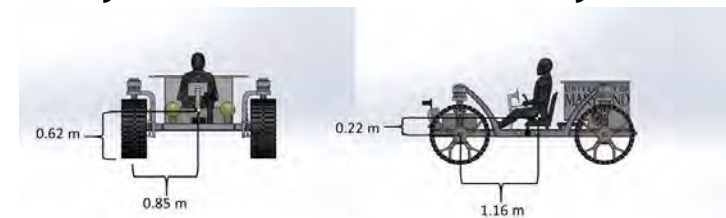

- Rover + Astronaut + Payload Configuration:
 - 0.62 m vertical from the ground (0.22 m from the center of the front axle) and 1.16 m from the center of the front axle horizontally.
- Rover + 2 Astronaut Configuration:
 - 0.58 m vertical from the ground (0.18 m from the center line of the front axle) and 1.08 m from the center of the front axle horizontally.
- Rover Configuration:
 - 0.61 m vertical from the ground (0.21 m from the center line of the front axle) and 1.1 m from the center of the front axle horizontally.

Stability and Breaking: Slopes and Roll Over

41 |

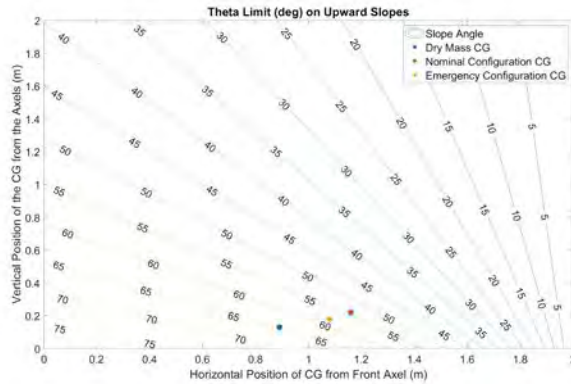

Stability and Breaking: Slopes and Roll Over

42 |

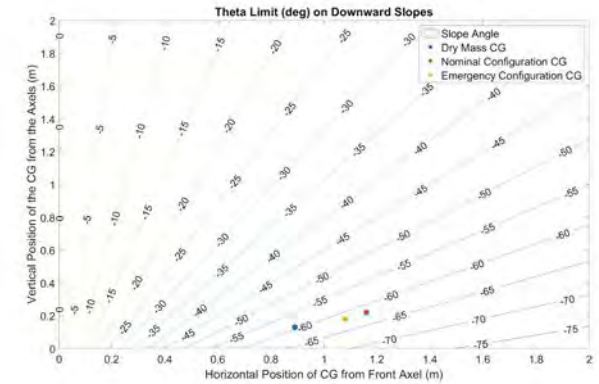

Stability and Breaking: Slopes and Roll Over

43 |

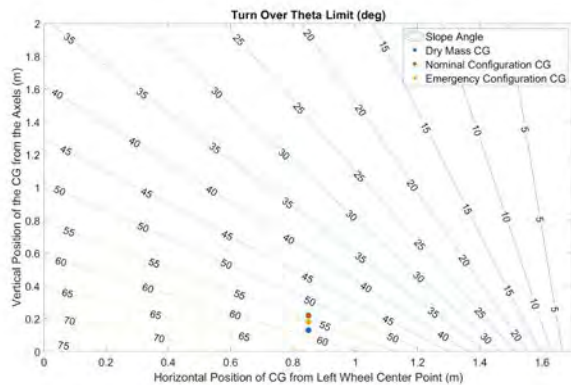

Stability and Breaking: Acceleration

44 |

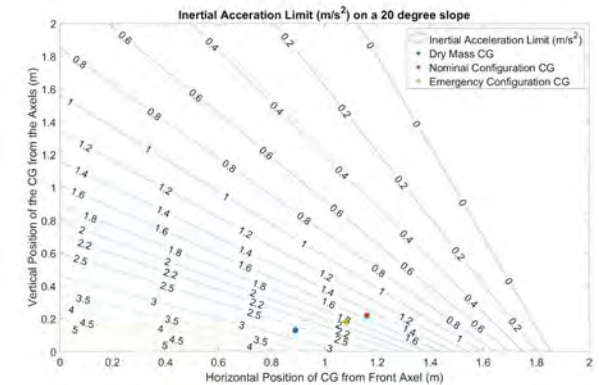

Stability and Breaking: Acceleration

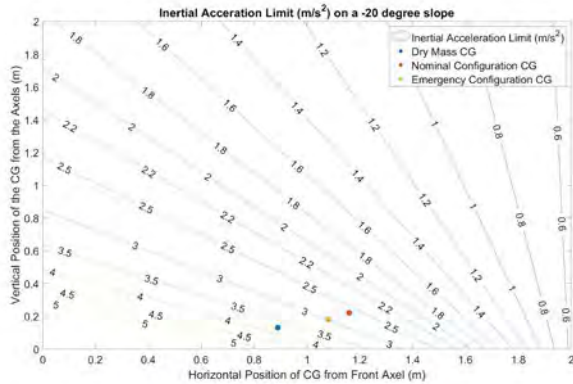

45 |

Stability and Breaking: Deceleration

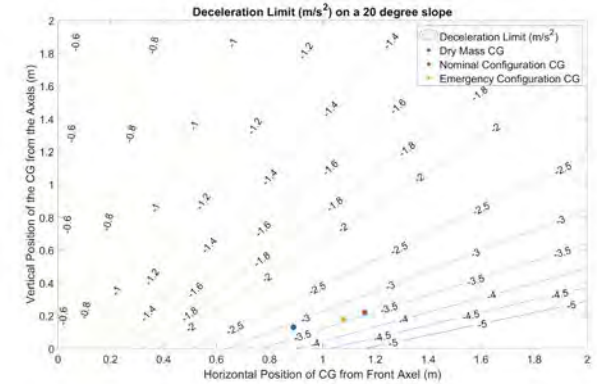

46 |

Stability and Breaking: Deceleration

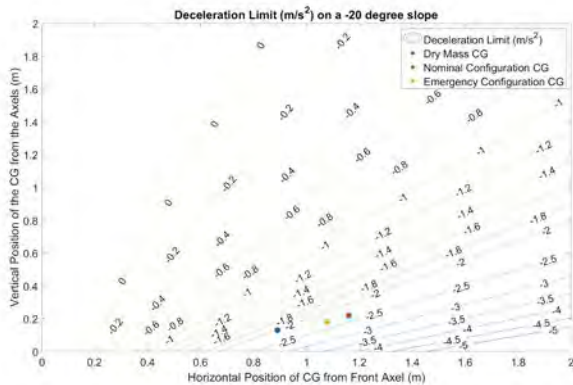

47 |

Stability and Breaking: Pitch Over

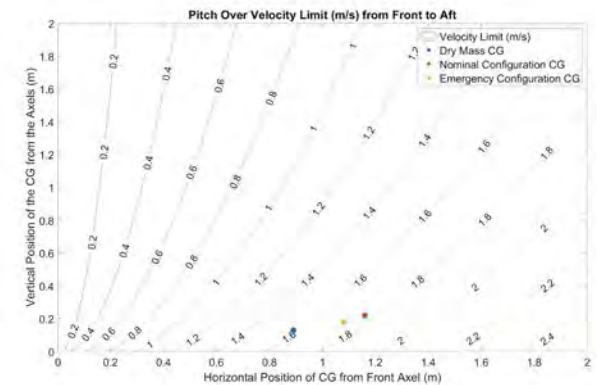

48 |

Stability and Breaking: Slope, Turn Over, Turning Radius, and Pitch Over Limits

	Up Slope Limit (deg) *	Down Slope Limit (deg) *	Turn Over Limit (deg) *	Pitch Over Velocity Limit (m/s)
Dry	64.4	-59.2 **	58.0	1.5
Nominal	53.5	-61.8	53.8	1.7
Emergency	57.7	-61.7	55.6	1.7

* Note: Rover will be stable on a 20° slope which supports Requirement L1-4.

** Note: The Rover will be stable when deploying via rolling down a 30° ramp from the CLIPS vehicle supporting Requirement L1-11.

Stability and Breaking: Slope, Turn Over, Turning Radius, and Pitch Over Limits

Configuration	Turning Radius Limits (m) on Flat Surface		Turning Radius on a 20 degree Slope
	4 (m/s)	2.5 (m/s)	1 (m/s)
Dry	6.1	2.4	0.52
Nominal	7.2	2.8	0.65
Emergency	6.7	2.6	0.59

Stability and Breaking: Acceleration and Deceleration Limits

Configuration	Flat Surface		20° Slope		-20° Slope	
	Inertial Acceleration Limit (m/s ²)	Deceleration Limit	Inertial Acceleration Limit (m/s ²)	Deceleration Limit (m/s ²)	Inertial Acceleration Limit (m/s ²)	Deceleration Limit (m/s ²)
Dry	3.4	-2.7	2.6	-3.1	3.7	-2.0
Nominal	2.2	-3.0	1.5	-3.4	2.6	-2.3
Emergency	2.5	-3.0	1.8	-3.3	2.9	-2.2

Stability and Breaking

- The rover's stability limits on slopes are in excess of 20° will accommodate the following requirement:
 - Supports the Slope Requirement of L1-4 and Protection Requirement L1-9.
- Software Fault Protection logic will include protections for the vehicle to not exceed stability limits.
 - Supports Roll Over Protection Requirement in L1-9.

Stability and Breaking

- ROCI has a friction brake disc and caliper packaged in the wheel with the motor to brake the rover.
- Braking is initiated when the controller is pulled backwards in manual mode and autonomously in the exploration mode.
- This operation deenergizes the drive motor and forces brake shoes against a brake disc that stops the rotation of the wheel hub.
- Equal braking force for the left and right wheels is affected by routing the command through the main rover computer.

Disc Brake [7]

Suspension and Obstacles: Suspension Design Decision

Type	Advantages	Disadvantages
Rocker-Bogie	<ul style="list-style-type: none"> • Allows to climb over high obstacles, while keeping all wheels in contact with the ground. • Rover can traverse terrains where the right and left rockers go over different type of obstacles. 	<ul style="list-style-type: none"> • This is only true at lower operational speeds. • Highly unstable at high speeds. At high speeds it experiences head on collision of wheels with obstacles. This would cause an impulsive force to act on front wheels.
Independent Suspension	<ul style="list-style-type: none"> • The most widely used front suspension system. • Legacy advantage • Better handling and cornering • More ride comfort for manned mission 	<ul style="list-style-type: none"> • The independent motion of each wheel on an uneven surface results in uneven wear. • Complex design compared to Rocker-Bogie suspension.

Suspension and Obstacles: Suspension



Individual Double Wishbone Suspension

Suspension and Obstacles: Suspension



- A four wheel independent suspension allows each wheel to move up and down independently from the rest of the suspension. This means that all four of the vehicle's wheels will always be in contact with the ground.

Suspension and Obstacles

- Active suspension control through a PID controller resulting in less than 10 % overshoot.

Spring constant of suspension system	80000 N/m
Spring constant of wheel and tire	50000 N/m
Damping constant of suspension system	1500 Ns/m
Damping constant of wheel and tire	350 Ns/m

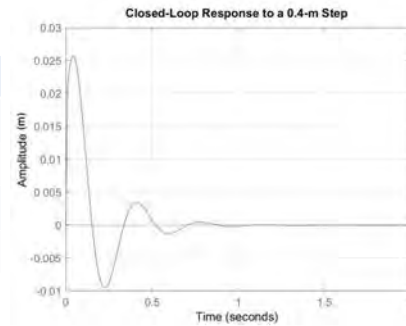

57 |

Suspension and Obstacles

Configuration	Obstacle Height and Location	Front Right Wheel Weight on Wheel [N]	Rear Right Wheel Weight on Wheel [N]	Front Left Wheel Weight on Wheel [N]	Rear Left Wheel Weight on Wheel [N]	Max Wheel Tractive Force Encountered [N]	Max Torque from Max Wheel Tractive Force [Nm]	Drawbar Pull [N] *
Nominal	0.3 m under Front Right Wheel	263	111	49	377	320	128	390
	0.1 m under Front Right Wheel	197	193	127	283	236	94	382
	0.3 m under Rear Right Wheel	41	333	307	119	280	112	385
	0.1 m under Rear Right Wheel	123	266	214	197	220	88	379

* Note: Supports: L1-2 and L1-3.

58 |

Suspension and Obstacles

Configuration	Obstacle Height and Location	Front Right Wheel Weight on Wheel [N]	Rear Right Wheel Weight on Wheel [N]	Front Left Wheel Weight on Wheel [N]	Rear Left Wheel Weight on Wheel [N]	Max Wheel Tractive Force Encountered [N]	Max Torque from Max Wheel Tractive Force [Nm]	Drawbar Pull [N]
Emergency	0.3 under Front Right Wheel	308	133	99	404	346	138	459
	0.1 under Front Right Wheel	247	215	177	305	256	102	454
	0.3 under Rear Right Wheel	91	355	357	141	303	121	451
	0.1 under Rear Right Wheel	120	341	211	272	288	115	474

* Note: Supports: L1-2 and L1-3.

59 |

Chassis: Analysis at 1g (Earth)

Study name: Static: 10 (Earth)
Plot type: Static: nodal stress (stress)

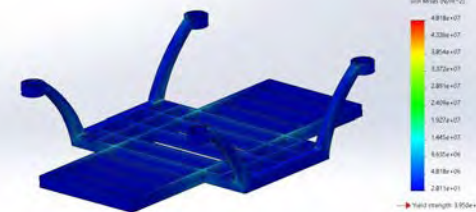

Material	Al 2219 -T87
Mass	64.2 kg
Density	2840 kg/m ³
Young's Modulus	72 GPa
Shear Modulus	27 GPa
Yield Strength	395 MPa
Tensile Strength	475 MPa
Safety Factor (Static Load)	10

60 |

Chassis: Analysis at 1g (Earth)

Study name: Static 10-Default-1
Plot type: Static displacement/Displacement

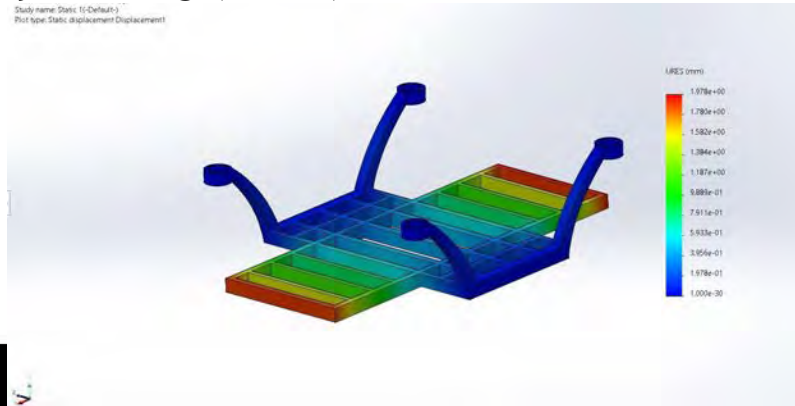

61 |

Chassis: Analysis at 1g (Earth)

Plot type: Factor of Safety Factor of Safety
Criterion: Max Normal Stress
Factor of safety distribution Min FOS = 10

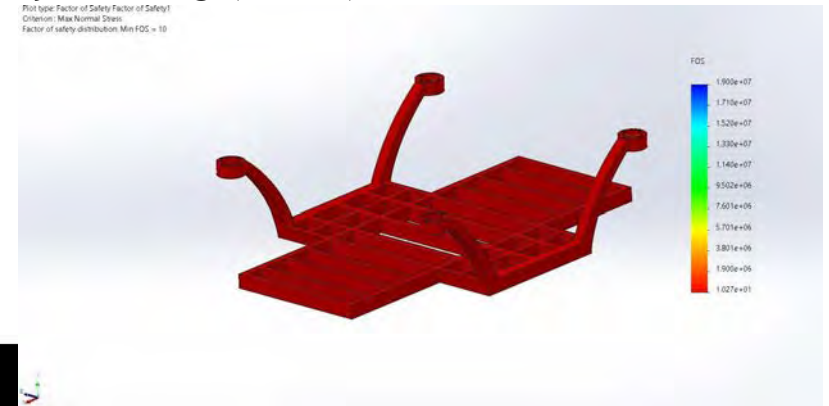

62 |

Chassis: Analysis at 10g (Earth)

Plot type: Static nodal stress/ Stress
Deformation scale: 14.2636

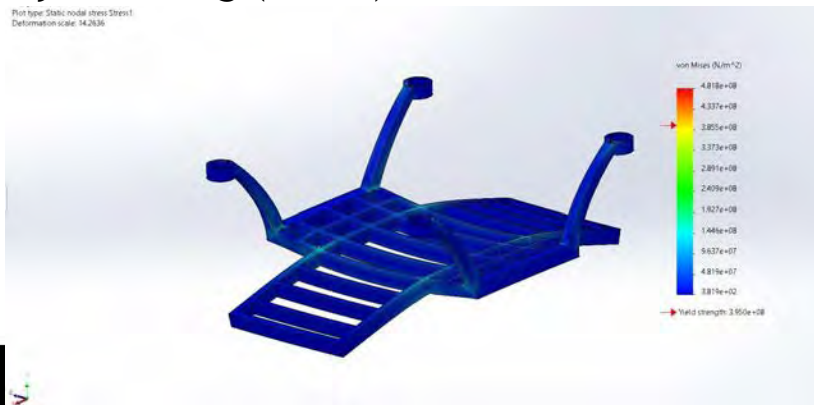

63 |

Chassis: Analysis at 10g (Earth)

Plot type: Static displacement/Displacement
Deformation scale: 14.2636

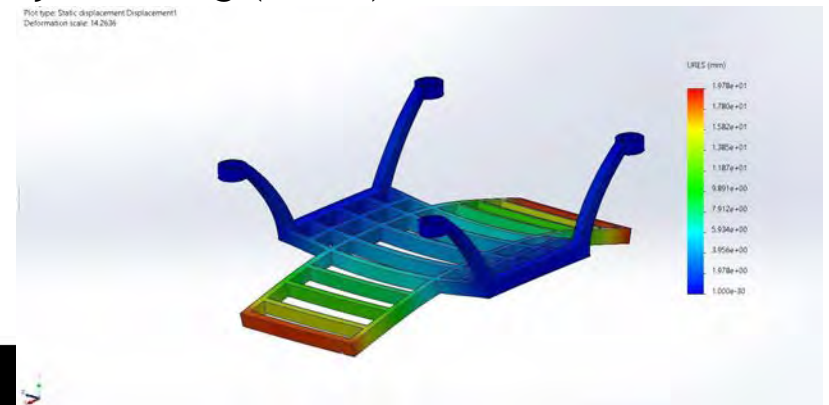

64 |

Chassis: Analysis at 10g (Earth)

Criterion: Max Normal Stress
Factor of safety distribution Min FOS = 1

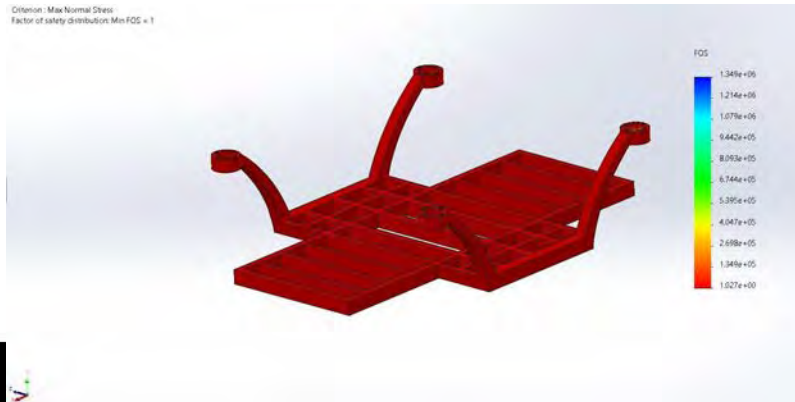

65 |

Motors and Gearing: Drive Motor Requirements

	Max Torque (Nm)	Origin
Slopes	91.6	Emergency Configuration
Obstacles	138.0 *	Back Left Wheel in the Emergency Configuration
Speed Over a 0.1 m Obstacle	Sortie Cruising Speed	Max Speed
2.5 m/s	2.5 m/s	4 m/s *

* Note: Motors will be sized to meet Requirements L1-1, L1-2, L1-3, L1-4, L1-5, L1-6, and L1-8.

66 |

Motors and Gearing: Steering

- The Rover will rotate on a spot to turn.
- Steering Power:
 - Wheel Velocity of 1 m/s
 - Dry Mass Configuration: 81.2 W
 - Nominal Mass Configuration: 162.5 W
 - Emergency Mass Configuration: 181.8 W
- Pskid/Psteer = 4.7
- Estimated Steering Torque: 10.8 Nm

67 |

Motors and Gearing: Drive Gearing Trade Study

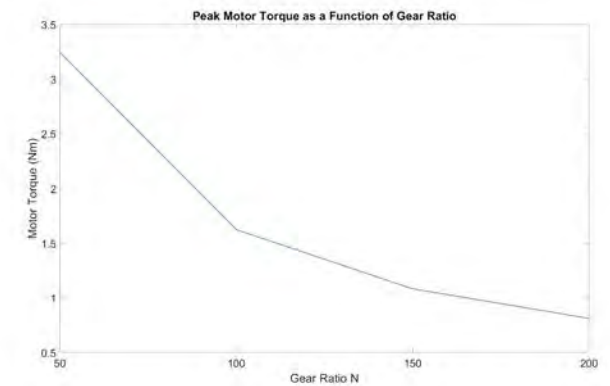

68 |

Motors and Gearing: Drive Gearing Trade Study

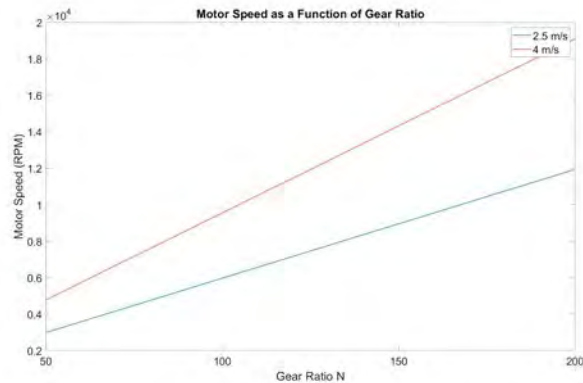

69 |

Motors and Gearing: Drive Gearing Trade Study

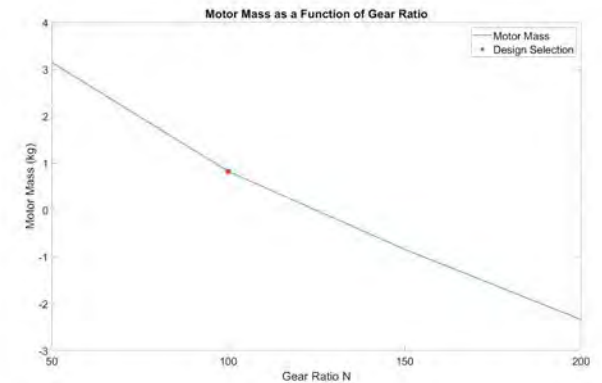

70 |

Motors and Gearing: Specifications

- Drive Motor Mass: 0.8 kg
 - Gear Ratio: 50
 - Peak Torque: 138 Nm
 - Peak Velocity: 4 m/s
- Harmonic Drive Mass: 1.1 kg
 - Peak Torque: 138 Nm
- Steering Motor and Harmonic Drive Mass: 2.6 kg
 - Max Weight on Wheel: 404 N (Back Left Wheel when the Front Right Wheel is on a 0.3 m Obstacle)
 - Estimated Steering Torque: 10.8 Nm
 - Estimated RPM: 4 RPS

71 |

Motors and Gearing: Steering



72 |

Motors and Gearing: Steering

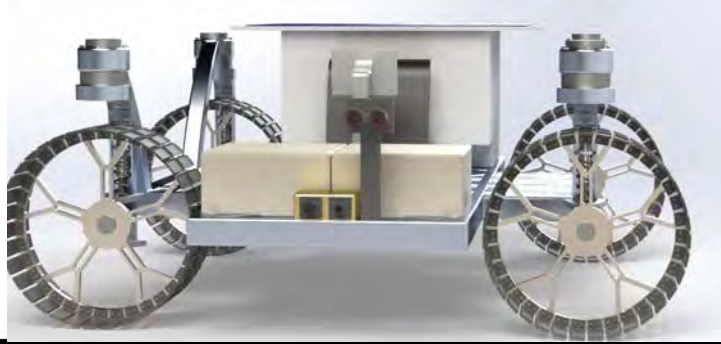

73 |

Motors and Gearing: ROCI Turning Maneuver

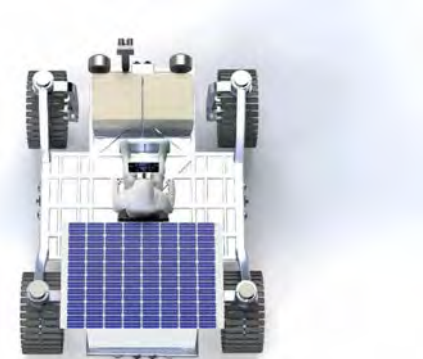

74 |

Motors and Gearing: Specifications

- By setting the peak motor speed to handle 4 m/s and the peak torque 441 Nm the following requirements are satisfied:
 - L1-1: Maximum Operating Speed must be 4 m/s on Flat Terrain.
 - Motor maximum speed will accommodate 4 m/s.
 - Peak torque is in excess of the torque for the tractive forces to be encountered on flat terrain
 - L1-2: Accommodate 0.3 m obstacles at minimum velocity
 - Motor maximum speed is sized in excess of a minimum velocity.
 - Peak motor torque is sized in excess of expected torques on 0.1 m obstacles
 - L1-3: Accommodate 0.1 m obstacles at 2.5 m/s
 - Motor maximum speed is sized to accommodate speeds in excess of 2.5 m/s
 - Peak motor torque is sized in excess of expected torques on 0.1 m obstacles
 - L1-4: Accommodate slopes of at least 20 degrees at a speed of 1 m/s with the ability to stop
 - Motor maximum speed is sized to accommodate speeds in excess of 1 m/s
 - Peak motor torque is sized in excess of expected torques on 20° slopes

75 |

Power Systems: Motor and Housekeeping Loads

Configuration	Motor Output (W) at 2.5 m/s ****	Motor Input Load (W) at 2.5 m/s *	Total (4 Wheels) Motor Input Load (W) at 2.5m/s
Dry Mass	31.9	35.4	141.6
Nominal	68.0	75.6	302.4
Emergency	81.4	90.4	361.6
CPU Loads (W) **	Communications (W)	LIDAR (W)	Total Housekeeping Loads (W) ***
36.8	8.5	10	55.8

* Note: A motor efficiency of 90% was used to estimate input loads.

** Note: Based on a primary input of 5.6 V and 6.7 A and an aux input of 3.3 V and 1 A. [3].

*** Note: These values will be used for battery sizing and time to recharge studies.

**** Note: Based on Torques from Wheel Sizing Tractive Forces on slide 33.

76 |

Power Systems: Sortie Power Profiles

- L1-5 Requires that the rover travels 54 km at an average speed of 2.5 m/s²
 - 2.5 m/s² -> 9 km/h
 - At 9 km/h, the rover can cover 54 km in 6 hours
 - Total motor load time will be applied for 6 hours
- L1-10 Requires a nominal sortie to last 8 hours
 - HK Loads will be applied for 8 hours
- Sortie Power Profiles
 - Dry Mass Sortie
 - Dry Mass Motor Load Time: 6 hours, HK Load Time: 8 hours
 - Nominal Config Sortie
 - Nominal Config Motor Load Time: 6 hours, HK Load Time: 8 hours
 - Emergency Config Sortie
 - Nominal Config Load Time: 3 hours, Emergency Load: 3 Hours, HK Load: 8 hours
 - Allow the Astronauts to return if an Emergency occurs 27 km out (return point for a sortie)

77 |

Power Systems: Cell Selection and Battery Specification

- A Single Saft battery consisting of VL51ES Li Ion Cells in a 8s3p configuration [2]
 - Single Battery Stats [2]
 - Wh Capacity: 4406.4 Wh
 - Nameplate Capacity: 153 Ah
 - Voltage: 28V
 - Dimensions: 21.6 cm x 32.4 cm x 22.2 cm
 - Mass: 25.9

SAFT VL51ES Li Ion Cell [2]

78 |

Power Systems: Battery usage used based on Sortie Type

- Dry Mass Sortie
 - Battery Capacity Used: 1568 Wh
 - Depth of Discharge (DoD) for the Sortie: 34.9% *
- Nominal Config Sortie
 - Battery Capacity Used: 2687 Wh
 - DoD for Sortie: 61.0% *
- Emergency Sortie
 - Battery Capacity Used: 2898 Wh
 - DoD for Sortie: 65.7% *
- Power Endurance while Parked at Night: 78 Hours, 58 Minutes

* Note: The battery will meet Requirements L1-5 and L1-10

Note: Equations and constants used to calculate these values and create the charts on the next two slides are in the backup slides

79 |

Power Systems: Solar Array Trade Study

Cell Technology	Efficiency	W Density	Mass Density
Silicon	14%	202.95 W/m ²	0.13 kg/m ²
Single Junction GaAs	18.5%	250.3 W/m ²	0.8 kg/m ²
Triple Junction GaAs	29.5%	399.1 W/m ²	0.8 kg/m ²

- Triple Junction GaAs Cells will be used for ROCI's Solar Array
 - While denser than Silicon Cells, Triple Junction GaAs Cells provide a great watt per square meter over the other two options.
- A Solar Array will support the day period requirement of L1-14 and L1-17.

80 |

Power Systems: Time to Charge

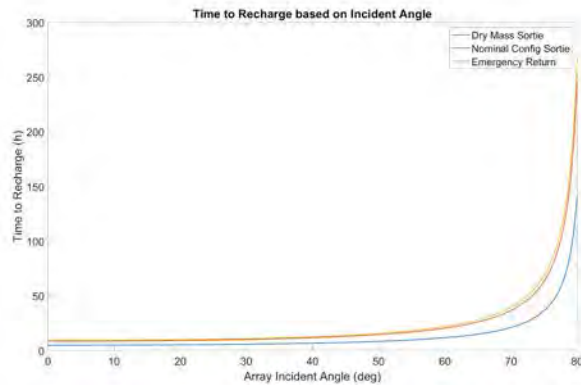
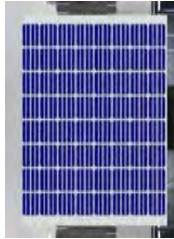

81 |

Performance Summary

- **Stability:**
 - The Rover is stable on 20° and 30° Slopes
 - Requirements Supported: L1-4, L1-9, and L1-11
- **Terrain Performance and Suspension:**
 - The Rover can navigate on open terrain and up and down 20° slopes at 4 m/s, climb 0.1 m obstacles at 1 m/s, and 0.3 m obstacles, while meeting crew and payload requirements.
 - Requirements Supported: L1-1, L1-2, L1-3, L1-4, L1-6, and L1-8
- **Motors:**
 - Motors are sized to handle speeds up to 4 m/s, all slope requirements, and obstacle climbing.
 - Requirements Supported: L1-1, L1-2, L1-3, L1-4, L1-5, L1-6, and L1-8
- **Power:**
 - The power system is designed to handle 8 hour sorties and a range of 54 km at a 2.5 m/s cruising speed with recharge capability via a solar array
 - Requirements Supported: L1-5, L1-10, and L1-14.

82 |

Operations

- Rover Modes
- Control and Navigation
 - Navigation Loop
 - Cameras
 - Sensors
 - Fault Protection
- Communications
- Computer
- Crew Systems
- Earth Testing Considerations

83 |

Operations: Rover Modes

- ROCI will have the following modes defined in its software
 - Deployment Mode
 - Diagnostic
 - Autonomous Mode
 - Solo
 - Assist
 - Manned Mode
 - Emergency Transport
 - Safe Mode
 - Park Mode
- Detailed Information on these modes will be in the Backup Slide Section.

84 |

Operations: Control and Navigation

- For Autonomous Operations:
 - The Rover will have Cameras and LIDAR to provide knowledge of its environment.
 - When supporting an EVA Crew Member, it will track and follow the EVA Crew via reference tags. The EVA Crew will issue voice commands to the rover. This will support requirement L1-16.
 - For Navigation:
 - Algorithms will be included to control the rover autonomously
 - Operator defined waypoints will be established
 - Communications will be maintained with both Mission Operations and the EVA Crew remotely
 - Operations Instructions will be sent from either Mission Operations or the EVA Crew
- For Manned Operations:
 - The following Crew Interfaces will be included:
 - A multifunction display will provide navigation assist and rover telemetry for the EVA Crew member
 - A joystick will be provided to control the rover. The joystick will be attached via a support structure to provide stability.
 - These interfaces will support the manned portion of Requirement L-15.
 - Constant communications will exist between the EVA Crew and Mission Operations.
- Fault Protection will be provided via on-board software to protect the Crew and Rover.

85 |

Control and Navigation: Navigation Loop

- To perform autonomous navigation, the following loop that is mentioned in reference 4 will be implemented in ROCI's flight software.
- This will support Requirement L1-14, L-15, and L-16
- Path Plans and Instructions will be provided by either EVA Crew or Mission Operations
- Scans will be provided by Lidar and Cameras

Navigation Loop for "Autonomous Over-the-Horizon Navigation" [4]

86 |

Control and Navigation: Sensors

- IMU(Inertial Measurement Unit)
 - It will provide 3-axis information on the rover's position (Attitude and Acceleration), which will enable it to make precise vertical, horizontal, and (yaw) movements when it's in autonomous mode. Will be used for rover navigation to support safe traverses and to estimate the degree of tilt the rover is experiencing on the surface.
- LiDAR (LiDAR + Vision based navigation)
 - The combined Vision + LiDAR based system, will involve combining vision system pixels with LiDAR voxels for simultaneous and faster processing of both data streams, giving ROCI more time to make critical safety and navigational decisions.
 - Capable of providing range data to build terrain models with 1-2 cm accuracy.
 - LiDAR sensors, return accurate geometric information in three dimensions in the form of a 3D point cloud without requiring additional processing.
 - Do not rely on ambient lighting, we do not have to address the problems arising from adverse lighting conditions.
- Temperature Sensors (NTC Thermistor)
 - Will be used to measure the temperature of the onboard computer, batteries, and other electronic parts to provide critical temperature data required to keep the Li-Ion battery in the optimum condition during the charging cycle.
- Voltage Sensors
 - Monitors voltage data of various electronics. Low voltage may signal a potential issue, while other components may be in danger when voltage is excessive.

87 |

Control and Navigation

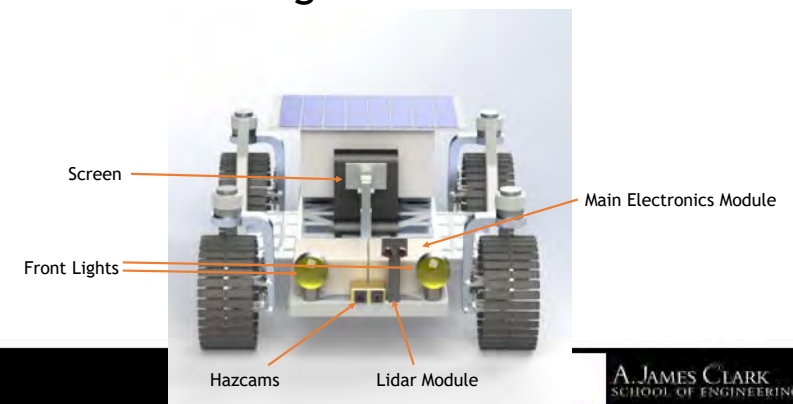

88 |

Control and Navigation

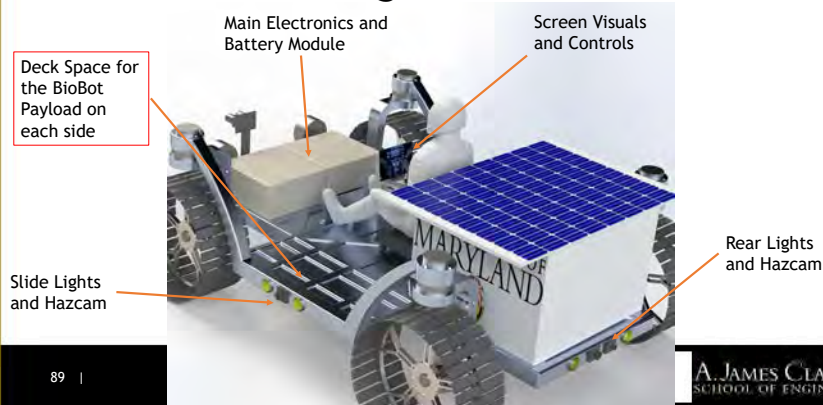

89 |

A. JAMES CLARK
SCHOOL OF ENGINEERING

Fault Protection

- The following Fault Protection Checks will be included in ROCI's Flight Software (Detailed Triggers and Responses are in the Backup Slides)
 - Slope Stability Fault
 - High Battery Depth of Discharge
 - CPU Fault or Reset
 - Camera Failure in Autonomous Mode
 - IRU Failure in Autonomous Mode
 - Camera Failure in Manned or Emergency Mode
 - IRU Failure in Manned or Emergency Mode
 - Excessive Speed in an Obstacle Filled Area
 - Excessive Acceleration
 - Turn Limit Fault
- Note: All Fault Triggers and EVA Crew Overrides will be logged for later fault diagnostic purposes along with recordings of all rover telemetry.

90 |

A. JAMES CLARK
SCHOOL OF ENGINEERING

Communications

- Ultra-High frequency antenna
 - With operating frequency of 400 Megahertz, it will use the orbiter to relay messages from Moon to Earth.
 - Transmission rates of up to 2 megabits per second on the rover-to-orbiter relay link.
- X-band High gain Antenna
 - Steerable long range antenna which will be used to transmit and receive data.
 - Will transmit data when the rover is stopped since constant orientation of high gain antenna might not be the most feasible.
- X-band Low gain Antenna
 - Will primarily be used to receive data at low rates

91 |

A. JAMES CLARK
SCHOOL OF ENGINEERING

Crew Systems

- To accommodate the crew:
 - Two seats are provided
 - The secondary seat is folded down to accommodate the payload module.
 - Both seats will use a 6 point harness to secure the EVA Crew
 - The harness will allow for easy removal if the EVA Crew needs to egress.
 - A 4 wheel configuration was selected to allow the EVA Driver to enter the rover from either side of the rover without having to climb over a wheel.
- Lights will be added to the vehicle to illuminate the area around the rover for the EVA Crew.
 - L1-17 Rover shall be capable of operating in any portion of the day/night cycle.
- Fault Protection code in the ROCI's computer will prevent the rover from exceeding stability limits.
- This will satisfy the following requirements:
 - L1-9: Rover design will accommodate roll-over protection and all required ingress/egress aids and crew restraints

92 |

A. JAMES CLARK
SCHOOL OF ENGINEERING

Crew Systems: Seat Harness

Six Point Harness [5]

Earth Testing Considerations

- Drive and Steering Motors will need to be resized
 - With the increase in weight due to Earth's Gravity
 - Drive Motors
 - Tractive Force will increase which will increase the required torque for the driver motors
 - Motor Speed will remain the same
 - Motor Gearing will need to be re-evaluated depending on increases in motor mass.
 - Steering Motors
 - Required steering torque will increase due to increased weight on wheels
 - Motor Speed requirements will remain the same
 - Chassis
 - Chassis analysis was performed in Earth Gravity and does not need to be resized.

Future Work

- Review weight on wheels determination method to improve weight distribution estimates and methods
- Perform a Thermal Analysis and Study to size survival and operational heaters
- Research Command and Data Handling components to size processors and recorders required for operations.
- Develop Flight Software Code for:
 - All Rover Modes
 - Navigation
 - Fault Protection
- Create link budgets for Communications and size Communications components
- Further Develop the Modular Wheel Concept

Conclusion

- In its current design iteration, ROCI will be able to handle the design mobility requirements.
 - The overall design will accommodate EVA Crew and Cargo
 - The rover will be able to handle a second EVA Crew in an emergency
 - The wheels will provide sufficient tractive force for terrain requirements.
 - Motors are sized for all needed torques and speeds.
 - The power system is sized to provide required sortie ranges and durations.
 - The rover has sufficient stability and crew systems for EVA Crew Safety



97 |

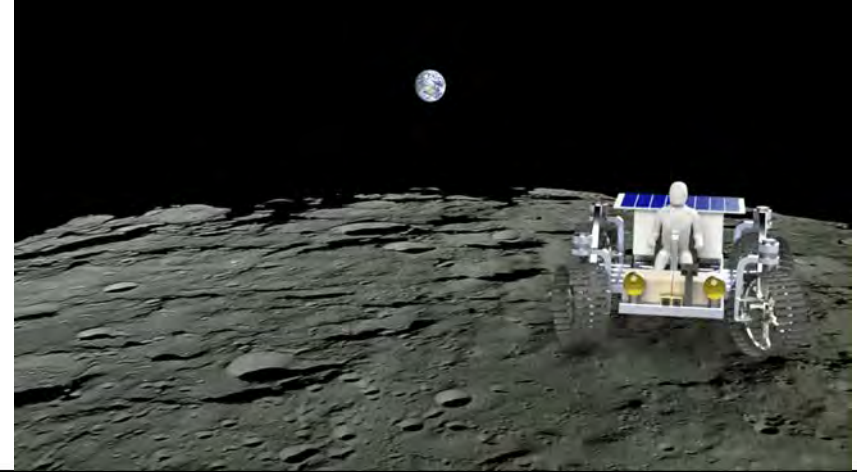

98 |

Reference

- [1] "Falcon 9 Payload User's Guide" Space Exploration Technologies Corp, April 2020.
- [2] "Saft solution for LEO and small GEO applications Based on Saft VL51ES Li-ion cell" SAFT, Space and Defense Division, 2020.
- [3] "RAD5545 SpaceVPX single-board computer" BAE Systems, 2020.
- [4] Rekleitis, I., and., "Autonomous Planetary Exploration using LIDAR data," 2009 IEEE International Conference on Robotics and Automation, IEEE, Kobe Japan., 2009
- [5] Stewart, R. "Think You Know Everything About Racing Harnesses?," Speed Hunters, 22 December 2017. <http://www.speedhunters.com/2017/12/think-you-know-everything-about-racing-harnesses/>
- [6] Eisenman, A., Liebe, C., Mainmone, M., Schwochert, M., Willson, R., "Mars exploration rover engineering camera" 2001 Proc. SPIE 4540, Sensors, Systems, and Next-Generation Satellites V, 2001
- [7] "Performance Friction Brake", 4Turbo, 10 December 2020. <https://www.4turbo.pl/performance-friction-brake-disc-front-right-slot,3,48431,47022>

99 |

Backup Slides

- Terramechanics and Wheel Study
- Stability
- Drive Gearing Trade Study
- Power
- Rover Modes
- Fault Protection

100 |

Terramechanics and Wheel Study

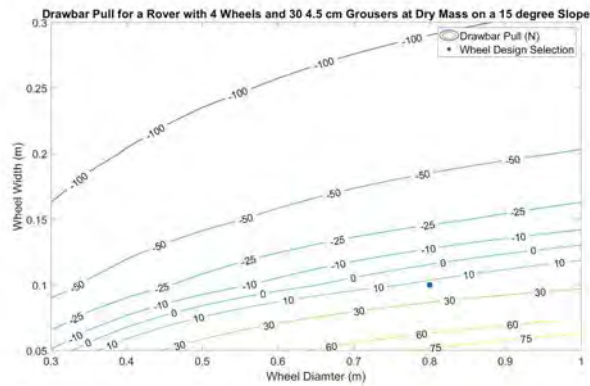

101 |

LARK
ENGINEERING

Terramechanics and Wheel Study

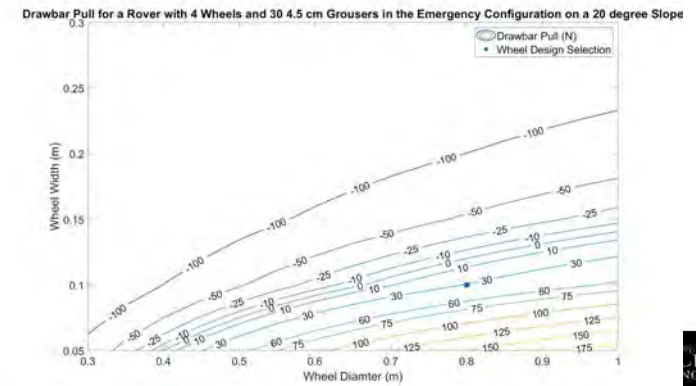

102 |

LARK
ENGINEERING

Terramechanics and Wheel Study

	Slope	Front Wheels			Back Wheels		
		Normal Force on per Wheel (N)	Wheel Thrust per Wheel (N)	Tractive Force per Wheel (N)	Normal Force on per Wheel (N)	Wheel Thrust per Wheel (N)	Tractive Force per Wheel (N)
Configuration	15	99.3	26.6	69.1	96.9	26.0	67.2
Dry Mass	-10	132.4	23.3	92.6	67.7	11.9	44.4
	20	117.3	42.7	85.4*	264.5	96.3	206.8*
Nominal	-20	203.4	74.0	155.6*	178.3	64.9	134.9*
	20	159.7	58.1	119.6*	290.8	105.8	229.1*
Emergency **	-20	254.7	92.7	198.6*	195.6	71.2	149.3*

* Note: Supports Requirement L1-4

** Note: Supports Requirement L1-8

103 |

A. JAMES CLARK
SCHOOL OF ENGINEERING

Terramechanics and Wheel Design

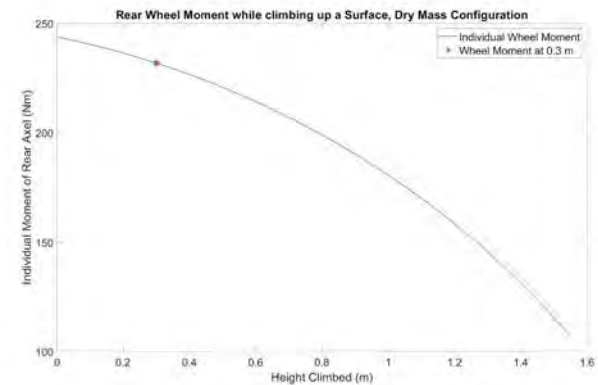

104 |

LARK
ENGINEERING

Terramechanics and Wheel Design: Climbing

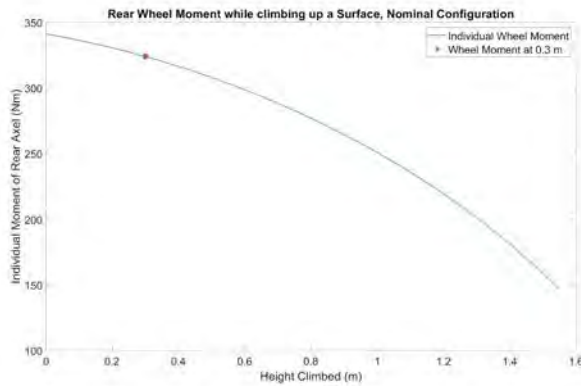

105 |

LARK
ENGINEERING

Terramechanics and Wheel Design: Climbing

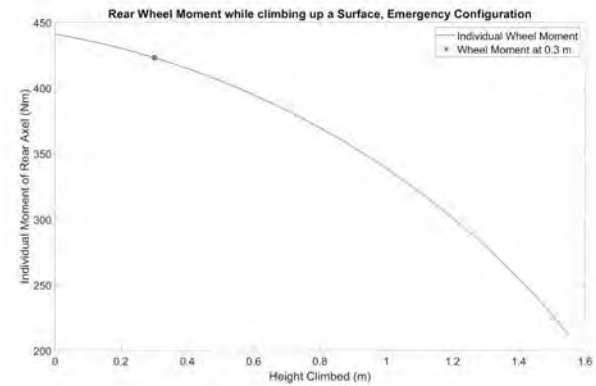

106 |

LARK
ENGINEERING

Terramechanics and Wheel Design: Climbing

Configuration	Individual Front Wheel Normal Force	Individual Back Wheel Normal Force	Individual Back Wheel Moment at 0.3 m	Individual Back Wheel Moment at 0 m
Dry	96.1	134.5	231.9	243.8
Nominal	192.1	269.0	324.0	341.3
Emergency	226.7	317.4	423.1	441.0

107 |

A. JAMES CLARK
SCHOOL OF ENGINEERING

Terramechanics and Wheel Design

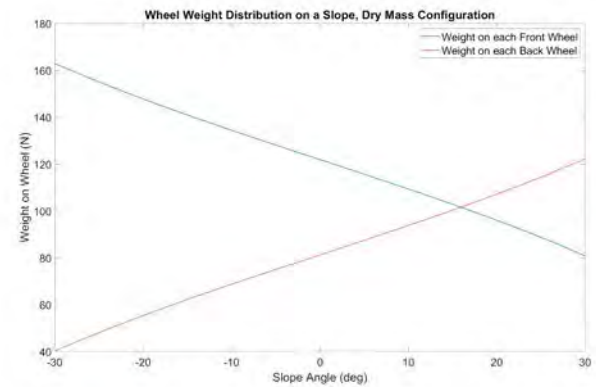

108 |

LARK
ENGINEERING

Stability: Turning

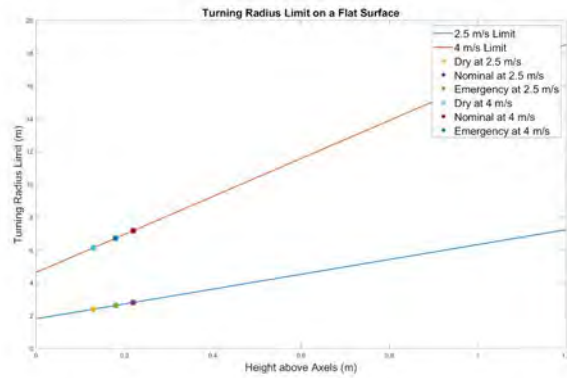

109 |

Stability: Turning

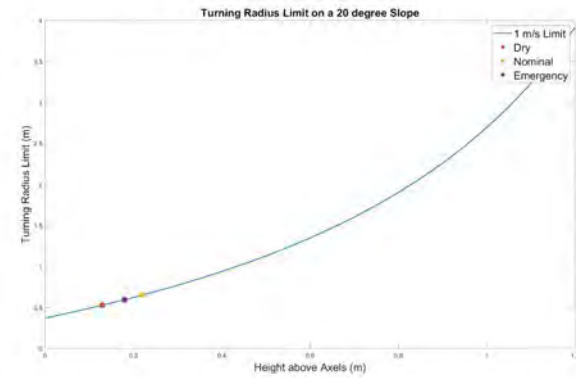

110 |

Stability: Acceleration

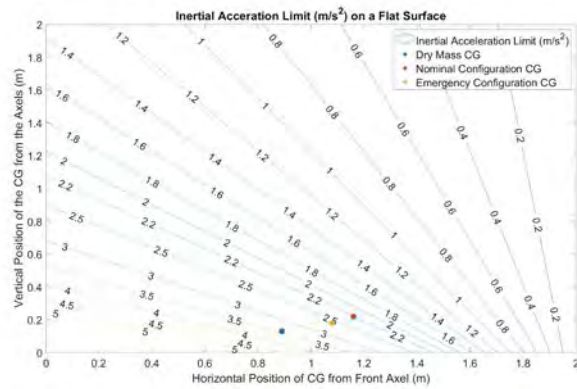

111 |

Stability: Deceleration

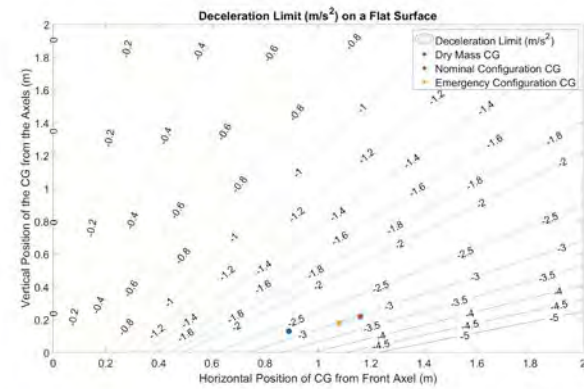

112 |

Drive Gearing Trade Study

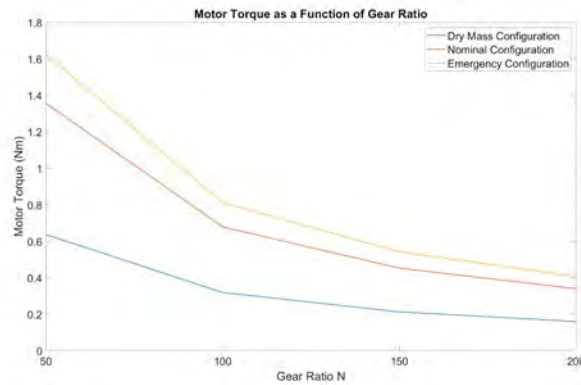

113 |

LARK
ENGINEERING

Drive Gearing Trade Study

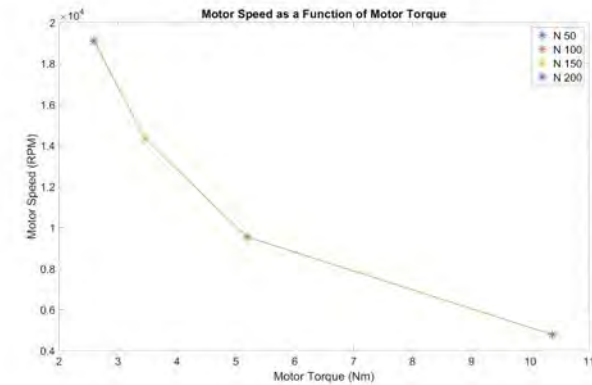

114 |

LARK
ENGINEERING

Power: Equations

- Power Profile (Wh) = (Dry Load * Dry Load Time) + (Nom Load * Nom Load * Time) + (Emergency Load * Emergency Load Time) + (HK Load * HK Load Time)
- Time to recharge (h) = (Power Profile / (Eff Battery to Loads * Eff Solar Array to Battery)) / (Solar Array Power - (HK Load / Eff Solar Array to Load))
- Solar Array Power = (Solar Array Area * Array W per m²) * Loss
- Loss = Sun Intensity * Panel Packing Factor * Measurement Uncertainty * Shadow Loss * (1 - Temperature Power Loss) * cos(Sun Incident Angle)
- Battery Capacity Used (Wh) = Power Profile / Eff Battery to Load

Note: Equations and Constants were acquired from ENAE 691 Power System Slides

115 |

A. JAMES CLARK
SCHOOL OF ENGINEERING

Power: Constants

- Efficiency of Battery to Load: 0.84
- Efficiency of SA to Battery: 0.86
- Efficiency of SA to Load: 0.9
- Sun Int: 0.9675 (Minimum Intensity at Solar Equinox)
- Panel Packing Factor: 0.85
- Measurement Uncertainty: 0.95
- Shadow Loss: 0.99
- Triple Junction GaAs Cells
 - Watts per m²: 399.1 w/m²
 - Temperature Power Loss: 0.295

116 |

A. JAMES CLARK
SCHOOL OF ENGINEERING

Rover Modes

- Deployment
 - Initial Mode for the Rover when the CLIPS Lander has successfully landed. The mode will handle autonomous deployment from the CLIPS Lander
 - When the CLIPS Lander has confirmed landing and deployed the disembarkment ramp, ROCI will:
 1. Power Up
 2. Perform a diagnostics check
 3. Establish Communications
 4. Confirm via Nav and Haz Cameras that the ramp is deployed
 5. Release restraints from the CLIPS Lander
 6. Exit the CLIPS Lander via the Disembarkment Ramp
 7. Park a short distance to allow the second ROCI rover to exit the CLIPS Lander
 8. Await instructions from Mission Operations

Rover Modes

- Autonomous Mode
 - The Rover will act autonomously based on instructions received from either Astronauts or Mission Operations.
 - This mode has two sub-modes:
 - Solo
 - In Solo mode:
 - ROCI will operate based on instructions from either Mission Operations or remote Astronauts
 - Navigation will be performed via Lidar, NavCams and HazCams
 - In Assist mode:
 - ROCI will operate under the command of the astronaut that is piloting it while the astronaut is disembarked from the Rover

Rover Modes

- Manned Mode
 - ROCI will operate under the control of the embarked Astronaut piloting it.
 - Lidar, NavCams, and HazCams will provide driver assists for the Astronaut
- Emergency Transport Mode
 - ROCI will operate under the control of the embarked Astronaut piloting it.
 - Solar Array Battery Charge Control is disabled due to solar array removal.
- Safe Mode
 - If Fault Protection detects a fault or directly commanded, ROCI will enter SAFE Mode.
 - All rover operations will cease and ROCI will remain stationary
 - Rover will prioritize recharging the battery.
 - Fault telemetry will be sent to both the Astronauts and Mission Operations.
- Park
 - The rover will slow down to a stop when entering this mode.
 - ROCI will maintain housekeeping loads only and direct remaining gathered electrical power from either the solar array or base umbilical power to charge control.

Fault Protection

- Slope Stability Fault:
 - Fault Trigger: Rover is on a slopes in excess of 40 degrees up slope or -55 degrees down slope
 - Response: Enter Park Mode
 - This will partially satisfy the following requirement:
 - L1-9: The Rover will incorporate roll-over protection for the crew and all required ingress/egress aids and crew restraints.
- High Battery Depth of Discharge
 - Fault Trigger: Depth of Discharge exceeds 90%
 - Response: Enter Park Mode to stop then enter Safe Mode
- CPU Fault or Reset
 - Fault Trigger: CPU Fault or Reset
 - Response: Enter Safe Mode

Fault Protection

- Camera Failure in Autonomous Mode:
 - Fault Trigger: Camera failure in Autonomous Mode
 - Response: Enter Park Mode to stop then enter Safe Mode
- IRU Failure in Autonomous Mode:
 - Fault Trigger: IRU Failure
 - Response: Enter Safe Mode
- Camera Failure in Manned or Emergency Mode:
 - Fault Trigger: Camera failure in Manned or Emergency Mode
 - Response: Notify the Astronaut of the Camera Failure and advice Him/Her/They to enter Park Mode and Investigate the Failure
- IRU Failure in Manned or Emergency Mode:
 - Fault Trigger: IRU Failure
 - Response: Notify the Astronaut of the Camera Failure and advice Him/Her/They to enter Park Mode and Investigate the Failure

Fault Protection

- Excessive Speed in an Obstacle Filled Area:
 - Fault Trigger: The Rover speed exceeds 1.5 m/s (Dry Configuration) or 1.7 m/s (Nominal or Emergency Configuration) with obstacles present
 - Response: The Rover will slow down to 1.4 m/s (Dry Configuration), or 1.6 m/s (Nominal or Emergency Configuration) until clear of obstacles. EVA Crew can override.
 - This will partially satisfy the following requirement:
 - L1-9: The Rover will incorporate roll-over protection for the crew and all required ingress/egress aids and crew restraints.
- Excessive Acceleration:
 - Trigger: Acceleration exceeds 1.3 m/s^2 (0.2 m/s^2 from the acceleration stability limit)
 - Response: Acceleration will be capped at 1.3 m/s^2 . The EVA Crew can override.
- Turning Limit Fault:
 - Trigger: The Rover is getting within 0.2 m of a turning limit.
 - Response: Prevent further reduction in turning radius.
- Note: All Fault Triggers and EVA Crew Overrides will be logged.



ENAE788X

Final Progress Report

SCAMP - Spacesuit Capability Augmentation Mission Platform

Charlie Hanner, Nicolas Bolatto, Zach Lachance



Space Systems Laboratory
Dept. of Aerospace Engineering

UNIVERSITY OF
MARYLAND

1

Overview



- Requirements and Objectives
- Concepts Explored
- Design Overview
- Terramechanics and Motor Design
- Steering
- Suspension System
- Stability and Braking
- Structural Design Details
- Sensors and Navigation
- Operations
- Power and Mass Budget
- Earth Analog Considerations

UNIVERSITY OF
MARYLAND

Space Systems Laboratory
Dept. of Aerospace Engineering

2

Mission Statement



- Perform a detailed design of a BioBot rover, emphasizing mobility systems
 - Chassis systems (e.g., wheels, steering, suspension...)
 - Support systems (e.g., energy storage)
 - Navigation and guidance system (e.g., sensors, algorithms)
- Design for Moon, then assess feasibility for Earth analog and Mars

UNIVERSITY OF
MARYLAND

Space Systems Laboratory
Dept. of Aerospace Engineering

3

Level 1 Requirements



ID	Requirement
M1	Rover shall have a maximum operating speed of at least 4 m/sec on level, flat terrain.
M2	Rover shall be designed to accommodate a 0.3 meter obstacle at minimal velocity.
M3	Rover shall be designed to accommodate a 0.1 m obstacle at a velocity of 2.5 m/sec.
M4	Rover shall be designed to safely accommodate a 20° slope in any direction at a speed of at least 1 m/sec and including the ability to start and stop.
M5	The rover shall have a nominal sortie range of 54 km at an average speed of 2.5 m/sec.
M6	Rover shall be capable of carrying one 170 kg EVA crew and 80 kg of assorted payload in nominal conditions.
M7	Payload may be modeled as a 0.25 m3 box.
M8	Rover shall be capable of also carrying a second 170 kg EVA crew in a contingency situation. Payload may be jettisoned if design permits.

UNIVERSITY OF
MARYLAND

Space Systems Laboratory
Dept. of Aerospace Engineering

4

Level 1 Requirements (Cont.)



ID	Requirement
M9	Rover design shall incorporate roll-over protection for the crew and all required ingress/egress aids and crew restraints.
M10	A nominal sortie shall be at least eight hours long.
M11	Two rovers must be launched on a single CLPS lander.
M12	A single rover shall mass ≤ 250 kg.
M13	Rovers shall be developed in time to be used on the first Artemis landing mission.
M14	Rover shall be capable of operating indefinitely without crew present.
M15	Rover shall be capable of being controlled directly, remotely, or automated.
M16	Rover shall be capable of following an astronaut, following an astronaut's path, or autonomous path planning between waypoints
M17	Rover shall be capable of operating during any portion of the lunar day/night cycle and at any latitude.

Baseball Card



SCAMP
SPACECRAFT CAPABILITY ACCELERATION DESIGN PLATFORM



Design capabilities:

- Climb 30° slopes loaded
- Overcome 0.2m obstacles at minimal velocity
- 4 m/s max. operating speed
- 54 km range at 2.5 m/s
- Capable carry of two EMU crew, 60kg assorted payload

2020 Fall Season Stats:

Peak Motor Power: 2.2 kW	Unloaded Mass: 226.0 kg	Crit Roll Angle: 45°
Battery Storage: 10.5 kWhr	Mass Margin: 10.3%	Crit Pitch Angle: 53°
Recharge: 90%	Loaded Mass: 646.0 kg	DP margin (20°): 91.2 H
Battery Margin: 30%		DP margin (28°): 282.7 H

S.C.A.M.P. is a modern rover designed to provide astronauts with ease of transport through independent wheel position adjustment. Rotating linear actuators dedicated to each wheel allows for both active roll and pitch control of the rover, providing large advantages in slope activities such as climbing, turning, and accelerating.



Render



Design Overview

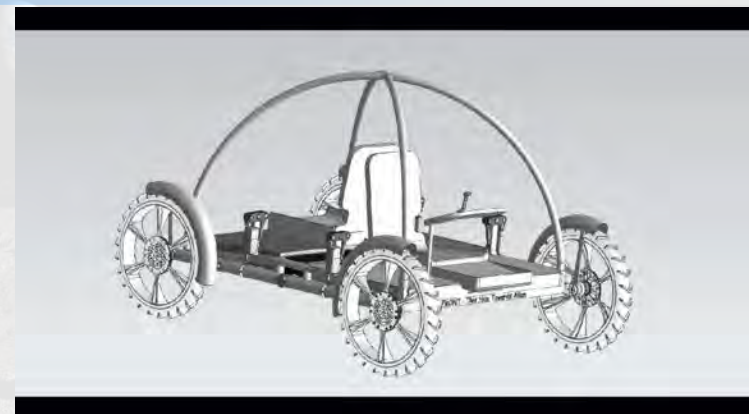

Design Overview – All 0°



UNIVERSITY OF
MARYLAND

9

Space Systems Laboratory
Dept. of Aerospace Engineering

Design Overview – All 45°



UNIVERSITY OF
MARYLAND

10

Space Systems Laboratory
Dept. of Aerospace Engineering

Design Overview – Obstacle Compensation



UNIVERSITY OF
MARYLAND

11

Space Systems Laboratory
Dept. of Aerospace Engineering

Design Overview – Pitch Control



UNIVERSITY OF
MARYLAND

12

Space Systems Laboratory
Dept. of Aerospace Engineering

Design Overview – Roll Control



UNIVERSITY OF
MARYLAND

13

Space Systems Laboratory
Dept. of Aerospace Engineering

Launch Configuration CAD

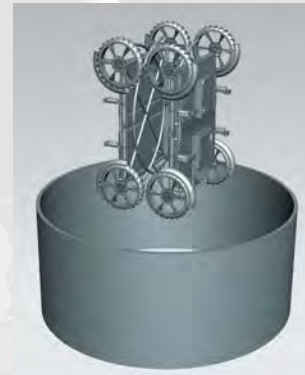

(Picture linked)

Credit: Astrobotic – Official Griffin Lander

UNIVERSITY OF
MARYLAND

14

Space Systems Laboratory
Dept. of Aerospace Engineering

Terramechanics



- Trades
 - Drawbar Pull (DBP) vs Wheel Diameter vs Wheel Width
 - Grousers vs No-Grousers
 - Power vs Wheel Diameter vs Wheel Width
 - Torque vs Wheel Diameter vs Wheel Width
 - Number of Wheels vs Wheel Diameter vs Wheel Width
- Wheels
 - Diameter varying from 0.6 to 1 m
 - Width varying from 0.1 to 0.5 m
 - 4- and 6-wheel configuration
- Case Study Parameters
 - Flat terrain at 4 m/s velocity
 - 20° slope at 1 m/s velocity (required)
 - 30° slope at 1 m/s velocity (desired)
 - Rover mass of 670 kg

UNIVERSITY OF
MARYLAND

15

Space Systems Laboratory
Dept. of Aerospace Engineering

Wheel Sizing Rationale



- Minimum wheel size examined 0.6m due to 0.3m maximum obstruction height for crawl
 - Places us within ~20-40" off-road wheels for ATV's or Jeeps for Earth analogue
- Assuming grouser height of ~5cm, positive DP is viable with diameters greater than 0.65 m at ~2-5" widths (0.05 and 0.1 m lines in plots below)
 - Number of grousers determined by the min/max grouser number formulas for each diameter
 - Motor requirements generated from these

UNIVERSITY OF
MARYLAND

16

Space Systems Laboratory
Dept. of Aerospace Engineering

4 Wheels, Slip = 0.5 Terramechanics Analysis (20 deg)

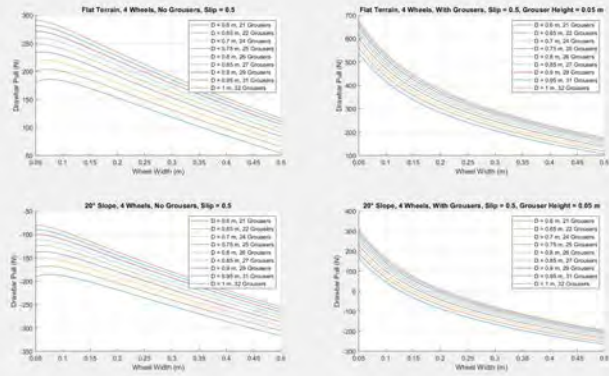

4 Wheels, Slip = 0.5 Terramechanics Analysis (30 deg)

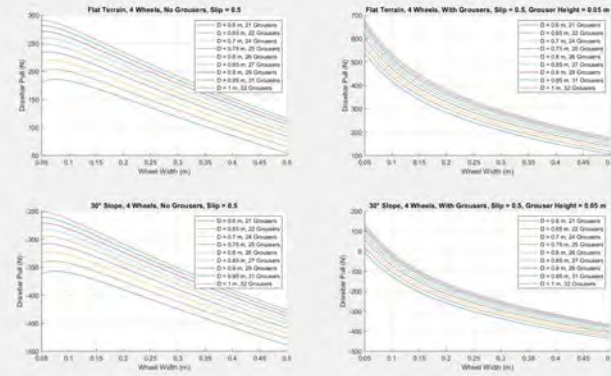

6 Wheels, Slip = 0.5 Terramechanics Analysis

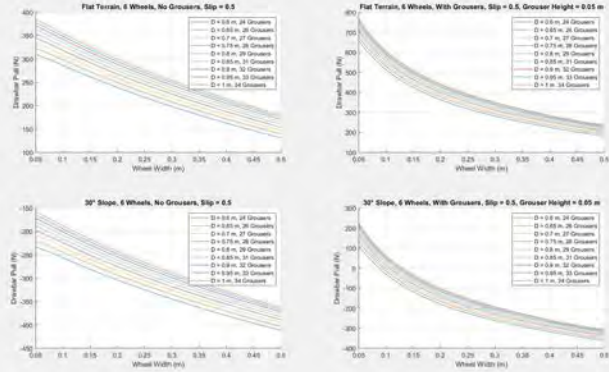

6 Wheels, 4 Driven, Slip = 0.5 Terramechanics Analysis

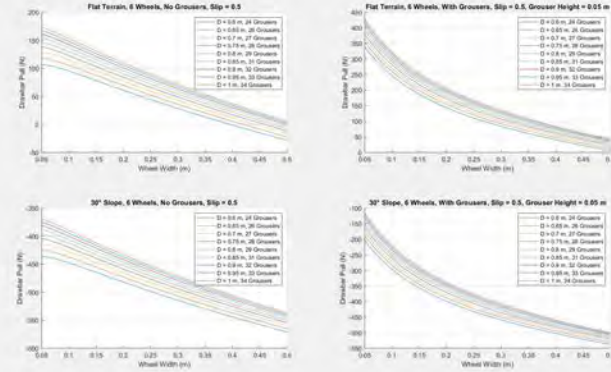

Drawbar Pull vs Slip



Grousers comparison, 30° incline, 0.05 m to 0.1 m width

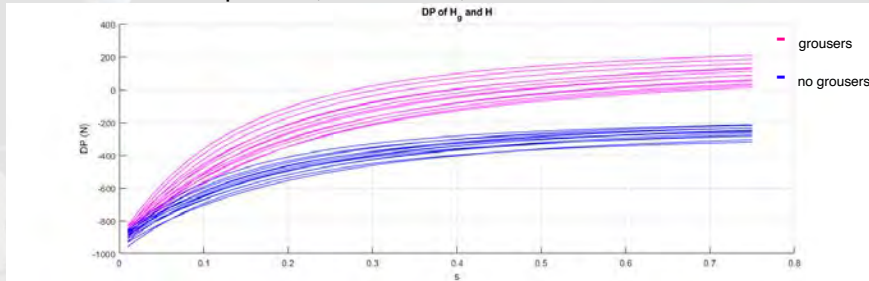

Grouser Height Trade Study



- Wheel sizing was selected from wheel sizing trade studies
- Wheel Diameter = 0.8 m
- Wheel Width = 0.055 m
- 4 Wheel Configuration
- 30 degree slope

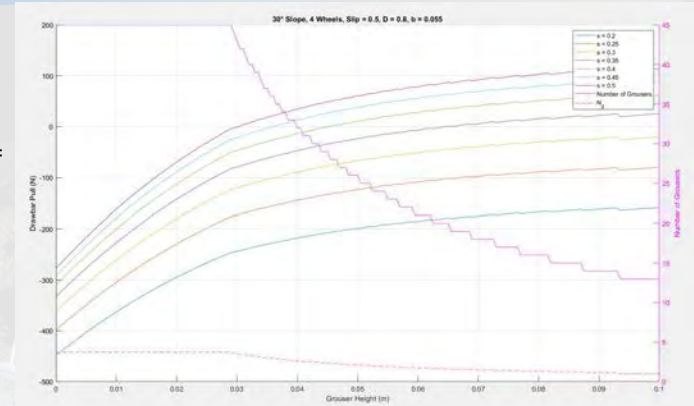

Terramechanics Conclusions



- Grousers are required to navigate slopes in all configurations
- Non-driven wheels are highly detrimental to drawbar pull and system mass
- 4-wheel configuration chosen to reduce system mass since positive drawbar pull is achievable
- 0.8 m wheel chosen to avoid wall-climbing scenario when managing 0.3 m obstacles
- 0.8 m diameter wheel has positive drawbar pull for 0.05 to 0.075 m width wheels with grousers on a 30 degree slope and up to 0.175 m width for a 20 degree slope

Terramechanics Conclusions (Cont.)



- 232.7 N drawbar pull margin on a 20 degree slope
- 61.2 N drawbar pull margin on a 30 degree slope
- 26 grousers, 5 cm long chosen as a compromise between additional drawbar pull and having long and impractical grousers

Torque and Power Trade Studies



- Average required torque and power per wheel for various diameters and widths
- Minimum required plots defined as values required to achieve 0 drawbar pull (just enough to overcome resistive forces)
 - Grousers vs no grousers comparison does not impact this analysis
 - Flat terrain vs slope comparison conducted
- Maximum required plots defined as values required to achieve maximum possible tractive force (lunar drag racing)
 - Grousers vs no grousers comparison conducted
 - Flat terrain vs slope comparison does not impact this analysis
- Linear speeds used for power graphs are 4 m/s on flat terrain and 1 m/s on slope

Average Required Torque Per Wheel

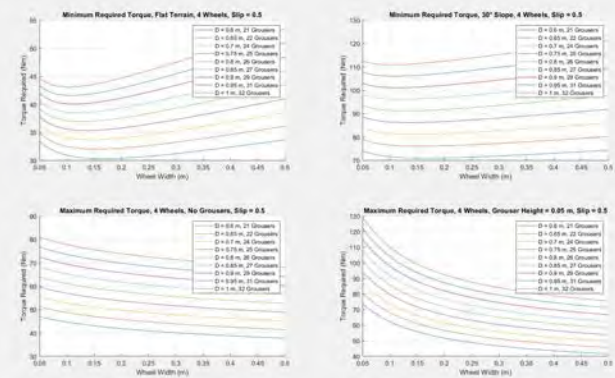

Average Required Power Per Wheel

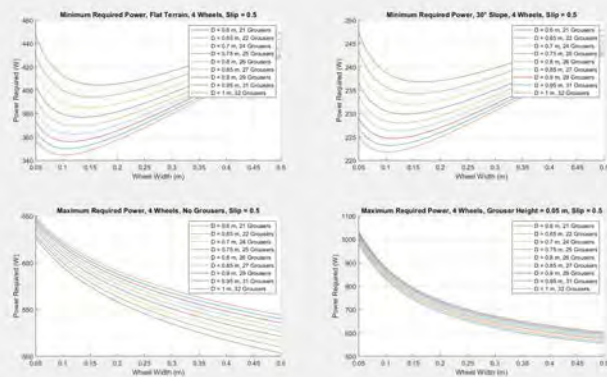

Torque and Power Trade Studies Conclusions



- Optimal wheel size for torque and power are dissimilar and vary based on the slope
- Required torque and power significantly reduced by grousers
- Torque and power requirements could be decreased slightly for higher wheel widths, but would reduce the drawbar pull margin (especially on slopes)
 - For most situations analyzed, benefit would be less than 5 N-m in torque and 20-30 W in power before negative drawbar pull achieved
 - Chose to keep wheel design parameters from the terramechanics analysis for the drawbar pull margin benefits in exchange for the slight increase in torque and power

Motor Requirements vs. Wheel Diameter (Lunar)

4 wheel config., 30 degree slope, 1 m/s, wheel width = 0.055 m

Diameter (m)	Required RPM at hub	Required Torque at hub (Nm)
0.6	127	74
0.7	109	83
0.8	95	93
0.9	85	103
1	76	112

Motor Trade Study

Type	Advantages	Disadvantages
Brushless DC	<ul style="list-style-type: none"> - Long lifespan - Low maintenance - High efficiency - Mechanically simple 	<ul style="list-style-type: none"> - Higher cost - Requires motor controller
Brushed DC	<ul style="list-style-type: none"> - Low cost - Easy to control 	<ul style="list-style-type: none"> - High maintenance - Reduced lifespan - Lower efficiency - Sparking
AC Induction	<ul style="list-style-type: none"> - High reliability - Low cost - Commonly sold with paired differentials 	<ul style="list-style-type: none"> - Requires AC power supply - High voltage (480V+ generally) - Lower efficiency
AC Synchronous	<ul style="list-style-type: none"> - Constant speed under load 	<ul style="list-style-type: none"> - Requires AC power supply - Speed dependent on AC frequency
Stepper	<ul style="list-style-type: none"> - High holding torque - Precise 	<ul style="list-style-type: none"> - High cost - Requires motor controller

Motor Trade Study Conclusions

- Lots of AC motors fit our requirements, but AC would require significant (high-voltage) power considerations and an inverter
- Brushless DC motor selected for long lifespan and low maintenance
- Integrated motor-planetary gearbox motors were higher mass and volume than using harmonic drive
- Harmonic drive input rpm limits would not allow for wheel diameters smaller than 0.7m at rated torque for Earth-analogue
- Harmonic drive selected as motor gearbox for its lower mass and size, despite not being transferrable to Earth-analogue

Motor Selection

From requirements of a 0.8m wheel:

- 93 Nm achieved after 50:1 GR harmonic requires motor to have 1.9 Nm stall torque
- 95 rpm after 50:1 GR requires motor no-load speed to be over 4750 rpm

Kollmorgen RBE-02112

- Continuous stall torque = 2.4 Nm
- No-load speed = 5100 rpm
- Small form-factor, frameless for wheel-hub integration
- Lightweight @1.83 kg combined with harmonic

With 50:1 harmonic drive:

- CSG-25-50

Continuous Duty Capability for 130°C Rise — RBE - 02110 Series

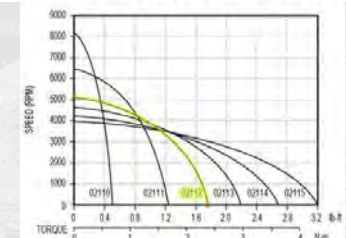

Steering Trade Study



- Steering considerations for this system were mainly driven by three main requirements
 - Astronaut unlikely to walk in nice arcing paths
 - Areas of interest are in rough terrain
 - Need to always stay within range (10 m) of astronaut
- Five steering conventions (Ackermann, skid, trailer, differential, and independent) were considered



Steering Trade Study (Cont.)



Type	Description	Advantages	Disadvantages
Skid-Steer	- Uses different wheel rotation rates to induce turning	- Low mass - Low complexity	- High power consumption - Can only drive straight or rotate in place/arcs
Differential Drive (Swiveling Wheels)	- Same as skid-steer but front or back wheels are free-spinning	- Low mass - Low complexity - Lower power consumption compared to skid-steer	- Cannot drive all wheels effectively so cannot get required drawbar pull
Trailer	- One set of wheels rotates around the central point of the axle	- Reduced power consumption - Low mass - Low complexity	- Power inefficiencies in rear wheels - Requires large unobstructed range of motion for wheel axle
Ackermann	- One or both set of wheels turn in place and at different angles	- Lower steering power requirements compared to trailer steering - Crawling capability with both sets of wheels steered	- Higher complexity - Increased mass
Independent	- Each wheel controlled separately	- Full range of motion - Low steering power requirements	- Significant mass - Very high complexity

Steering System: Concepts Explored



Ackermann-inspired independent steering system

- Independent rack-and-pinion/linear actuator steering of front and rear wheels
- Higher mobility through independent vectoring of wheels at slight cost of more required actuators (enables diagonal crawl shown below)

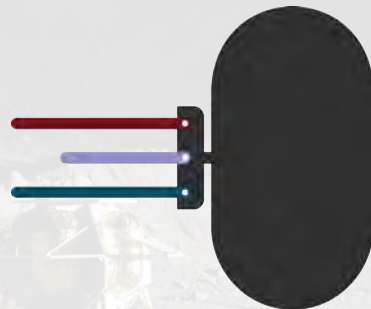

Steering System : Concepts Explored (Cont.)

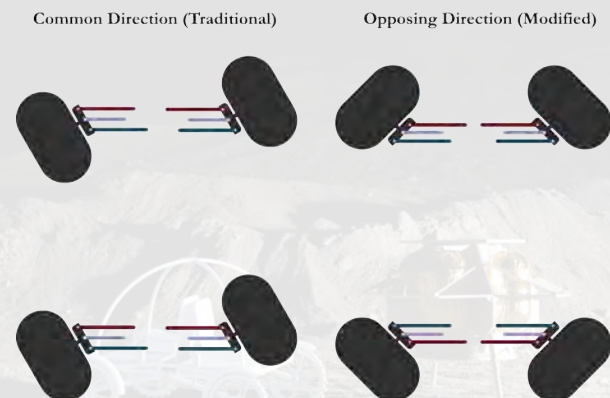

Steering System Design



- Ackermann-based steering was deemed infeasible due to steering rack/motor limiting designs in mass and volumetric considerations (i.e. obstacle clearing)
- Conflicts with the desired active suspension (described in the next section), which was deemed to be more beneficial
- Independent steering too massive
- Skid steering selected to minimize weight and to avoid conflict with the active suspension design

Steering Power Requirements



- Requirement: minimum 20 deg/s turn rate selected to ensure good astronaut following
- Power Required: 109 W
- Turning Radius: 1.25 m
- Extra drawbar pull and motor power margin saved for skid-steer

Suspension



- Requirements
 - Must be able mount linear actuators and pass loads into spring-damper system
 - Must mount rigidly to rover frame, and not interfere with astronaut's nominal operations
- Goals:
 - Independent control of pitch and roll of rover chassis for aid in hill climbing
 - Individual wheel positioning control

Suspension: Concepts Explored (Mobility Focus)



Articulated bogey

- Passive pitch
- Active roll control
 - Variable body clearance
 - Lower COM when navigating smooth terrain, large slopes
 - Increase body clearance when navigating rough terrain with obstacles
 - Raise one set of wheels while lowering the other, allowing rover to stay vertical while navigating parallel to slopes
 - Inspired by SCARAB
 - According to their paper, maintaining a vertical orientation lowers downhill slip when compared to keeping rover perpendicular to ground
 - Further analysis will show valid range of possibilities as motor, suspension, and steering designs become more formal

Wettergreen et al. "Design and Experimentation of a Rover Concept for Lunar Crater Resource Survey", CMU, 2009.

Suspension: Concepts Explored



- Need some form of passive vibration damping for astronauts or robotic payloads
- Aligning suspension system mount with the axis of wheel rotation will allow for simplified turning
- Tune-able (manual/electronic) shock absorbers can be easily accessed
- Adjusting relative location of upper point allows for raising and lowering of chassis
- Possible integration with active suspension



Suspension Trade Study



Type	Description	Advantages	Disadvantages	Sub-Types
Rigid	- No suspension	- Very low mass - Very low complexity	- Extremely rough on astronauts - Poor weight transfer	
Independent	- All wheels can move independently	- High weight transfer - Effective at reducing body motion	- Higher mass - Medium complexity	- Macpherson Strut - Double Wishbone
Rocker/Bogie/ Rocker-Bogie	- Wheels on each side constrained by rotating connection beams such that they can move independently while still distributing weight	- Effective at reducing body motion - High weight transfer - Less likely to tip (compared to springs) - Can clear obstacles up to 2x wheel diameter	- Not as effective at high speeds (shock from obstacles)	
Articulated/ Segmented	- Half of the rover moves with the corresponding wheels	- Good weight transfer for mass	- Large body motion - Not good for sitting on - Rough on astronauts	
Dependent	- Movement on one side affects movement on the other	- Less complex - Low mass	- Rough on astronauts	- Leaf Spring - Watt's Linkage - Live Axle
Active	- Wheel height and weight distribution is controlled electronically	- Wide range of control - Capable of high performance	- Computationally intensive - Time delay before reaction - Very high mass and complexity	- Electromagnetic - Hydraulic

Suspension Trade Study Conclusions



- Rigid, articulated, segmented, and dependent steering are too rough for astronauts to ride (as seen in results from RAVEN)
- Rocker/bogie/rocker-bogie system does not function well at the speeds required as it was designed for slow-speed operation
- Segmented suspension would require additional wheels (and therefore high mass)
- Articulated suspension would be very difficult for a rideable rover (unbalanced and poor astronaut placement)
- Active suspension would likely be too rough by itself due to time delays, but is useful in the ability to control wheel position

Suspension Design



Active suspension will be used with passive independent suspension to enable control over wheel position

- Allows for keeping rover flat while navigating slopes/obstacles
 - Better stability performance
 - Ability to control CG (required for better performance with moving robotic umbilical arm swinging CG around)
 - Can significantly reduce stability dependence on CG height – decoupled in ideal case (useful for large robotic umbilical arm shifting CG up)
- Drastically reduces high-centering (can lift rover up from obstacles if it gets stuck)

Passive Suspension Dynamics

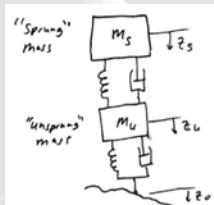

Parameter	Value
Spring Constant - k	2400 N/m
Damping Coefficient - c	1200 Ns/m
Damping Ratio	0.9969
Oscillation Frequency	0.05 Hz
Deflection distance (linear)	0.1 m

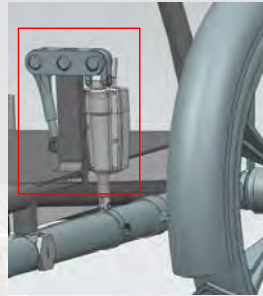

<https://spacecraft.ssl.umd.edu/academics/788XF20/788XF20L16.climbingx.pdf>

- Torsional springs would be used for compactness
- Analysis done with linear equivalent spring

Stability: Initial Rover Footprint Sizing

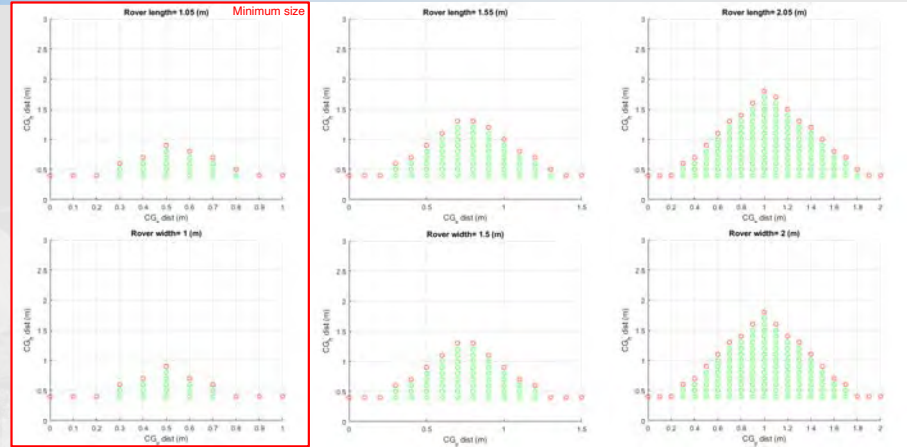

Stability: Initial Rover Footprint Sizing

- 2-meter rover length chosen as having acceptable stopping times
- 0.4m stopping distance at 1m/s
- 6m stopping distance at max speed
 - Long distance, but rover will only be at max speed on smooth, even terrain
 - Tested in simulation to be a decent stopping distance for open terrain

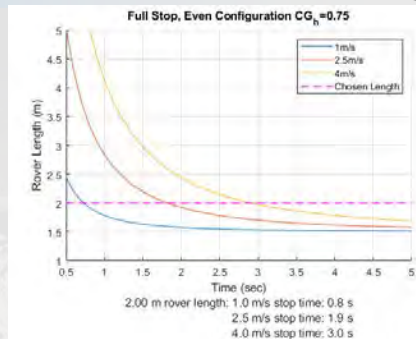

Stopping Acceleration: $\sim 2\text{m/s}^2$

Stability: Initial Rover Footprint Sizing

- Conducted turning stability analysis over several rover widths
- Not much information was gleaned from doing this turning circle analysis, at least as far as iterating design
- Chose 1.5m rover width, mostly using the roll stability on slope analysis
- Lesson learned: speed while turning or turn radius must be limited to avoid flipping (in all cases)

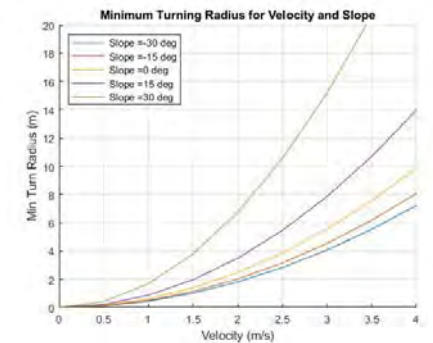

For CG height = 0.75m,
Rover width = 1.5m

Active Suspension: Fore/Aft Slope

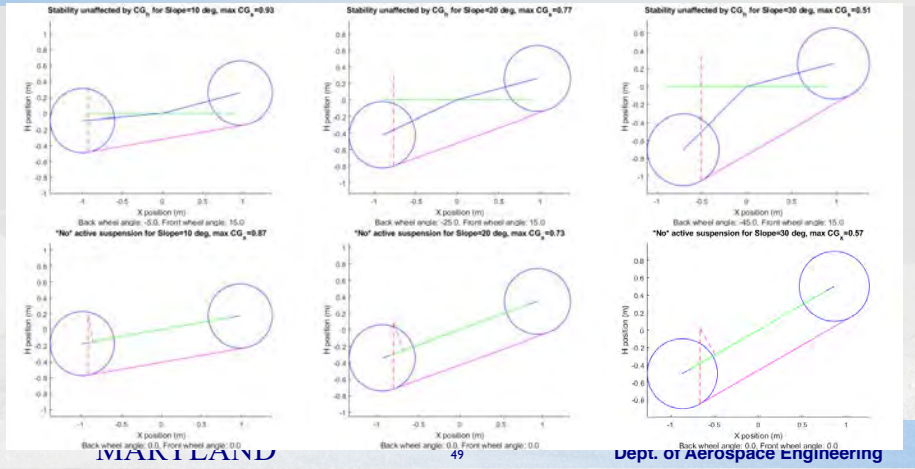

Active Suspension: Cross Slope

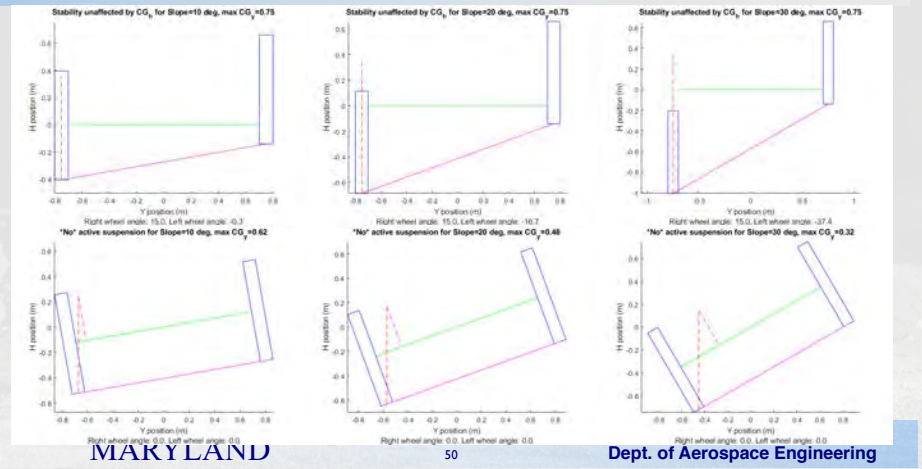

High-Centering on Flat Terrain

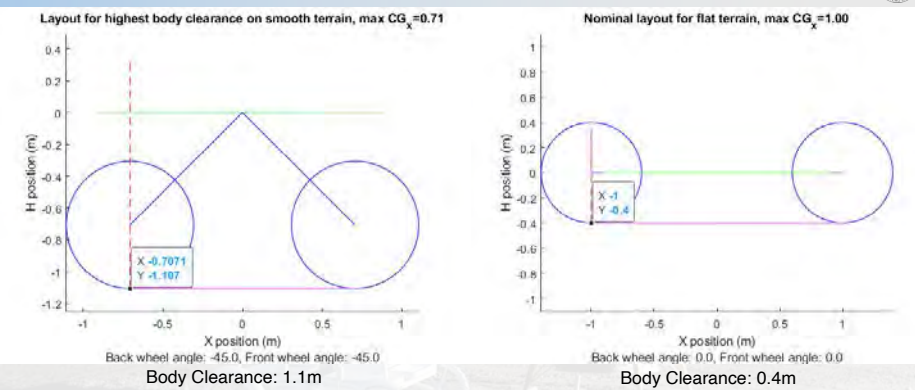

High-Centering on 30 deg Slope

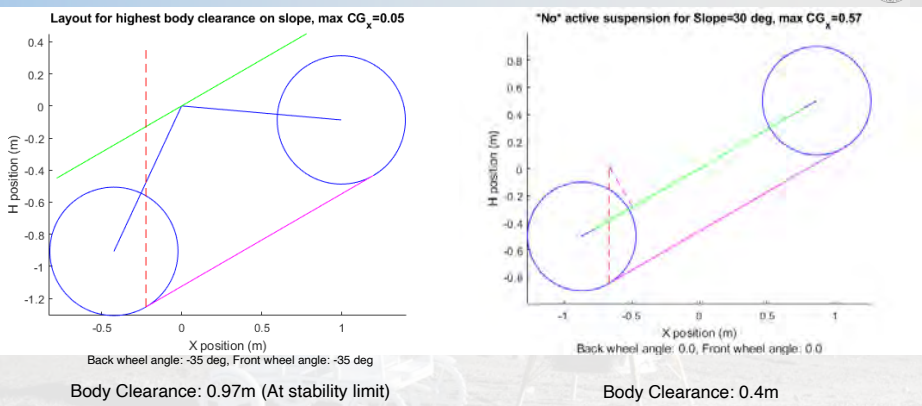

Acceleration/Deceleration Along Slopes

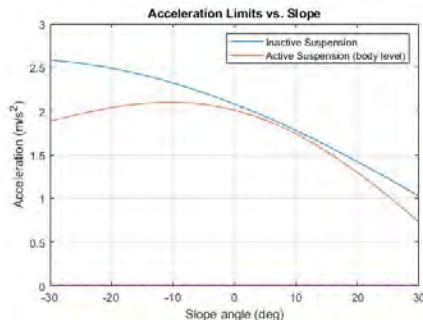

Inactive suspension acceleration slope limit: 54 deg
Active suspension acceleration slope limit: 42 deg

Max acceleration up 30° slope: 0.73 m/s²
Max acceleration down 30° slope: 1.88 m/s²

UNIVERSITY OF
MARYLAND

53

Space Systems Laboratory
Dept. of Aerospace Engineering

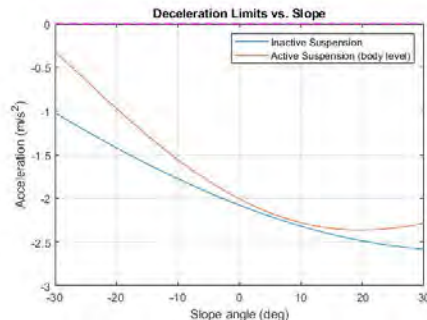

Inactive suspension deceleration slope limit: -53 deg
Active suspension deceleration slope limit: -35 deg

Max deceleration up 30° slope: 2.29 m/s²
Max deceleration down 30° slope: 0.32 m/s²

Active Suspension: Stopping Time Benefits

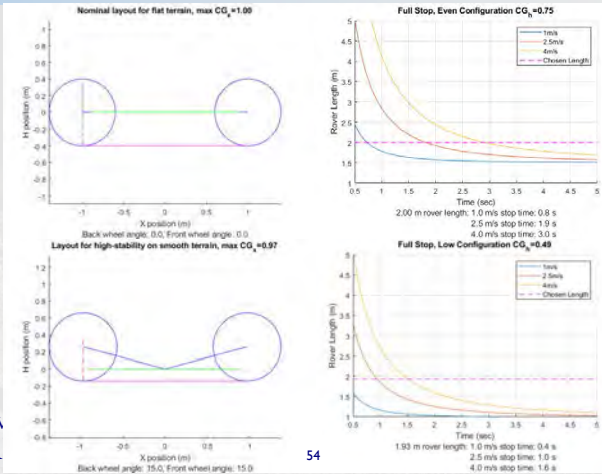

2x faster!

Space Systems Laboratory
Dept. of Aerospace Engineering

Stability Conclusions



- Active suspension has many benefits over inactive suspension
 - Huge roll stability increase
 - Avoids high-centering problems, since body clearance can be adjusted
 - Variable configuration can adapt to situation to provide higher stability
 - Lower CG when body clearance is not necessary
 - Keep body level on slopes to ignore CG height
- Acceleration on slopes is generally lower on slopes in displayed configurations, but a layout that favors acceleration can be used
- Capabilities can be expanded much further if more intelligent software and control loops are implemented
 - "Lean" into turns for tighter turning circles at higher speeds
 - Actively manage wheel weight distribution by adjusting wheel placement when navigating obstacles

UNIVERSITY OF
MARYLAND

55

Space Systems Laboratory
Dept. of Aerospace Engineering

Stability Summary



- Mass
 - Unloaded: 226.6 kg (10% margin)
 - Loaded: 646.6 kg
- CG
 - (0, 0, 0) defined as front right corner of chassis on the ground
 - Unloaded (x, y, z): (1.09, 0.79, 0.55) m
 - Loaded (x, y, z): (1.04, 0.78, 0.77) m
 - Critical Roll: 45 degrees
 - Critical Pitch: 53 degrees

UNIVERSITY OF
MARYLAND

56

Space Systems Laboratory
Dept. of Aerospace Engineering

Stability Summary (Cont.)



Chassis Parallel to Ground

- Maximum Deceleration
 - Flat terrain (4 m/s): -2.08 m/s^2
 - Down 30 degree slope: -1.02 m/s^2
- Stopping Distance
 - Flat terrain (4 m/s): 3.85 m
 - Down 30 degree slope (1 m/s): 0.49 m
- Stopping Time
 - Flat terrain (4 m/s): 1.92 s
 - Down 30 degree slope (1 m/s): 0.98 s

Chassis Kept Level

- Maximum Deceleration
 - Flat terrain (4 m/s): -2 m/s^2
 - Down 30 degree slope (1 m/s): -0.32 m/s^2
- Stopping Distance
 - Flat terrain (4 m/s): 4.0 m
 - Down 30 degree slope (1 m/s): 1.56 m
- Stopping Time
 - Flat terrain (4 m/s): 2.0 s
 - Down 30 degree slope (1 m/s): 3.13 s

Unloaded Rover



Fully Loaded Rover



Weight Transfer Over Obstacles



- Assumptions
 - Spring length (linear equivalent, unstretched) = 0.5 m
 - Spring constant (linear equivalent) = 2400 N/m
 - CG located 0.6 m above geometric center
- Example cases are shown covering range of potential extremes

Weight Transfer Over Obstacles



Obstacle (cm)	Force on Wheel 1 (RF) (N)	Force on Wheel 2 (RB) (N)	Force on Wheel 3 (LF) (N)	Force on Wheel 4 (LB) (N)
Nominal (0)	203	203	203	203
RF: 30	355	14	31	410
RF: 10	253	140	145	272
RF: -30	48	389	373	0
RF: -10	152	265	260	133
RF: 30, RB: 30	166	166	239	239
RF: 30, RB: -10	381	0	0	429
RF: 30, LF: 30	183	222	183	222
RF: 30, LF: -10	375	0	0	435
RF: 30, LB: 10	387	0	0	423
RF: 30, LB: -10	285	71	94	360

Weight Transfer Over Obstacles (Contingency)



Obstacle (cm)	Force on Wheel 1 (RF) (N)	Force on Wheel 2 (RB) (N)	Force on Wheel 3 (LF) (N)	Force on Wheel 4 (LB) (N)
Nominal (0)	271	271	271	271
RF: 30	413	80	103	490
RF: 10	319	207	215	344
RF: -30	130	463	440	53
RF: -10	224	335	327	199
RF: 30, RB: 30	220	220	322	322
RF: 30, RB: -10	477	32	30	546
RF: 30, LF: 30	245	298	245	298
RF: 30, LF: -10	469	7	56	554
RF: 30, LB: 10	486	24	39	537
RF: 30, LB: -10	340	136	167	443

Wheel Arm Calculations



- Most likely failure mode: bending with wheel arms at minimum chassis height
- Cylinder of 2219 Aluminum selected
 - Cylinder for strength to weight
 - 2219 Aluminum used for LRV
- Size selected: radius of 1.5" (38.1 mm), wall thickness of 1/8" (3.175 mm) - easy to procure
- Factor of safety (yield): 4.5
- Deflection: 1.6 mm
- Chose to have stronger than required to have low deflection and in anticipation of other loading scenarios (impacts, launch, etc.), which were not analyzed



Chassis Analysis



- Chassis design was inspired by combining both spaceframe and backbone styles
 - Spaceframe considerations allowed for mass-efficient inclusion of larger volumetric areas for payload
 - Backbone inspiration provided battery protection, and mid-section rigidity
- Chassis requirements for this project included:
 - Contain dedicated volume for payload
 - Roll cage inclusion
 - Support considerations for suspension and wheel support mounting

Chassis CAD

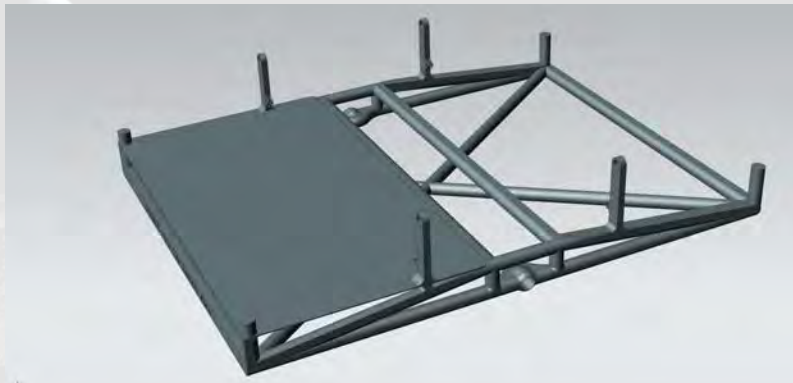

UNIVERSITY OF
MARYLAND

65

Space Systems Laboratory
Dept. of Aerospace Engineering

Design Details - CAD

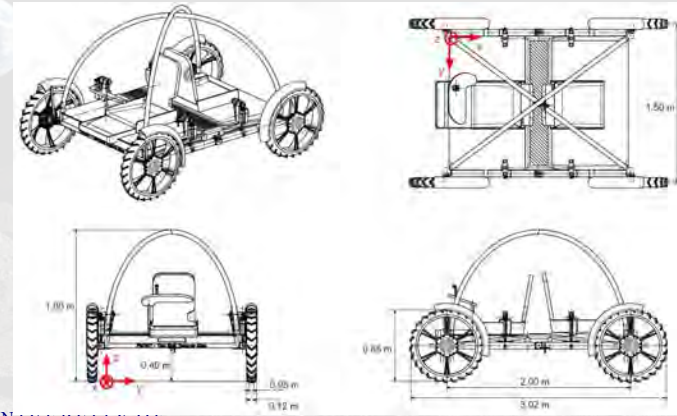

UNIVERSITY OF
MARYLAND

66

Space Systems Laboratory
Dept. of Aerospace Engineering

Wheel-Motor Details - CAD



UNIVERSITY OF
MARYLAND

67

Space Systems Laboratory
Dept. of Aerospace Engineering

Wheel-Motor Details - CAD

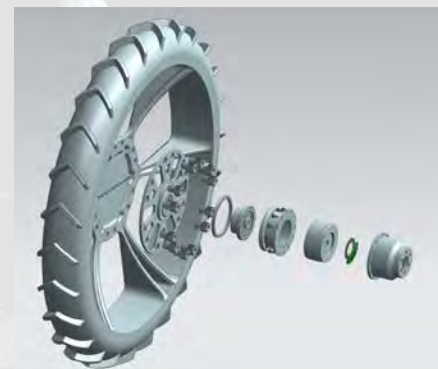

Components left to right:

1. Moon wheel
2. Interface plate
3. Hub attachment 5/16-18 bolts
4. Harmonic balancing bearing
5. CSG-25-50-2A-GR Harmonic Drive
6. Actuator Housing 1
7. Actuator Housing 10-24 bolts
8. Kollmorgen RBE 02112
9. Example encoder
10. Actuator Housing 2

UNIVERSITY OF
MARYLAND

68

Space Systems Laboratory
Dept. of Aerospace Engineering

Wheel Suspension - CAD



1. Damper
2. Suspension lever
3. Torsional spring in middle pivot (not in view)
4. Linear actuator

Sensors



- Terrain Mapping Sensors
 - Stereo cameras
 - Flash LIDAR (scanning LIDAR if unable to procure)
 - Hazcams
- Astronaut Tracking
 - Stereo cameras
 - Visual tag (i.e. AprilTags)
 - Motion tracking (while rover is stationary)
 - Radio tags and tracking, dual antenna, or phased array antenna
 - Log of astronaut position
 - Umbilical encoders (NIAC only)
- Positional Sensors
 - Continuous motor encoders
 - IMUs
 - GPS (Earth analogue only)

Sensors - Position Determination



- Dead reckoning utilizing position logging and motor encoders
- Used as a rough estimate of position
- Position further refined by IMU and position relative to obstacles with terrain mapping

Mapping



- Rover will have a (limited) terrain mapping capability
- Utilize distinct obstacles to keep track of relative position and to better navigate (especially in tracking mode)
- Map only stored while rover is still in the same area to reduce computational requirements (as astronaut tracking will require a significant portion of computational resources)
- Only required features stored (large obstacles, short-term astronaut path, etc)

Navigation

- IMUs, encoders, etc. to generate rover position in reference frame (base station as reference location)
- Astronaut tracking sensors to log astronaut position
- Terrain mapping (limited)
- Modified Lifelong Planning A* search algorithm
 - Advantage over A* when visualization is not complete (i.e. impassible terrain obscured)
 - Modification: In many cases, able to use the path the astronaut took
 - Decreased computational requirements
 - Rover stays closer to astronaut (needs to stay within umbilical range)

Control Diagram

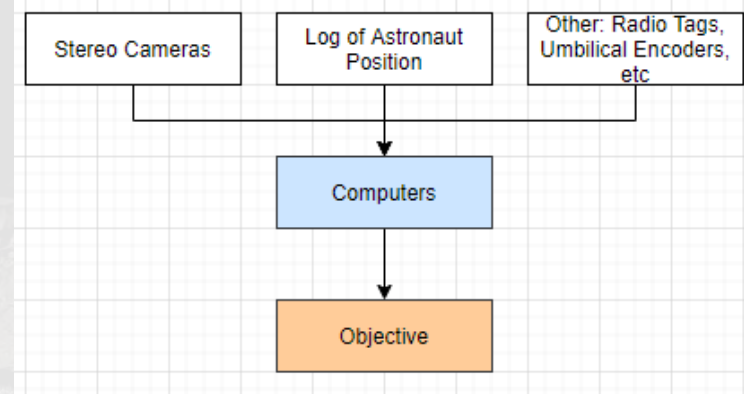

Operations Diagram

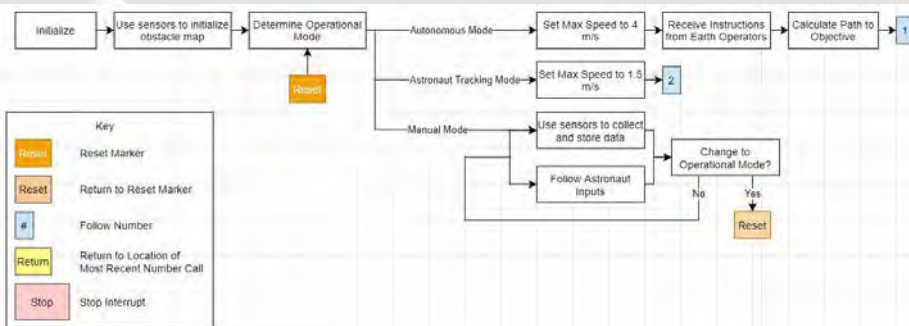

Operations Diagram – Autonomous

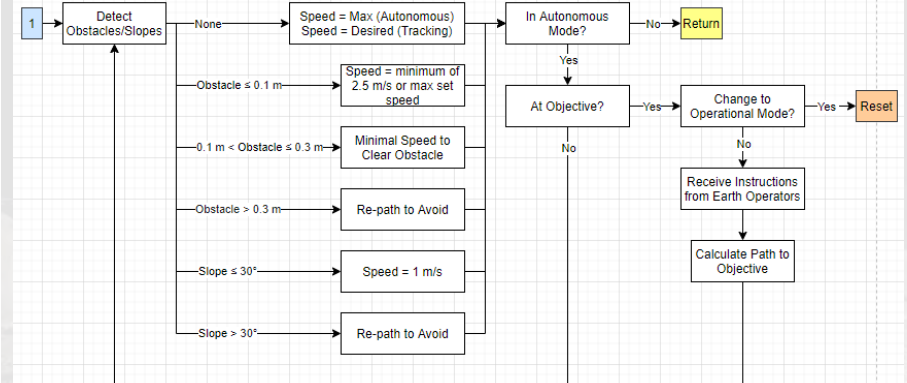

Operations Diagram – Tracking

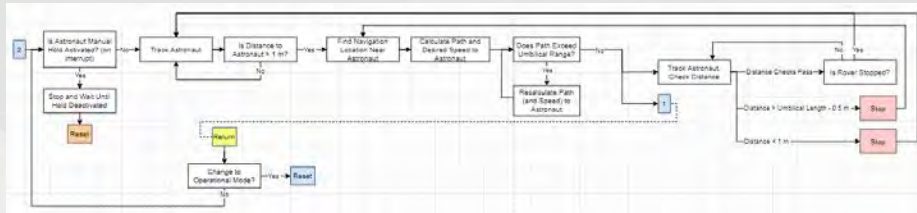

Power System Breakdown



System	Power Specifications
Motors (per each)	285 W @ 24 V for 2.5 m/s flat (0.85% efficiency assumed) 568 W @ 24 V for peak draw (from sample motor)
LIDAR	5-10 W
Cameras (per each)	~ 2 W
Computer System	15 - 30 W
Transmitter/Receiver	15 W
Life Support	50 W
Total Capacity (assuming 6 hours of driving for 54 km requirement)	~ 8000 Wh

Batteries



- For 54 km operation at 2.5 m/s, need 8 kWhrs of battery capacity for a single sortie
- For 30% margin and 90% discharge efficiency, need 10.5 kWhrs
- 10.5 kWhr requires around 65 kg based on mass estimation (Li-ion)
 - 175 Wh/kg energy density
 - 300 Wh/L volume density
- Note: likely overestimate due to conservative nature of terramechanics analysis

Batteries (continued)



- 6 hours of driving on an 8 hour EVA unlikely based on Apollo data
- Apollo data shows approximately 40% of time spent driving
- This changes requirement to 5 kWhrs, or 6.5 kWhrs with 30% margin and 90% discharge efficiency
- Required mass: ~ 40 kg based on mass estimation relation
- LRV had approximately 8.7 kWhrs, although had a higher margin (https://nssdc.gsfc.nasa.gov/planetary/lunar/apollo_lrv.html)

Brief Mass Budget



Link to Detailed Mass Budget	Mass (kg)	Number	Total (kg)
Mobility System			
Wheels/Wheel Peripherals	10.78	4	43.12
Motors	0.51	4	2.04
Gearbox	0.42	4	1.68
Suspension	5.96	4	23.82
Other			
Structure	50	1	50
LIDAR	0.15	1	0.15
Cameras	0.4	6	2.4
Batteries	65	1	65
Computer System	0.5	3	1.5

Total rover empty mass: 226.64 kg -> 10.3% margin

Earth Analog



4 Wheels, Slip = 0.5 Earth Terramechanics Analysis

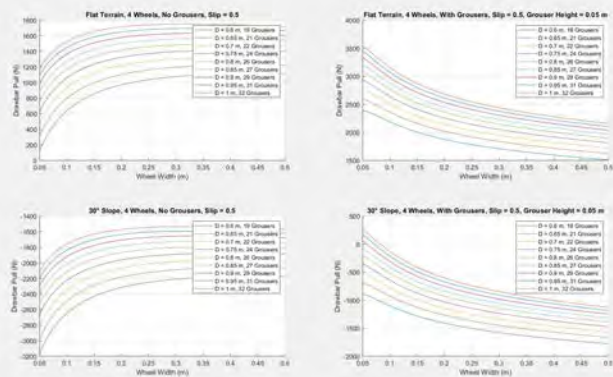

Earth Average Required Torque Per Wheel, $s = 0.5$

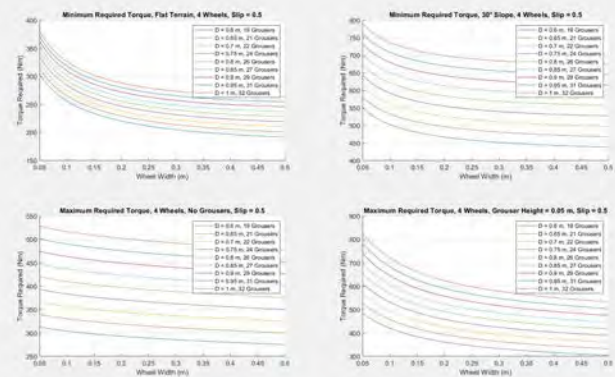

Earth Average Required Power Per Wheel, $s = 0.5$

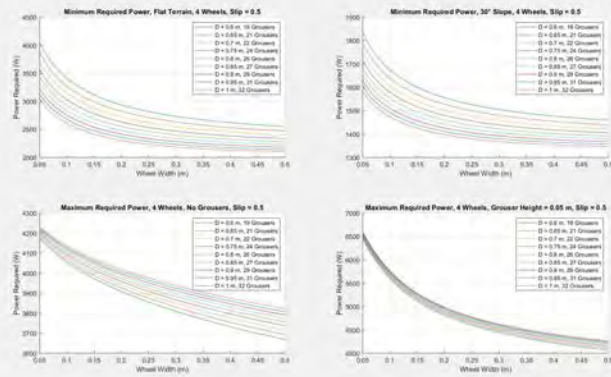

Earth Terramechanics Conclusions



- According to the terramechanics analysis, we need more torque and power than small car, which is likely incorrect
- Approximations are much less accurate than on the Moon
 - Terrain is much less uniform than on the Moon (sand, soil, rock, grass, etc.)
 - Approximations used in the terramechanics analysis are more applicable to the Moon than Earth
 - Terrain that is most likely to be encountered will probably have different properties than was assumed in the analysis
- Might need internal combustion to achieve design requirements for Earth analog, or very short run times for electric motors

Questions?



Modified, credit for original cartoon: poorlydrawnlines.com

Appendix



All the places we can go...

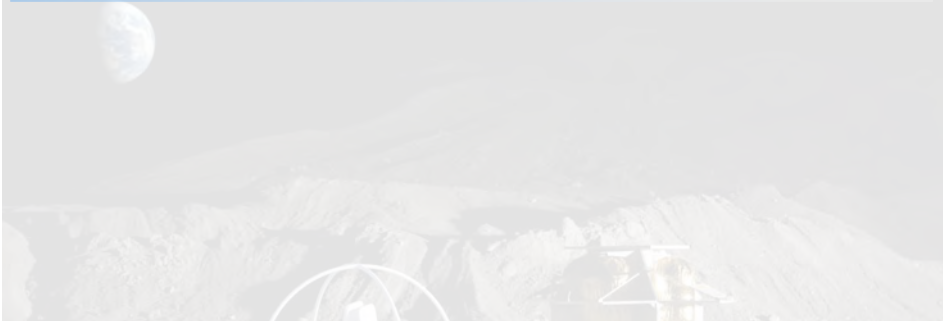

Ackermann Steering System Concept

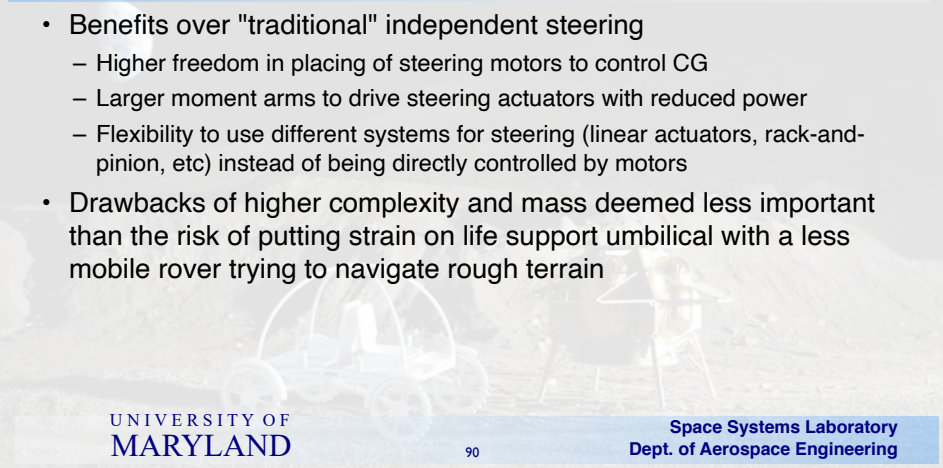

- Benefits over "traditional" independent steering
 - Higher freedom in placing of steering motors to control CG
 - Larger moment arms to drive steering actuators with reduced power
 - Flexibility to use different systems for steering (linear actuators, rack-and-pinion, etc) instead of being directly controlled by motors
- Drawbacks of higher complexity and mass deemed less important than the risk of putting strain on life support umbilical with a less mobile rover trying to navigate rough terrain

Drive System Design: Concepts Explored



Out-board motors vs in-board motors and driveshaft

- Do not want out-board motors to stick out beyond wheel width, hindering operations over rough terrain
- Motors housed in the wheel-hub for independent wheel drive were considered for harmonic drive motors, but planetary gear motors were too long
- Difficult to find high-torque motor and gears that were space-efficient
- In-board motors would require complicated power transmission design with active suspension system

Motor Stats

- RBE-02112
- 50:1 Harmonic

RBE(H) Motor Series		RBE(H) 02110 MOTOR SERIES PERFORMANCE DATA																		
Motor Parameters		Symbol	Units	02109	02110	02111	02112	02113	02114	02115										
Max Cont. Output Power at 21°C amb	W	P _{Cont}	W	8120	8412	8761	9161	9561	9944	10317										
	W	P _{Peak}	W	241	261	281	298	315	334	353										
Speed at Rated Power	N/Min	N _{Rated}	RPM	1000	1242	1500	1500	1875	2170	2620										
	N/Min	N _{Max}	RPM	12000	12000	12000	12000	12000	12000	12000										
Continuous Full Torque at 21°C amb	Nm	T _{Cont}	Nm	0.701	1.11	1.57	1.97	2.50	2.88	3.50										
	Nm	T _{Peak}	Nm	0.852	1.47	2.40	2.40	2.40	3.46	4.70										
Peak Torque	Nm	T _p	Nm	1.87	3.37	5.10	6.80	8.81	10.2	12.2										
	Nm	T _{st}	Nm	2.55	4.97	6.92	8.22	11.2	13.8											
Max Torque	Nm	T _{st}	Nm	2.48	2.58	2.72	2.90	3.17	3.49											
	Nm	T _{st}	Nm	1.72	1.47	1.38	0.78	0.94	1.12											
Motor Constant	V/Hz	K _v	V/Hz	0.102	0.117	0.143	0.143	0.187	0.147	0.147										
	V/Hz	K _v	V/Hz	0.138	0.237	0.179	0.196	0.147	0.147											
Thermal Resistance*	°C/W	R _{th}	°C/W	1.70	1.40	1.30	1.40	1.30	1.30											
	°C/W	R _{th}	°C/W	1.643-01	1.548-01	1.348-01	1.428-01	1.428-01	1.348-01	1.348-01										
Max Rate Position	°/s	N _{max}	°/s	1.418-01	1.318-01	1.178-01	1.178-01	1.418-01	1.318-01	1.178-01										
	°/s	N _{max}	°/s	0.824	0.812	0.817	0.817	0.817	0.817											
Max Output Torque	Nm	T _{out}	Nm	0.915	0.871	0.894	0.894	0.915	0.915											
	Nm	T _{out}	Nm	0.916	0.919	0.919	0.919	0.916	0.916											
Peak to Peak	Nm	T _{pp}	Nm	0.822	0.813	0.883	0.811	0.811	0.811											
	Nm	T _{pp}	Nm	1.358-01	1.108-01	1.408-01	1.408-01	1.108-01	1.108-01											
Efficiency	%	η	%	74.8	72.7	73.7	73.7	74.8	74.8											
	%	η	%	74.8	72.7	73.7	73.7	74.8	74.8											
No. of Poles	P	P	P	12	12	12	12	12	12											
	P	P	P	12	12	12	12	12	12											
Winding Connection		Symbol	Units																	
Current at Cont. Torque	A	I _{Cont}	A	3.34	2.19	1.818	1.713	1.27	0.974	1.42	2.17	0.810	1.07	1.07	0.848	0.813	0.95	1.07	1.07	1.17
	A	I _{Peak}	A	21.7	19.9	40.2	21.3	19.9	40.2	21.3	19.9	40.2	21.3	19.9	40.2	21.3	19.9	40.2	21.3	19.9
Torque Sensitivity	Nm/A	K _t	Nm/A	0.110	0.307	0.900	0.210	0.196	0.112	0.141	0.111	0.204	0.424	0.14	0.172	0.141	0.124	0.141	0.124	0.141
	Nm/A	K _t	Nm/A	0.109	0.306	0.899	0.210	0.196	0.112	0.141	0.111	0.204	0.424	0.14	0.172	0.141	0.124	0.141	0.124	0.141
Back EMF constant	V/Hz	K _e	V/Hz	1.61	0.816	0.816	1.19	1.19	1.19	1.19	1.19	1.19	1.19	1.19	1.19	1.19	1.19	1.19	1.19	1.19
	V/Hz	K _e	V/Hz	1.61	0.816	0.816	1.19	1.19	1.19	1.19	1.19	1.19	1.19	1.19	1.19	1.19	1.19	1.19	1.19	1.19
Motor Resistance	Ω	R _m	Ω	1.27	0.6479	1.68	1.68	1.68	1.68	1.68	1.68	1.68	1.68	1.68	1.68	1.68	1.68	1.68	1.68	1.68
	Ω	R _m	Ω	1.27	0.6479	1.68	1.68	1.68	1.68	1.68	1.68	1.68	1.68	1.68	1.68	1.68	1.68	1.68	1.68	1.68
Motor Inductance	mH	L _m	mH	1.7	1.0	0.60	0.25	1.1	1.1	1.1	1.1	1.1	1.1	1.1	1.1	1.1	1.1	1.1	1.1	1.1
	mH	L _m	mH	1.7	1.0	0.60	0.25	1.1	1.1	1.1	1.1	1.1	1.1	1.1	1.1	1.1	1.1	1.1	1.1	1.1



Lunar Terramechanics Graphs

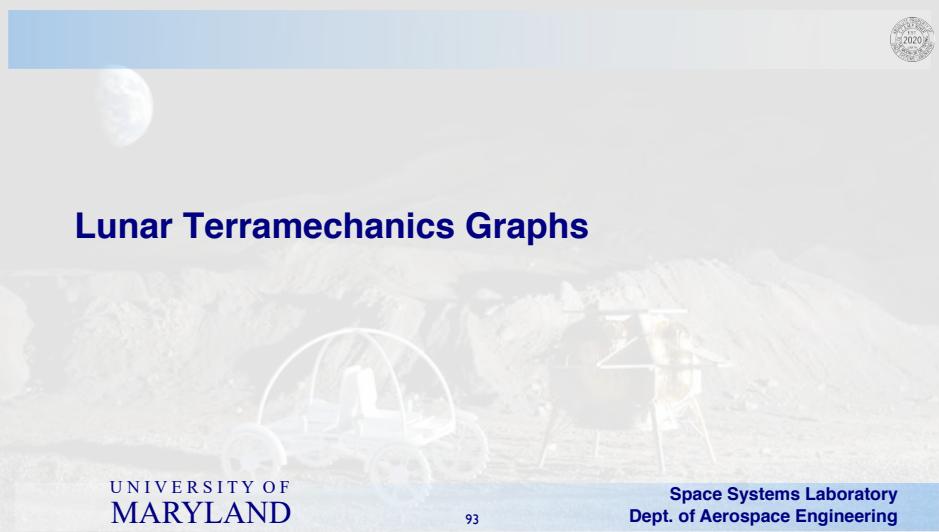

4 Wheels, Slip = 0.2 Terramechanics Analysis

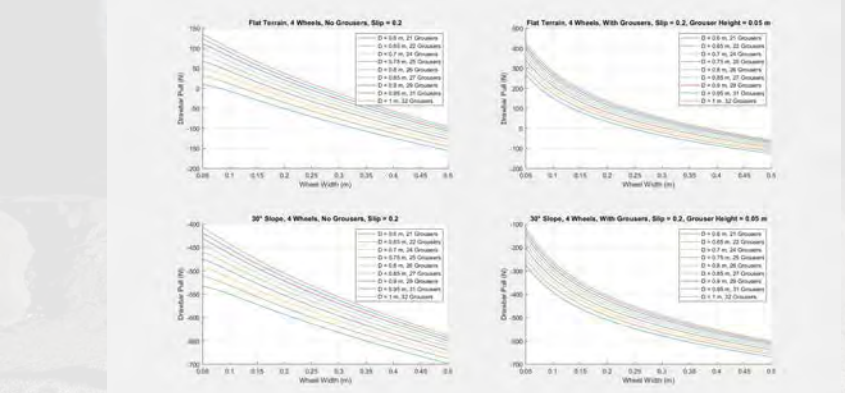

4 Wheels, Slip = 0.25 Terramechanics Analysis

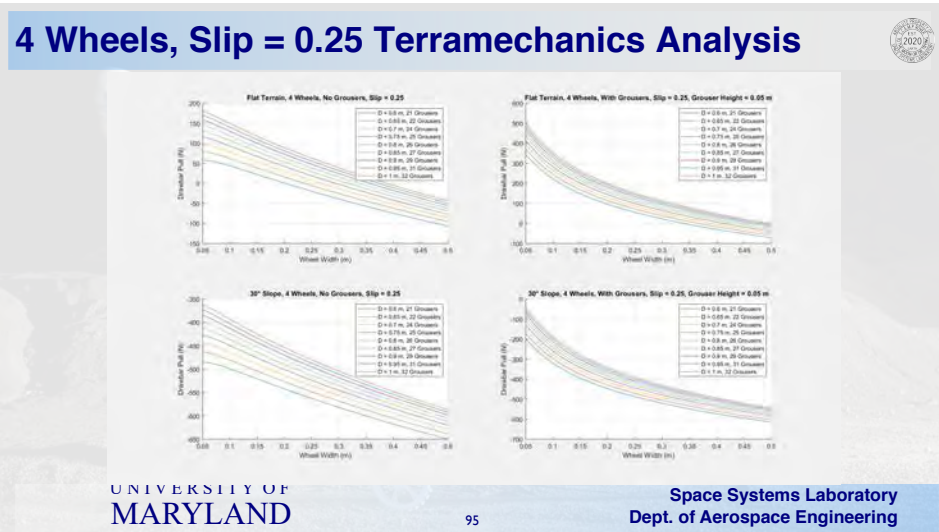

4 Wheels, Slip = 0.3 Terramechanics Analysis

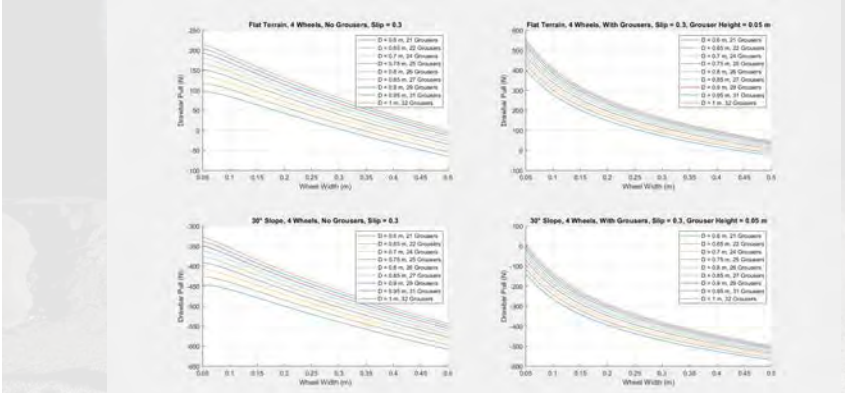

4 Wheels, Slip = 0.35 Terramechanics Analysis

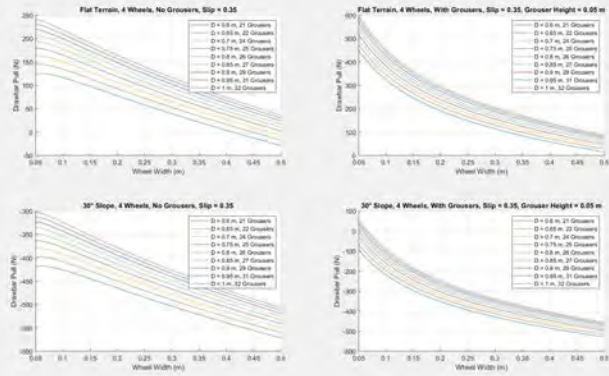

4 Wheels, Slip = 0.4 Terramechanics Analysis

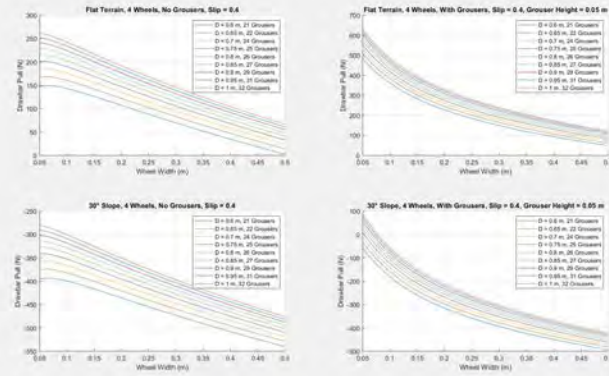

4 Wheels, Slip = 0.45 Terramechanics Analysis

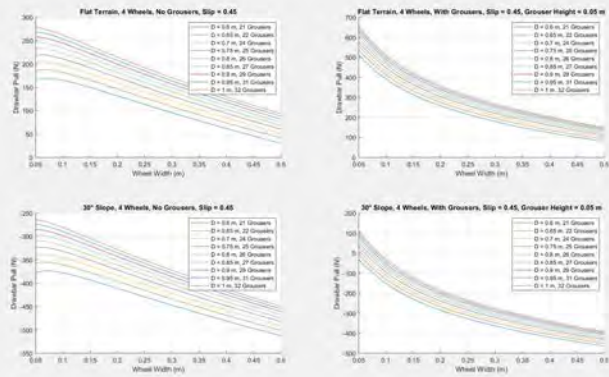

4 Wheels, Slip = 0.5 Terramechanics Analysis

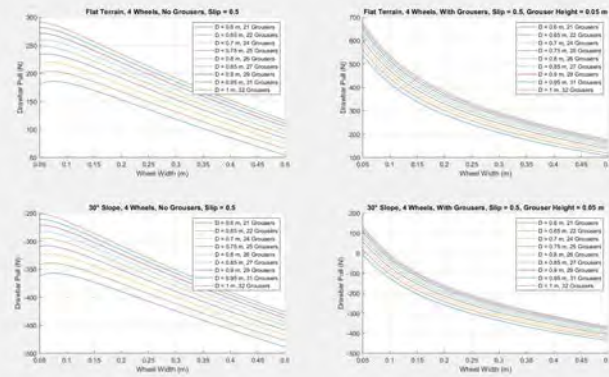

6 Wheels, Slip = 0.2 Terramechanics Analysis

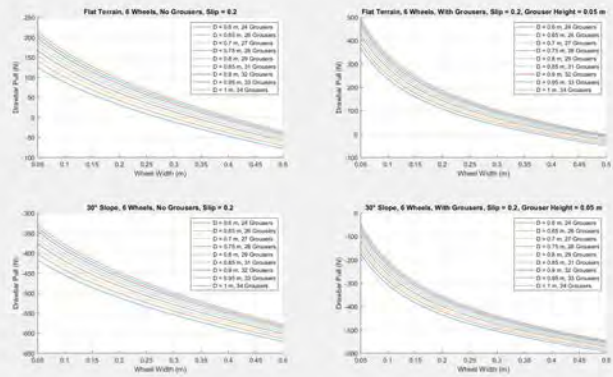

6 Wheels, Slip = 0.25 Terramechanics Analysis

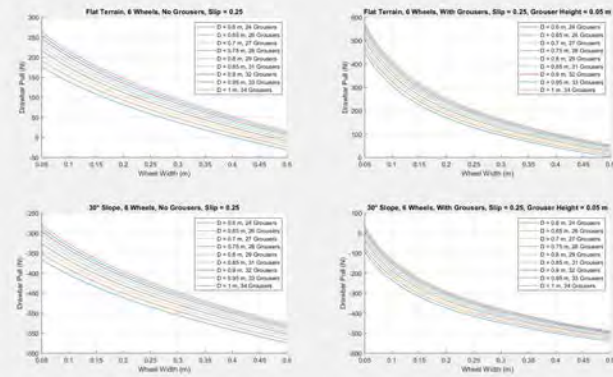

6 Wheels, Slip = 0.3 Terramechanics Analysis

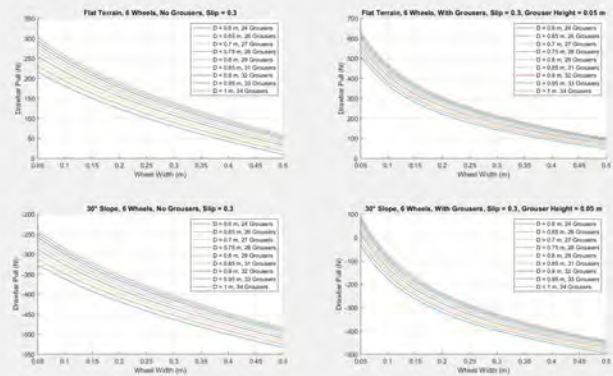

6 Wheels, Slip = 0.35 Terramechanics Analysis

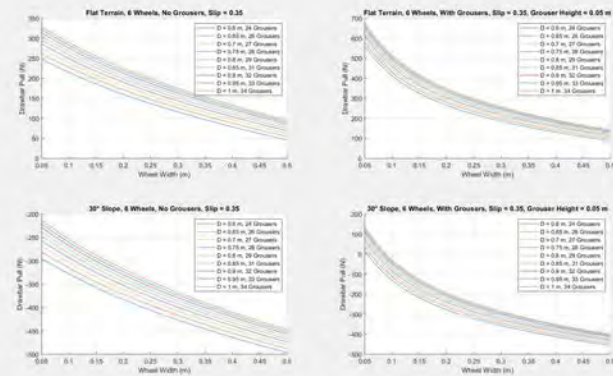

6 Wheels, Slip = 0.4 Terramechanics Analysis

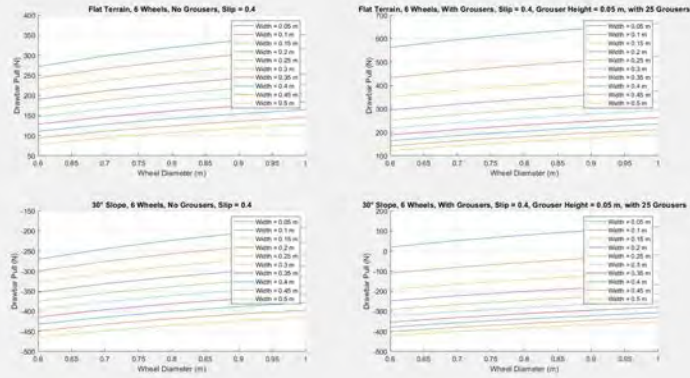

6 Wheels, Slip = 0.45 Terramechanics Analysis

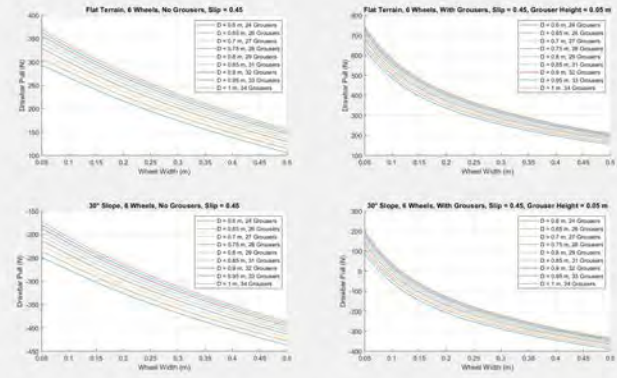

6 Wheels, Slip = 0.5 Terramechanics Analysis

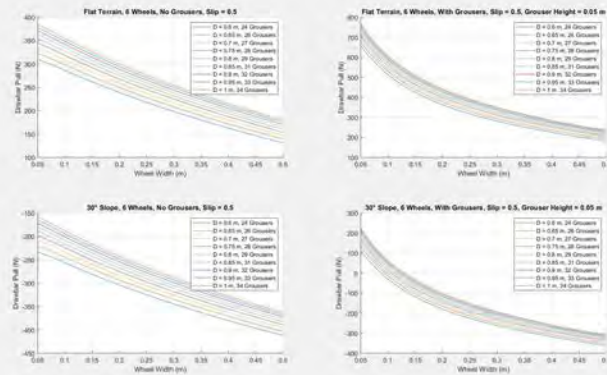

6 Wheels, 4 Driven, Slip = 0.2 Terramechanics Analysis

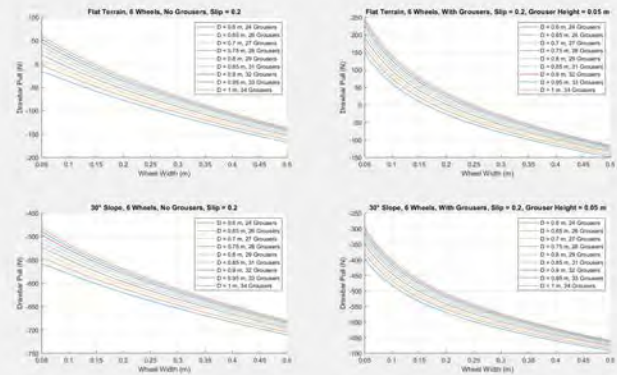

6 Wheels, 4 Driven, Slip = 0.25 Terramechanics Analysis

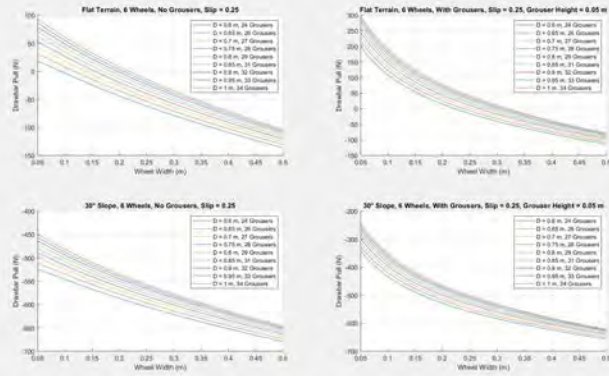

6 Wheels, 4 Driven, Slip = 0.3 Terramechanics Analysis

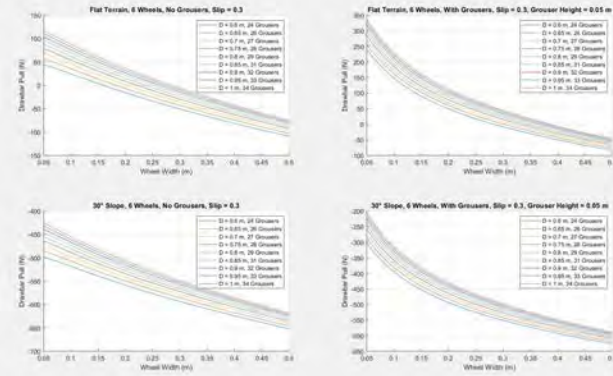

6 Wheels, 4 Driven, Slip = 0.35 Terramechanics Analysis

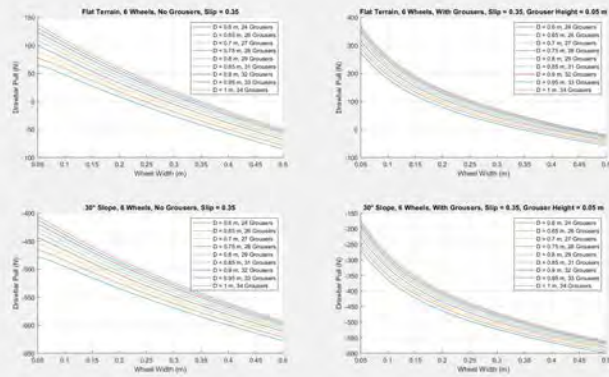

6 Wheels, 4 Driven, Slip = 0.4 Terramechanics Analysis

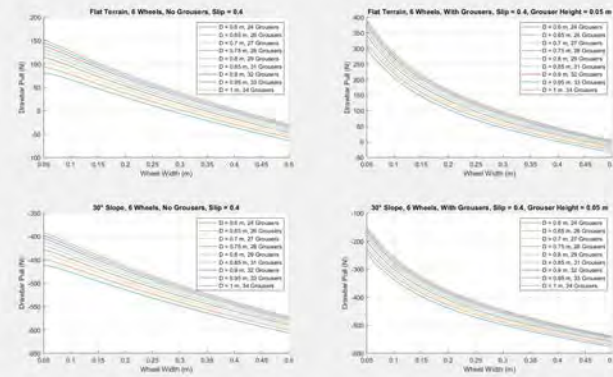

6 Wheels, 4 Driven, Slip = 0.45 Terramechanics Analysis

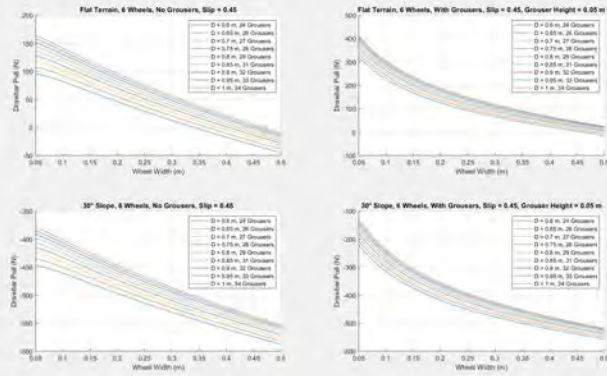

6 Wheels, 4 Driven, Slip = 0.5 Terramechanics Analysis

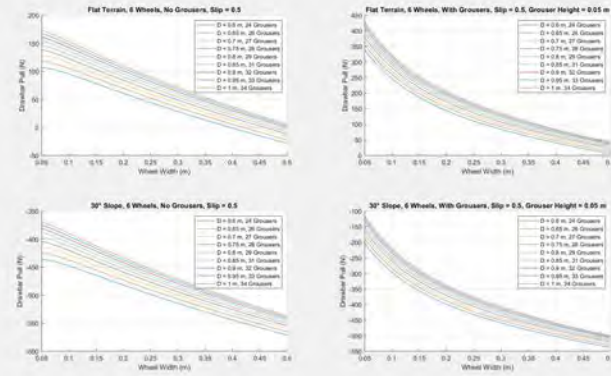

Earth Terramechanics Graphs

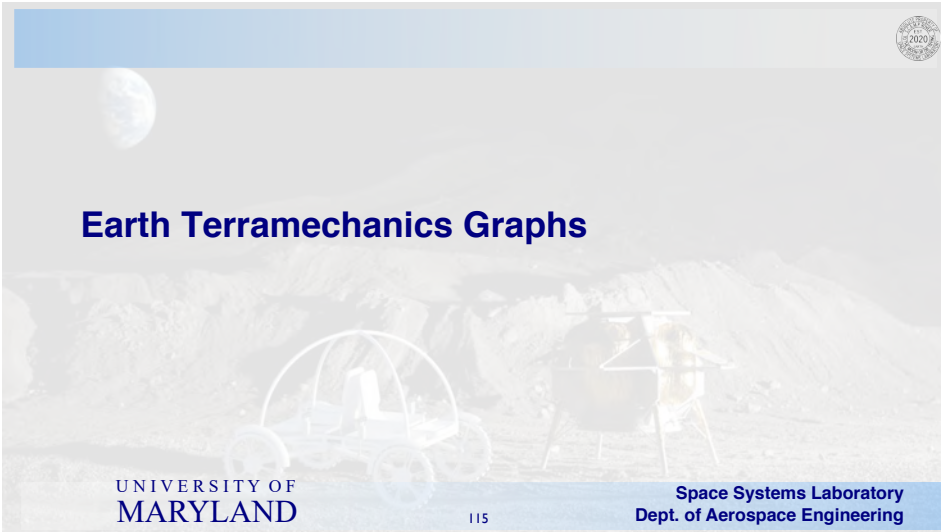

4 Wheels, Slip = 0.2 Earth Terramechanics Analysis

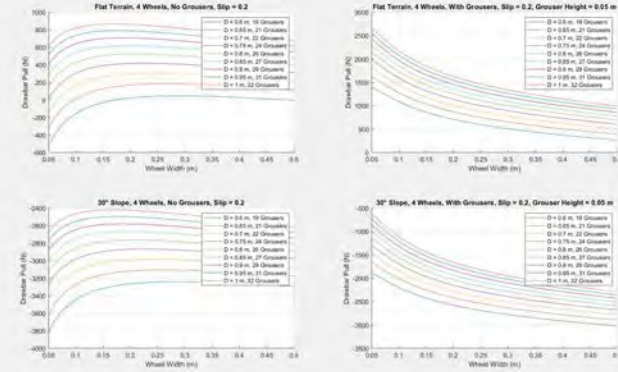

4 Wheels, Slip = 0.3 Earth Terramechanics Analysis

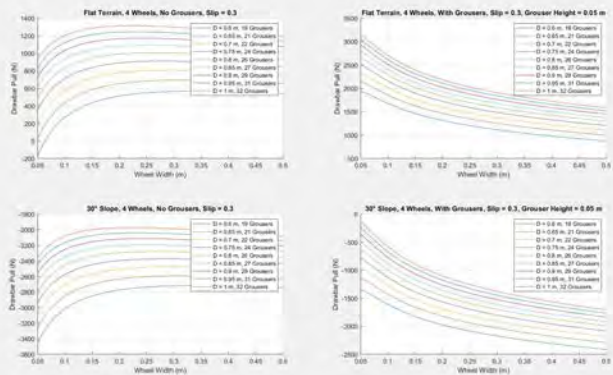

4 Wheels, Slip = 0.4 Earth Terramechanics Analysis

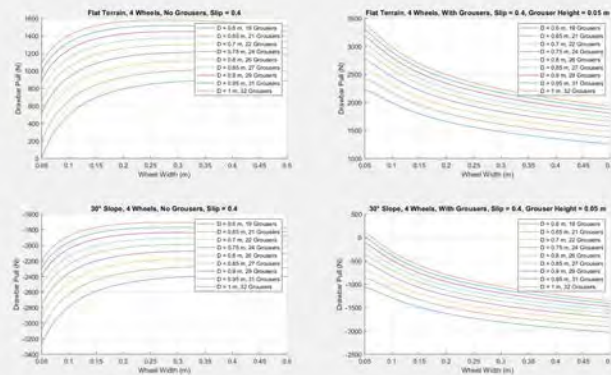

4 Wheels, Slip = 0.5 Earth Terramechanics Analysis

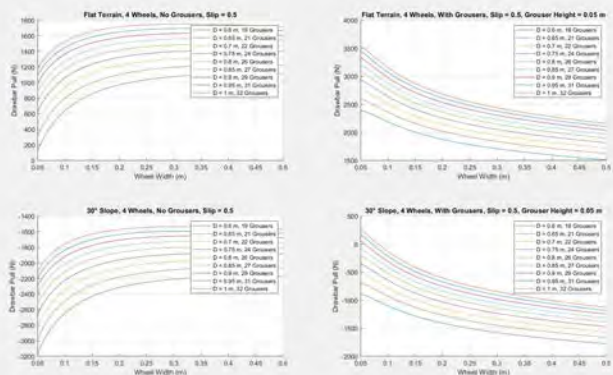

6 Wheels, Slip = 0.2 Earth Terramechanics Analysis

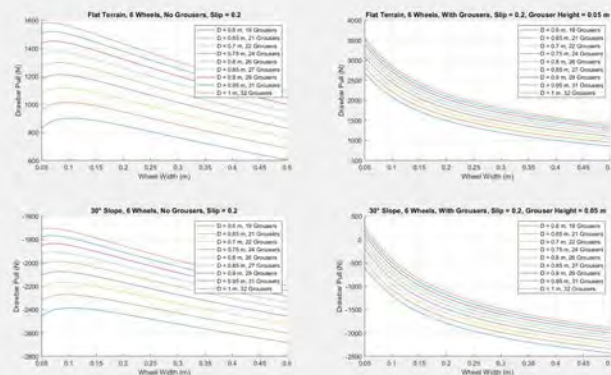

6 Wheels, Slip = 0.3 Earth Terramechanics Analysis

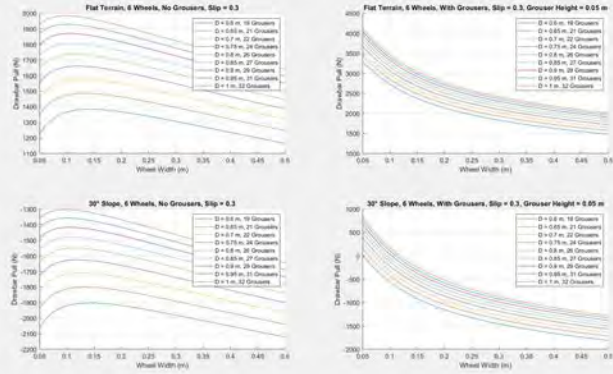

6 Wheels, Slip = 0.4 Earth Terramechanics Analysis

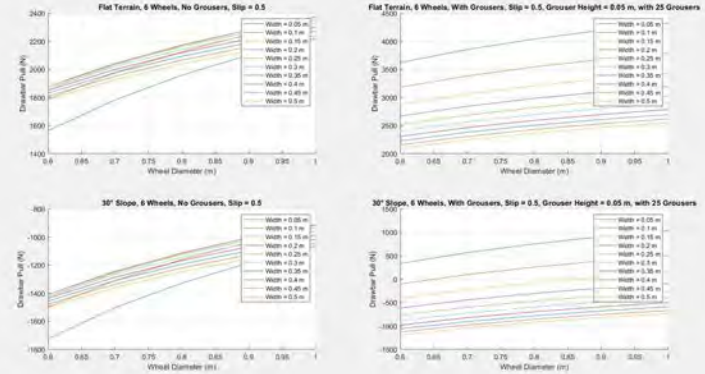

6 Wheels, Slip = 0.5 Earth Terramechanics Analysis

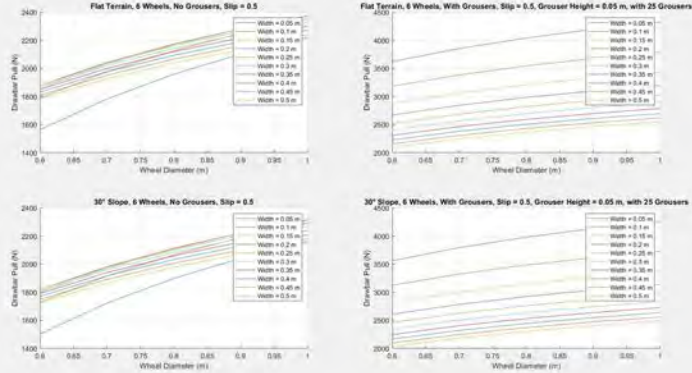

6 Wheels, 4 Driven, Slip = 0.2 Earth Terramechanics Analysis

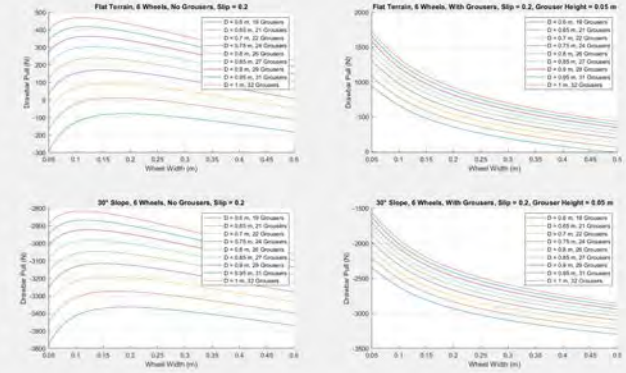

6 Wheels, 4 Driven, Slip = 0.3 Earth Terramechanics Analysis

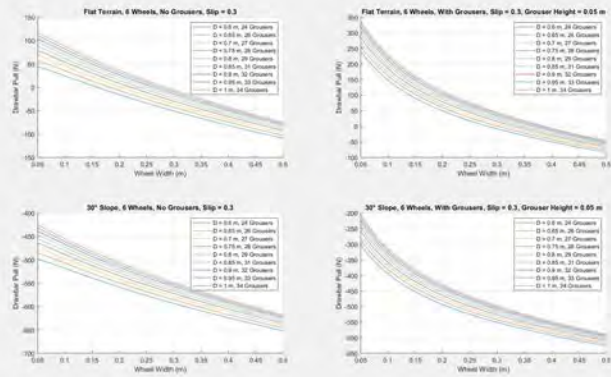

6 Wheels, 4 Driven, Slip = 0.4 Earth Terramechanics Analysis

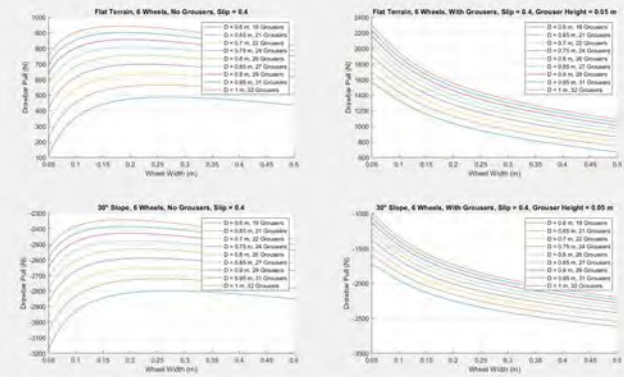

6 Wheels, 4 Driven, Slip = 0.5 Earth Terramechanics Analysis

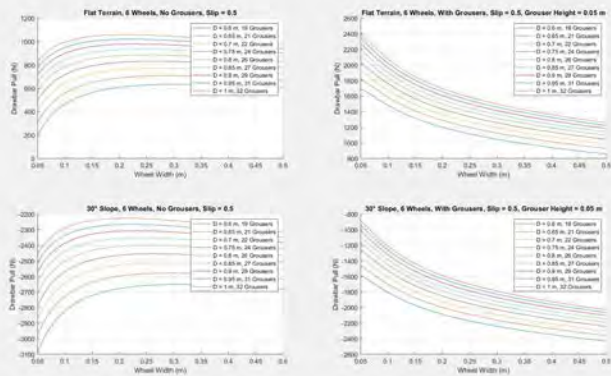

Required Torque Graphs

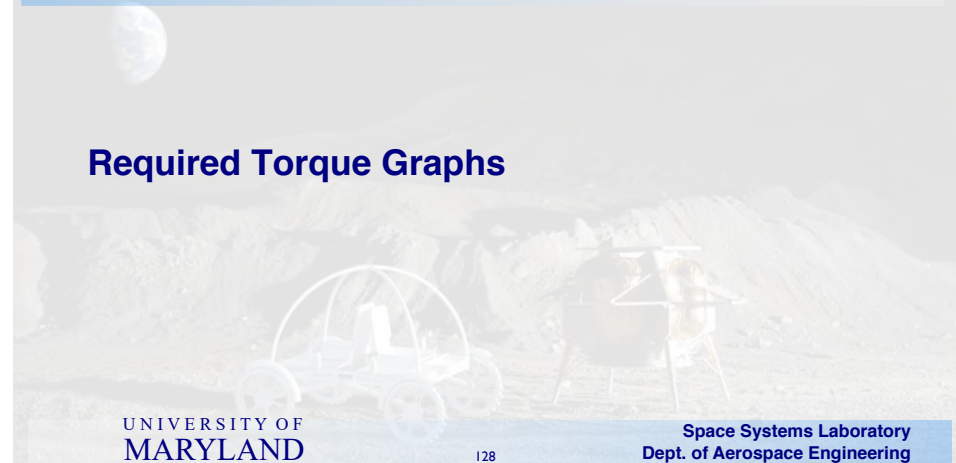

Average Required Torque Per Wheel, $s = 0.2$

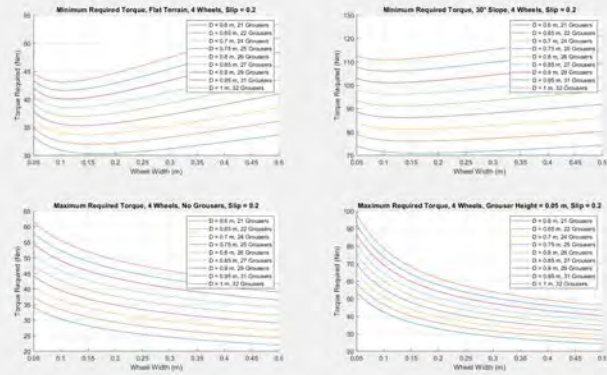

Average Required Torque Per Wheel, $s = 0.3$

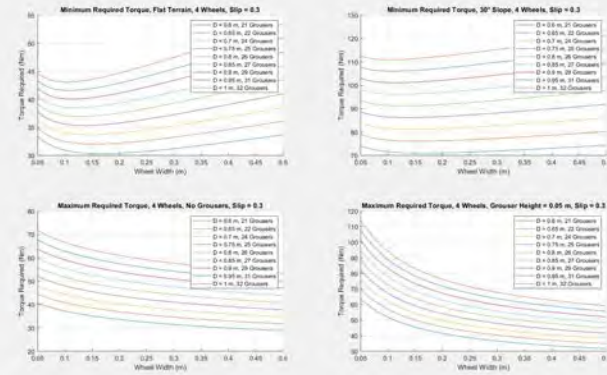

Average Required Torque Per Wheel, $s = 0.4$

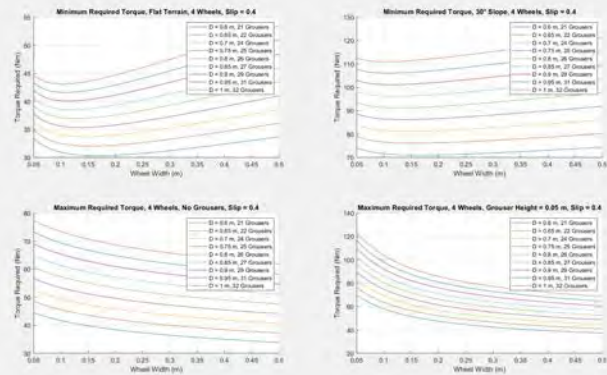

Average Required Torque Per Wheel, $s = 0.5$

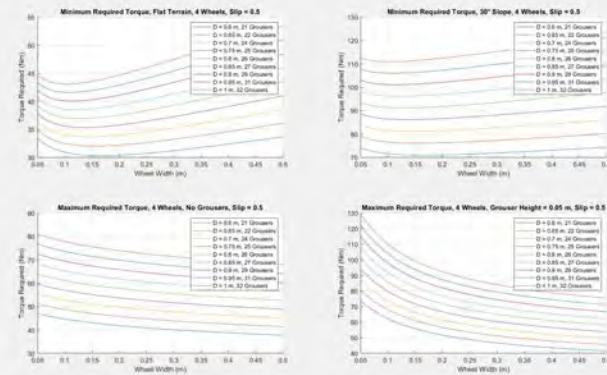

Earth Average Required Torque Per Wheel, $s = 0.2$

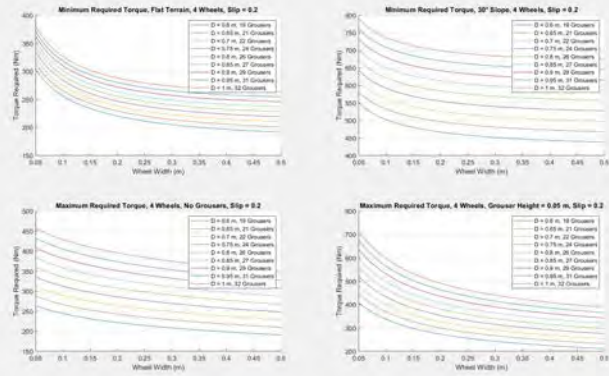

Earth Average Required Torque Per Wheel, $s = 0.3$

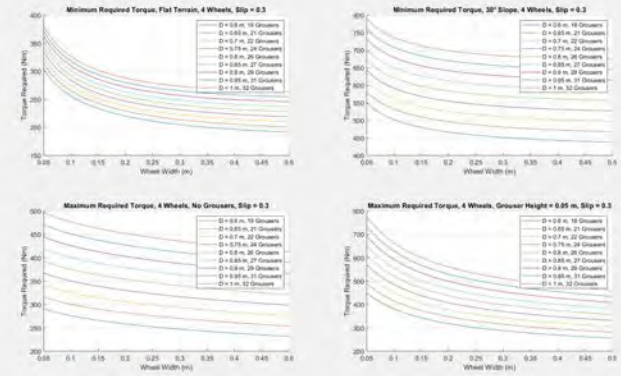

Earth Average Required Torque Per Wheel, $s = 0.4$

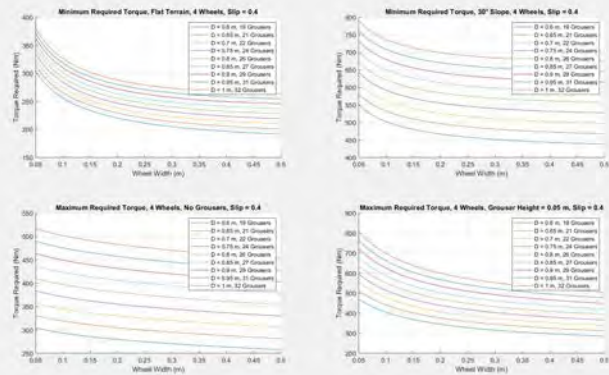

Earth Average Required Torque Per Wheel, $s = 0.5$

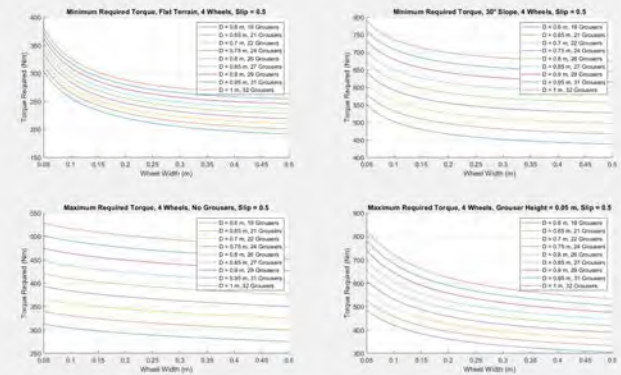



Required Power Graphs

Average Required Power Per Wheel, $s = 0.2$

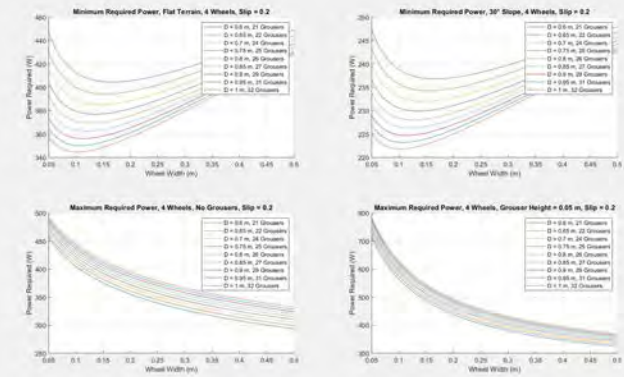

Average Required Power Per Wheel, $s = 0.3$

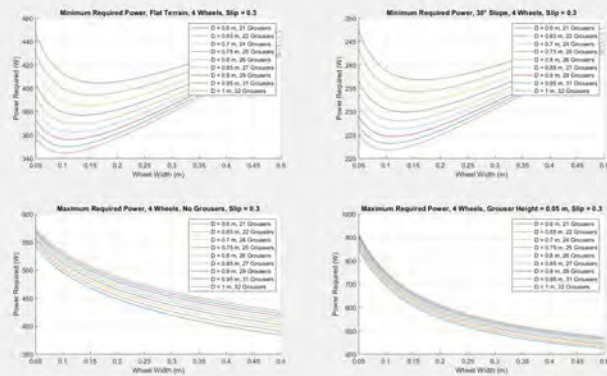

Average Required Power Per Wheel, $s = 0.4$

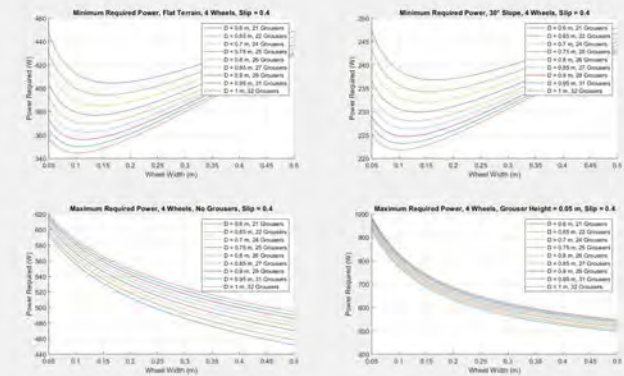

Average Required Power Per Wheel, $s = 0.5$

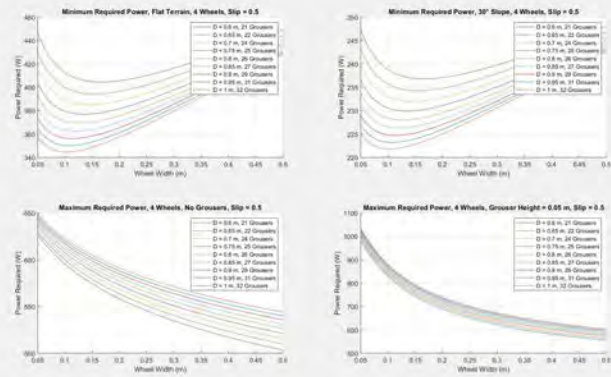

Earth Average Required Power Per Wheel, $s = 0.2$

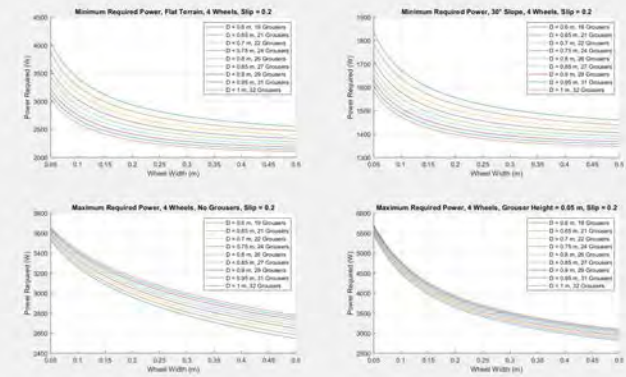

Earth Average Required Power Per Wheel, $s = 0.3$

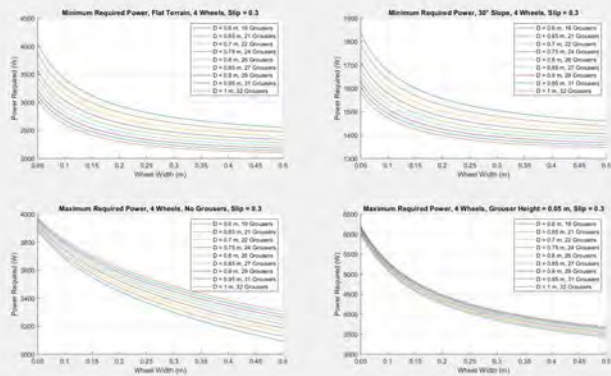

Earth Average Required Power Per Wheel, $s = 0.4$

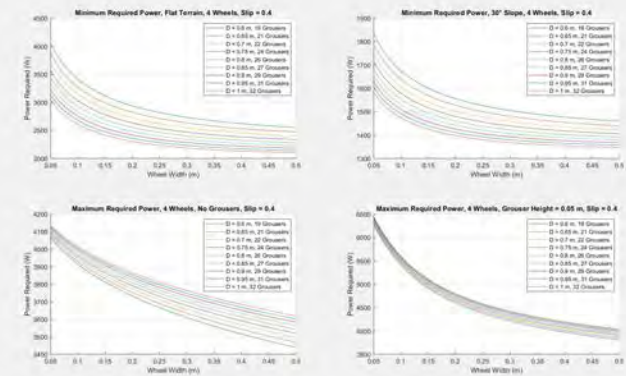

Earth Average Required Power Per Wheel, $s = 0.5$

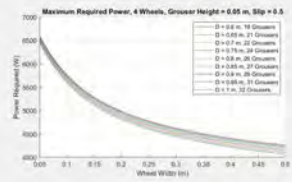
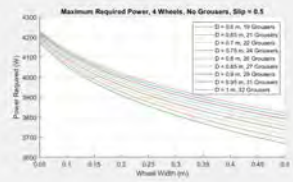
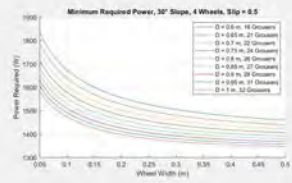
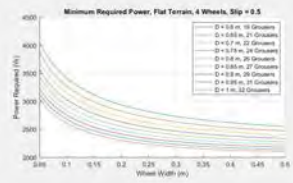



Development and Testing of a Minimum-Mass Unpressurized Crewed/Autonomous Rover

University of Maryland
Final Program Review

Moon to Mars Exploration Systems and
Habitat (M2M X-Hab) 2021
Academic Innovation Challenge

July 29, 2021

University of Maryland Personnel

- Dr. David L. Akin
Director, Space Systems Laboratory
Associate Professor of Aerospace Engineering
- Graduate Researchers
 - Daniil Gribok
 - Charles Hanner
 - Zachary Lachance
- Undergraduate Students
 - Nicolas Bolatto
 - Amelia Cherian
 - Robert Fink
 - Joshua Martin
 - Tal Ullmann
- ENAE 788X: Planetary Surface Robotics Design Teams
 - Initial designs and input into final design

Problem Statement

- Lunar EVAs are constrained by range
 - Limited walk-back distance of astronauts
 - Regions of scientific interest likely far from landing-friendly base/habitat sites
 - Transportation method required to moderate physiological workload
 - Physical strain of carrying PLSS
- Single-person human/autonomous unpressurized rover for improving lunar exploration transportation
 - Autonomous exploration before and after human mission
 - Increase operational range of EVA's and data collection
 - Provide astronaut support and instrument/samples transport
 - Capable of carrying second crew in contingency (adds redundancy for enhanced crew safety)
 - Low mass for transport via CLPS or as secondary payload for human lander

2010: Raven at Desert RATS



UNIVERSITY OF
MARYLAND

Rover Design Paradigm

- Four 3-4 person teams in ENAE 788X (graduate course in Planetary Surface Robotics) independently designed lightweight rovers for lunar conditions
- Best features of each design were combined in second-generation design process, and modified to accommodate Earth gravity conditions
- Rover will be built and tested as a precursor to use in analog field testing
- Lunar-specific requirements which are not compatible with Earth version noted with *

Level 1 Requirements (Performance)

- 1) Rover shall have a maximum operating speed of at least 4 m/sec on level, flat terrain.
- 2) Rover shall be designed to accommodate a 0.3 meter obstacle at minimal velocity.
- 3) Rover shall be designed to accommodate a 0.1 m obstacle at a velocity of 2.5 m/sec.
- 4) Rover shall be designed to safely accommodate a 20° slope in any direction at a speed of at least 1 m/sec and including the ability to start and stop.
- 5) The rover shall have a nominal sortie range of 54 km* at an average speed of 2.5 m/sec.

Level 1 Requirements (Payload)

- 6) Rover shall be capable of carrying one 170 kg EVA crew and 80 kg of assorted payload in nominal conditions.
- 7) Payload may be modeled as a 0.25 m³ box
- 8) Rover shall be capable of also carrying a second 170 kg EVA crew in a contingency situation. Payload may be jettisoned if design permits.
- 9) Rover design shall incorporate roll-over protection for the crew and all required ingress/egress aids and crew restraints.

Level 1 Requirements (Operations)

- 10) A nominal sortie shall be at least eight hours long*.
- 11) Two rovers must be capable of launch and delivery on a single CLPS lander.
- 12) A single rover shall mass ≤ 250 kg*.
- 13) Rovers shall be developed in time to be used on the first Artemis landing mission.
- 14) Rover shall be capable of operating indefinitely without crew present*.

Level 1 Requirements (GN&C)

- 15) Rover shall be capable of being controlled directly, remotely, or automated.
- 16) Rover shall be capable of following an astronaut, following an astronaut's path, or autonomous path planning between waypoints.
- 17) Rover shall be capable of operating during any portion of the lunar day/night cycle and at any latitude*.

Preferred System Solution Definition

- Major trade studies – parallel design studies considering critical design options
 - Wheels: size, numbers, shape, grousers
 - Suspension: none, independent, rocker/bogey, articulated body, active
 - Steering: skid-steer, Ackermann, all-wheel steer, crab drive
- Concurrent development
 - Hub motor/gearbox design and fabrication
 - Electronics prototyping and testing on RMP-440/RAVEN

Preliminary Functional Breakdown (1)

- Mobility chassis
 - Basic functionality (driving, parking, recharge)
 - Maintainability
 - Stowage for economical packing/shipping
- Crew interfaces
 - Suit-specific seating (accommodate backpack, provide easy-to-use body restraints)
 - Driving controls (forward/back/turn, brake)
 - Displays (navigation, systems status, instruments)
 - Accommodations for second crew in contingency

Preliminary Functional Breakdown (2)

- Payload interfaces
 - Sampling manipulator mount and wiring
 - Geological tools
 - Sample collection and curation
 - Science instruments
- Operational features
 - Lighting (headlights, task lighting, running lights)
 - Sensor platforms (sensor arch/bridge/mast)
 - Vision systems (AprilTags tracking)
 - Advanced sensor scans (scanning laser rangefinder, LIDAR)

Draft Concept of Operations

- Synthesize a "best practices" design from multiple design studies as described above
- Fabricate and assemble a prototype rover
- Test against performance requirements
- Perform EVA/rover operations studies in UMD "Moonyard" using MX-series spacesuit simulators (completing X-Hab 2021)
- Find candidate locations for more elaborate local field tests (tie-in to GEODES SSERVI)
- Incorporate into GEODES field tests in Lava Fields National Monument in California (summer 2021)

Overview of ENAE 788X Designs

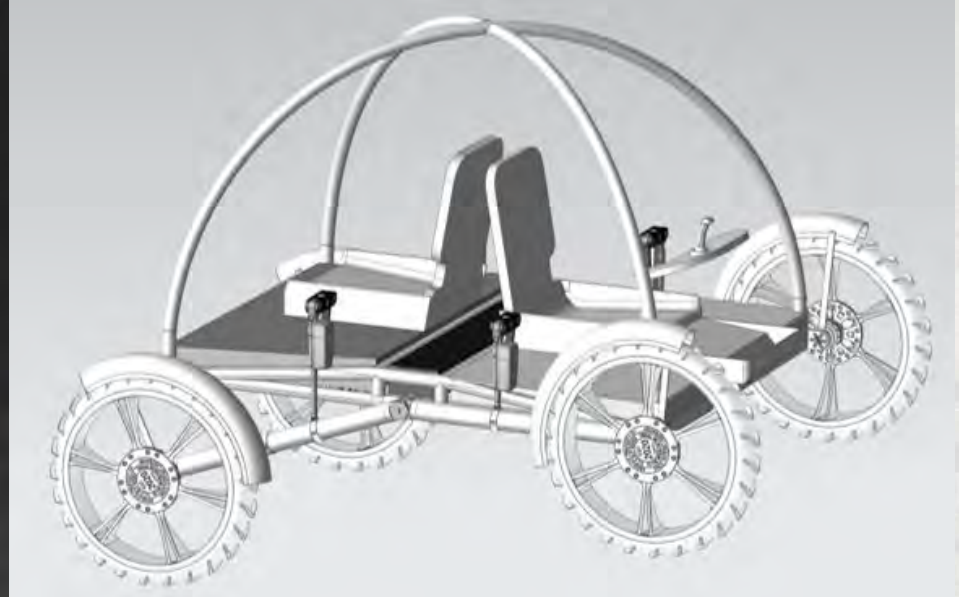
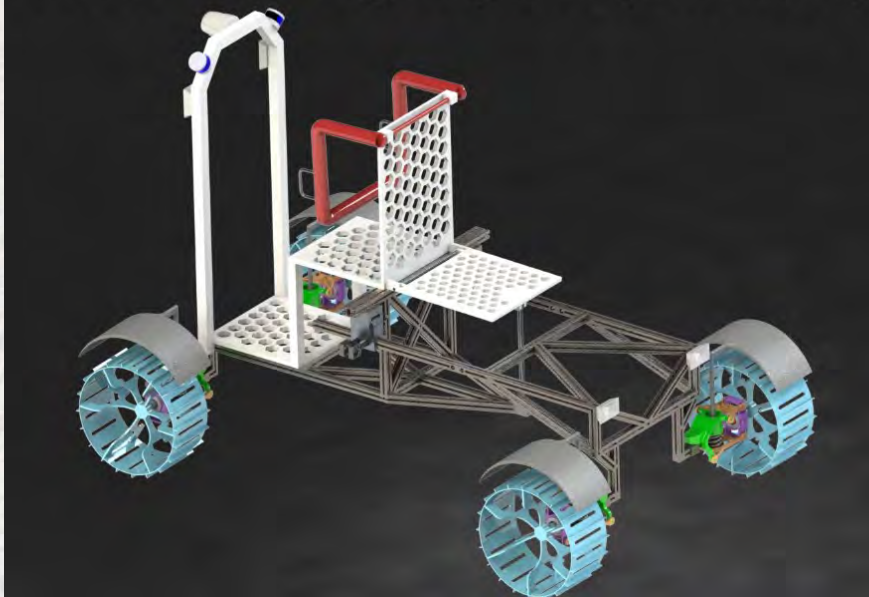
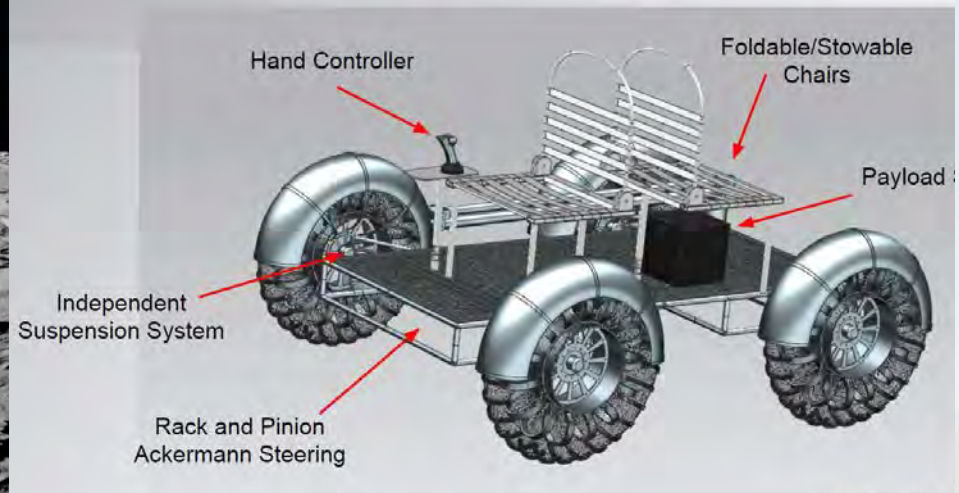
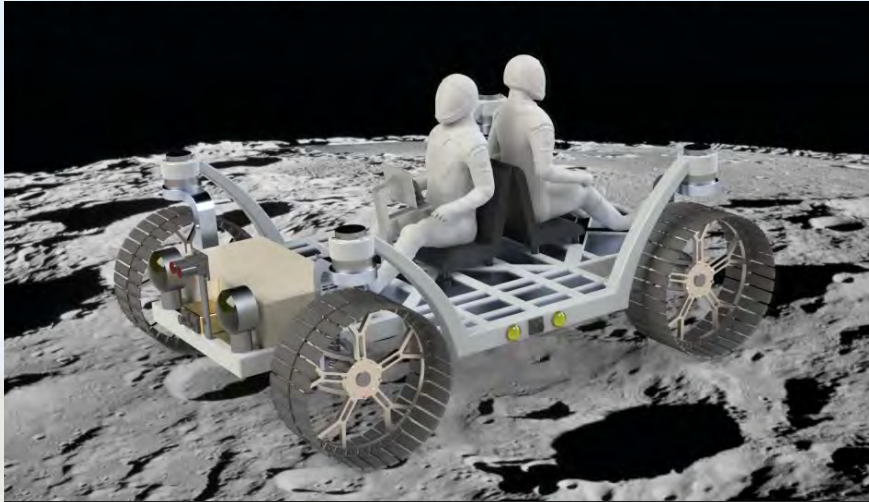

ENAE 788X Designs - SCAMP

Fore/Aft Slope Stability (side view)

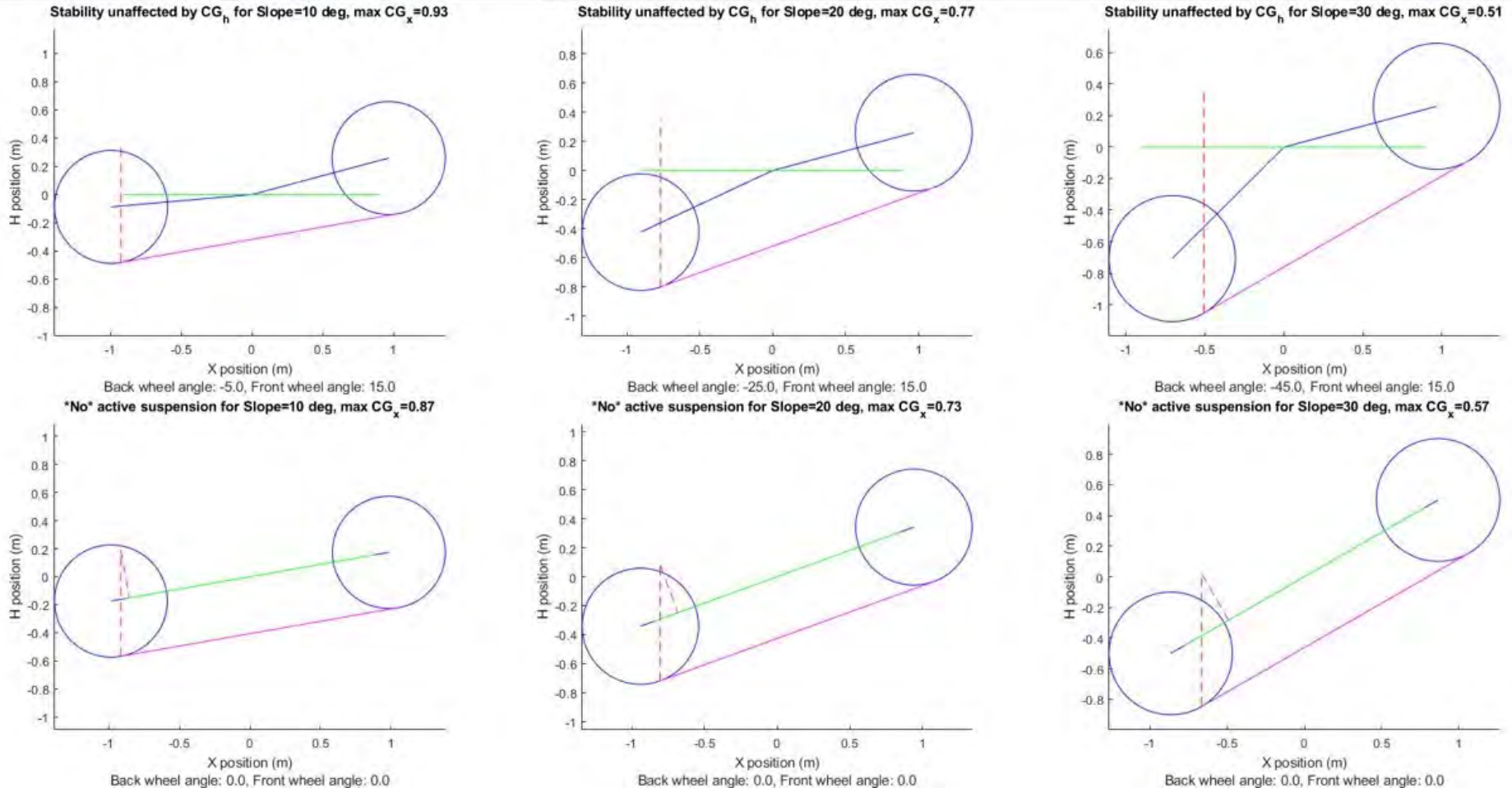

ENAE 788X Designs - SCAMP

Roll Slope Stability (front view)

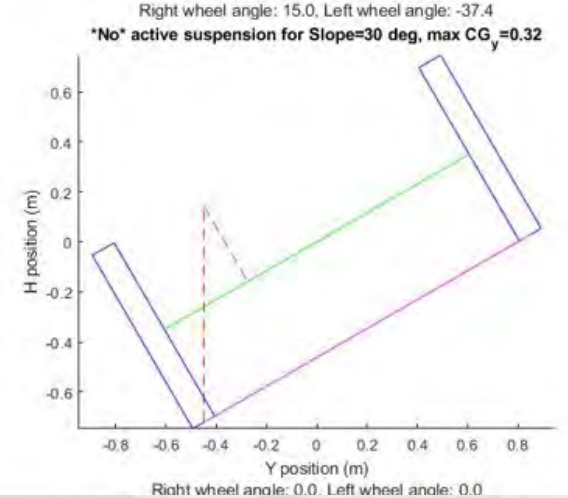
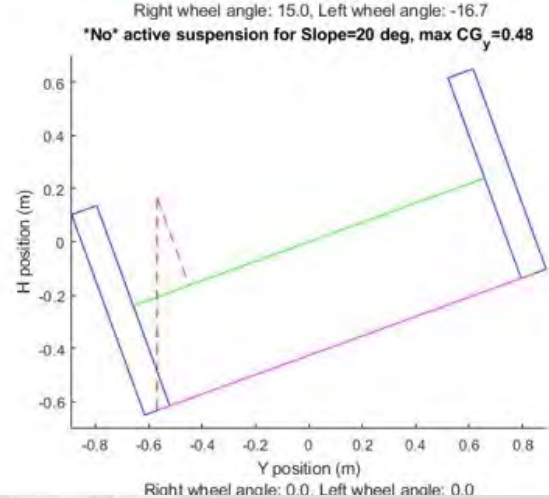
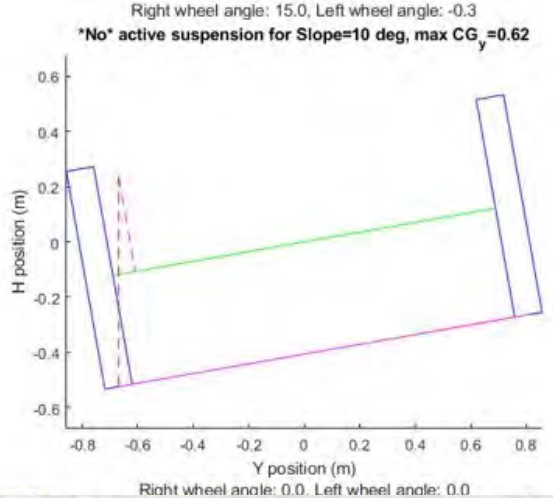
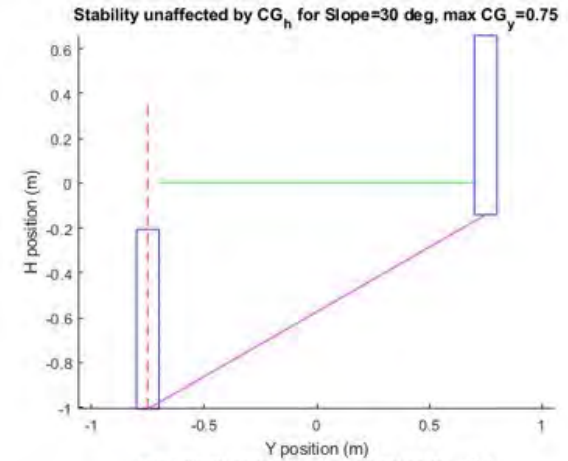
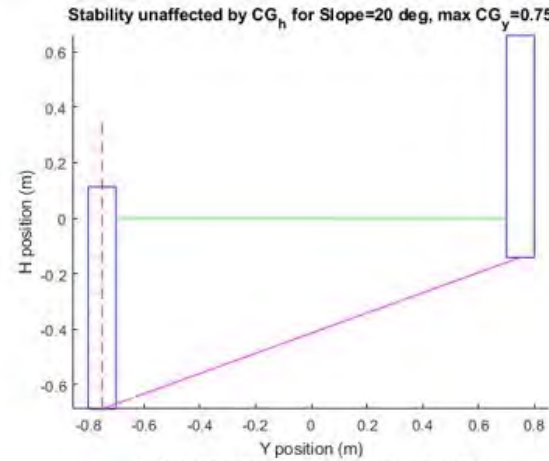
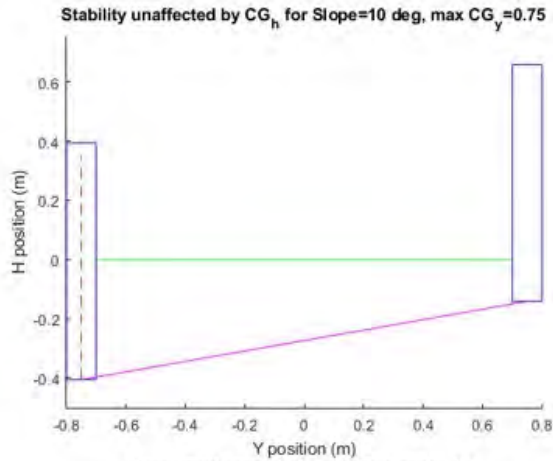

ENAE 788X Designs - SCAMP

Stopping Time Benefits (Moon Gravity)

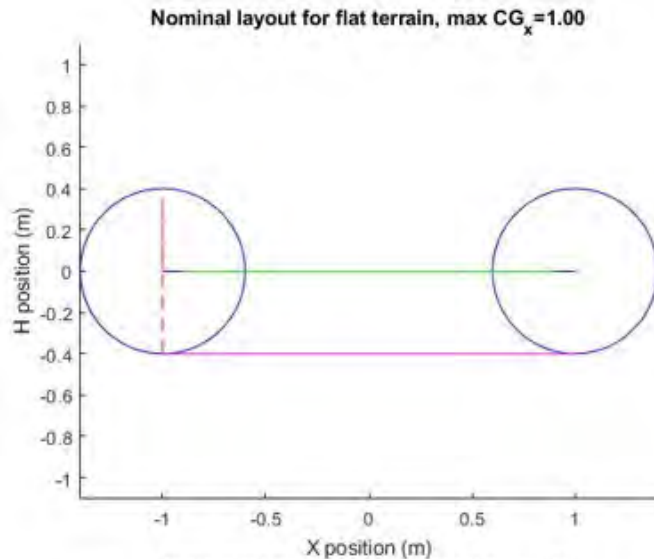

Back wheel angle: 0.0, Front wheel angle: 0.0

Layout for high-stability on smooth terrain, max $CG_x = 0.97$

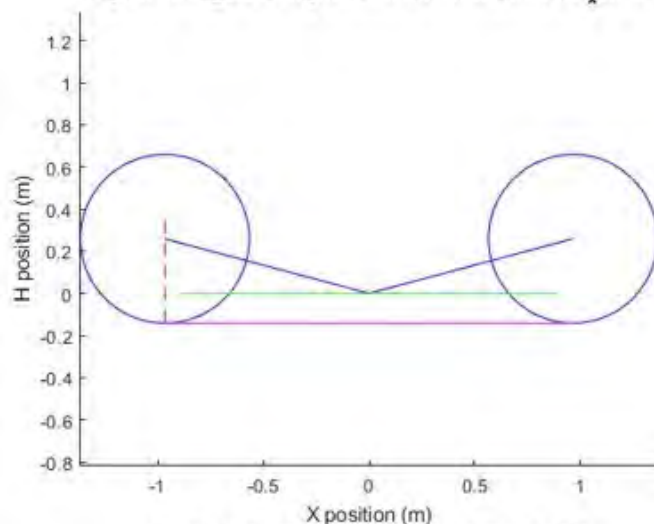

Back wheel angle: 15.0, Front wheel angle: 15.0

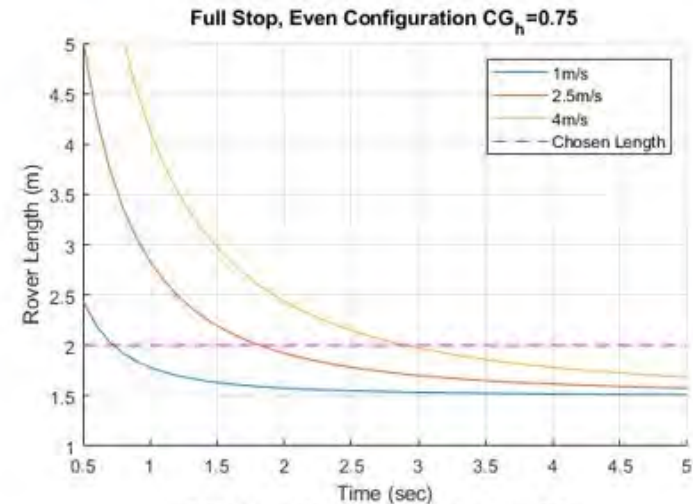

2.00 m rover length: 1.0 m/s stop time: 0.8 s

2.5 m/s stop time: 1.9 s

4.0 m/s stop time: 3.0 s

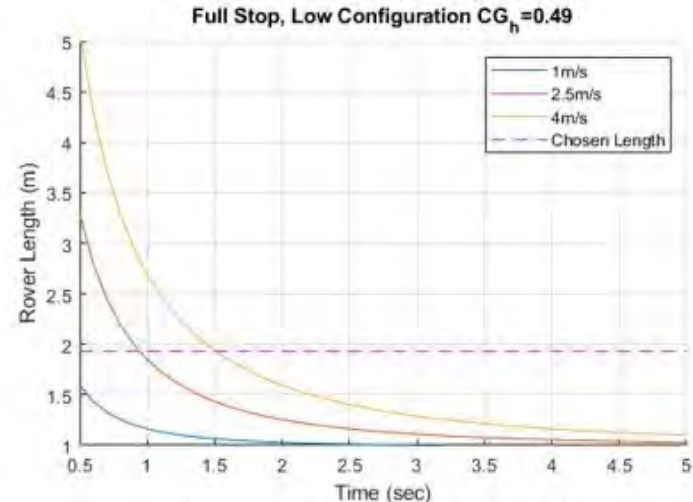

1.93 m rover length: 1.0 m/s stop time: 0.4 s

2.5 m/s stop time: 1.0 s

4.0 m/s stop time: 1.6 s

Decisions Made Heading into Detail Design

- Maximize utility by maximizing maneuverability
 - Articulated wheel linkages
 - Keep body frame level on slopes
 - Increase stability
 - Can lower for ease of ingress/egress
 - Can serve as a versatile positioning platform for mounted robotics
 - Accommodate 25° slopes (all directions)
 - Active wheel steering
- Make the rover as comfortable as possible for crew
 - Suspension system to ameliorate terrain impacts
 - Ease of ingress/egress

VERTEX* Full Assembly



***Vehicle for Extraterrestrial Research, Transportation, and EXploration**

UNIVERSITY OF
MARYLAND

Earth Analogue Goals

- Wheel-turn steering
 - Avoid SSL historic gravitation towards skid-steer platforms
 - Minimum front OR rear wheel steering mechanism
 - NASA's favorite – crab drive!
- Transportability
 - Footprint should be collapsible within a standard footprint
 - Inner box-truck dimensions size 5'x8', and became storage footprint requirement for rover
 - CLPS lander configuration likely falls within this area with spacecraft such as Griffin

Rover Platform

- Chassis requirements:
 - Provide dedicated structure space for all components such as batteries, cargo, suspension, and astronauts
 - Batteries must be separated but nearby each other for safety and thermal requirements
 - Consider wheel turning volume exclusion requirements
 - Astronaut containment ideally including boot protections, roll cage, and life-support pack considerations
 - Unobstructed entry and exit from driver's position
 - Support rollover, impacts, and obstacle climbing loads
 - Field repairable

Rover Platform

- 4130 Chrome Moly
 - Majority 1"x1"x0.049" square tube construction
 - MIG weld assembly
 - Ladder design
 - Octagonal steering considerations
 - Five compartment separation

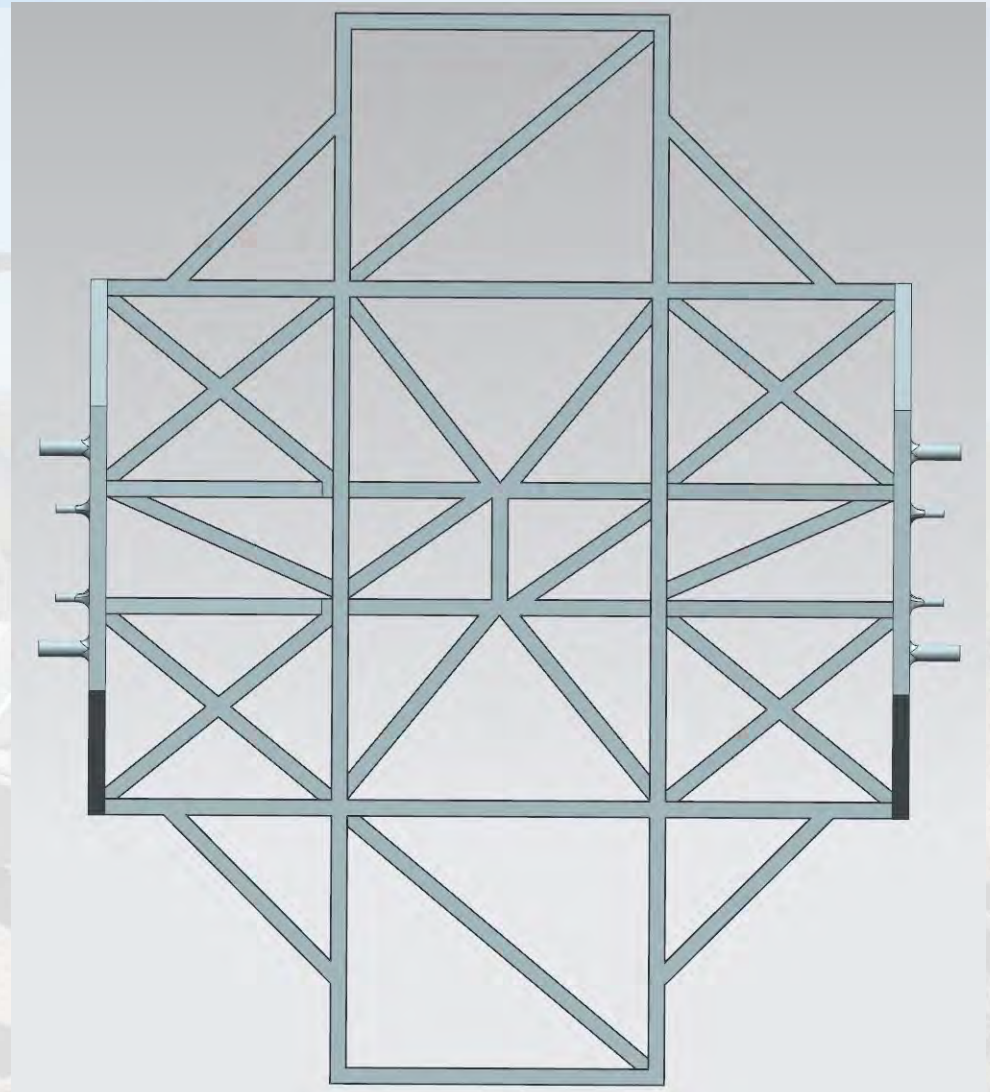

Rover Platform

- Rotation axis mounting points for wheel arm (tapered roller bearing)
- Vertical struts
 - Linear actuator mounting points
 - Spring and shock absorber mounting
 - Base for roll cage mounting

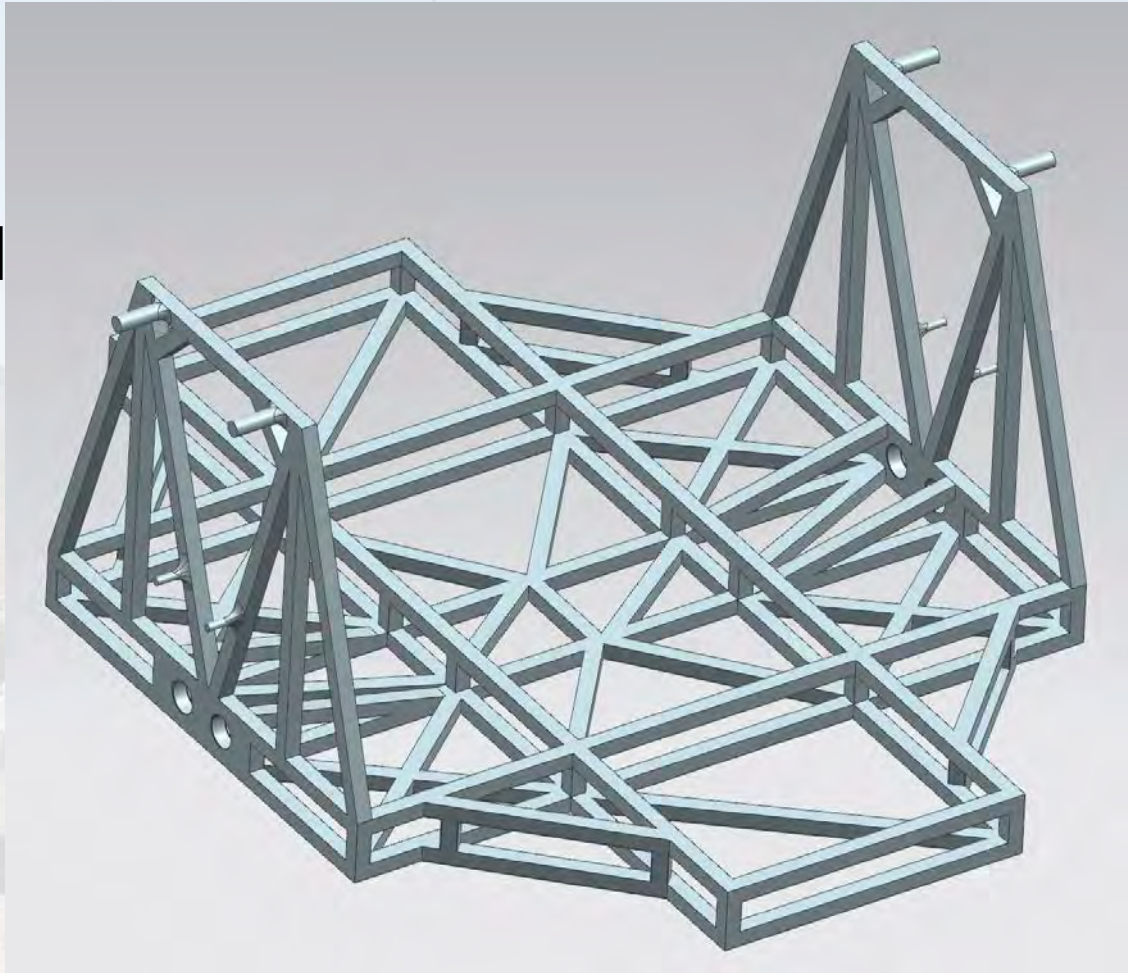

Rover Platform

- First mode of bending: 12.875Hz
- Base frame first mode was ~65Hz
- Removable roll cage integration to chassis being designed for rollover and stiffening
- FEA of 5G front impact, high load bending/torsion

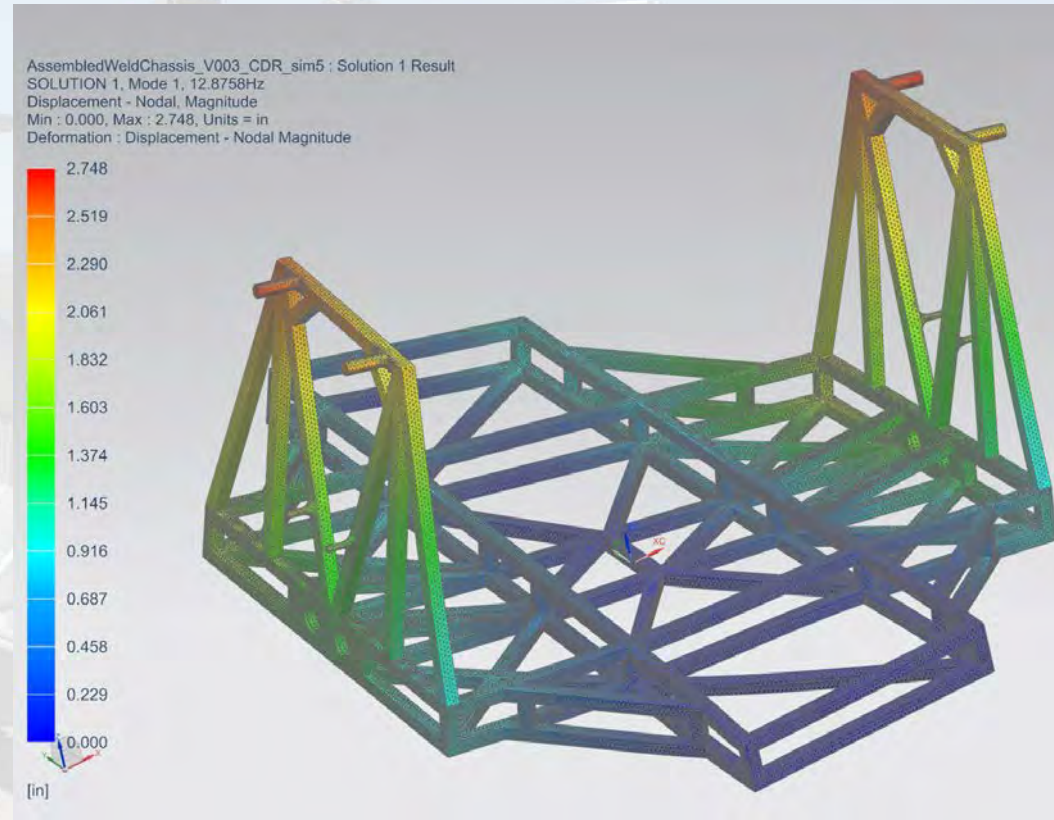

Wheel Selection

- Commercial pneumatic tire with non-aggressive tread pattern to conserve testing location soil
- Goal: 32" (dia) x 8" (wide)
- Expected: 31.7"x8.49"
 - LT215/85R16 General Grabber APT
 - 16x6.5 5-100 50mm offset stamped steel rim (not pictured)
 - 50mm offset aids in motor/gearbox containment

Drive Requirements

- Wheel Torque
 - 200 Nm continuous for 4m/s travel @ 0° slope
- Drive requirements mean that ~2.5 kW per wheel is needed
- Most DC motors could not produce 2.5kW continuously while allowing for 4m/s top speed
- AC motors considered, but decided against due to the added mass and volume of an inverter unit
- Hydraulic motors considered

Motor Selection

Magmotor BFA42-2E-300

- Dynamic brake, 97.6 Nm holding force
- 500 count encoder
- Thermal switch to prevent overheating
- 6 Nm continuous torque @ 3100 rpm
- 200 Nm @ 93 rpm after a 33:1 gear reduction

Gearbox Trade Study

- Getting >200Nm at the wheel is difficult with 90 rpm top speed goal
 - Harmonic drive output has high torque, but cannot handle high enough rpm
 - Most planetary gearboxes were either >\$5k and >50lb each
- Trade study for seeing if a spur gear speed increaser applied to a harmonic drive gear reduction was viable
- 50:1 followed by 1:1.5 (33:1 total) ideal for motor

Harmonic GR	Speed Increase	Total GR	Cont T	Cont RPM
120	1.5	80	2.5	7360
160	2	80	2.5	7360
80	1	80	2.5	7360
100	1.5	67	3.0	6133
120	2	60	3.3	5520
80	1.5	53	3.8	4907
100	2	50	4.0	4600
50	1	50	4.0	4600
80	2	40	5.0	3680
50	1.5	33	6.0	3067
50	2	25	8.0	2300
50	2.5	20	10.0	1840
50	3	17	12.0	1533

Gearbox Selection

Harmonic Drive LLC HPG-32A-33 planetary gearbox

- 33:1 gear reduction
- 330 Nm peak torque limit

Wheel-Motor Stack Diagram

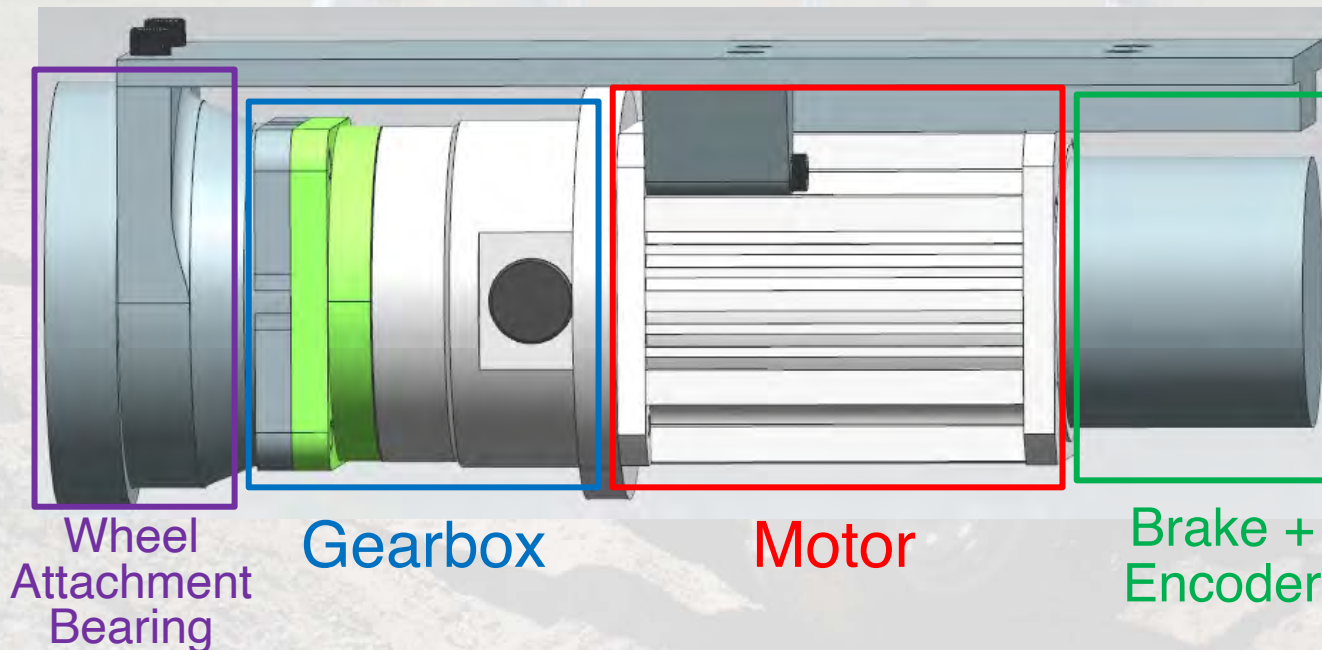

4-Bar Linkage Study

Linkage configuration designed in Matlab to minimize caster angle at all slopes

- Reduces steering torque
- Stiffens the wheel connection in bending

Downsides

- Very bulky
- Vertical bars connecting to wheels reach 1.25m off the ground...

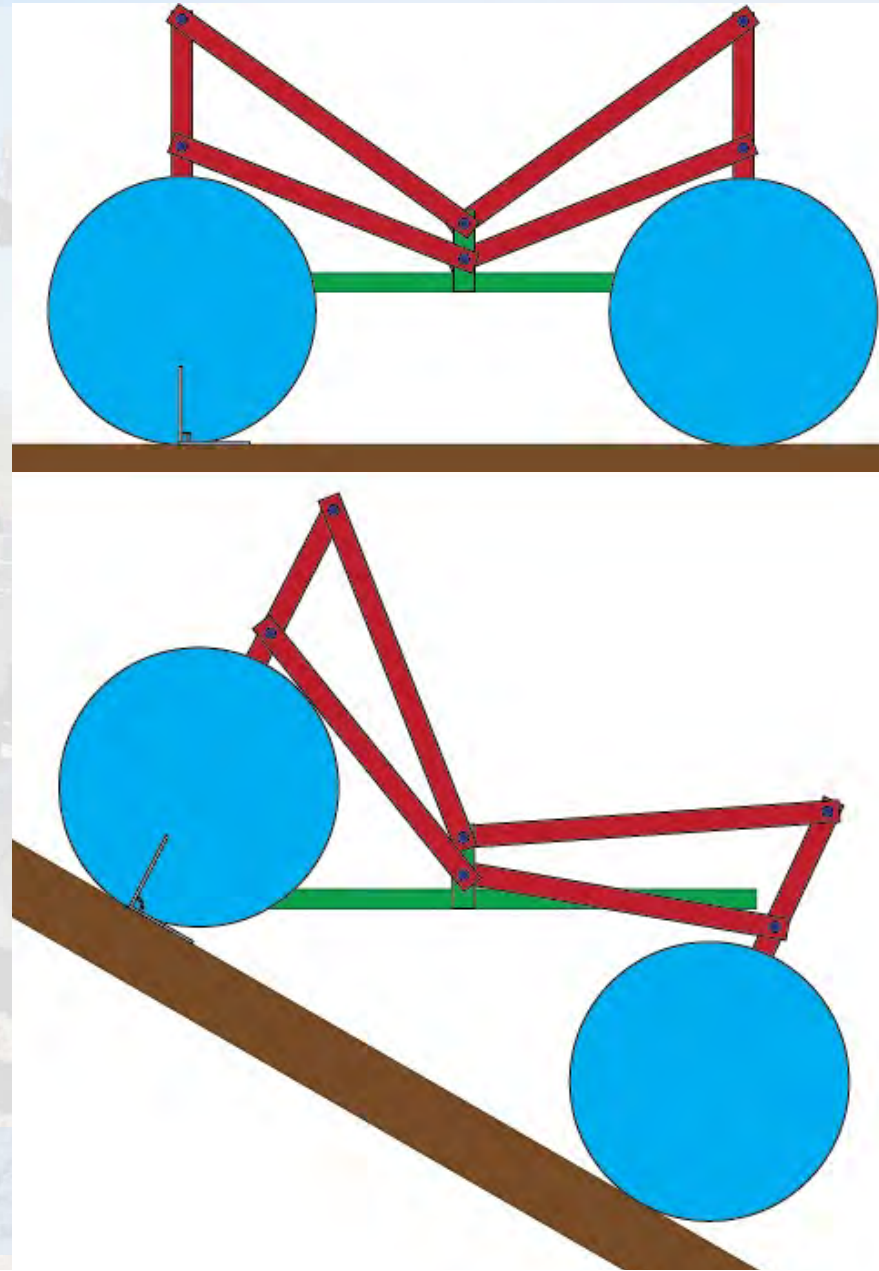

Potential For Caster Angle Study

- Accounting for caster angle increases with a larger steering motor gearbox
- Wheel-link connection retrofitted with a variable-angle plate
 - Allows caster angle to be changed between tests
 - Ability to test camber angle effects while crab driving

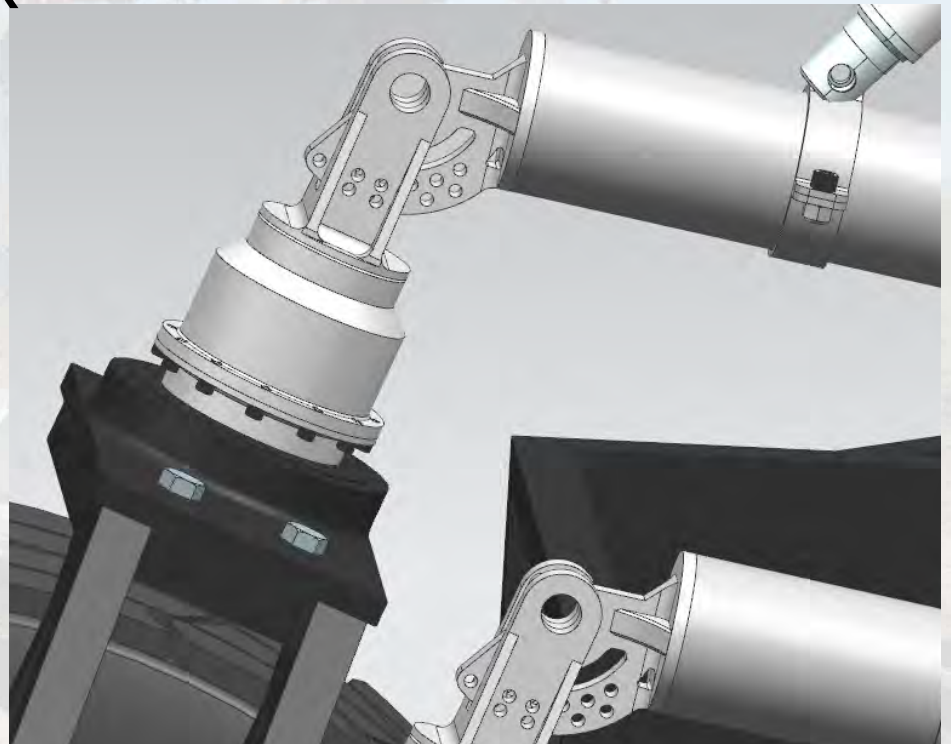

Steering Actuator

- Brushless DC/Harmonic Drive pairing from RANGER
- Kollmorgen RBE-02112-A15
- Harmonic Drive HDC-032-060-2AK2 SP
- ~102 ft-lbs torque @ 3.2 rpm
- Final Encoders not specified yet, but likely similar to RANGER's heritage design

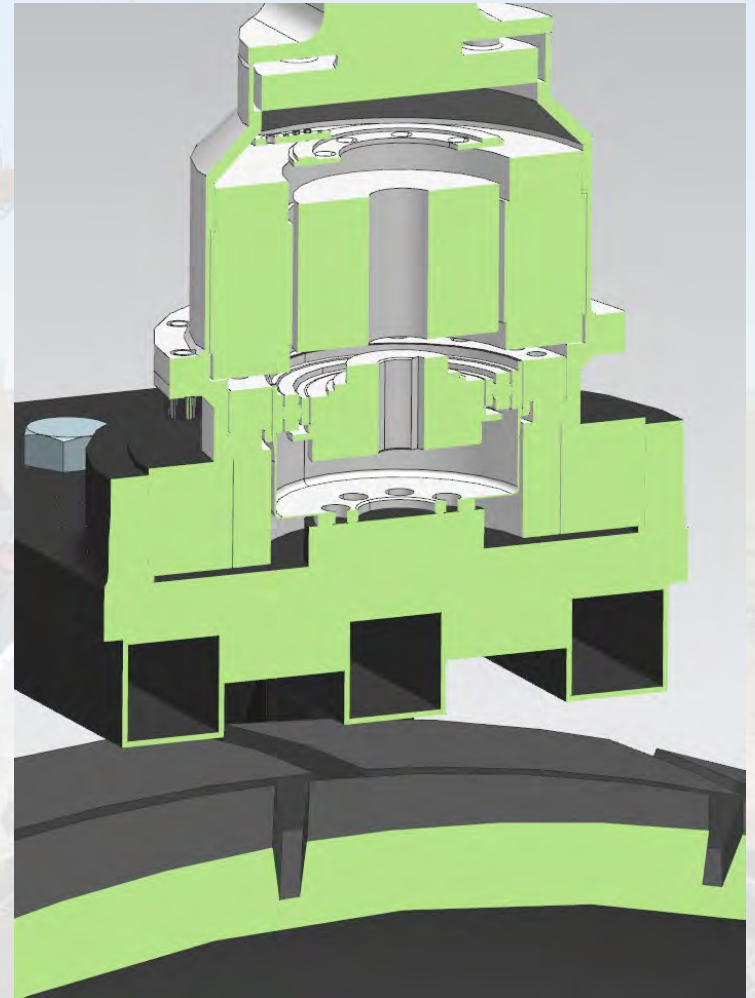

Linear Actuator Placement Study

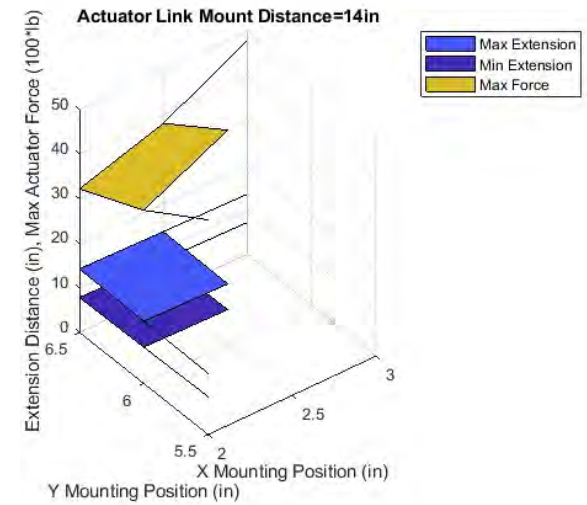
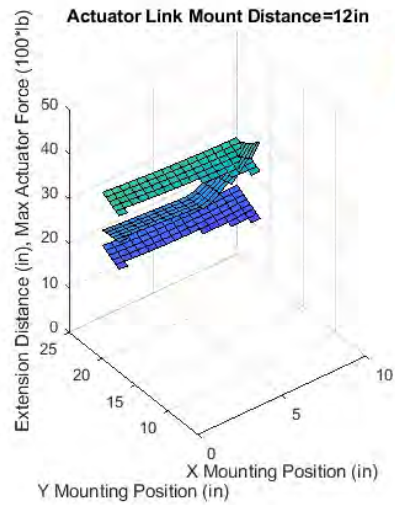
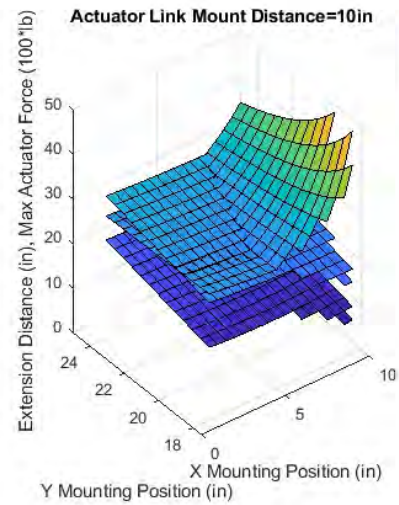
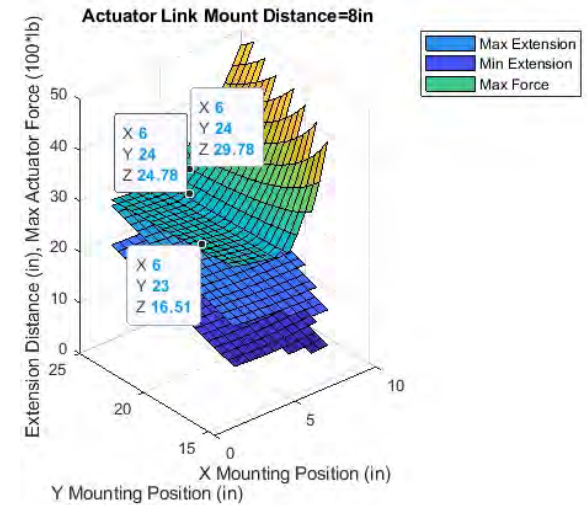
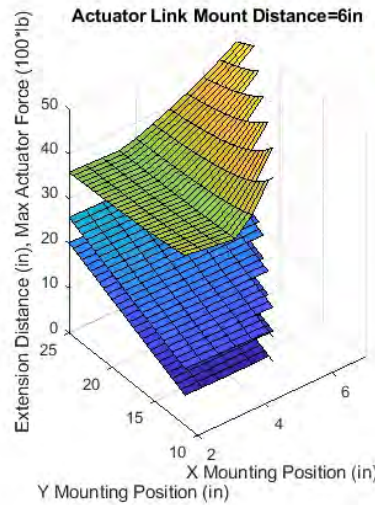
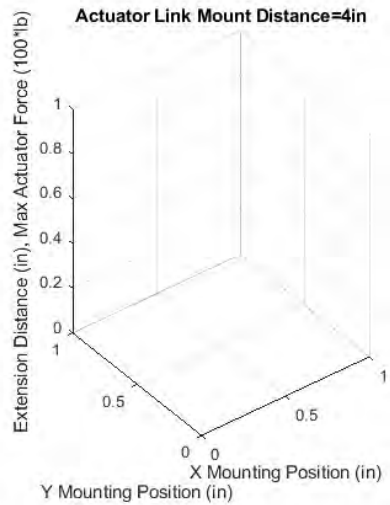

Linear Actuator Placement

- Study used to specify actuator requirements
 - 3000 lb force
 - 25” extension length
 - 16” retracted length
- Chosen PA-13 actuator also has:
 - 3500 lb holding force when power is shut-off
 - Hall effect sensor for position data

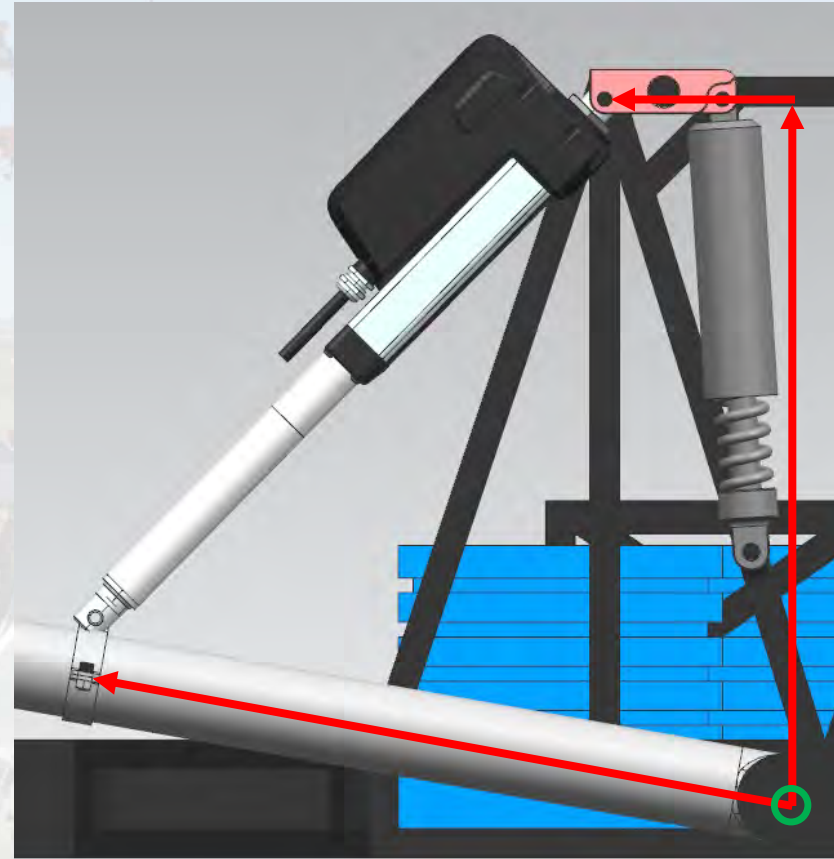

**Chassis mount positioning,
wheel link connection point**

Suspension

- Fully adjustable shock absorber with retained coil spring
- Motion translated in-plane via pivot
 - Pivoting bar (red) represents only a motion prototype
 - Final version will translate force more efficiently and utilize full travel capacity
- Tunable series elastic actuator

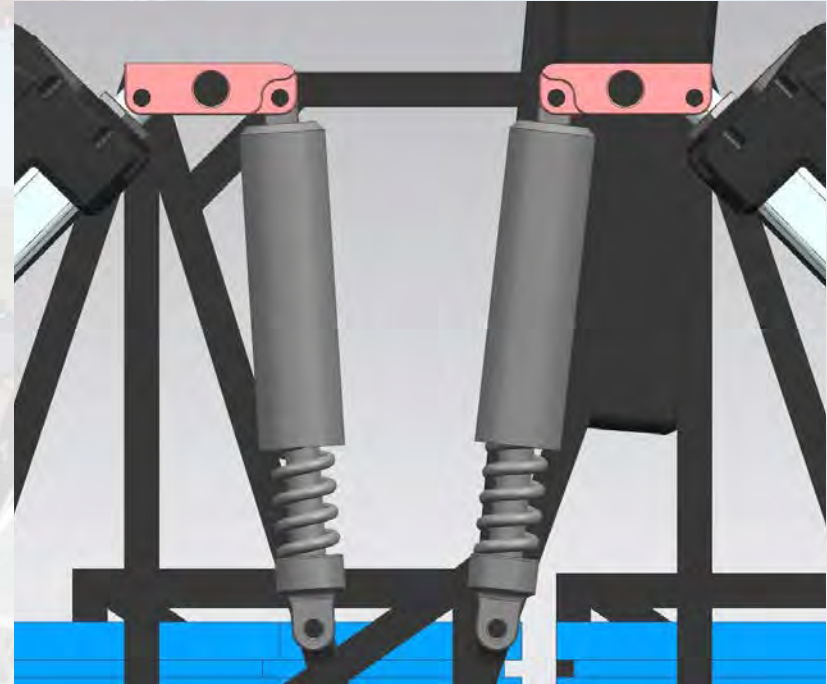

Suspension

- Mass/spring/damper system still under tuning as mass budget and linear actuator study form
- Parameters
 - Allowable travel - 5"
 - Spring constant – 2400 N/m
 - Damping ratio – 0.9969
 - Osc. Freq – 0.05 Hz
- Damping and spring values adjustable in the field



VERTEX Sample Roll Cage



VERTEX Up/Down Slopes



VERTEX Cross Slopes

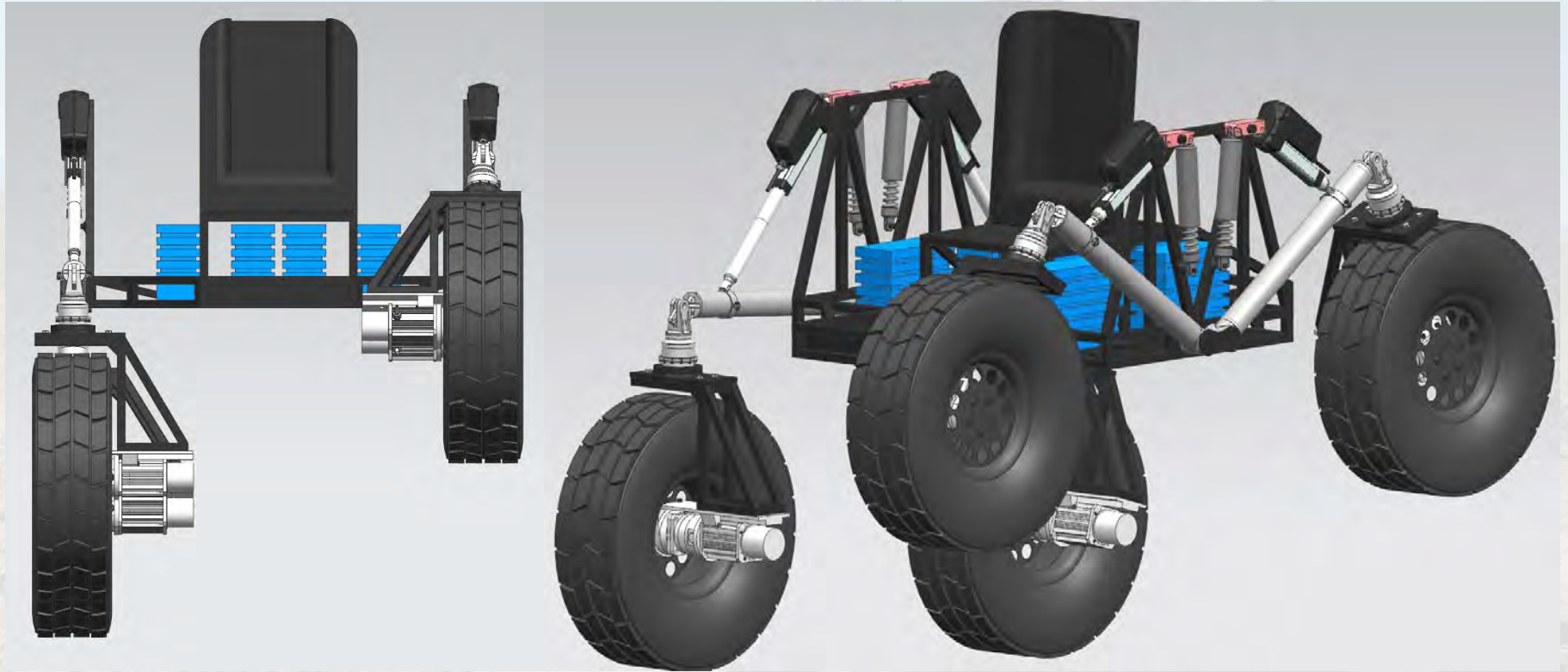

VERTEX Ingress/Egress Low

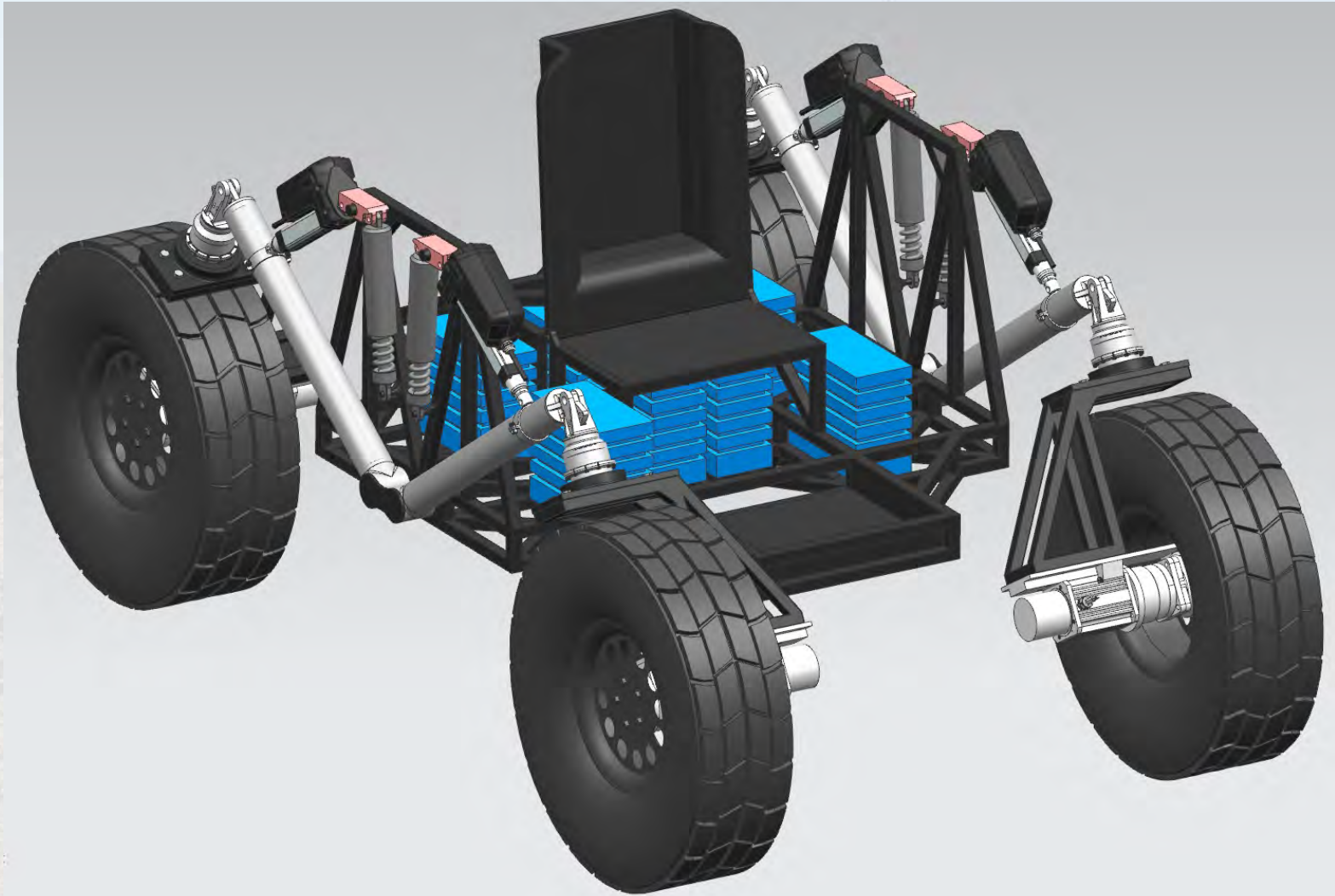

VERTEX Ingress/Egress Kneel



A Folded Configuration

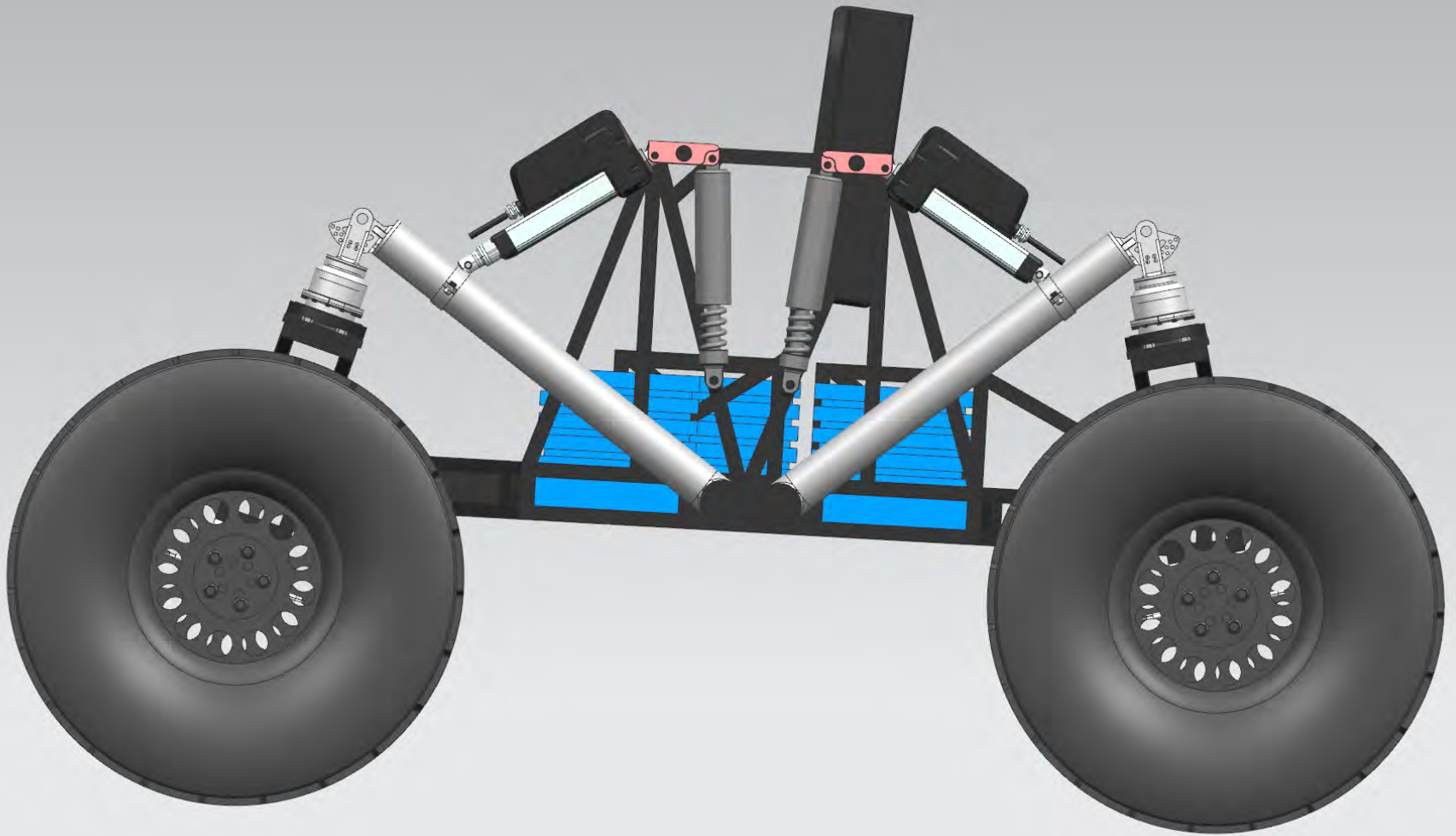

Slightly Unfolded

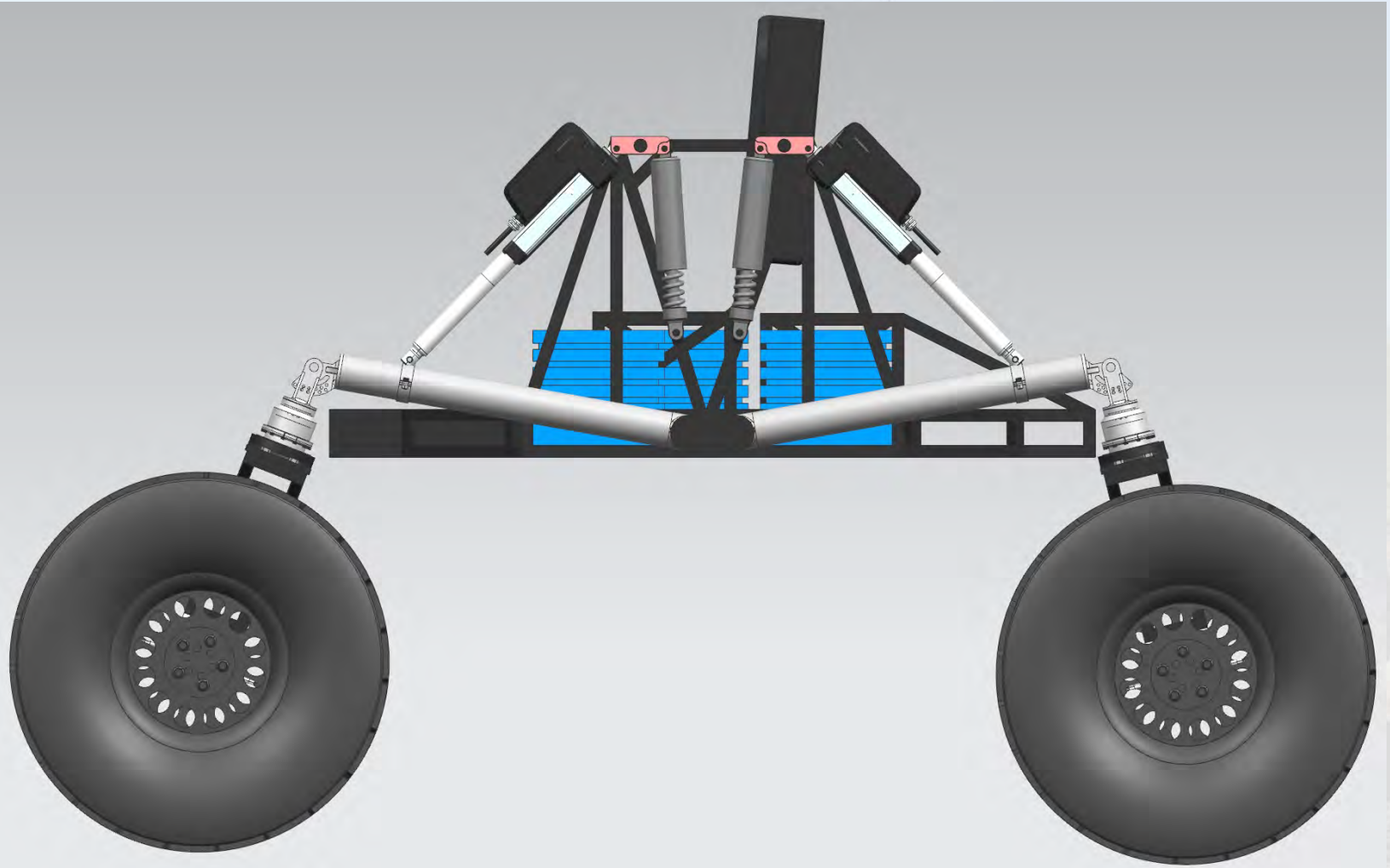

Slightly Unfolded



Front Wheel Steer (Ackermann)

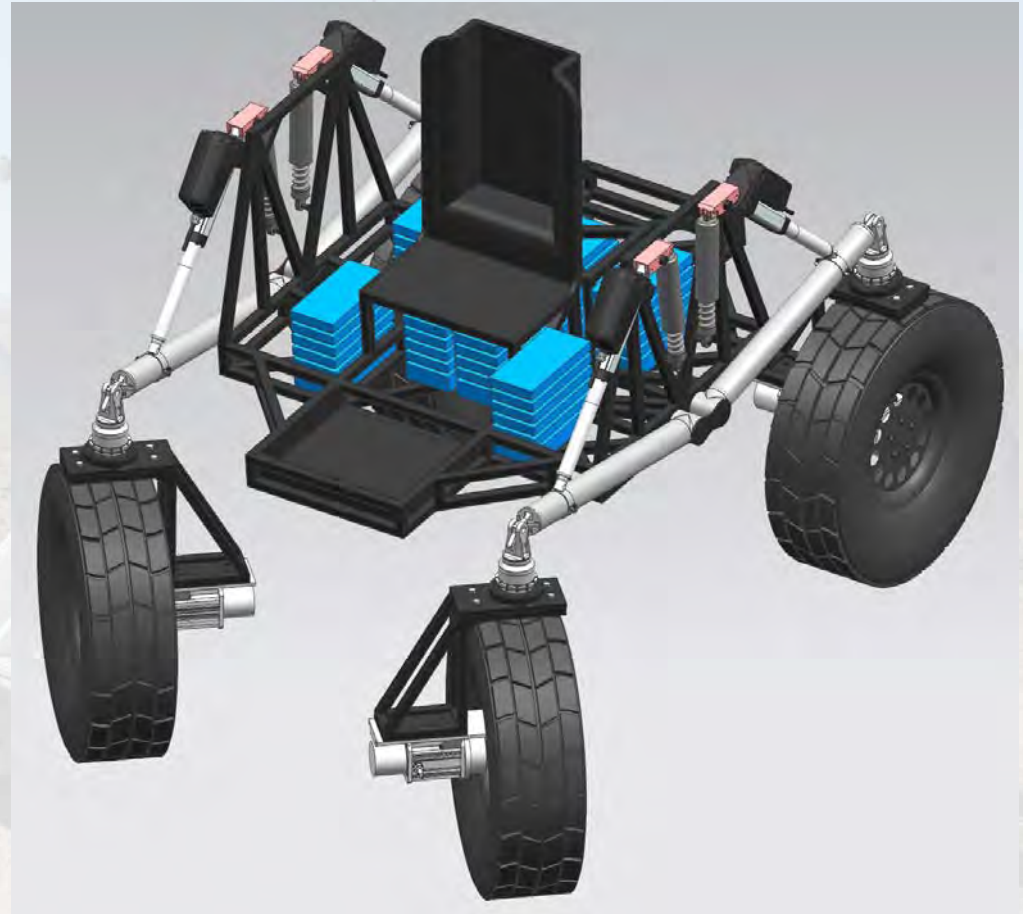
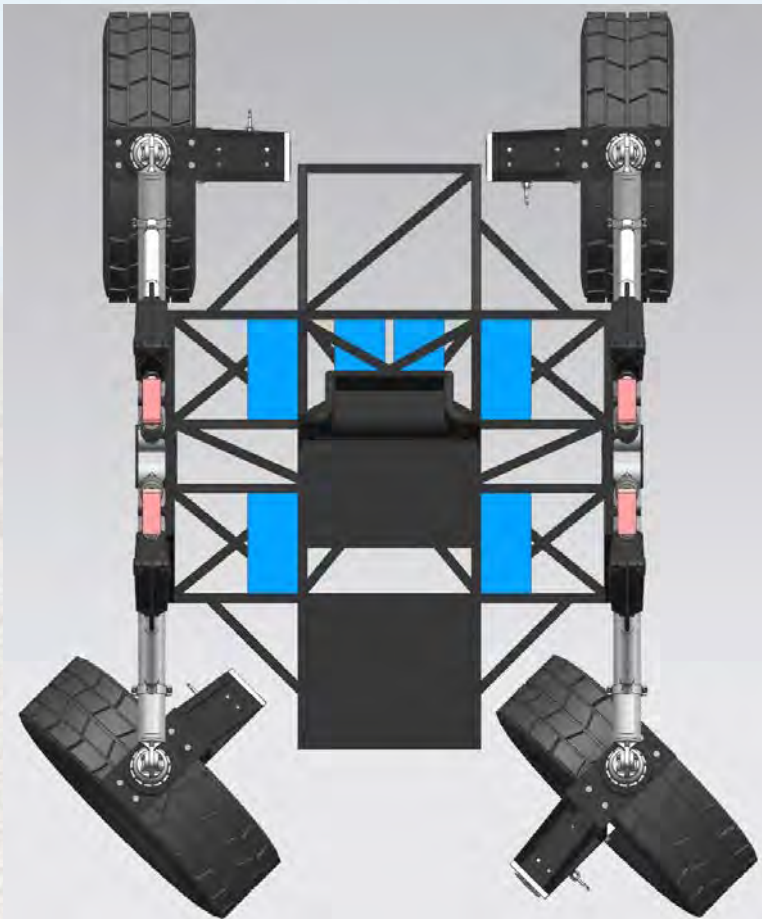

45° Translation

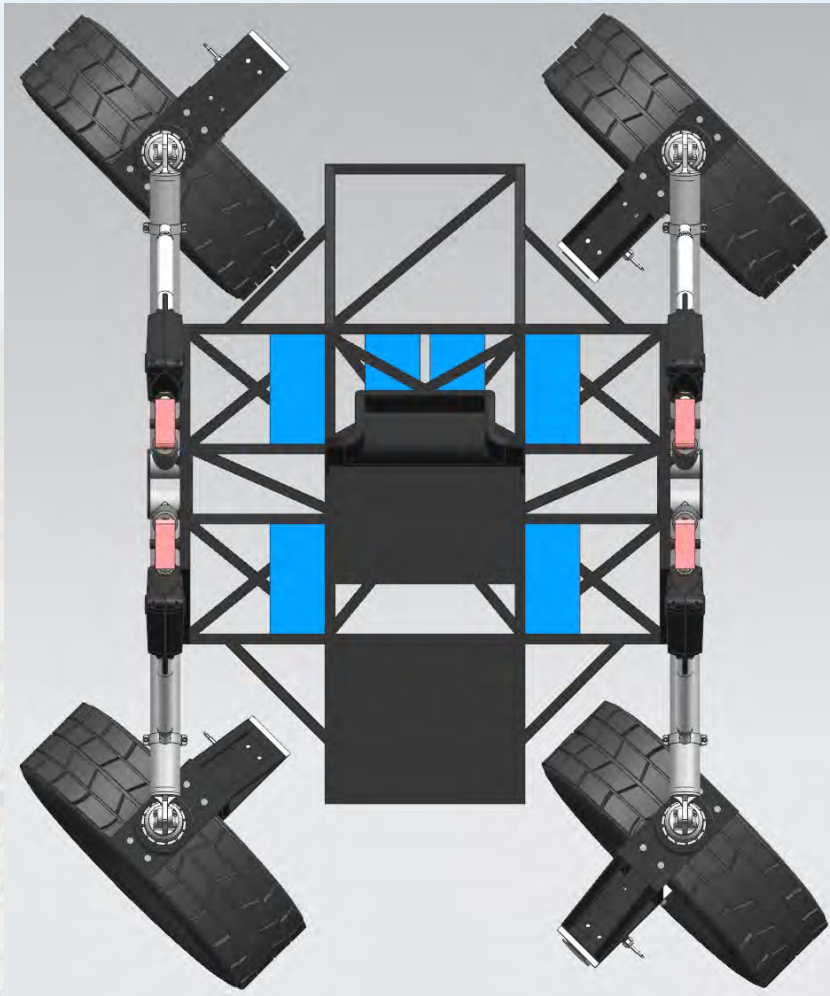

Sideways Crab Drive

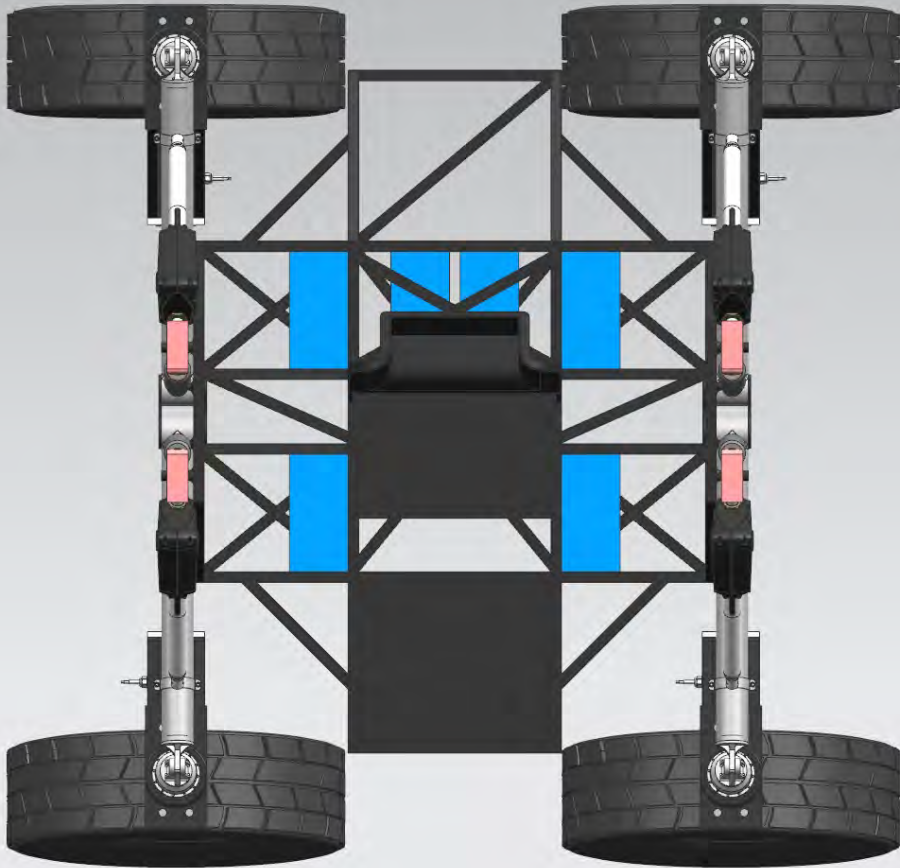

Turn in Place

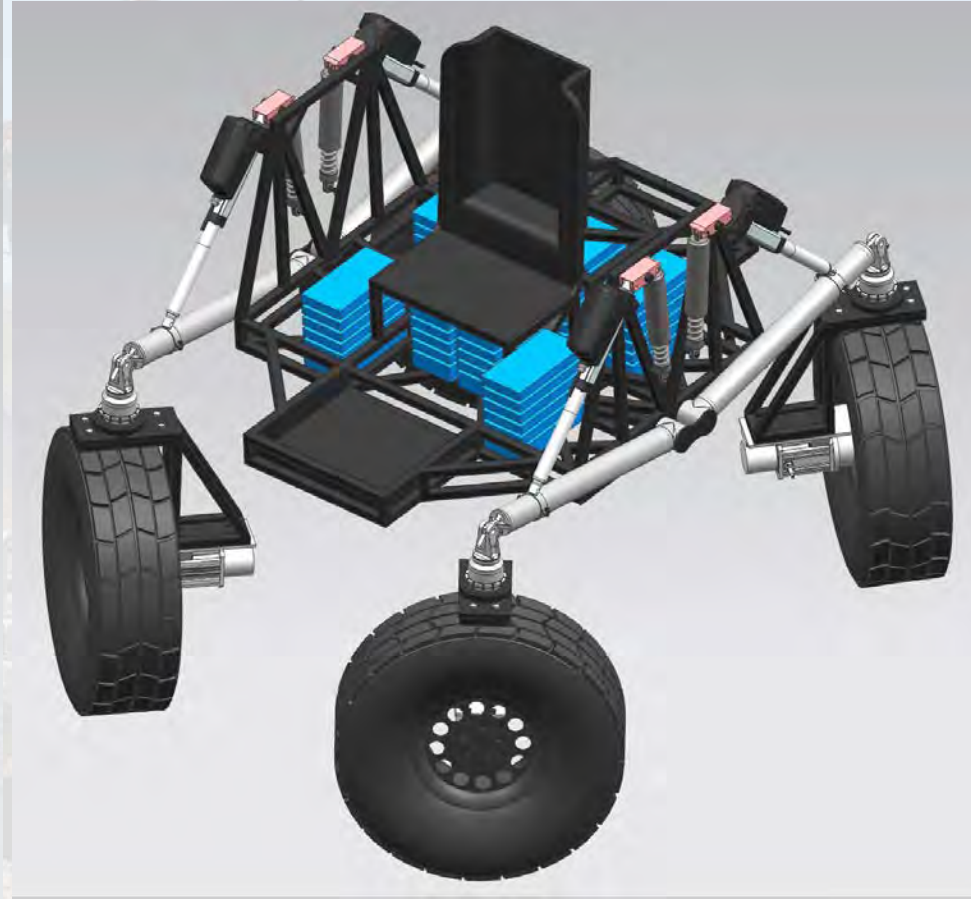
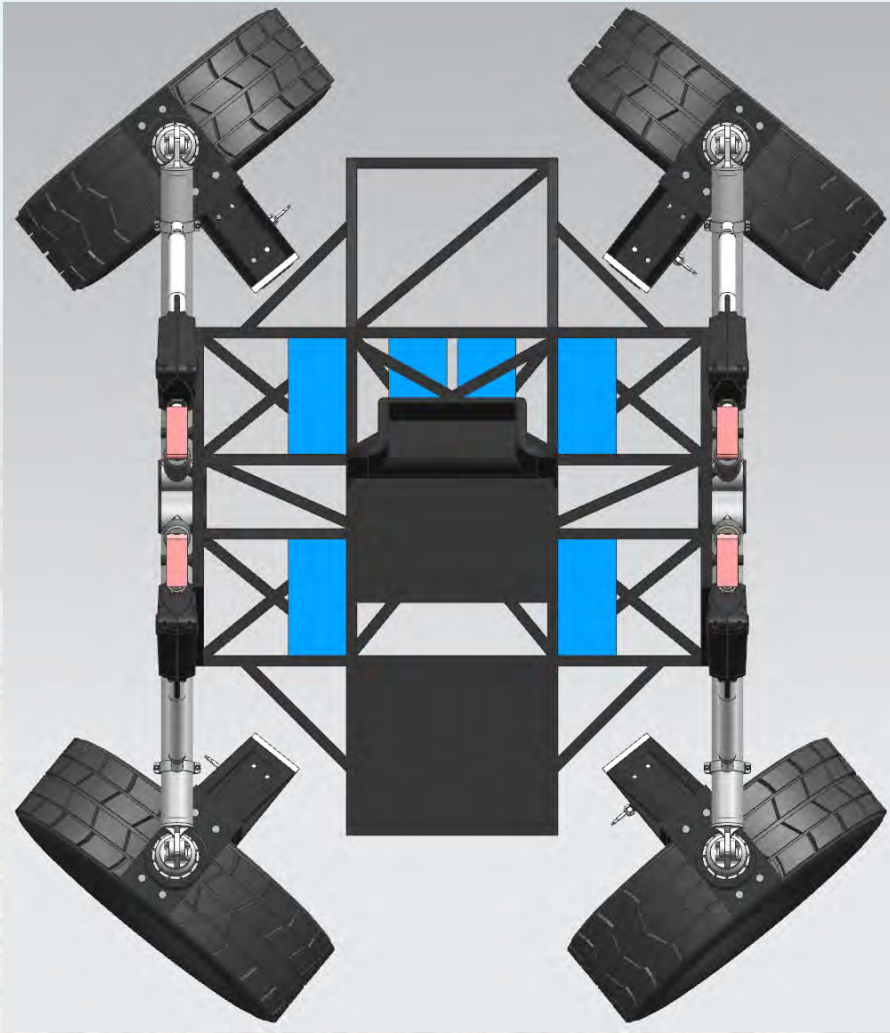

Up-Slope Climb

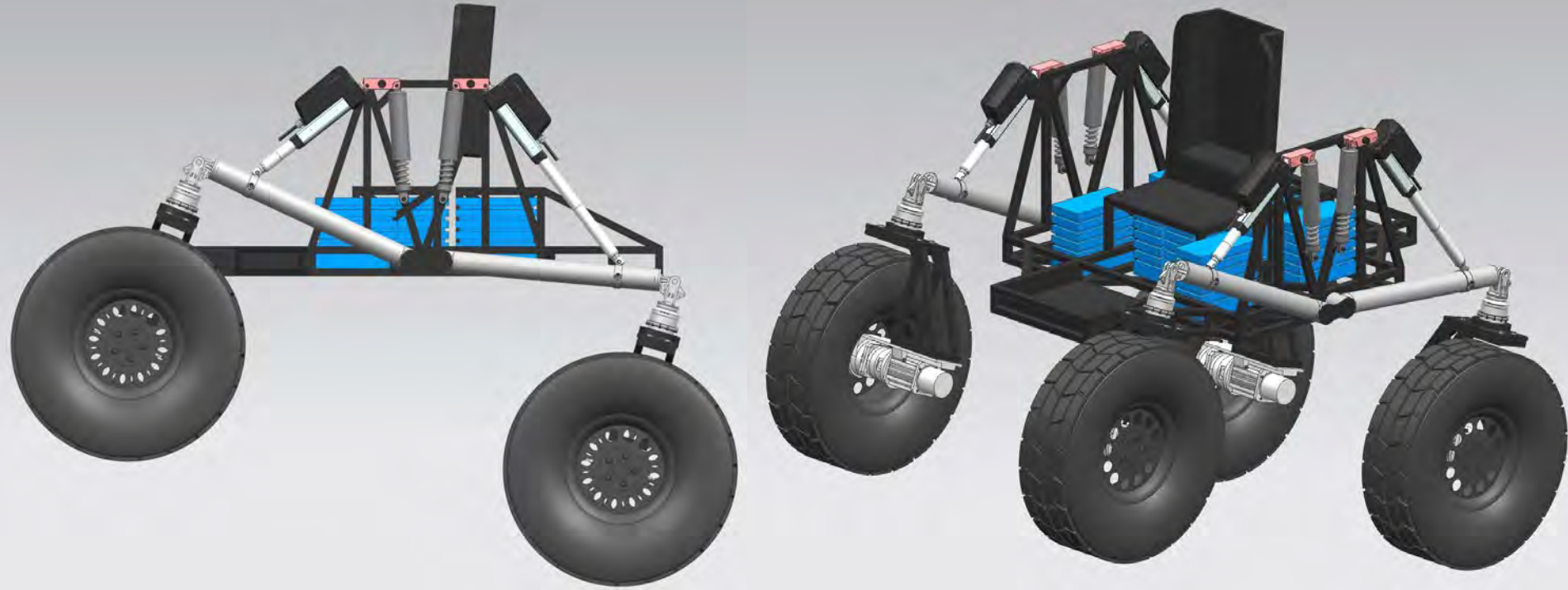

Up-Slope Climb (Max 30°)

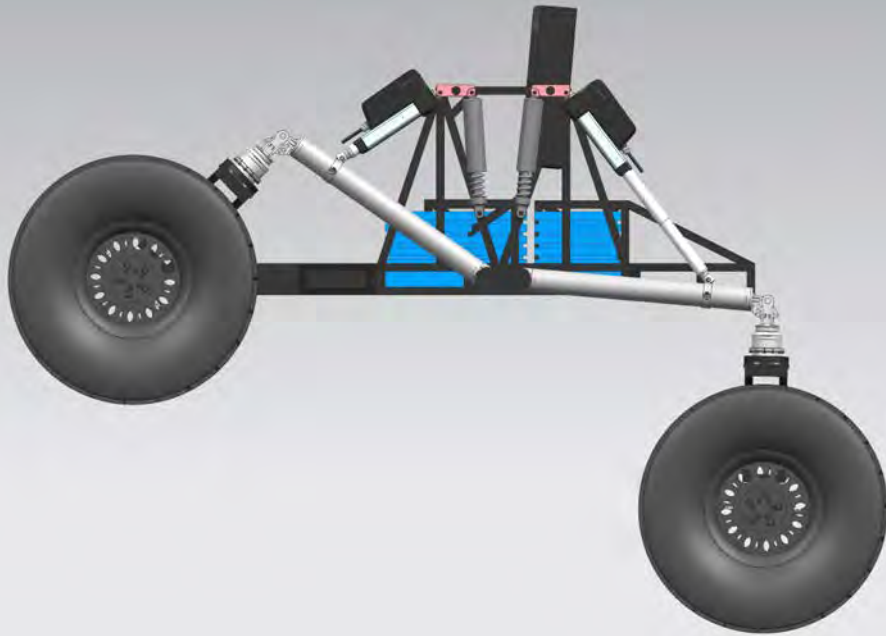

Low Caster Angle

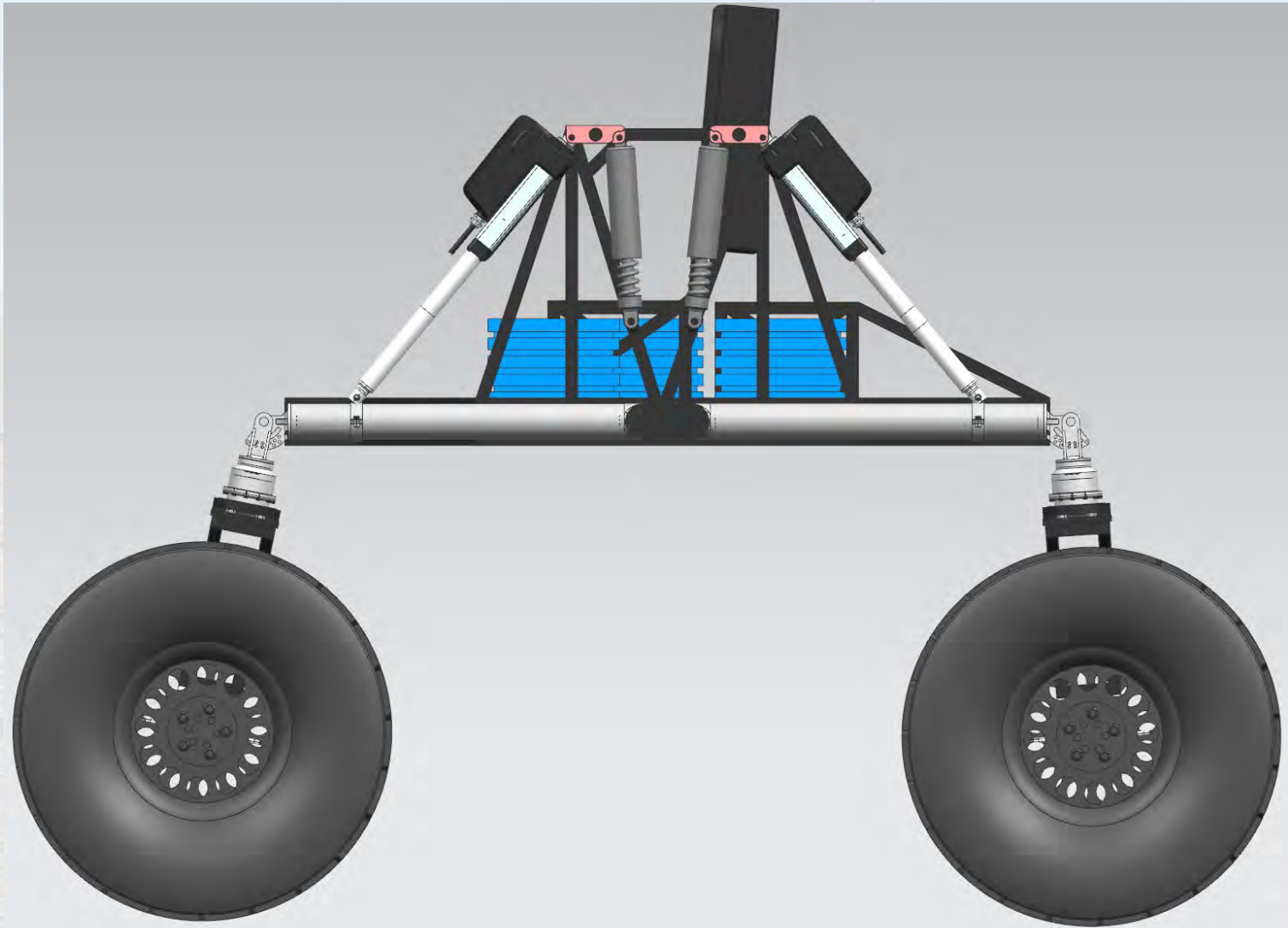

Negative Caster Angle

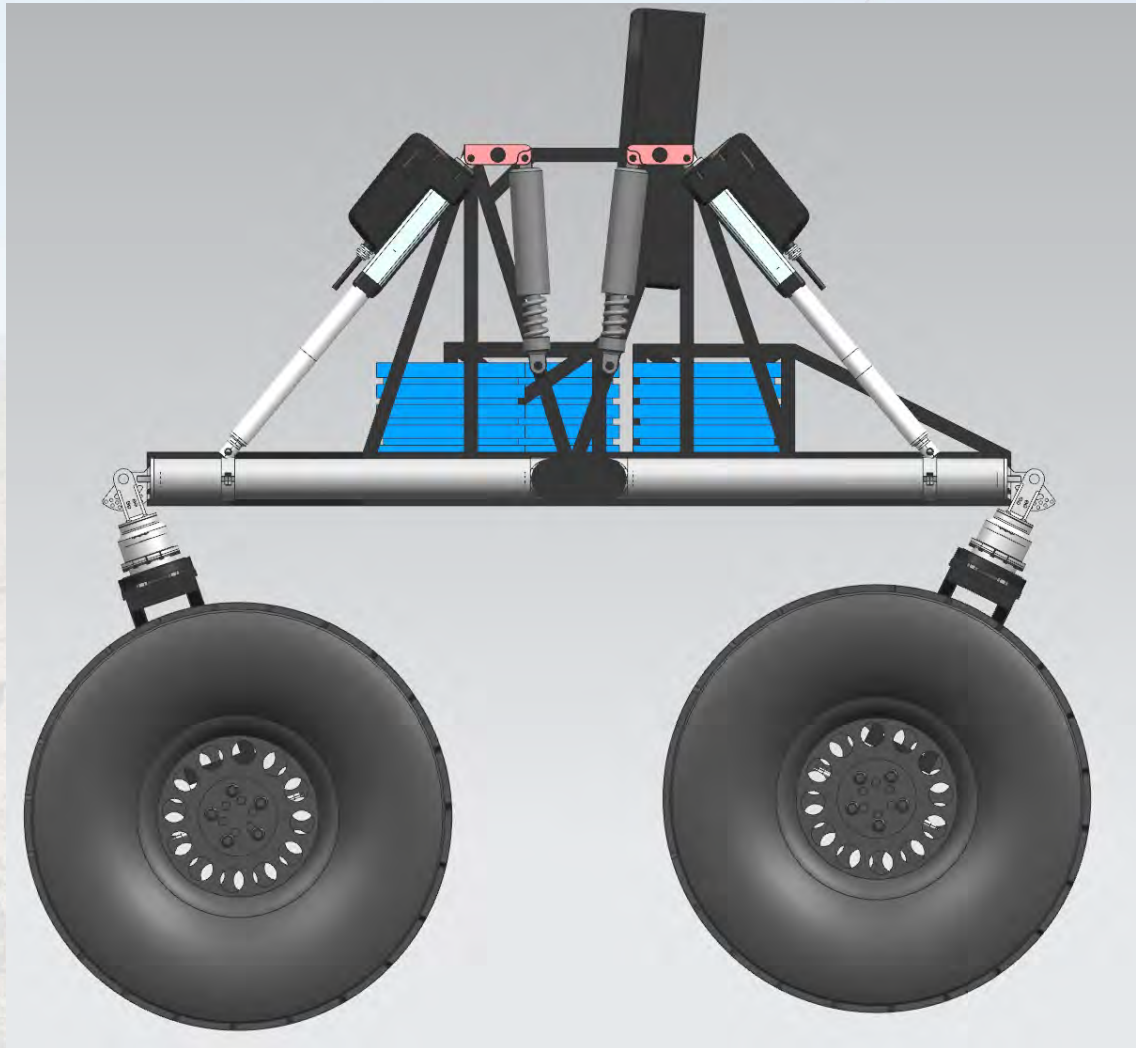

Positive Caster Angle

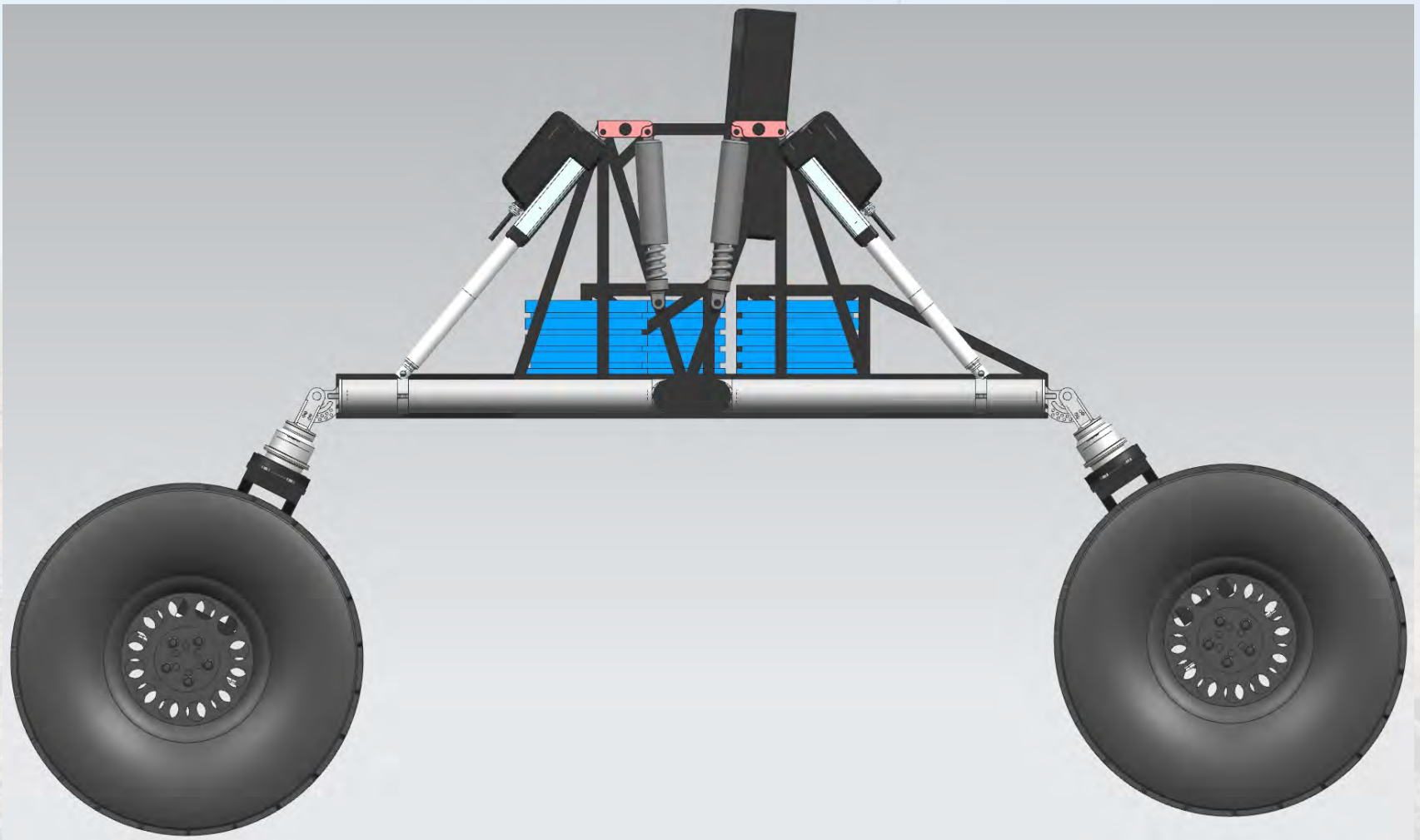

Possible Stowed/Launch Configuration

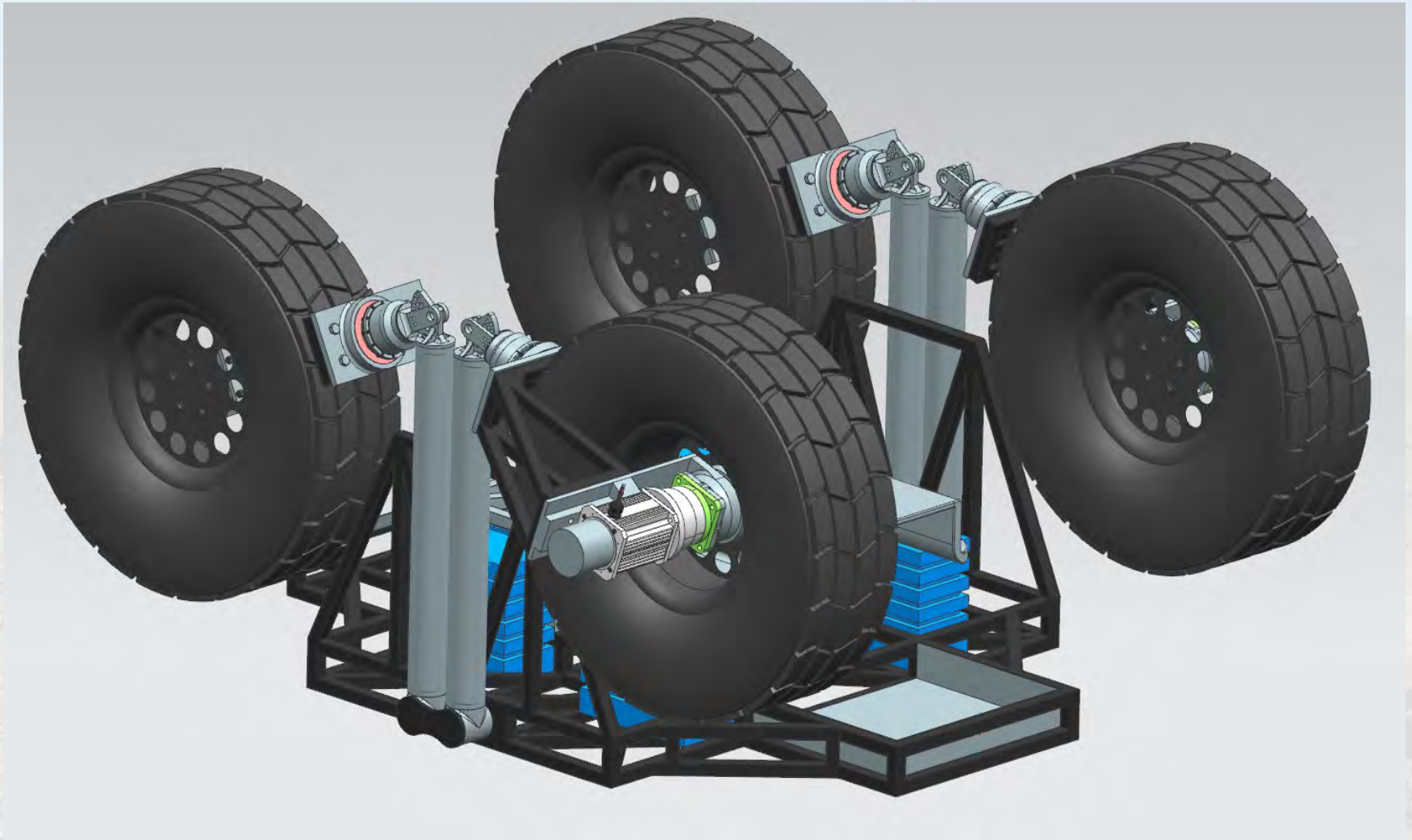

Spring 2021 Activities

- Finalize system and subsystem designs
 - Heavily reference 788X design work
 - Complete mechanism design
- Mechanical and electrical build and test
 - Machining mechanical components
 - Vehicle integration and testing
- Implement human-driven, teleoperated, and autonomous control software
- Conduct human-driven and autonomous operations testing
 - Human factors of astronaut users (COVID restrictions permitting)
 - Autonomous navigation and exploration
 - Analog field testing

Electrical System Design Logic

- VERTEX operates at power/energy levels comparable to modern electric vehicles (EVs)
- Using existing mass-market EV parts would reduce development time, cost, and improve reliability and safety
- Core system was thus designed to resemble an EV system, to maximize utilization of COTS parts
- High-voltage charging/shore power interface was specifically chosen to be compatible with modern standards, and be portable for field testing

Battery Selection

- Previous rover used a 24V system
- Vertex uses a 96V, 100Ah LiFeMnPO₄ system
 - LiFeMnPO₄ battery chemistry was chosen for power density, and charge/discharge characteristics
 - High voltage was chosen to keep current requirements manageable. Lower voltages require the usage of 00+ gauge cables, which makes chassis routing very difficult
 - 100Ah was found to give a good balance between size, cost and runtime
- Other common chemistries (Lead-Acid) were not selected due to current and weight limits

Battery Charging

- Batteries support 1 hour fast charging at 10kW
 - Onboard charger sized to supply 10kW
- Fast charging possible via a level 2 EV charging station
 - Level 2 chargers available in portable form factors
 - Gasoline generators can provide needed power at remote testing site
- Vehicle also has backup slow charging, possible from a standard 120V, 15A domestic outlet
 - 14-15 hours charge time

Electrical Block Diagram – High Voltage

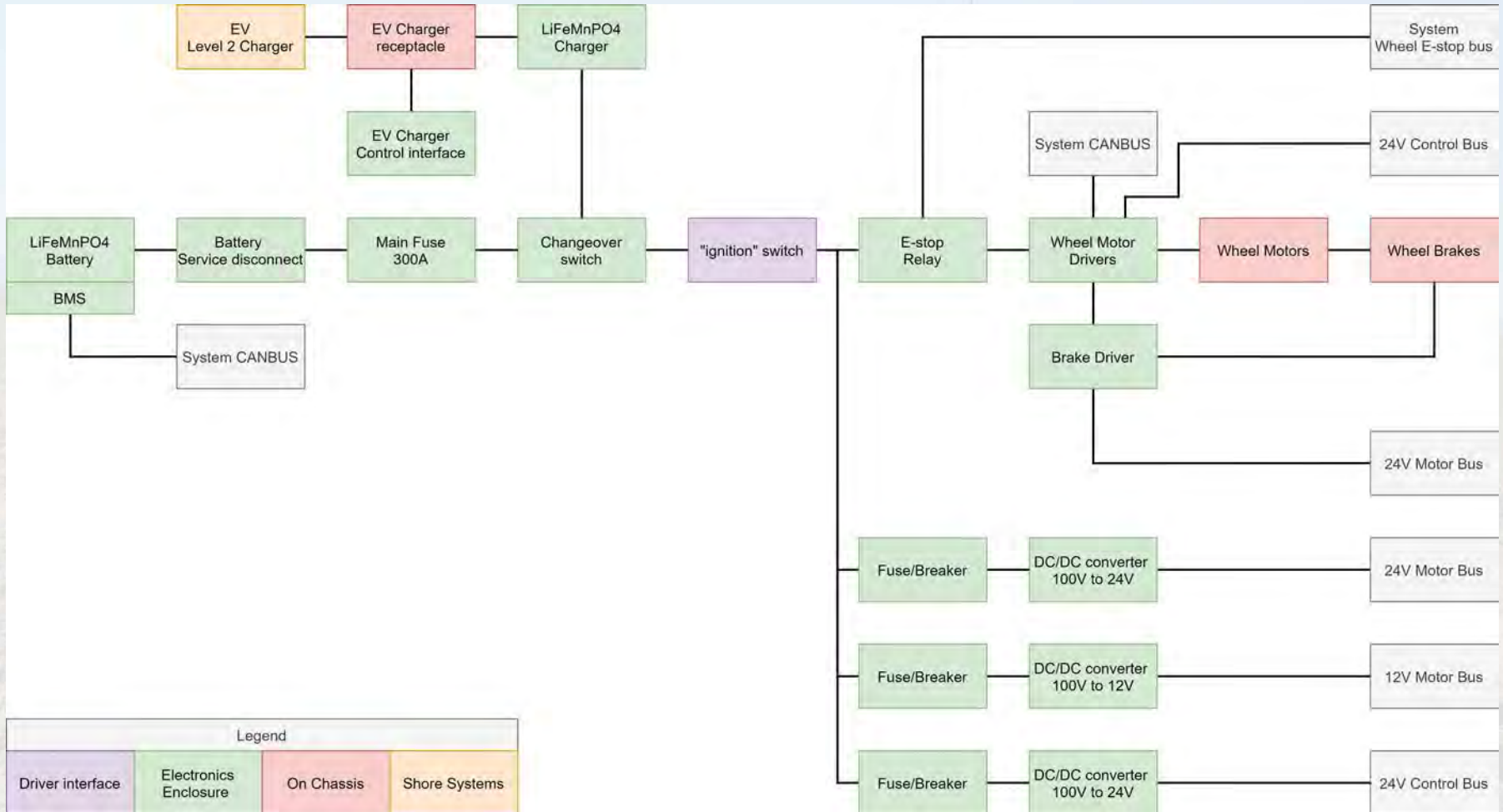

Electrical Block Diagram – Logic System

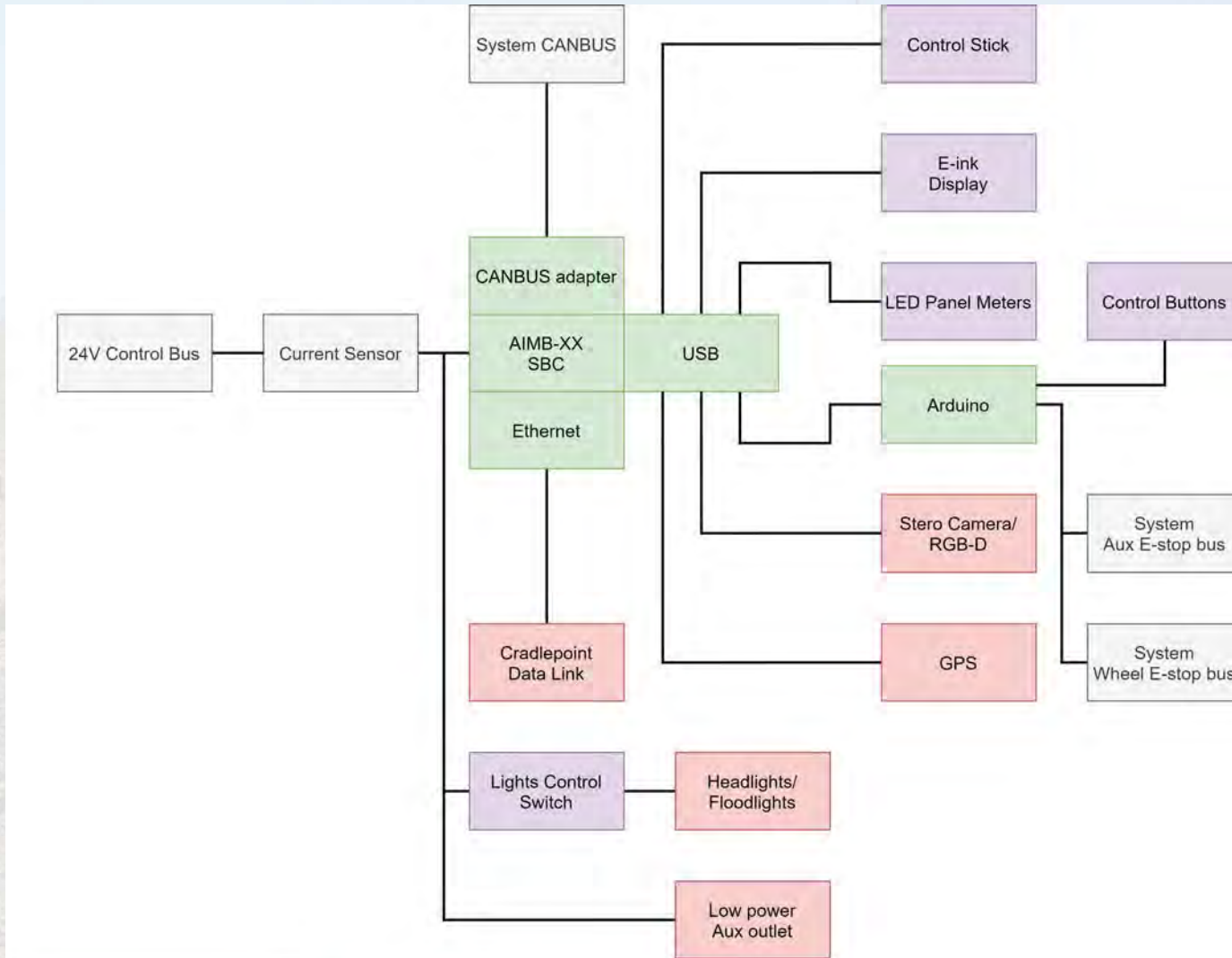

Legend			
Driver interface	Electronics Enclosure	On Chassis	Shore Systems

Electrical Block Diagram - Motors

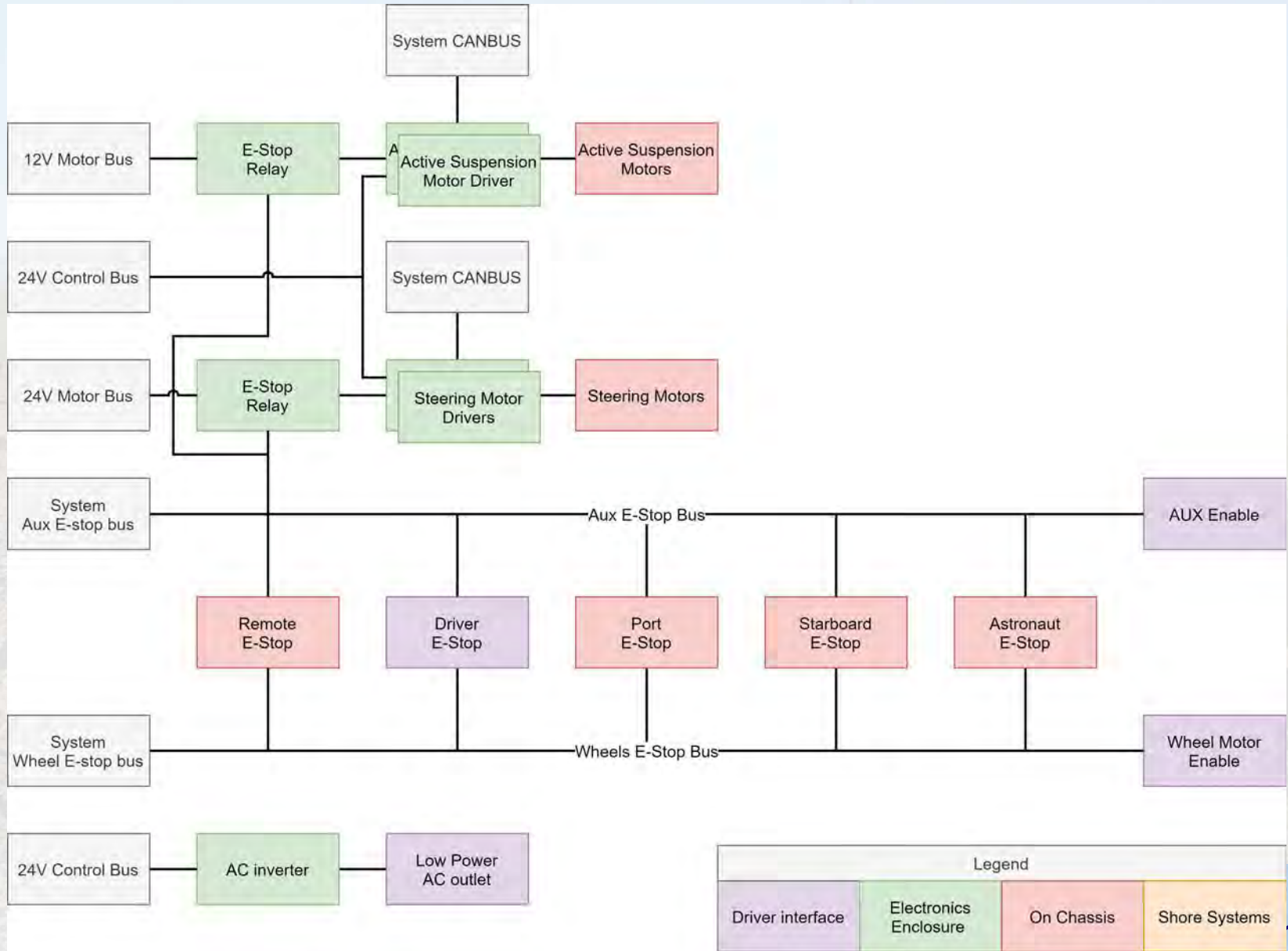

Raven Test Setup

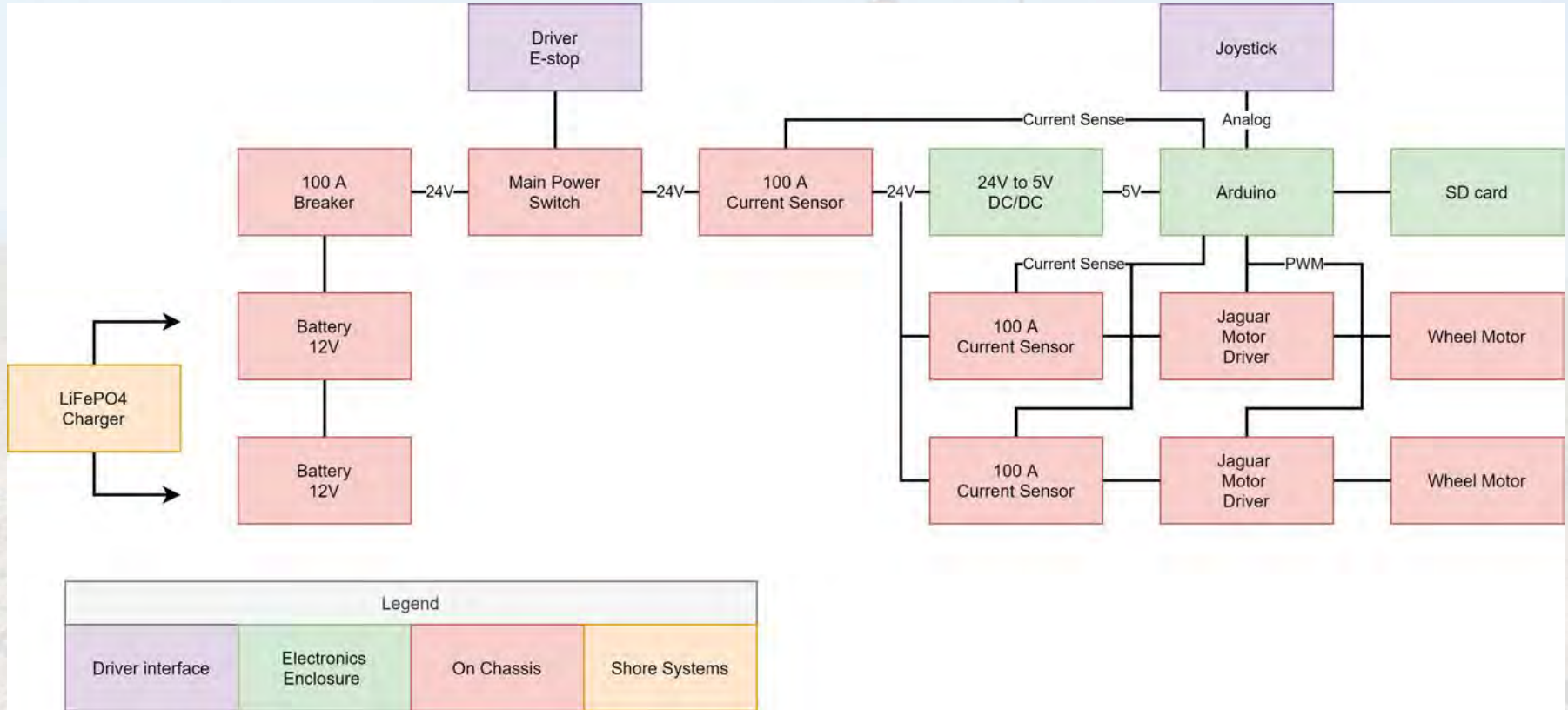

Vehicle Operations

- Vehicle designed around a 2 tests per day schedule:
 - 1 test in the AM (expected less than 4 hours)
 - 1-2 hours break mid-day for lunch and battery charging/vehicle configuration change
 - 1 test in the PM (again, less than 4 hours)
- Expected range: 8-10 km at full speed over level ground
- Expected runtime: ~45 minutes at full power

Hardware Interface

- ROS needs to interface with motors and sensors
 - Most sensors are USB devices, with existing libraries
 - Analog sensors can use an Arduino (or similar) for digitization
- Motors/actuators require a specialized solution
 - Motor drivers can use CANbus
 - Common standard used by the lab
 - Battery BMS uses CAN to communicate charge information
- Cradlepoint cell router communicates over ethernet

Software Overview

- Utilize Robot Operating System (ROS) for modular software architecture
 - Open-source software available for navigation basics
 - Testing of multiple sensors with same navigation software
 - Run identical rover software on multiple rovers (X-Hab Rover, RMP440, Raven)
- Astronaut following requires navigation algorithm with constantly changing goal
 - Use stereo cameras to find astronaut via fiducial markers
 - Investigating random sampling, graph search algorithms

Software Block Diagram

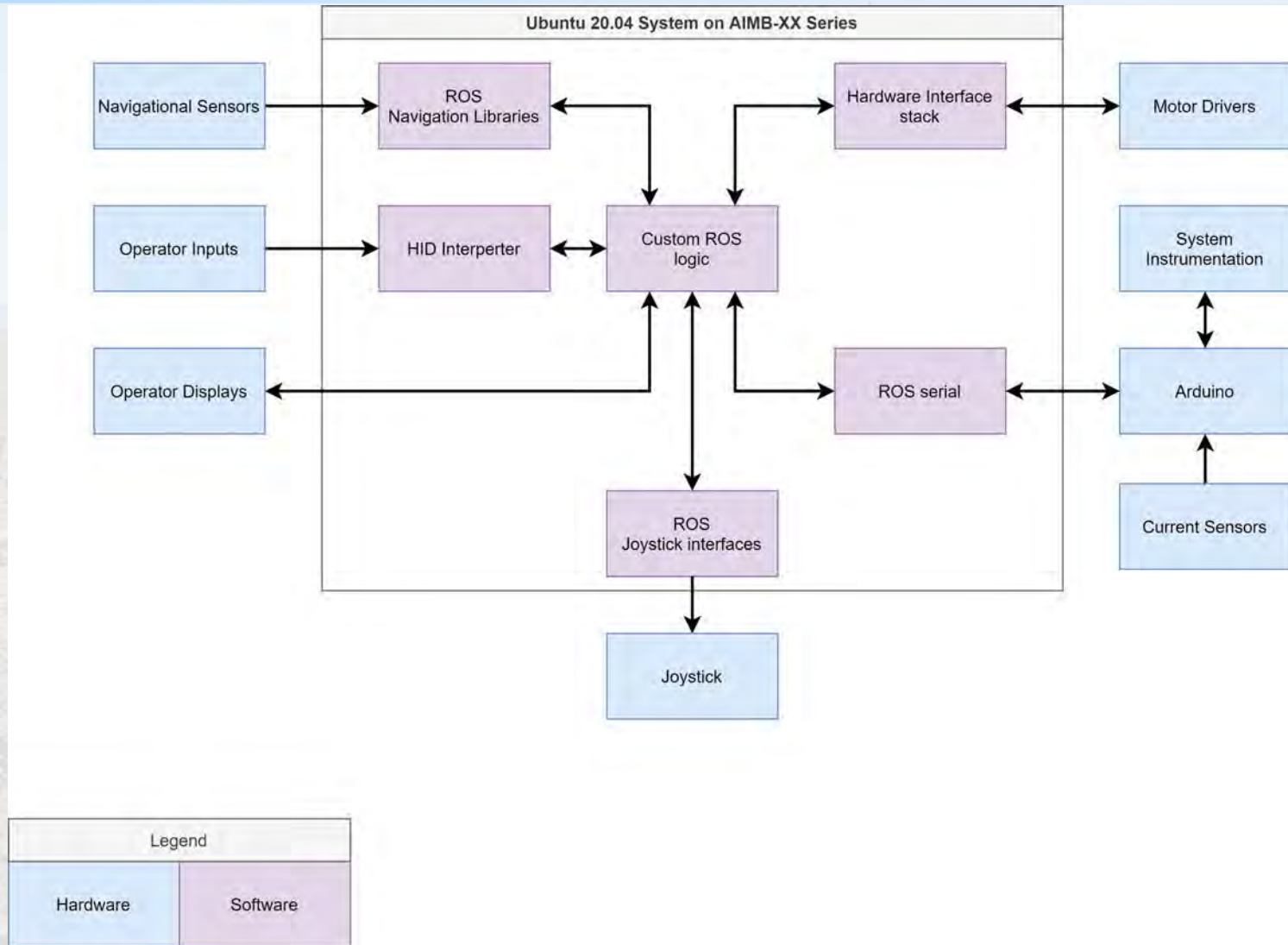

Astronaut Following Algorithms

- Speed $>$ optimality
- Graph search
 - Lifelong Planning A*
 - Algorithm deals well with dynamic environments
 - Field D*
 - Linearly interpolates between grid points on costmap
- Random sampling
 - Not confined to grid environment
 - Stable-sparse rapidly-exploring random trees (SST/SST*)
 - Faster than traditional rapidly-exploring random tree algorithm
 - Account for complex vehicle dynamics
 - SST* uses extra time to create more realistic paths

Software Test Plan

- Testing in simulation
 - Develop navigation/astronaut-following algorithms
 - Conduct testing with false goals and obstacles in Gazebo simulated environment
- Test software with sensors on other rover(s)
 - Raven and RMP440
 - Experiment with sensor placement, astronaut following
- Integration with rover hardware
 - Determine optimal sensor placement on chassis
 - Determine ideal path planning algorithm for astronaut following

Hardware Test Plan

- Electronics will be tested on existing rover hardware (Raven)
- Non-design specific systems (e.g., wheel hub motors and geartrains) will be prototyped and tested ahead of final design
- Basic performance (e.g., drawbar pull, speeds) will be tested on campus
- Operations testing will be performed in UMd Moonyard with simulated EVA crew

UMd X-Hab Rover 2021: Open Issues

- Effects of COVID restrictions on fabrication, assembly, and testing
- Ability to build and test a complete rover in remaining time
 - Critical part lead times
 - Schedule margins to account for necessary redesigns/rebuilds
 - We anticipate that primary testing will not occur during X-Hab 2021 nominal period
- Is NASA more interested in this as a lunar design or as an Earth analog vehicle?

A photograph of a rover in a desert landscape, overlaid with the text "Backup Slides". The rover is a six-wheeled vehicle with a complex mechanical structure, including a camera mast and a robotic arm. It is positioned in the center-right of the frame. The background is a vast, flat, sandy desert under a clear blue sky. The text "Backup Slides" is written in a large, bold, black font, centered over the rover and the landscape.

Backup Slides

Preliminary Mass Budget

VERTEX Mass Sheet

Item	lbs	kg	Quantity	lb Subtotal	kg Subtotal
Tires	42.0	19.1	4	168	76
Wheels	25.0	11.3	4	100	45
Drive Motors	17.0	7.7	4	68	31
Drive Gearboxes	14.3	6.5	4	57	26
Chassis	65.0	29.5	1	65	29
Battery	220.5	100.0	1	220	100
Linear Act	14.0	6.4	4	56	25
Steering Motors	4.4	2	4	18	8
Steering Gears	2.2	1	4	9	4
Wheel Linkages	11	5	4	44	20

Vehicle Total lb	Vehicle Total kg
805	365
With 30% Margin	With 30% Margin
1047	475

Risk Assessment and Mitigation

- Rover driver safety is a priority
- Apply standard vehicular safety systems to rover
 - Rollcage for rollover protection
 - Body restraints/seatbelts
 - Emergency stops located in multiple locations
- General power system safety
 - Breakers and fuses in power systems
 - Drive interlocks while system is on shore power
- Dealing with COVID and shared surfaces
 - Cleaning contact surfaces such as joysticks, e-stops, and operator control panels

Front Impact

- Fully loaded 5G impact with margin

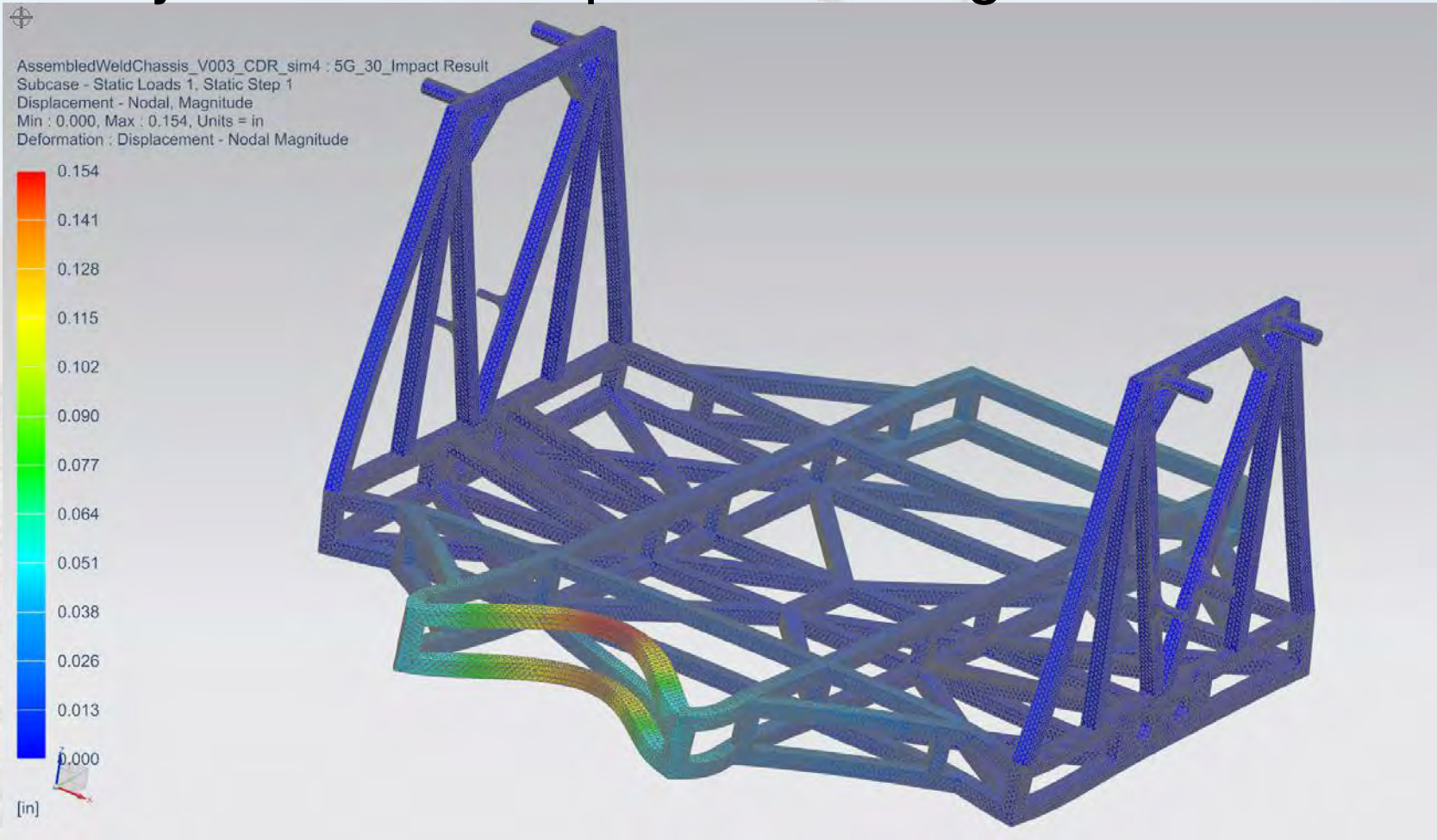

Front Impact

AssembledWeldChassis_V003_CDR_sim4 : 5G_30_Impact.Result
Subcase - Static Loads 1, Static Step 1
Strain Energy Percentage - Elemental, Scalar
Min : 0.0010, Max : 0.0848, Units = Unitless
Deformation : Displacement - Nodal Magnitude

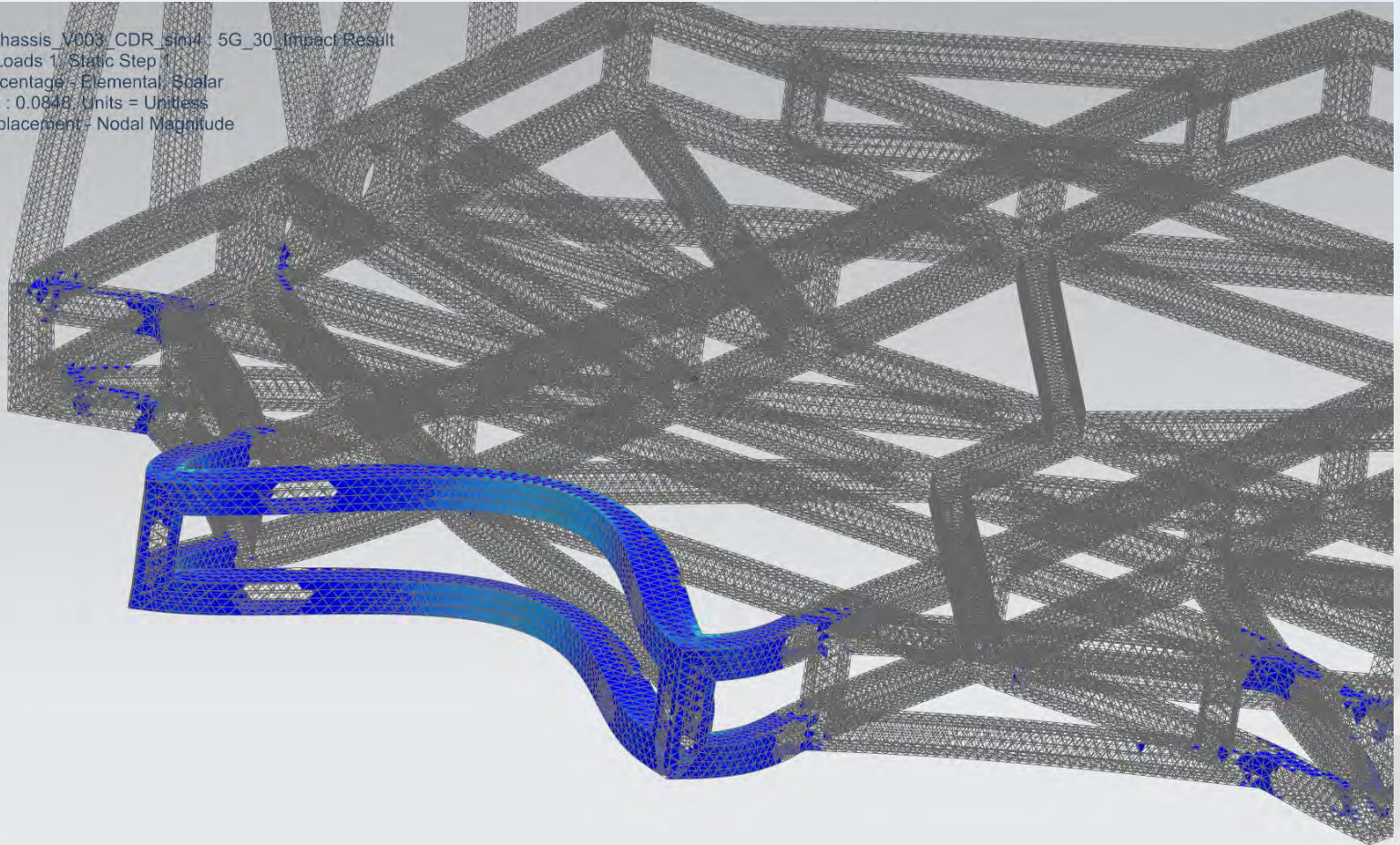
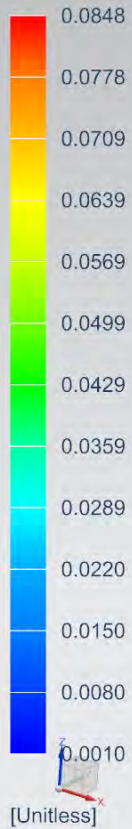

Torsion

- Fully loaded two point rocking torsion with margin

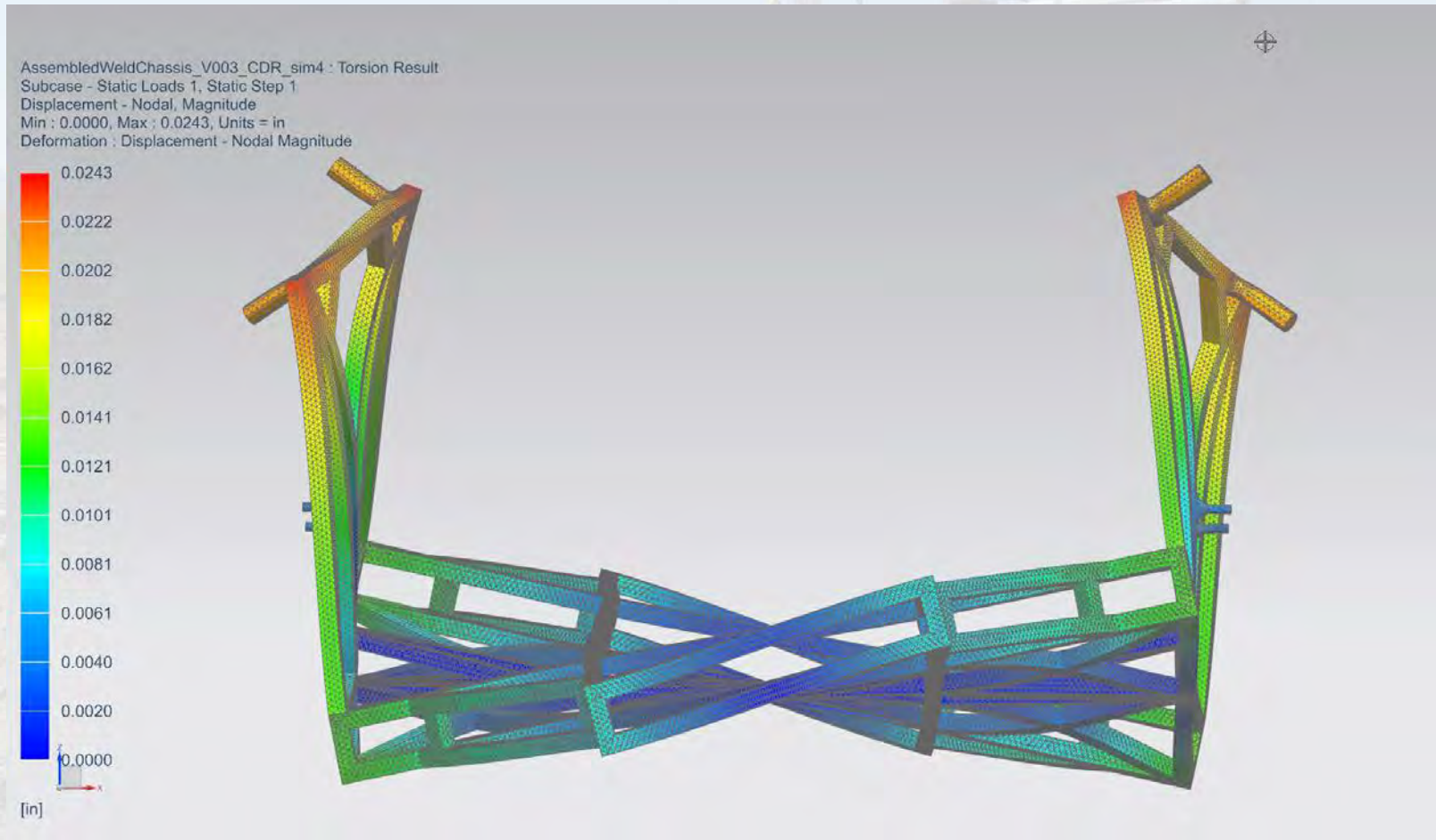

Torsion

AssembledWeldChassis_V003_CDR_sim4 : Torsion Result
Subcase - Static Loads 1, Static Step 1
Displacement - Nodal, Magnitude
Min : 0.0000, Max : 0.0243, Units = in
Deformation : Displacement - Nodal Magnitude

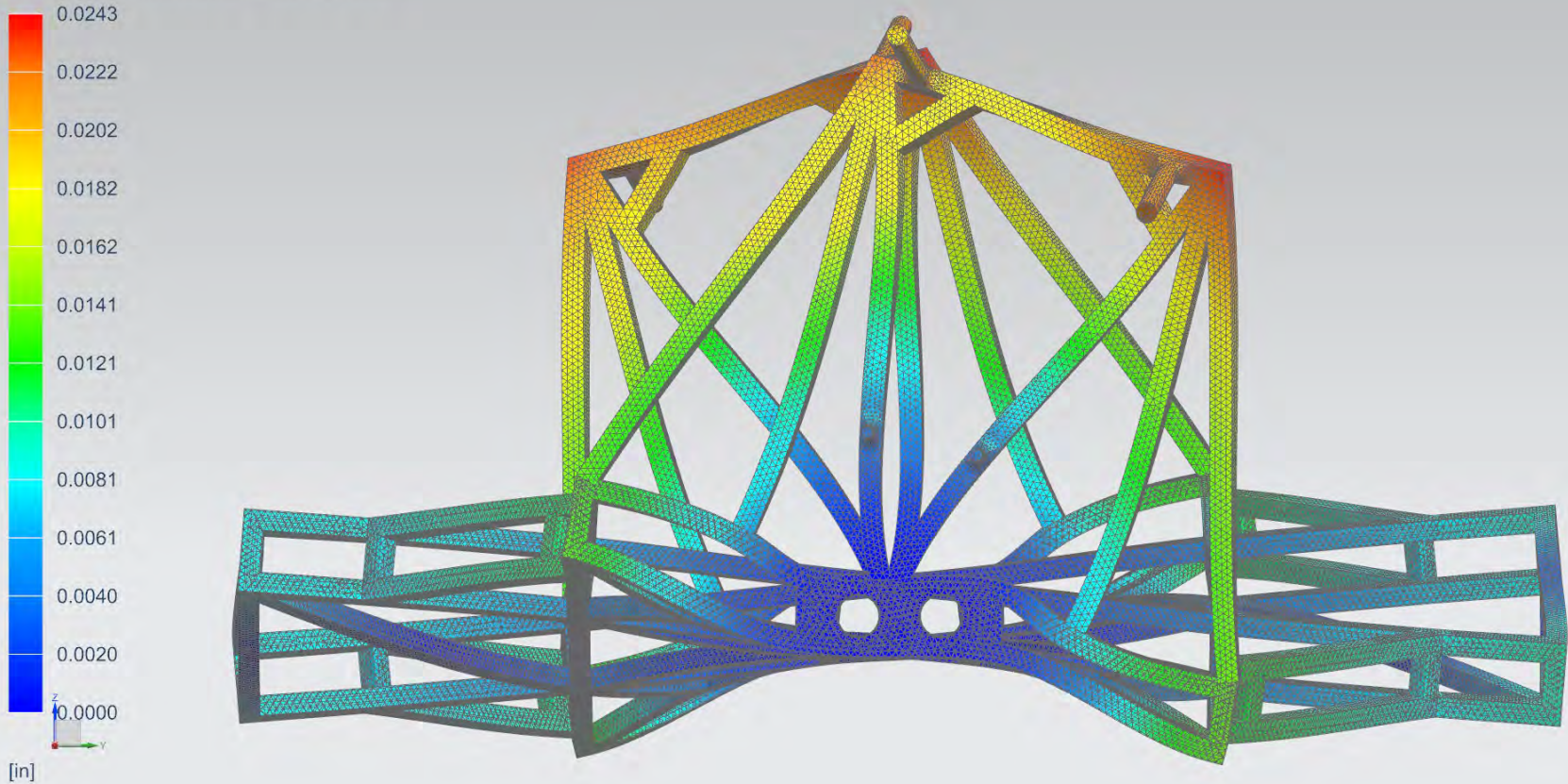

Torsion

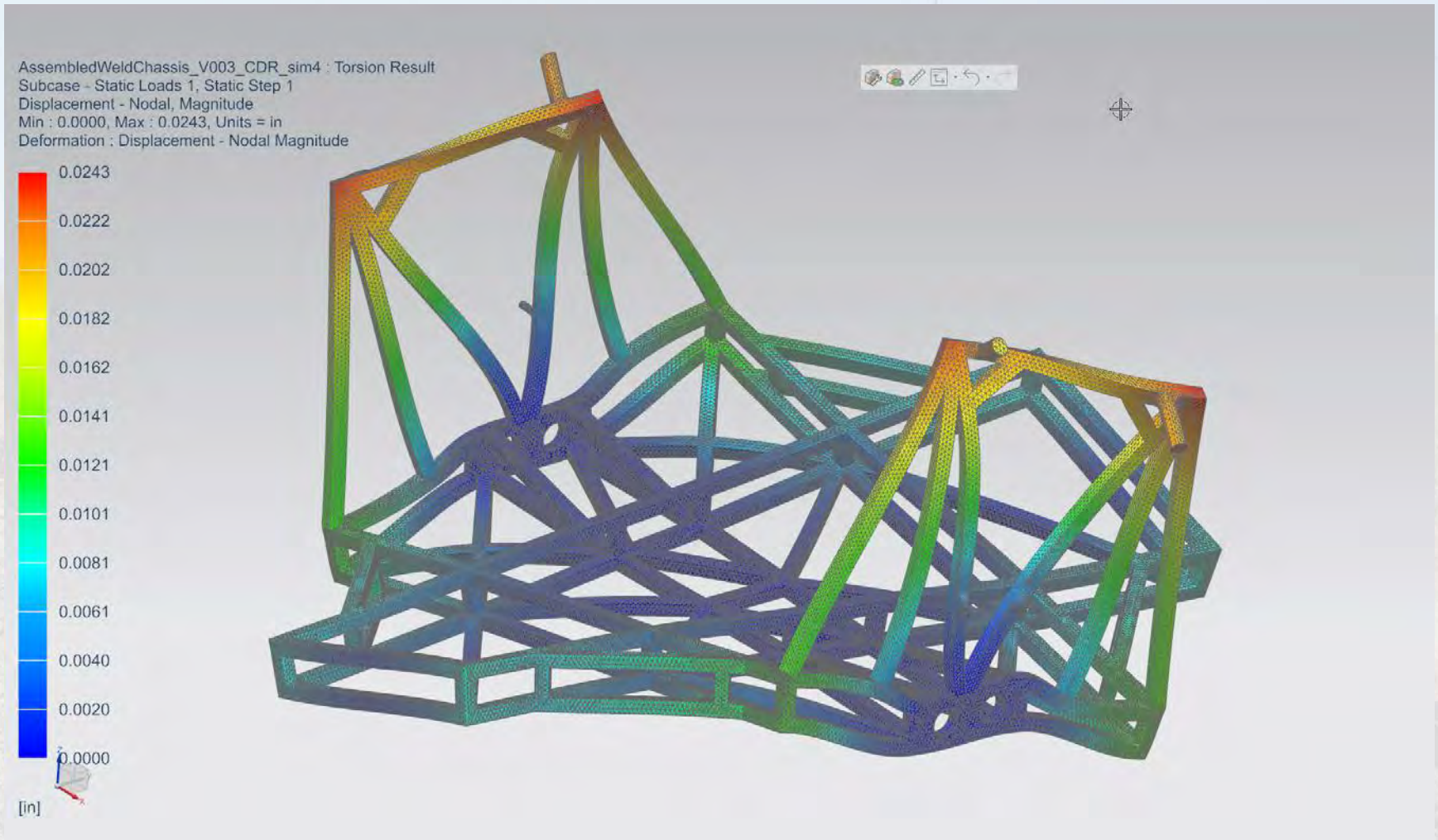

Bending (front/rear lift)

- Fully loaded front/rear bending with margin

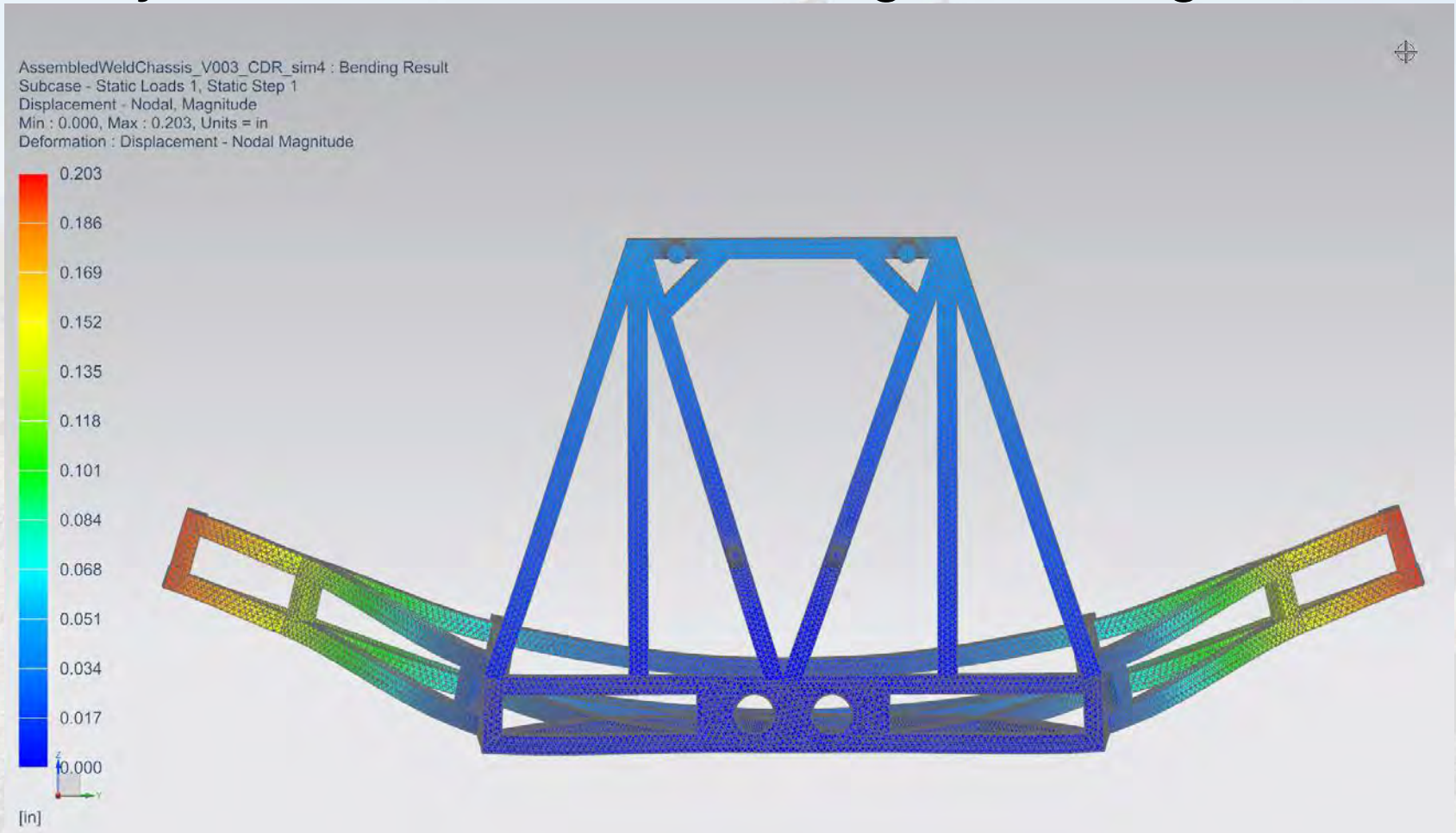

Bending (front/rear lift)

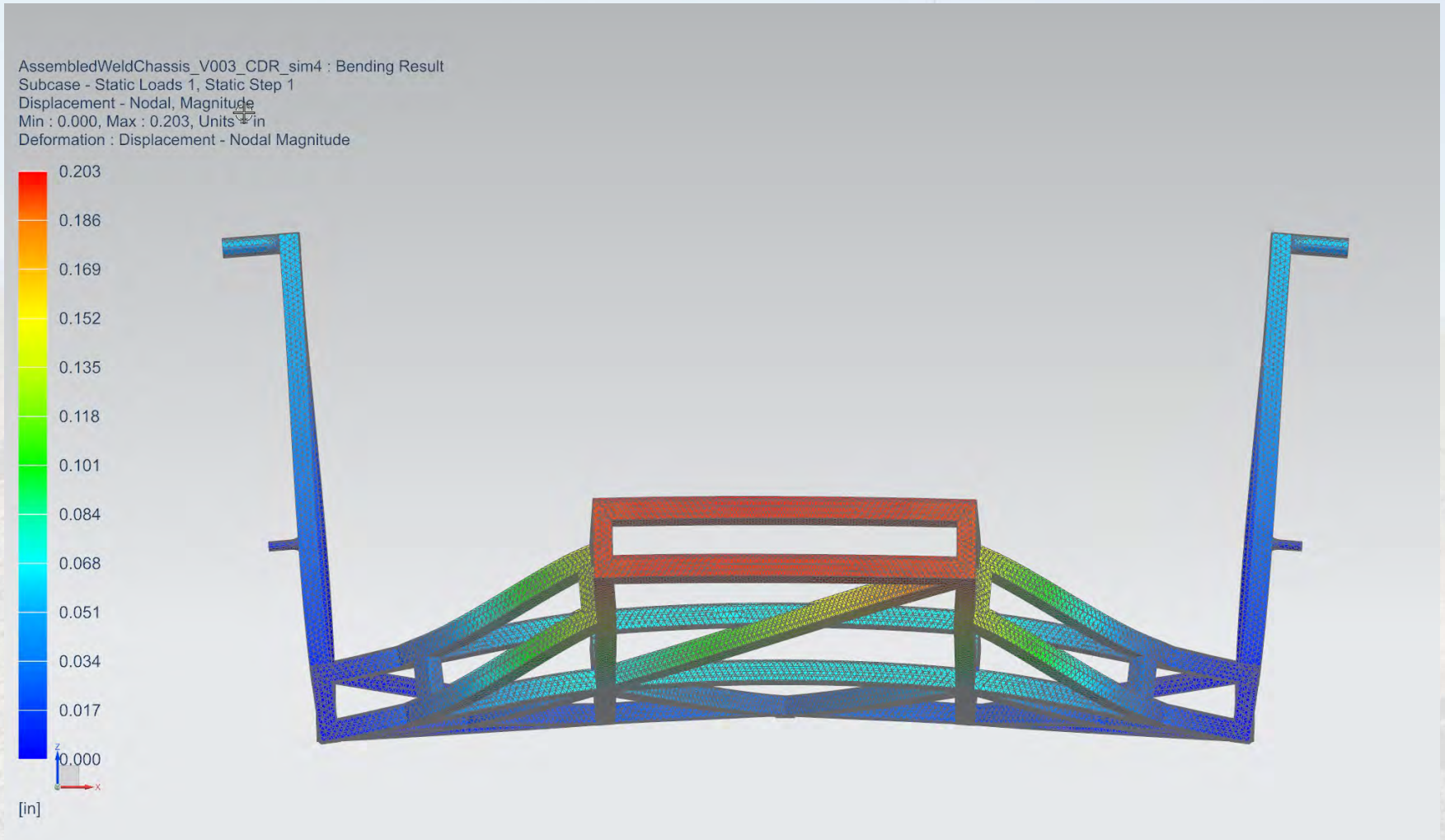

Bending (front/rear lift)

AssembledWeldChassis_V003_CDR_sim4 : Bending Result
Subcase - Static Loads 1, Static Step 1
Displacement - Nodal, Magnitude
Min : 0.000, Max : 0.203, Units = in
Deformation : Displacement - Nodal Magnitude

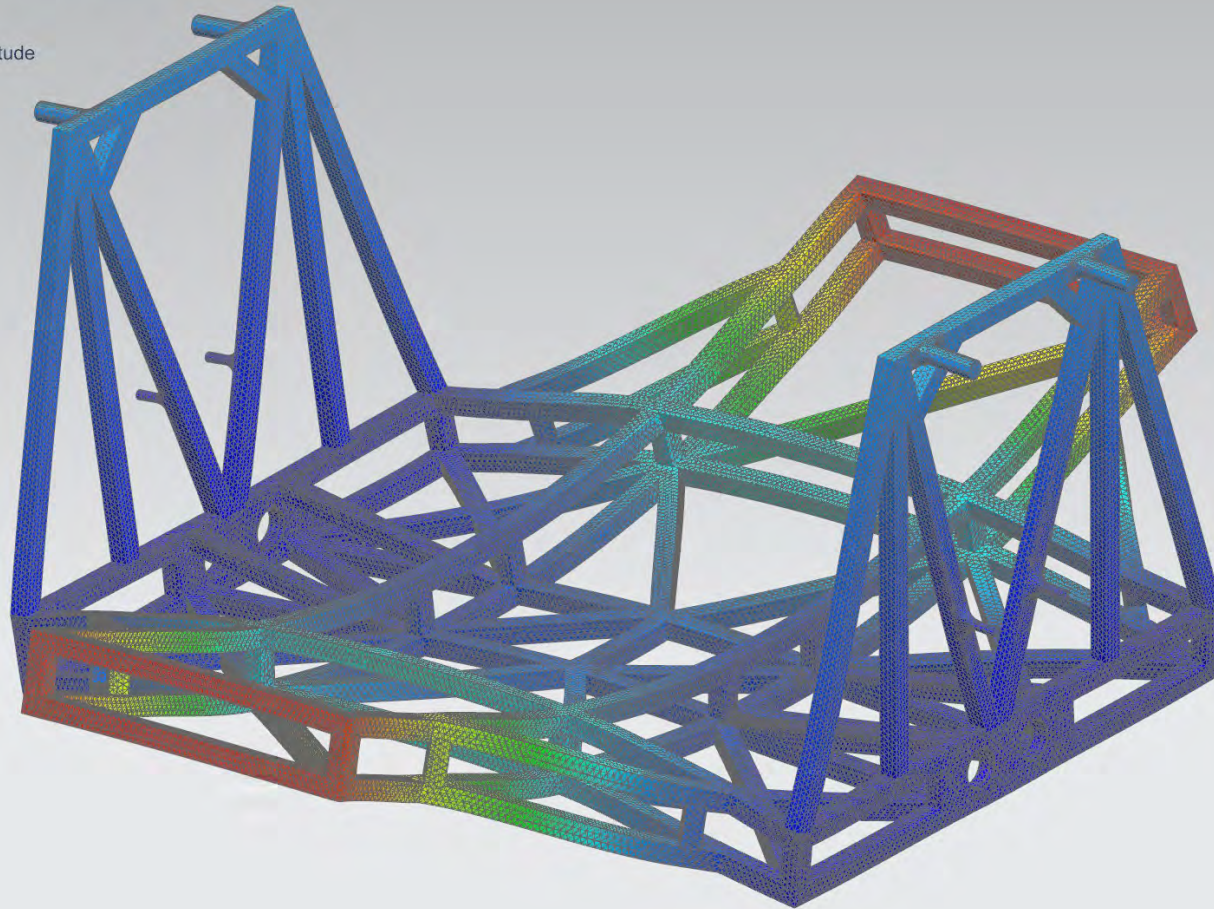
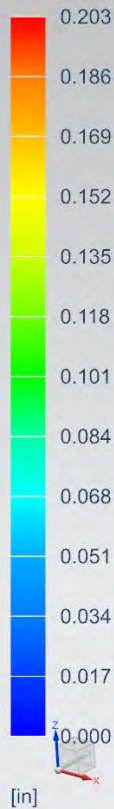

Bending (Side)

- Fully loaded wheel attachment bending with margin

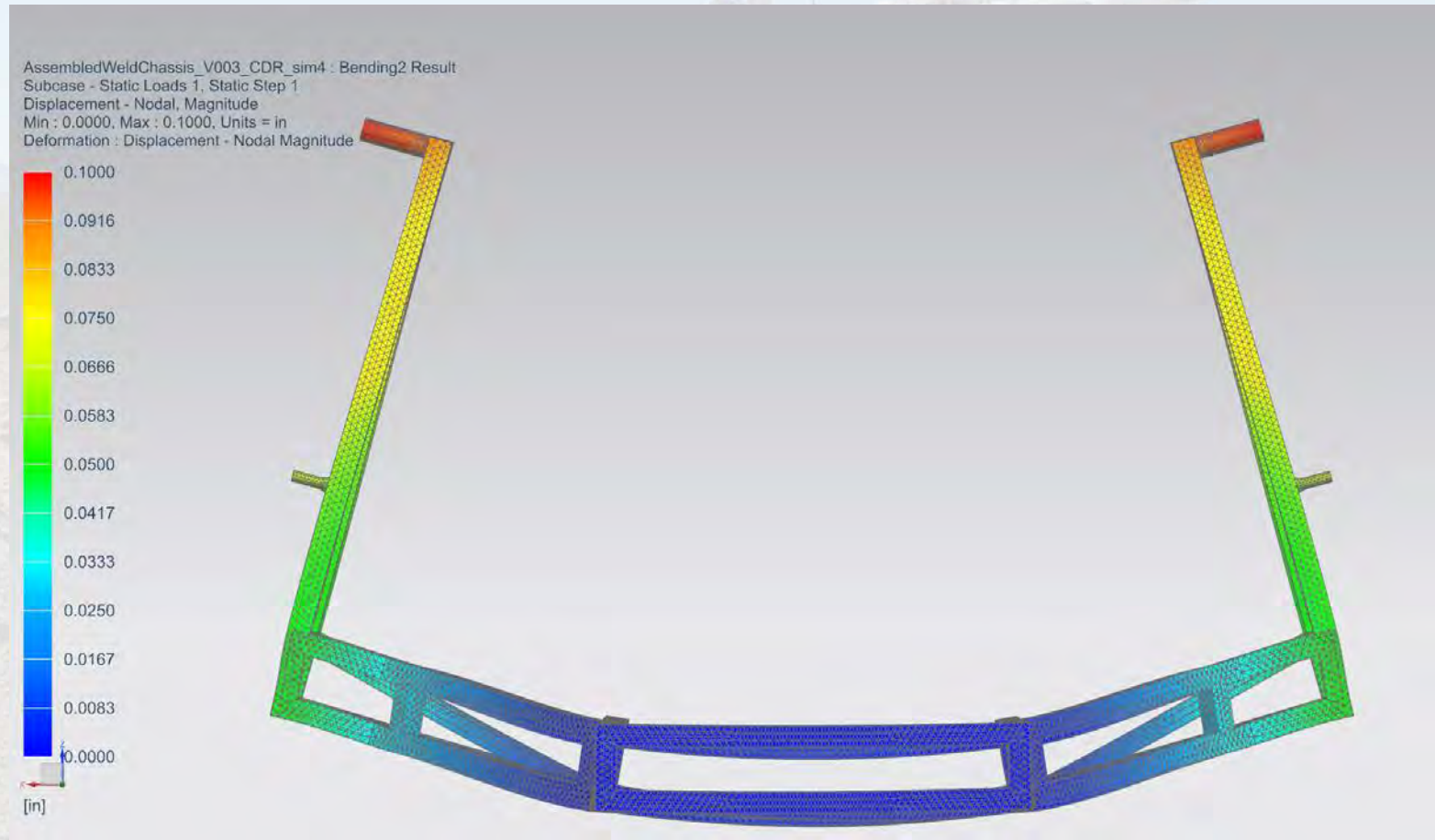

Bending (Side)

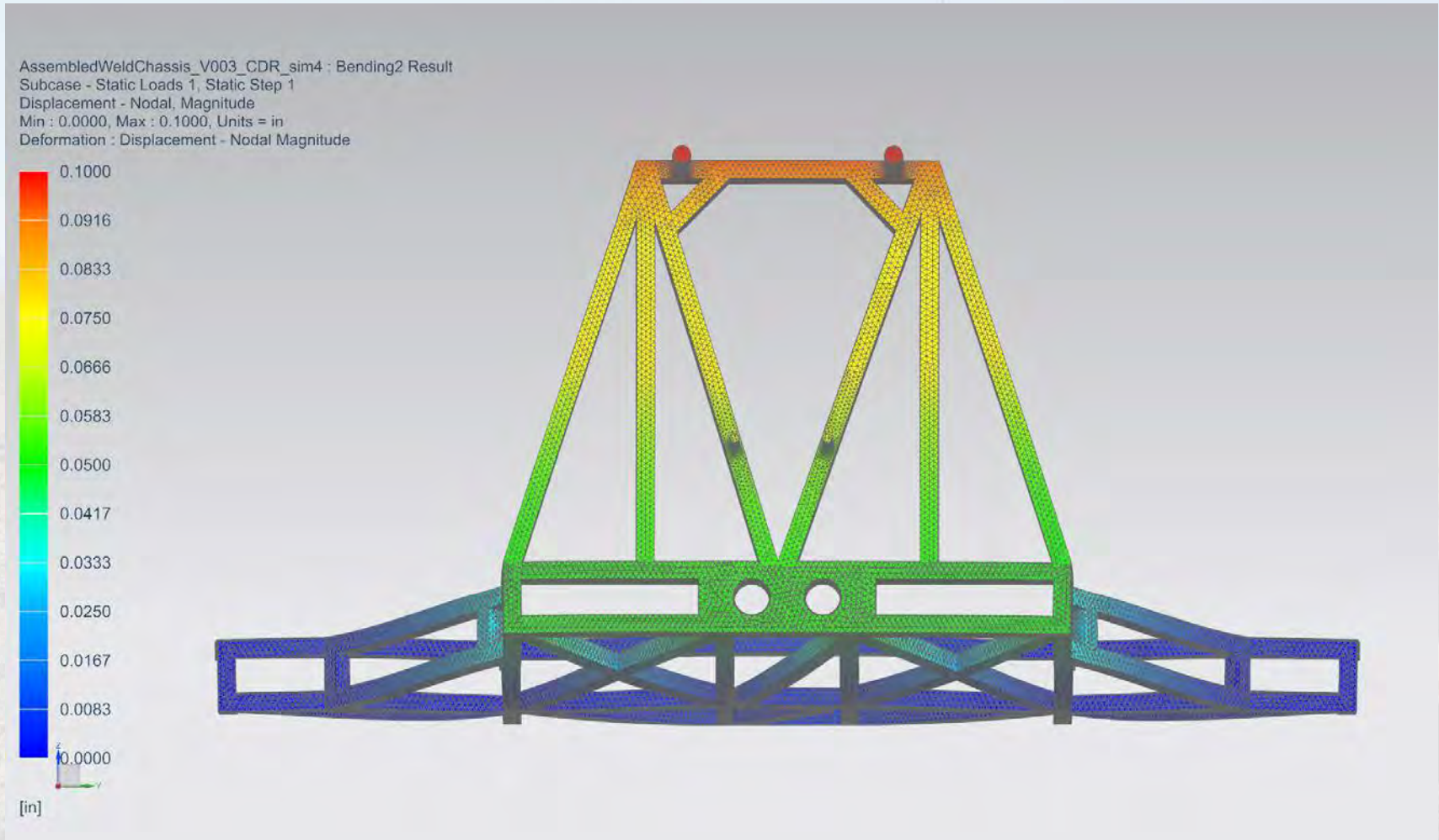

Bending (Side)

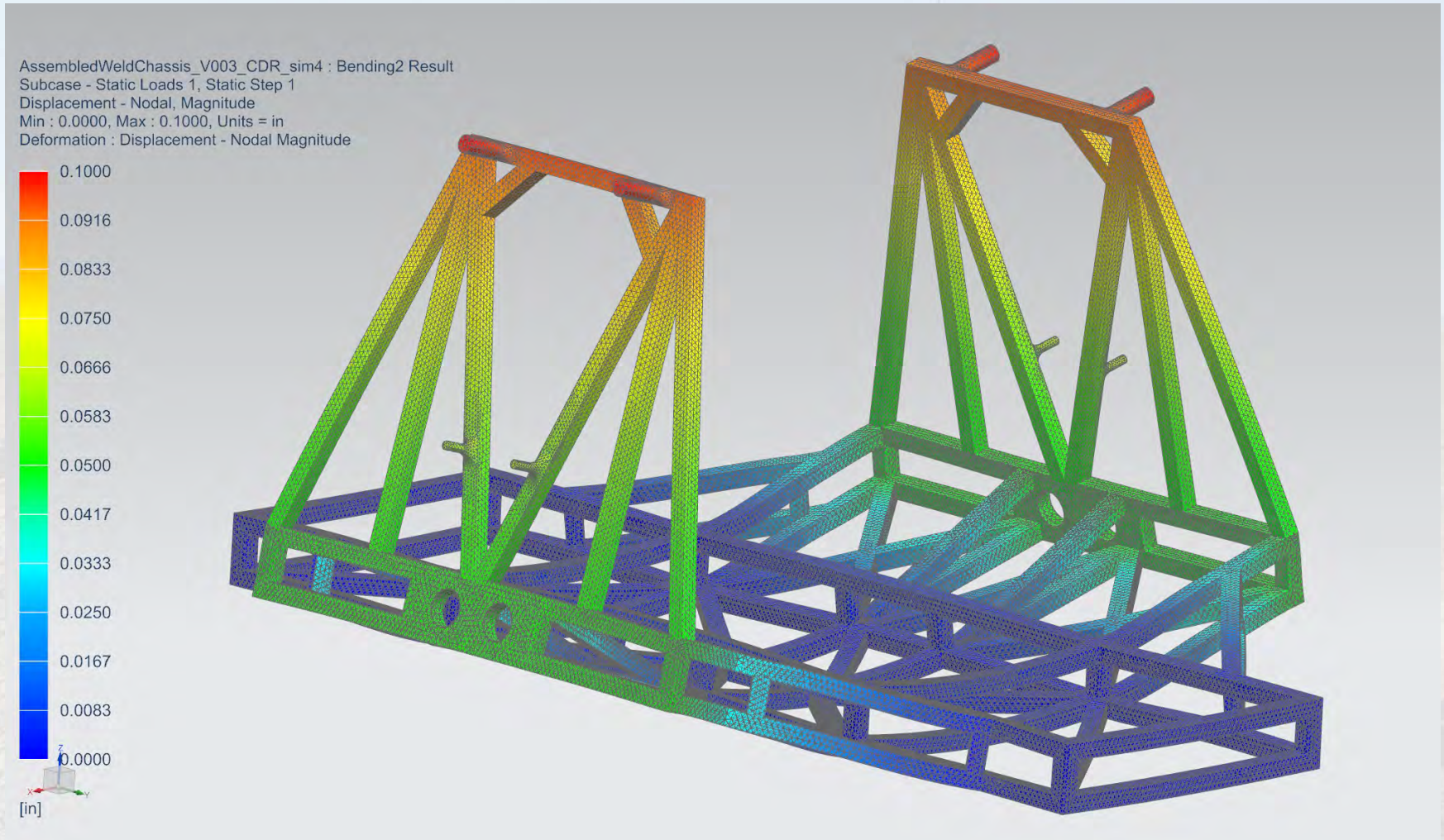

Operations Diagram

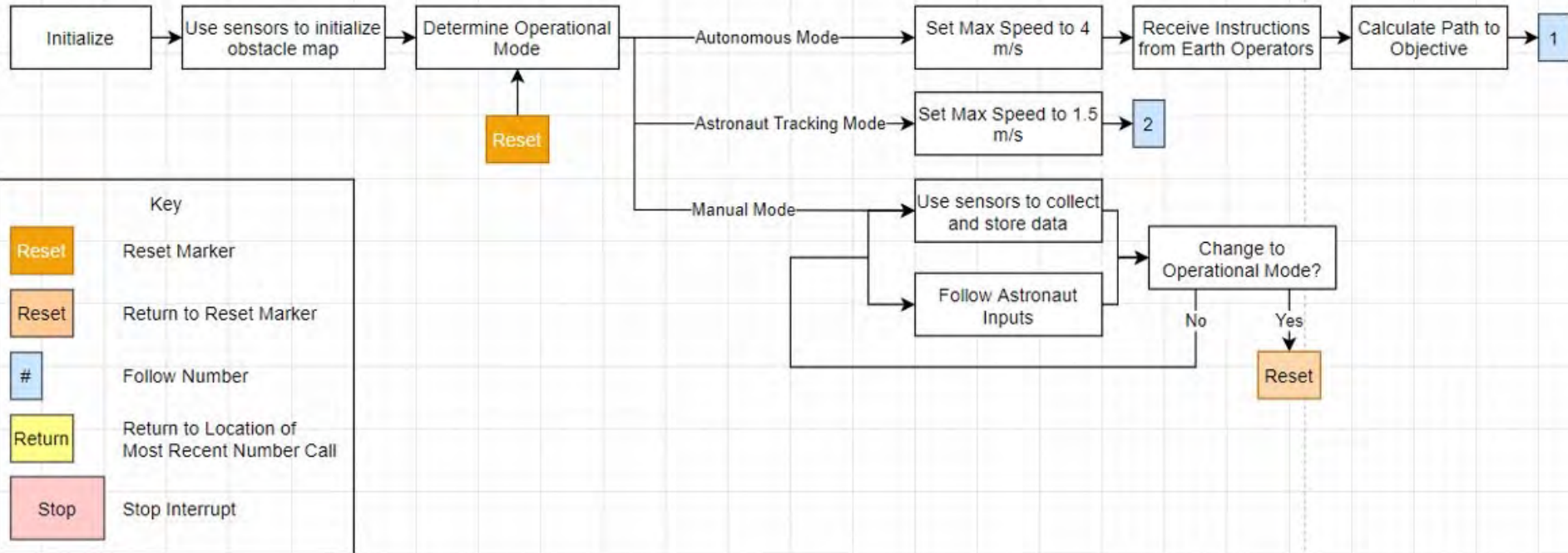

Operations Diagram - Autonomous

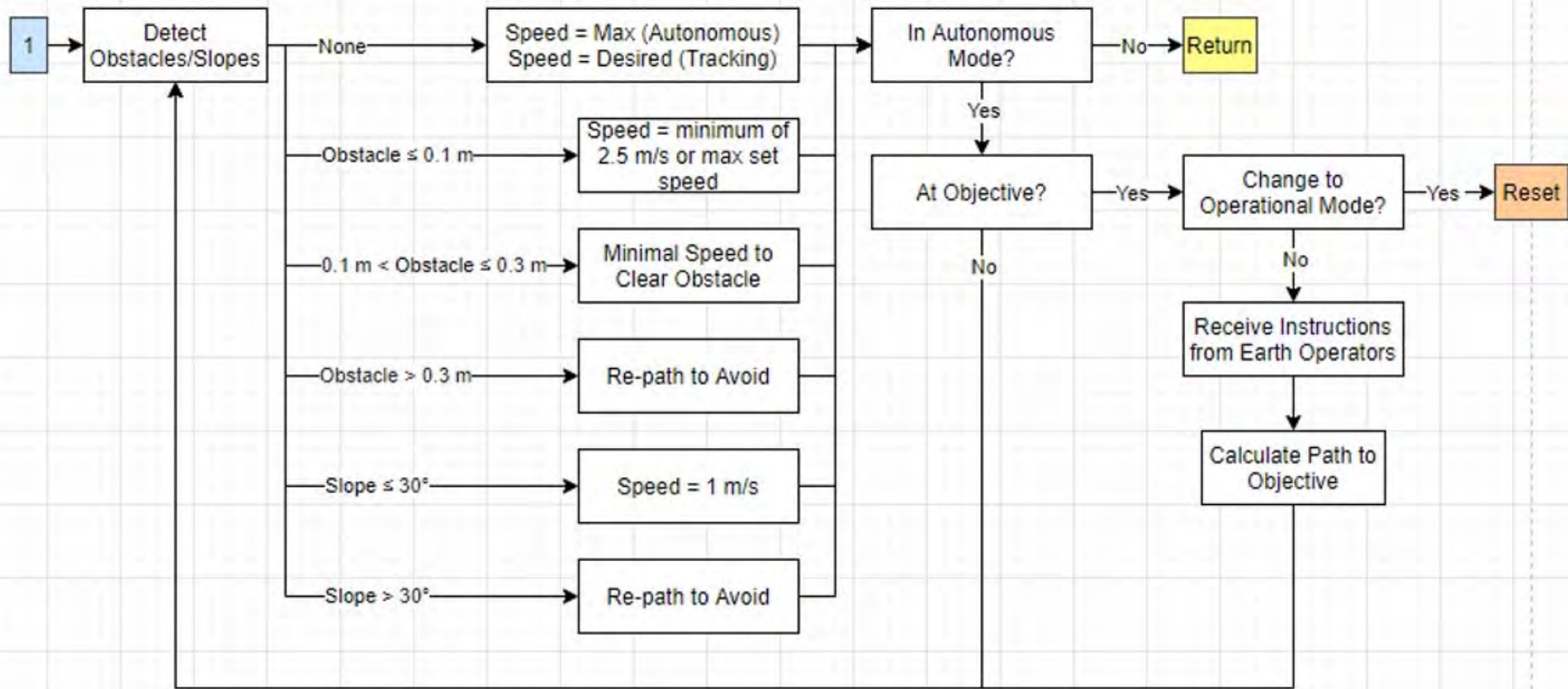

Operations Diagram – Tracking

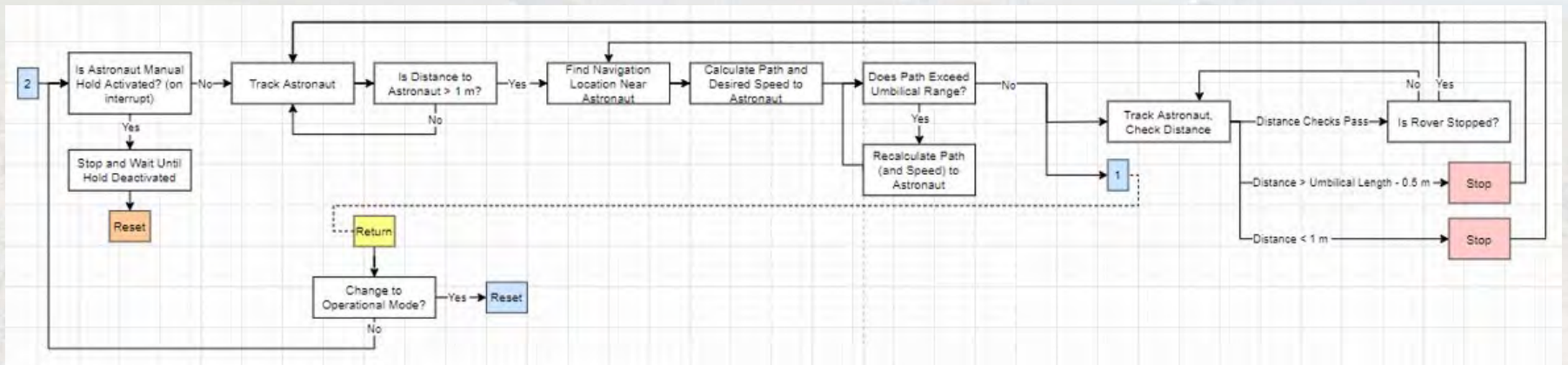

VERTEX* Full Assembly



***Vehicle for Extraterrestrial Research, Transportation, and EXploration**

UNIVERSITY OF
MARYLAND

Slightly Unfolded

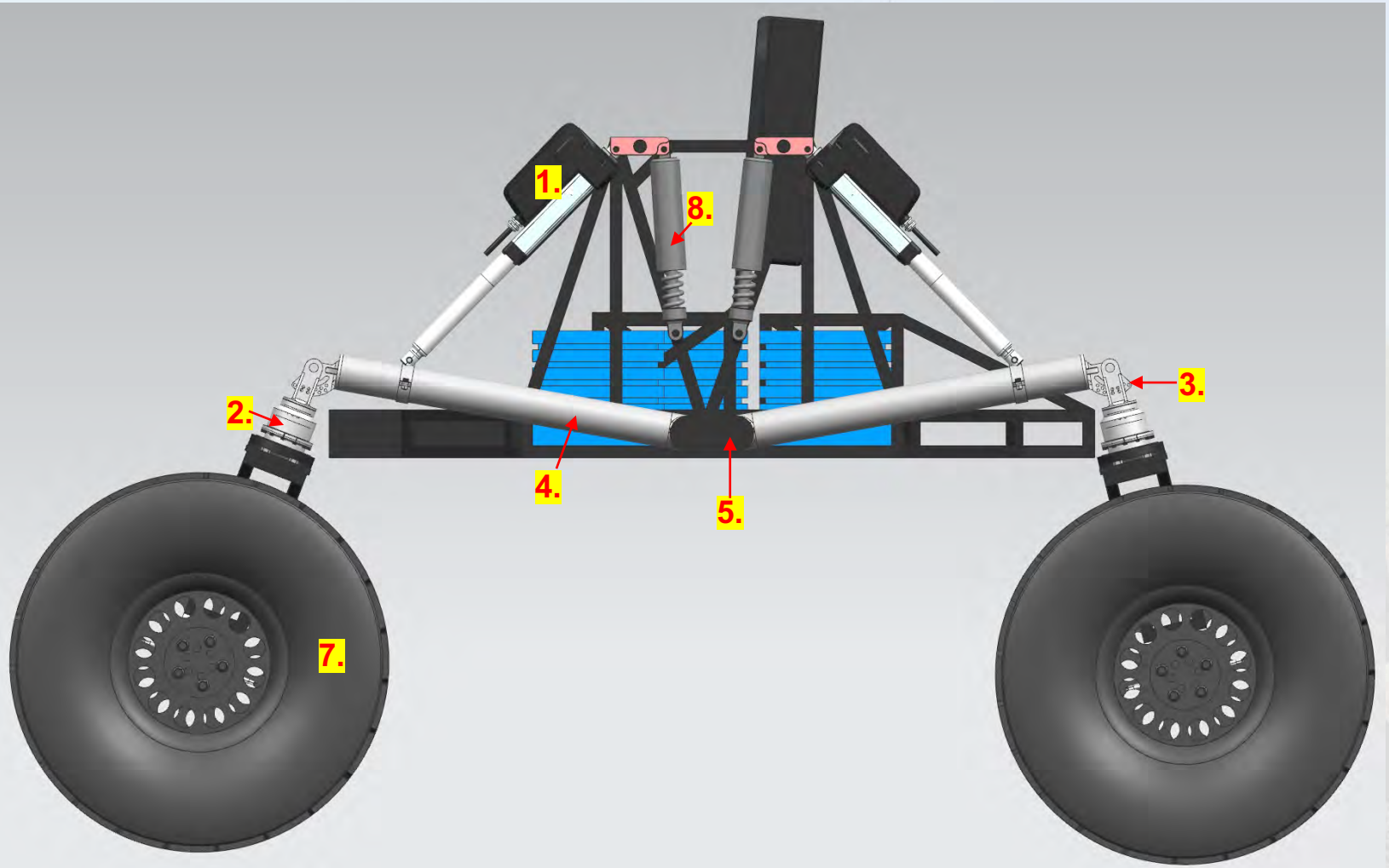

Front Wheel Steer (Ackermann)

