

# Nuclear Electric Propulsion Brayton Power Conversion Working Fluid Considerations

Rodger Dyson<sup>1</sup>, D.V. Rao<sup>2</sup>, Matthew Duchek<sup>3</sup>, Christopher Harnack<sup>3</sup>, Robert Scheidegger<sup>1</sup>, Lee Mason<sup>4</sup>, Al Juhasz<sup>1</sup>, Luis Rodriguez<sup>1</sup>, Ronald Leibach<sup>1</sup>, Steven Geng<sup>1</sup> and Daniel Goodell<sup>1</sup>

<sup>1</sup>NASA Glenn Research Center, Cleveland, , 44135

<sup>2</sup>Los Alamos National Laboratory, Santa Fe, New Mexico, 87545

<sup>3</sup>Analytical Mechanics Associates, Inc., Hampton, Virginia, 23666

<sup>4</sup>NASA Headquarters, Washington, D.C, 20546

Primary Author Contact: 216-433-9083, Rodger.W.Dyson@nasa.gov

NASA has considered Nuclear Electric Propulsion (NEP) for high  $\Delta V$  missions since the late 1950s, but the current technology readiness level of the requisite powertrain needs to be raised for such a mission. The powertrain includes reactor, power conversion, power management, electric propulsion, and thermal management components that must be integrated to minimize system  $\alpha$  (kg/kWe) and to finalize a propulsion system architecture within the 2025-2027 timeframe requires advancing these component technologies to technology readiness level (TRL) 5 and Advancement Degree of Difficulty (AD<sup>2</sup>) 3 in an expeditious manner with minimal risks. This paper will only address the power conversion (heat to electric) components of that system. Based on both internal and industry studies, a primary conclusion of this work is that a single-spool supercritical Xe-He radial flux Brayton heat engine combined with a permanent magnet synchronous alternator can potentially be developed with the least technical risk to meet the technology readiness schedule and required NEP system performance metrics.

## I. Introduction

As part of the development of a technology maturation plan for a potential NEP vehicle, critical technology elements (CTE) have been identified for further development (Refs. 1-6) as shown in Figure 1. The level of development and the potential performance of these technologies varies widely, and none have been tested to the power levels required for a MWe-class NEP system in an appropriate operating environment, even if multiple power conversion units are used to meet total power and system reliability requirements.

Recently, the Mars Transportation Architecture Study (MTAS) study (Ref. 2) recommended as a highest priority to design, build, and test a 500 kW Brayton power conversion unit (PCU) with either CO<sub>2</sub> or He-Xe working fluid for 1000 h under both design and off-design transient conditions. The recommendation from the National Academies of Science Nuclear Electric Propulsion report (Ref. 4) is, “NASA should rely on (1) extensive investments in

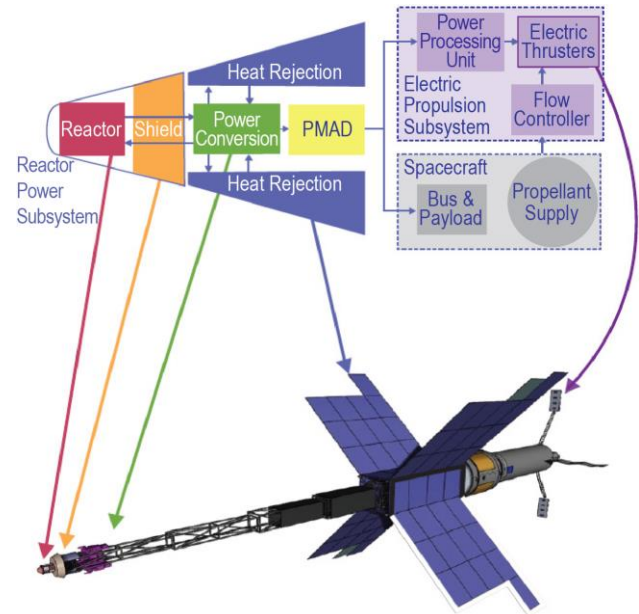

Fig. 1. Critical technology elements of NEP vehicle (Ref. 4)

modeling and simulation (M&S), and (2) ground testing (including modular subsystem tests at full-scale and power)”. And the Space Technology Mission Directorate (STMD) Space Nuclear Propulsion (SNP) program has the goal of establishing a verified baseline NEP configuration within the 2025-2027 timeframe (Ref. 6).

The PCU includes the Brayton heat engine, recuperator, reactor heat exchanger, radiator heat exchanger and an embedded alternator that delivers three-phase high voltage power using the heat produced from the microreactor system. Therefore, a focus of the PCU technology maturation effort is to develop and test a PCU that is compatible with both the microreactor and the embedded alternator while also being optimized for minimizing the overall NEP power and propulsion system architecture system alpha (i.e., kg/kWe). This report builds upon the previous studies and explores the detailed system impacts that the Brayton heat engine working fluid has on the overall risk and PCU architecture under a variety of operating condition assumptions.

## II. Space-Based Closed-Cycle Brayton Background

The advantages of dynamic Brayton power conversion include high efficiency, long life, and scalability to high power (Ref. 7). For these reasons, NEP dynamic power conversion system development has occurred intermittently over the past six decades. For example, the Brayton rotating unit (BRU) project (1968-1978) was aimed at a high-efficiency power conversion system for isotope, reactor, and solar receiver heat sources (Ref. 8). It was designed for operation from 2.25-10.5 kWe depending on the charge pressure of the working fluid and a He-Xe mixture with a molecular weight (MW) of 83.8 g/mol. Four BRU units shown in Figure 2 were fabricated by AiResearch and tested at NASA. A Brayton heat exchanger unit was also built that combined a 95% effective gas-to-gas recuperator and a Dow-Corning 200 gas cooler.

The BRU system was designed for operation at a turbine inlet temperature of 1,144 K, compressor inlet temperature of 300 K, and maximum pressure of 310 kPa. The rotating assembly consisted of a radial turbine, radial compressor, and a liquid-cooled alternator on tilt-pad bearings operating at 36,000 rpm. The project successfully demonstrated manufacturing and assembly methods, material compatibility, and high efficiency conversion (up to 32%). The BRU mass shown in Figure 2 was 65 kg, and the combined recuperator/heat exchanger was 200 kg.

Numerous reports describe the performance testing conducted with the BRU system (Ref. 9). The BRU system was also endurance tested accumulating more than 38,000 h of operation without degradation of the moving parts (but with some recuperator fatigue observed from localized testbed stresses). In total, the four units compiled ~50,000 h of operation, demonstrating long-life performance. Near the end of the project, one of the units (BRU-F) was fitted with gas foil bearings and was operated at power levels up to 15 kWe (Ref. 10). Subsequent closed cycle space Brayton technology demonstration efforts were of lower power and of shorter duration or only designed but never built or operated as shown in Table I not withstanding a 22 kWe dual capstone test that demonstrated a shared working fluid arrangement for a potential gas cooled reactor design.

While these Brayton convertor demonstrations and designs provided an important baseline, NEP requires space Brayton engines that operate at least two orders of magnitude higher power, and the low TRLs of high-power candidate technologies result in system analyses with large uncertainties in the outputs. The relevance of NEP for ambitious space missions depends on the development and demonstration of a high-power system at the TRL levels necessary for sound architectural analysis. The SNP is pursuing a focused R&D program designed to advance PCU TRL/AD<sup>2</sup> levels in a stepwise fashion from their current approximate system level values of TRL 3/AD<sup>2</sup> 5 to TRL 4/AD<sup>2</sup> 3 and then TRL 5/AD<sup>2</sup> 3. Advancement in this

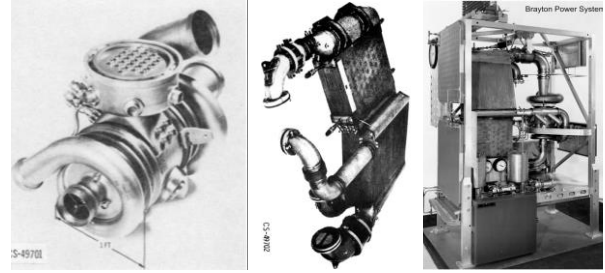

Fig. 2. BRU, Combined Recuperator/Radiator HX, and Life Testing Assembly

TABLE I. Closed-Cycle Brayton Heritage

Year	Project	Power (kWe)
1972 <sup>a</sup>	BRU	10.5
1978 <sup>a</sup>	Mini-BRU	1.3
1993	SSF SDPM	36
1997	SD GTD	2
2005	JIMO	100
2005	JIMO ATU	50
2009 <sup>a</sup>	Dual Capstone	22

<sup>a</sup> Tested Units

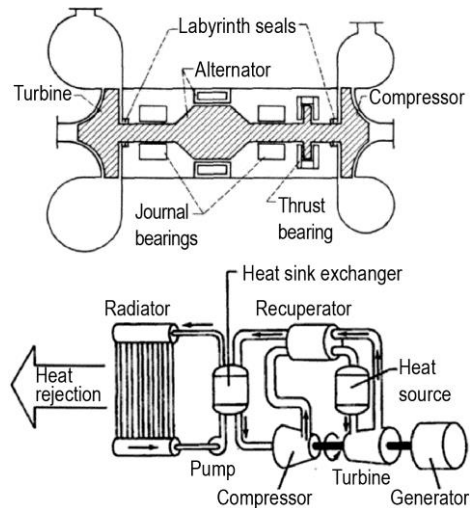

Fig. 3. Brayton Power Conversion Unit

manner will enable a data-driven down-selection to a specific technology solution. The R&D program focuses on hardware development and testing backed by the M&S efforts needed both to support power conversion system integration with the spacecraft and for projections of the required lifetime with as much validation as possible from sub- to full-scale ground testing in the time available.

## III. Brayton Power Conversion Architecture Options

Space Brayton power converter units are a closed-cycle version of a gas turbine engine or aircraft auxiliary power unit (APU). Typically, an inert gas binary working fluid, usually a mixture of He and Xe, is recirculated through a compressor and turbine coupled to a rotary alternator as shown in Figure 3.

Thermal input is achieved by either direct gas heating or through an intermediate heat exchanger. The cycle working

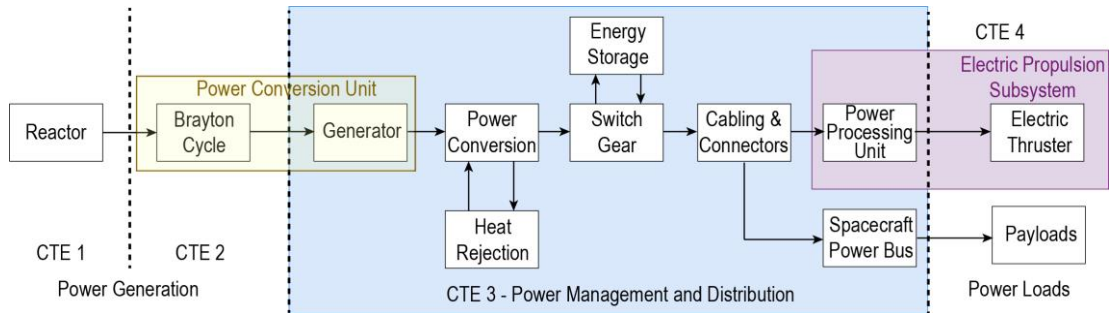

**Fig. 4.** NEP PCU integrated with reactor and PMAD

fluid is heated, expanded through the turbine, cooled, and then pressurized by the compressor. A recuperator improves cycle efficiency using the hot turbine exhaust gas to preheat the working fluid before it returns to the heat source. A gas cooler transfers the Brayton waste heat to a radiator, where it is rejected to space. The alternator provides three-phase, alternating-current (AC) electrical output that can be modified as necessary to either direct current (DC) or AC via a power management and distribution (PMAD) subsystem as shown in Figure 4.

Power conversion subsystems couple with the reactor at maximum temperatures compatible with the reactor coolant outlet temperature. For dynamic power conversion, this requires turbine material temperatures of 1100-1200 K, requiring at least superalloy materials (Ref. 11) or refractory metals if temperatures higher than 1150 K are necessary due to long-term material creep limitations. For the targeted total NEP power level of 1-2 MWe, individual converter output power levels of 200-800 kWe would be needed. Ideally, four 500 kW units would provide redundancy and enable the use of gas bearings for no-contact long-life operation. A direct-drive approach for powering thrusters from an AC conversion system would require AC output at 400-650 V for Hall thrusters or ~3000 V for ion thrusters, to be rectified for thruster beam power. Or in the case of lower voltage DC Magneto-Plasma-Dynamic (MPD) thrusters the power must still be distributed at high voltage to minimize cable mass. These high voltage and power requirements introduce new integration requirements for coil insulation and thermal management in the Brayton alternator.

Power conversion subsystem tests will also range from fundamental materials, thermodynamics, and fluid dynamics tests for heat exchangers, turbines, bearings, etc., to integrated, electrically heated power conversion subsystem tests. A similar approach has been used for lower power Brayton systems in the past. Vacuum or low-pressure operation with a thermally relevant background environment will be required under both startup and cruise conditions.

### III.A. Heat Engine Configurations

The turbomachinery, bearings, seals, and alternator configuration are highly dependent on the required power level (Ref. 12) as shown in Figure 5. In our power range of 500 kWe per closed Brayton cycle, the turbomachinery is

TM Feature	Power, MWe						
	0,3	1,0	3,0	10	30	100	300
TM Speed/Size	75,000/5 cm		30,000/14 cm		10,000/40 cm		3,600/1.2 m
Turbine Type	Single stage		Radial		Multistage		
	Single stage		Radial		Multistage		Axial Multistage
Bearings	Gas foil		Hydrodynamic oil				
			Magnetic		Hydrostatic		
Seals	Adv. labyrinth		Dry lift off				
Freq/alternator	Permanent Magnet		Wound, Synchronous				
Shaft Configuration	Dual/Multiple		Gearbox, Synchronous		Single shaft		

**Fig. 5.** Brayton power conversion unit scaling

typically radial and single stage with a speed between 25,000 and 75,000 rpm depending on the molecular weight/pressure of the working fluid. The bearings are normally gas foil since the combination of higher speed rotation and relatively low mass rotor provide sufficient bearing stiffness with the additional benefit of noncontact long-life operation (except during startup). The seals are long-life operation (except during startup). The seals are normally a noncontact advanced labyrinth or other close clearance seal, and higher working fluid pressures require more capable bearings and seals.

#### III.A.1. Compressor/Turbine Inlet Temperature Impact

The optimal Brayton compressor and turbine inlet temperature are highly dependent on the working fluid as well since both the radiator size and system alpha can be significantly impacted. For example, as shown in Figure 6, it is potentially possible to achieve a radiator area below 2500 m<sup>2</sup> (to fit within SLS payload fairing) using either a refractory 1400 K He-Xe or a superalloy 1200 K CO<sub>2</sub> working fluid Brayton (consistent with the MTAS study (Ref. 2)). As shown in Figure 7 the system alpha is reduced 25% when increasing the turbine inlet temperature by 200 K, but this increases creep and corrosion risk for both the He-Xe and CO<sub>2</sub> working fluid options.

In addition, these inlet temperatures are further limited by the maximum alternator and turbine temperatures. Typical temperature limits associated with the alternator and turbine are shown in Table II.

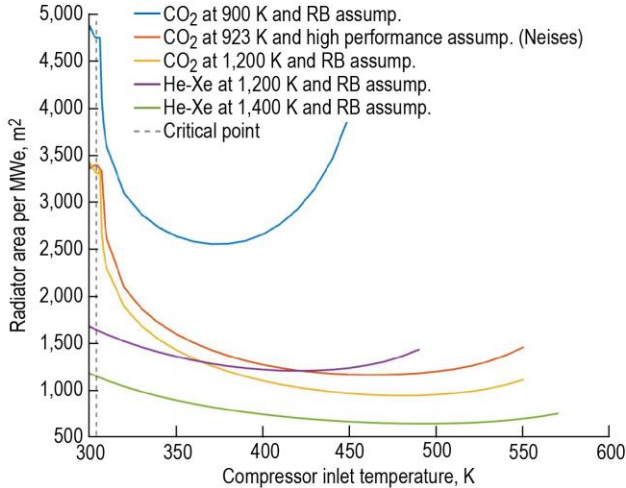

Fig. 6. Compressor temperature vs. radiator area (Ref. 13)

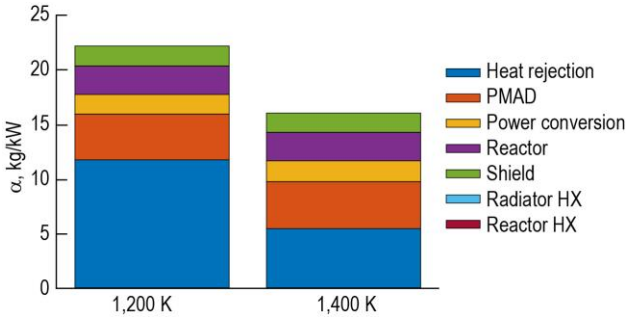

Fig. 7. Impact of turbine inlet temperature on system alpha at 2 MPa with He-Xe (Ref. 14)

TABLE II. Component Temperature Limits

Component	Location	Limit (K)
Hysol	Coil Potting	503
Polyamide	Coil Insulation	513
Magnet	Rotor Shaft	523
Turbine-CO <sub>2</sub>	Rotor Shaft	923 <sup>a</sup>
Turbine-He/Xe	Rotor Shaft	1150 <sup>b</sup>
Turbine-He/Xe	Rotor Shaft	1350 <sup>c</sup>

<sup>a</sup> Corrosion Limit (Ref. 15)

<sup>b</sup> Superalloy Creepage Limit

<sup>c</sup> Refractory Creepage Limit

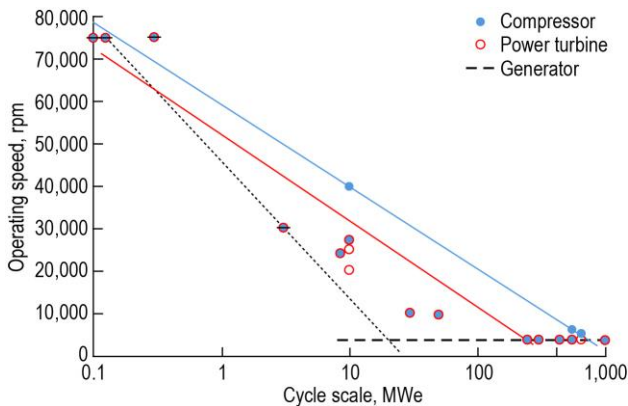

Fig. 8. Alternator and turbomachinery speed constraints

This introduces a compressor inlet temperature limit of  $\sim 500$  K unless a separate cooling system is employed for the coil. However, utilizing a separate alternator cooling system results in a larger magnetic air gap in megawatt scale alternators, a separate radiator system, and increases overall system complexity. The turbine inlet temperature limit is between 973 and 1400 K depending on the working fluid and turbine materials used unless special coatings or blade cooling is employed. But these turbine protective features also increase system complexity and therefore risk.

### III.B. Embedded Alternator Configurations

Current NASA space high power systems distribute less than 250 kW of power. For instance, the International Space Station produces  $\sim 240$  kW and the Gateway/ Power and Propulsion Element (PPE) is planned to produce around 60 kW of electrical power. Both systems operate at the 120-160 VDC level. Future NEP vehicles anticipate needing power greater than 1 MW, which means the alternator system will need to operate at higher voltages to avoid the large  $I^2R$  line losses associated with the distribution cabling. Increasing the distribution voltage decreases the current through the line and ultimately  $I^2R$  line losses. The challenge with increasing the distribution voltage is that there is currently no readily available and flight-certified high-voltage alternator equipment, for either AC or DC, and therefore significant leveraging of megawatt scale electric aircraft investment and industry support is expected.

At power levels below  $\sim 1$  MW, Brayton cycle technology generally becomes less efficient due to tip clearance and higher rotational speed windage losses. In addition, the required alternator rotational speed decreases (Ref. 16) as the power level is increased as shown in Figure 8. At the 500 kW-1 MW power conversion unit levels required for NEP, the typical rotational speed can be reasonably matched if properly integrated with a MW-scale alternator (20-30 krpm) if the proper working fluid and operating conditions are selected. This is important because we can't use a lubricated gearbox or dual spool in the space environment. High-voltage megawatt alternators have unique thermal, windage, rotor dynamic, and stress limitations when used in the space environment.

The limited availability of highly reliable, radiation hardened electronic components may further limit the voltage and current options for the alternator system, so minimizing the stresses on the power management and distribution components shown in Figure 4 is important and can be further facilitated by the alternator architecture and working fluid employed. For example, directly producing high voltage in the alternator simplifies the PMAD system but requires careful attention to the dielectric and thermal conductivity properties of the working fluid around the high voltage coils. Additionally, as was observed in the Jupiter Icy Moon Orbiter (JIMO) program, radiation

hardening to protect electronics against radiation damage from both the NEP system and from the space environment will be required (including alternator controller components).

In operation, the embedded alternator is motored from an energy source other than the reactor to start the turbine spinning. Once sufficient heat is transported from the reactor, the Brayton cycle becomes self-sustaining or “Boot-Strapped”. The Brayton alternator load is designed to maintain a constant torque load usually with three-phases or potentially using multiple phase and rotor dynamic compatible alternators on the same shaft to maintain electric thruster isolation.

In addition, the alternator topology will likely be either a permanent magnet synchronous topology or a switched reluctance topology depending on the required compressor inlet temperature and rad-hardened power electronics availability. High power is required (>500 kW) and at relatively high rotational speeds (>30 krpm with He-Xe or >50 krpm with CO<sub>2</sub>) which requires careful thermal management and structural considerations. The permanent magnet topology has a more limited operating temperature but simpler power electronics and control system than the switched reluctance topology. The very high speeds associated with CO<sub>2</sub> at megawatt scale favors the use of He-Xe, but CO<sub>2</sub> has better dielectric and thermal properties for high voltage alternator coil protection.

### III.B.1. Permanent Magnet Alternator Option

The permanent magnet topology is typically the best choice if the compressor inlet temperature is below 500 K as highlighted in Table II. Permanent magnet remanence, epoxy and insulation lifetime, and thermal conductance all decrease with temperature. High specific power permanent magnet alternators, as shown in Figure 9, create high internal heat flux that must be dissipated from the coils.

### III.B.2. Switched Reluctance Alternator

The switched reluctance alternator shown in Figure 10 is an alternative alternator topology made possible by recent power electronics development. It replaces the rotating magnet with an iron alloy for a much simpler and robust system that can operate at higher temperatures and speeds. It does not require epoxy and ceramic coil insulation can be used due to the simpler coil geometry. This option is attractive with the CO<sub>2</sub> and SO<sub>2</sub> working fluid options because it can support higher rotational speeds and operating temperatures, but it requires more complex high voltage rad-hardened power electronics that may take several years to develop and both fluids are potentially corrosive.

Higher voltage transmission could result in lower mass power distribution due to the reduced current requirements. For state-of-the-art silicon components used in the alternator controller drive, the low (350 K) operating temperature

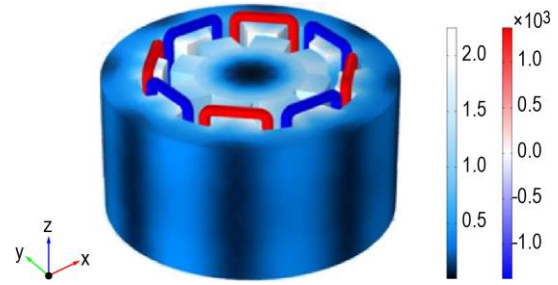

Fig. 9. Permanent magnet topology (500 K limit)

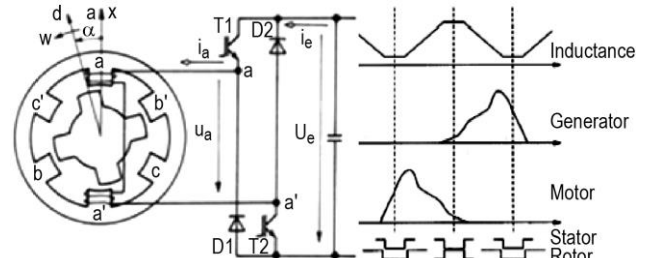

Fig. 10. Switched reluctance topology (700 K limit)

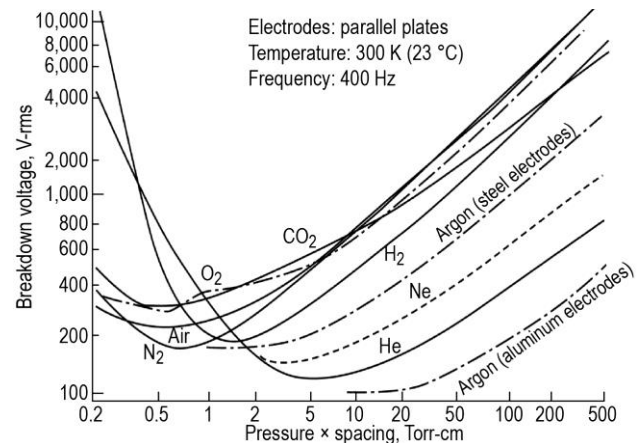
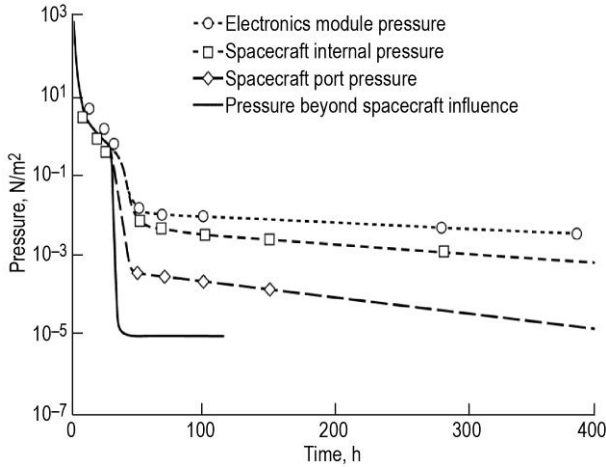

Fig. 11. Breakdown voltage comparison of several gases (Ref. 17)

for these electronics implies large area requirements for heat rejection and do not currently support 1 kV operation in space due to the combined effects of radiation and Paschen voltage limits shown in Figure 11.

High voltage (~1 kV) is required to maintain reasonable powertrain mass and Joule heating losses (i.e., system alpha below 20 kg/kWe), but the Xe working fluid is a conductor, and CO<sub>2</sub> clearly has better dielectric properties than He and Xe. As shown in Figure 12 the pressure around the high voltage coils and controller is likely to be persistent for some time due to trapped gases and outgassing despite being in the vacuum of space This suggests high voltage partial discharge will be a risk associated with a high voltage Brayton alternator. So interestingly, it appears the use of supercritical Xe-He as the Brayton working fluid with supercritical CO<sub>2</sub> as the alternator coolant fluid might be an attractive solution.



**Fig. 12.** Space internal pressure persistence (Ref. 17)

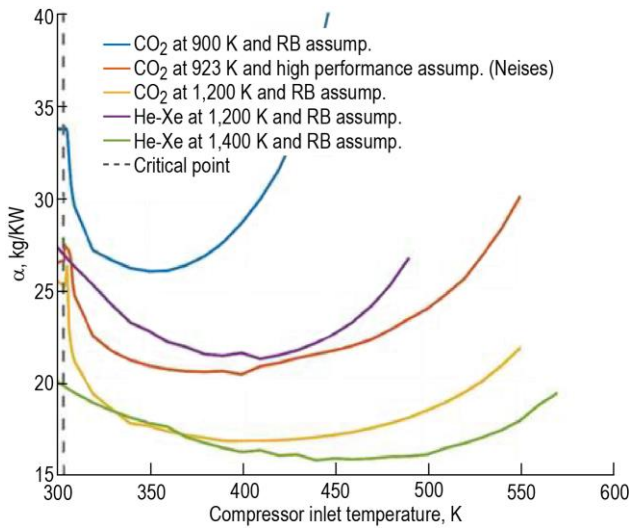

**Fig. 13.** Impact of working fluid on NEP system alpha (Ref. 18)

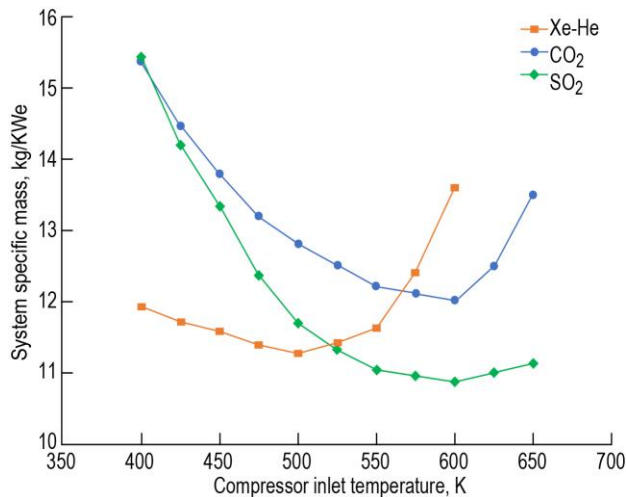

**Fig. 14.** Impact of working fluid on NEP system alpha at 1200 K TIT and 10 MPa (Creare (Ref. 19) with permission)

### III.C. Working Fluid Selection

As discussed in the previous Brayton engine and alternator sections of this report, the working fluid not only determines the optimal PCU component architecture and associated development risk posture, but also the entire NEP vehicle system alpha as shown in Figure 13 (Ref. 20).

Note that these results are similar to the MTAS study conclusions (Ref. 2) in that the supercritical CO<sub>2</sub> optimizes at a lower system alpha at 1200 K compared to low pressure He-Xe. But in those studies, the He-Xe working fluid was assumed to be low pressure and to have a higher proportion of He in the binary mixture. A more recent study by Creare (Ref. 19) increased both the pressure and Xe proportion in the binary working fluid. The results shown in Figure 14 compared three working fluids and complements the work shown in Figure 13.

Note that if the optimized Xe-He Brayton system is used the ideal compressor inlet temperature is 500 K and can use the permanent magnet alternator. But the optimization points for the CO<sub>2</sub> and SO<sub>2</sub> compressor inlet temperature is at 600 K and would potentially require using the switched reluctance alternator to support the higher rotational speeds and temperatures. In addition, both electromagnetic interference and radiation tolerance are required (Ref. 17). Since the switched reluctance alternator topology more heavily relies on advanced power electronics, this favors the use of Xe-He mixture working fluid at 500 K inlet temperature that is compatible with a permanent magnet synchronous alternator.

The thermodynamic properties of the working fluids are critical to the proper functioning of the turbomachinery and recuperator. For example, as shown in Figure 15, supercritical CO<sub>2</sub> has extremely nonlinear properties near the critical point. This feature significantly reduces the compressor work when it can operate near this point, but it also adds risk to the flow stability of the compressor if the temperature changes slightly as shown in Figure 16. If the compressor stalls or surges, an abrupt power change or shutdown of the PCU can result.

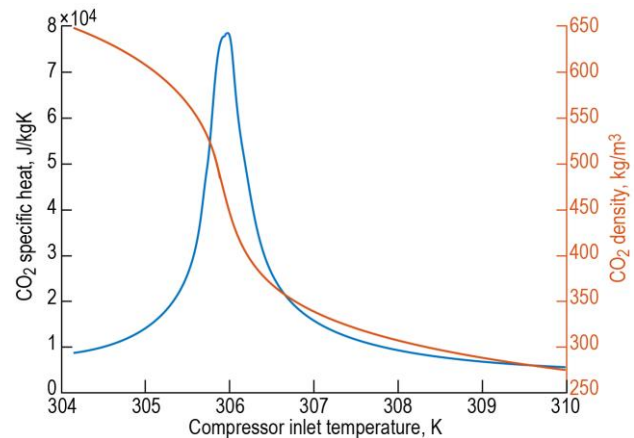

**Fig. 15.** Nonlinear CO<sub>2</sub> fluid properties (Ref. 13)

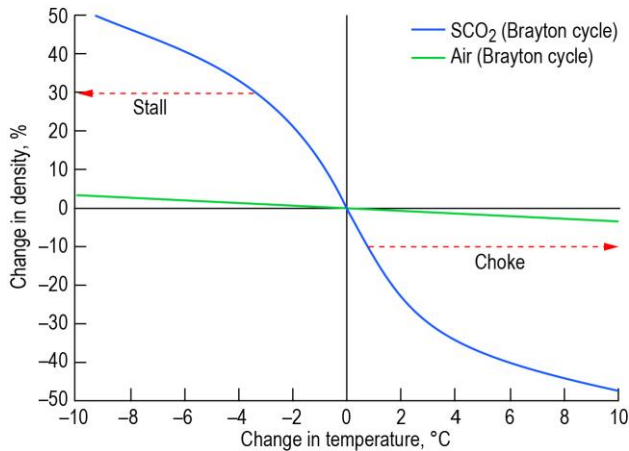

**Fig. 16.** Compressor flow instability (Refs. 21-22)

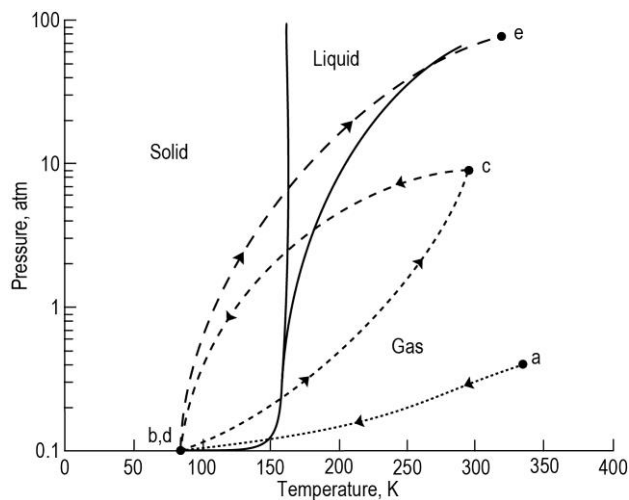
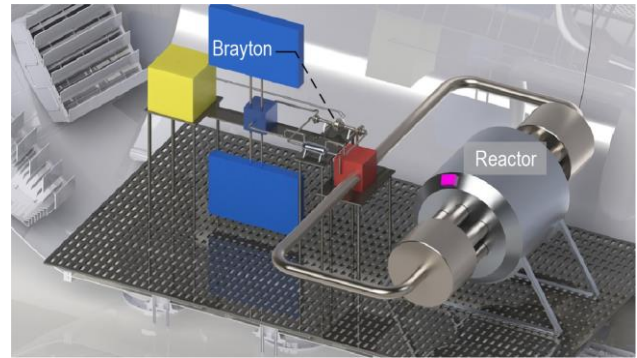

**Fig. 17.** Phase Diagram of Xe with Freezing point

One additional concern with the Xe-He Brayton fluid is the potential of a heavy noble gas such as Xe freezing during system shutdown if the sink temperature goes below 160 K as shown in Figure 17. If Xe is substituted with Ar or Kr, this could be mitigated as the system shutdown temperature would then become 83.75 and 115.75 K, respectively.

A pure He working fluid could be used if necessary to avoid freezing concerns. However, it would require a two-stage axial turbomachinery system (Ref. 23) due to the lower molecular weight instead of the simpler single-stage radial turbomachinery that was used in BRU shown in Figure 3. For this reason, transient start-up testing in a cold soaked thermal-vacuum environment with expected spacecraft solar insolation angles is critical to establishing startup reliability and working fluid compatibility.

As shown in Figure 18, the 500 kW<sub>e</sub> supercritical Xe-He Brayton power conversion unit is only ~2 ft in length and 6 in. in diameter making it comparable in size to the supercritical CO<sub>2</sub> working fluid alternative option.



**Fig. 18.** Microreactor with 500 kW<sub>e</sub> Brayton Relative Size

In addition, prior space He-Xe Brayton engine and cryocooler testing has demonstrated 38,000-h and over 5-year operation respectively with no degradation of the moving parts (Refs. 8 and 24).

## VII. Conclusions

Selecting the optimal inlet temperatures, working-fluid, and pressure for the Brayton engine and embedded alternator are key design challenges that must be addressed early in this technology maturation effort. For supercritical CO<sub>2</sub> and supercritical SO<sub>2</sub>, the ideal compressor inlet temperature is estimated to be 600 K, and for supercritical Xe-He it is estimated to be 500 K under the assumptions used in this study. Overall, our findings indicate supercritical SO<sub>2</sub> can provide the lowest specific mass, supercritical Xe-He is only slightly higher (3% greater than SO<sub>2</sub>), and CO<sub>2</sub> has the highest specific mass (11% greater than SO<sub>2</sub>). Although SO<sub>2</sub> has the lowest specific mass, it is also the least mature option for use in a closed-loop Brayton converter. Corrosion and long-term fluid stability are potential challenges that would need to be studied, like investigations presently underway for supercritical CO<sub>2</sub>. These factors may ultimately require more exotic materials for SO<sub>2</sub> and/or limit the turbine inlet temperature below values achievable with Xe-He. Conversely, Xe-He is an inert gas mixture that is not susceptible to corrosion or fluid degradation, and it has already demonstrated long-term operation in closed-loop Brayton converters developed for space-flight.

Although system  $\alpha$  with Xe-He is slightly greater than it is with SO<sub>2</sub> and under certain assumptions, CO<sub>2</sub>, it is recommended that near term efforts focus on a Xe-He inert working fluid to limit both the development effort and to avoid uncertainties that may create future limitations. This includes determining optimal Xe-He binary mixture proportion, pressure, temperature, and number of turbine stages for the best technical and risk posture. However, it is acknowledged that there are no current closed Brayton Xe-He industrial efforts aside from the small studies supported by NASA and this will require additional government investment to develop it to TRL 5.

## Acknowledgments

This work was supported by NASA's Space Technology Mission Directorate (STMD) through the Space Nuclear Propulsion (SNP) project. We also acknowledge Creare, Brayton Engines, Raytheon, Kurt Polzin, Marc Gibson, Max Chaiken, Wayne Wong, Scott Wilson, Sal Oriti, Max Yang and Paul Schmitz for their many helpful discussions and insights.

## References

1. Polzin, K., Curran, F., Rodriguez, M., "Nuclear Electric Propulsion-Technology Maturation Plans," July 2021
2. Mason, L., Oleson, S., Schmitz, P., et al., "Nuclear Power Concepts for High-Power Electric Propulsion Missions to Mars," NETS April 2021
3. Oleson, S., Burke, L., Mason, L., et al., "Compass Final Report: Nuclear Electric Propulsion (NEP)-Chemical Vehicle 1.2," Sept. 2021
4. A Consensus Study Report of the National Academies of Sciences, Engineering and Medicine, Space Nuclear Power for Human Mars Exploitation, February 2021.
5. "Independent Assessment of the Technical Maturity of Nuclear Electric Propulsion (NEP) and Nuclear Thermal Propulsion (NTP) Systems," NASA Engineering & Safety Center, June 2020.
6. SNP Technology Interchange Meetings (TIM), 2020-2021. NASA Technology Memorandum in progress, notes for individual TIMs available through the Space Nuclear Propulsion project, NASA-MSFC.
7. Lee S. Mason, Dynamic Energy Conversion: Vital Technology for Space Nuclear Power, Journal of Aerospace Engineering, Vol. 26, 2014
8. J.E. Davis, "Design and Fabrication of the Brayton Rotating Unit," 1972.
9. Vernon, R.W. and Miller, T.J., "Experimental performance of a 2–15-kilowatt Brayton power system using a mixture of helium and xenon," NASA TM-X-52936, 1970
10. Howard, S.A. et al., "Gas Foil Bearing Technology Advancements for Closed Brayton Cycle Turbines," NASA/TM—2007-214470, Glenn Research Center, Cleveland, OH, 2007.
11. <https://www.specialmetals.com/documents/technical-bulletins/nimonic-alloy-90.pdf>
12. Wright, S., et al., "Operation and Analysis of a Supercritical CO<sub>2</sub> Brayton Cycle," SAND2010-0171, 2010.
13. Analytical Mechanics Associates, "NEP Power Conversion Cycle Helium-Xenon and CO<sub>2</sub> Working Fluids Comparison," 2021.
14. Machemer, W., Duchek, M., et al., "Mass Modeling of NEP Power Conversion Concepts for Human Mars Exploration" NETS 2022
15. Dostal, V., Driscoll, M., Hejzlar, P., "A Supercritical Carbon Dioxide Cycle for Next Generation Nuclear Reactors," MIT-ANP-TR-100, 2004
16. Wright, S., et al., "Initial Status and Testing of a Supercritical CO<sub>2</sub> Brayton Cycle Test Loop," Proceedings of the International Congress on Advances in Nuclear Power Plants (ICAPP), Anaheim, CA, 2008.
17. NASA Handbook 4007, "Spacecraft High-Voltage Paschen And Corona Design Handbook," 2016
18. Harnack, C., Duchek, M., et al., "Closed Brayton Cycle Modeling for an NEP Power Conversion Application," NETS 2022
19. Duchek, M., et al., "Sensitivity of Hybrid NEP-Chemical Vehicle Mass to Assumptions for Crewed Opposition-Class Mars Missions" AIAA Propulsion & Energy Forum, 2021.
20. Breedlove, J., "Supercritical Brayton Converter for Nuclear Electric Propulsion," SBIR Phase I, 2021 [Used with permission]
21. Rosseau, I., "Analysis of a High Temperature Supercritical Brayton Cycle for Space Exploration," MIT Research Science Institute, 2007.
22. Wright, S., "Supercritical Brayton Cycle Nuclear Power System Concepts," AIP Conference Proceedings, Vol 880, Issue 597, 2007
23. A.J. Juhasz, "Heat transfer analysis of a closed Brayton cycle space radiator," Collect. Tech. Pap. - 5th Int. Energy Convers. Eng. Conf., vol. 2, no. October, pp. 1216–1226, 2007.
24. Swift, W.L., Dolan, F.X., and Zagarola, M.V., "The NICMOS Cooling System – 5 Years of Successful On-Orbit Operation," Transactions of the Cryogenic Engineering Conference-CEC, Vol. 52, AIP Conference Proceedings, Vol. 985, 2008, pp. 799–806.