

Herding Schrödinger's Cats: A NASA Perspective of Quantum Computing



Dr. Rupak Biswas

Director, Exploration Technology Directorate

NASA Ames Research Center
Moffett Field, Calif., USA

*33rd Parallel CFD International Conference
Alba, Italy, 25 – 27 May 2022*



Introduction to Quantum Physics



“If you think you understand quantum mechanics, you don’t understand quantum mechanics”

- Richard Feynman



“Do you really believe the moon isn’t there when nobody looks?”

“God doesn’t play dice”

- Albert Einstein

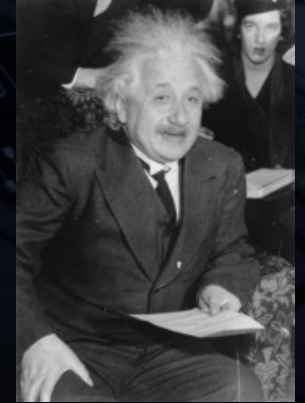

- Quantum operations occur on a very small (atoms, photons) system
- Outcome of quantum operations is often probabilistic, associated with how measurement is done
- “Schrödinger’s Cat” is a thought experiment in quantum mechanics
- Quantum technologies can be used for various purposes: Communication, Networks, Sensors, Cybersecurity, etc.

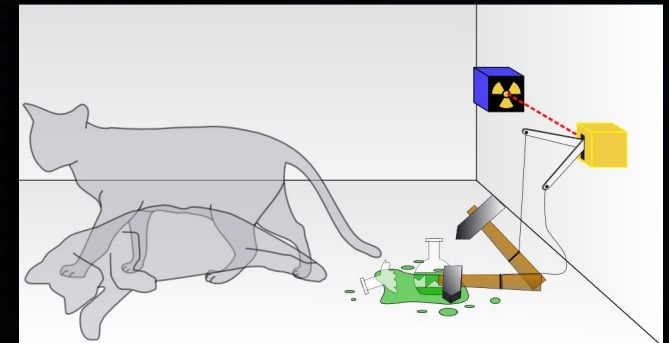

This being the Parallel CFD conference, focus is on quantum computing

Birth of Quantum Computing

- Babbage's Analytical Engine (in 1837) was a classical mechanical machine (general-purpose computer)
- Turing Machine (abstraction that underlies universal computing) firmly rooted in classical mechanics
- Abstraction led to forgetting that how fast one can compute depends on the fundamental properties of nature
- Feynman and Manin recognized (in 1982) that certain quantum phenomena could not be simulated efficiently by a classical supercomputer
- Wondered whether such quantum effects could be used to speed up general computations
- Researchers began to examine how different models of physics affect how fast we can compute
- Peter Shor (in 1994) devised polynomial-time quantum algorithm for integer factorization
- Subsequent breakthroughs occurred in quantum error correction (initially thought to be impossible)

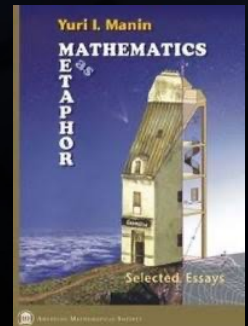
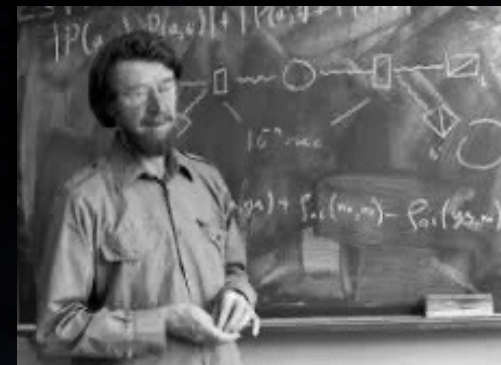
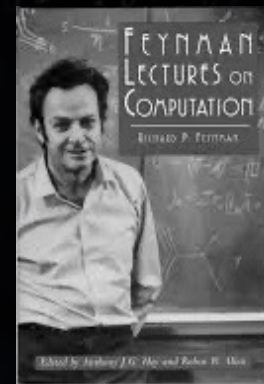
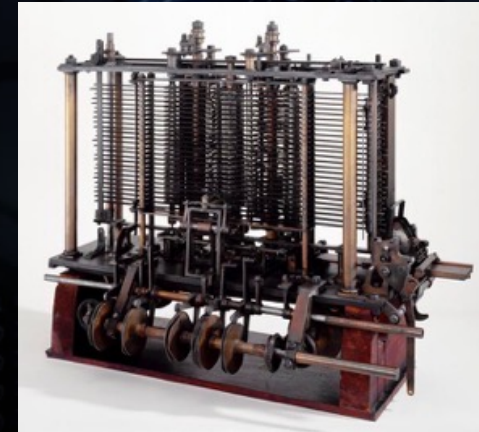

Computational Complexity

➤ Classical Supercomputing

- Current world's fastest (per TOP500 list): Fugaku (RIKEN, Japan) sustained 442 Pflop/s on LINPACK
- International push to Eflop/s: 1×10^{18} multiplications per second

➤ Difference between Polynomial and Exponential (compare N^2 and 2^N)

- If $N = 10$, $N^2 = 100$ but $2^N = 1024$
- If $N = 100$, $N^2 = 10,000$ but $2^N = 10^{30}$
- If $N = 512$, $N^2 = \sim 262,000$ but $2^N = 10^{153}$
(# of atoms in the universe $\sim 10^{78}$)

➤ An Exaflop/s supercomputer will require 10^{118} billion years to solve a binary optimization application (e.g., Traveling Salesman Problem) with 512 variables

- Age of universe only ~ 14 billion years

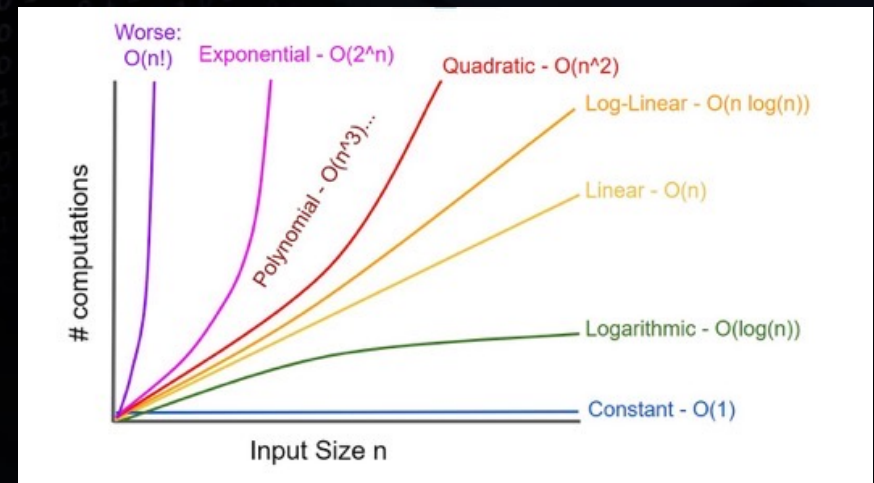

Basics of Quantum Computing

- Quantum mechanics deals with physical phenomena at very small scales (~100nm) where actions are quantized
- Outcome of a quantum experiment often probabilistic, and associated both with what was done before the measurement and how the measurement was conducted
- Qubits (quantum bits) can exist in a superposition of states, allowing N qubits to represent 2^N states simultaneously
- A quantum algorithm applies quantum operations on the 2^N states
- At the end of a computation, on measurement, the system collapses to a classical state and returns only one bit string as a possible solution

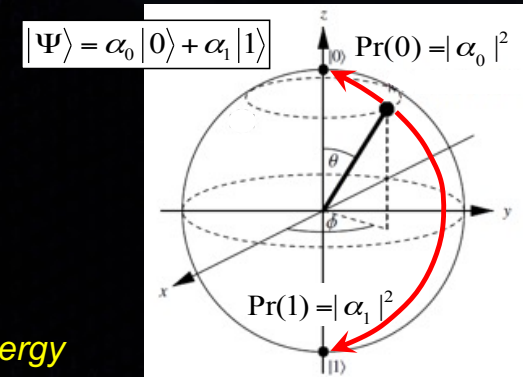
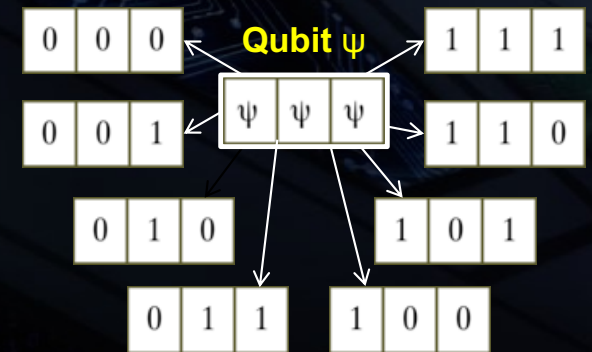

QC vs. HPC for a hardware benchmarking computation (in 2019)

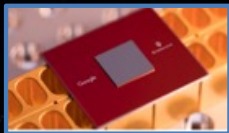

Google's 72-qubit Bristlecone chip



NASA's Electra supercomputer

- 2 secs vs. 59 hours
- 0.4 KWh vs. 97 MWh
- 5 orders less time and energy

B. Villalonga *et al.* (2020), Establishing the quantum supremacy frontier with a 281 Pflop/s simulation, *Quantum Sci. Technol.* **5**, 034003

Uniqueness of Quantum Physics

Superposition

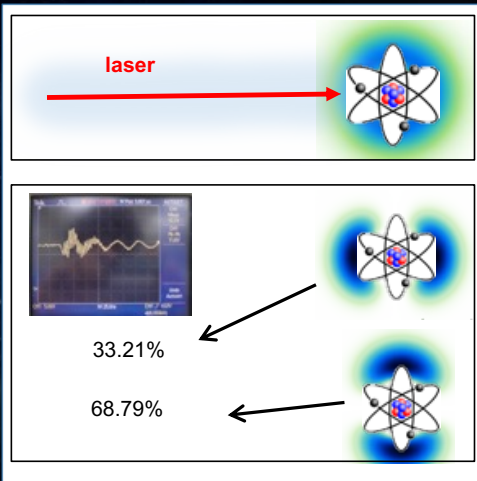

Experiment's outcome depends probabilistically on measurement

Tunneling

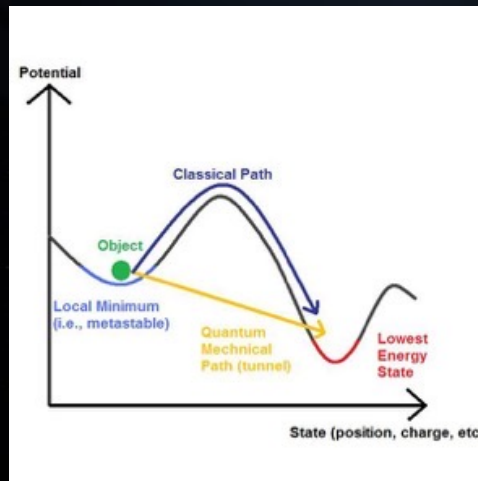

Wave-Particle duality allows going through "barriers"

Entanglement

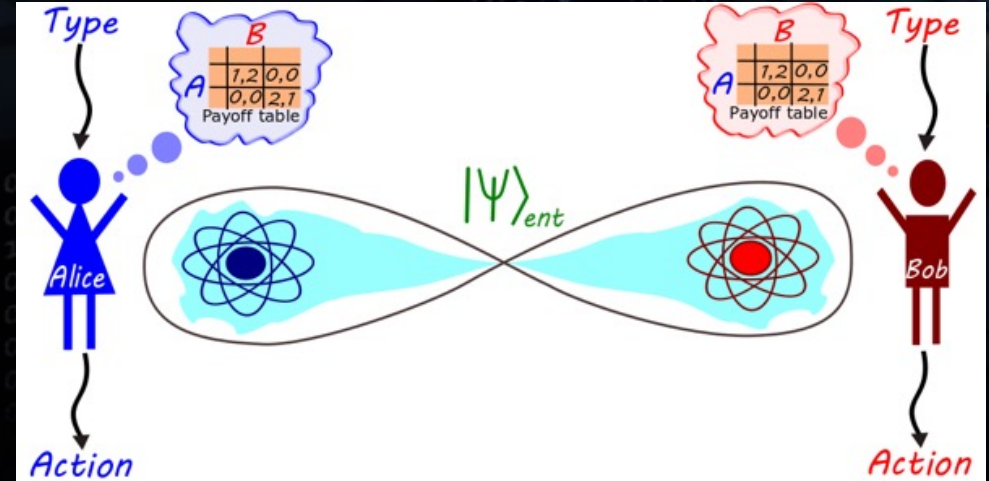

Intrinsically correlated "spooky action at a distance"

Numerous laboratory experiments have confirmed these quantum phenomena
Challenge is to harness these unique features at scale to find "better" solutions to problems

The Quantum Revolution



NATIONAL STRATEGIC OVERVIEW FOR QUANTUM INFORMATION SCIENCE

Product of the
SUBCOMMITTEE ON QUANTUM INFORMATION SCIENCE
under the
COMMITTEE ON SCIENCE
of the
NATIONAL SCIENCE & TECHNOLOGY COUNCIL
SEPTEMBER 2018

Quantum Information Science (QIS): the next technological revolution

- *“Quantum information science—including concepts and technology that support revolutionary advances in computing, communications, and metrology—arises from a synthesis of quantum mechanics and information theory”*
- *“new applications and platforms will likely come from protocols and approaches that are not yet invented”*
- *“the quantum revolution may affect agency mission spaces and how agencies can nurture the adoption of quantum technologies within the Federal Government by cultivating potential end-user application”*

National Quantum Initiative Act signed on Dec 21, 2018 (Public Law 115-368)

Recent Advances in Quantum Algorithms for CFD

Plasma simulations

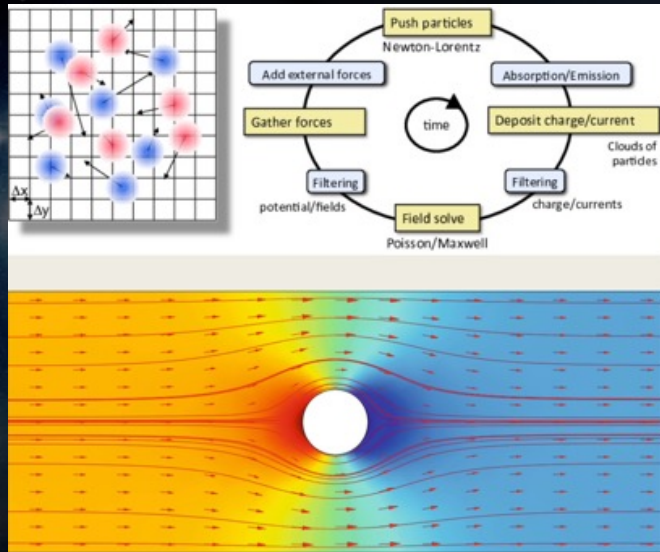

- Computationally intensive since inherently nonlinear
- State-of-the-art classical algorithms (e.g., Particle-in-Cell) require many processors and energy
- Goal is to design quantum algorithms (for fault-tolerant quantum computers) that can provide speed-up over classical algorithms

Fluid Dynamics

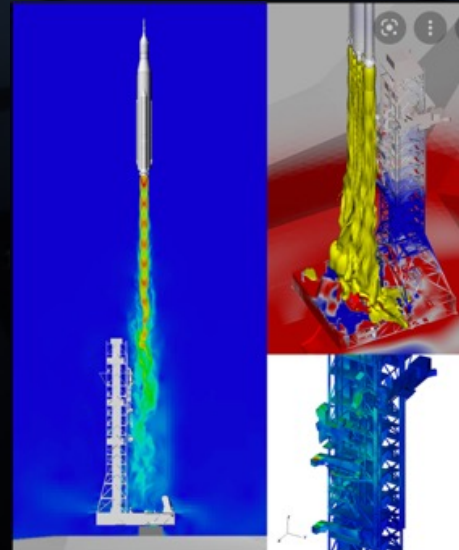

- Models governed by both ordinary and partial differential equations arise extensively in natural and social sciences, medicine, and engineering
- Express differential equations with nonlinearities with quadratic polynomials – this includes many archetypal models in biology, fluid dynamics, and plasma physics

J.-P. Liu *et al.* (2021), Efficient quantum algorithms for dissipative nonlinear differential equations, *Proc. Natl. Academy of Sciences*, **118**

H. Krovi (2022), Improved quantum algorithms for linear and nonlinear differential equations, *arXiv:2202.01054*

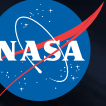

NASA Overview: Mission Directorates

Vision: *To discover and expand knowledge for the benefit of humanity*

Aeronautics Research



Transform aviation through innovative R&D

Space Operations



Launch and space operations

Exploration Systems



Moon to Mars deep space exploration

Science

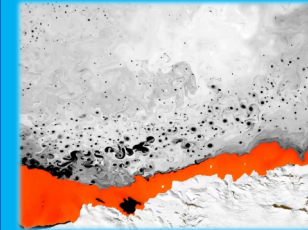

Understand the Sun, Earth, and Universe

Space Technology



Pursue, develop, infuse transformational tech

NASA Overview: Centers & Facilities

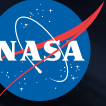

Ames Research Center



Armstrong Flight Research Center



Jet Propulsion Laboratory



Johnson Space Center



Glenn Research Center

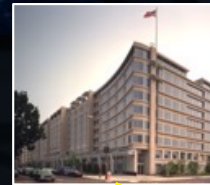

Headquarters



Goddard Space Flight Center



Langley Research Center



Marshall Space Flight Center



Kennedy Space Center



Stennis Space Center

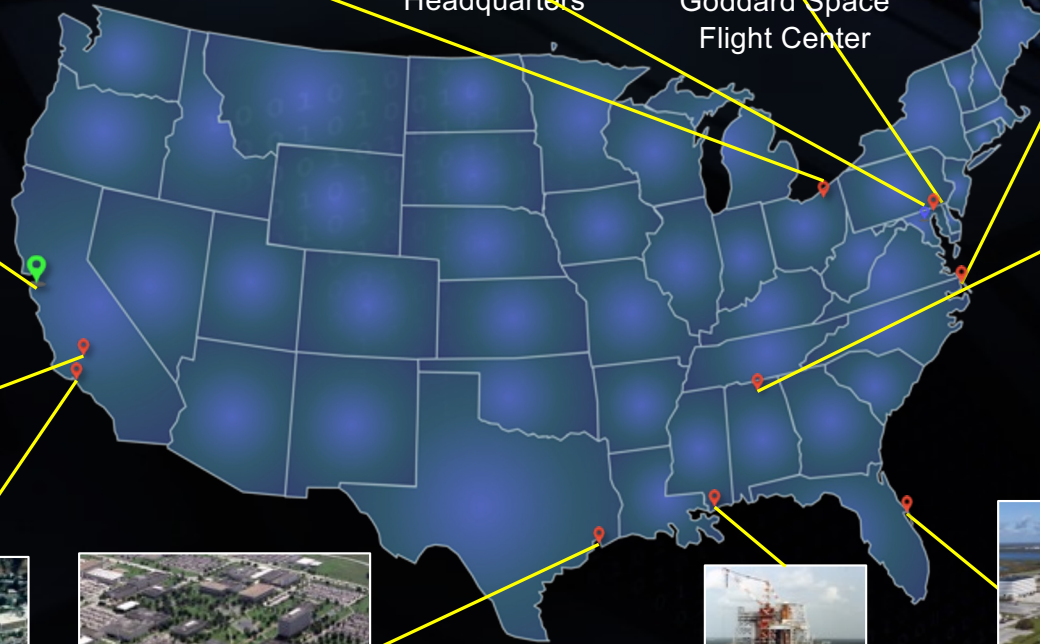



Need for Advanced Computing

Enables modeling, simulation, analysis, and decision-making

- Digital experiments and physical experiments are tradable
- Physical systems and live tests generally expensive & dangerous (e.g., extreme environments), require long wait times, and offer limited sensor data
- NASA collects and curates vast amounts of observational data that require extensive analysis and innovative analytics to advance our understanding

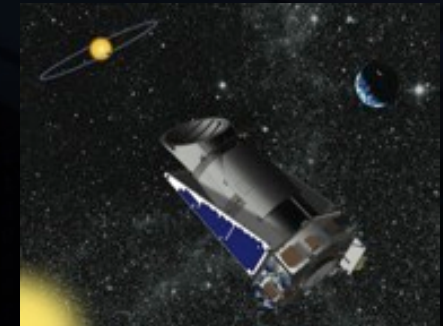

- Decades of exponentially advancing computing technology has enabled dramatic improvements in cost, speed, and accuracy – in addition to providing a predictive capability
- Many problems pose extremely difficult combinatorial optimization challenges that can only be solved accurately using advanced technologies such as quantum computing
- NASA's goals in aeronautics, earth & space sciences, and human & robotic exploration need major increase in computing capability to enhance accuracy, reduce cost, mitigate risk, accelerate R&D & heighten societal impact



Advanced Computing Environment



Cloud Computing



Accelerator Technologies

SUPERCOMPUTING

Data Portals



Visualization, Data Analytics & Machine Learning



Disruptive Technologies (Quantum, ...)



Space Vehicle Launch Environment

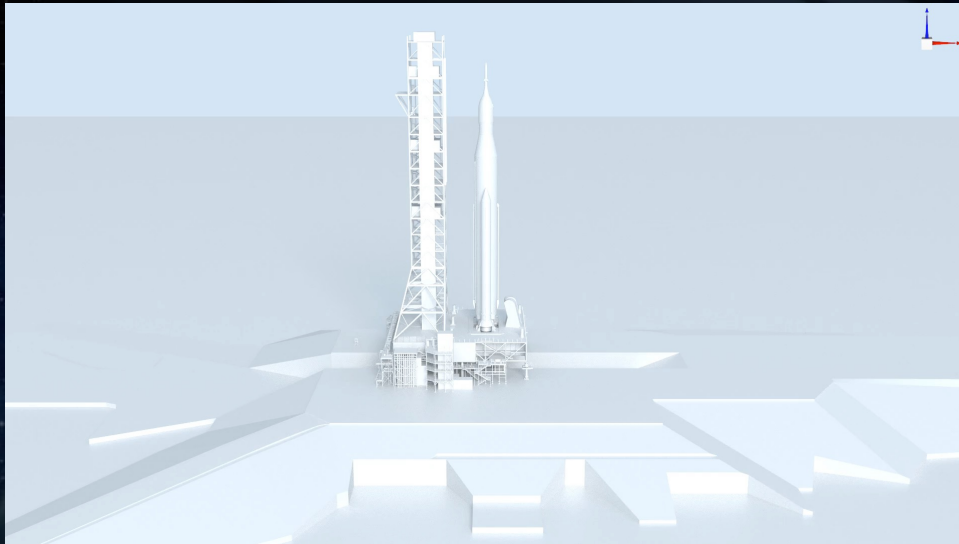

Visualization of launch environment geometry used in LAVA Cartesian simulation

Temperature cutting plane passing through an SRB centerline (green people shown for scale)



SRB Separation from SLS

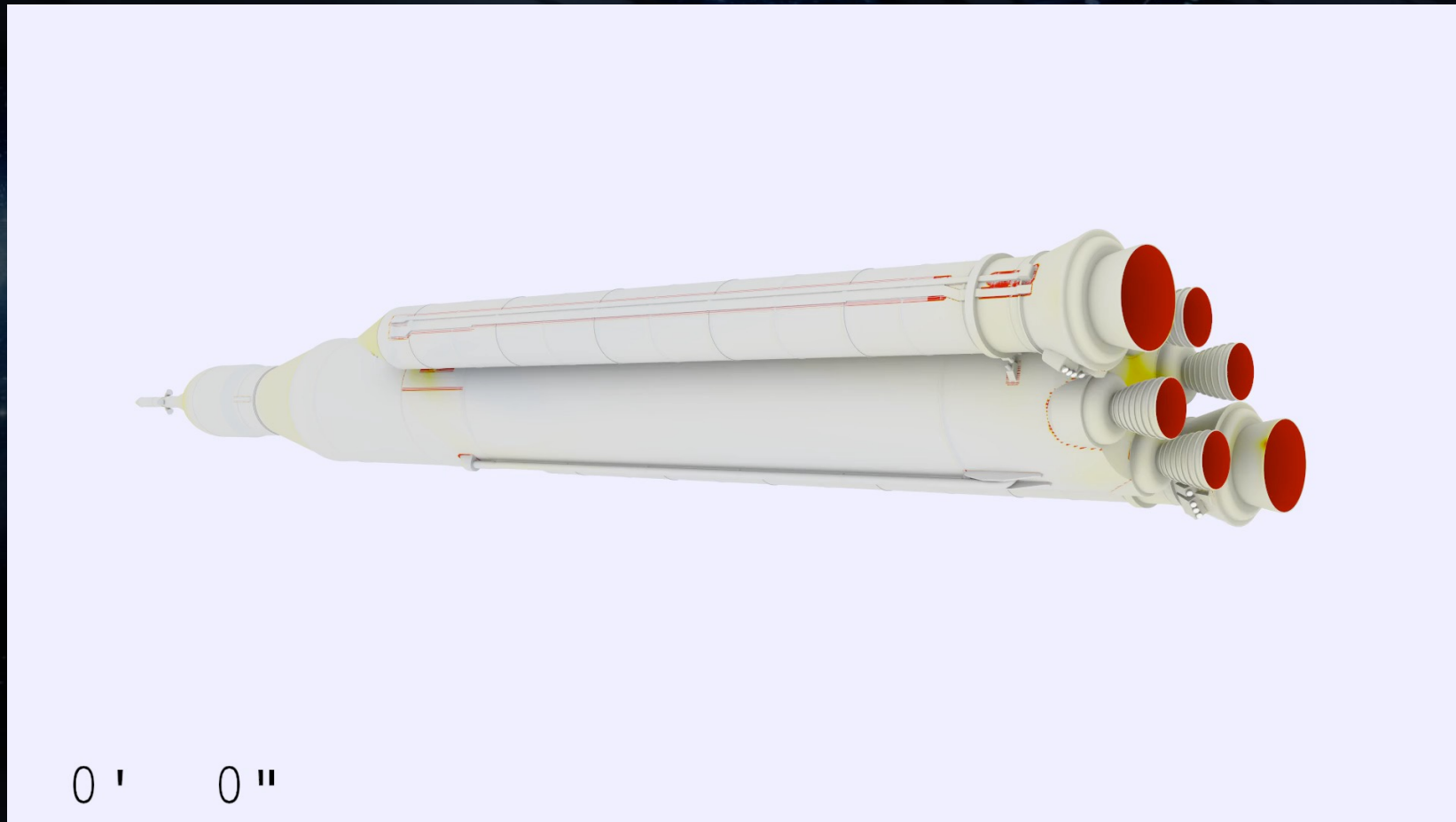

Stage separation at Mach 4 (particles colored by age)

Orion Launch Abort System

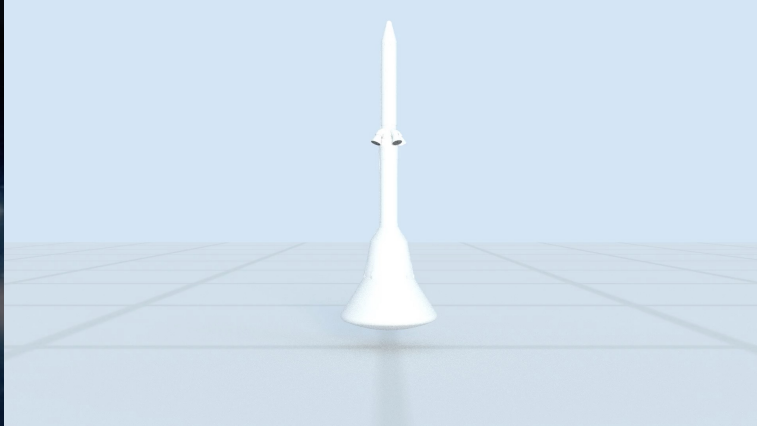

Particles seeded at nozzle colored by velocity magnitude (white = fast, dark orange = slow) for pad abort test



Plume temperature (white = high, black = low) during ascent abort at transonic speed with high angle of attack



Turbulent structures resolved in plumes colored by gauge pressure during ascent abort at transonic speed

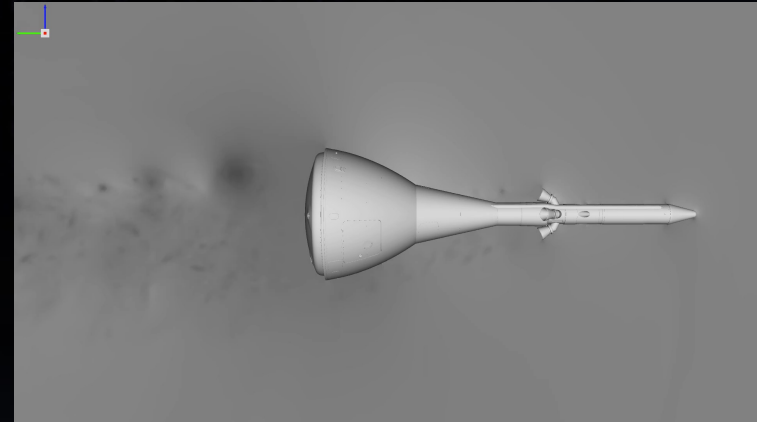

Pressure on vertical plane (white = high, black = low) during ascent abort at transonic speed with high angle of attack

Low Density Supersonic Decelerator

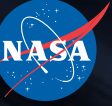

*Flow over parachute in supersonic regime
(particles colored by vorticity)*

*Mach number contours on cut plane
through center of domain*

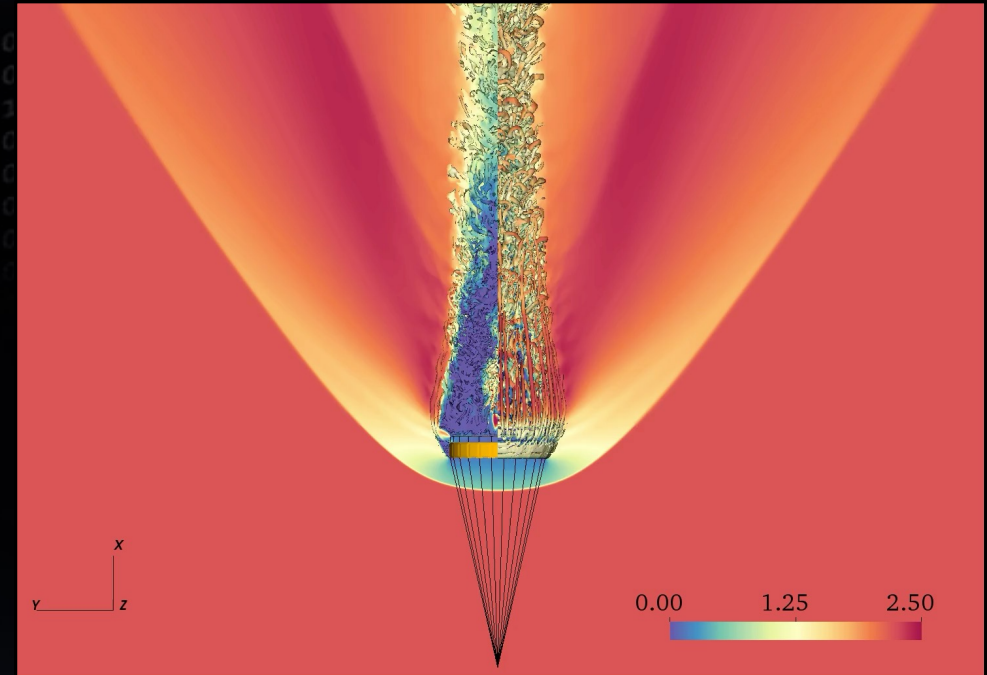

Supersonic Boom and Jet Noise

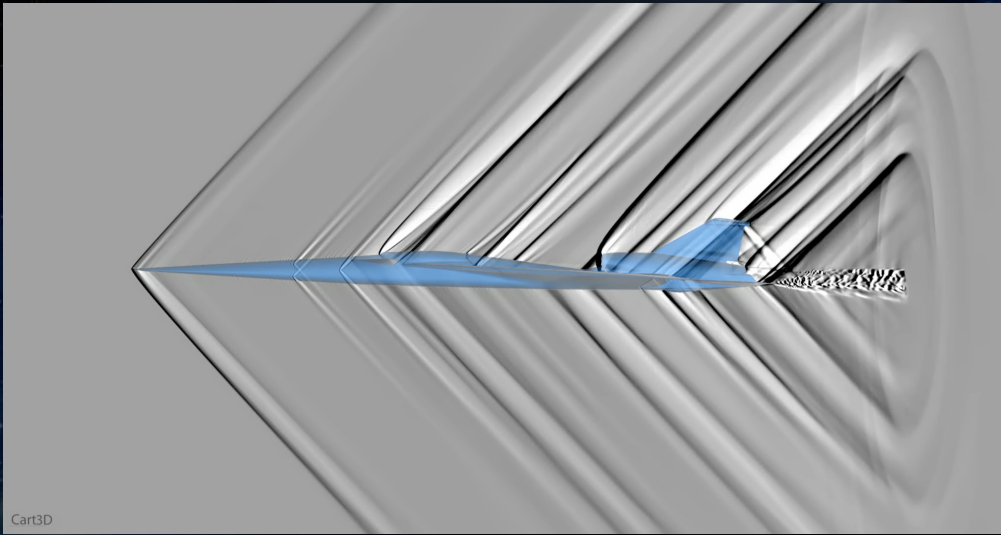

Cart3D

Low Boom Flight Demonstrator (X-59)
numerical schlieren of sonic boom signature

*Iso-contour of Q-criterion colored by
vorticity magnitude and velocity on surface*

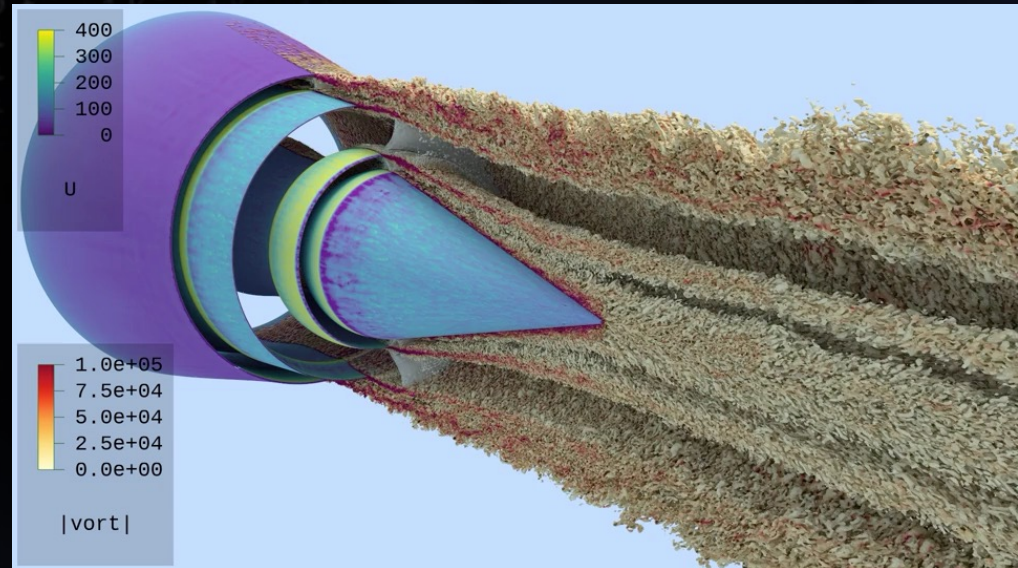

Aircraft Landing Gear Noise

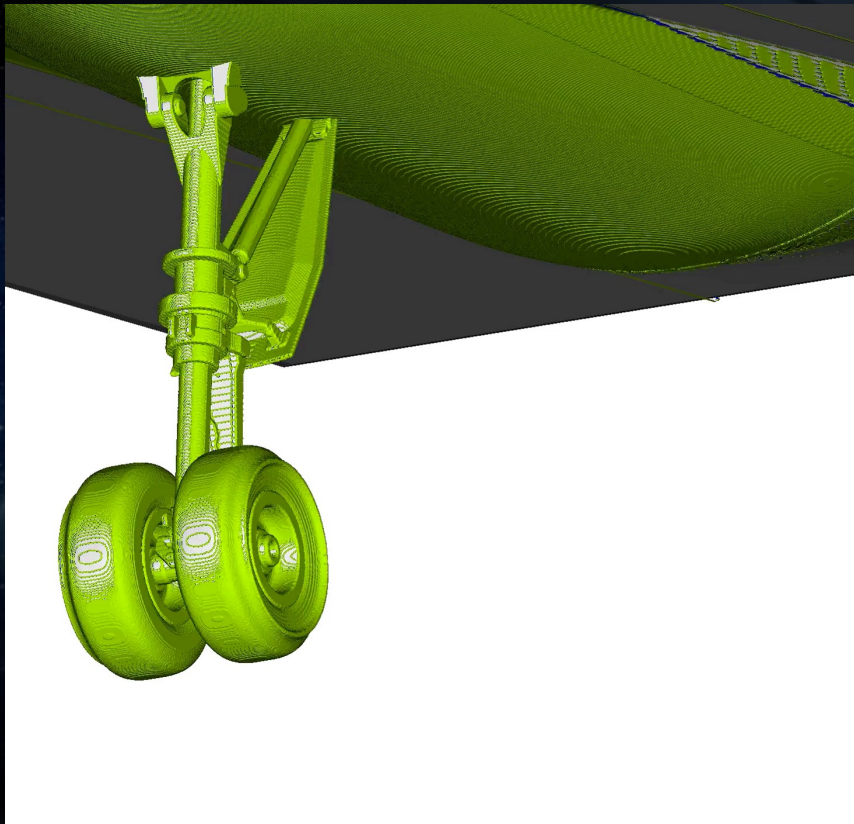

Simulation using 12 levels of mesh refinement and 1.6 billion cells (iso-contours of vorticity colored by Mach number: blue = 0, red = 0.25)

Centerline slices showing velocity magnitude

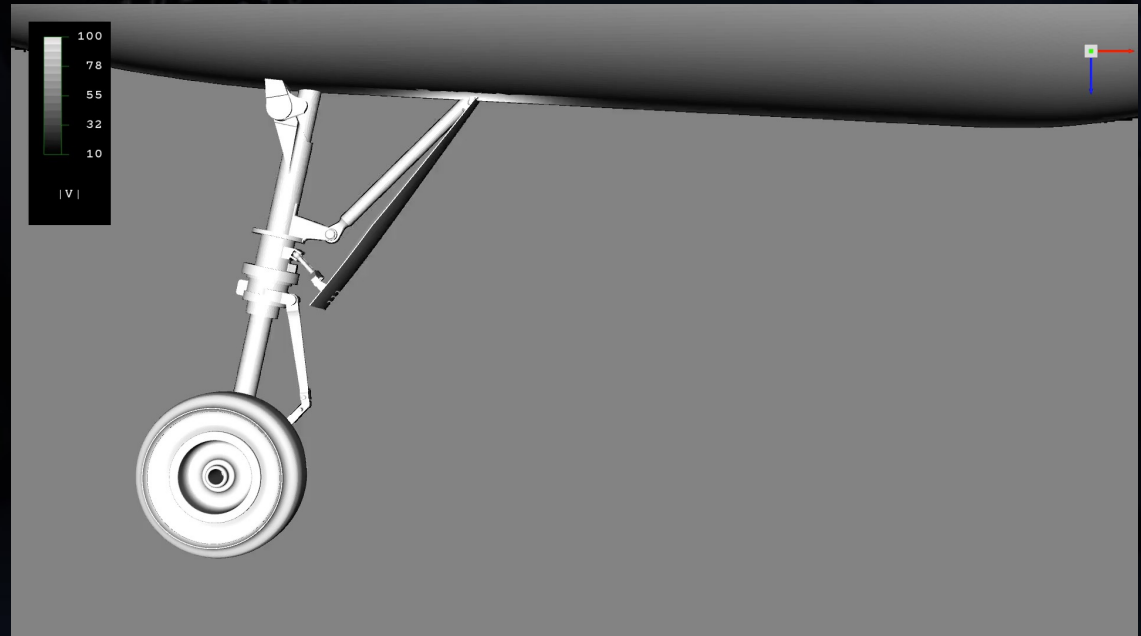

Air Mobility Concept Vehicles

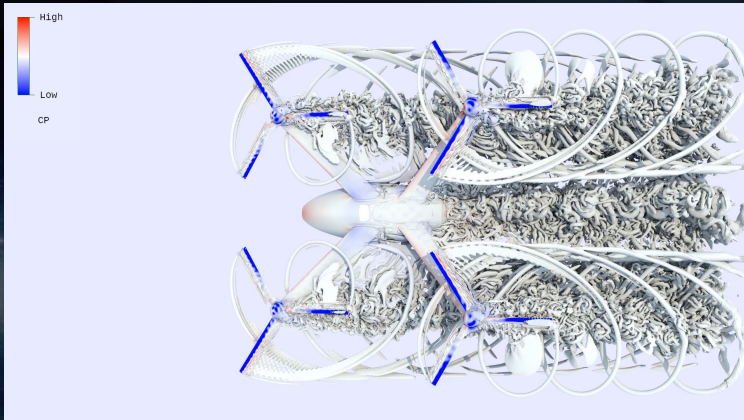

Vertically-separated rotors to reduce drag

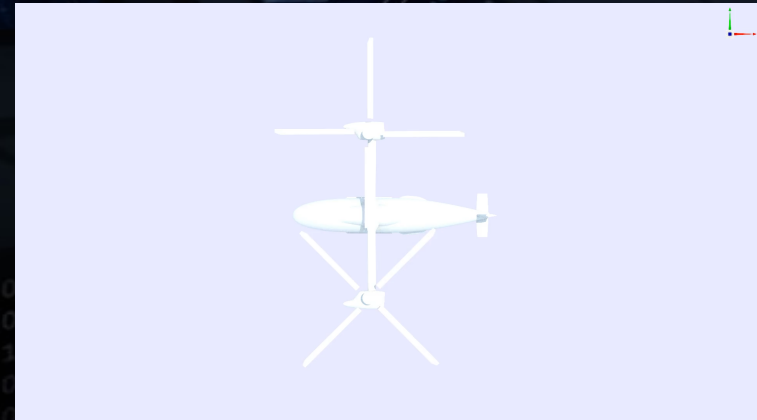

Inter-meshing rotors to increase efficiency

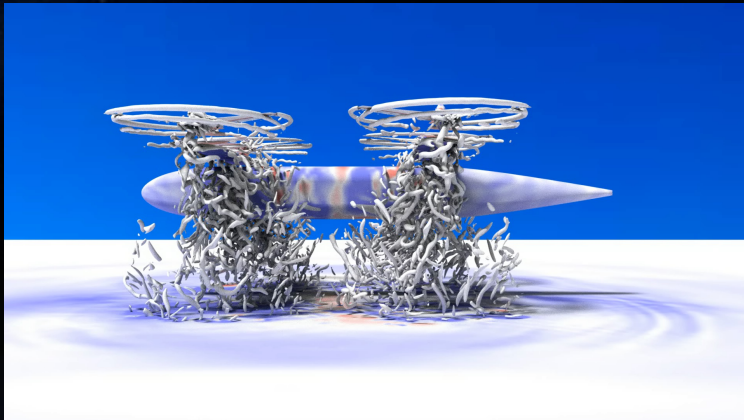

Quad tilt rotor

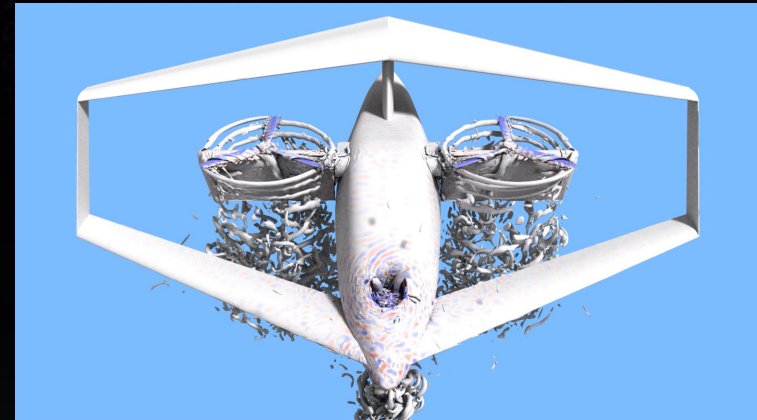

Joined wing to minimize induced drag

Global Ocean Modeling

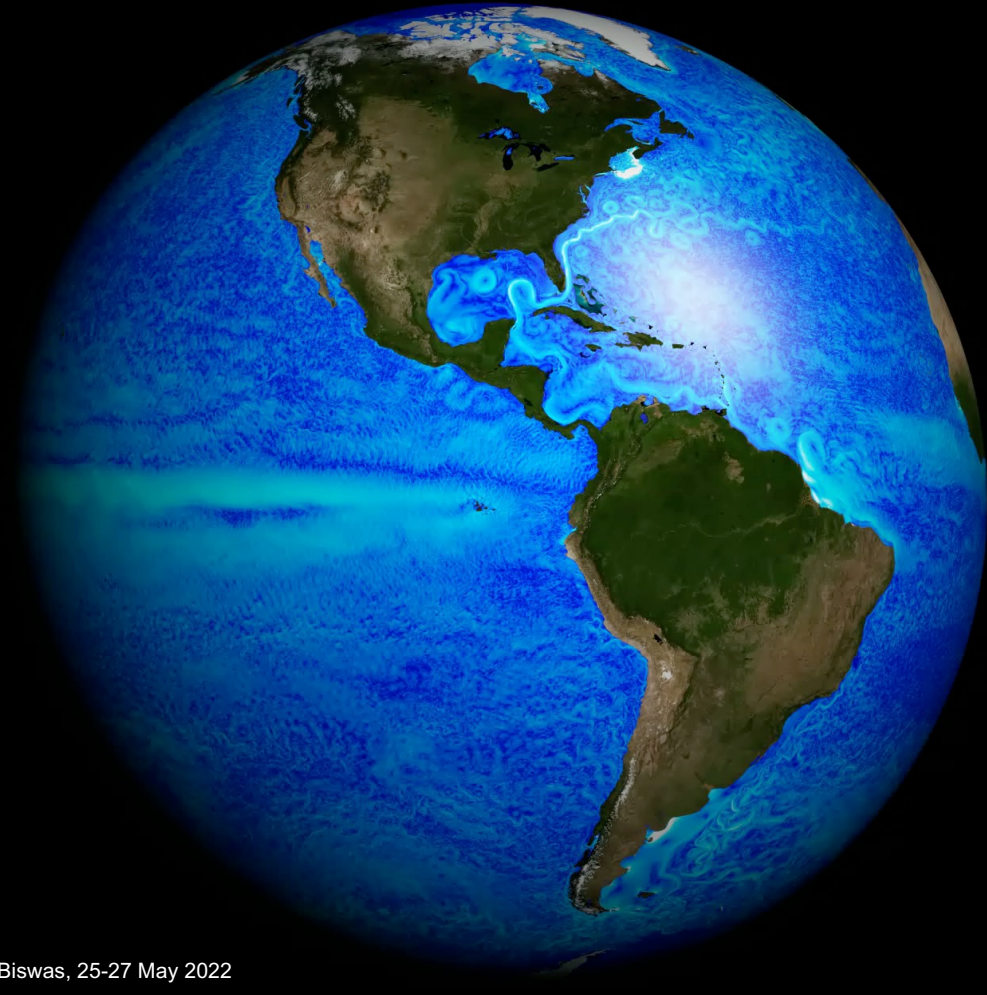
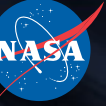

Biswas, 25-27 May 2022



Other Computational Challenges for NASA



Quantum ML
for Earth
Science Data
Analysis

Superposition



$$\psi_{\text{cat}} = \frac{1}{\sqrt{2}}(\psi_{\text{alive}} + \psi_{\text{dead}})$$

Resource Allocation
and Scheduling for
Space Exploration

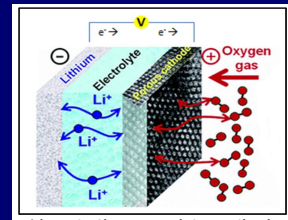
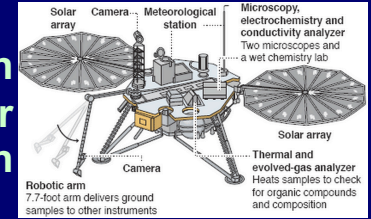

Quantum
Simulations for
Aerospace Materials

Tunneling

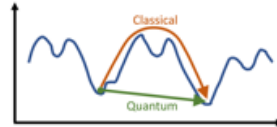

Secure
Airspace
Communication

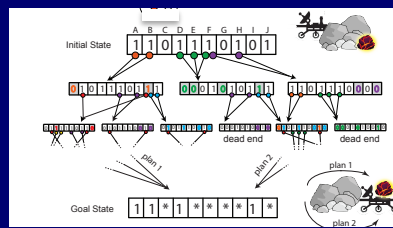
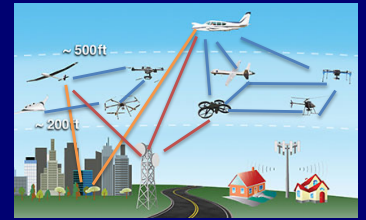

Quantum
Optimization
for Mission
Planning &
Coordination

Entanglement



Air Traffic
Management

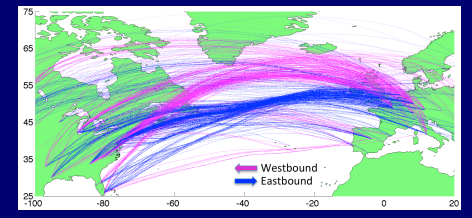

Find "BETTER" solution: faster time-to-solution OR more precise solution OR found using less energy OR not found by classical methods

Diversity of Quantum Computing Hardware



Variety of physical implementations, e.g.,

- Superconducting: D-Wave, Google, IBM, Rigetti
- Ion-Trap: Honeywell, IonQ
- Photonic: PsiQuantum, Quandela, Xanadu
- Cold Atom: ColdQuanta [on Int'l Space Station]
- Doped Silicon: Silicon Quantum Computing
- Anyons: Microsoft

NASA quantum computing R&D

- Not developing quantum hardware
- But engaged with variety of key players by providing important insights
- And thereby leverage hardware advances to explore applications of interest to NASA

General Purpose:

Universal quantum processors

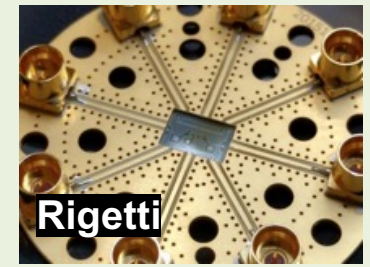
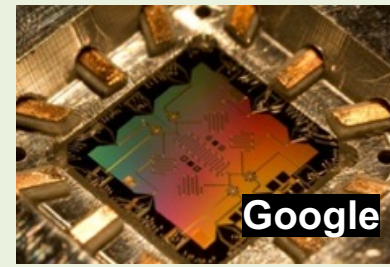

Special Purpose:

Quantum annealers

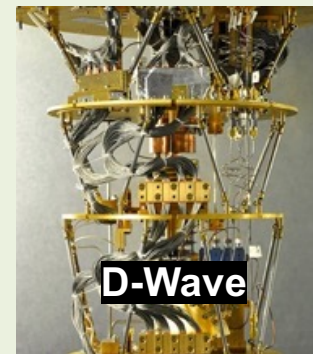

Cold atoms

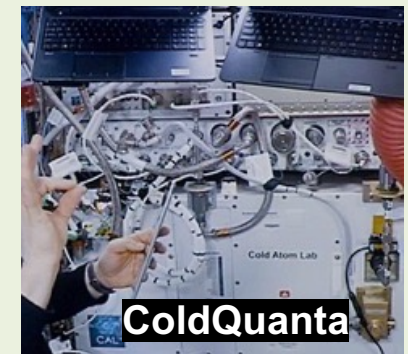



Quantum Computing R&D



Communication & Networks

Quantum networking

Distributed QC

Application Focus Areas

Planning and scheduling

Material science

Fault diagnosis

Machine learning

Software Tools & Algorithms

Quantum algorithm design

Compiling to hardware

Mapping, parameter setting, error mitigation

Hybrid quantum-classical approaches

Solvers & Simulators

Physics-inspired classical solvers

HPC quantum circuit simulators

QuAIL team has published 150+ peer-reviewed papers since 2012

Physics Insights

Co-design quantum hardware

E. Rieffel *et al.* (2019), From Ansätze to Z-gates: A NASA view of quantum computing, *Adv. in Parallel Computing* **34**, 133–160

R. Biswas *et al.* (2017), A NASA perspective on quantum computing: Opportunities and challenges, *Parallel Computing* **64**, 81–98

Quantum Annealing on D-Wave Systems

Quantum Annealing (QA) history

- Nov 2012: 3-way innovative agreement with Google & USRA for QA
- 2013-2020: Several D-Wave chip upgrades to system at NASA Ames, going from ~250 to 4000 qubits
- June 2018: Ames hosts Int'l Adiabatic Quantum Computing (AQC)

What we learned / contributed

- Theoretical understanding of QA suggested that advanced annealing schedule would improve optimization and machine learning (ML)
- When D-Wave implemented advanced schedule feature, orders of magnitude performance improvement was confirmed
- Research uncovered ties between QA schedules and parameter setting for gate-model optimization and ML approaches

J. Marshall *et al.* (2019), Power of pausing: Advancing understanding of thermalization in experimental quantum annealers, *Phys. Rev. Applied* **11**, 044083
Z. Izquierdo *et al.* (2021), Ferromagnetically shifting the power of pausing, *Phys. Rev. Applied* **15**, 044013

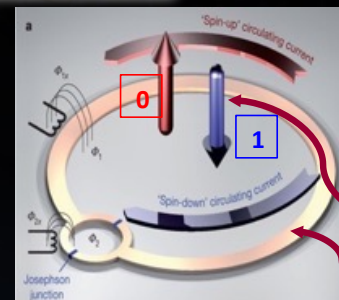
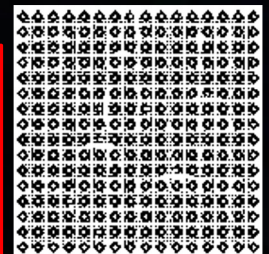
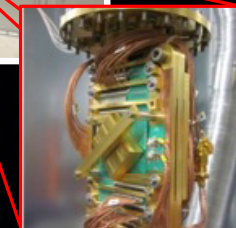
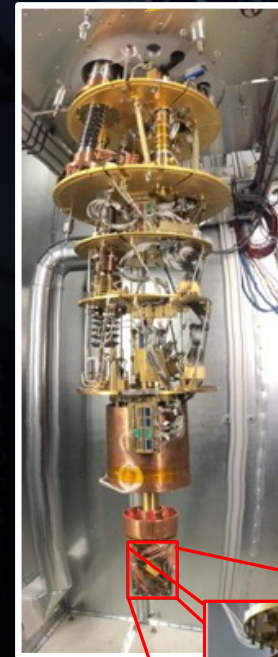
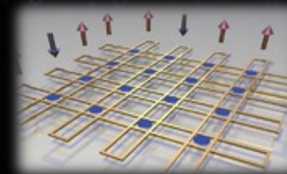
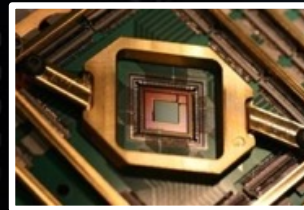

Magnetic Flux

Superconducting Loop

Co-Design with Gate-Model Processors

- Developed **Quantum Alternating Operator Ansatz (QAOA)**, a generalization of Farhi *et al.* Quantum Approximate Optimization Algorithm framework inspired by use cases and hardware compilation considerations
- Introduced more general “mixing operators”
- Collaboration with Rigetti, Inc. under DARPA ONISQ project to evaluate QAOA on their gate-model processors **inspired native hardware implementations** of these general mixing operators

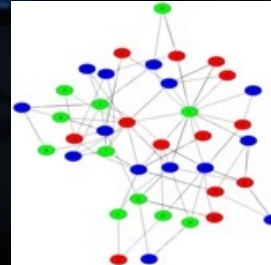

*Problem instance:
Max-K-Colorable subgraph*

*Circuit illustrating the setup with
depolarizing channel \mathcal{E} applied to all qubits*

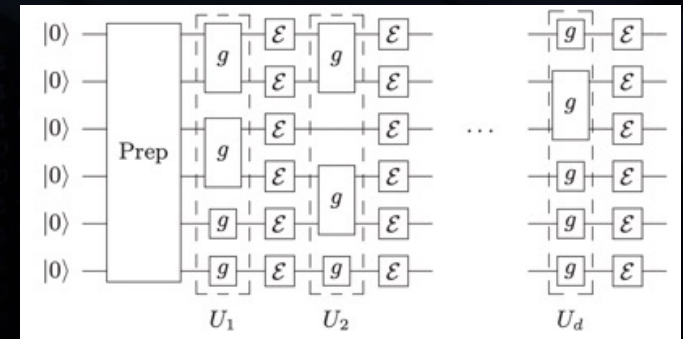

*Approximation ratio for 3-coloring a triangle: QAOA
with standard X-mixer (left) and with XY-mixer (right)*

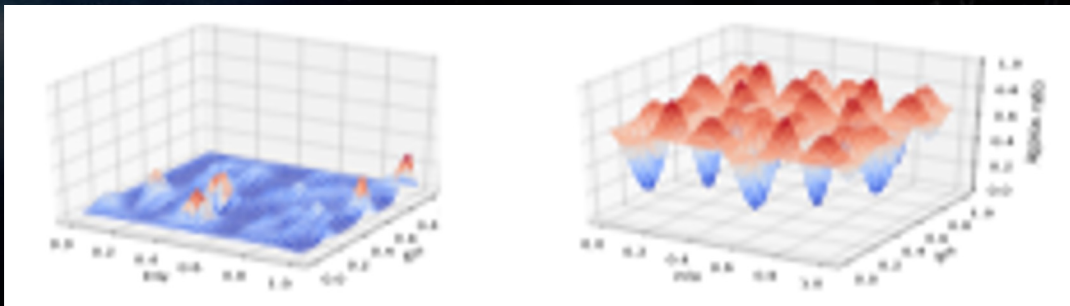

S. Hadfield *et al.* (2019), From the quantum approximate optimization algorithm to a quantum alternating operator ansatz, *Algorithms* **12**, 34 (winner of Algorithms 2020 Best Paper Award)
 Z. Wang *et al.* (2020), XY-mixers: Analytical and numerical results for QAOA pausing, *Phys. Rev. A* **101**, 012320
 M. Streif *et al.* (2021), Quantum algorithms with local particle-number conservation: Noise effects and error correction, *Phys. Rev. A* **103**, 042412

Quantum Tools Development

Use subsystem codes to attain less resource-intensive error mitigation

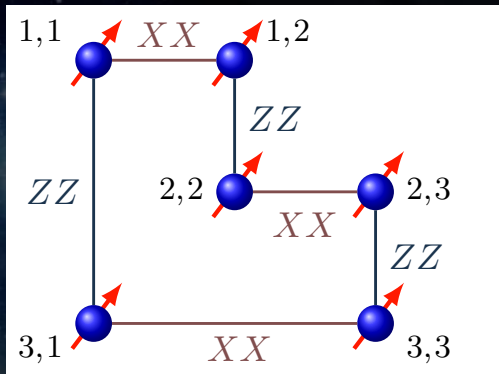

HPC simulation of quantum circuits

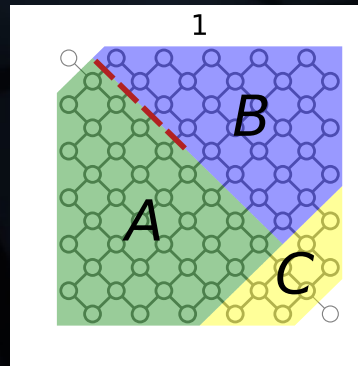

Shadow tomography for error-mitigated expectation values under noise

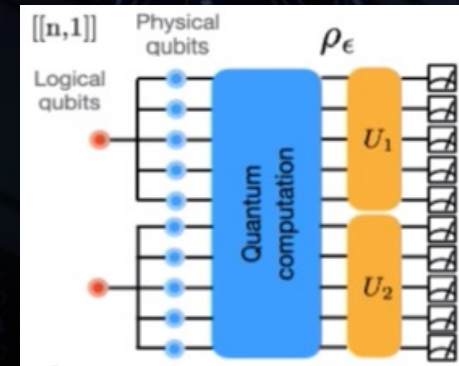

Temporal planning approaches to compiling quantum algorithms

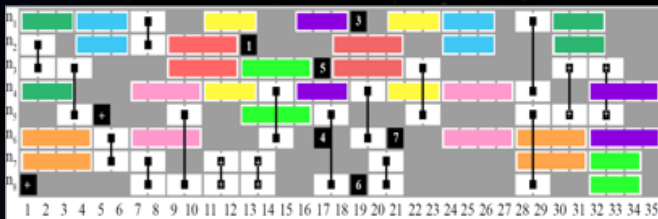

Modeling open quantum systems under environmental noise

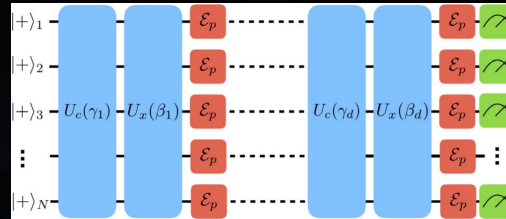

Open quantum system simulations

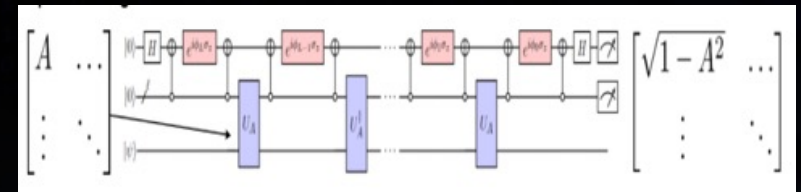

New Era for Quantum Computing

Quantum supremacy achieved 😊

- Perform computations not possible on even the largest supercomputers
- Google – NASA – ORNL collaboration



F. Arute *et al.* (2019),
Quantum supremacy
using a programmable
superconducting
processor, *Nature* **574**,
505-510

Simulator for this work (qFlex) open sourced via
<https://github.com/ngnrsaa/qflex>

More general simulator (HybridQ) open sourced via
<https://github.com/nasa/hybridq>

... but so far only for a toy problem 😡

- Quantum hardware currently too small for solving practical problems intractable on classical supercomputers
- These devices need to scale up and become more reliable

So what to do in the interim?

- Unprecedented opportunity to invent, explore, and evaluate quantum algorithms *empirically*

At NASA

- Develop quantum and hybrid quantum-classical applications for computational challenges in aerospace and Earth science
- Algorithms and applications to enable safer, more ambitious, and greater time- and energy-efficient space exploration missions



Status of Quantum Algorithms

Provable quantum advantage known for a few dozen quantum algorithms

Unknown quantum advantage (incl. most practical problems)

- Even for classical computations
 - Provable bounds hard to obtain
 - Robust analysis is just too difficult
- Best classical algorithm not known for most problems
- Ongoing development of classical heuristic approaches
 - Analyzed empirically: run and see
- Emerging quantum hardware enables evaluation of heuristic quantum algorithms

Handful of proven limitations on quantum computing

Quantum Heuristics will significantly broaden applications of quantum computing

Quantum for Aeronautics

Quantum annealing approaches to de-conflict optimal trajectories for air traffic management

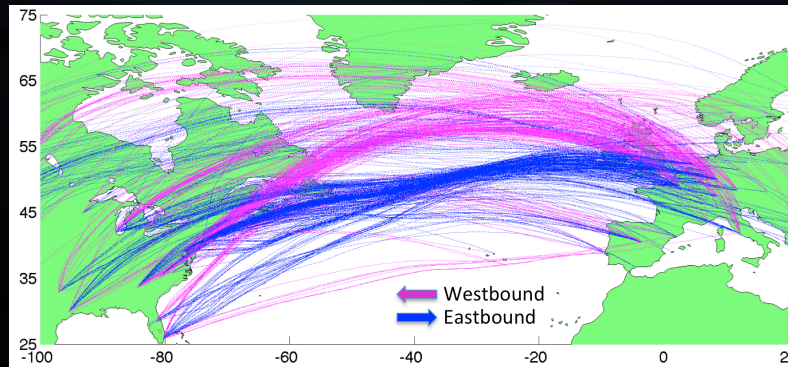

T. Stollenwerk *et al.* (2020), Quantum annealing applied to de-conflicting optimal trajectories for air traffic management, *IEEE Trans. Intell. Transp. Syst.* **21**, 285-297

Quantum algorithms to optimize information sharing in bandwidth-limited autonomous settings

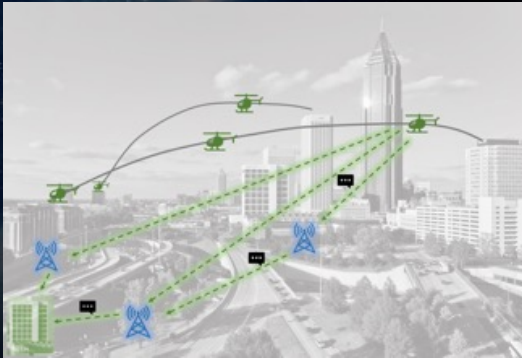

Z. Izquierdo *et al.* (2022), The advantage of pausing: Parameter setting for quantum annealers (to appear)

First-ever demo incorporating solutions from a quantum system into an UAV flight test



Feasibility of QIS to address cybersecurity of communication availability for future air traffic

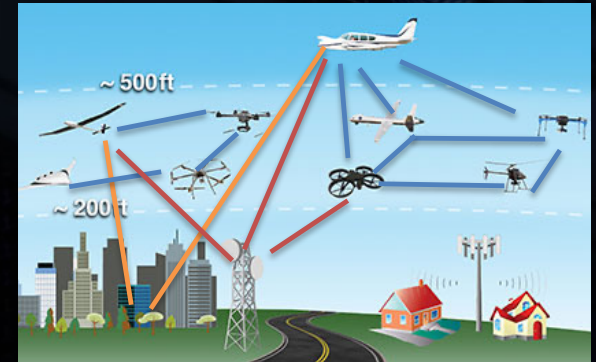

N. Cramer *et al.* (2020), Enhanced UAS availability via vehicle-to-vehicle routing scaled experiments, *AIAA Aviation Forum*, 2020-2850

Quantum for Earth Science



N. Gao *et al.* (2020), High-dimensional similarity search with quantum-assisted variational autoencoder, *KDD '20*, 956-964

Quantum-assisted variational autoencoder

- “Similarity” search applied to NASA’s MODIS dataset
- Multi-variate time series of land cover change
- 17 years of satellite observations over 36 spectral bands
- Extend to segmentation, reconstruction, super-resolution

Optimizing quantum heuristics with meta-learning

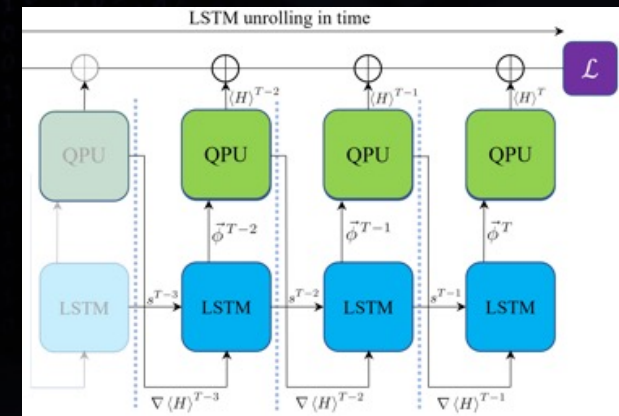

M. Wilson *et al.* (2019), Optimizing quantum heuristics with meta-learning, *arXiv:1908.03185*

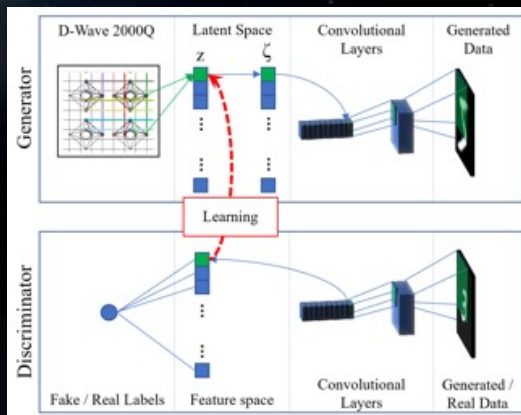

Quantum-assisted associative adversarial network

M. Wilson *et al.* (2019), Quantum-assisted associative adversarial network: Applying quantum annealing in deep learning, *arXiv:1904.10573*

Quantum for Space Exploration

Quantum computing for mission planning and scheduling

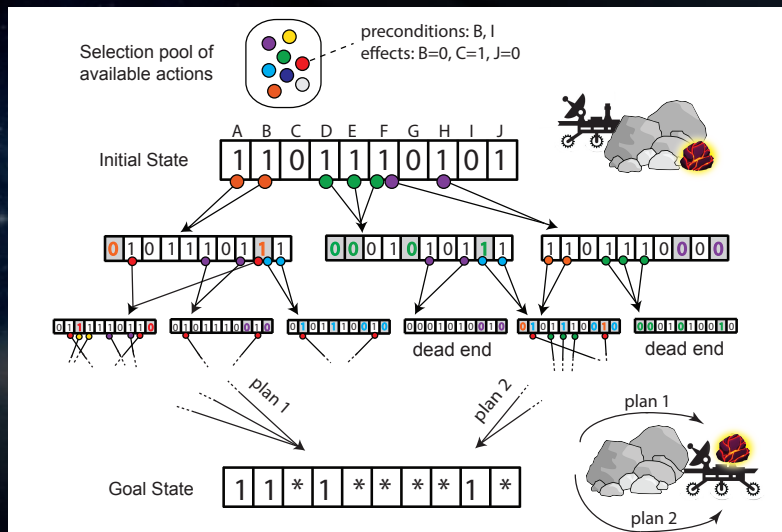

E. Rieffel *et al.* (2015), A case study in programming a quantum annealer for hard operational planning problems, *Quantum Inf. Process.* **14**, 1-36

T. Tran *et al.* (2016), Explorations of quantum-classical approaches to scheduling a Mars lander activity problem, *Workshops of 30th AAAI Conf. on AI Planning for Hybrid Systems*

Quantum networks to provide distributed quantum resources via entanglement swapping

- Vision of a space-ground quantum network
- Applications to long baseline telescopes, sensor arrays, and distributed quantum computing

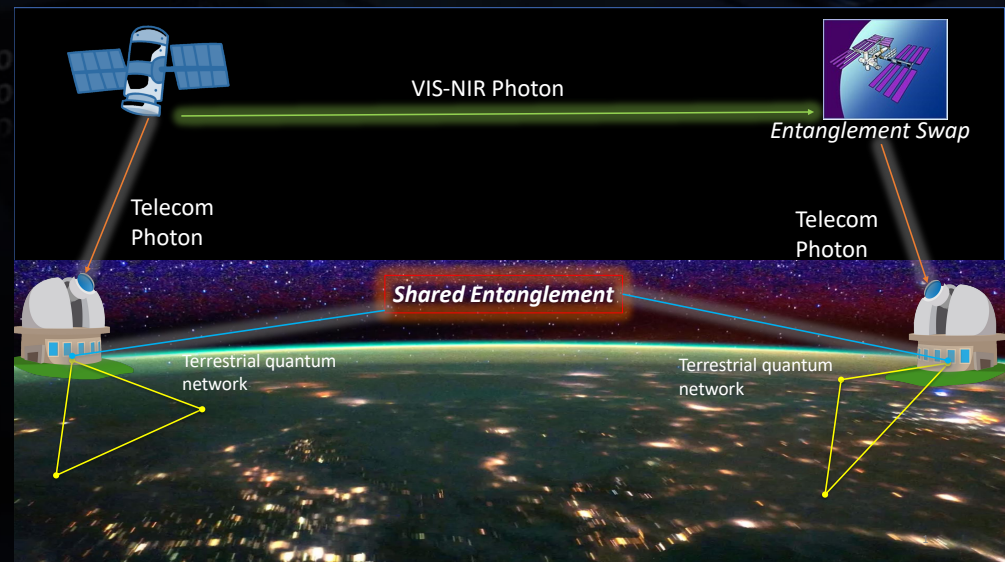

Quantum for Materials Discovery

Developed variational quantum phase estimation algorithm as more efficient way to measure ground and excited state energies

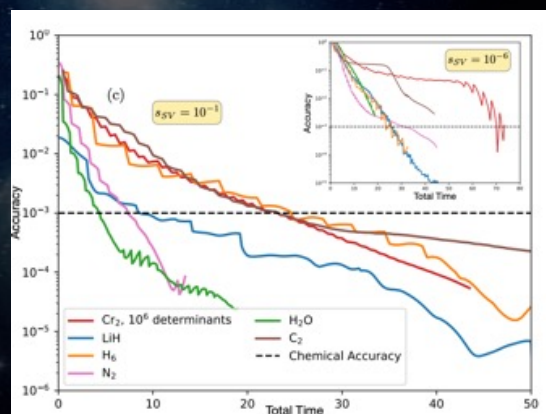

K. Klymko *et al.* (2021), Real time evolution for ultracompact Hamiltonian eigenstates on quantum hardware, [arXiv:2103.08563](https://arxiv.org/abs/2103.08563)

Adapted Quantum Alternating Operator Ansatz (QAOA) to find ground states in quantum chemistry problems

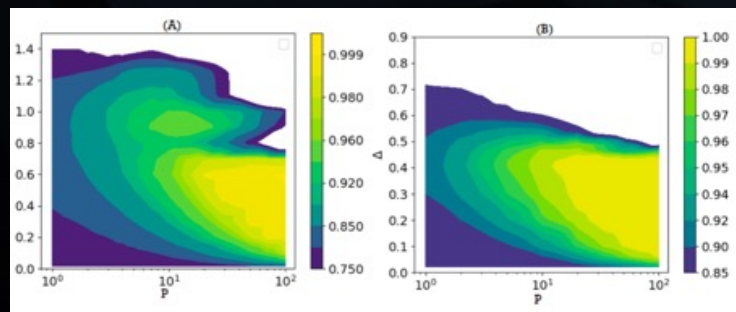

V. Kremenetski *et al.* (2021), Quantum Alternating Operator Ansatz (QAOA) phase diagrams and applications for quantum chemistry, [arXiv:2108.13056](https://arxiv.org/abs/2108.13056)

Examined two approaches to speeding up adiabatic state preparation when performed on quantum hardware

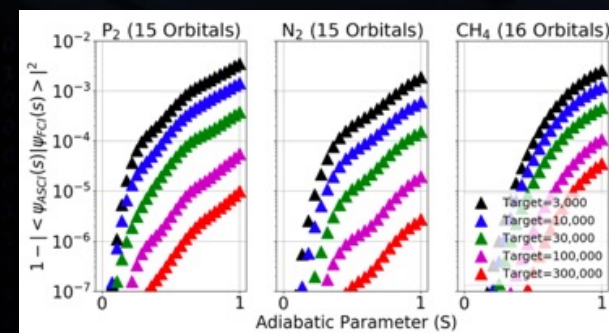

V. Kremenetski *et al.* (2021), Simulation of adiabatic quantum computing for molecular ground states, [arXiv:2103.12059](https://arxiv.org/abs/2103.12059)

Quantum Noise Characterization

Extended character randomized benchmarking to explicitly treat non-multiplicity-free groups and derived several applications

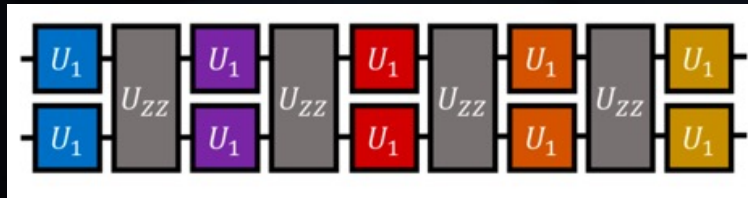

Developed and applied multi-qubit dynamical decoupling sequences to characterize noise that occurs during 2-qubit gates

Developed method to faithfully reconstruct local approximation of the effective noise channel for quantum computers

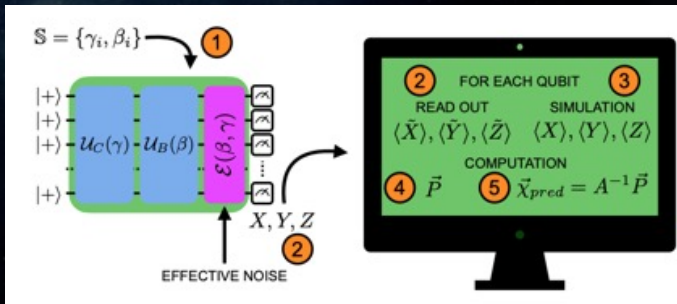

J. Sud *et al.* (2021), Dual map framework for noise characterization on quantum computers, *arXiv:2112.04414*

J. Claes *et al.* (2021), Character randomized benchmarking for non-multiplicity-free groups with applications to subspace, leakage, and matchgate randomized benchmarking, *arXiv:2011.00007*

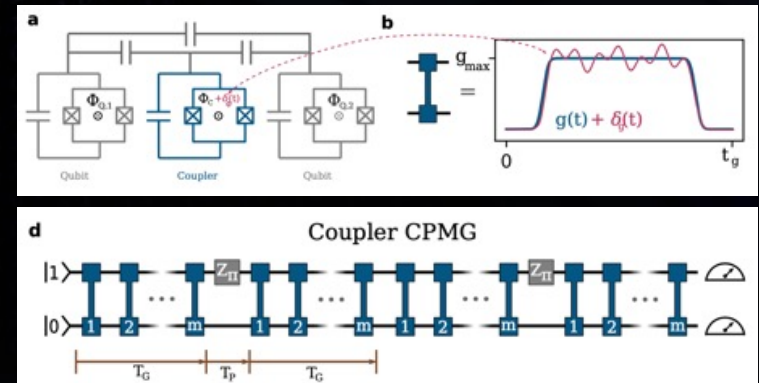

T. McCourt *et al.* (2022), Learning noise via dynamical decoupling of entangled qubits, *arXiv:2201.11173*

QC and Quantum Networks

Networking quantum computers enables **larger quantum computations**

- Envision heterogeneous system of quantum processors, with differing strengths, incl. special purpose processors
- Leverage such system through quantum networks connecting quantum processors and routing quantum subroutines to appropriate processors

Delegated quantum computing enables a very limited quantum device to perform quantum computation via connection to full quantum processor

Verifiable quantum computing enables client to check if desired quantum computation has been performed

- Means to benchmark quantum computing hardware
- Security applications in the long term

Blind quantum computing enables client to use quantum processors without the provider learning anything about computation

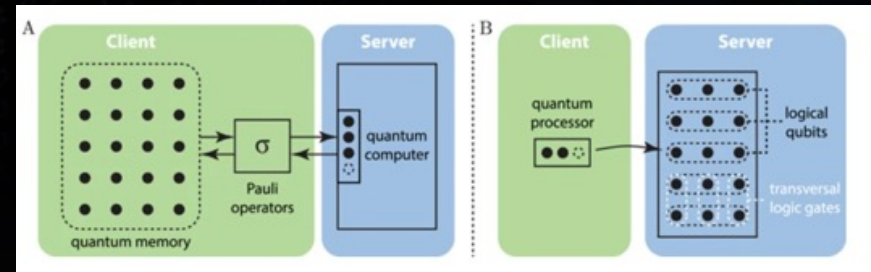
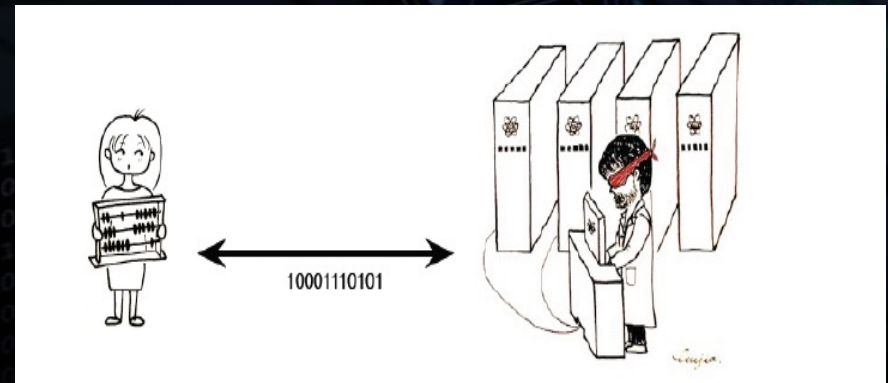

J. Fitzsimons (2017), Private quantum computation: An introduction to blind quantum computing and related protocols, *npj Quantum Info.* 3

QC and Quantum Sensing

Demonstration of a reconfigurable entangled radio frequency photonic sensor network

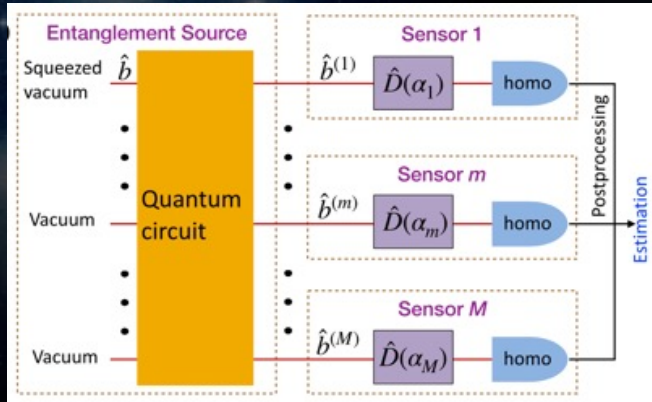

Y. Xia *et al.* (2020), Demonstration of a reconfigurable entangled radio-frequency photonic sensor network, *Phys. Rev. Lett.* **124**, 150502

Very Long Baseline Interferometry (VLBI) advantageous to store arriving photons in quantum memory than QFT

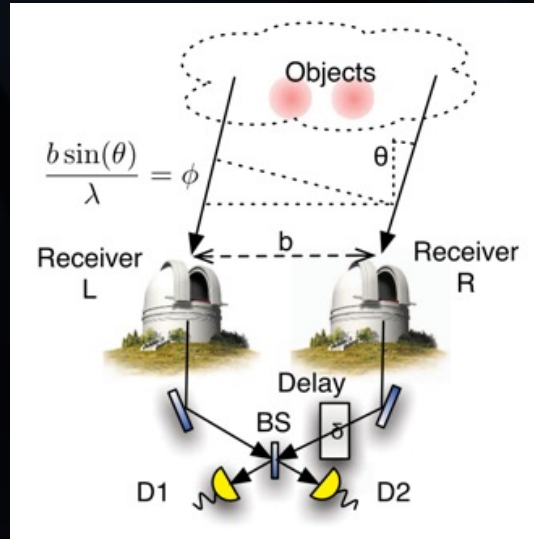

D. Gottesman *et al.* (2012), Longer-baseline telescopes using quantum repeaters, *Phys. Rev. Lett.* **109**, 070503

Physical-layer supervised learning assisted by an entangled sensor network

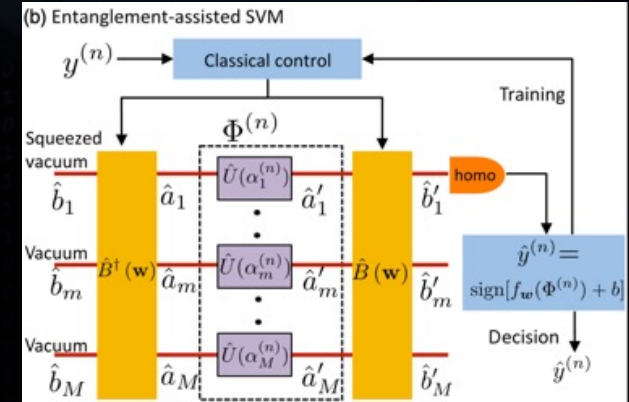

Q. Zhuang *et al.* (2019), Physical-layer supervised learning assisted by an entangled sensor network, *Phys. Rev. X* **9**, 041023

Quantum Computing Going Forward

Understanding and harnessing the power of quantum computing is a formidable challenge

- New insights into physics, mathematics, and computer science
- Breakthroughs in engineering design to produce robust, reliable, scalable technologies
- Innovative algorithms and tools in computer and computational science
- Diverse workforce with appropriate expertise to leverage this new paradigm

Exciting future in quantum computing ahead of us

- Small-scale universal quantum chips becoming available
- New and better quantum algorithms, particularly quantum heuristics, emerging
- Compilation and performance capabilities improving rapidly

ENIAC (1946), the first “general-purpose” computer

The task of taking a problem and mapping it onto the machine was complex, and usually took weeks. After the program was figured out on paper, the process of getting the program "into" ENIAC by manipulating its switches and cables took additional days. This was followed by a period of verification and debugging [...]

(source: <http://en.wikipedia.org/wiki/ENIAC>)

GLOBAL

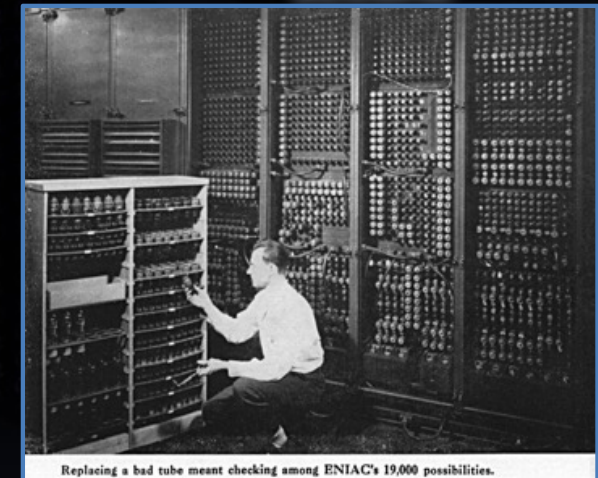

NASA Advanced Computing Environment



Enable the science & engineering required to meet NASA's missions and goals

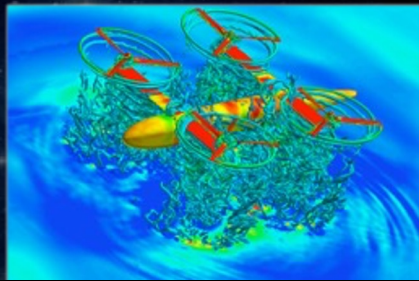

Quadcopter Drone Analysis

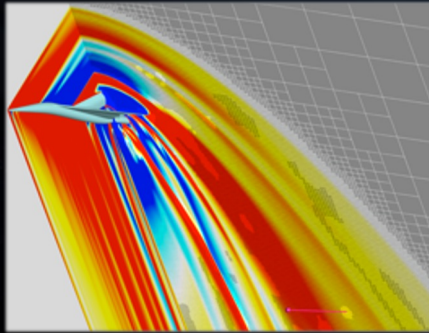

Sonic Boom Prediction

LAUNCH

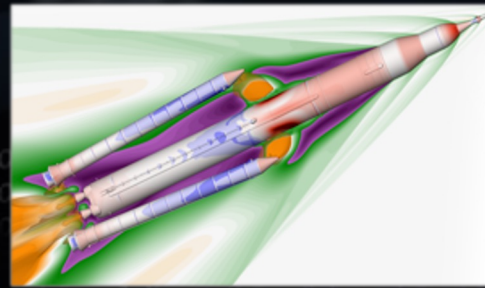

SLS Booster Separation



Launch Environment

GLOBAL CIRCULATION



X59 Flight Demonstrator

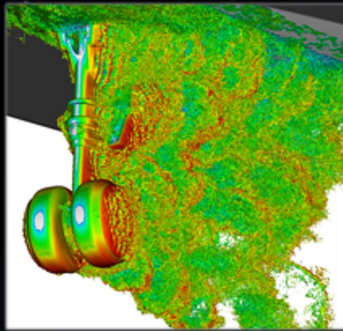

Landing Gear Noise

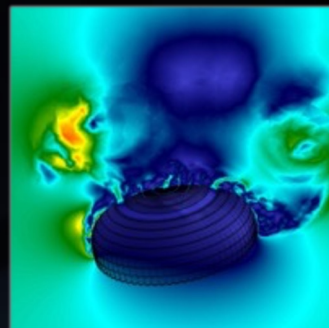

Orion Parachute Dynamics



Magnetic Fields in Corona

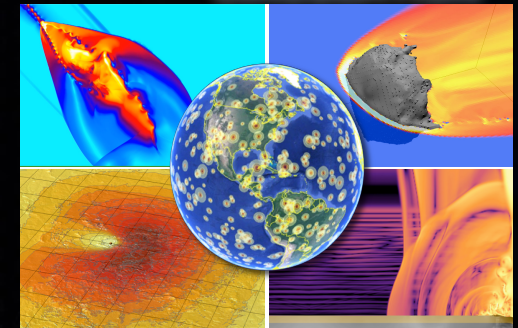

Asteroid Impact Assessment



*Concept image