

Particle and Trace Gas Emissions Indices Measured During the 2021 Boeing ecoDemonstrator Emissions Ground Test



Richard H. Moore, Steven L. Baughcum, Matthew D. Brown,
Elizabeth B. Wiggins, Edward L. Winstead, Luke D. Ziemba, Joshua DiGangi,
Michael A. Shook, Kevin J. Sanchez, Benjamin Nault, Richard C. Miake-Lye,
Andrew Freedman, Francisco Guzman, Jennifer L. Klettlinger,
and the Boeing ecoDemonstrator Science and Engineering Team

richard.h.moore@nasa.gov; Twitter: @richardhmoore

Great Potential of SAF and Advanced Combustor Technology

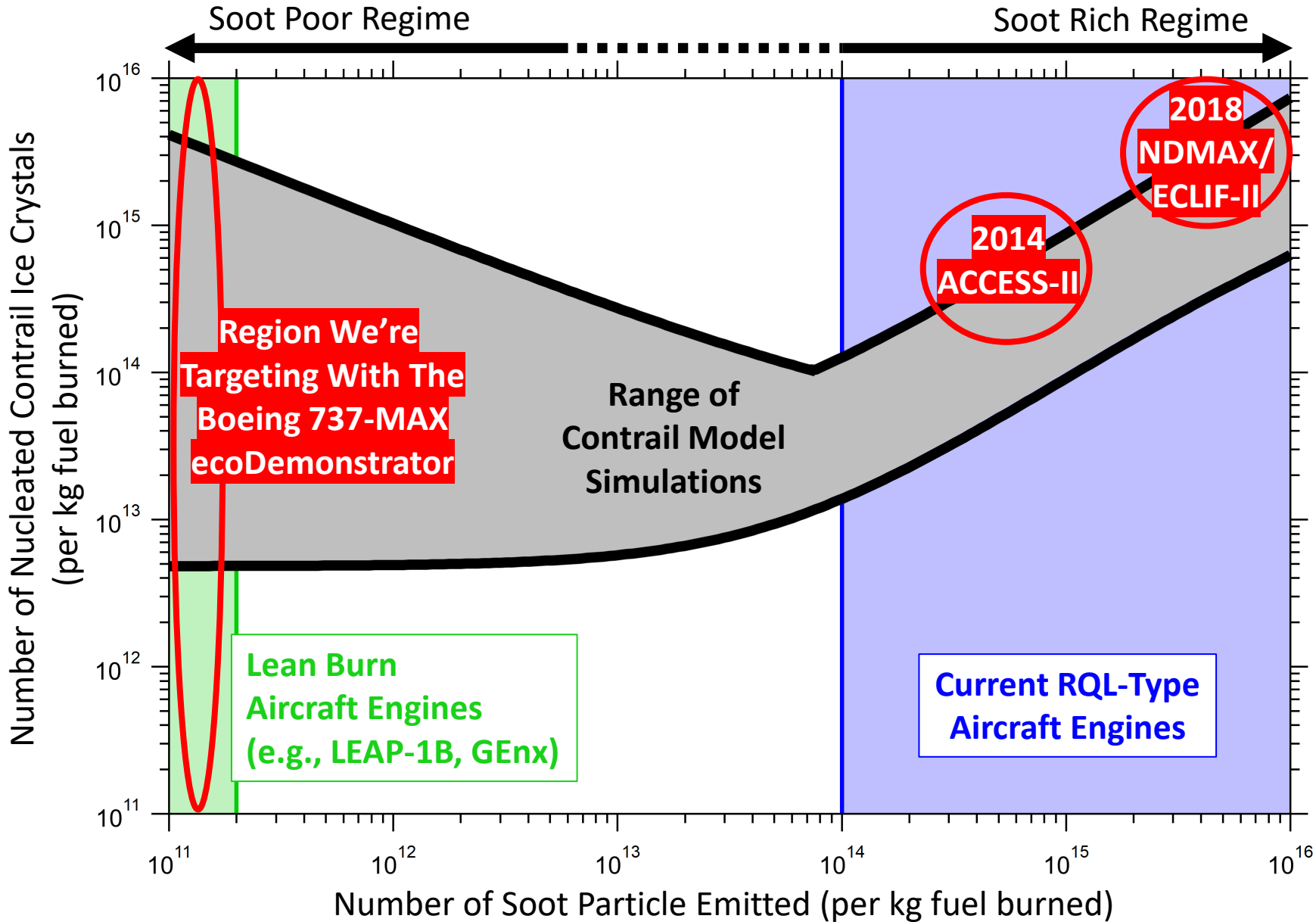

Need to understand engine particle emissions in the “soot-poor” regime in order to connect to contrail formation and climate impacts

Emissions reductions also beneficial for air quality

Figure adapted from Kärcher, *Nature Communications*, 2018.

Red circles show the approximate Number EIs observed during the 2014 ACCESS-II and 2018 ND-MAX/ECLIF-II flight test series.

Moore et al., *Nature*, 2017; Voigt et al., *Nature Comms. Earth & Environ.*, 2021

Fuel Composition Does Not Necessarily Scale Linearly With %SAF



- Investigated four fuels:
 - 100% SAF
 - 50% SAF with Jet A¹
 - 30% SAF with Jet A²
 - 100% Jet A³
- Good linearity between aromatics and %hydrogen
- 50% SAF tested is NOT halfway between 0% and 100% in terms of aromatics or %hydrogen

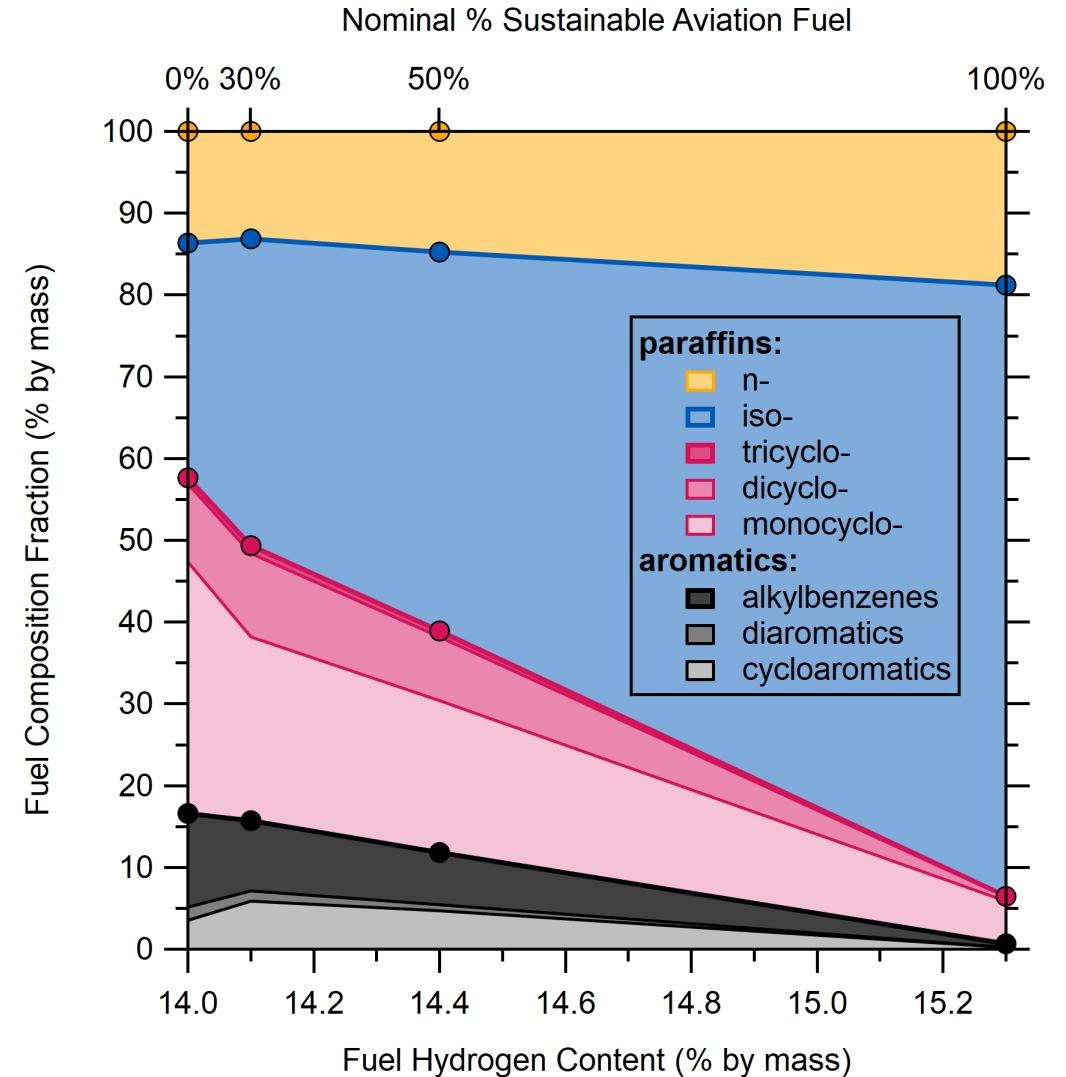

Theoretical line losses are very low, owing to short transmission line

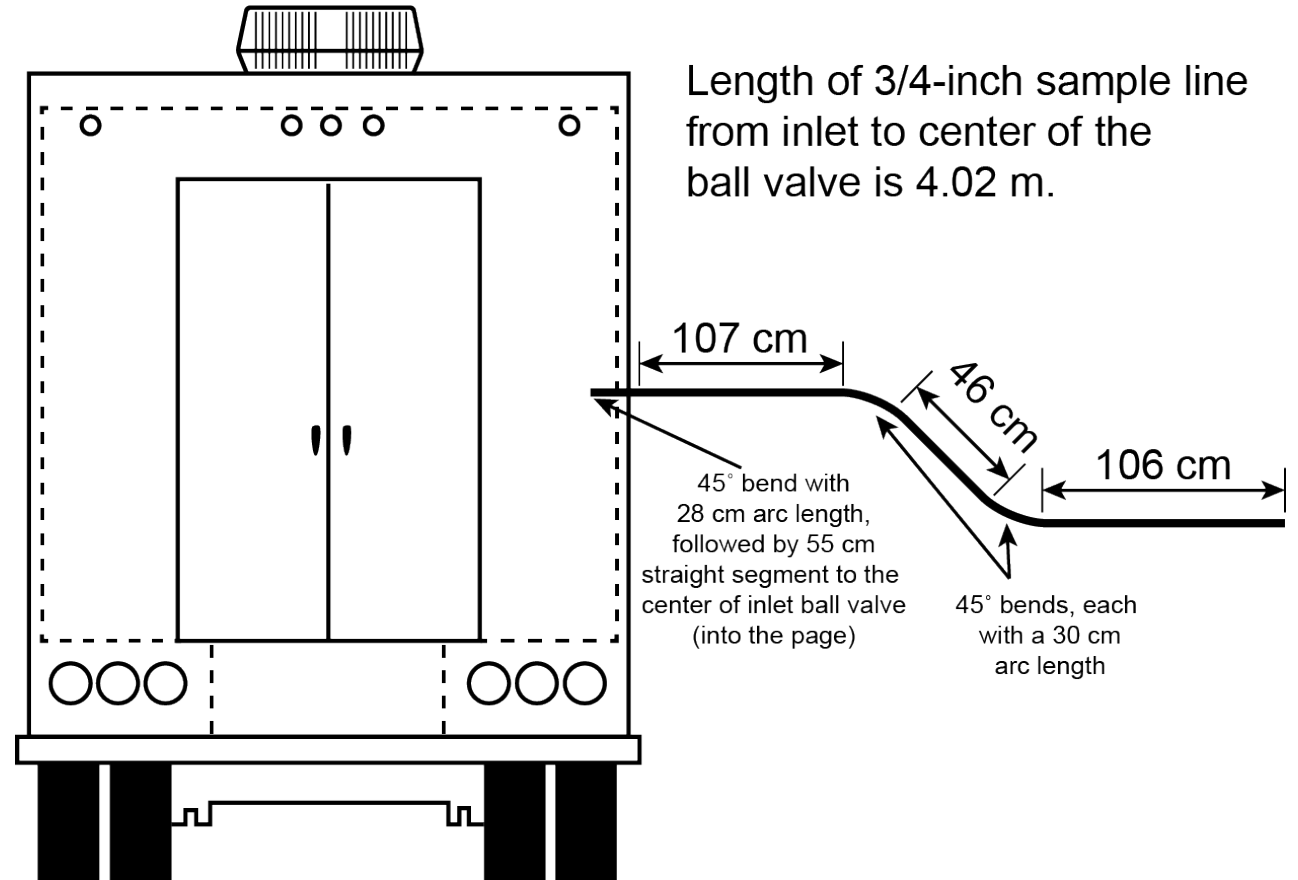
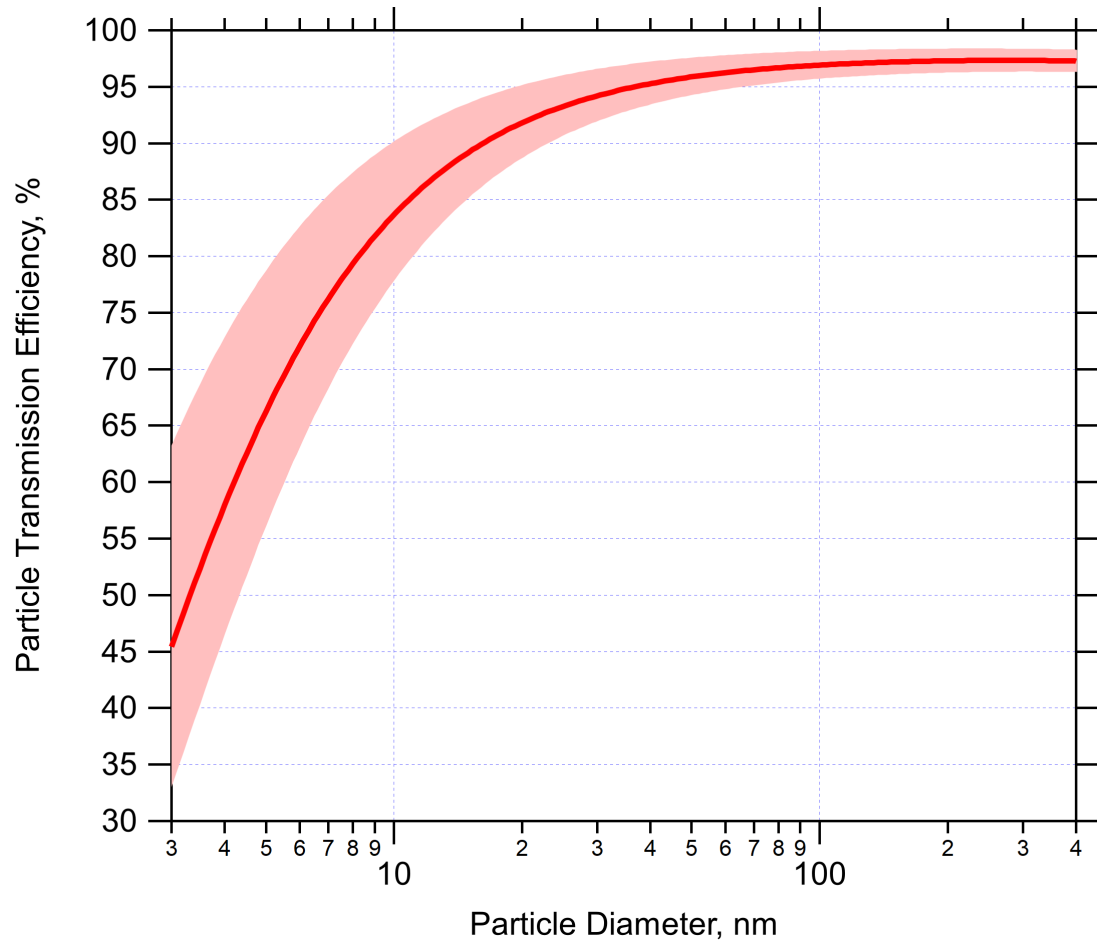

Test Matrix Sampled 8 Thrust Conditions Both in Ascending, Descending

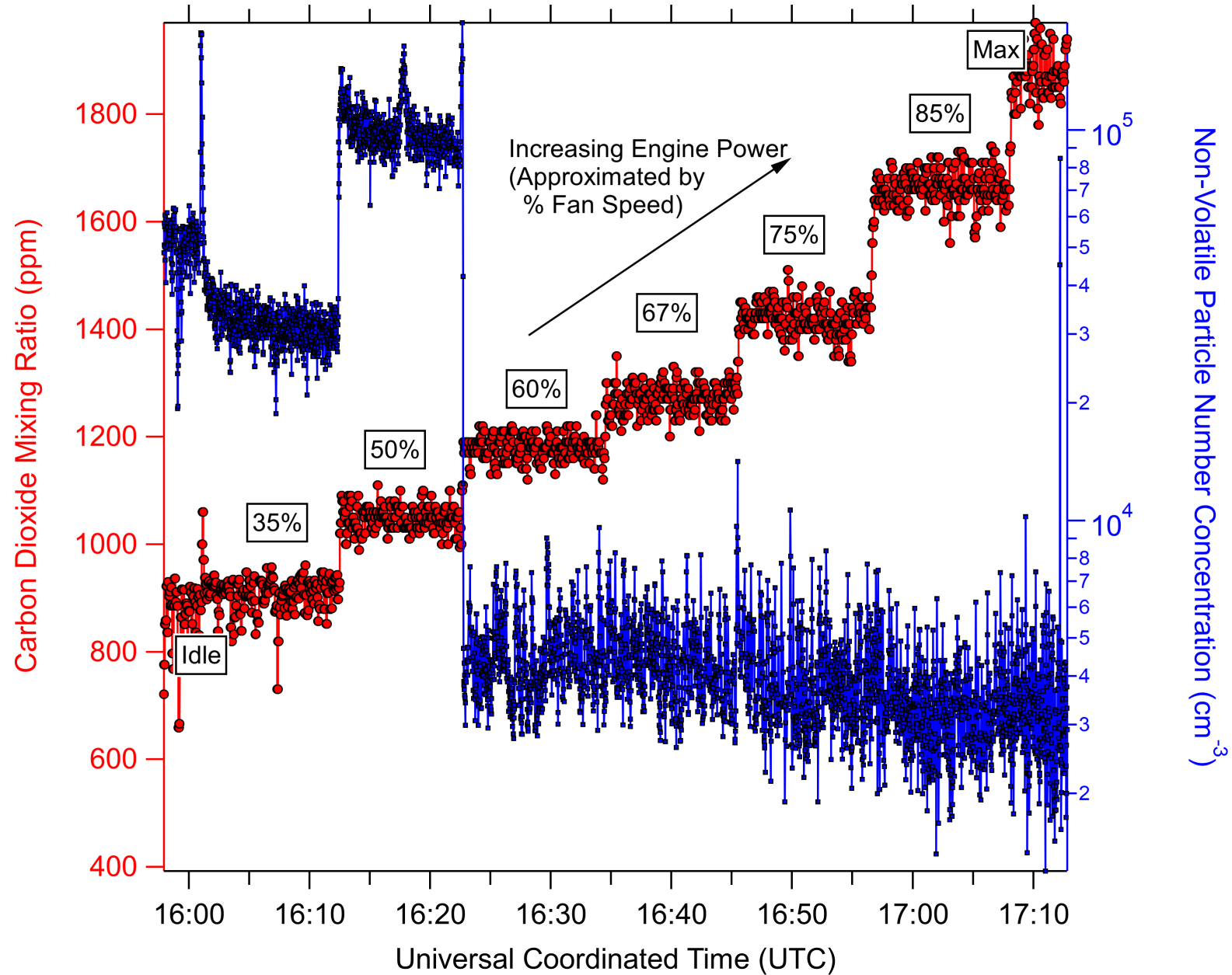

Trace Gas Emissions Indices Invariant With Fuel (as expected)

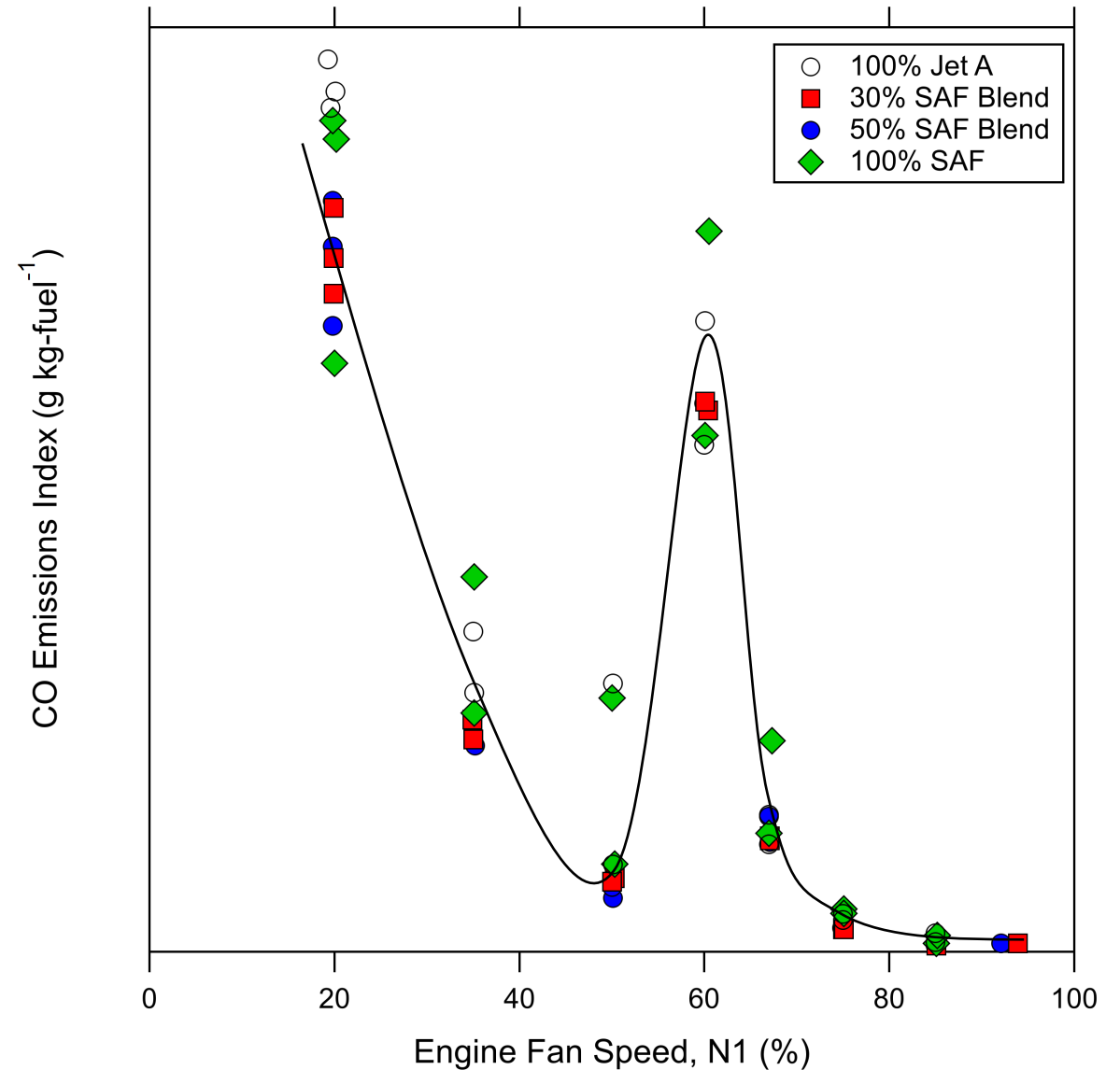
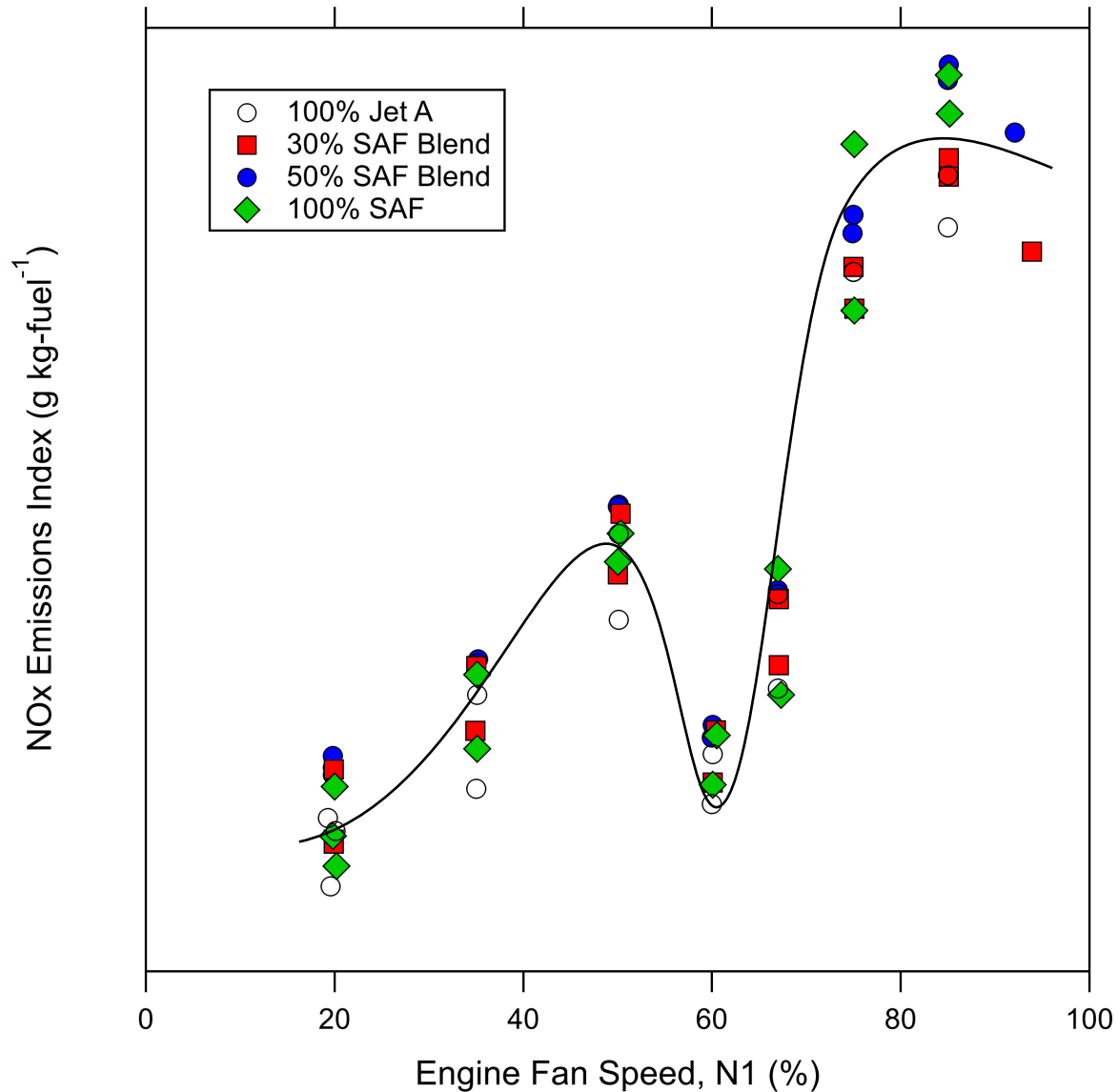

Lines included to guide the eye

Significant Fuel Impacts on Non-Volatile and Total Particle Number

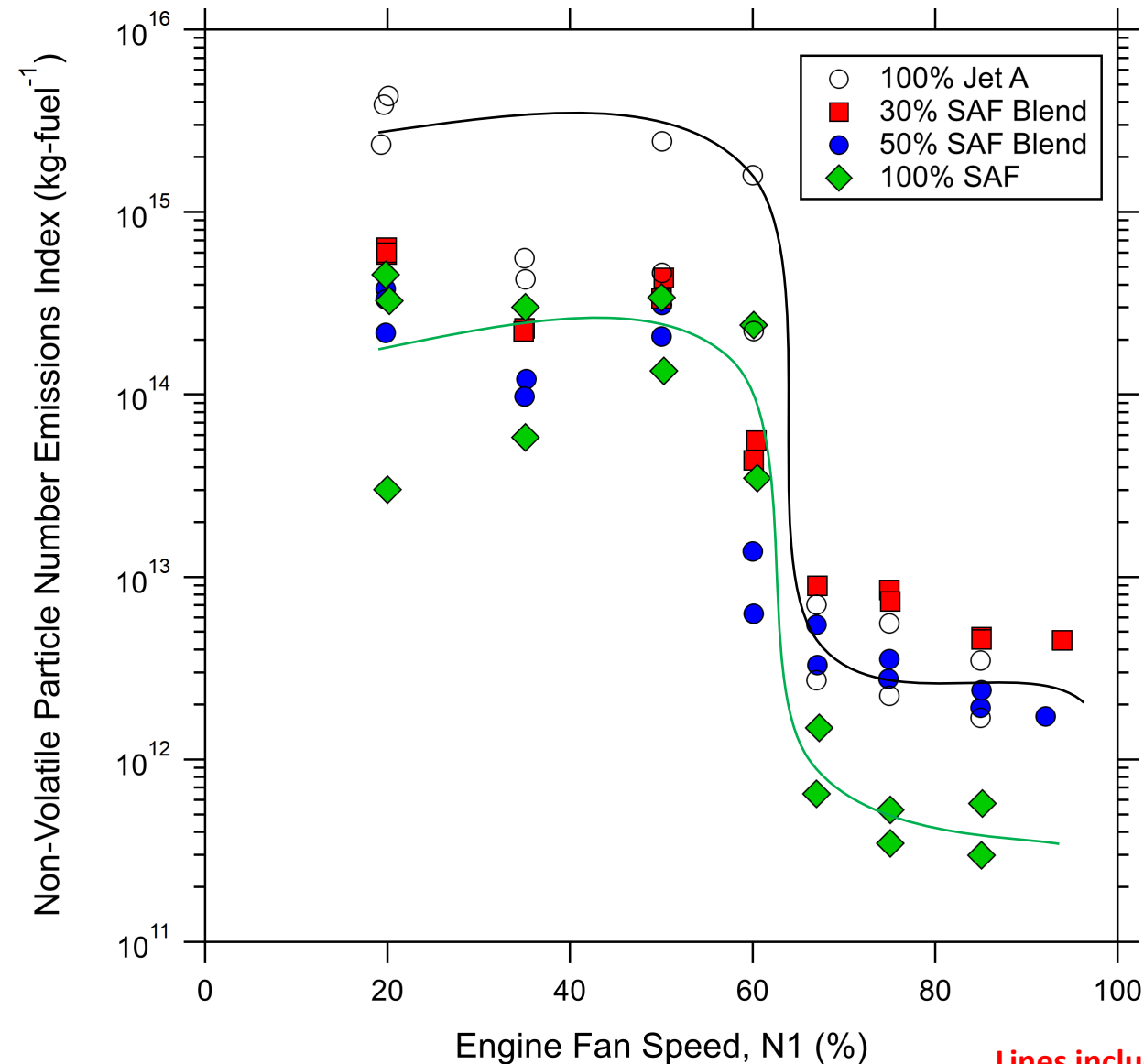
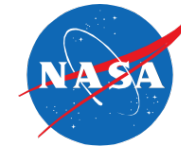

Lines included to guide the eye

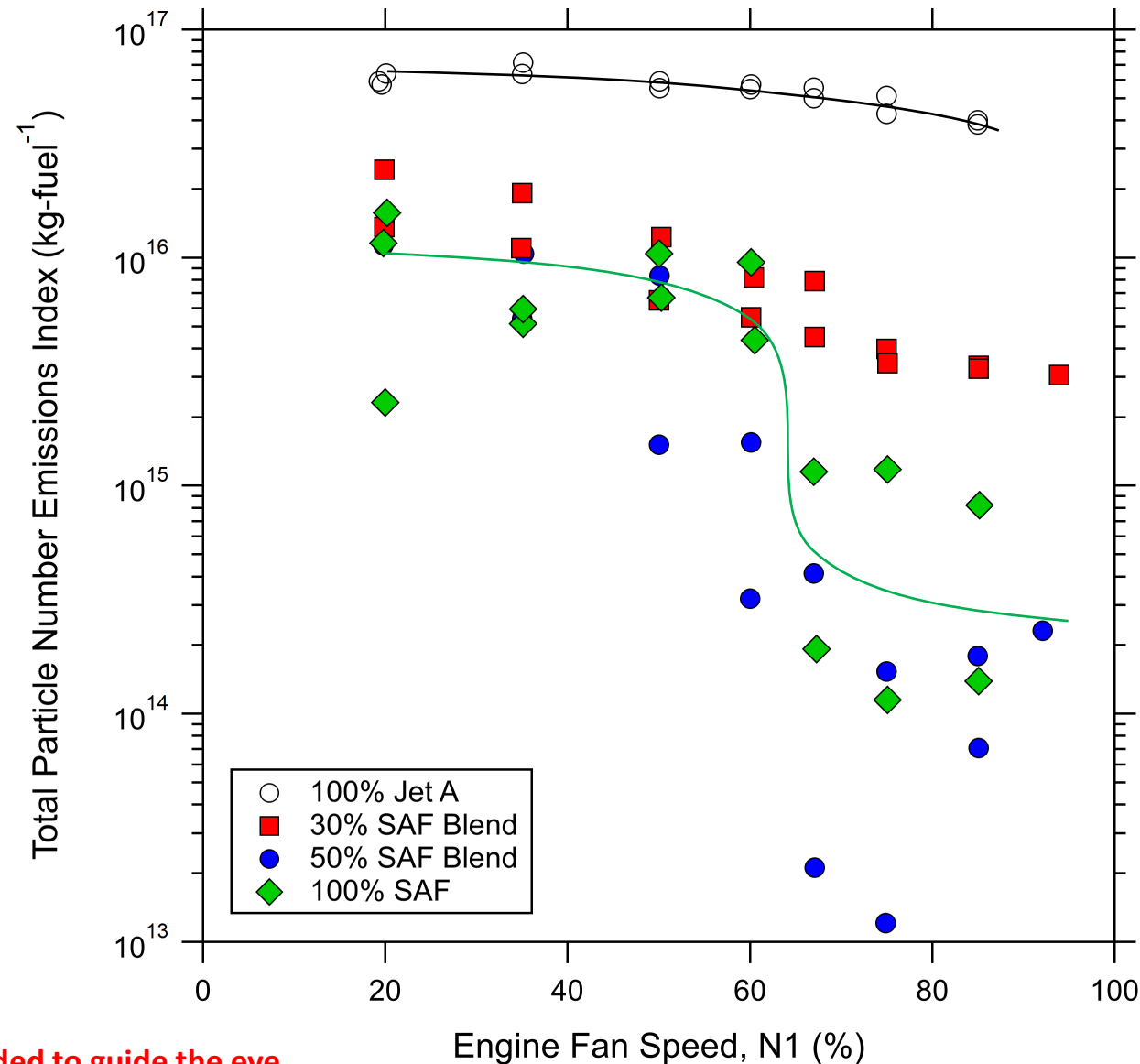

Fuels Also Impact Black Carbon Mass; Although, Noisy Because Absorption-Based Mass Measurements Are Near Background Values

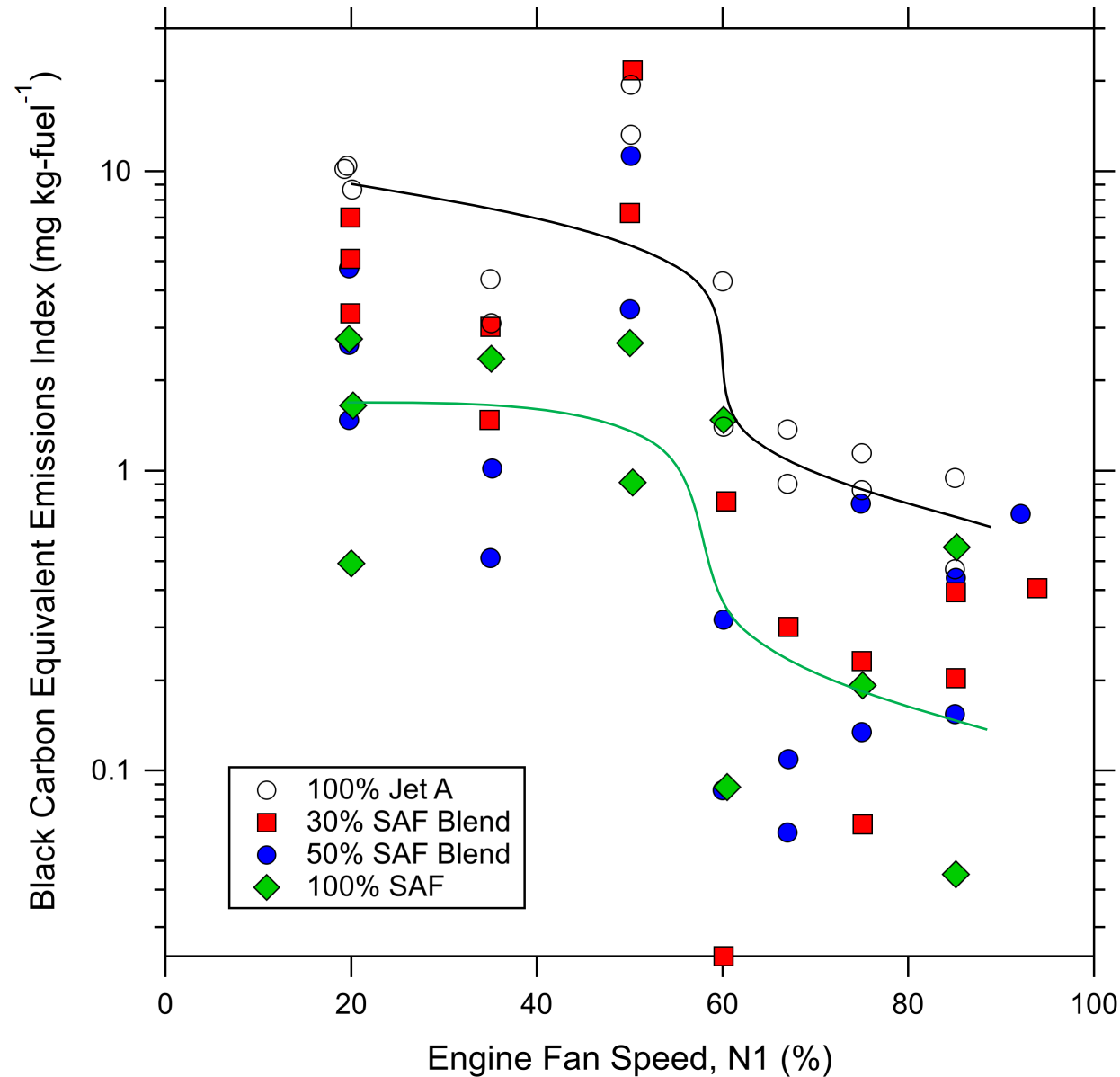

Lines included to guide the eye

Example Size Distributions at 85% Thrust Demonstrate The Challenge With Integrated Mass (Volume) Measurements Versus Number

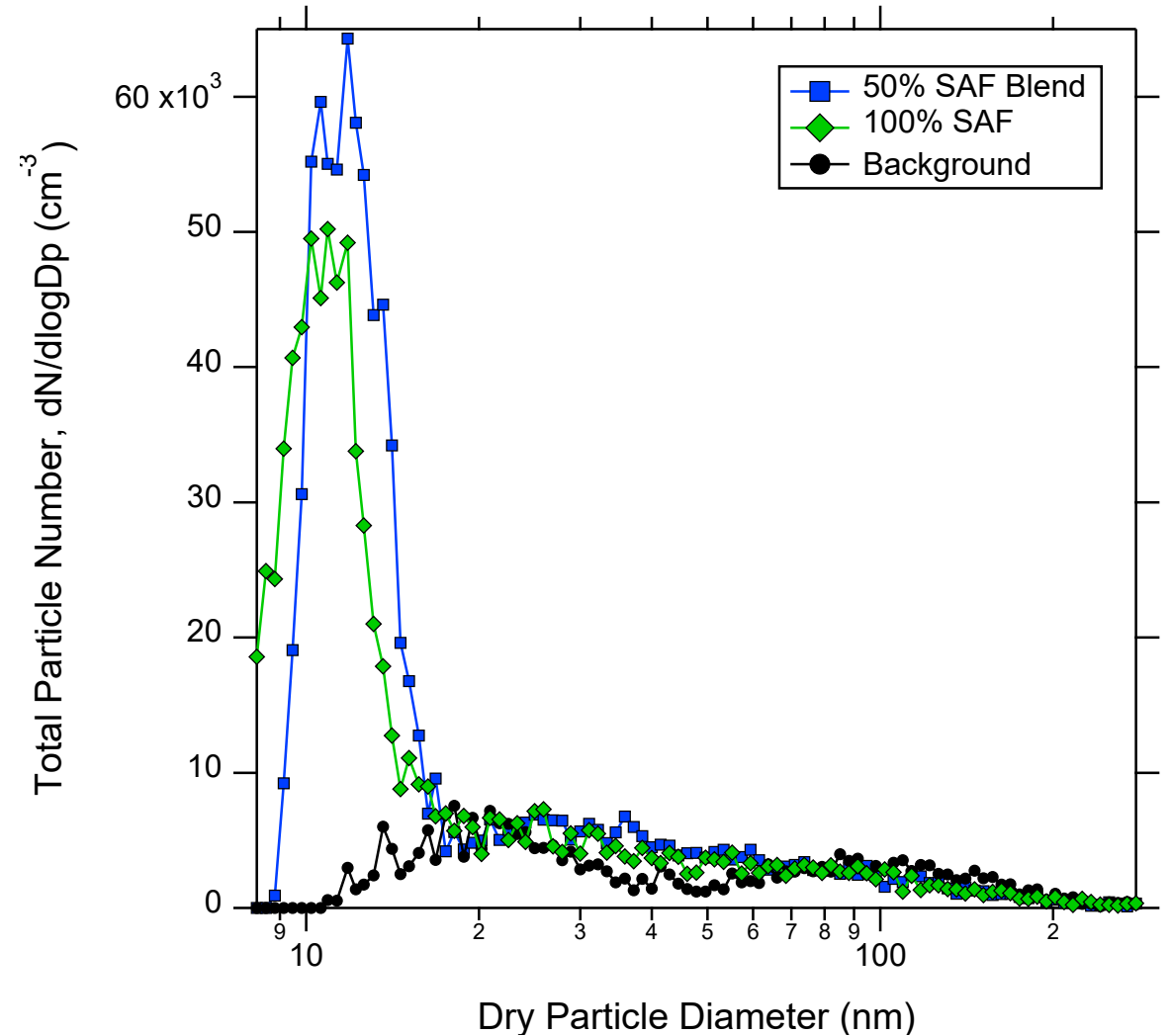
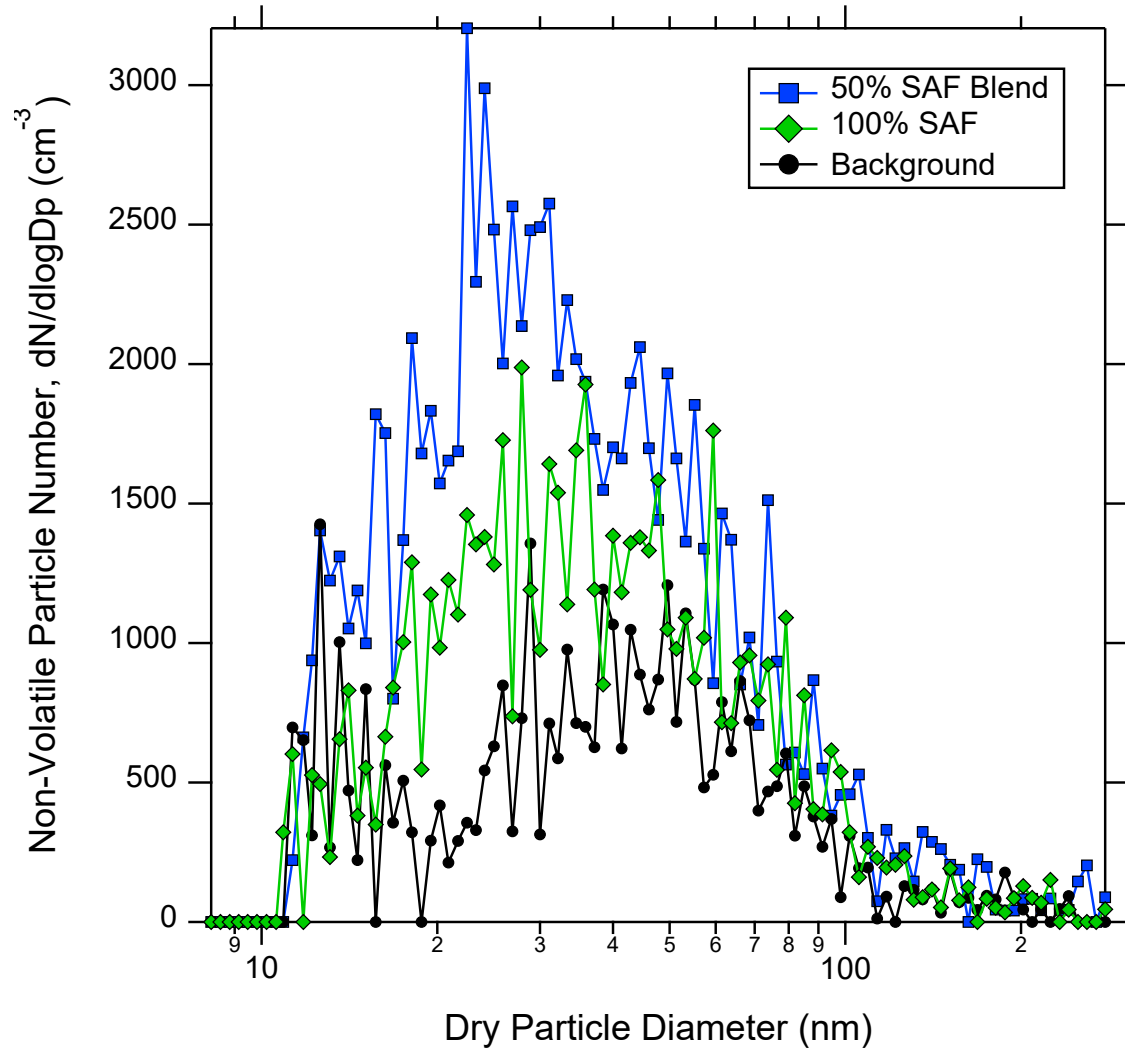



Take Home Points

- Staged lean burn engines + 100% SAF yield dramatic particle emissions reductions
 - $\sim 10^{14}$ to $\sim 10^{11}$ per kg-fuel for non-volatile particle number
 - $\sim 10^{16}$ to $\sim 10^{14}$ per kg-fuel total particle number
 - ~ 10 - 100 to <1 mg per kg-fuel for particle mass
- 100% SAF also lowers particle emissions even at low power conditions (relevant for air quality)
- High fuel sulfur content yield large numbers of volatile particles even at high thrust
- Low-emitting engines emphasize the need for on-wing measurements
 - Ground measurements with short sampling lines minimize losses and improve signal-to-noise
 - Ground measurements can cover many power settings and allow for more detailed information (e.g., size distributions)
 - Cruise measurements connect the detailed measurements on the ground to real-world, contrail-forming conditions

