

National Aeronautics and
Space Administration

EXPLORE MARS

Challenges of Building, Launching, and Operating The Curiosity SAM Instrument on Mars

Florence Tan

Deputy Chief Technologist

NASA Science Mission Directorate

Chair, SmallSat Coordination Group

NASA Headquarters

NASA's Key Science Themes

PROTECT & IMPROVE
LIFE ON EARTH &
IN SPACE



SEARCH FOR LIFE
ELSEWHERE



DISCOVER SECRETS
OF THE UNIVERSE





Are we alone in the universe?
Where and how do we search for life?

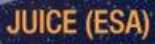

MOON



MARS



- FORMULATION ●
- IMPLEMENTATION ●
- PRIMARY OPS ●
- EXTENDED OPS ●

PLANETARY FLEET

Mars Today: A Cold Desert



Dingo Gap, from *Curiosity*

Why Mars?



Earth



Venus

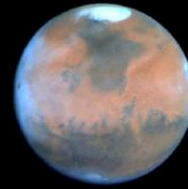

Mars



Mercury



The Moon

Mars has the potential to answer fundamental questions about our Solar System

- The potential for life
- A geological record of the first billion years of planetary evolution
- A drastically changing climate through time
- A compelling target for Human Exploration

Aug 5, 2012 22:23 PDT



Robotic Missions to Mars

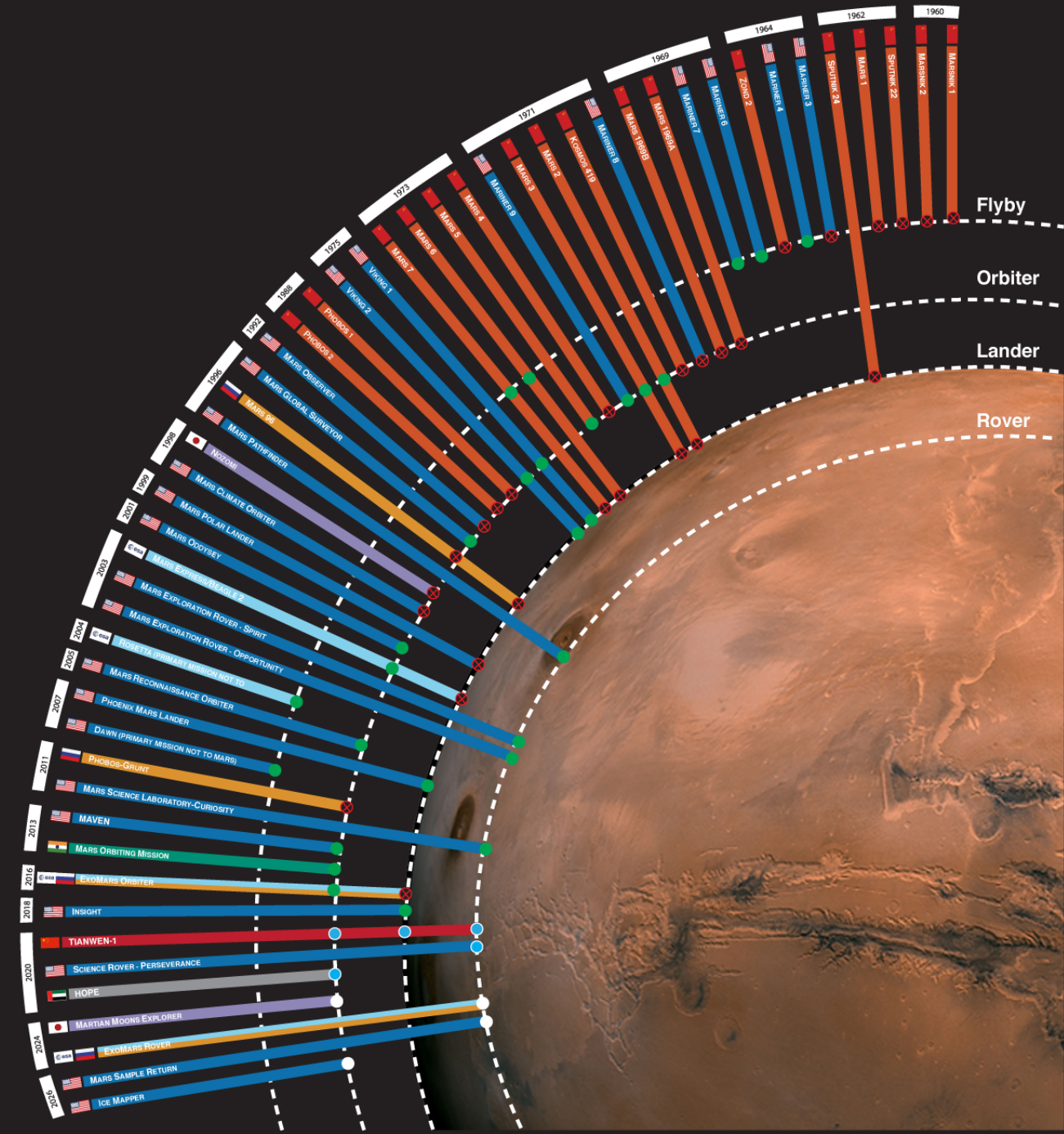
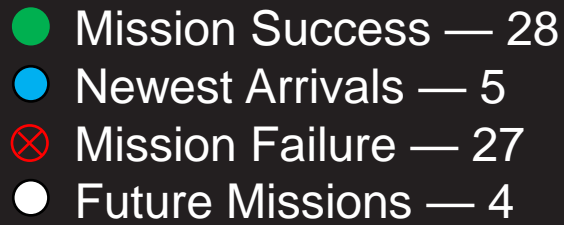

What Have We Learned?



Modern Mars

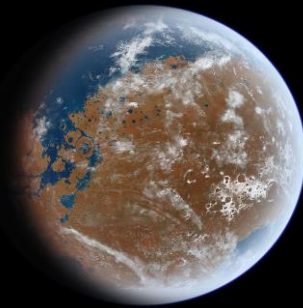

~ 3.6 billion years ago

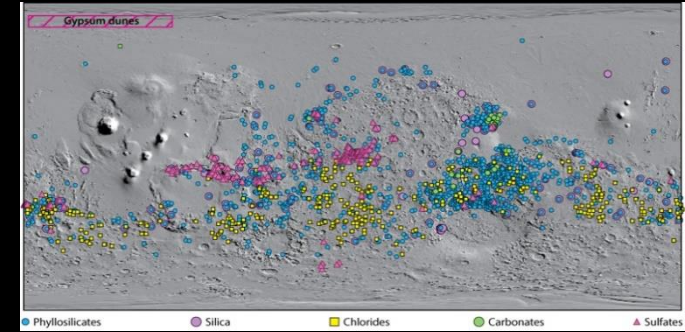

Observed Outcrops of Minerals Formed in Liquid Water *Ehlmann & Edwards (2014)*

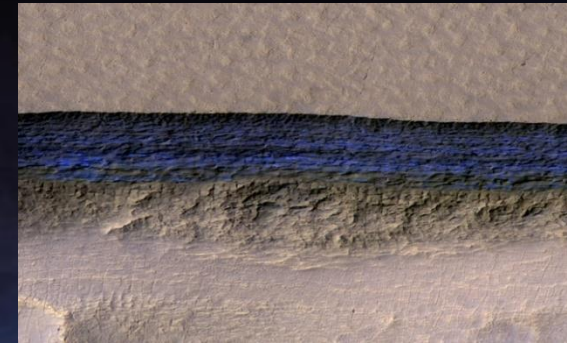

Exposed Mid-latitude Ice Cliff
C. Dundas USGS / U. Arizona / JPL / NASA



2018 Planet-Encircling Dust Event
Cantor & Malin, MSSS / JPL / NASA





Curiosity 1st SELFIE

November 1, 2012

<https://photojournal.jpl.nasa.gov/catalog/PIA16239>

Image Credit: NASA/JPL-Caltech/Malin Space Science Systems

Image Addition Date: 2012-11-01



Curiosity SELFIE

March 30, 2021

NASA/JPL-Caltech/MSSS
<https://www.jpl.nasa.gov/news/nasas-curiosity-mars-rover-takes-selfie-with-mont-mercou>

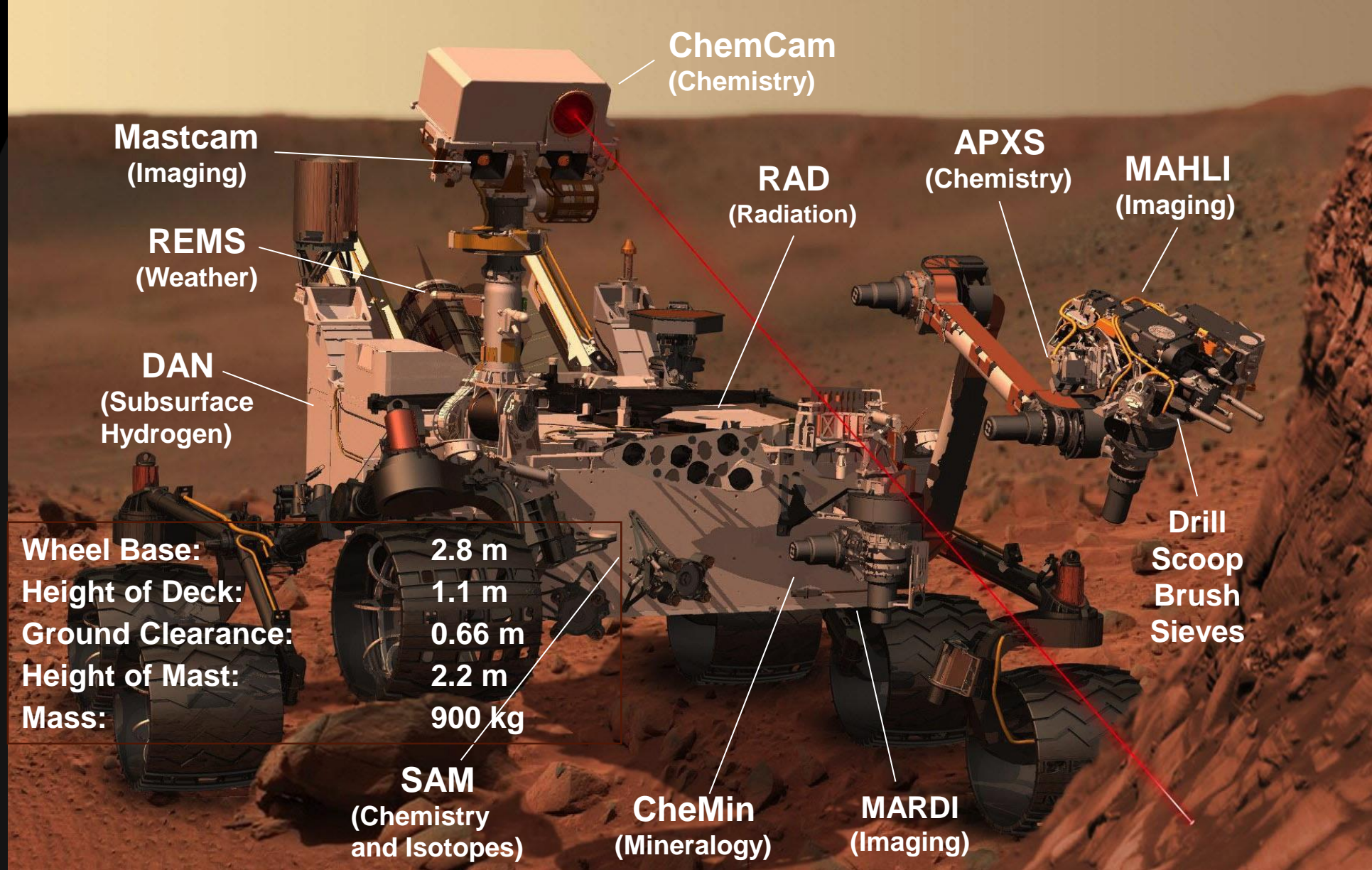

Curiosity's Science Payload



Goddard Space Flight Center

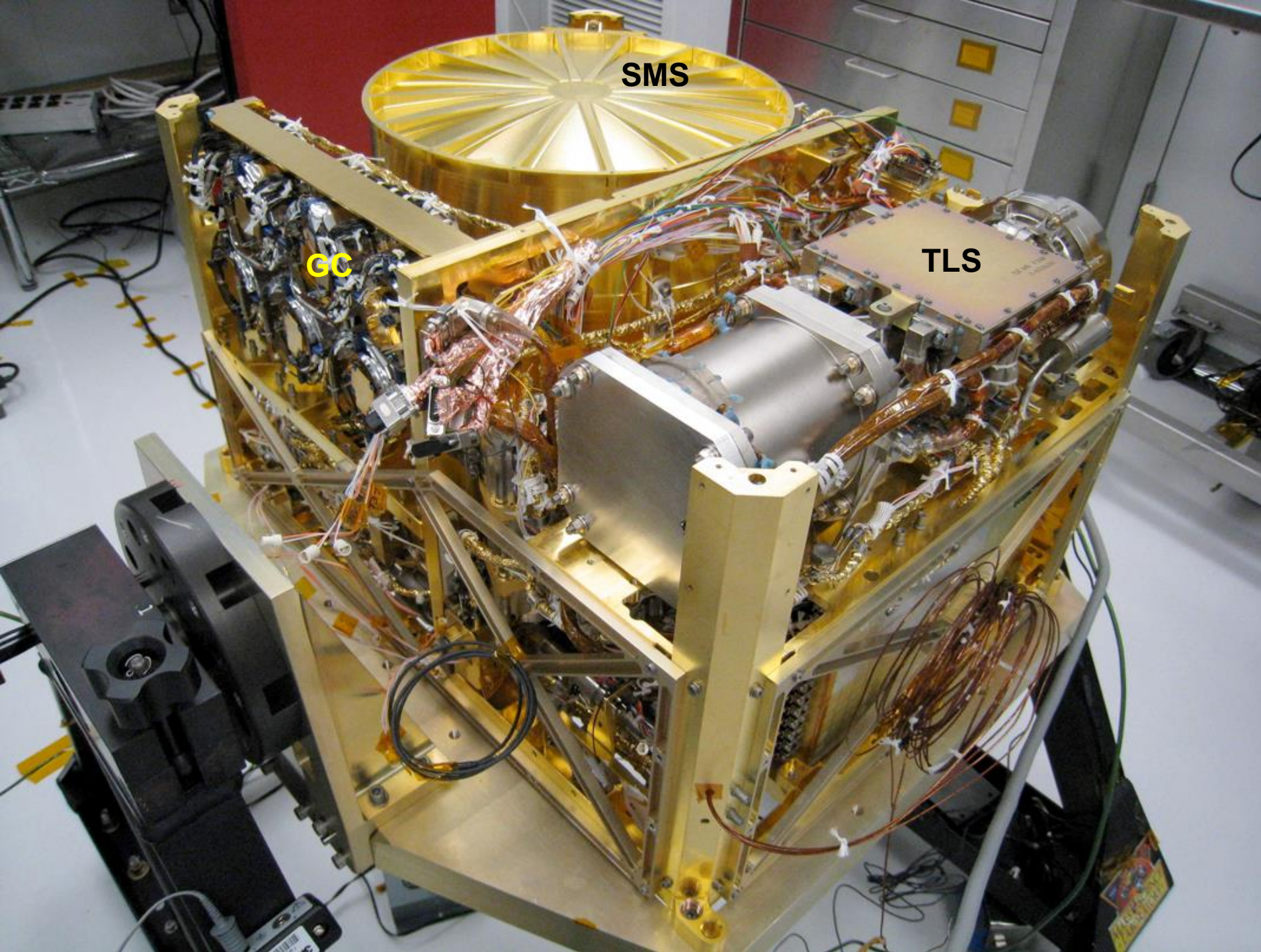

SMS

GC

TLS

Sample Analysis at Mars (SAM)



The Sample Analysis at Mars (SAM) Investigation

SAM suite instruments and major subsystems

- Quadrupole Mass Spectrometer
- 6-column Gas Chromatograph
- 2-channel Tunable Laser Spectrometer
- Gas Processing System
- Sample Manipulation System

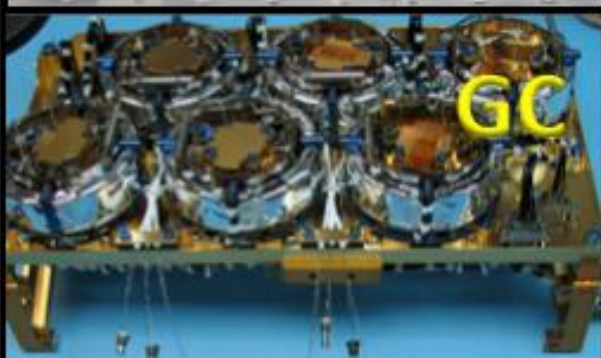
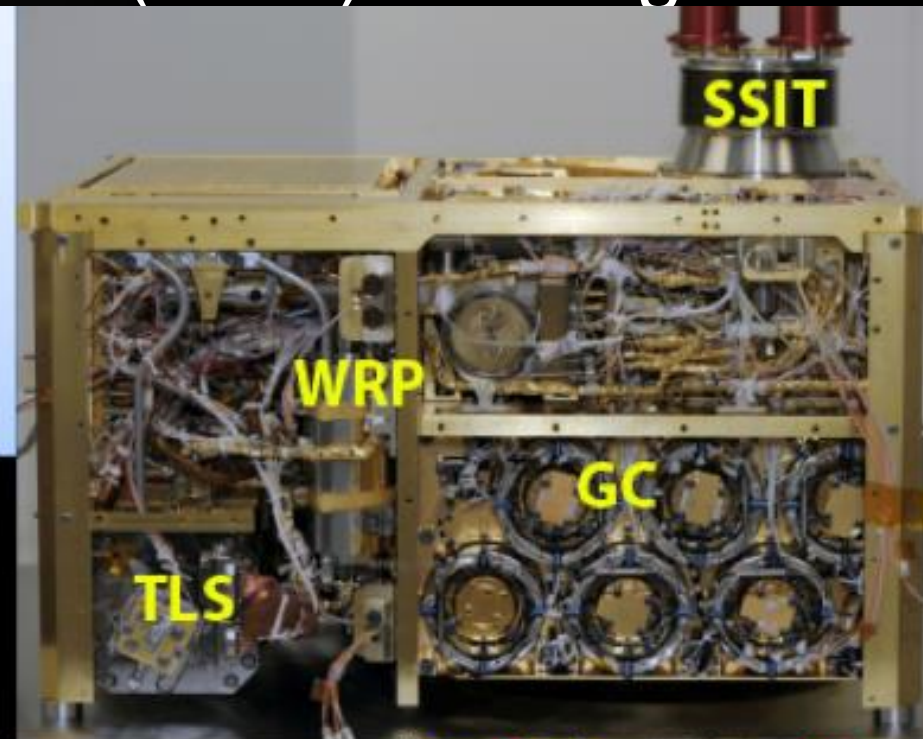

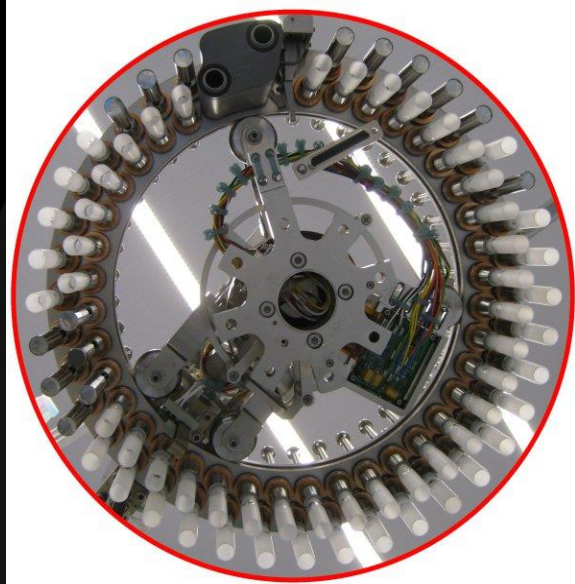

Powder from drill or scoop

SAM analyzes atmospheric gas or vapors extracted from solids for analysis in 3 instruments

SAM sample manipulation system



Oven

Gases are released as samples are heated in SAM's oven

He carrier gas for both EGA and GCMS

Measurement order for typically

- EGA with QMS
- TLS
- Combined GC and QMS

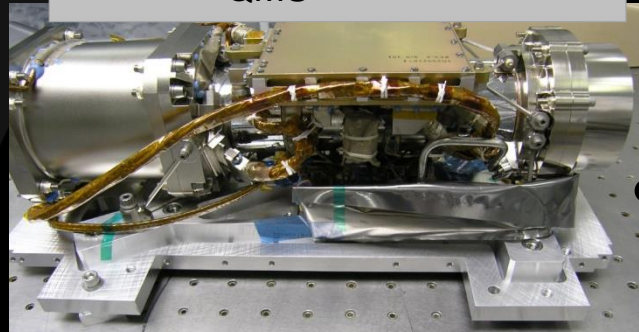

Mass spectrometer (QMS)

Gas chromatograph (GC)

Hydrocarbon trap

Tunable laser spectrometer (TLS)

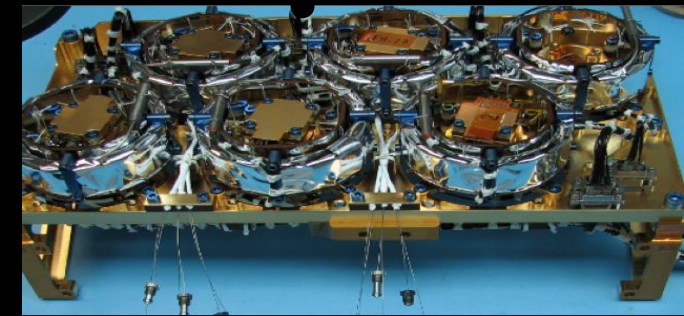



Engineering Thoughts

- All of the equipment launched in the all the years in the history of the space program equates to less than 1 day of worldwide auto production
- Behind the scenes: a lot of hard work
 - Great leadership
 - Teamwork
 - Forward thinking architecture – hardware and software
 - Testing and re-testing, redesign, more testing



Scope of challenges

- Pack a labful of science instruments, plumbing, and pumps into a box the size of a microwave oven
 - Challenging Technical constraints
 - Challenging Power and Energy budget
 - Challenging Thermal conditions
 - Challenging Schedule
 - Dispersed Across 10 time zones and multi-cultural and multi-institution teams
 - Challenging operational conditions
 - Survive launch, cruise, landing
 - 2 Earth year operational time
 - Challenging Conops (limited communications, terrain challenges)

Designing for Space Flight to Mars and Mars Ops



Launch environment and Mars Orbit Insertion

- Vibration
- Acoustics

Cruise Conditions

- Thermal considerations
- Spacecraft charging
- Radiation Environment
- Communications

Operations conditions

- 687 earth days operational life
- Power limitations
- Thermal constraints
- No repairability
- Operations last up to 15 hours
- Communication limitations
- Radiation
- Low pressure (7 Torr)
- CO₂ environment
- Low gravity
- Planetary Protection



VIBRATION Testing

The Vanguard 1, one of the first satellites ever launched into orbit and the oldest satellite still orbiting Earth, was tested on a vibration table built by Team Corporation in the late 1950s, shown in this picture. Innovations incorporated into those early devices are still used to this day.

Credits: Team Corporation



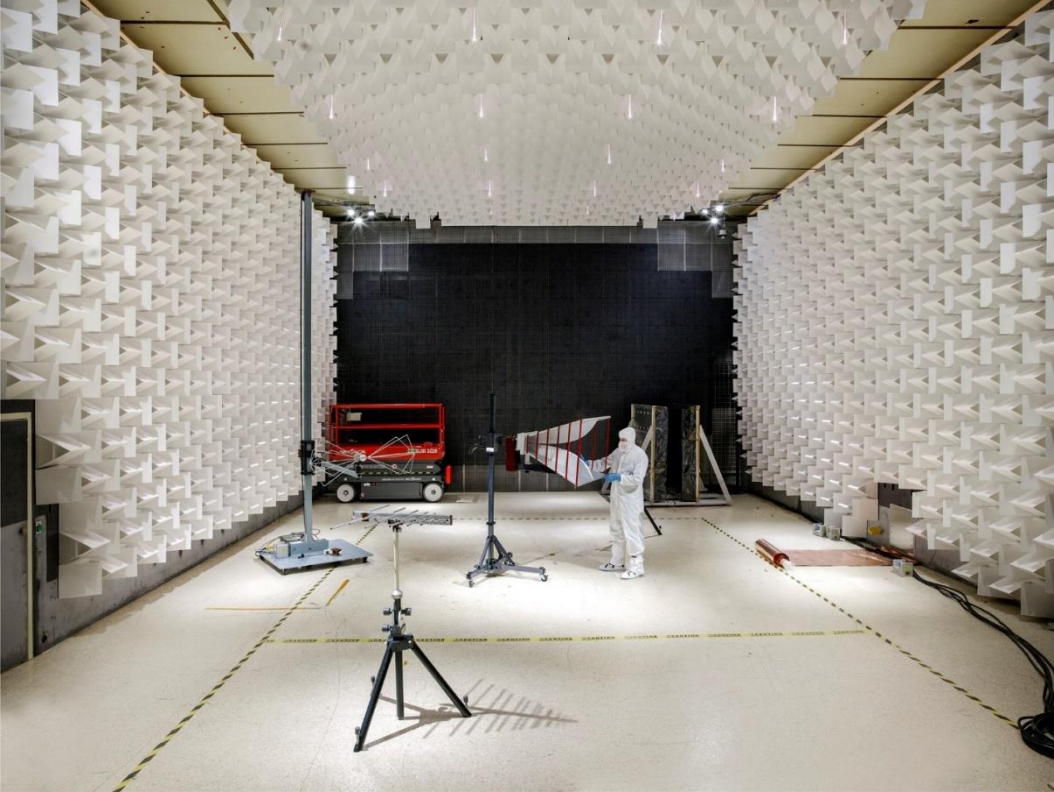

MIL-STD Radiated Emissions

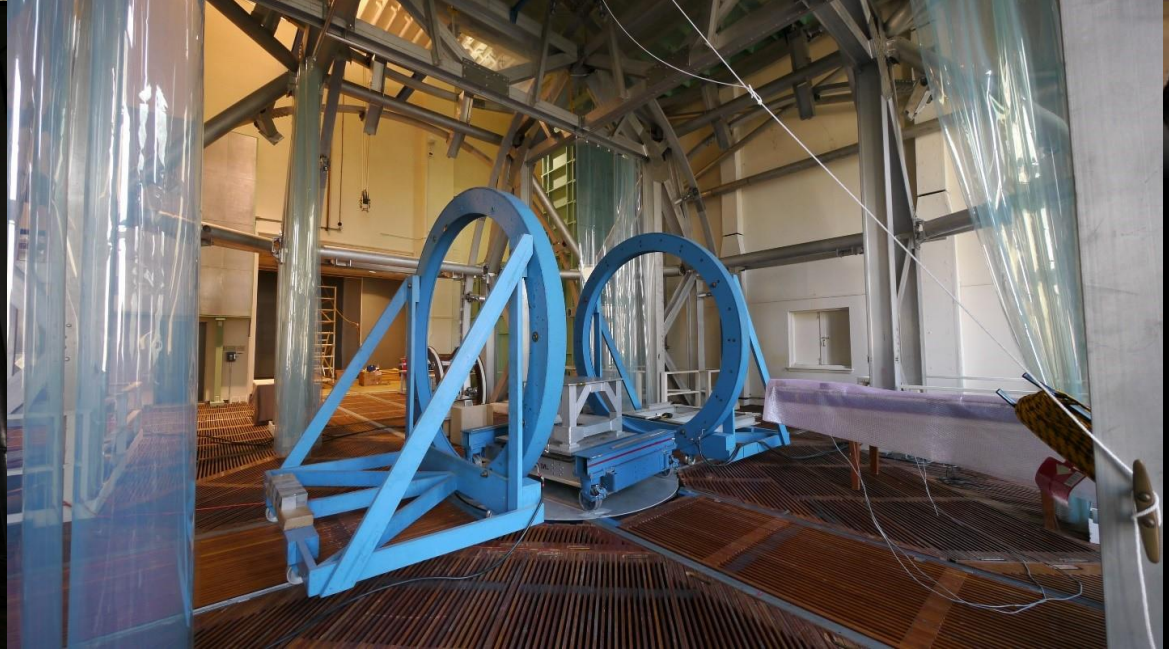
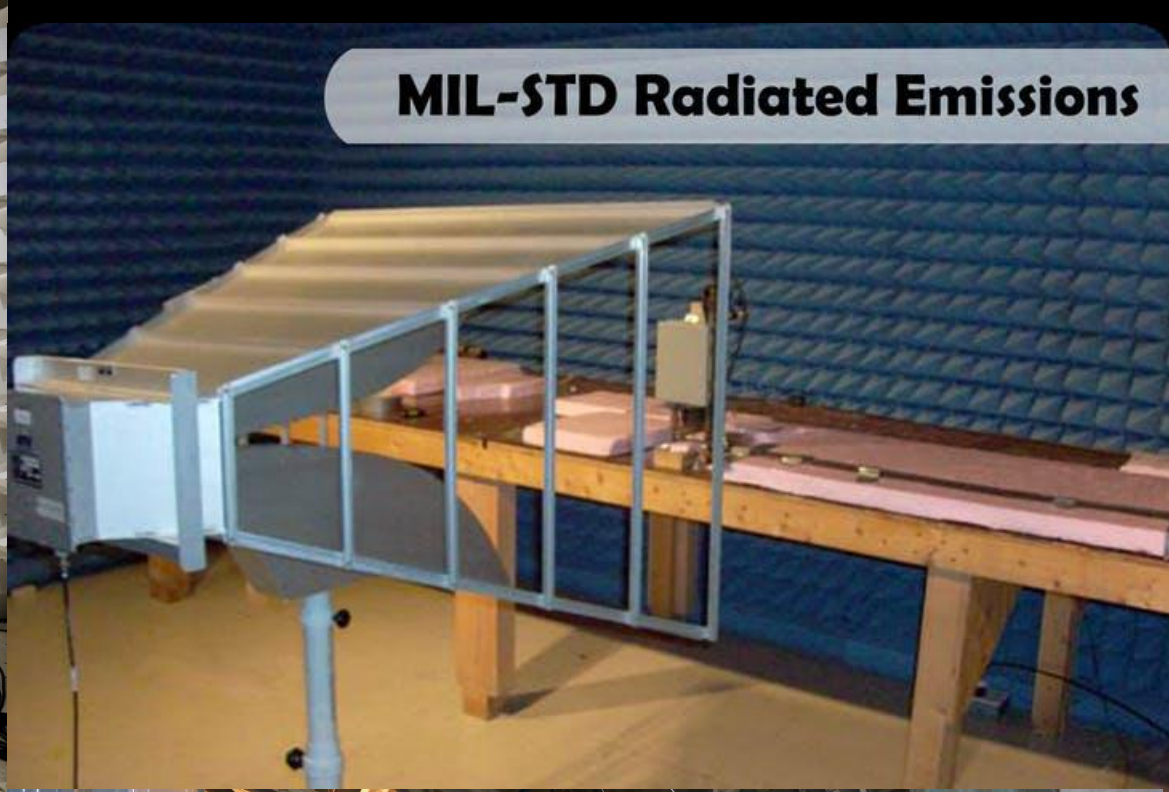



Thermal
Testing SAM

SAM



- 1071 vacuum interfaces
- 756 EB Welds
- 146 Braze Joints
- 125 Platinum O ring interfaces
- 40 C Seal Interfaces
- 4 Pinch off seals
- 40 electrical harnesses, 2000 feet wiring, 1200 solder

- Quadrupole Mass Spectrometer
- Tunable Laser Spectrometer
- 6 GC Columns
- Sample Manipulation System
- Electronics stack
 - 600 m wires, 1200 wires
- Software
- Sample Processing System
 - 74 Cups
 - Wide Range Pumps 100krpm
 - Gas Lines heated by 100 heaters
 - Valves to control gas flow
 - Hydrocarbon trap (-61C to 400C)
 - Pyrolysis Ovens (1100C)
 - 14 gas processing system Manifolds
 - 2 high conductance valves
 - 52 microvalves
 - 51 gas line heaters
 - Combustion and calibration gas
 - 2 Scrubbers and 2 getters
 - 2 He Tanks @ 2400psi
 - 4 heat pipes
 - Solid Sample Inlet Tubes
 - Thermal Shields



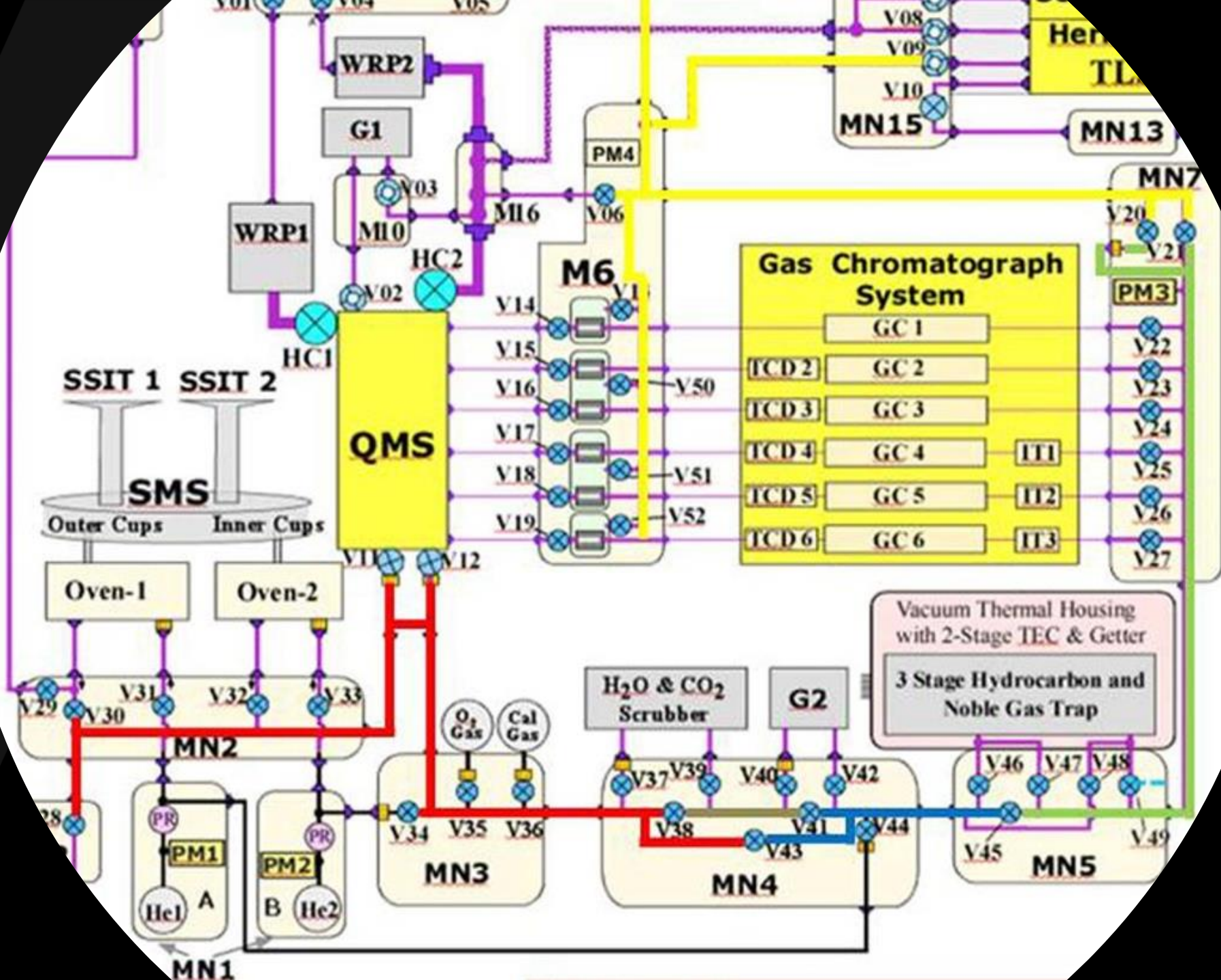

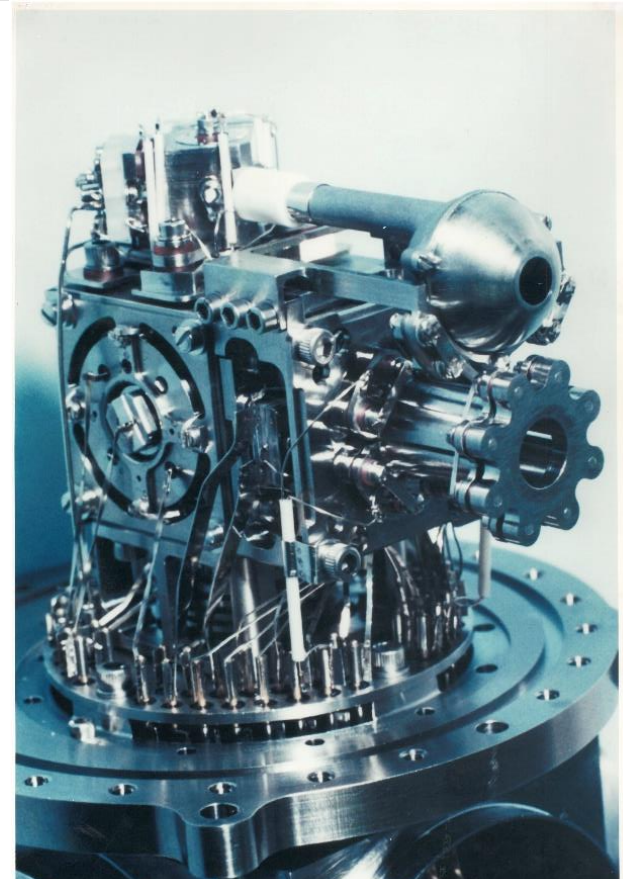
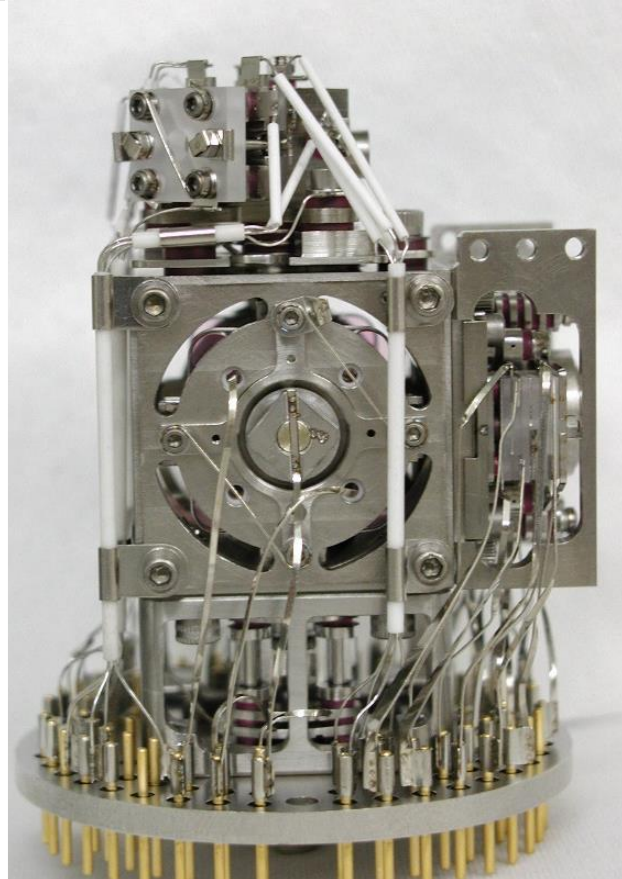
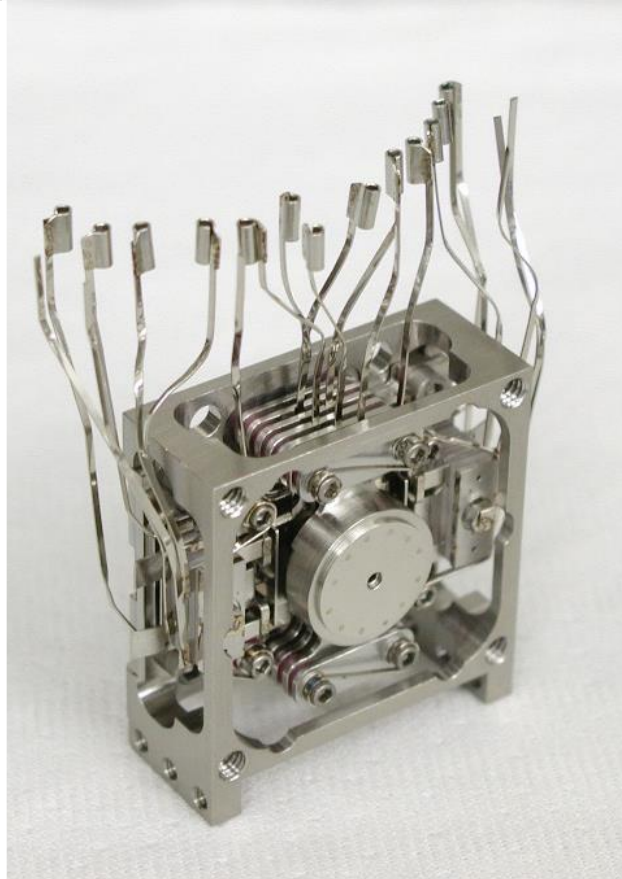
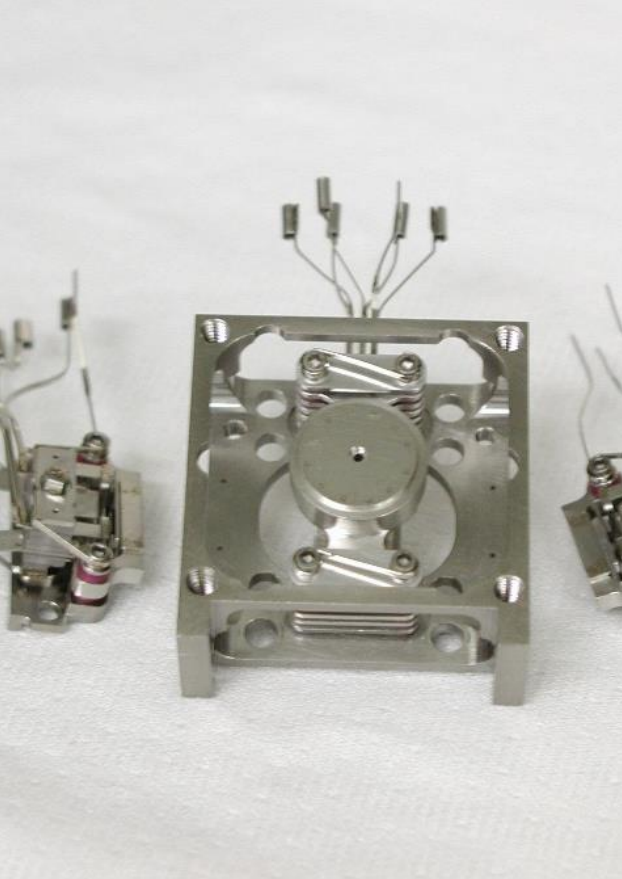

Quadrupole Mass Spectrometer parts

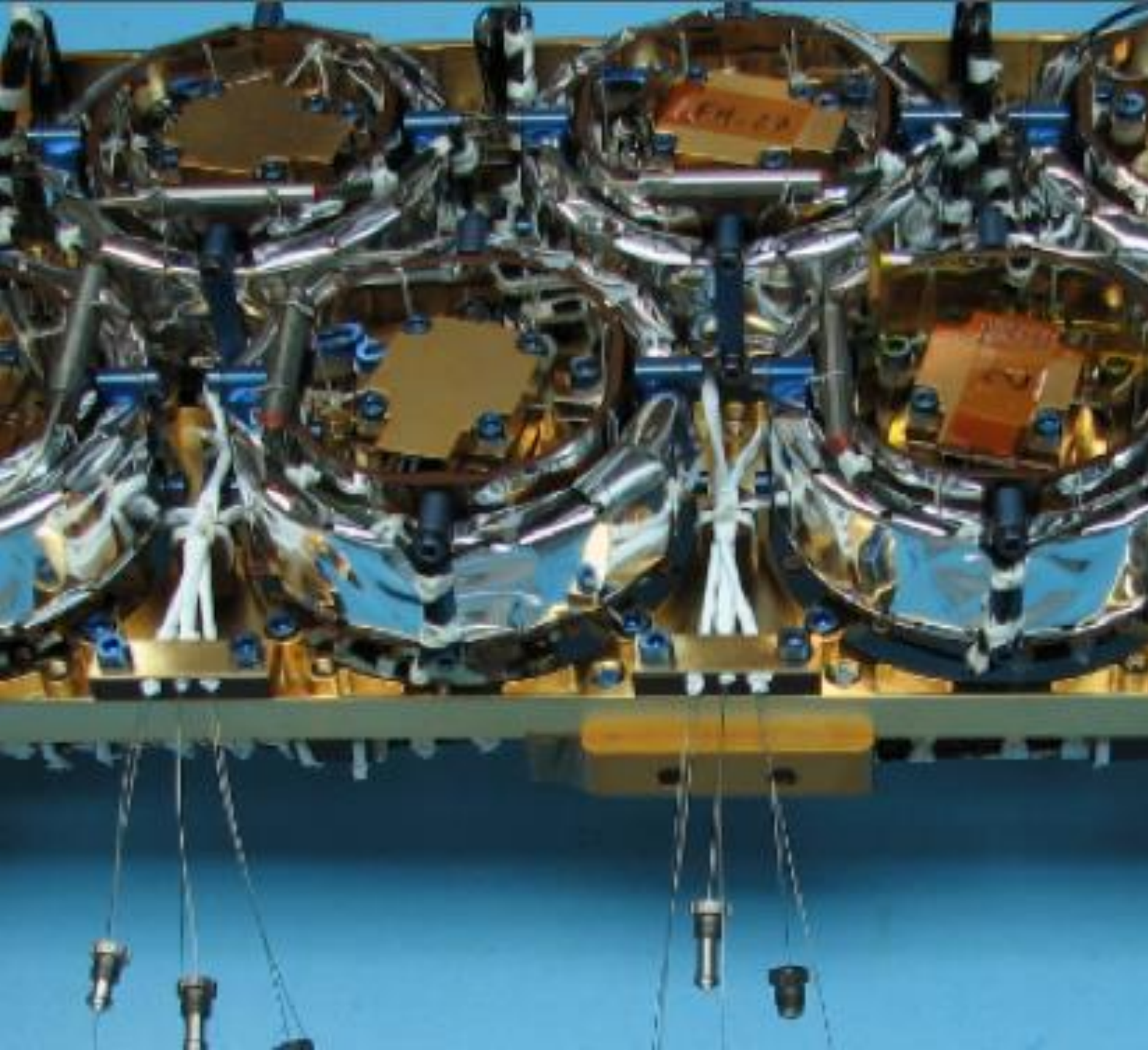

Gas Chromatograph



Gas
Chromatograph
Column repair

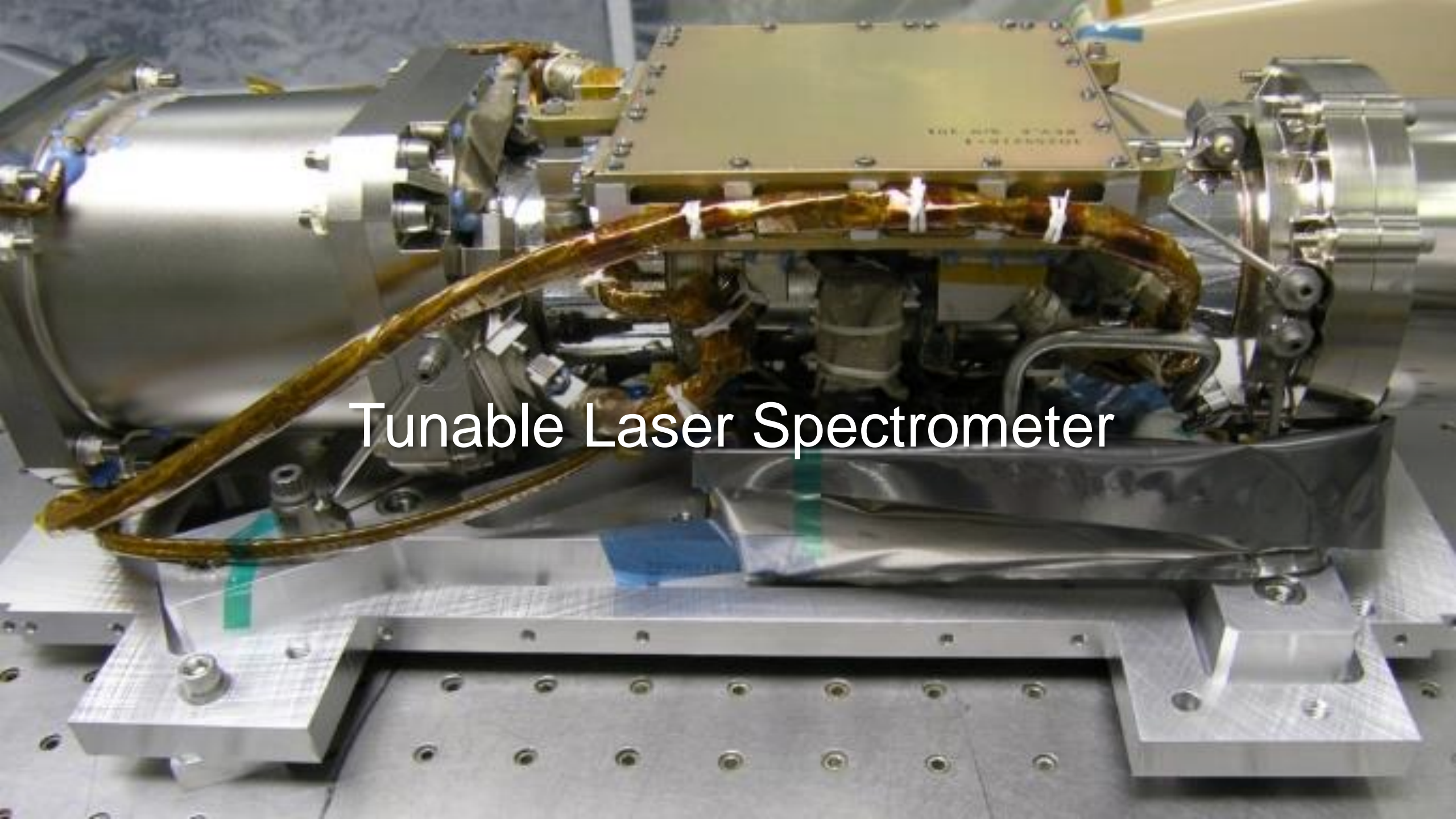

Tunable Laser Spectrometer

Trap Switch

29

Bi-metallic switch to switch Thermo Electric Cooler (TEC) contact off in the hydrocarbon trap when flash heater heats $> 100\text{C}$

Gold Plated Rotor
(spins at 100k rpm)

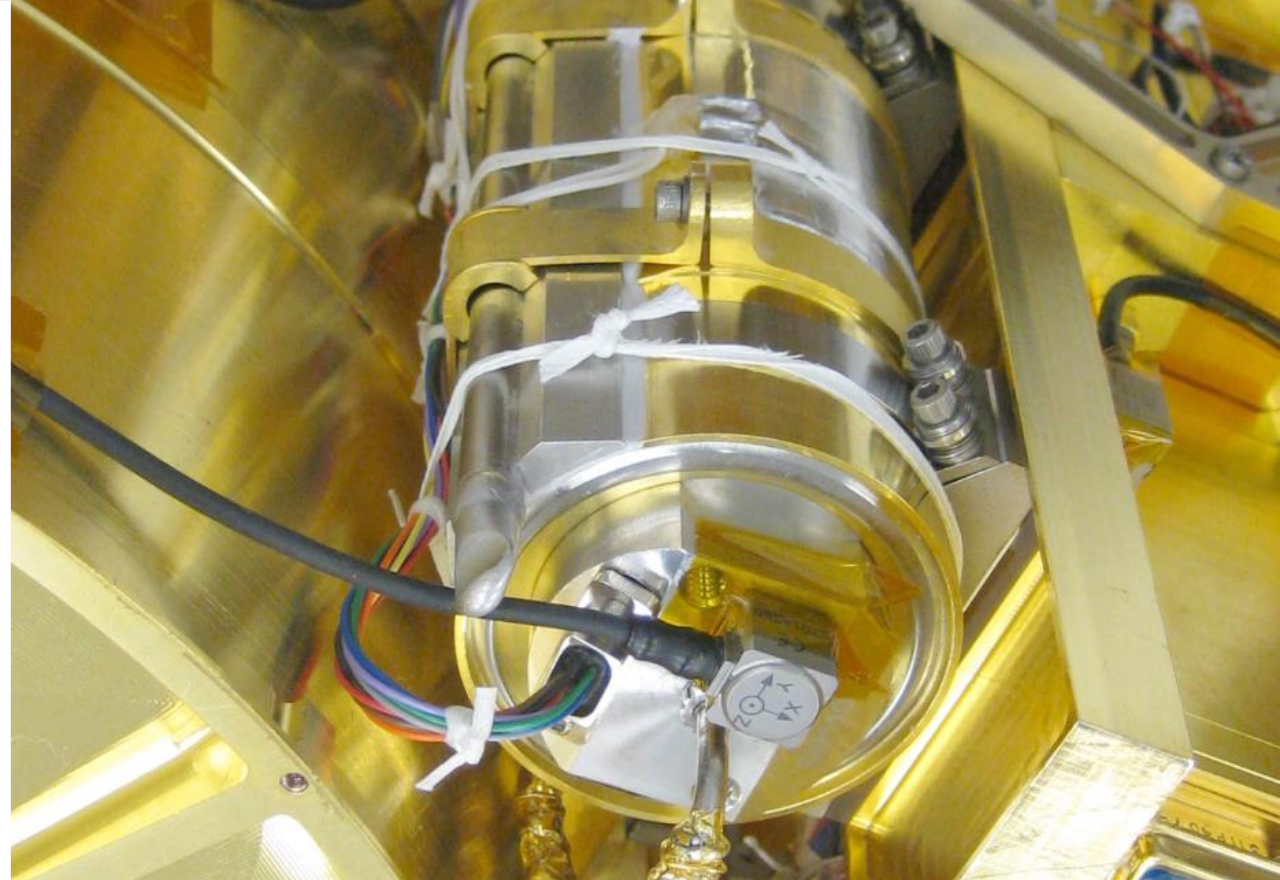
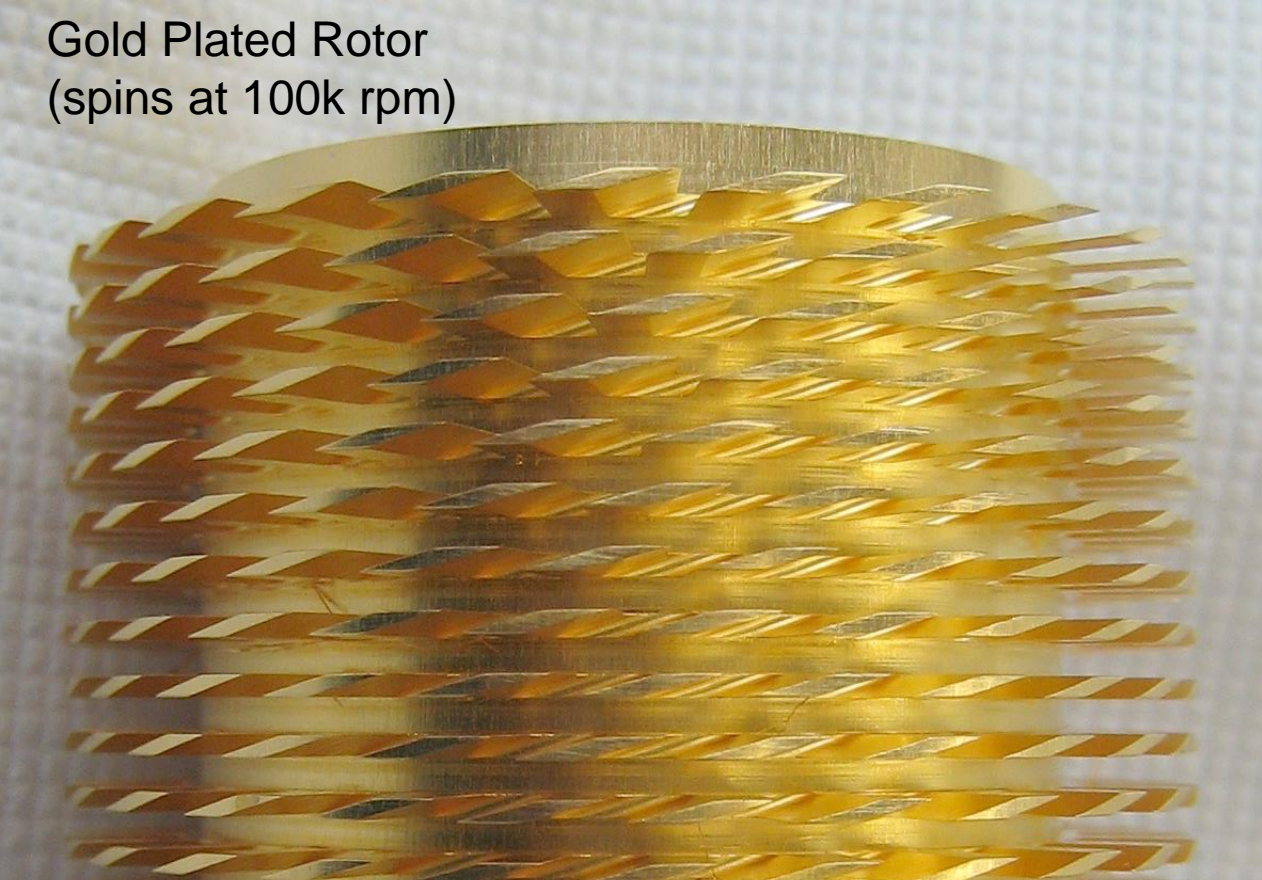

Wide Range Pump (WRP) Lifetime Issues

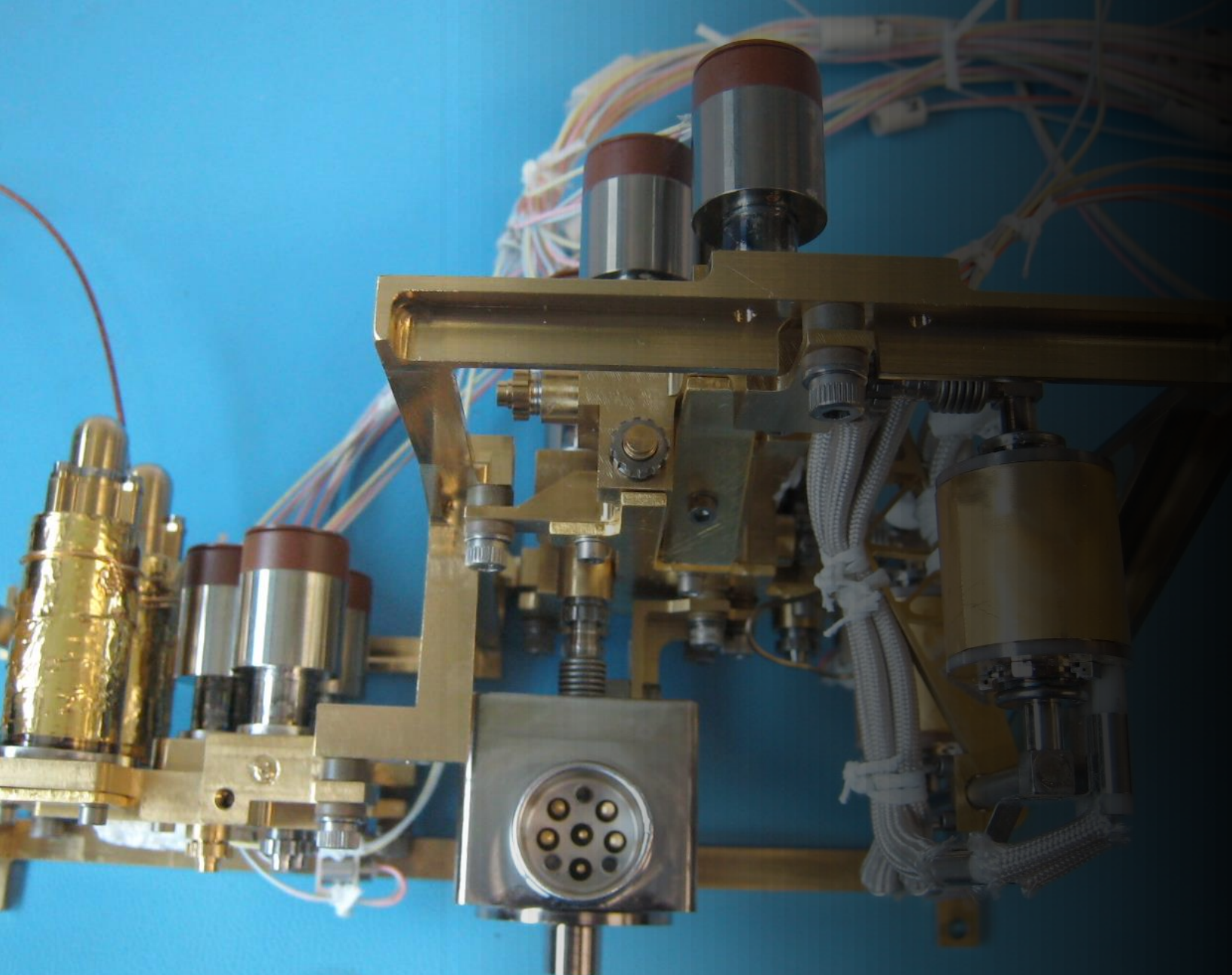

Microvalve
Installation and
Availability

Plaque on SAM Panel

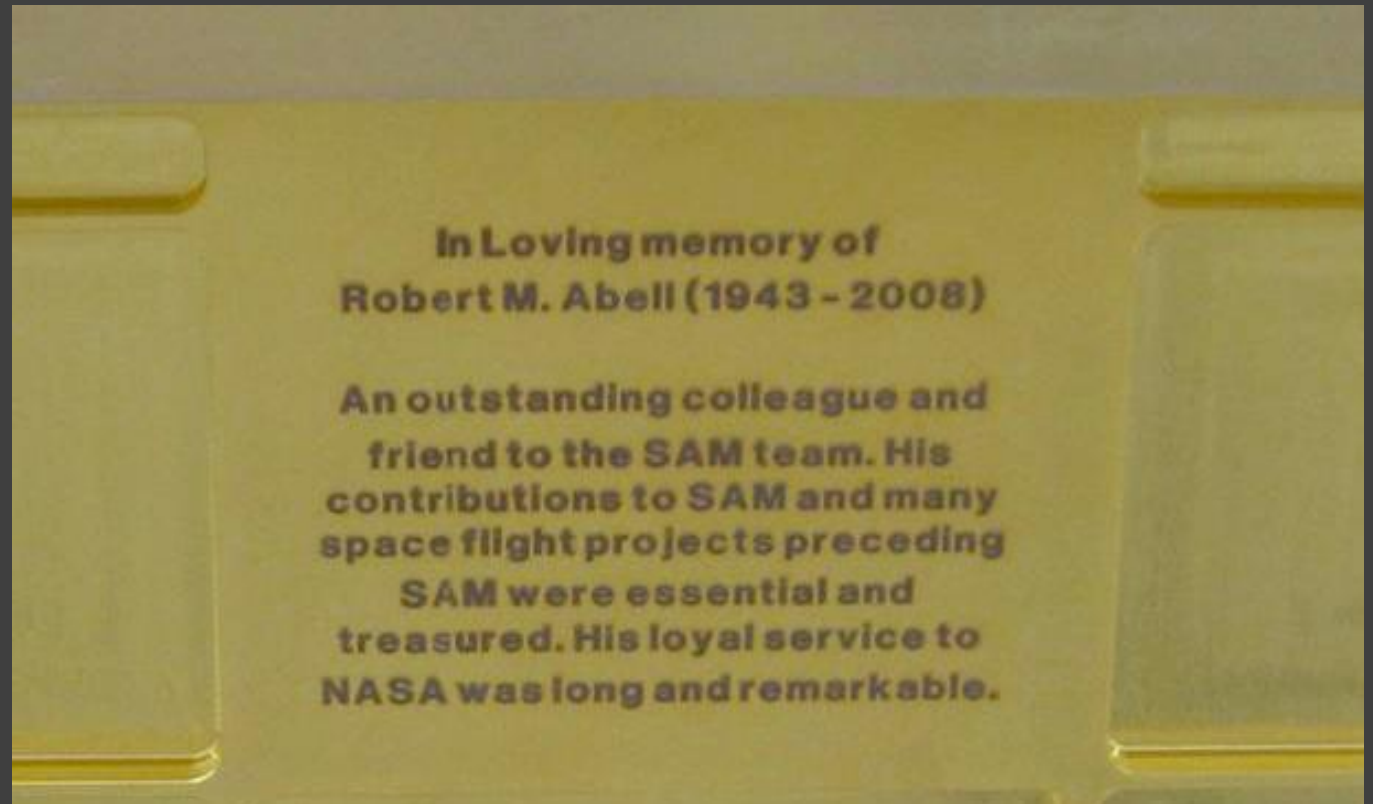



Helium
Reservoir Leaks



First Turn-on of
Quadrupole
Mass
Spectrometer
(QMS) – a Major
Milestone

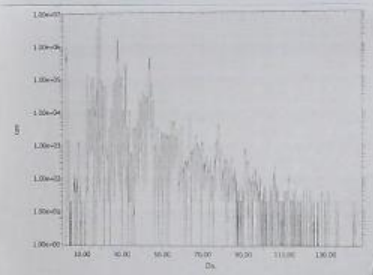

A QMS IS BORN!!
* FLIGHT MEB
* FLIGHT QMS
MARS OR BUST

CAUTION
SAFETY
Space
Hazard

Showing off the first QMS Spectrum

A close-up photograph of a complex electrical wiring harness. The image shows a dense bundle of multi-colored wires (red, yellow, green, blue, black, white, orange, purple) entering a brass terminal block on the right side. The wires are bundled together with white zip ties. The terminal block has several screw terminals, some of which are occupied by the wires. The background is dark and filled with more wires and components, suggesting a complex electronic assembly.

SAM's Harnesses



Tight Mechanical fit – every bit of space is taken



SAM integration



—

Rework to fit extra power busses and switches





QA on the job



SAM Integration into Rover at Jet Propulsion Laboratory Jan 2011



SAM
integrated
into rover at
JPL January
2011



Rover Testing @ Kennedy Space Center (KSC) June 2011



November 26, 2011 the Atlas V launch @ KSC

We Did It!!!





NASA/JPL-Caltech



Just after touchdown the next day



NASA/JPL-Caltech

Navigation camera image showing the surface scour marks and rocks on the rover's deck

Mars Sol (Day)



Mars rotates once every
24 hours, 37 minutes





Operation schedule

- 10:00 – Receive Data From Rover
- 11:30 – Science Team Gathers to Report Status
- 12:30 – Put together plan for tomorrow
- 15:30 – Meet again to verify plan works
- 19:30 – Review each detail of the plan
- 24:00 – Uplink the data



Operations

- First couple months, we had to tweak SAM yellow alarm settings
- Our limits were too conservative and caused SAM to “Safe” because we didn’t understand temperatures and pressures and operations on Mars

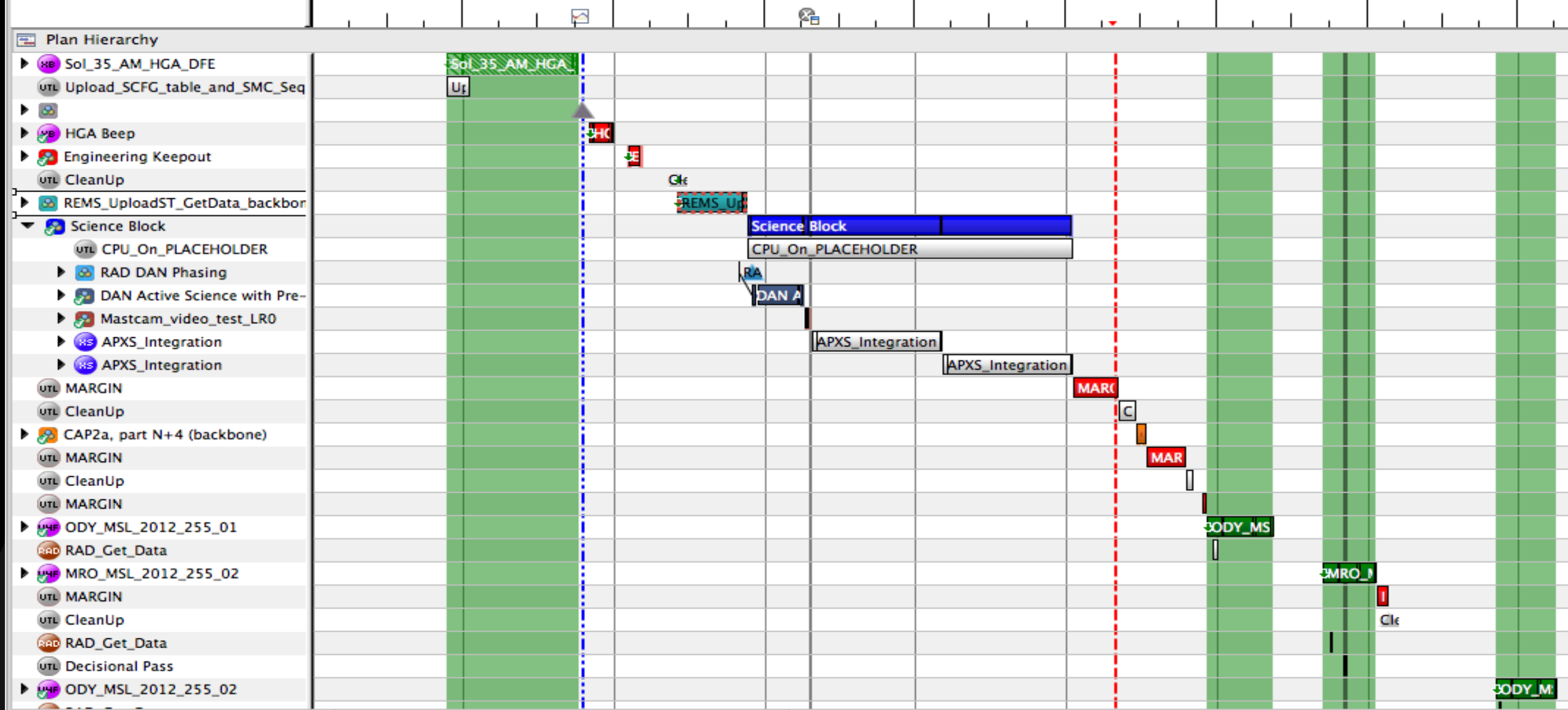

The Rover's Schedule

Commands to Curiosity



sam_11011.0000d.ENG_sms_commissioning_TEMPLATE sol00035_tap_apam:35-36 [READ_ONLY] AS_2.

```
1 # SAM SMS comissioning script for CAP1b - TEMPLATE
2 # TUL NOTE: the script file needs to be uplinked to /eng/payloads/sam/
3 # SYS-0040 waiver needed for use of constrained simplified-power command
4 # NOTE TO ROVER PLANNER - this sequence will leave mobility locked out by ACM
5 # for execution on sol TBD
6 # built in R10.5.6
7 SAM_EXPID_PRM_SETSAVDMP 76(priority) # ENTER THE CORRECT EXIPD FOR THIS SOL
8 SAM_POWER ALL_ON 33(priority)
9 SAM_SCRIPT UPLOAD_NEW_EXEC "/eng/payloads/sam/ENGsms_frV01.1" 0x
10 SAM_WAIT 2(min) ANY RUNNING_SCRIPT RUNNING_SCRIPT RUNNING_SCRIPT
11 SAM_WAIT 10(min) ANY READY READY READY # CHANGE TO CORRECT DURATION
12 SAM_SEND_TLM 33 95 # [duration 1000] ENTER THE CORRECT DURATION FROM ROADMAP
13 CMD_CONSTRAINT_OVERRIDE_PRIME
14 SAM_SIMPLIFIED_POWER ALL_OFF
15 # this activity ends with abort/safe complete flag NOT set
16 # this activity ends with "trashcan elevated" set - if successful
17 # for information only "experiment sequence complete" flag is NOT set
```

Commands to Curiosity are simulated

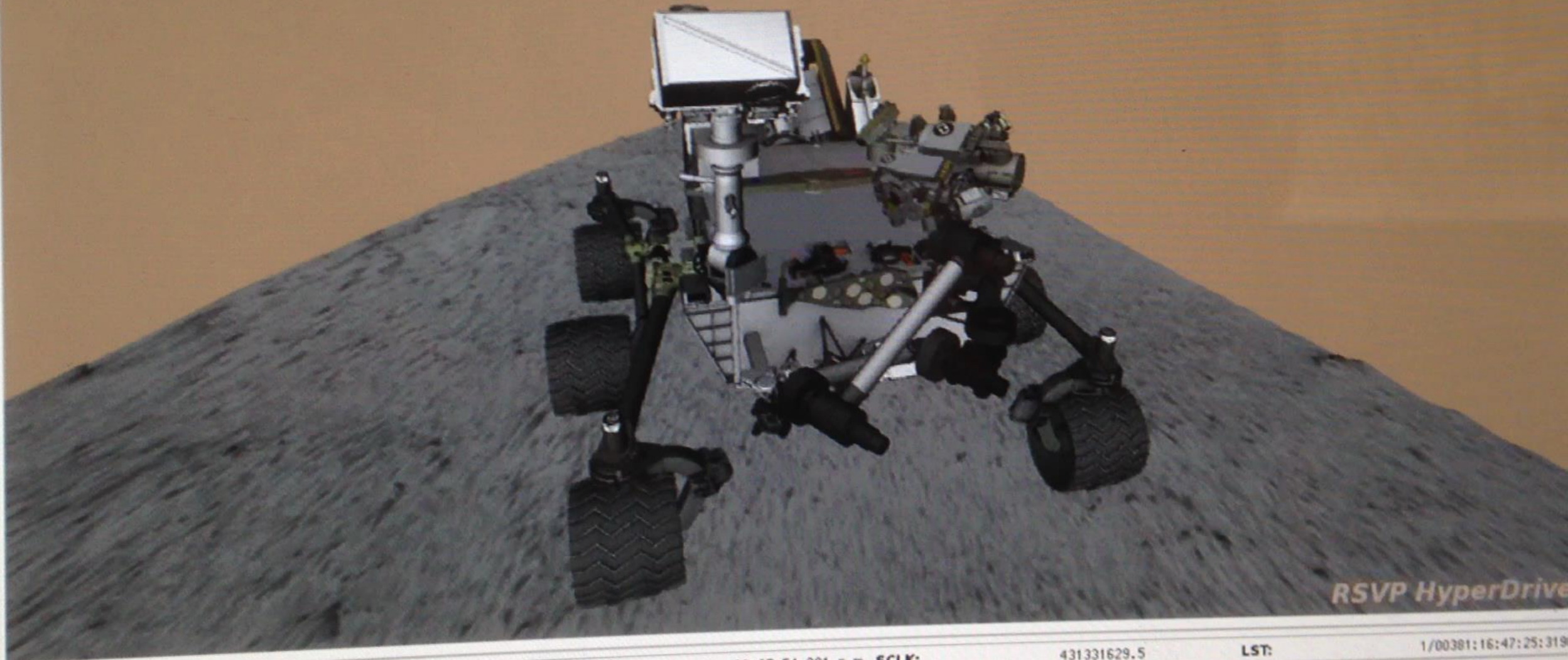

ET: 431332141.2 GMT: 2013 Sep 01, 06:27:54.001 p.m. SCLK: 431331629.5 LST: 1/00381:16:47:25:319

MCR Targets Overlay Kernels Rendering Sequences RKSM



We mistakenly measured Florida Air or “Flars” and thought we had discovered Methane on Mars

Martian Sunset





We need to try to do the right thing every time, to perform at our best, because we never know what moment in our lives we'll be judged on.

– Capt. Chelsey “Sully” Sullenberger

Curiosity is now on its way to study the Layers, Canyons, and Buttes of Mount Sharp

QUESTIONS?



CURIOSITY and SAM Status

