A detailed 3D rendering of the STAR-X satellite in space. The satellite features a large, circular, segmented primary mirror at the front, with various instruments and structural components visible behind it. The background is a dark field of stars, with some stars appearing as bright, multi-colored points of light. An orange horizontal bar is located in the top left corner of the slide.

# STAR-X: Survey and Time-domain Astrophysical Research Explorer

---

William W. Zhang

21 July 2022

# Survey and Time-domain Astrophysical Research eXplorer



EXPLORING THE FAST, FURIOUS, AND FORMING UNIVERSE

William W. Zhang, Principal Investigator  
Ann Hornschemeier, Deputy Principal Investigator

In response to NASA's Astrophysics Explorers Program 2021 Medium Explorer (MIDEX)  
Announcement of Opportunity – NNH21ZDA0180 - December 9, 2021

## *Science*

**GSFC:** Brad Cenko, Edmund Hodges-Kluck, Ann Hornschemeier, Craig Markwardt, Kim Weaver, William Zhang, **JHU:** Mihoko Yukita, **UMBC:** Antaras Basu-Zych, Kai-Wing Chan, **CFA:** Francesca Civano, **Howard:** Joel Coley, **INAF-Bologna:** Roberto Gilli, **McGill:** Daryl Haggard, **MIT:** Mark Bautz, Erin Kara, Michael McDonald, Eric Miller, **Northwestern Univ.:** Maya Fishbach, Wen-fai Fong, Vickey Kalogera, **Penn State Univ.:** Niel Brandt, **UCB:** Raffaella Margutti, **UCSC:** Ryan Foley, **Univ. of Colorado:** Brian Fleming, Kevin France, Sebastian Pineda, **Univ. of Utah:** Daniel Wik, **Univ. of Crete:** Andreas Zezas

## *X-ray Telescope*

**GSFC:** Michael Biskach, Kai-Wing Chan, Ryan McClelland, Raul Riveros, Peter Solly, Timo Saha, William Zhang  
**MIT:** Mark Bautz, Mark Egan, Robert Goetze, Eric Miller

## *UV Telescope*

**Univ. of Colorado:** Brian Fleming, Carl Gelderloos, Kevin France, Thomas Patton  
Jerry Jason (mission operations)

## *Spacecraft and Observatory*

**Ball Aerospace:** Daniel Miller, Michael Veto, Brian Woods  
**GSFC:** Henock Legesse, Matthew Marcus, Ryan McClelland

## *Science and Mission Operations*

**GSFC:** Craig Markwardt, **Univ. of Colorado:** Jerry Jason

# Exploring the Fast, Furious, and Forming Universe

## *The STAR-X Science Story*

**The FAST:** Locally rare, brief events have an outsized impact on the Universe.



The heavy elements needed for life are synthesized in and dispersed by supernovae and neutron star mergers. Similarly, a single stellar superflare can evaporate an ocean or catalyze prebiotic pathways. The STAR-X wide field UV/X-ray design and fast and flexible operations captures these events.

**The FURIOUS:** Black holes grow extremely rapidly at early times in the Universe and are critical to galaxy evolution.



STAR-X will uniquely probe the physics of rapid accretion that allowed massive black holes to grow so quickly in the early Universe. STAR-X will catch transient, extreme black hole feeding events, such as TDEs, where entire stars are disrupted.

**The FORMING:** Distant galaxy clusters provide maximal leverage in evolutionary studies of structure formation and chemical enrichment.



STAR-X will conduct deep surveys and discover the elusive diffuse emission from the largest bound objects in the Universe (clusters of galaxies), shortly after their birth. STAR-X's combination of excellent imaging and low particle background (due to orbit choice) makes this possible in a way that no other mission can.



# What's STAR-X?

## Spacecraft (SC)

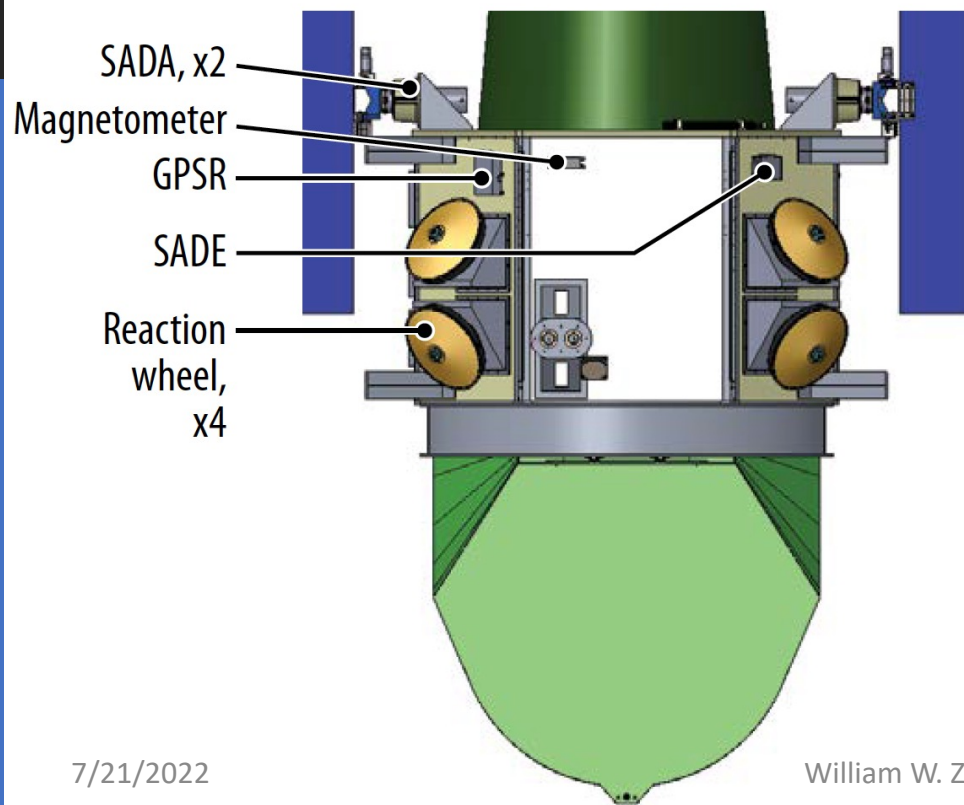

## X-ray Telescope (XRT)

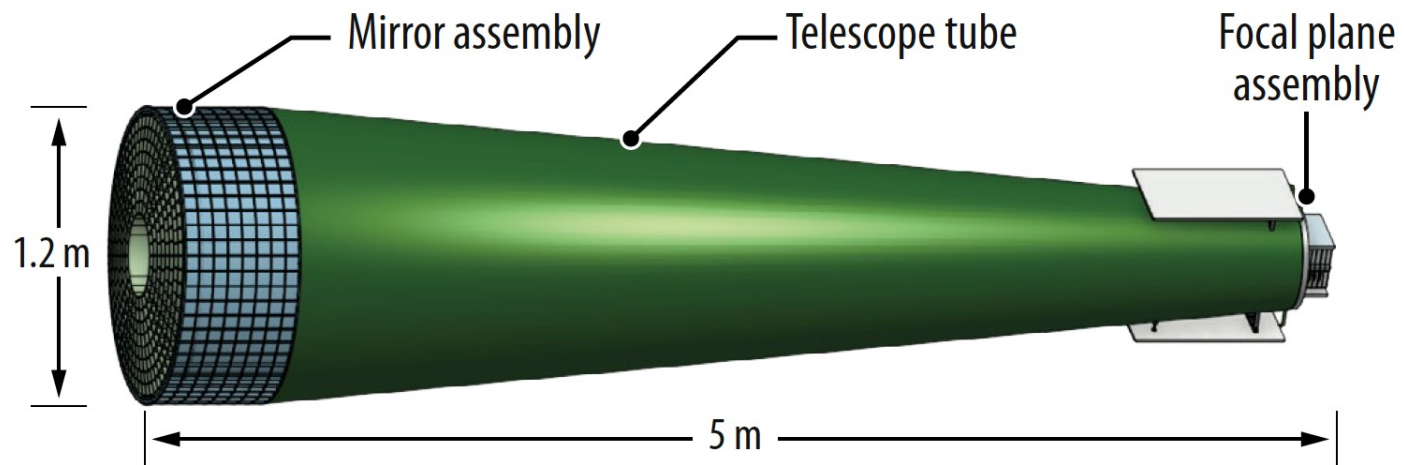

## UV Telescope (UVT)



# Key Features of the STAR-X Observatory

- Three largely independent subsystems: XRT, UVT, and SC
- Each independently built and qualified
  - XRT by GSFC+MIT
  - UVT by Univ. of Colorado
  - SC by Ball Aerospace
- Easy integration and testing: “plug and play”
  - Obs. Integration and testing by Ball Aerospace

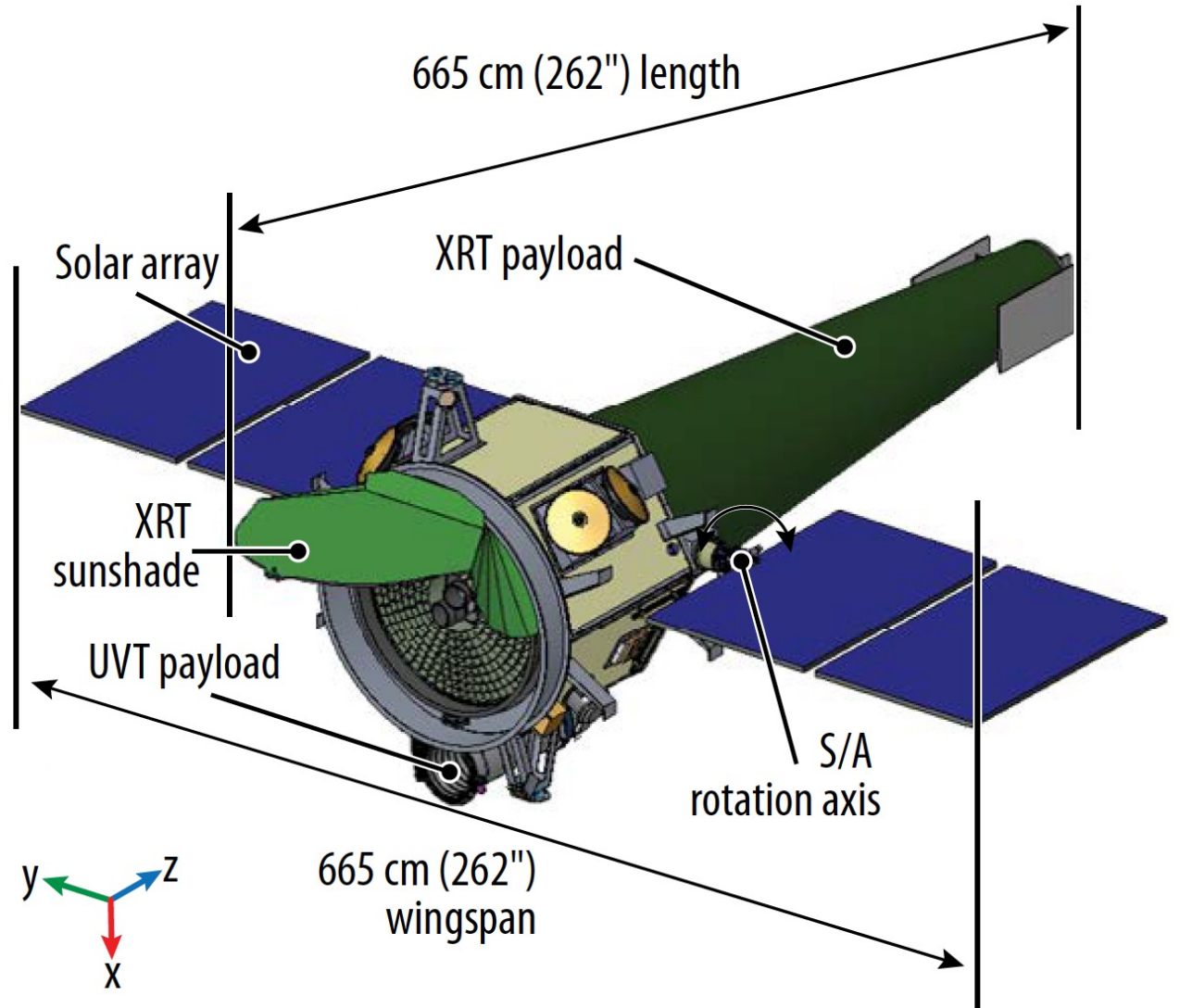

# Key Features of the X-ray Telescope

- Excellent PSF: 2.5" on-axis, 8" 0.5-deg off-axis.
- Large FOV: 1 deg<sup>2</sup>.
- Large effective area: >1,800 cm<sup>2</sup> at 1 keV.
- Low particle background.

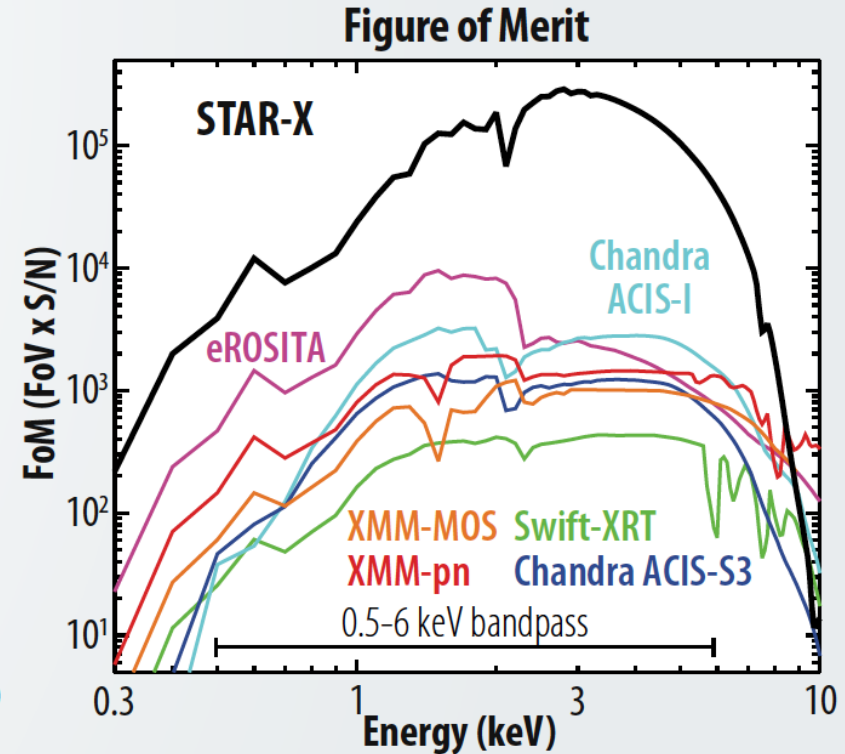
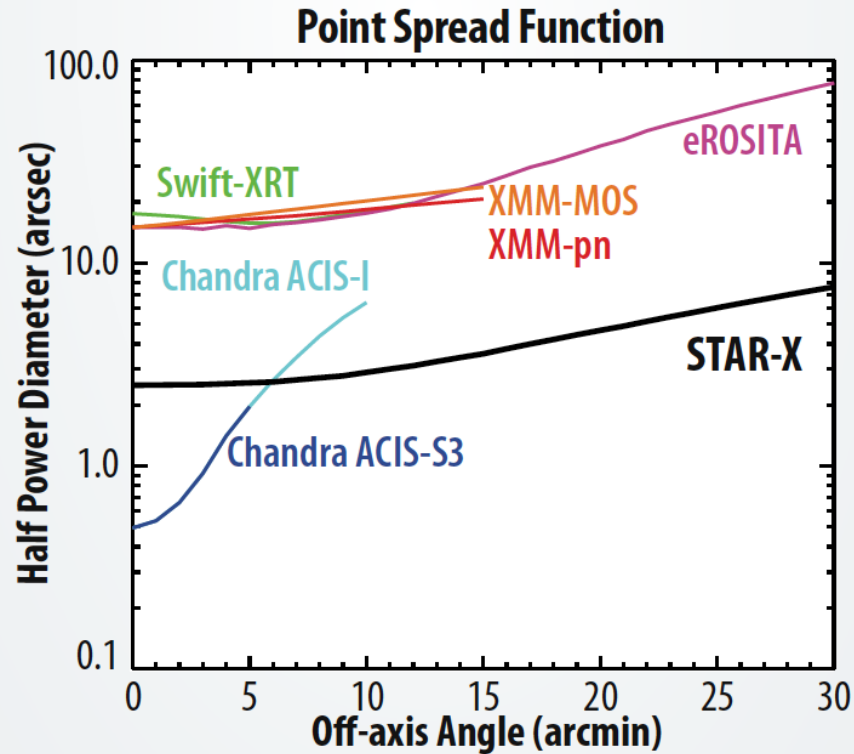
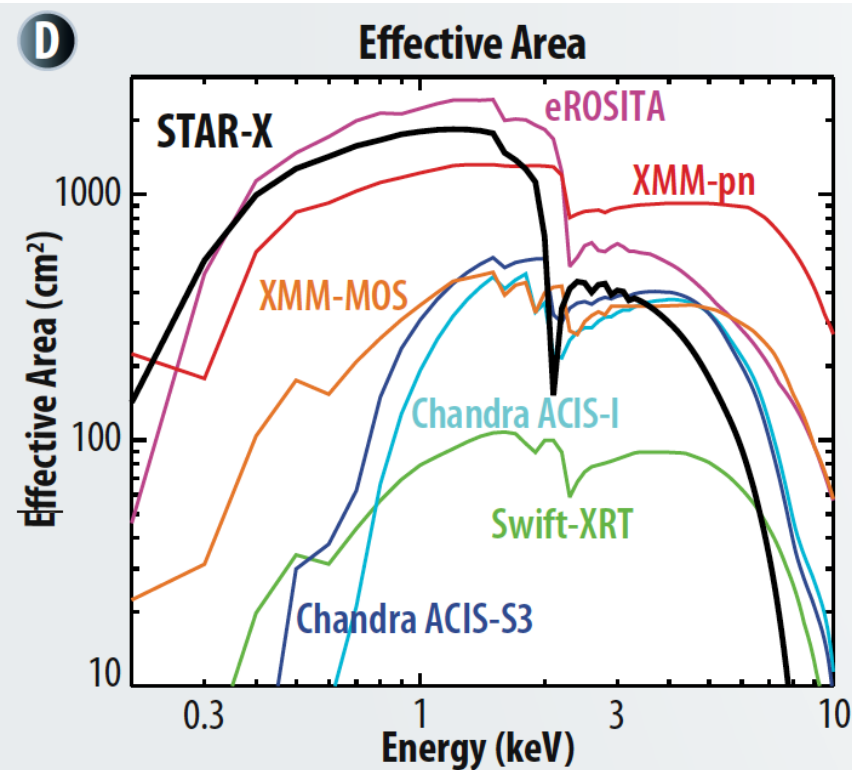

# Key Features of the UV Telescope

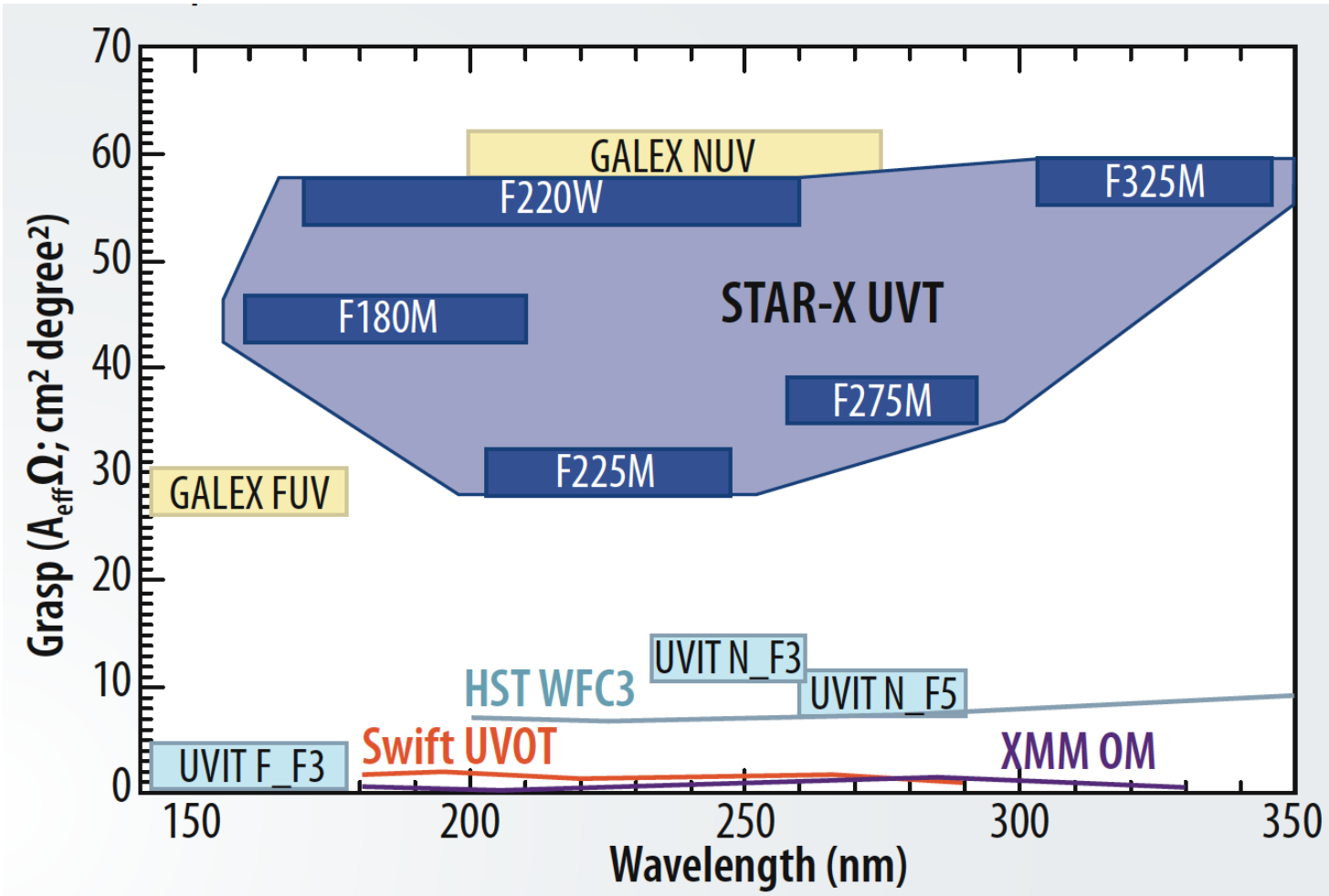

- Excellent PSF:  
4" on- and off-axis.
- Large FOV:  $1.0 \text{ deg}^2$ .
- Good effective area:  
 $25 - 55 \text{ cm}^2$ .
- Five filters
  - 180 nm
  - 220 nm
  - 225 nm
  - 275 nm
  - 325 nm

# Key Features of the Spacecraft

- **Three-axis Stability and Short Settle Time**

- Supports the excellent PSF of XRT and UVT
- Enables efficient raster scans

- **High Degree of Autonomy**

- Can protect itself and instruments
- Enables efficient operations

- **Fast Slew**

- Fast response to ToO
- High observing efficiency

- **Fast And Real-time Communication To Ground**

- Uplinks triggers from other observatories
- Downlinks information of new transients

- **Large Data Storage**

- Enables observation of bright sources

- **No Consumables**

- Mission can last far beyond the two year prime mission

# Fast Response to TOO: <120 mins, 90% of the time

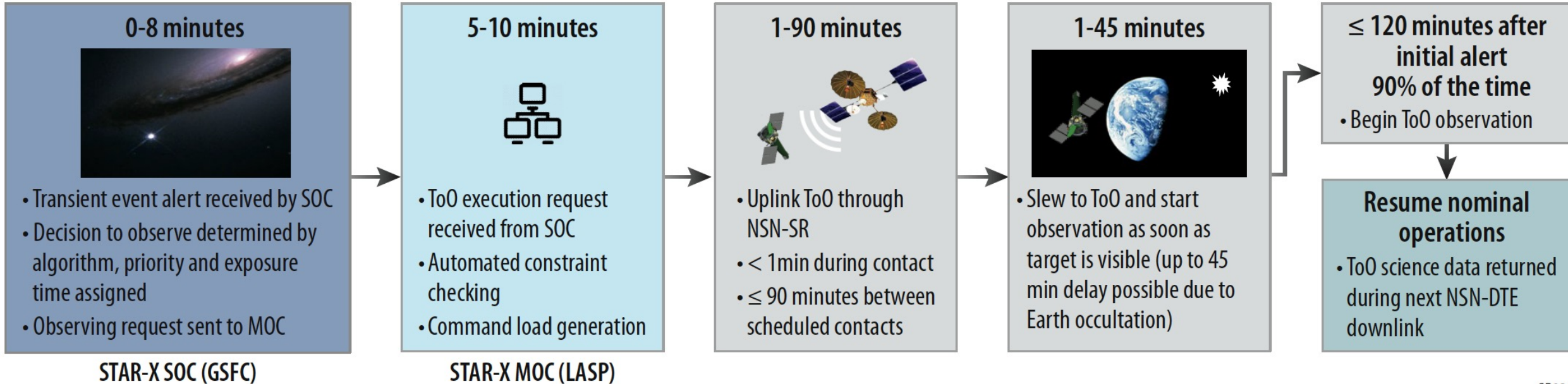

- Algorithmic selection of ToO for STAR-X to respond to.
- Scheduled command uplink windows to minimize response time.
- Near real-time downlink information of transients detected by STAR-X

# Science Program for the Two Year Prime Mission

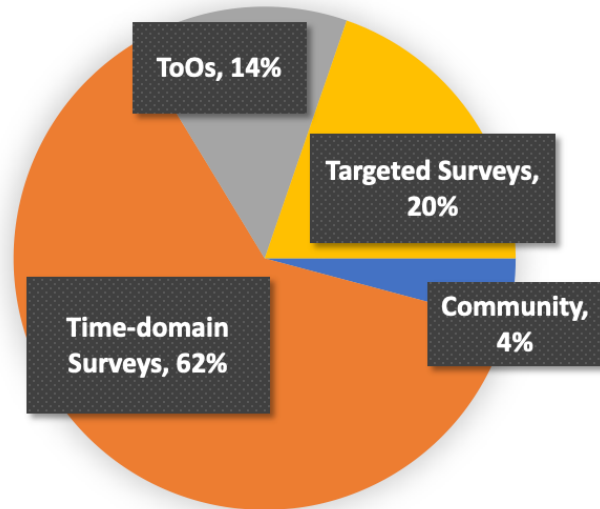

## • Time Domain Surveys

- Deep survey: Rubin deep drilling fields
  - 12 deg<sup>2</sup>, **Daily Cadence**
  - $1 \times 10^{-14}$  cgs (X-ray) and 22.5 mag (UV)
- Medium survey: Stripe 82 + Subaru fields, & Rubin deep drilling fields
  - 300 deg<sup>2</sup>, **Weekly Cadence**
  - $3 \times 10^{-14}$  cgs (X-ray) and 22.3 mag (UV)

## • Targets of Opportunity

- Young supernovae
- GW X-ray/UV counterparts
- GW source late-time follow-up
- Tidal-disruption events

## • Targeted Surveys

- 10 nearby galaxies
- 9 low-mass, planet-bearing stars
- 20 high-z SZ-detected clusters
- 20 nearby clusters

## • Community Program

- Impromptu requests from the broad community

# Time-domain Surveys

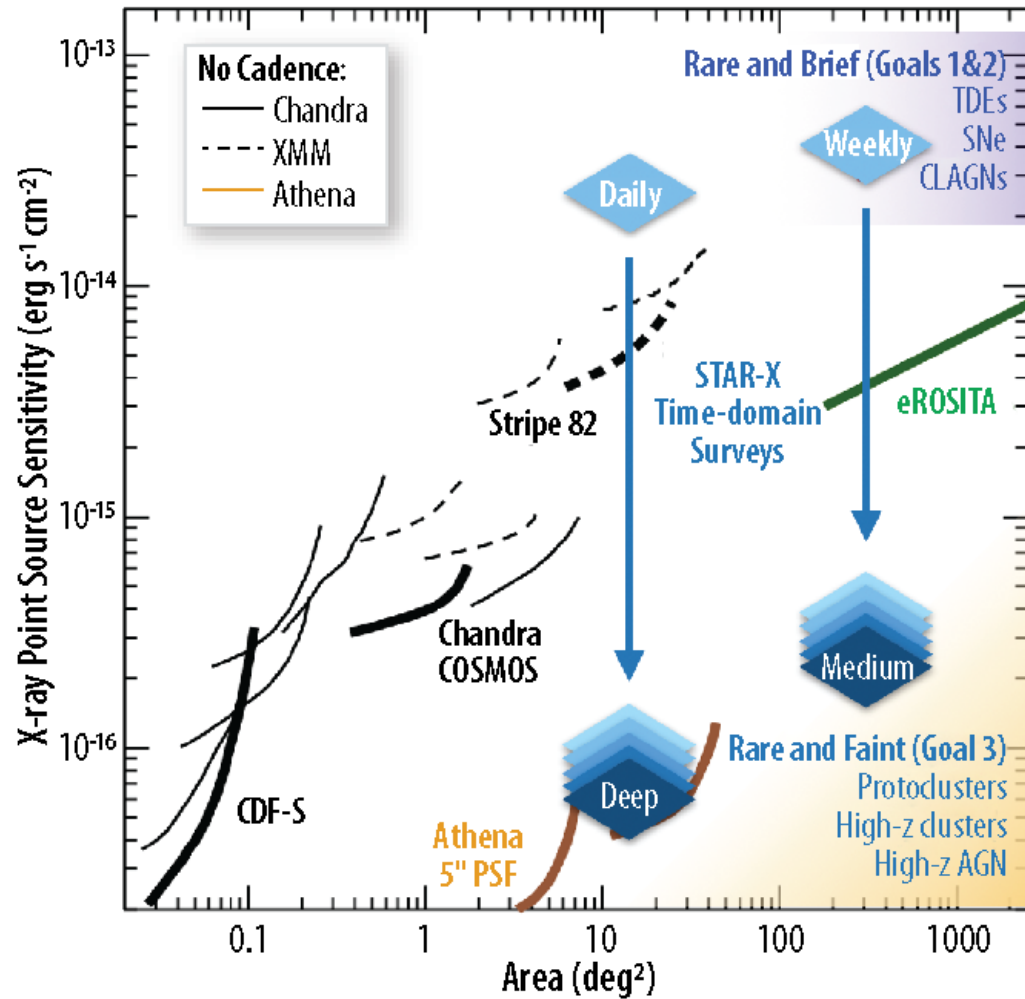

<p><b>1-1 Supernovae</b></p> <p>XRT discovers a shock breakout and triggers a ToO to catch cooling in the UV</p>	<p><b>2-1 Tidal Disruption</b></p> <p>Weekly X-ray/UV monitoring rapidly reveals hundreds of new TDEs</p>	<p><b>2-2 AGN Accretion Flows</b></p> <p>Daily X-ray/UV monitoring probes accretion disk structure via time lags</p>
<p><b>3-1 Protoclusters</b></p> <p>STAR-X will witness the birth of galaxy clusters at <math>z &gt; 3</math> via AGN clustering and early intracluster medium</p>	<p><b>3-2 High-z Clusters</b></p> <p>STAR-X will discover hundreds of high-z clusters to trace cluster growth over cosmic time</p>	<p><b>Survey Science: <math>z &gt; 6</math> AGNs</b></p> <p>STAR-X surveys high-z AGNs 64x faster than Chandra with a better FOV-averaged PSF</p>

SR024

# Study of Core Collapse Supernovae

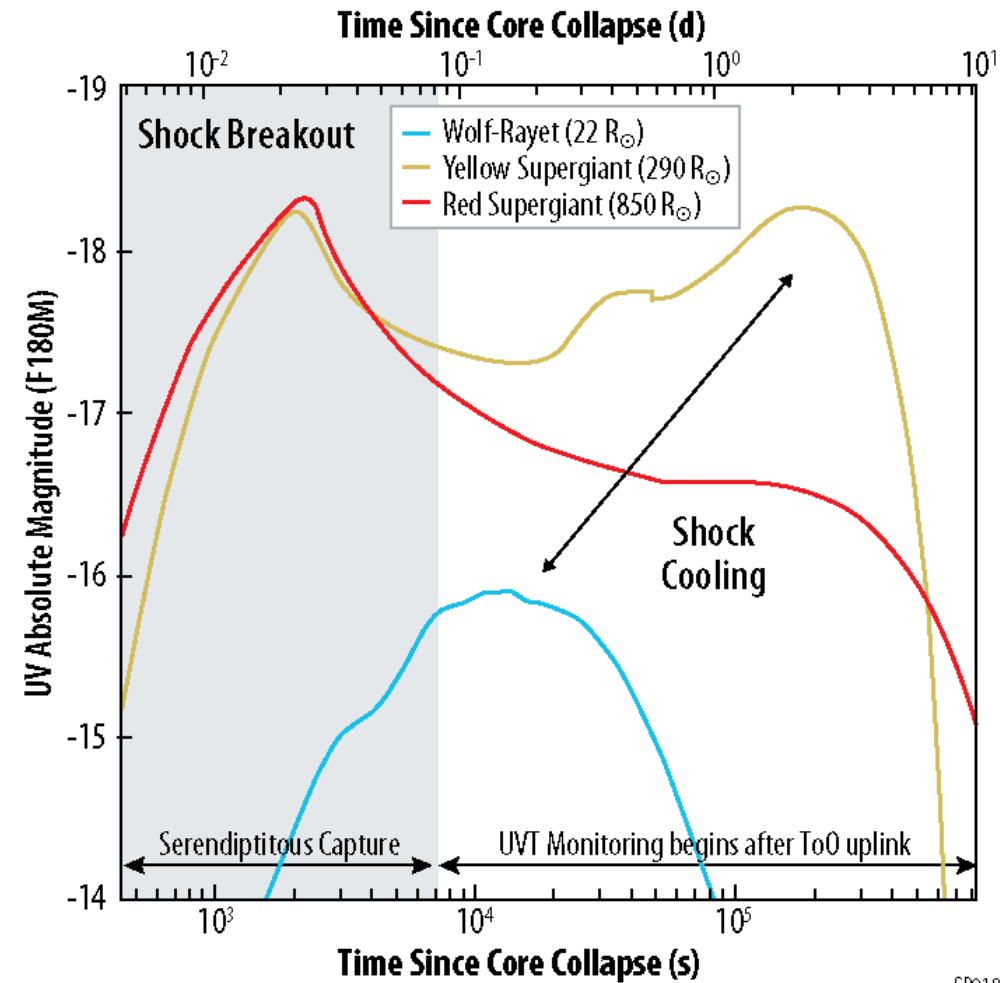
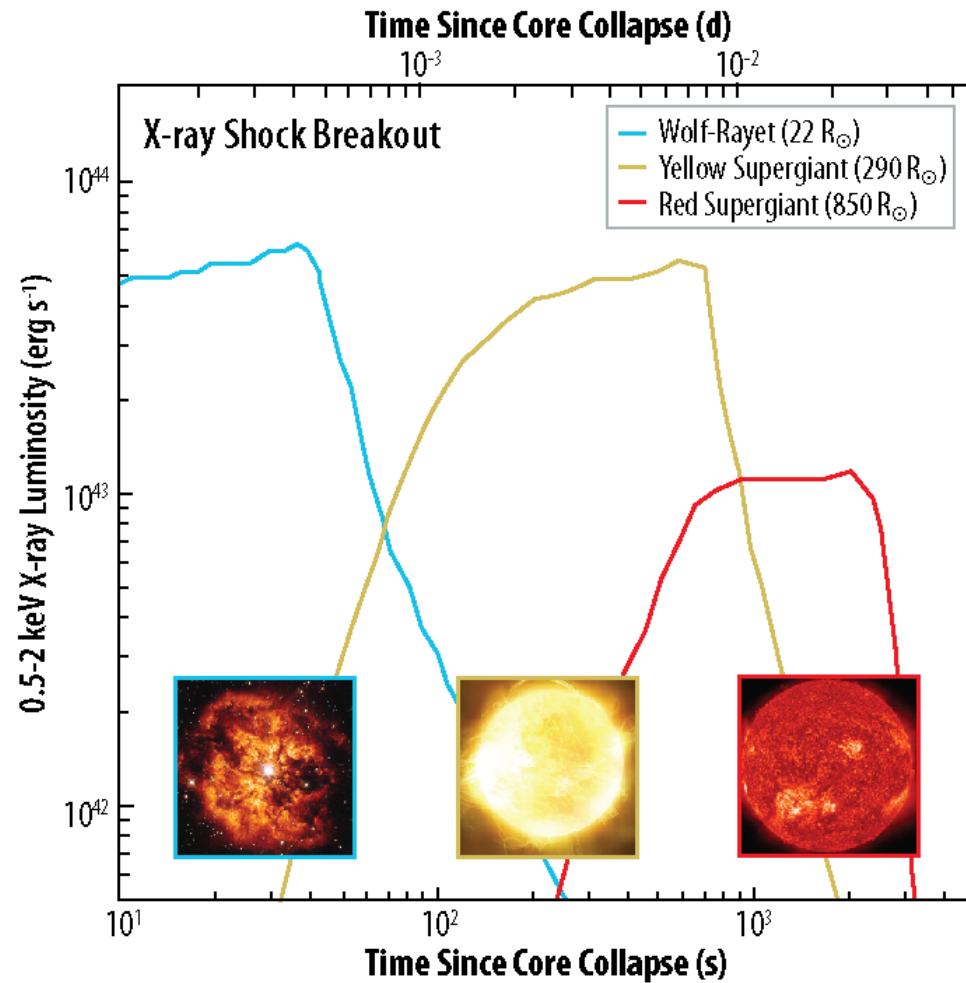

SR018

# Study of High-z Galaxy Clusters

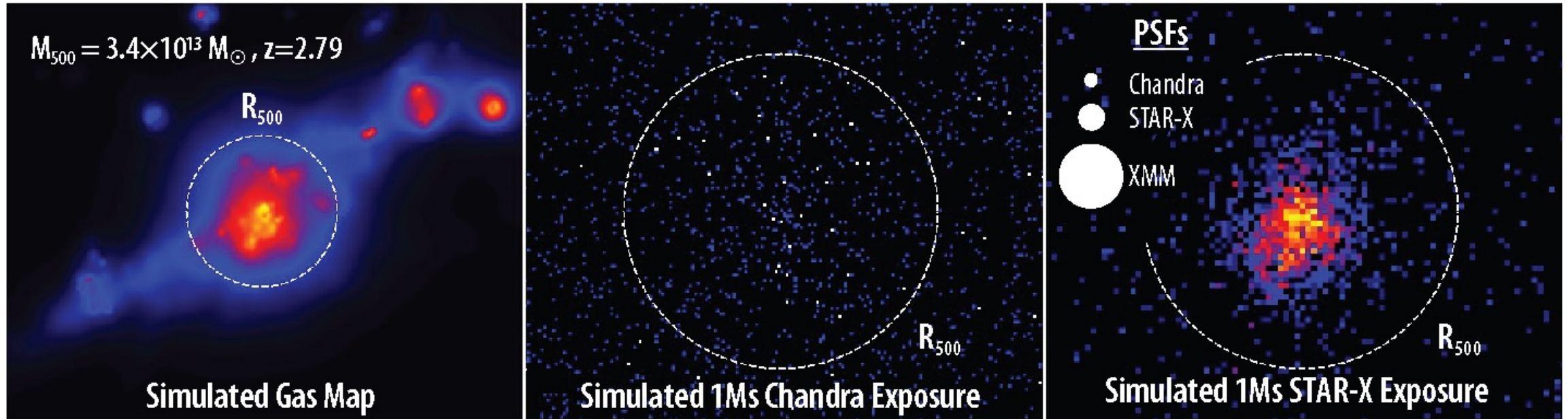

SR026

# Why STAR-X and Why Now?

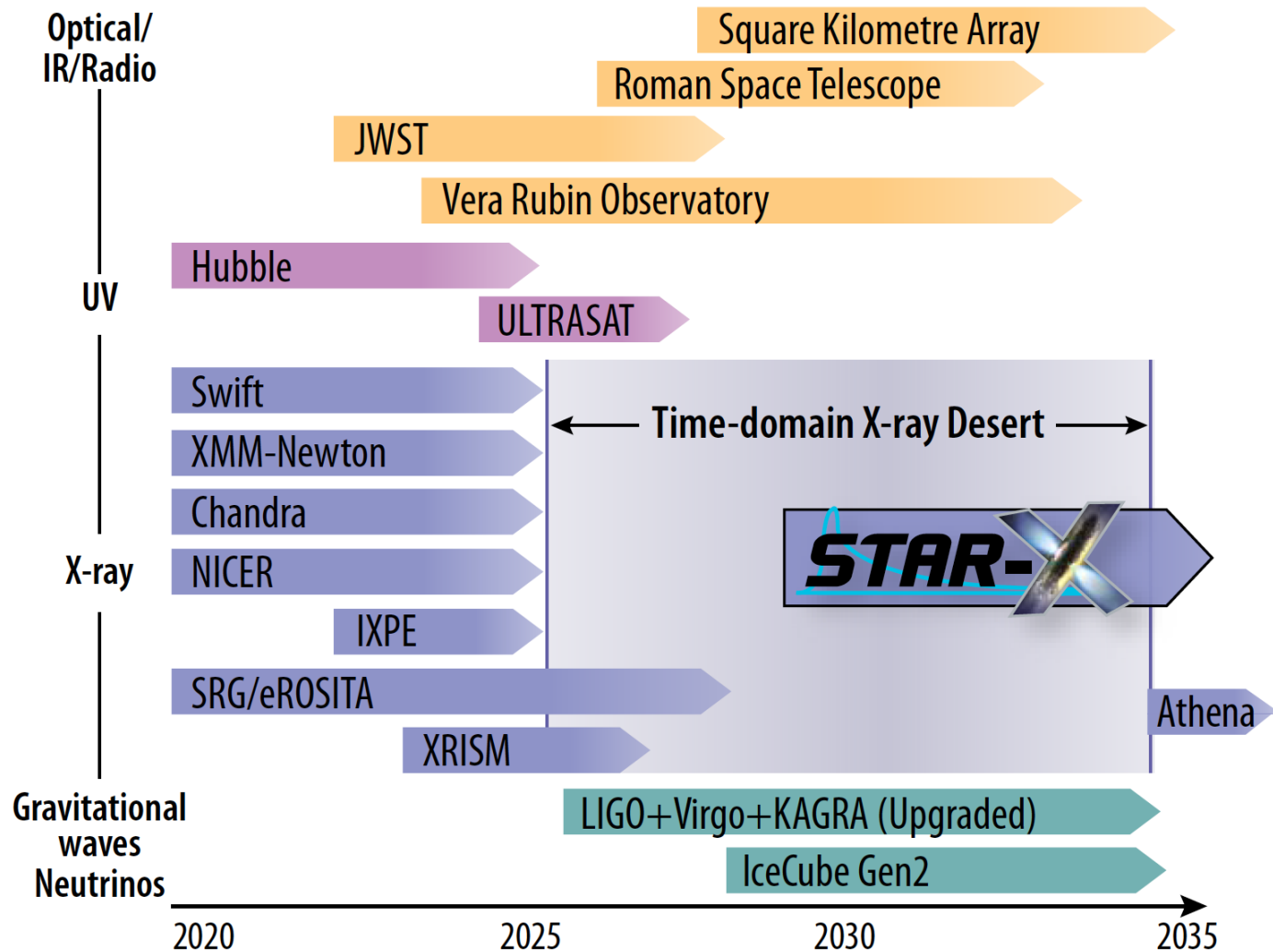

STAR-X fills the gap in X-ray and UV time-domain coverage in the late 2020s, providing simultaneous X-ray and UV observations that complement optical, infrared, and gravitational wave facilities.

# Summary

- STAR-X represents a revolutionary jump in capability.
- STAR-X does great and timely science on its own.
- STAR-X complements and enhances other great observatories such as JWST, Rubin LSST, Roman WFIRST, SKA, and Athena.
- STAR-X is a timely response to Astro2020's recommendation for "a space-based, sustaining time-domain and multi-messenger program."