

Food safety of space grown crops.

NASA Crop Food Safety Workshop
September 29, 2022

M.E. Hummerick

AMENTUM-LASSO, Kennedy Space Center, FL 32899 USA

Outline

- Introduction, review of microbiological standards
- Microbiology of ISS grown crops: Veggie and APH
- Microbiology of EDEN ISS grown crops and greenhouse environment.
- Summary
- Conclusion

NASA Microbial Standards

ISS non-thermostabilized food requirements.

Factor	Limits
APC	2E+04 CFU/g for any single sample (two samples from a lot exceed 1E+04 CFU/g)
Enterobacteriaceae	100 CFU/g for any single sample (two samples from a lot exceed 10 CFU/g)
Salmonella	0 CFU/g for any single sample
Yeasts and molds	1E+03 CFU/g for any single sample (any two samples from a lot exceed 100 CFU/g or if any two samples from a lot exceed 10 CFU/g <i>Aspergillus flavus</i>)

ISS potable water requirements.

Microorganism	Limit
Bacteria (APC)	50 CFU/mL
Coliform	Non-detectable

FDA Food Safety Modernization act

STANDARDS FOR PRODUCE SAFETY Coverage and Exemptions/Exclusions for 21 PART 112

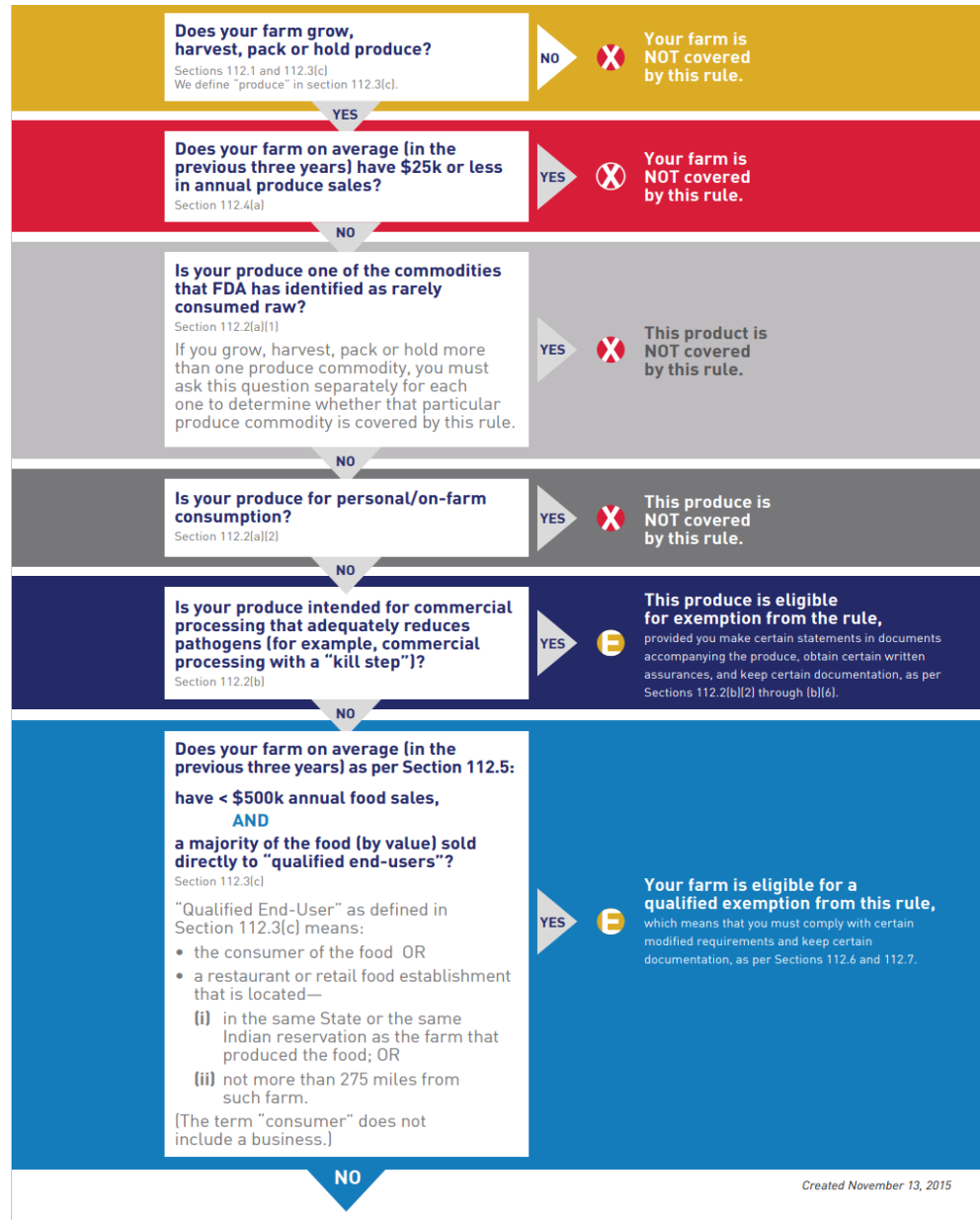

Created November 13, 2015

The final rule establishes two sets of criteria for microbial water based on the presence of generic *E. coli*, which can indicate the presence of fecal contamination.

- Agricultural water can be a source of contamination of produce.
- Public Drinking Water Systems (domestically regulated by the EPA) have the lowest relative likelihood of contamination due to existing standards and routine analytical testing.
- Commodity type (growth characteristics, e.g., near to ground) and surface properties (e.g., porosity) affect the probability and degree of contamination.
- Microbial quality of source waters, method of application, and timing of application are key determinants in assessing relative likelihood of contamination attributable to agricultural water use practices.

Microbiological sampling and analysis methods

- Total Culturable Microorganisms
 - Aerobic Plate Counts (APC)/Bacteria
 - Total Yeast and Mold Count
- Specific pathogens
 - Generic *E. coli/Coliforms* (Petriefilm)
 - *Salmonella* sp. (enrichment/selective media)
 - *Staphylococcus aureus* (Petriefilm)
 - *Aspergillus flavus* (selective media)
- Isolate identification
 - Biolog MicroID system
 - MicroSeq fungal and bacteria identification
- Community sequencing
 - MiSeq Gene sequencing (16S for bacteria, ITS for fungi). Important for definition of non-culturable microbial community.

Veggie grown crops

- To date we have grown seven different leafy green crops: All consumed by the crew.
 - Lettuce, Outredgeous (First crop 2014)
 - Chinese cabbage
 - Mizuna mustard
 - Lettuce, Waldmann's green
 - Lettuce, Dragoon
 - Amara mustard
 - Pak Choi
 - Red Russian Kale
 - Wasabi Mustard

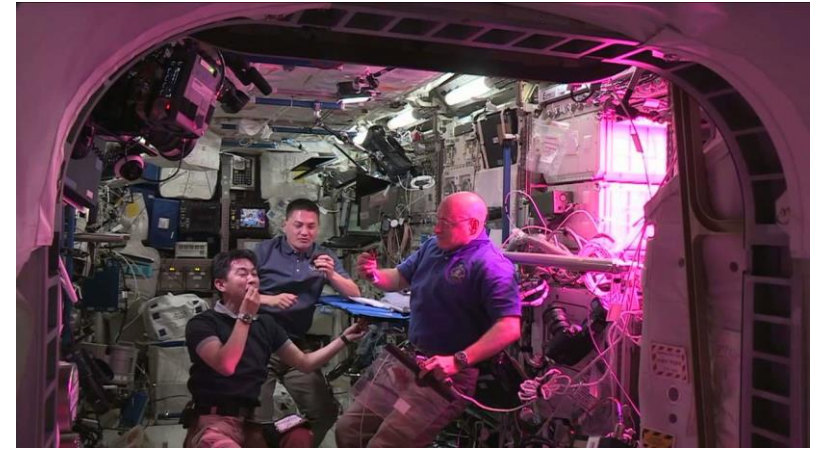

Astronauts Kelly, Lindgren and Yui. VEG 01
Photo credit NASA



Astronaut Scott Tingle tending to mixed crop in VEG 03 E and F.
Photo credit NASA

VEG 01-03 Outredgeous lettuce

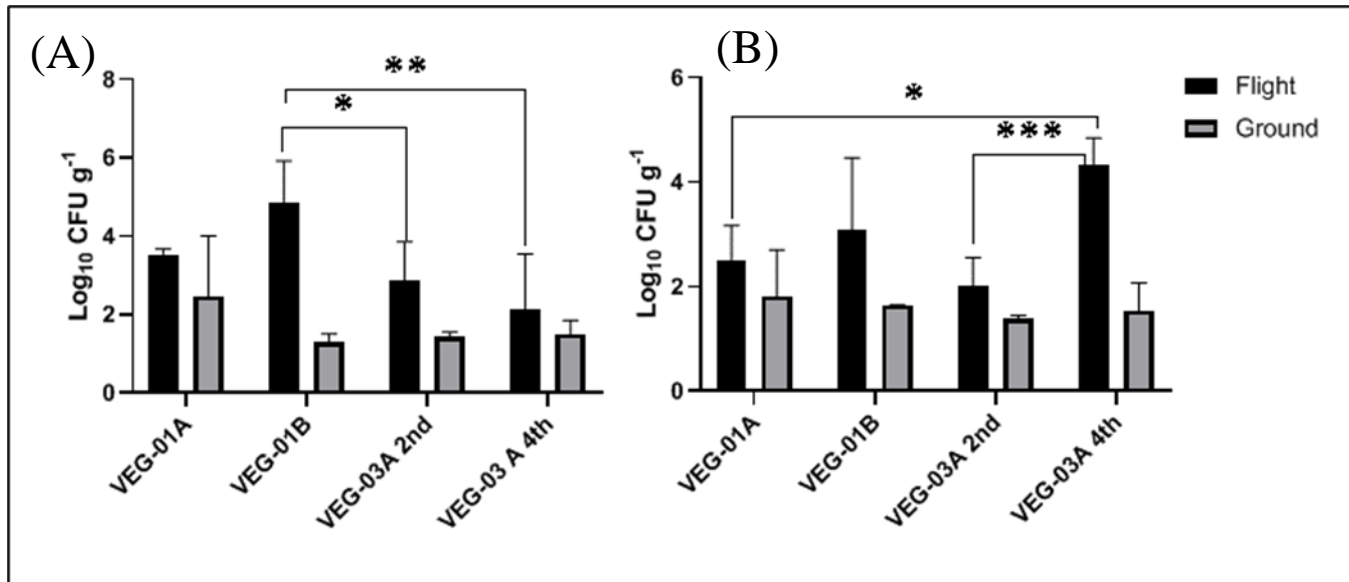

- Frozen samples returned from three Veggie tech demos in 2014, 2015 and 2016.
- Results indicate ground controls have significantly lower counts than flight.
- **Screening for select human pathogens yielded negative results.**
- This was confirmed by whole community sequencing.

Figure 1. Mean bacterial (A) and fungal (B) counts on Outredgeous leaves from three Veggie experiments. Bacterial counts are CFU on TSA per gram of frozen tissue and fungal counts are CFU from IMA plates.

Khodadad CLM, Hummerick ME, Spencer LE, Dixit AR, Richards JT, Romeyn MW, Smith TM, Wheeler RM and Massa GD (2020) Microbiological and Nutritional Analysis of Lettuce Crops Grown on the International Space Station. *Front. Plant Sci.* 11:199. doi: 10.3389/fpls.2020.00199

VEG 01-03 Outredgeous lettuce Community sequencing

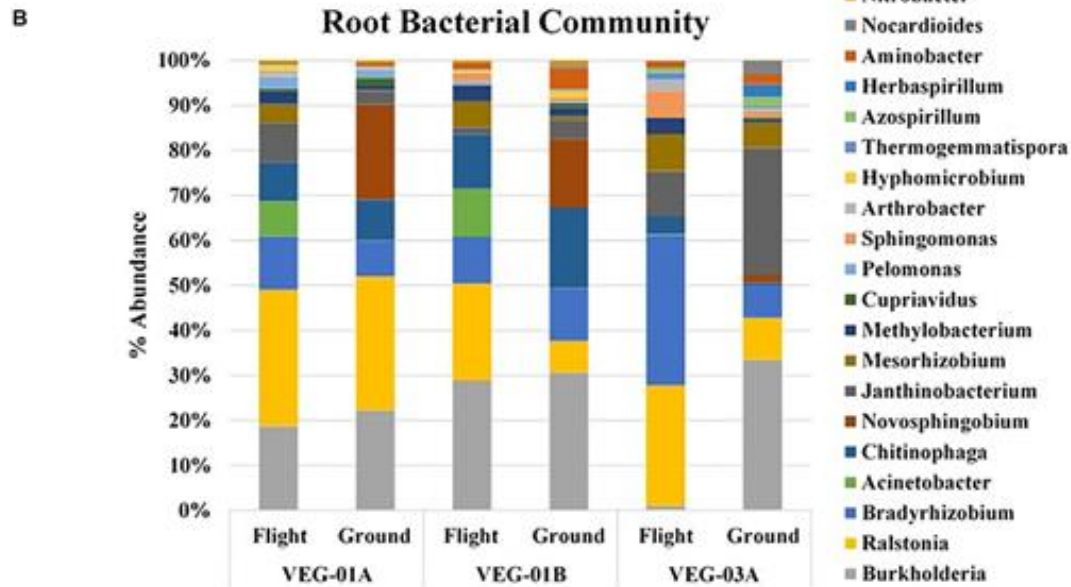
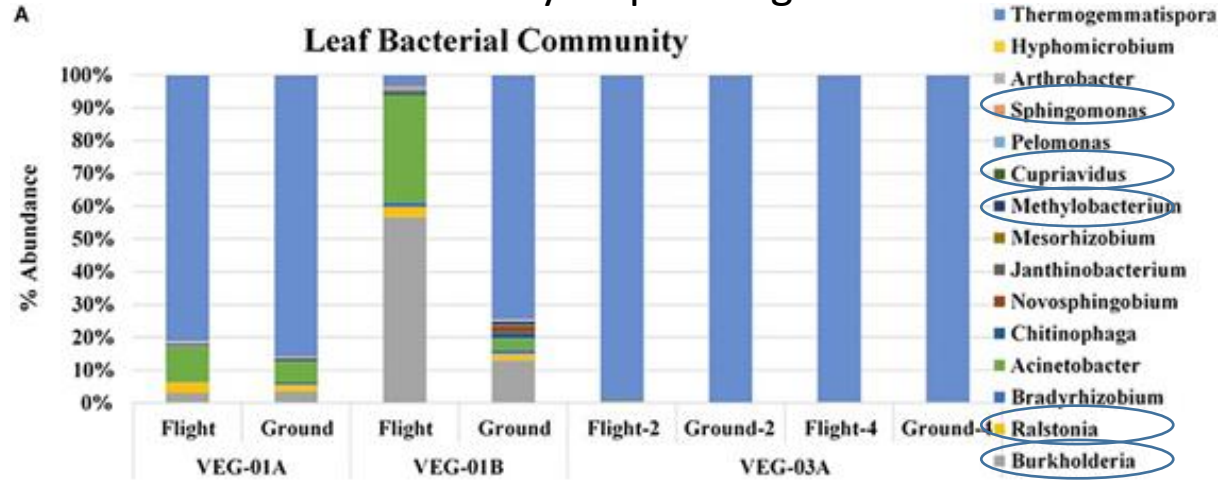

- Many of the cultured isolates were also identified in sequencing.
- Bacteria commonly cultured from ISS water were present on the leaves and roots of the lettuce in both assays.
- Many isolates are plant associated microbes, some beneficial.
- Some human associated bacteria are present such as Staphylococcus.

Cultured isolates

	VEG 01 A Leaf		VEG 01 B Leaf		Veg 03A Leaf	
	Flight	Ground	Flight	Ground	Flight	Ground
Acinetobacter	+	-	+	-	-	-
Arthrobacter	+	-	-	-	-	-
Bacillus	-	-	-	-	-	+
Burkholderia	+	+	-	-	-	+
Curtobacterium	+	-	+	-	-	-
Macroccoccus	-	-	-	-	-	+
Methylobacterium	-	-	-	-	+	+
Microbacterium	-	-	-	-	+	-
Micrococcus	-	-	-	-	+	+
Paenibacillus	-	-	-	-	+	-
Pantoea	-	-	+	-	-	-
Ralstonia	+	-	-	-	-	-
Sphingomonas	+	-	-	-	+	-
Staphylococcus	-	-	-	-	+	+

Khodadad CLM, Hummerick ME, Spencer LE, Dixit AR, Richards JT, Romeyn MW, Smith TM, Wheeler RM and Massa GD (2020) Microbiological and Nutritional Analysis of Lettuce Crops Grown on the International Space Station. *Front. Plant Sci.* 11:199. doi: 10.3389/fpls.2020.00199

VEG-03 DEF mixed crop

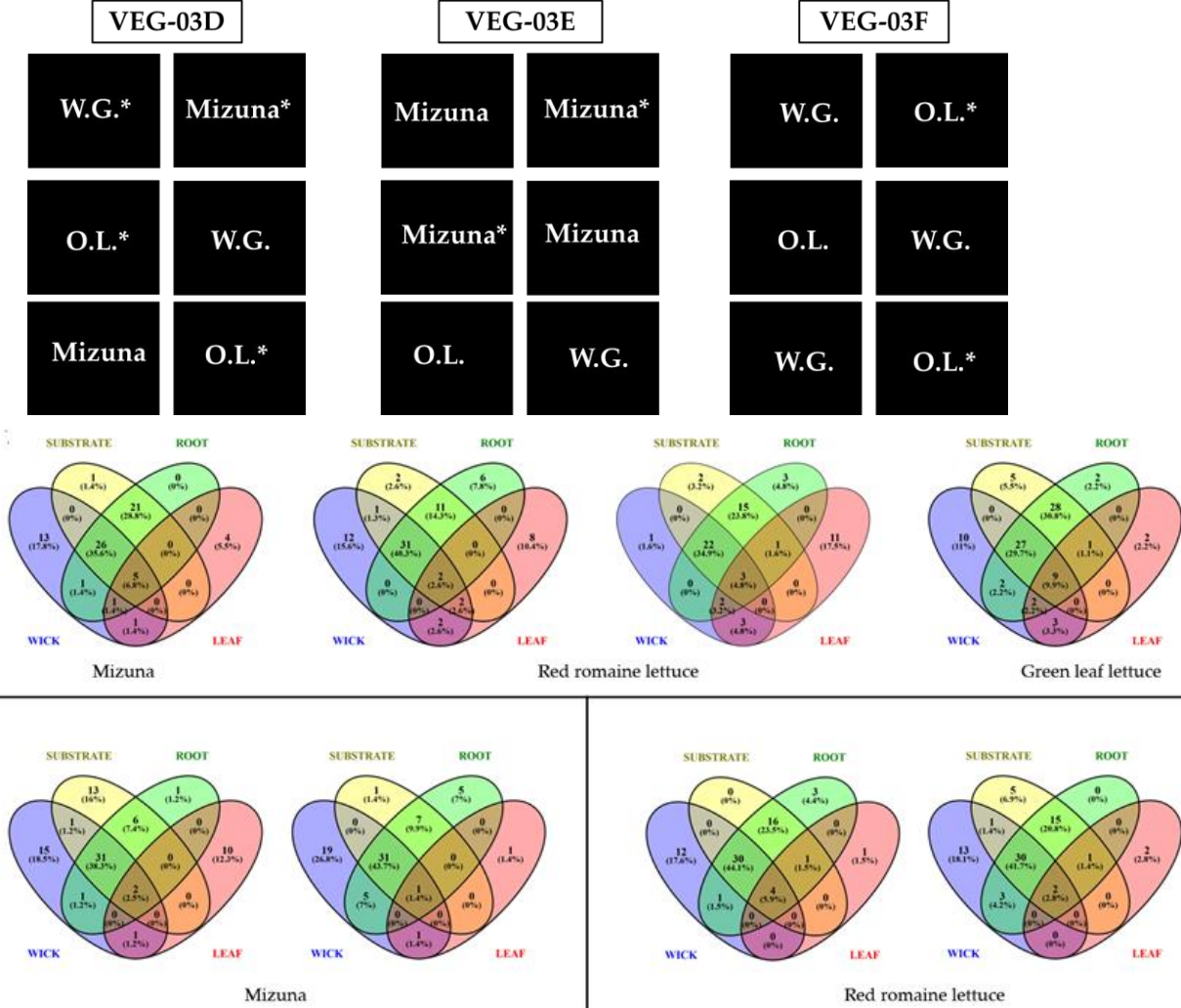

- Bacteria (APC) on leaves from Veg-03D, E, and F harvests were in the range of 4.3×10^2 (red romaine) to 3.5×10^7 (Waldman's green) CFU/g.
- Yeast and mold counts ranged from 2.4×10^4 CFU/g on Mizuna to 9.8×10^9 CFU/g on Waldmans green
- Fungal counts were higher on the second harvest leaves from all three plant types grown in VEG-03D.
- A fan anomaly during VEG-03D may have contributed to this trend, which was not found in VEG-03E and F.
- **All screening tests were negative for potential food borne pathogens, E. coli, S. aureus and Salmonella**
- This was confirmed with Next-Gen sequencing.
- Venn diagrams of the species identified in sequencing illustrate shared bacterial genera between VEG pillow root, wick and substrate but few with the edible plant leaves.

Hummerick, M.E.;Khodadad, C.L.M.; Dixit, A.R.;Spencer, L.E.; Maldonado-Vasquez,G.J.; Gooden, J.L.; Sporn, C.J.; Fischer,J.A.; Dufour, N.;Wheeler, R.M.; et al. Spatial Characterization of Microbial Communities on Multi-Species Leafy Greens Grown Simultaneously in the Vegetable Production Systems on the International Space Station. Life **2021**, 11, 1060. <https://doi.org/10.3390/life11101060>

VEG-01C, Zinnia-lessons learned.

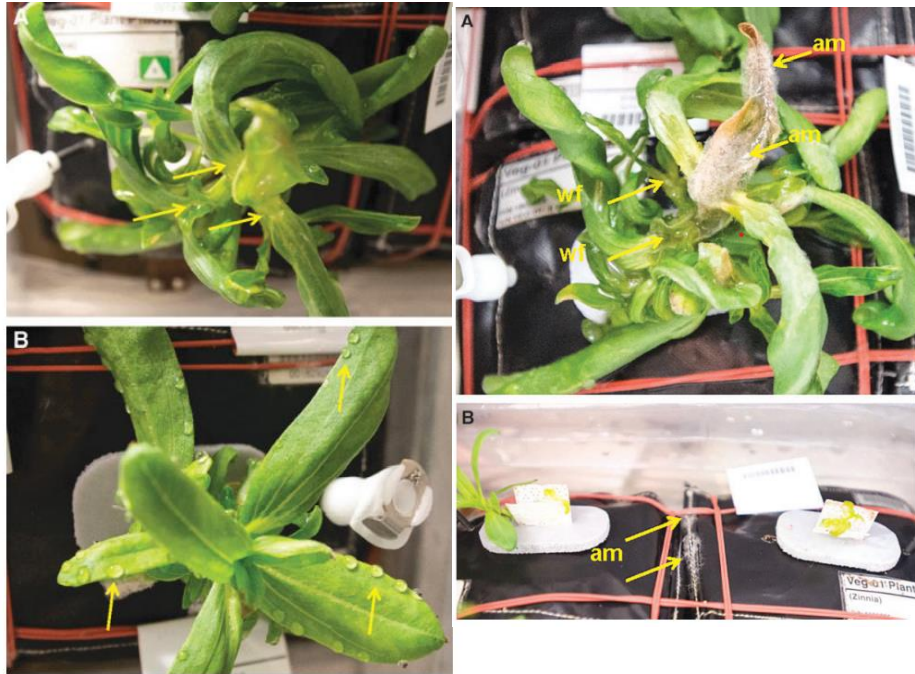

FIG. 2. *Zinnia hybrida* plants grown on the ISS during the VEG-01C experiment; images collected on 15-Dec-2015 (29 days after initiation). Developing plants exhibited significant amounts of stunting, epinasty, and chlorotic leaves prior to the observation of aerial mycelium. (A) Water films on leaf, stem, and internodal tissues (arrows) predated aerial mycelium by ~1 week (image courtesy of NASA; iss046e001341). (B) Guttation fluid (arrows) was observed on leaf margins at the same time that water-soaked tissues were present (image courtesy of NASA; iss046e001342). Figures 2A and 2B are approximately 10 cm (high) by 10 cm (wide).

Schuerger, A. C., Amaradasa, B. S., Dufault, N. S., Hummerick, M. E., Richards, J. T., Khodadad, C. L., Smith, T. S. and Massa, G. D. *Fusarium oxysporum* as an Opportunistic Fungal Pathogen on *Zinnia hybrida* Plants Grown on board the International Space Station. 2021. *Astrobiology*, Volume 21, Number 9 DOI: 10.1089/ast.2020.2399

- Operations to remove visible mold growth were developed.
- Cleaning and debris operations were effective in minimizing subsequent fungal growth.
- Environmental conditions for optimal plant growth are critical for plant health and food safety.



Veg Hazard Analysis Critical Control Points (HACCP) Plan

Process Step/Control Point	Food Safety hazard	Methods to reduce hazard	CCP
Ground processing-pillows	Introduction of microbes via handling and materials.	Sterilize components, aseptic technique used while assembling	1
Ground Processing-Seed	Introduction of microbes via handling and indigenous microbes present on seeds	Disinfection. Certification of pathogen free seed. Use of sanitary handling practices	2
Packing	no		
Transport	no		
Integrate with Veggie hardware	Introduction of microbes via handling.	Use of sanitary handling.	3
Watering	Introduction of microbes via water supply or unsanitary handling	Water is potable quality and treated with biocide.	4
Grow	Potential contamination from air and human presence, increase in indigenous flora due to availability of nutrients.	Use of sanitary handling. Minimize handling of plants before harvest.	5
Harvest	Introduction of microbes due to harvest procedures/human handling.	Sanitized instruments should be used and gloves worn.	6
Post-harvest	Microbial presence established during plant growth and introduction via handling.	Crops should be sanitized (1% Prosan wipes) before consumption following procedures. Veggie facility should be thoroughly sanitized.	7

PH04-Espanola Chilis in Advanced Plant Habitat.



NASA astronaut and Expedition 66 flight engineer Megan McArthur is seen with a taco made using fajita beef, rehydrated tomatoes and artichokes, and chile peppers. The chile peppers were grown as part of the Plant Habitat-04 investigation aboard the International Space Station.

Credits: NASA



- Bacterial and fungal counts in EDU tests and fruit returned from flight ranged from < detection limit to 112 CFU/ g
- Used ProSan wipes to sanitize fruit.
- Seed sanitization was critical due to rapidly growing fungus on unsanitized seeds.
- Chlorine gas sanitization was effective in eliminating the fungus on seeds.

EDEN ISS



- EDEN ISS Greenhouse: A confined test facility at the Neumayer III station in Antarctica for testing methods for space crop production.
- A unique opportunity to evaluate the microbiology of plants grown in an ecologically isolated environment.
- Plants are cultivated in an aeroponic system in a potentially low microbial diversity environment.
- Like a space craft, microbes are introduced by the crew, water, air and other environmental factors.

Microbial samples

- Edible plant parts: Outredgeous lettuce (25), Waldmans green lettuce (15), Mizuna mustard (15), Amara mustard (5), Toscano Kale (5), Basil Dolly (5), Chives (3), Oregano, (3), Parsley Laura (10), Peppers: Chimayo (4), Espanola (4), Mimi Red (4), Red Skin (4), Joy Red tomato (5), Red Robin tomato (10), Radish leaves (5) and Radish (5).
- Environmental samples: Surface swabs and nutrient solution. Weekly for 10 weeks then monthly through 11th month.
- Root samples of the plants.



Rack	L1		L2		L3		L4		Level
	L	R	L	R	L	R	L	R	
4	Tomato – Red Robin 4P, 4M	Tomato – Red Robin 4P, 4M	Tomato – PAT orange 4P, 4M	Tomato – PAT orange 4P, 4M	Rosie 6P, 2M	Parsley - Laura 20P, 4M	Kale - Toscano 12P, 4M	Lettuce - Waldmann's Green 6P, 2M	4
			Tomato – PAT orange 4P, 4M	Tomato – PAT orange 4P, 4M	Mizuna 12P, 4M	Rucola 36P, 4M	Lettuce - Othilie 12P, 4M	Nursery	3
2	Cauliflower – Hybrid Baby 5P, 4M	Broccoli – both varieties 5P, 4M	Tomato – Joy Red 4P, 4M	Tomato – Joy Red 4P, 4M	Swiss Chard – Bright lights 12P, 4M	Frizzy Lizzy 20P, 4M	Basil - Dolly 20P, 4M	Basil - Dolly 20P, 4M	2
					Radish – Raxe 36P, 4M	Mint 12P, 4M	Lettuce - Outredgeous 6P, 2M	Lettuce - Expertise 6P, 2M	1

Rack	R1		R2		R3		R4		Level
	R	L	R	L	R	L	R	L	
4	NASA plant cultivation system								4
			Tomato - Amoroso 2P, 4M	Tomato - Amoroso 2P, 4M	Cucumber - Picowell 2P, 6M	Cucumber - Picowell 2P, 6M	Pepper - Mimi Red 4P, 4M	Pepper - Española 2P, 4M	4
2	Kohlrabi - Korist 5P, 4M	Kohlrabi - Korist 5P, 4M					Pepper - Chimayo 2P, 4M	Pepper - Redskin 2P, 4M	2

Bacterial counts

APC

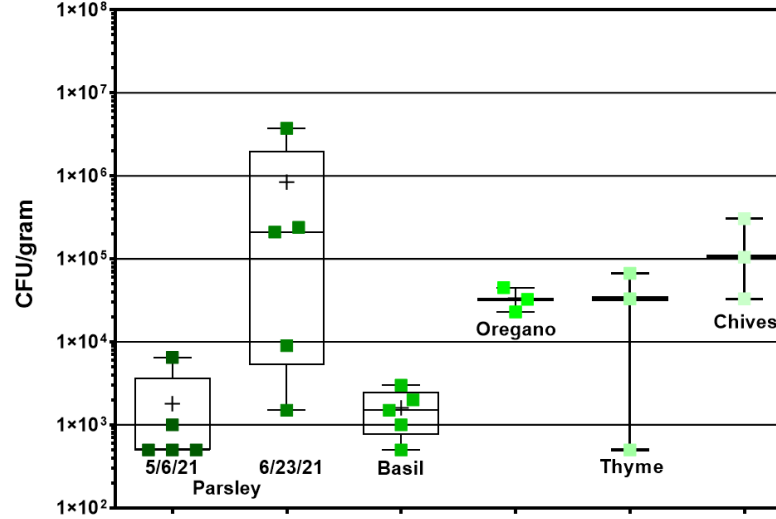
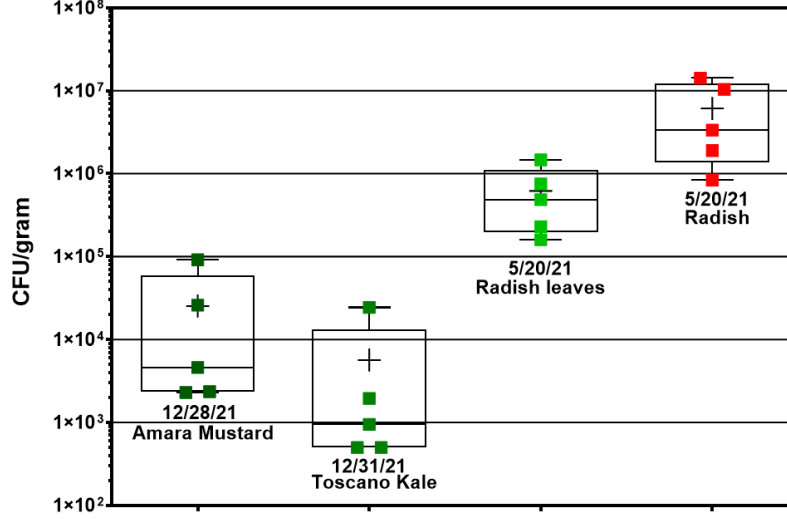
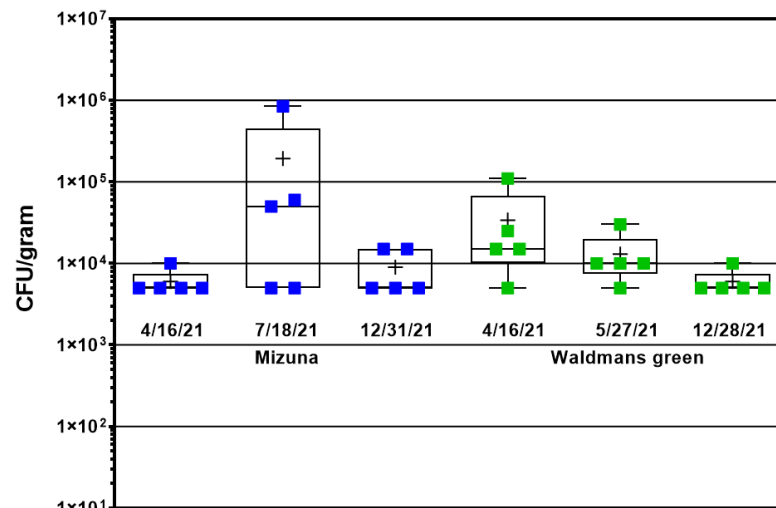
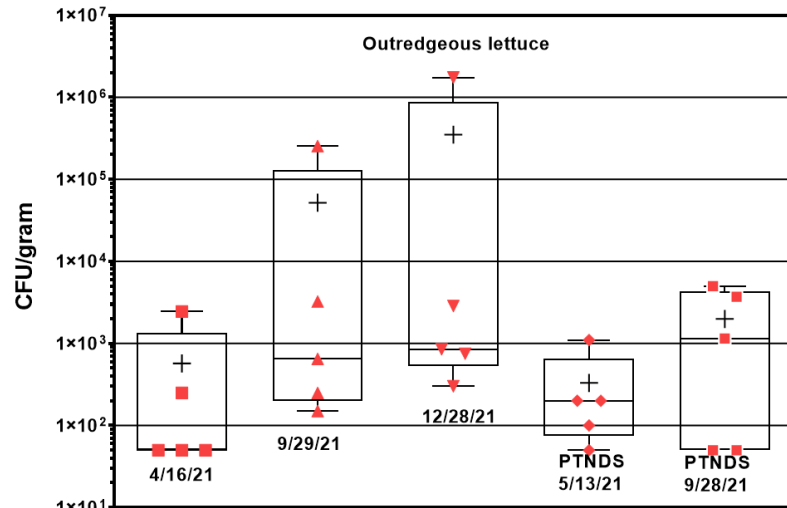

- Bacterial counts trended upward with each harvest of Outredgeous lettuce ranging from ≤ 50 CFU/g to 3.5×10^5 CFU/g.
- 3/5 samples from the July harvest and 2 from the December harvest of Mizuna were above the NASA limit ranging from below detection limit to 8.5×10^5 CFU/g.
- Waldman's green counts were below detection to 1.1×10^5 CFU/g.
- Of the five herbs sampled, Parsley was the only one with a "cut and come again" harvest with an increase in both bacterial and fungal counts after the first harvest.

Fungal counts

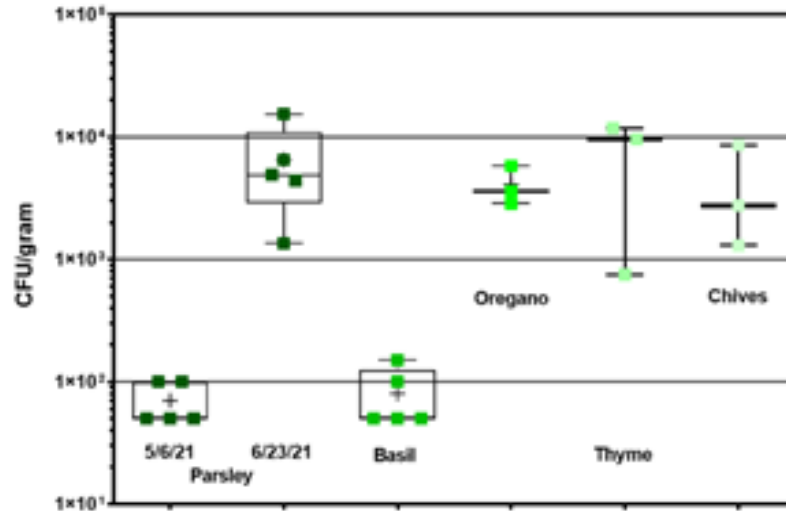
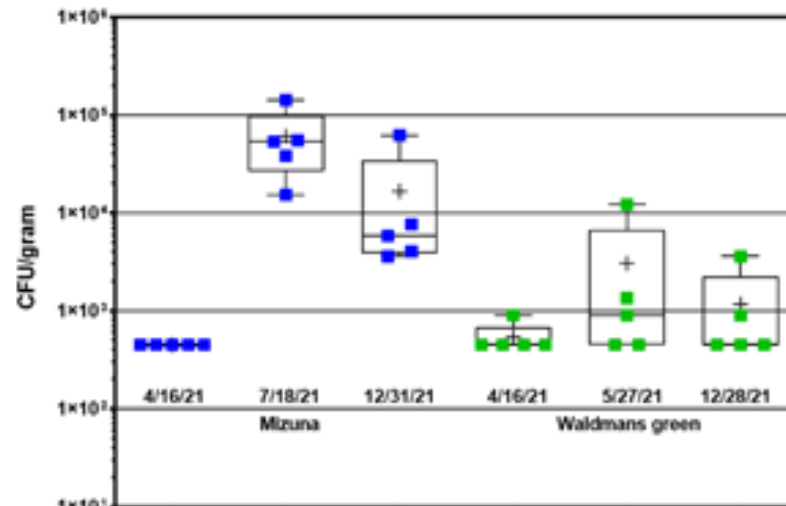
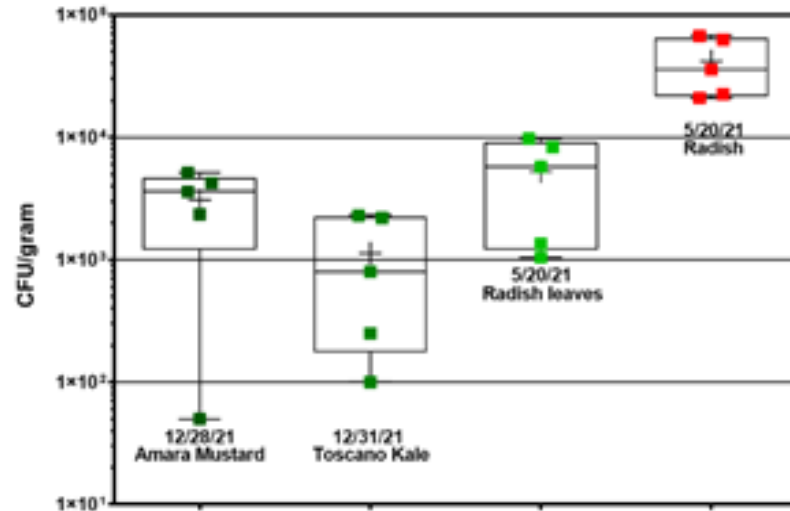
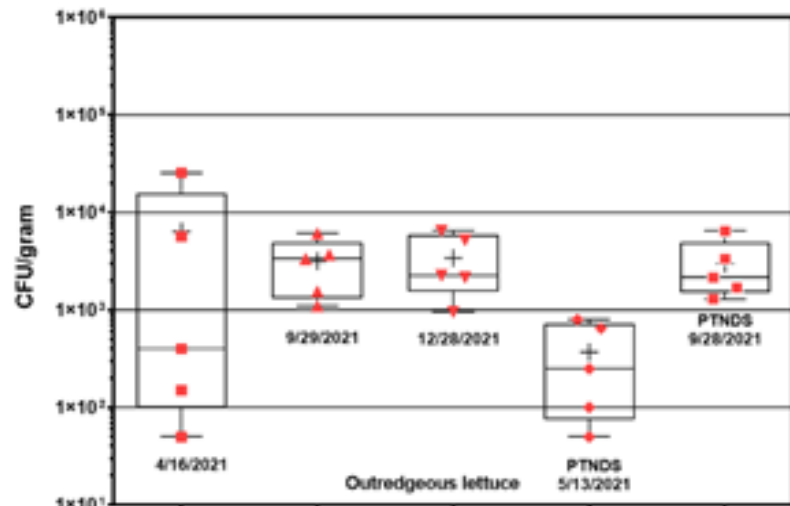

- A similar trend in increased fungal counts was seen with the consecutive harvests of Outredgeous lettuce, Mizuna and Waldmans green.
- The NASA standard for yeast and mold on non-thermostabilized food is 1×10^3 CFU/g. Several of the leafy greens and herbs exceeded this standard.

Tomato/pepper

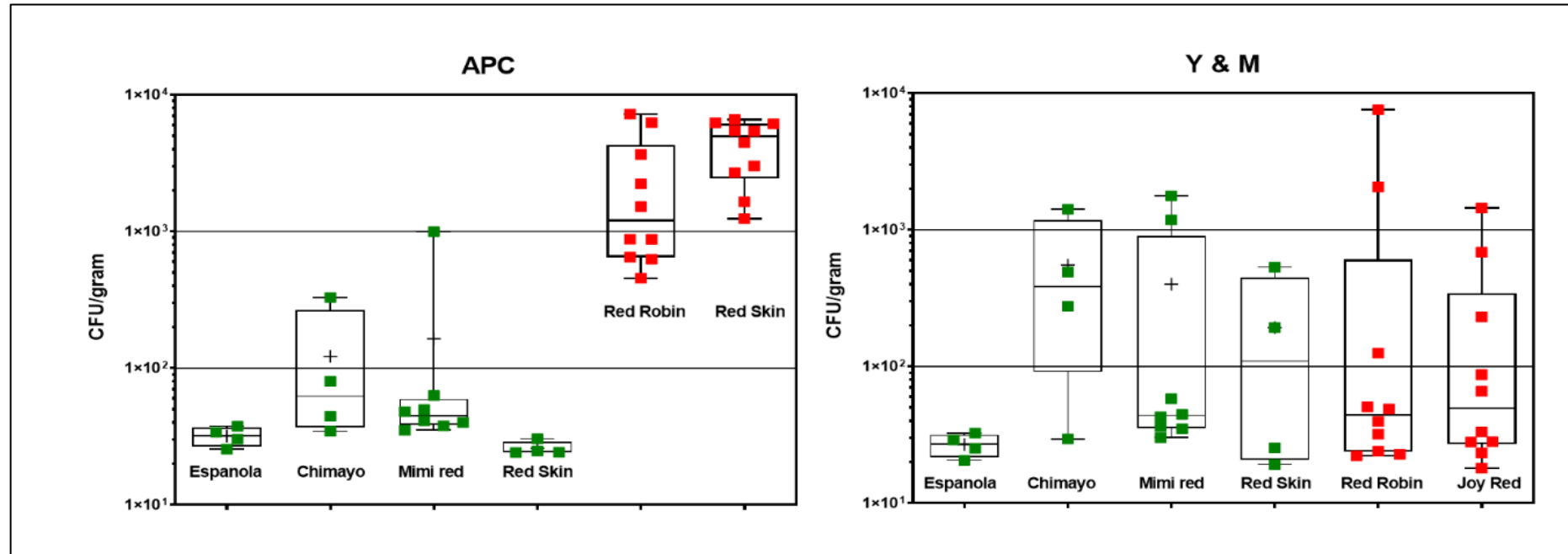

- The four varieties of peppers had low microbial counts overall.
- The bacterial counts were all below 1,000 CFU/g, Espanola and red skin were below or at detection limit.
- Red Robin and Joy Red tomatoes had bacterial counts all below 10^4 CFU/g.
- Fungal counts on Espanola peppers were very low < 50 CFU/g.
- The highest fungal count on the pepper varieties was 1.7×10^3 CFU/g on the Mimi Red pepper.

Environmental Samples

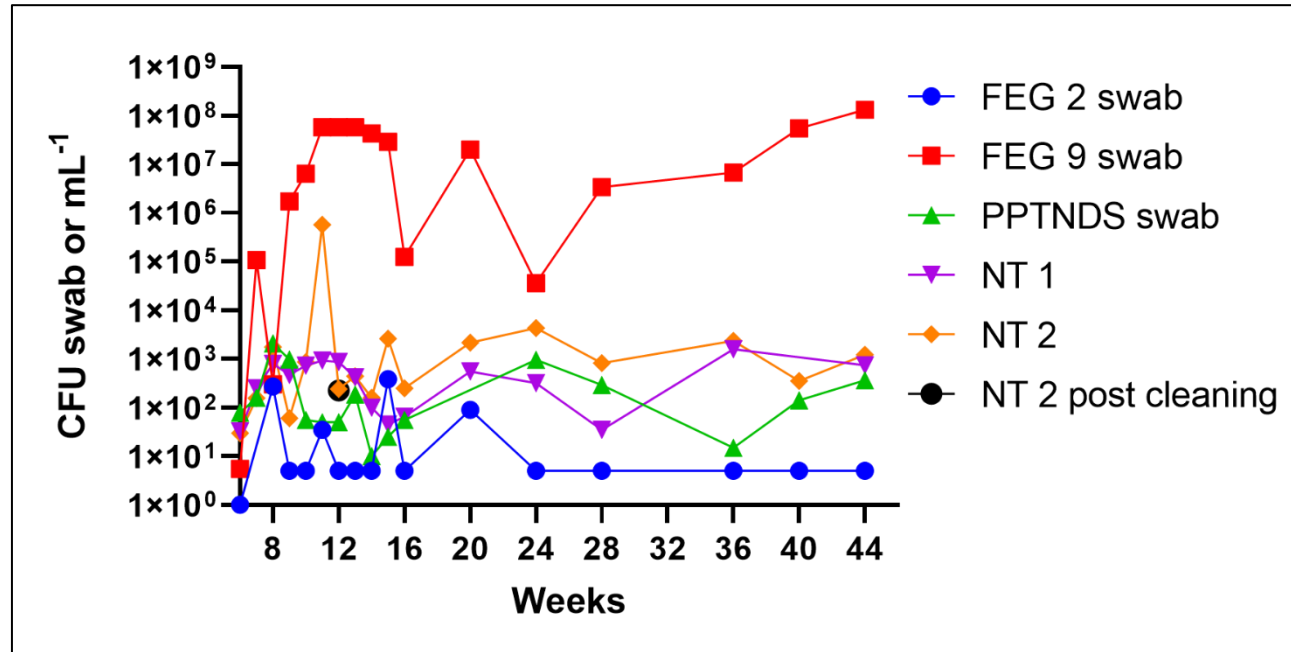

- FEG 2 (wall) was low in bacterial and fungal load, ranging from ≤ 1 CFU/25cm² to 385 CFU/25cm²
- FEG 9 (floor) had the highest bacteria load increasing over the first 10 weeks of sampling from week 6 to week 16
- The surface of the PPTNDS ranged from, detection limit to 2.1×10^3 CFU/cm².
- The nutrient tank levels fluctuated over the 11 month period. Nutrient tank 2 reached a peak of 5.7×10^5 bacteria CFU/mL at 11 weeks but the counts dramatically declined by 3 orders of magnitude after a cleaning event.
- Fungal counts over the 11 month sample period were low, most below detection limit with the exception of the floor sample.

Comparison

Crop type	Location	CFU/gram			
		APC	Yeast and Mold	E. coli	Coliform
Leafy greens	EDEN	$\leq 50-1.7 \times 10^6$	$\leq 50-1.4 \times 10^5$	Neg	Neg
Leafy greens	Veg flight	$< DL-3.5 \times 10^7$	$< DL-9.8 \times 10^9$	Neg	Neg
Leafy greens	Market*	$1 \times 10^4 - 1 \times 10^9$	$2 \times 10^4 - 1 \times 10^6$	$< DL-10^5$	$< DL-10^9$
Leafy greens	Field/hydroponic**	$4 \times 10^4 - 2 \times 10^8$	$8 \times 10^2 - 2 \times 10^6$	$< DL-10^2$	$< DL-10^7$
Peppers	EDEN	$< DL-1.0 \times 10^3$	$< DL-1.8 \times 10^3$	Neg	Neg
Peppers	APH	$< DL-1.1 \times 10^2$	$< DL-1.2 \times 10^2$	Neg	Neg
Peppers	Market	$6.6 \times 10^2 - 1 \times 10^6$	$36-1.4 \times 10^3$	Neg	Neg
Tomato	EDEN	$4.6 \times 10^2 - 7.2 \times 10^3$	$< DL-7.6 \times 10^3$	Neg	Neg
Tomato	Market	$< DL-8.7 \times 10^4$	-	Neg	Neg
Microgreens	Chamber	$8.5 \times 10^6 - 1.5 \times 10^9$	$1.9 \times 10^3 - 3.4 \times 10^5$	Neg	+
Microgreens	Market	$3.7 \times 10^7 - 4.1 \times 10^8$	$8.8 \times 10^2 - 5.1 \times 10^3$	Neg	+

*Market values are from literature as well as our lab analysis of produce from local markets. **Literature values.

Conclusions

- The number of bacteria and fungi on growth chamber and ISS-grown produce are no higher than market produce from field settings.
- Our analysis indicates that high bacterial counts on produce are not necessarily a risk, however these data may indicate trends.
- Repeat harvests may result in increased microbial counts especially fungi. Steps should be taken to minimize further microbial contamination such as increased decontamination of surfaces with sanitizing wipes and the removal of unnecessary materials
- Microbial monitoring of inputs into the plant growth systems and the plants is important and should enable detection of any trends indicating increased microbial presence.
- Defining risks and the development of standards and best practices for space-grown crops should allow routine safe consumption of these items.

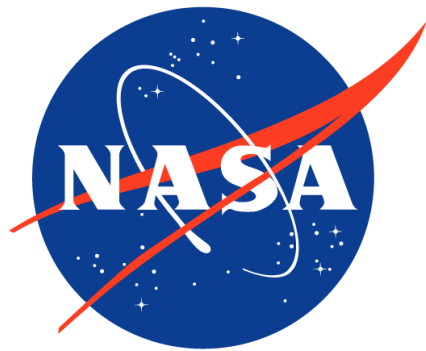

Thank you!
