



NASA's Behavioral Health and Performance Services for Long Duration Human Spaceflight Missions

Gary E Beven, MD
Chief, Space Medicine Operations Division
Chief of Aerospace Psychiatry
NASA Johnson Space Center

American Academy of Psychiatry and the Law
46th Annual Meeting



Thank You

- Dr Philip Resnik for triggering my initial passion for forensic psychiatry
- Dr Jeffrey Metzner for supporting my career in forensic psychiatry and for being a mentor in correctional psychiatry



NASA's Behavioral Health and Performance Services for Long Duration Spaceflight Missions



Goals of the presentation include:

- Understand the behavioral components of NASA's 2021 astronaut selection
- Understand the basics of space station development and long duration spaceflight history, as well as the behavioral challenges associated long duration spaceflight training and missions
- Understand how NASA and its international partners (Russia, Europe, Japan, and Canada) provide behavioral health and performance services and countermeasures to astronauts and cosmonauts during long duration spaceflight missions on the International Space Station

Johnson Space Center (JSC) Houston, Texas



Mission Control Center



“Uh, Houston, we've had a problem” – Jim Lovell, Apollo 13, April 13, 1970

“Houston, Tranquility Base here. The Eagle has landed” – Neil Armstrong, Apollo 11, July 20, 1969

Dr Jeffrey Metzner Visit to JSC

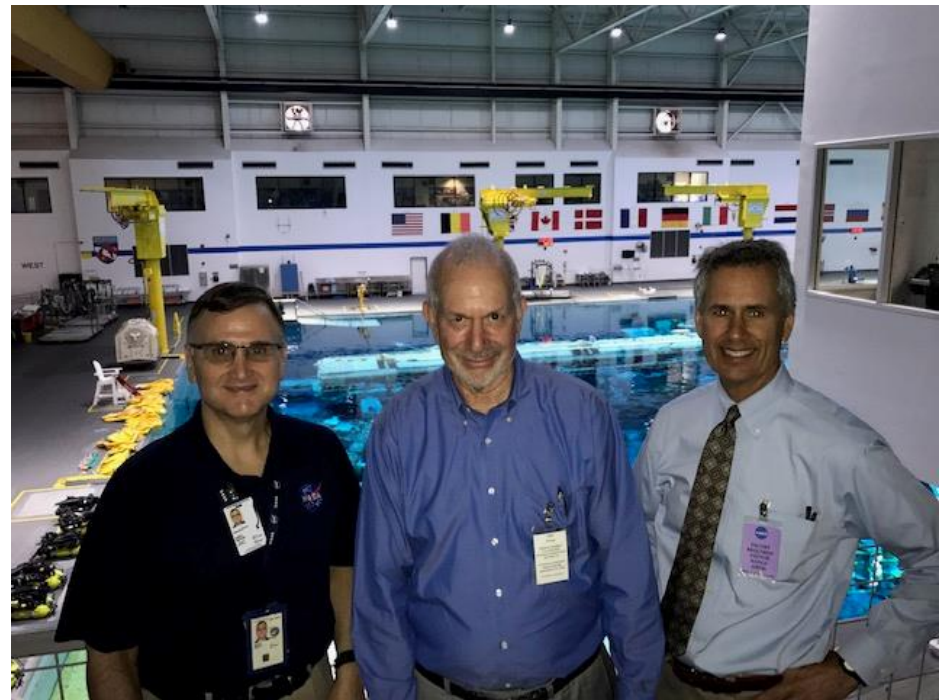

NASA Human Spaceflight Programs

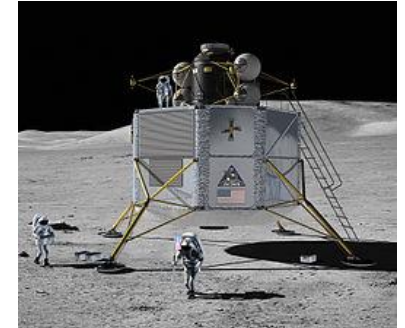
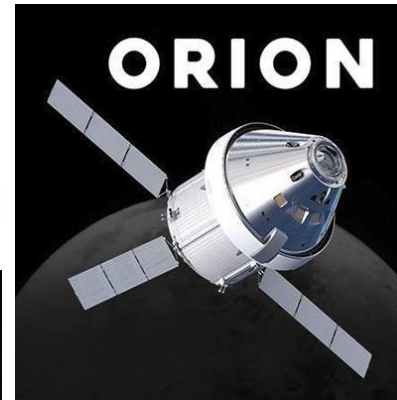

My Journey from correctional psychiatry to NASA

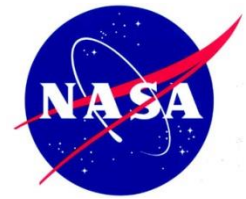

First visit to JSC during Air Force Flight Surgeon Training with Dr JD Polk - 1998



Space Medicine Operations Division Chief, JSC

"We have to work here one day...let's commit to do whatever it takes to get back here"



NASA Chief Health and Medical Officer, NASA HQ

What is aerospace psychiatry?

- **Aerospace Medicine**

- Aerospace medicine is a sub-discipline of preventive and occupational medicine that ties together physics, physiology, life support, engineering, and medicine to protect aircrew and patients in the realm of aerospace

- **Flight Surgeon**

- An operational practitioner of aerospace medicine
- Physicians who are primarily responsible for the medical evaluation, certification and treatment of military aviation personnel — e.g., pilots, naval flight officers, navigators/combat systems officers, and also astronauts

- **Space Medicine**

- Branch of aerospace medicine that deals with the physiological and psychological effects on the human body during spaceflight

- **Aerospace Psychiatry**

- Merging of the disciplines of aerospace medicine, space medicine and psychiatry
- Focus on maintaining peak mental/psychological fitness of aviators and astronauts in challenging circumstances and environments

- NASA's Mercury 7
 - Alan Shepard USN
 - Gus Grissom USAF
 - John Glenn USMC
 - Scott Carpenter USN
 - Wally Schirra USN
 - Gordon Cooper USAF
 - Deke Slayton USAF



- Requirements—experienced military test pilots; 5'11" or less in height and 180 lbs. maximum
- 500 applications
 - 110 qualified
 - 18 finalists
 - 7 selected (1.4% selection rate)



- Project Mercury astronaut candidate selection committee (1959)
 - 1 senior management engineer
 - 1 test pilot engineer
 - 2 flight surgeons
 - 2 psychologists: Allen O. Gamble (NASA HQ) and Robert Voas (US Navy)
 - 2 psychiatrists: George E. Ruff and Edwin Z. Levy (both active-duty USAF physicians)



Behavioral Components of NASA's 2021 Astronaut Selection



- 23 Astronaut Classes from 1959 to 2021
- 359 astronaut candidates selected in 63 years
- 1996 largest class: 44 (height of Space Shuttle Program era)
- Current active astronauts: 44
- Over 12,000 Applications for class of 2021
- Current NASA astronaut candidates (ASCANS): 10



2021 Astronaut Selection Schedule



0.083% selection rate (all applicants)
0.37% selection rate (qualified applicants)
2.5% selection rate (highly qualified applicants)

Note: 2021 and 2017 selection cycles with nearly identical statistics



- Selection is a critical countermeasure for mitigating risks to behavioral health and performance in space
- Considered to be our most important countermeasure targeting both individual factors and social/crew factors

Two complementary but different selection processes:

- Psychiatric qualification
 - According to current NASA medical standards
 - Diagnosis/No Diagnosis
 - Recommendation made to Aerospace Medical Board (AMB)
 - Historically a 2% disqualification rate including ISS and STS Programs
- Psychological suitability for spaceflight missions
 - Mission demands of ISS missions up to 12 months
 - Suitability for shorter duration Artemis missions
 - Based on desired behavioral competencies specific for spaceflight
 - Advisory information to Astronaut Selection Board (ASB) with a suitability rating provided



Behavioral Components of NASA's 2021 Astronaut Selection

Extensive medical/psychiatric screening for all final applicants:

- Comprehensive history and physical examination by NASA flight surgeon
- Neurologic, ENT, orthopedic, and ophthalmic exams
- Audiology assessment
- 5-day ECG monitoring
- Cardiac stress testing with VO2 max
- Echocardiogram
- Cardiac CT (calcium score)
- Carotid Doppler
- Thyroid ultrasound
- Pulmonary function tests
- Dexa scan
- CXR
- Abdominal and renal ultrasound
- GYN exam for females including mammogram and pelvic ultrasound
- Extensive lab work
- **Psychiatric/psychological examination (3.5 hours)**
- **Psychological testing (6 hours)**
- **Observed group and individual performance activities (2 days)**



Behavioral Components of NASA's 2021 Astronaut Selection



- BHP Astronaut Selection Select-In Suitability Proficiencies 2021
- Primary suitability competencies were identified and prioritized via a systematic analysis of future mission profiles, conducted in 2014 by BHP and using veteran ISS astronauts as SMEs
 - Self Regulation
 - Resilience
 - Teamwork
 - Small Group Living
 - Operational Problem Solving
 - Leadership-Followership



Behavioral Components of NASA's 2021 Astronaut Selection



- Team of external consultant psychologist and psychiatrist examiners with significant selection and assessment experience were utilized
- Valued professional attributes include
 - military service as a psychiatrist and flight surgeon or as an operational/aerospace psychologist in deployed setting
 - prior personnel selection work
 - prior astronaut selection experience
 - forensic psychiatry training and experience highly beneficial
 - Prior AAPL member NASA astronaut selection consultants:
 - Charles Scott, MD
 - James Knoll IV, MD
 - Joseph Penn, MD

Drs James Knoll and Charles Scott at the Apollo Flight Control Room during 2017 selection cycle





- Round 1 (n =120)
 - Psychological testing
 - Structured observations in Astronaut Selection Board (ASB) Phase 1 Interview
 - No suitability assessment or psychiatric diagnostic screening occurs at this stage
- Round 2 (n=30)
 - 10 applicants per week
 - Individual Exercise
 - Team Simulation Exercise
 - Team Reaction Exercise
 - Behavioral and psychiatric interviews
 - Peer ratings
 - Psychologist consultation to the astronaut selection board with a suitability rating
 - Psychiatrist opinion to Aerospace Medical Board



Behavioral Components of NASA's 2021 Astronaut Selection



- Psychological testing
 - General personality, cognitive and situational judgment tests
- Inform/direct the behavioral and psychiatric interview
 - Areas to explore in more detail
 - Relative strengths/weaknesses
 - Potential psychopathology noted
- Norms for general population, applicants, and selected astronauts
- Test battery confidential to preserve integrity of the selection process

- Psychological Testing
 - Approximately 6 hours

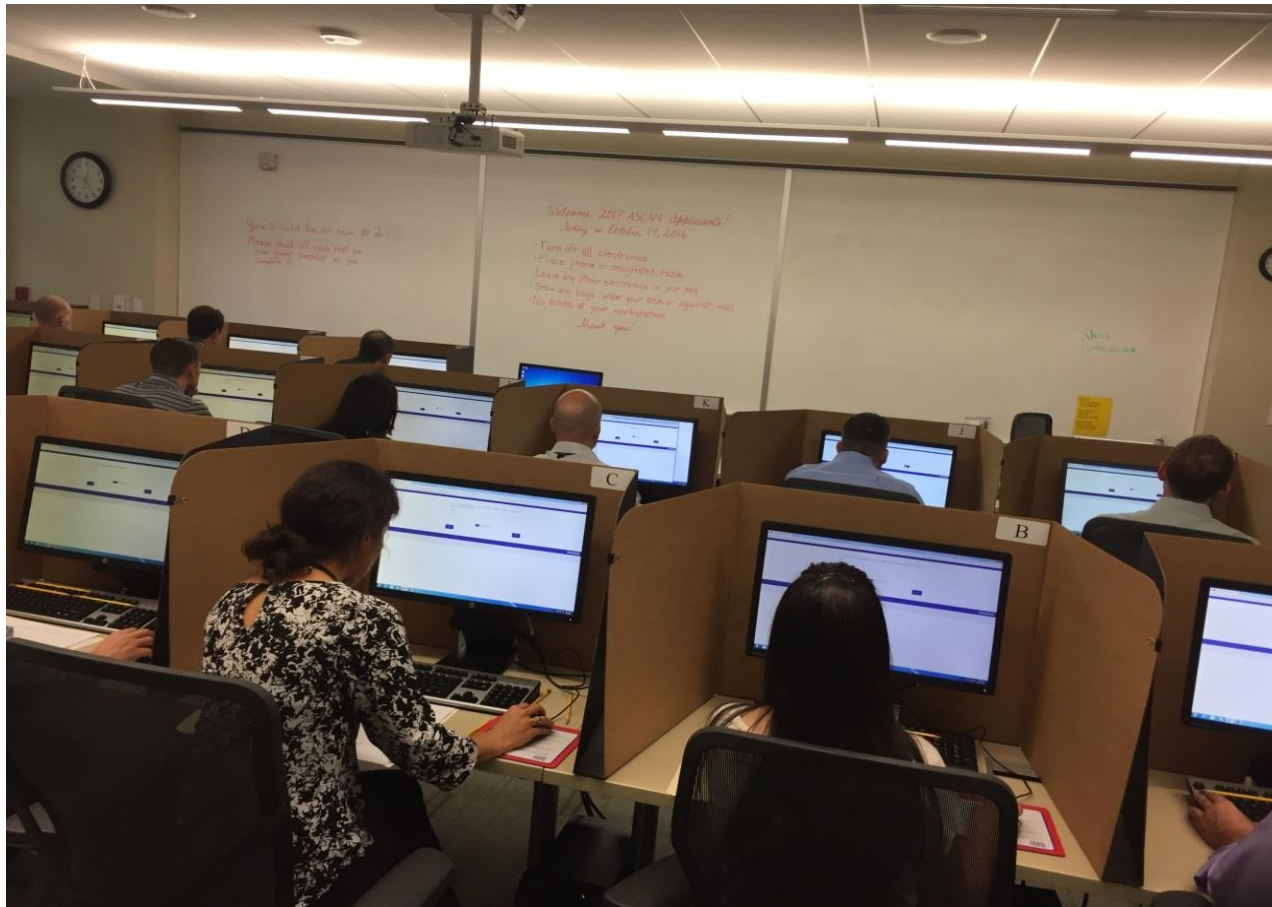

- Applicant Individual Exercise
 - Suitability competency driven
 - Individual tasks performed under time pressure
 - Observed by psychologist rater
 - Debrief with each applicant afterward



Behavioral Components of NASA's 2021 Astronaut Selection



- Applicant Team Simulation Exercise
 - Suitability competency driven
 - Team tasks with very high cognitive load
 - Observed by psychologist raters
 - Debrief with each applicant afterward



- Team Reaction Exercise
 - Suitability competency driven
 - Observed by psychologist raters
 - Debrief with each applicant afterward





Behavioral Components of NASA's 2021 Astronaut Selection



- Behavioral and psychiatric interviews:
 - 3.5 hour behavioral/psychiatric interviews
 - 2 interviewers per applicant (psychologist and psychiatrist)
 - NASA psychologist/psychiatrist floaters move from room to room—for calibration and consistency
 - Structured interview components covering spaceflight suitability competencies
 - Structured psychiatric diagnostic interview covering all major DSM 5/ ICD-11 diagnostic criteria
 - Psychologist and psychiatrist form a consensus opinion regarding applicant's suitability rating and presence of current or prior psychiatric diagnosis

2017 Astronaut Selection Applicant Case Discussions including Dr Charles Scott



Behavioral Components of NASA's 2021 Astronaut Selection

NASA Astronaut Class of 2021—"The Flies"



Behavioral Components of NASA's 2021 Astronaut Selection



NICHOLE "VAPOR" Ayers

- Colorado Springs, CO
- F-22,T-38A Pilot Instructor
- MS Applied Math, Rice
- BS Math, USAFA
- US Air Force, Major

CHRISTINA Birch

- Gilbert, Arizona
- US Track Cyclist & Prof UCR & CalTech
- PhD BioEng, MIT
- BS Math, Uni of Arizona

LUKE Delaney

- Debary, Florida
- Pilot NASA Langley
- MS AeroE, U of North FL
- BS MechE, NPGS
- Marine Corp Major, Ret

ANDRE Douglas

- Chesapeake, Virginia
- Engr John Hopkins APL
- PhD SysE, GWU
- MS Eng, Michigan/JHop
- US Coast Guard

DENIZ Burnham

- Wasilla, AK
- Drilling Ops/Energy Proj
- MS MechE, USC
- BS ChemE, UCSD
- US Navy, Lieutenant

MARCOS Berríos

- Guaynabo, Puerto Rico
- Helicopter/Test Pilot Cmdr
- PhD AeroE, Stanford
- BS MechE, MIT
- US Air Force, Major



JACK Hathaway

- South Windsor, CT
- Test Pilot/Commander
- MS Flt Dyn., Cranfield
- BS Physics, USNA
- US Navy, Commander

CHRISTOPHER Williams

- Potomac, Maryland
- Med Physicist & Prof Harvard
- Med Physics, Harvard
- PhD Physics, MIT

MOHAMMAD Al Mulla

- Dubai, UAE (MBRSC)
- Police Helicopter Pilot & Instructor
- MS Public Admin
- BS Law/Economics

NORA Al Matrooshi

- Sharjah, UAE (MBRSC)
- Piping Engr National Petroleum Construction
- BS MechE, UAE University

JESSICA Wittner

- Clovis, California
- Test Pilot/Project Officer
- MS AeroE, NPGS
- BS AeroE, Arizona
- US Navy Lieutenant Cmdr

ANIL Menon

- Minneapolis, MN
- SpaceX/NASA Flt Doc
- MD Aero/Emer, UTMB
- MS MechE, Stanford
- USAF, Lieutenant Colonel

Astronaut Classes from 2021 (#23) and 1959 (#1)



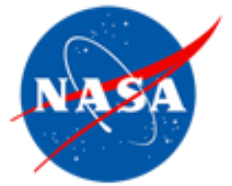

Class of 2021 Physician Astronaut



Anil Menon, MD
Former NASA and SpaceX Flight Surgeon
UTMB Aerospace Medicine Residency Graduate

Behavioral Components of NASA's Astronaut Selection



Class of 2017 Physician Astronauts



Jonny Kim, MD
Navy SEAL



Frank Rubio, MD
Army UH-60 Blackhawk Pilot

Yuri Gagarin Statue in Star City, Russia



Freedom 7 Mission

First American in Space



On May 5, 1961, Alan Shepard piloted the Freedom 7 mission

“Let’s light this candle!”



Space Stations

- No major propulsion system
- No landing system
- Other space vehicles are required for transport to and from
- **Monolithic stations** (Salyut stations, Skylab, Tiangong 1-2) constructed and launched in one piece, then joined later by a crew
- **Modular stations** (Mir, ISS, Tiangong Station, planned commercial space stations) have a core unit and additional modules with different purposes added later

History of Long Duration Spaceflight



- 51 years of space station operations (1971-2022)
- 13 Space Stations:
 - ***Salyut stations 1—7 (Russia)*** April 19, 1971—February 7, 1991; 38 Missions (**13 long duration missions**)
 - ***Skylab (US)*** May 14, 1973—July 11, 1974; 3 missions (**2 long duration missions**)
 - ***Mir (Russia)*** February 20, 1986—March 23, 2001; 39 missions (**28 long duration missions**)
 - ***International Space Station (ISS)*** November 20, 1998—present; (**68 long duration missions thus far**)
 - ***Tiangong-1*** (China) launched in 2011—deorbited 2018; one 20-day mission
 - ***Tiangong-2*** (China) launched in September 2016—deorbited 2019; one 26-day mission
 - ***Tiangong Space Station*** (China) launched April 2021

Salyut 1—the World's 1st Space Station (April 19, 1971)

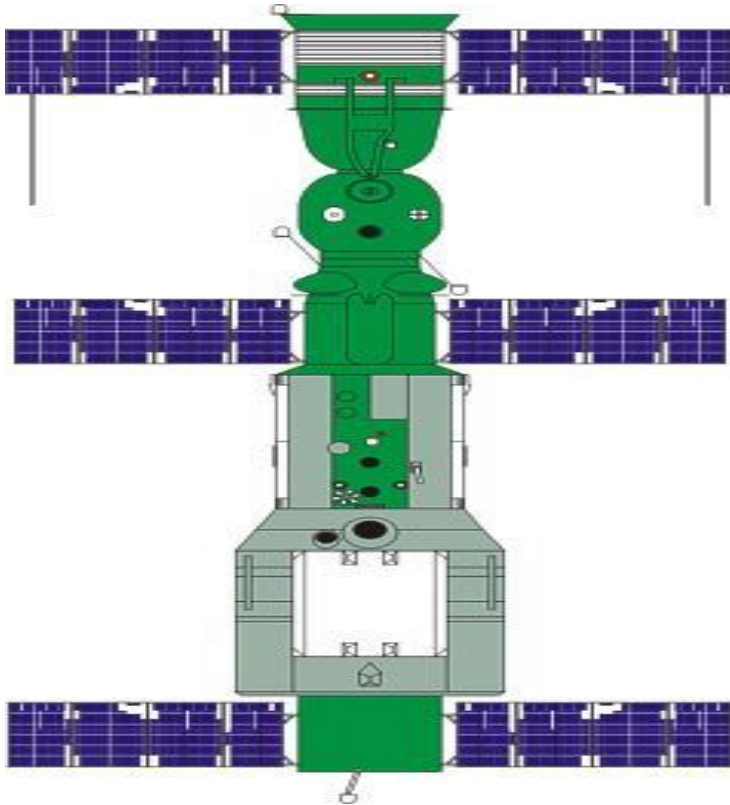

Salyut 1



- Soyuz 10 crew unable to board due to docking mechanism failure
- Soyuz 11 crew spent 23 productive days on orbit
- Tragedy on reentry

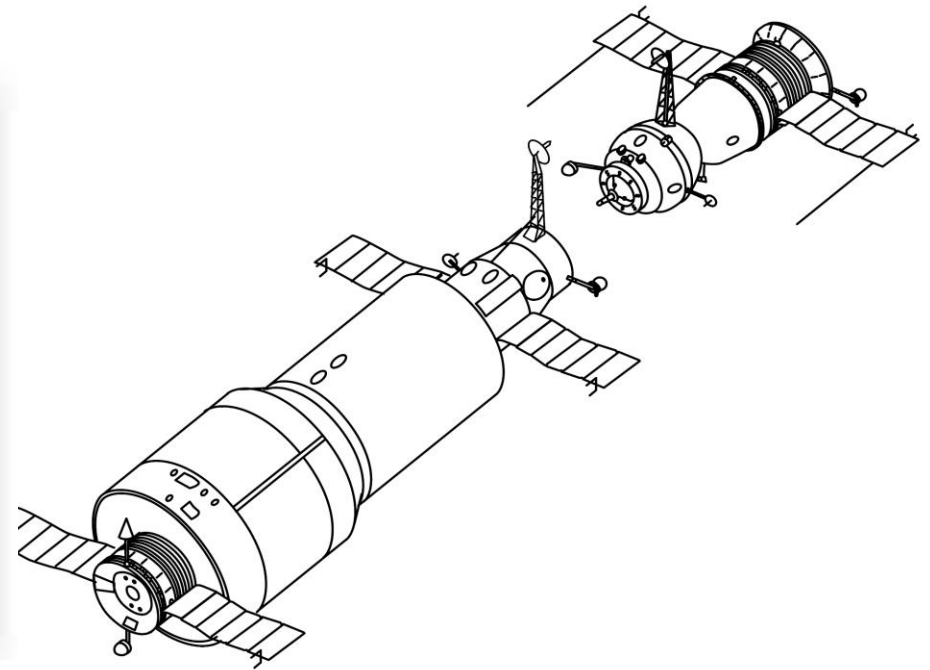

Salyut 1



- First space station crew died during Soyuz 11 reentry on 24th day in space secondary to decompression on June 30, 1971. It was de-orbited in October 1971 before it could be revisited.
- Valve failure (beneath seats) at time of descent module separation leading to depressurization at approx 168km altitude with crew death within approx 40 seconds. No pressure suits due to vehicle size limits.

Salyut 1



Salyut 1 Crew



Salyut 2



- Launched April 4, 1973
- Salyut 2 was never crewed due to depressurization and flight control failure after achieving orbit



Skylab—NASA's First Space Station (1973-74)

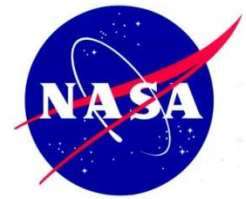

Skylab 2 (May 25, 1973) was the first NASA space station mission

28 days in space

Dr Joe Kerwin, Pete Conrad, Paul Weitz



Skylab—NASA's First Space Station (1973-74)



Skylab 3 (July 28, 1973) was the first long duration crew in history—59 days in space

Owen Garriott, Jack Lousma, Al Bean

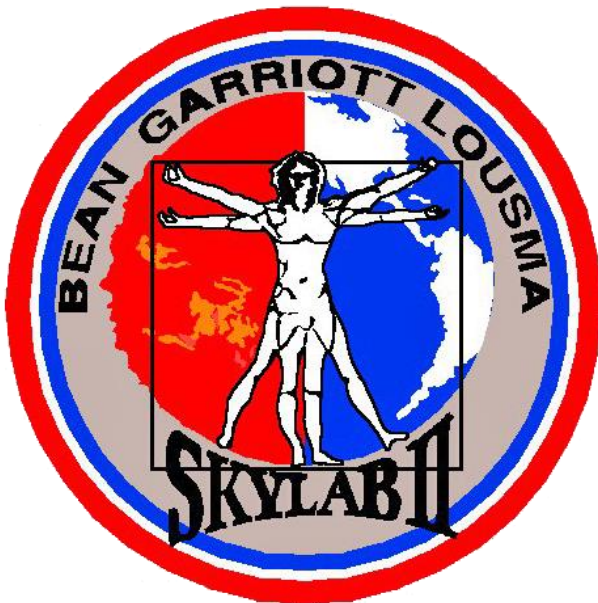

Skylab—NASA's First Space Station (1973-74)



Skylab 4 (November 16, 1973) was the second long duration crew in History—84 days in space

Gerald Carr, William Gibson, Edward Pogue



Salyut 3

Launched June 25, 1974

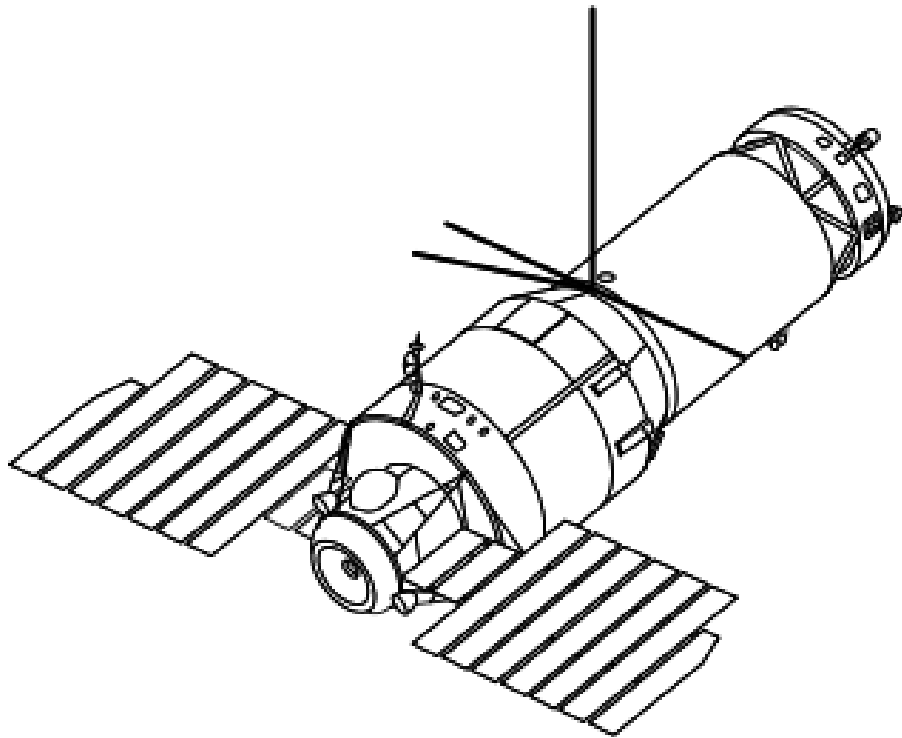

Days in orbit 213

Days occupied 15

Salyut 4 (1974-77)



- First Russian long duration space mission (63 days) in 1975
- Two expeditions (3rd failed due to launch abort)

Salyut 4 Civilian Orbital Station

- 1 Soyuz manned transport craft
- 2 EVA/access hot (on side hidden in this illustration)
- 3 Rendezvous antenna
- 4 One of three steerable solar panels
- 5 Gas storage for life support system
- 6 Food and storage lockers
- 7 Attitude control jets
- 8 KTDU-35 main propulsion system
- 9 Rendezvous transponder
- 10 Propellant tanks for main propulsion system
- 11 OST-1 apparatus
- 12 Chibis lower body negative pressure suit
- 13 Treadmill
- 14 Table
- 15 Main control console
- 16 Forward bulkhead of work compartment
- 17 Spheres of pressurant gas
- 18 Television camera system

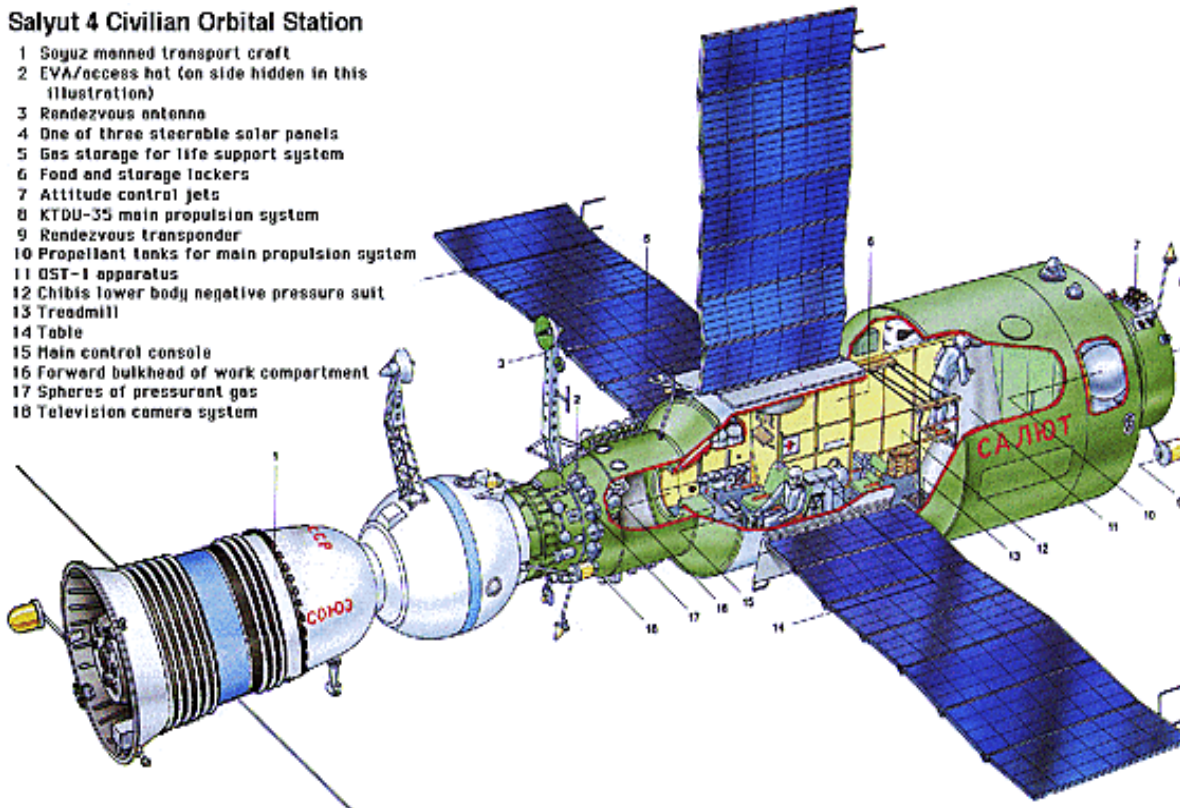

Salyut 5 (1976-77)



- The 49-day Soyuz 21 mission was launched in July 1976 (second Russian long duration mission)
- Two missions total—49 and 18 days

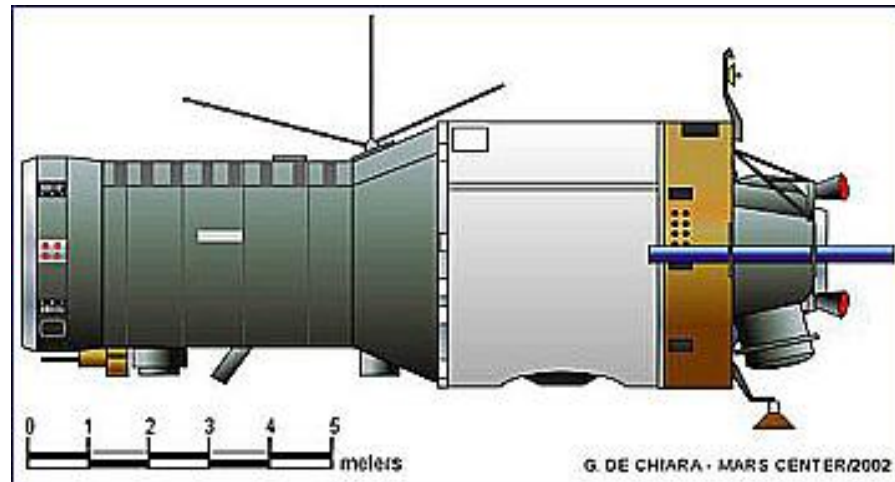

Salyut 6 (1977-82)



First Space Station involving ultra-long expeditions

"...All one needs to effect a murder is lock two men into a cabin, 18 feet by 20 feet, and keep them there for two months"

- Valerie Ryumin, Salyut 6

- 17 Expeditions 1977-1981
- Five long duration missions including 1980 EO-expedition of 185 days (first 6-month mission)
- Russian psychological support program begins due to signs of stress among cosmonauts during missions



Salyut 7 (1982-91)



- 12 Expeditions
- Six long duration missions
- EO-3 Expedition in 1984 of 237 days (8 months)
- Evidence of mission related stress continues to be noted



Salyut 7



- Soyuz T10-Salyut 7 (1985):
Crew reported possible visual hallucinations to mission control—never explained
- <https://www.youtube.com/watch?v=HzLjQ033Ptk>
- Soyuz T14-Salyut 7 (1985):
Depression may have contributed to early termination of the mission



Troitsyna, M. (2011, June 14). Angels in space nothing but top-secret hallucinations. *Pravda*.

Buckey, J. C., Jr. (2006). *Space Physiology*. Oxford University Press.

Mir (1986-2001)

First Modular Space Station



- 28 long duration missions
- 4 cosmonauts completed single missions greater than one year in duration
- Shuttle—Mir Program (1995-1998)
- Crewed continuously for 8 days shy of ten years (1989-1999)



Shuttle—Mir Crew Members 1995-1998



NASA's First Modern Era Long Duration Astronauts
NASA's Behavioral Health and Performance Group founded

Norman Thagard, Shannon Lucid, Dave Wolf
John Blaha, Jerry Linenger, Michael Foale, Andy Thomas



International Space Station (ISS) 2000—present



Tiangong-1 (Heavenly Palace 1) 2011 Deorbited April 2018

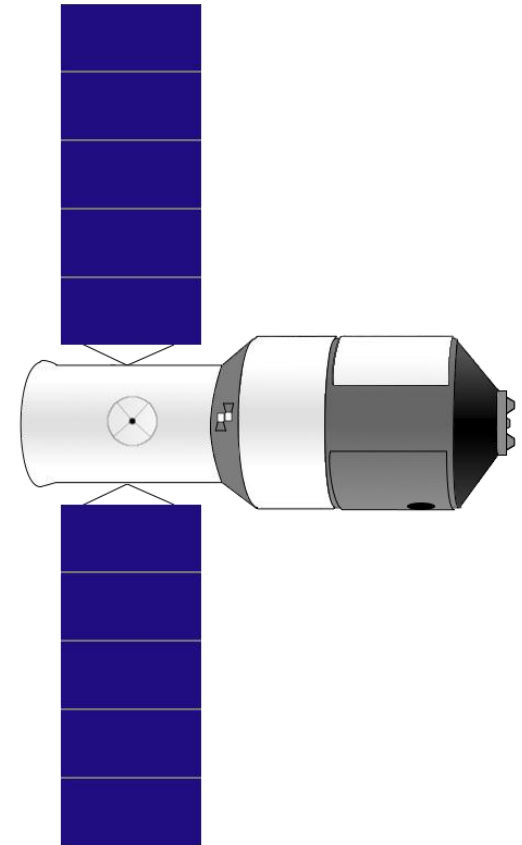

Tiangong-2 launch September 15, 2016



Deorbited June 2019



Tiangong Space Station

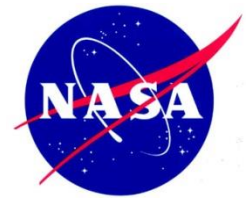

Launched April 29, 2021



Current and Prior Space Stations



Current orbital stations

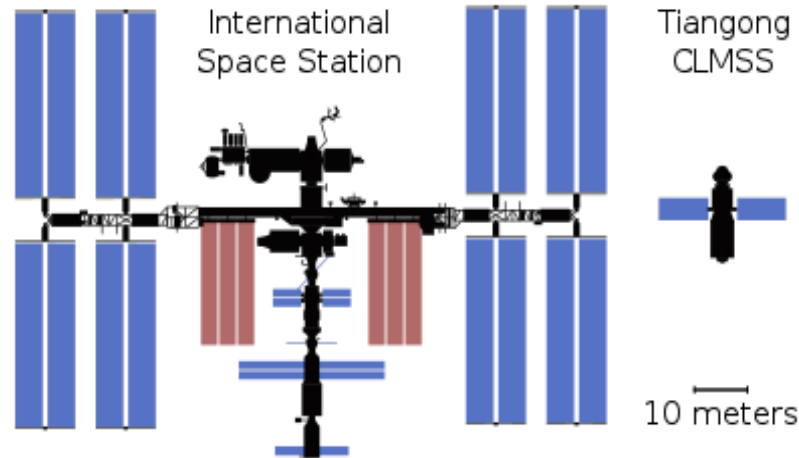

Past orbital stations

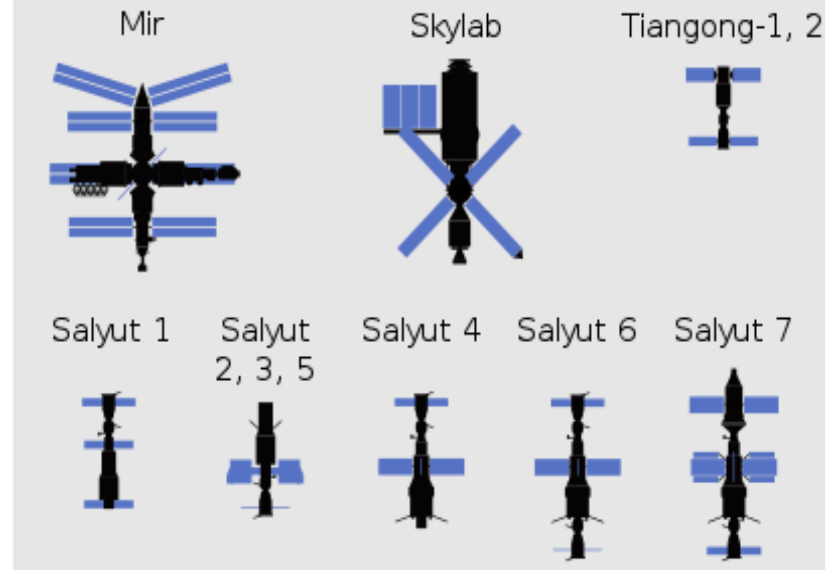

Future Commercial Space Stations



Blue Origin and Sierra Space Orbital Reef

Axiom Space Commercial Space Station

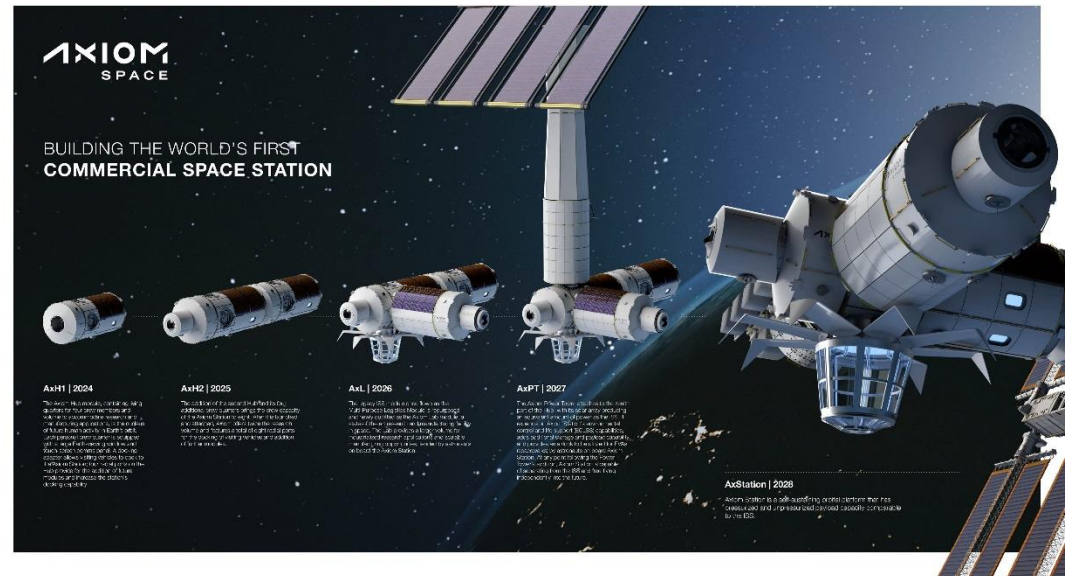

Valery Polyakov, MD



- Single spaceflight duration record holder—437.7 days on Mir
- January 1994 to March 1995
- Russian cosmonaut physician
- Two Mir missions totaling 679 days



Astronaut Scott Kelly NASA's first 1-year mission



Mark Vande Hei

NASA's second 1-year mission

- Soyuz landing March 2022 after 355 days on ISS



Cumulative time in space record holder



- Cosmonaut Gennady Padalka
- 879 days in space
- Five spaceflights
- Mir and 4 ISS Expeditions



Most cumulative time in space by a female and NASA record holder



- 3 ISS Long Duration Missions
- First female space station CDR
- First female and non-military chief of the NASA Astronaut Office
- 665 days, 22 hours, 22 minutes in space
- 10 EVA's; 60 hours, 21 minutes
- CDR of future Axiom 2 mission



Astronaut Peggy Whitson

With Peggy Whitson postflight following her 3rd ISS mission in 2017



Laika—first mammal in space

First orbital death

November 3, 1957



The first organisms sent to space were fruit flies launched on a V2 rocket by the US in 1947. They were also the first to return alive.

Spaceflight Deaths



18 crew deaths during spaceflight

- 1967 Soyuz 1—1 death
 - Trauma from Earth surface impact
- 1971 Soyuz 11—3 deaths
 - Asphyxia/fatal ebullism from cabin breach
- 1986 Space Shuttle Challenger—7 deaths
 - Trauma from explosions and surface impact (mission never reached space)
- 2003 Space Shuttle Columbia—7 deaths
 - Asphyxia from cabin breach and/or trauma from high G orbiter disintegration

Vladimir Mikhaylovich Komarov

First inflight fatality in history of spaceflight
April 23, 1967



Yuri Gagarin (left) and Vladimir Komarov out hunting



“He'll die instead of me. We've got to take care of him.”

Komarov talking about Gagarin

Soyuz 1 Impact Site



Primary and back-up chute failures: Drogue deployed;
primary chute failed to deploy; back-up chute deployed but
became entangled

Valentina Komarov, widow of Soviet cosmonaut Vladimir Komarov, kisses a photograph of her husband during his official funeral, held in Moscow's Red Square on April 26, 1967



Vladimir Komarov's remains in an open casket (from Soviet Archives)



Komarov chose to fly to protect Gagarin, and insisted before the flight that his funeral be open-casket so that the Soviet leadership could see what they had done

International Space Station

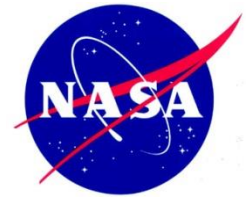

- ISS Basic Facts:

- Mass 924,739 pounds
- Habitable Volume: 13,696 cubic feet
- Module Length: 167.3 feet
- Truss Length: 357.5 feet
- Solar Array Length: 239.4 feet
- Power Generation: 8 solar arrays = 84 kilowatts
- Orbit—180 nautical miles
- Speed—17,239.2 mph (15.79 orbits per day)
- Estimated cost \$100 billion
- Continuously occupied since 2000



ISS Expedition 1 Crew 2000



NASA astronaut Bill Sheperd, the first ISS Commander with
cosmonauts Yuri Gidzenko and Sergei Krikalev



ISS 20 First Six Person Crew



Current Expedition 68 Crew 2022

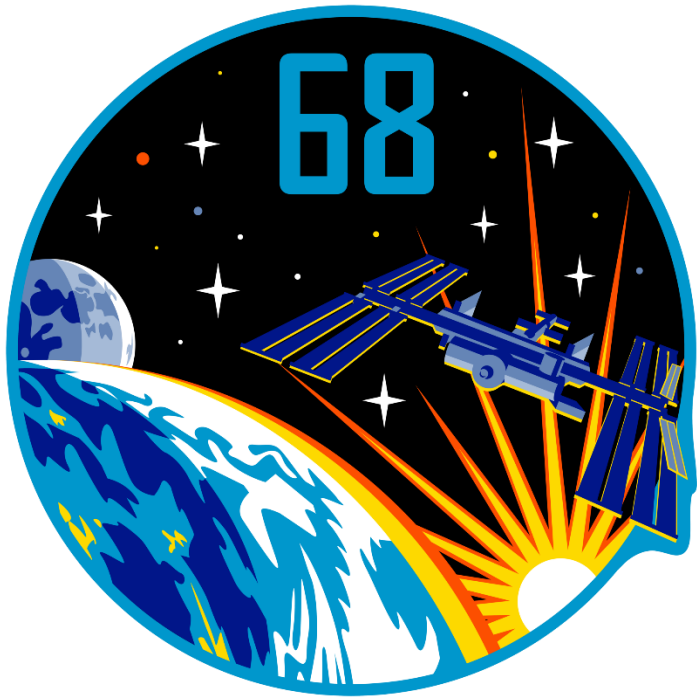

ISS launch vehicles: Russian Soyuz, SpaceX Dragon and Boeing Starliner



SpaceX Crew-3 Launch from KSC

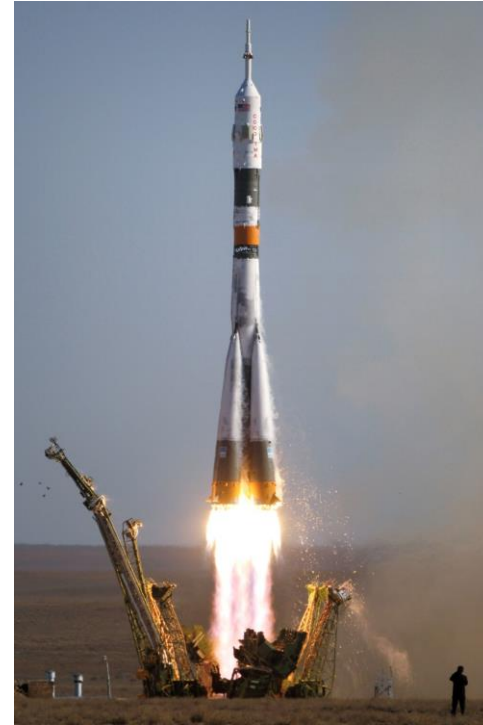

Russian Soyuz launch from Kazakhstan

Boeing Starliner and SpaceX Dragon

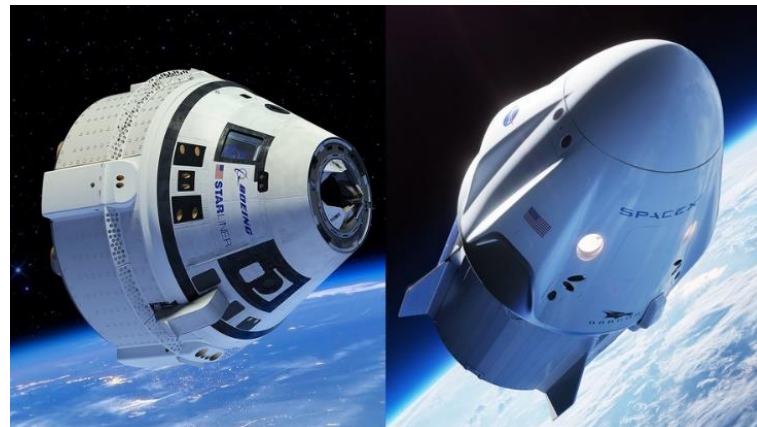

Long Duration Missions: Can be physically and emotionally exhausting



ESA Cosmonaut Jean-Pierre Haignere upon landing from Mir after 188 days

The Challenges of Long Duration Spaceflight



ISS 6 Crew recovery from Soyuz landing in Kazakhstan



Scott Tingle at ISS 55 Landing in Kazakstan June 3, 2018



Behavioral Health Impact of Long Duration Mission Stressors



- Long duration missions are **qualitatively** as well as **quantitatively** different from short duration missions
 - Stressors can gradually wear and tear on crewmembers
- Very similar to polar, undersea, military deployments
 - Normal people living in an abnormal environment



ISS: A unique work/living environment



- Special characteristics
 - Isolation and confinement
 - Privacy/habitability
 - Highly ground-commanded work environment
 - Managing relationships from a distance
 - Monotony in living environment and work tasks
 - Rotating international and diverse crews
 - Lighting/smell/noise level

International Space Station



How do you ensure optimal performance in an isolated operational environment where you both live and work?

ISS is an operational environment



Even under normal operations, events can occur and the preconditions for frustration and miscommunication are embedded



Reported Behavioral Issues During Spaceflight



- Three Soviet missions were aborted for reasons partly psychological (Salyut 6 and Salyut 7)
- A Salyut 7 Cosmonaut described severe irritability, anxiety, restlessness, and insomnia (admitted following mission completion)
- A NASA astronaut aboard Mir described feelings of isolation, alienation, and confinement; another reported symptoms of subclinical depression
- Delayed notification to a Russian crewmember of a family member's death led to acute social withdrawal, depression and isolation

“Space Fog”

- Anecdotally reported, subjectively experienced, cognitive decrement during spaceflight (long and short duration)
 - Not yet objectively measured
 - No clear operational impacts noted/measured
 - Reported by a minority of short and long duration crew members
 - Primarily noted during period of spaceflight acclimatization
 - Problems with concentration, short-term memory, multitasking abilities, organizational skills forcing need to ultra-concentrate and perform tasks slowly and deliberately
 - Not generally reported on ISS during period of mastery (after 4-6 weeks)
- Proposed comprehensive neurocognitive inflight study has just been awarded that may help to answer questions about this phenomenon.

“Spaceflight Asthenia”

initially noted during later Salyut missions

- Russian psychologists have identified a behavioral syndrome afflicting cosmonauts during previous long duration missions called “spaceflight asthenia”
- Asthenia has included the following characteristics:
 - Physical and emotional fatigue or weakness
 - Hypoactivity
 - Irritability and tension
 - Emotional lability
 - Appetite and sleeping problems
 - Attention and memory deficits
 - Withdrawal from others and territorial behavior
- Not thus far objectively identified in US ISS crewmembers. The question remains open as to whether or not asthenia occurs and if so whether its manifestations are affected by cultural factors

Kanas, N and Manzey D, *Space Psychology and Psychiatry*, 2003,
Microcosm Press & Kluwer Academic Publishers

What has not been reported as occurring during spaceflight



- Physical confrontation/aggression
- Major depression or suicidality
- Mania
- Delusions/psychosis
- Delirium (anoxia, head injury, illness)
- Panic attacks
- Use of psychiatric medication (e.g., antipsychotics or antidepressants)
- Intoxication or withdrawal
- Any other major psychiatric disorders (panic disorder, obsessive compulsive disorder, etc.)

International Consensus for ISS Behavioral Health and Performance Services



- BHP assessment services to all crewmembers is decided upon by international agreement
- The ISS Spaceflight Human Behavior and Performance Working Group (SHBPWG) meets annually to discuss and implement a common behavioral monitoring and countermeasures program for all ISS crewmembers

2016 SHBPWG at the Museum of Cosmonautics, Moscow





Why is behavioral health and performance support needed during ISS missions?



- ISS is a \$100 billion dollar investment
- No room for major errors in space
- Major mishap would bring human space program to a halt
- Knowledge of human performance optimization supports BHP program—importance of leisure, rest, interpersonal relationships, etc.
- Prepare for exploration beyond low earth orbit

Humans in space per year through 2011



number of humans launched into space
 peak altitude above 100 km (intended)

- private
- China
- USA
- USSR / Russia

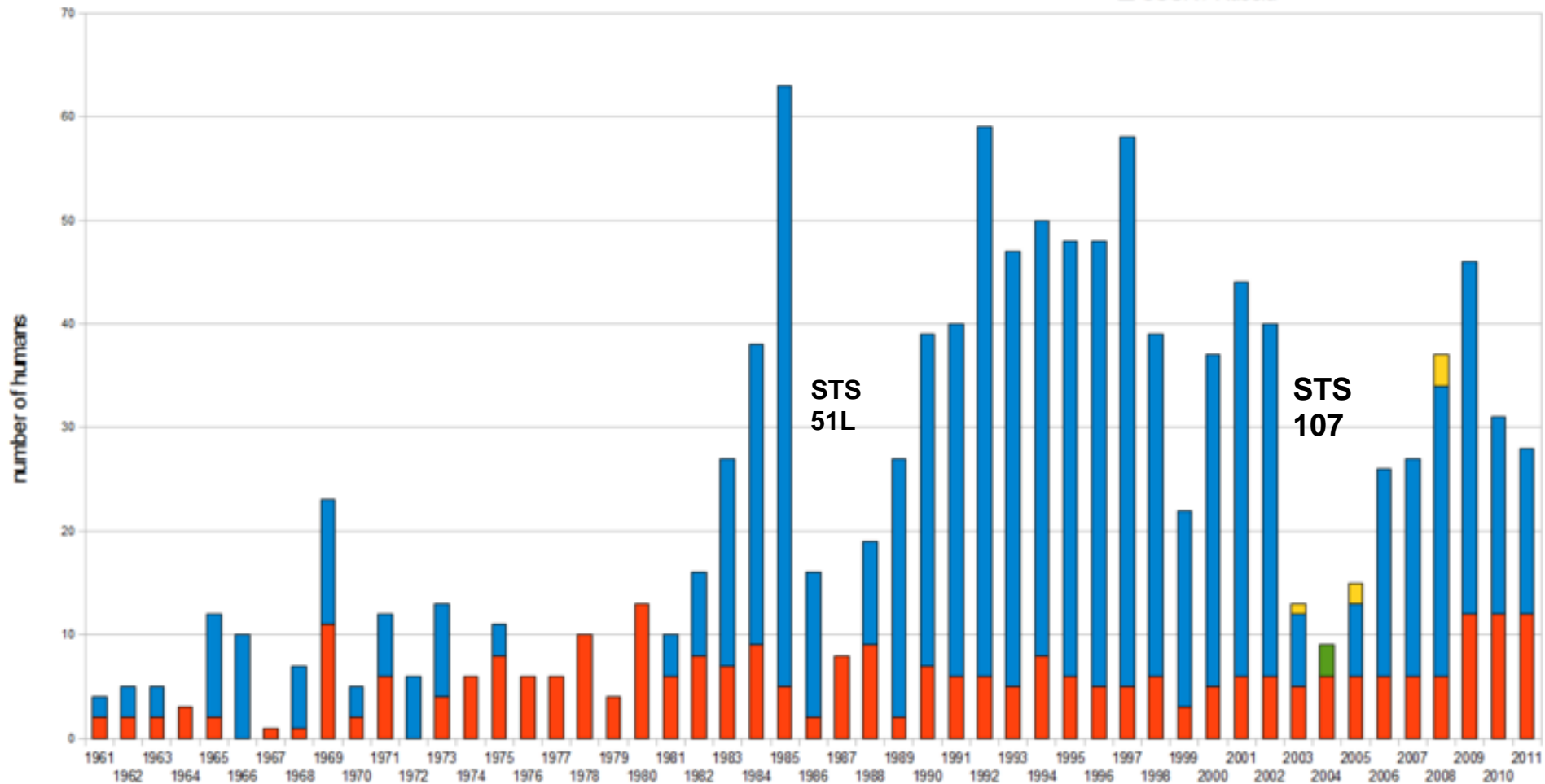



ISS BHP Operations Support Team

- 5 BHP Operations personnel assigned to each ISS crew member
- Specific and separate team for each ISS crew member
- Psychiatrist/flight surgeon and operational psychologist working as a team
- Psychologist for neurocognitive test training and analysis
- 2 psychological support providers—prime and backup

Get out of my head Dr Beven!

“Son, you gotta understand, the crews won’t be happy until the last psychologist has been strangled on the entrails of the last flight surgeon.”

– Skylab astronaut Dr Joe Kerwin to NASA psychologist Al Holland

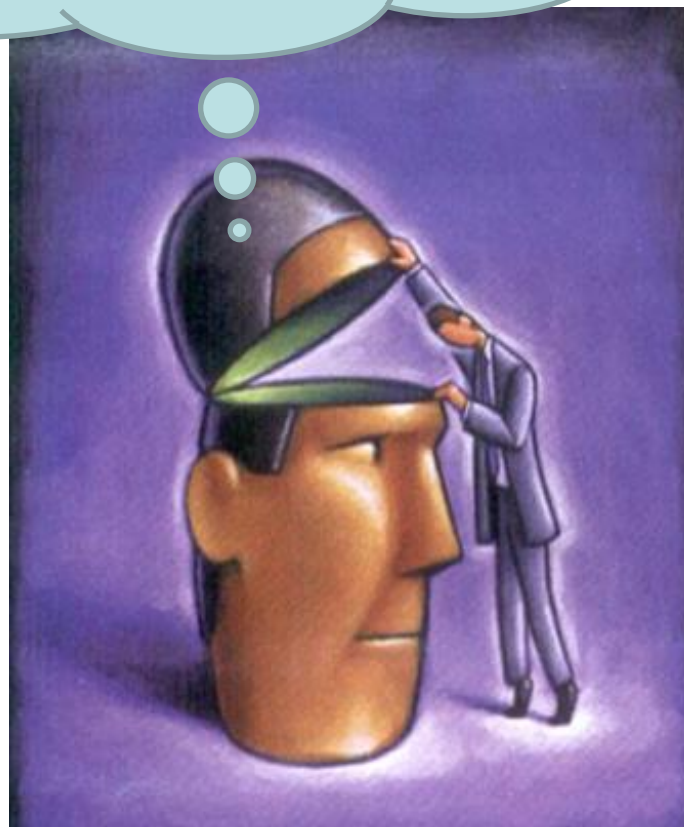

“Do you think you’re ready for your mission?”



ISS Mission Behavioral Medicine Components



- Annual behavioral health evaluations
- Pre-flight behavioral health readiness evals
- ISS Crew medical officer behavioral medicine training
- Inflight Private Psychological Conferences (PPCs)
- Inflight Cognition “surveillance” (WinSCAT)
- Post-flight evals and re-adaptation support



ISS Crew Medical Officer Training

- Highlights possible “worst case” scenarios—delirium, complicated bereavement, common symptoms of major mood and anxiety disorders, and familiarization with treatment options on the ISS
- Current ISS Med Kit Meds: aripiprazole (PO); ziprasidone (IM); sertraline; venlafaxine; diazepam (IM); lorazepam (PO); zolpidem; zaleplon; modafinil
- ISS crews would ordinarily provide any emergency or even routine behavioral interventions under real time guidance by the flight surgeon

Annual Astronaut Evaluation



- Summary of current NASA career status
- Professional training and workload
- Sleep, fatigue, mood
- Peer and management relationships
- Social and family life
- Greatest professional and personal challenges
- Primary goals for the coming year
- Brief MSE & Conclusions



Col Michael Hopkins

- ISS 38 crew and SpaceX crew-2 CDR
- USAF flight test engineer
- MS Aerospace Engineering, Stanford University
- Captain, U of Illinois Football Team



ISS Preflight Assessments (L-365/180/30)



- Principle pre-flight evaluation topics:
 - Training issues including perception of mission readiness
 - Training workload and fatigue levels
 - Family or personal relationship issues
 - Crew-crew training interactions, familiarity and concerns
 - NASA management issues or concerns
 - Mood and anxiety
 - Mission goals, desires, challenges and risks
 - Post mission rehabilitation or family concerns
 - Emergency notification method—bad news from whom?

Neurocognitive Assessment with WinSCAT

(Space Flight Cognitive Assessment Tool for Windows)



WinSCAT is a brief neurocognitive test that provides a baseline level of cognition. This baseline can be used following a neurological injury on the ISS to judge severity and gage recovery



Neurocognitive Assessment with WinSCAT

Activity	Duration	Preflight	In Flight	Postflight
Training	60 minutes	L-120 days		
Neurocognitive Assessment Baseline (MAT)	60 minutes	L-100 days		
	45 minutes	L-90 days		
	30 minutes	L-60, L-30, L-7 days		
Routine Monitoring	30 minutes		Every 30 days	
Postflight	30 minutes			R+14*, R+30 days * If clinically indicated

- Subtests of WinSCAT are from the Automated Neurological Assessment Metrics (ANAM)
 - ANAM has been used extensively in neuropsychological research and is the result of 30+ years of psychological test development by the US Dept. of Defense
- In 11 to 15 minutes, WinSCAT assesses:
 - response time
 - sustained attention/concentration
 - visual working memory
 - verbal working memory

WinSCAT Subtests



- CDS – Code Substitution
 - Learning
- CPT – Continuous Processing Task
 - Sustained attention and concentration
- MTH – Mathematics
 - Verbal working memory
- MTS – Matching To Sample
 - Visual short-term memory
- CDL – Code Substitution Delayed
 - Delayed recall

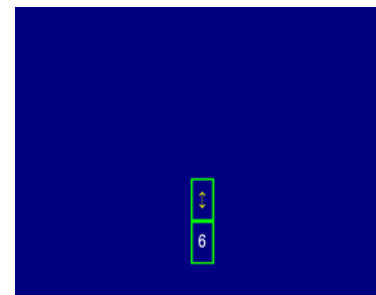
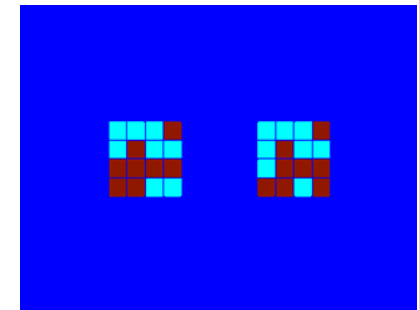
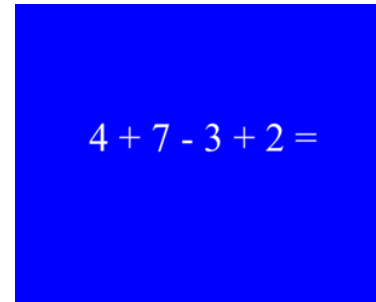
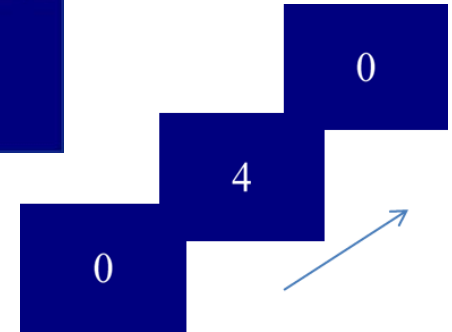
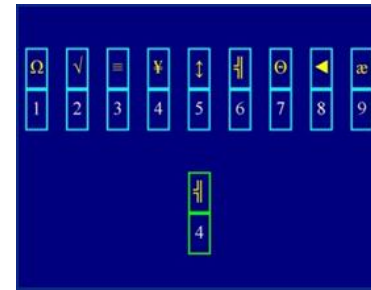



Private Psychological Conference (PPC's)



- The Russians developed the PPC as a standard psychological countermeasure beginning with Salyut 6 and continued to use them on Salyut 7 and Mir
- NASA began using PPC's during Shuttle-Mir in 1995 with Dr Holland and astronaut Norm Thagard
- Performed every two weeks during ISS expeditions (all crew members)
- Private video conference between the ISS astronaut and the NASA psychiatrist or psychologist that ordinarily takes place on the weekend
- Typically lasts 15-20 minutes depending on subject matter discussed and mission phase
- Contents are non-recorded private and confidential medical events

ISS Private Psychological Conferences (PPC's)



- The following topics are covered each PPC and these reflect the main clinical/operational concerns:
 - Sleep (duration and quality) and sleep shift issues
 - Fatigue level
 - Workload and pace of work
 - Individual and crew morale
 - Crew relationships
 - Crew-ground relationships
 - Mood
 - Cognition
 - Family and personal relationships
 - Environment and habitability issues, including food
 - Operational psychology issues or requests
 - Preparation for important tasks, such as EVA's

ISS Postflight Assessment

R+3; R+14; R+30-45



- Principle post-flight evaluation topics:
 - Mission in retrospect—level of personal satisfaction
 - Greatest challenges, frustrations, joys during the mission
 - Retrospect review of fatigue level prior to critical events such as EVA's
 - Family reintegration issues
 - Postflight mood, anxiety and cognition
 - What are short and long-term career plans?
 - What worked and didn't work from a BHP standpoint?
 - What BHP services need improvement or change?

Scott Kelly with Drs Holland, Picano and Beven at R+60 eval



Al Holland and Gary Beven with Scott Tingle at R+3 in Houston after his 168-day mission





Behavioral Support Services



- Direct psychological support services for ISS Crews and Families
- Meetings and briefings with crew member and family begin just after assignment—approximately 18 months years before flight
- All products are optional private, personalized and provided via individualized, concierge—like service

Internet Phone (IP Phone)



- The IP Phone runs on a software program that is dependent on KU-Band satellite coverage
- There are currently 8 units on ISS
- Can be used as non-scheduled communication
- Using the IP Phone ISS crewmembers can dial any number in the world but can not receive calls



Expedition 4 Flight
Engineer, Carl Waltz, using
the IP Phone

Private Family Conferences (PFC)



- Family communication is facilitated through the use of e-mail, IP Phone and two-way video teleconferences
- Video Private Family Conferences (PFC's) are scheduled on a weekly basis
- Laptop or tablet with video camera in use since ISS 28



Equipment in the home



Astronaut Clay Anderson
conducting a PFC onboard ISS



Front Page Photo

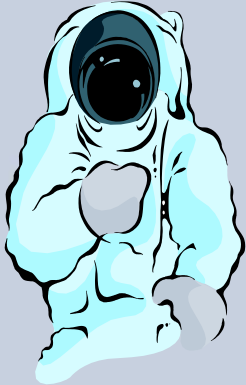

Expedition XX

- [Home](#)
- [Books](#)
- [Greetings](#)
- [Internet Radio](#)
- [Magazines](#)
- [Miscellaneous **NEW**](#)
- [Movies](#)
- [News **NEW**](#)
- [Odd News](#)
- [Movie Library](#)
- [Personal Videos](#)
- [Photo Album](#)
- [Podcasts](#)
- [Special Dates to Remember](#)
- [Sports Video](#)
- [Personal Music](#)
- [TV Programs](#)
- [Notre Dame](#)
- [Weather](#)

Recent Photo News



17/30

SAN FRANCISCO, CA - OCTOBER 22: Angel Pagan #16 of the San Francisco Giants is tagged out by catcher Yadier Molina #4 of the St. Louis Cardinals in the seventh inning in Game Seven of the National League Championship Series at AT&T Park on October 22, 2012 in San Francisco, California.



ISS Private Special Conferences (PSC's) 6 allotted per mission



- Expedition 5 – Peggy Whitson talks with friends in the NASA offices in Star City, Russia



Crew Discretionary Events (CDE's)

2 allotted per mission



- Private video contacts with celebrities such as actors, professional athletes, authors, comedians, etc., for the purpose of building crew morale. These are private events and not publicized.
- Who would you choose to meet with?



Care Packages and Crew Supply Cargo



Crew Care Packages (CCP)



Astronaut Jeff Williams, Expedition 13, opening a CCP on-orbit.

Holidays in Space

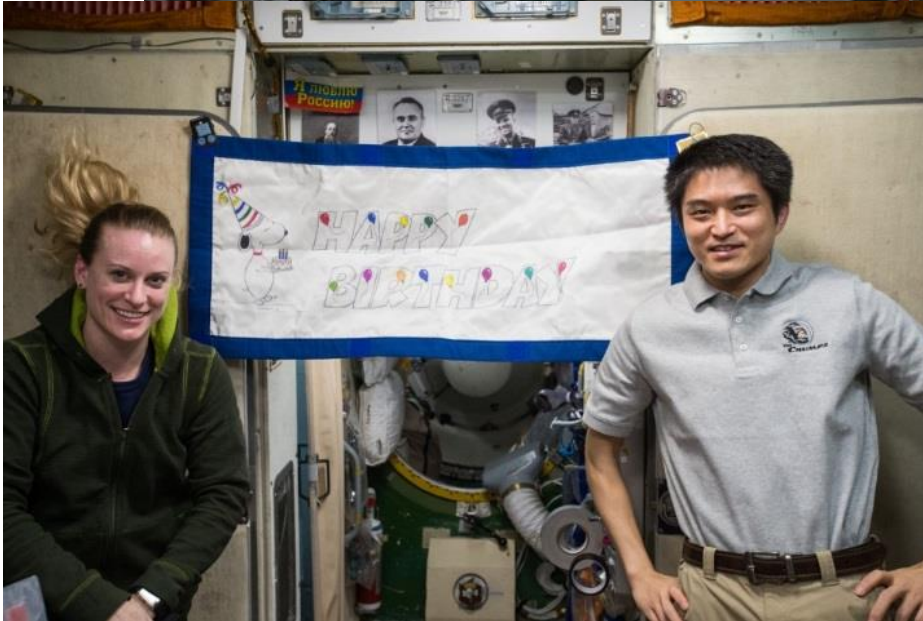

Music for recreation on ISS remains popular



Expedition 3 – Frank Culbertson playing trumpet



ISS003E5802 2001/09/16 13:26:39

Expedition 5 – Treschev playing the ISS guitar



Space jam during ISS Exp 56



Expedition 4- Carl Walz playing the ISS keyboard

Screen and Hi-Def Projector launched on SpX-6 (4/14/2015)

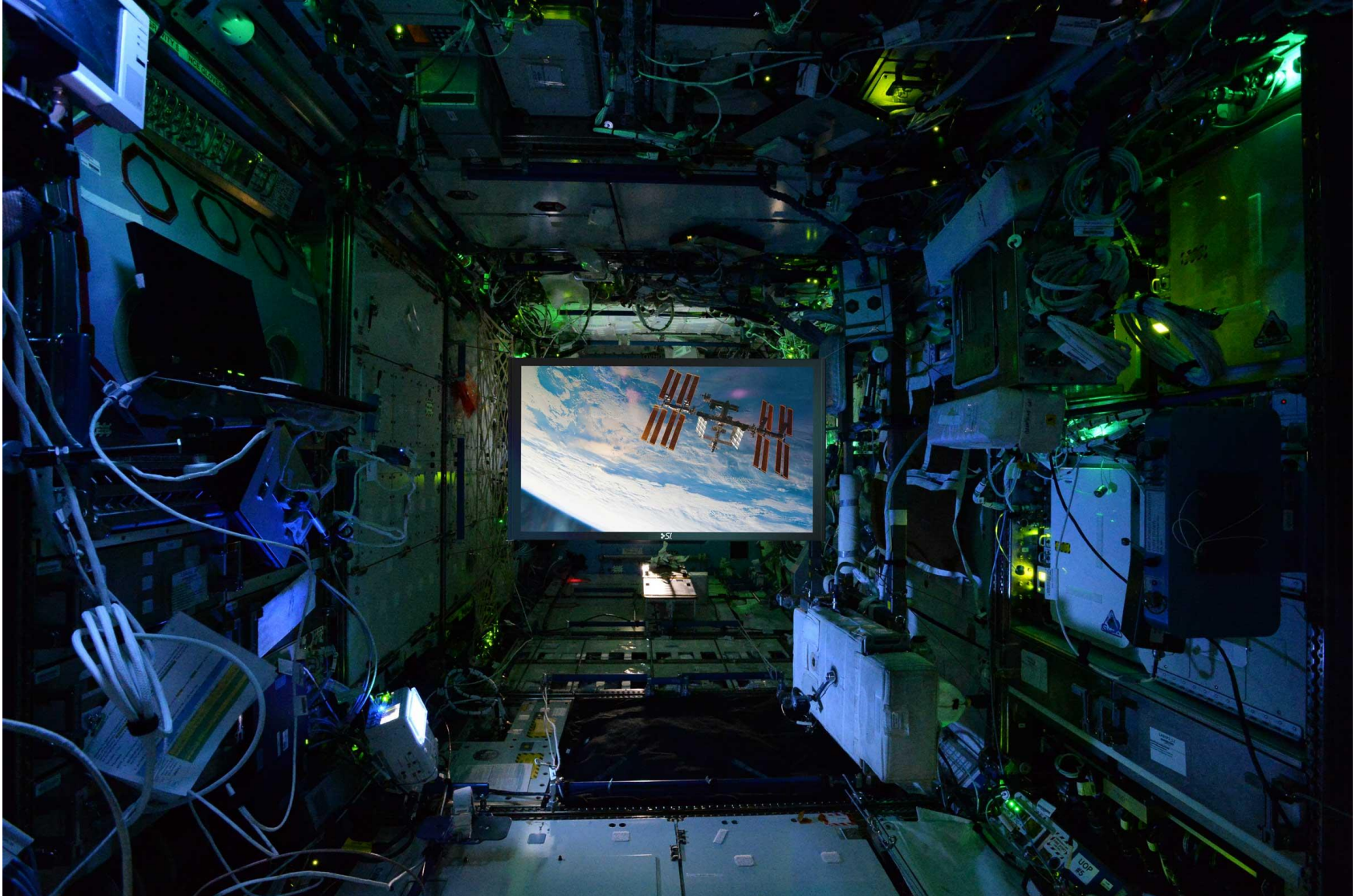

Movies in Space

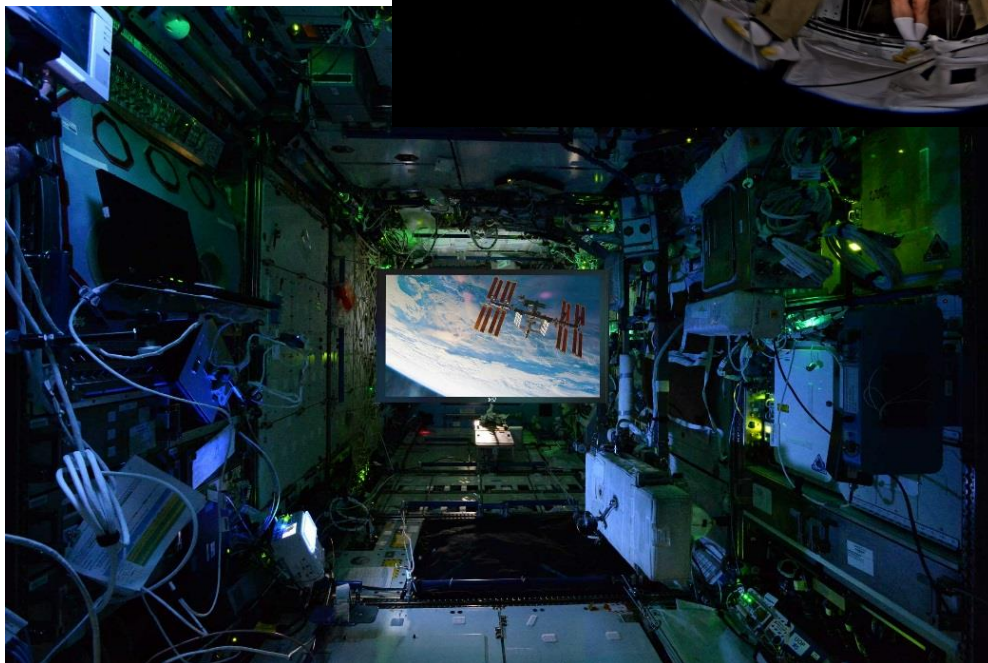

TV Schedule



TV Schedule	
	The Travel Channel
	Oxygen
	Bravo
	USA Network
	VH1
	Pivot
	WGN America
	KTRK
	Food Network
	Lifetime
	The Learning Channel
	TV Land
	H2

06/24/2015

06/25/2015

06/26/2015

Time	Title	All Episodes	
01:00	Vietnam in HD -- A Changing War (1969-1970); Peace with Honor (1971-1975)	<input type="checkbox"/>	Record
03:00	Ultimate Secrets of Time	<input type="checkbox"/>	Record
03:30	Ultimate Secrets of Luck	<input type="checkbox"/>	Record

Astronaut Tracy Dyson in the Cupola What will replace this on a Mars mission?



ISS Photography—a favorite hobby for many

Will this be as popular on the way to Mars?



Exercise is a vital crew morale
countermeasure

Astronaut Nicole Stott on ISS
treadmill during ISS 21 in 2009



Dinner on ISS

Communal meals are an important aspect of crew cohesion





Spaceflight Behavioral “Worst Case” Scenarios



- Death of family member on earth (especially that of a child)
- Illness or injury leading to behavioral instability (eg, delirium)
- Mishap during space operations due to human error caused by extreme fatigue or insufficient sleep
- Development of severe depression, anxiety, psychosis or other significant behavioral health symptoms
- Significant crew-crew interpersonal conflict
- Significant crew-ground conflict that turns into an overt “us against them” scenario

The Future—Mars and other Exploration Missions

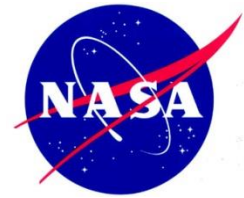

- Much greater distance and mission length—250 million miles and 2.5 years
 - Crew make-up (number, gender mix, age ranges, technical skills)
 - Living space and privacy
 - Crew selection—personality style and relationships
 - Analog testing of prime and back-up crew (ISS, Antarctica, isolation chamber, etc.)
 - Family support challenges
 - Training of Crew Medical Officer in advanced behavioral health diagnosis and treatment
 - Autonomous behavioral health diagnostic testing and countermeasures
 - Operational psychology support suite (exercise, movies, music, education, family contact)
 - Insidious neurocognitive response to space radiation exposure
 - Behavioral response to isolation and confinement (depression/anxiety)
 - Crew conflict and compatibility—early detection and intervention



If you remain interested

Aerospace Medical Association



www.asma.org

Space Medicine Association

www.spacemedicineassociation.org

gary.beven-1@nasa.gov