

NASA/TM—20220017278

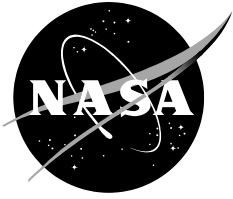

Single-Event Effect Radiation Test Report of the Infineon IRF5NJ9540 p-Type Power MOSFET

Jason M. Osheroff

November 2022

NASA STI Program Report Series

The NASA STI Program collects, organizes, provides for archiving, and disseminates NASA's STI. The NASA STI program provides access to the NTRS Registered and its public interface, the NASA Technical Reports Server, thus providing one of the largest collections of aeronautical and space science STI in the world. Results are published in both non-NASA channels and by NASA in the NASA STI Report Series, which includes the following report types:

- TECHNICAL PUBLICATION. Reports of completed research or a major significant phase of research that present the results of NASA Programs and include extensive data or theoretical analysis. Includes compilations of significant scientific and technical data and information deemed to be of continuing reference value. NASA counterpart of peer-reviewed formal professional papers but has less stringent limitations on manuscript length and extent of graphic presentations.
- TECHNICAL MEMORANDUM. Scientific and technical findings that are preliminary or of specialized interest, e.g., quick release reports, working papers, and bibliographies that contain minimal annotation. Does not contain extensive analysis.
- CONTRACTOR REPORT. Scientific and technical findings by NASA-sponsored contractors and grantees.
- CONFERENCE PUBLICATION. Collected papers from scientific and technical conferences, symposia, seminars, or other meetings sponsored or co-sponsored by NASA.
- SPECIAL PUBLICATION. Scientific, technical, or historical information from NASA programs, projects, and missions, often concerned with subjects having substantial public interest.
- TECHNICAL TRANSLATION. English-language translations of foreign scientific and technical material pertinent to NASA's mission.

Specialized services also include organizing and publishing research results, distributing specialized research announcements and feeds, providing information desk and personal search support, and enabling data exchange services.

For more information about the NASA STI program, see the following:

- Access the NASA STI program home page at <http://www.sti.nasa.gov>
- Help desk contact information:

<https://www.sti.nasa.gov/sti-contact-form/> and select the "General" help request type.

NASA/TM—20220017278

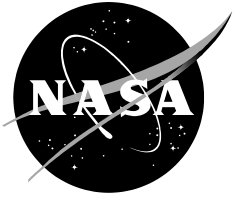

Single-Event Effect Radiation Test Report of the Infineon IRF5NJ9540 p-Type Power MOSFET

Jason M. Osheroff
Goddard Space Flight Center, Greenbelt, MD

Test Date: 9/7/2022
Report Date: 10/7/2022

National Aeronautics and
Space Administration

Goddard Space Flight Center
Greenbelt, MD 20771

November 2022

Acknowledgments (optional)

This work was sponsored by the NASA GSFC Radiation Effects and Analysis Group and supported by the On-Orbit Servicing, Assembly and Manufacturing (OSAM-1) mission.

Trade names and trademarks are used in this report for identification only. Their usage does not constitute an official endorsement, either expressed or implied, by the National Aeronautics and Space Administration.

Level of Review: This material has been technically reviewed by technical management.

Available from

NASA STI Program
Mail Stop 148
NASA's Langley Research Center
Hampton, VA 23681-2199

National Technical Information Service
5285 Port Royal Road
Springfield, VA 22161
703-605-6000

This report is available in electronic form at
<https://radhome.gsfc.nasa.gov/>

I. Introduction and Summary of Test Results

This study was undertaken to determine the single-event effect susceptibility of the IRF5NJ9540 p-channel power MOSFET from Infineon. Heavy-ion testing was conducted at the Texas A&M University (TAMU) Cyclotron. The application voltage of interest for this test is $V_{DS}=28V$ and 133% of the application voltage is $V_{DS}=37.24V$.

Samples passed above the required application drain voltage at 25, 30, 40 and 45V (V_{DS}) under irradiation with 15 MeV/u silver (linear energy transfer (LET) = $44.9 \text{ MeV}\cdot\text{cm}^2/\text{mg}$) with gate bias at 0V. All samples showed failure when irradiated with a drain bias of 50V. While the parts showed leakage current steps under irradiation at $V_{DS}=50V$, they failed catastrophically during post irradiation gate and drain stresses. Tests were conducted at normal beam incidence (worst-case angle) in air.

DUT #	LDC	25V	30V	40V	45V	50V
551	0551	✓	-	-	-	✗
001	1715	-	✓	✓	-	✗
008	1715	-	✓	✓	✓	✗
009	1715	-	✓	✓	✓	✗

Figure 1. Maximum passing V_{DS} bias during irradiation. Red ‘x’ indicates a failed part

II. Devices Tested

The sample size for this testing was 4 pieces at the TAMU facility. The part is manufactured by Infineon. The part is a -100V Single P-Channel Hi-Rel MOSFET in a SMD-0.5 package, part # IRF5NJ9540. Three flight Lot (LDC-1715) samples were provided by L3 in August 2022 in SMD 0.5 packages. One additional sample (LDC-0551) was also made available for testing. The pieces were mechanically de-lidded and visually inspected at GSFC prior to shipping to test facilities. At the test facilities, a subset of electrical characterizations was performed in the irradiation position prior to radiation exposure.

III. Test Facilities

Facility: Texas A&M University (TAMU) Cyclotron Facility, 15 MeV/u tune.
Flux: $1 \times 10^4 \text{ ions}/\text{cm}^2/\text{s}$.
Fluence: All tests were run to $1 \times 10^6 \text{ ions}/\text{cm}^2$.
Ion species: Ag. The table below shows the TAMU-provided beam energy and surface-incident beam properties.

Table 1. Ion Beam Properties (in air 3 cm from window)

Ion:	Energy (MeV)	Surface LET (MeV·cm ² /mg)	Range (μm)	Angle of Incidence (Degrees)
¹⁰⁹ Ag	1634	44.9	111	0

IV. Test Setup

The test circuit and block diagram, as shown in Figures 2 and 3, for the power MOSFET contains a Keithley 2635A source meter to provide the gate voltage (set to 0 V during irradiation) while measuring the gate current. A filter is placed at the gate node of each device under test (DUT) to dampen noise at the gate. A Keithley 2657A source meter provides the appropriate V_{DS} while measuring the drain current; a 500 Ω resistor is optionally switched into series with the Keithley 2657A to protect it from sudden high-current transients; it is switched out during device characterization tests. A Keithley 2657A-PM-200 diode-based protection unit prevents damage to the 2635A in the event of DUT failure shorting the supplies together. Gate current is limited to 1 mA, drain current limited to 100 mA, and both are recorded via ethernet to a desktop computer at approximately 175 ms intervals. All equipment is plugged into a power conditioner.

Six DUTs can be mounted on the test board via daughter cards and individually accessed via dry Reed relays controlled by an Agilent DAQ 34907A data acquisition/switch unit. All terminals of the devices not under test are then floating. Testing was conducted in air with the DUT centered within the beam diameter 3 cm from the window. Ion exposures were conducted at 0° tilt angle (normal incidence to the DUT).

The test setup is controlled via a custom LabVIEW program written by Alyson Topper and Hak Kim, Science Systems and Applications, Inc. The program controls the source measuring units (SMUs), gate current limit, and gate and drain current sampling and recording. It is designed to send LUA scripts to the Keithleys to perform a parametric analysis of each DUT prior to irradiation and following each beam run, recording if selected: gate threshold voltage (V_{th}), I_D as a function of V_{GS} at various fixed V_{DS} values for evaluation of total ionizing dose effects, drain-source breakdown voltage (BV_{DSS}), zero gate voltage drain current (I_{DSS}), and I_G and I_D as a function of V_{GS} (post-irradiation gate stress (PIGS) test to test the integrity of the gate dielectric).

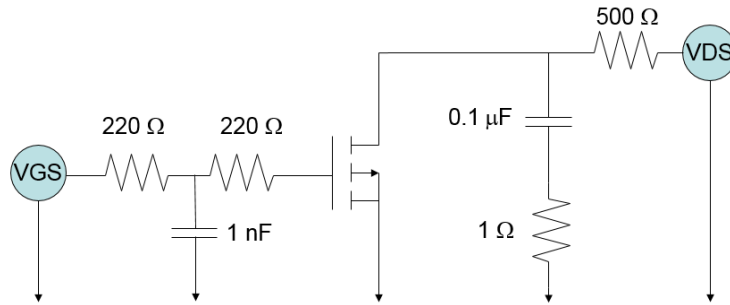

Figure 1. Equivalent test circuit for the IRF5NJ9540 p-channel power MOSFET

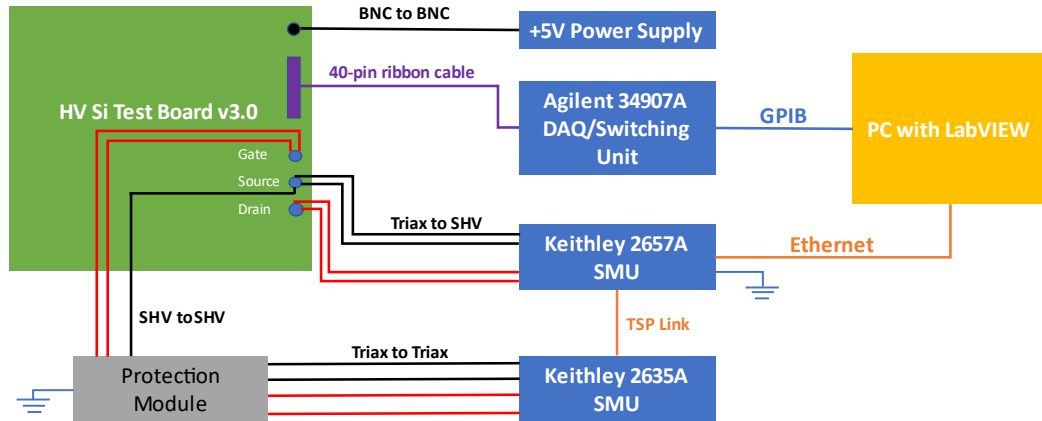

Figure 2. Block diagram of test setup.

V. Test Results

Following each run, the zero gate voltage drain current (I_{DSS}) was measured to test the integrity of the drain-source connection, and a gate stress test was performed in which the gate and drain currents were measured while at a fixed 0 V_{DS}, the gate voltage was swept from 0 V to 20 V, then from 0 V to -20 V, in 2 V increments. The +/- 20-V levels were held for 1 s to stress the gate per MIL-STD_750-1 TM1080.1 Condition B. Note that the gate stress test, per TM1080.1, is not performed when the gate is biased $\geq 50\%$ of rated voltage. Failure was defined as the gate current exceeding the manufacturer gate-source leakage current (I_{GSS}) specification of $-25 \mu\text{A}$ during the beam run or during the post-irradiation gate stress (PIGS) test, and/or a sudden, sustained increase in the drain current during the beam run indicative of single event burnout (SEB).

Given the limited beamtime available the device from LDC-0551 was used as a canary in coarse steps of 25V. All flight lot devices (LDC-1715) passed above 133% of the application voltage. Failure of all devices was observed after irradiation at $V_{DS}=50\text{V}$ with $V_{GS}=0\text{V}$.

Appendix A

Table A1. Manufacturer-Specified Electrical Parameters (Partial List)

Parameter	Condition	MIN	MAX	Units
Gate Threshold Voltage (V_{Gsth})	$V_{DS} = V_{GS}, I_D = -250\mu A$	-2	-4	V
Zero Gate Voltage Drain Current (I_{DSS})	$V_{DS} = -80 V, V_{GS} = 0 V$		-25	μA
Drain-Source Breakdown Voltage (BV_{DSS})	$V_{GS} = 0 V, I_D = -250\mu A$	-100		V
Gate-Source Leakage Current (I_{GSS})	$V_{GS} = +/- 20 V, V_{DS} = 0 V$		+/-100	nA
Static Drain-Source Resistance ($R_{DS_{on}}$)	$V_{GS} = -10 V, I_D = -11 A$		0.117	Ω
Forward Voltage (V_{SD})	$I_S = -18 A, V_{GS} = 0V$		-1.6	V

Appendix B

Table B1. Raw test data from 7 September 2022
(Tests in air; ion characteristics per TAMU Beam List)

Test Facility:	TAMU				In Air									flux:	1.00E+04			
Test Date:														fluence:	1.00E+06			
Device:	IRF5NJ9540													exp time (min:sec)	1:40			
Device ID:	REAG 22-016																	
Test Personnel:	Jason Osheroff																	
RUN INFO			DUT SETUP		BEAM DIAGNOSTICS: For Si										PRE-RUN CURREN		IRRADIATION RESULT	
Run	DUT	Socket	V _{GS} [V]	V _{DS} [V]	Ion	Energy [MeV/u]	Energy [MeV]	Angle	LET [MeV-cm ² /mg]	Flux [/(cm ² -s)]	Fluence [/(cm ²)]	Cum Fluence [/(cm ²)]	Dose [rad(Si)]	Cum. Dose (rad(Si))	Pre ID	Pre IG	SEE Observation on Run	
1	551	1	0	25	Ag	15	1634	0	44.90	1.00E+04	1.00E+06	1.00E+06	718	7.184E+02	12n	100f	only charge collection	
2	551	1	0	50	Ag	15	1634	0	44.90	1.00E+04	1.00E+06	2.00E+06	718	1.437E+03	13n	100f	~20n leakage event	
3	551	1	0	75	Ag	15	1634	0	44.90	1.00E+04	1.00E+06	3.00E+06	718	2.155E+03	884u	884u	stoped before run	
4	1	2	0	30	Ag	15	1634	0	44.90	1.00E+04	1.00E+06	1.00E+06	718	7.184E+02	10n	6p	only charge collection	
5	1	2	0	40	Ag	15	1634	0	44.90	1.00E+04	1.00E+06	2.00E+06	718	1.437E+03	10n	7p	only charge collection	
6	1	2	0	50	Ag	15	1634	0	44.90	1.00E+04	1.00E+06	3.00E+06	718	2.155E+03	11n	12p	~40n leakage event	
7	1	2	0	50	Ag	15	1634	0	44.90	1.00E+04	0.00E+00	3.00E+06	0	2.155E+03	1m	1m	stoped before run	
8	8	3	0	30	Ag	15	1634	0	44.90	1.00E+04	1.00E+06	1.00E+06	718	7.184E+02	10n	100f	only charge collection	
9	8	3	0	40	Ag	15	1634	0	44.90	1.00E+04	1.00E+06	2.00E+06	718	1.437E+03	10n	100f	only charge collection	
10	8	3	0	45	Ag	15	1634	0	44.90	1.00E+04	1.00E+06	3.00E+06	718	2.155E+03	10n	100f	only charge collection	
11	8	3	0	50	Ag	15	1634	0	44.90	1.00E+04	1.00E+06	4.00E+06	718	2.874E+03	11n	200f	~100n leakage event	
12	9	4	0	30	Ag	15	1634	0	44.90	1.00E+04	1.00E+06	1.00E+06	718	7.184E+02	11n	2p	only charge collection	
13	9	4	0	40	Ag	15	1634	0	44.90	1.00E+04	1.00E+06	2.00E+06	718	1.437E+03	11n	5p	only charge collection	
14	9	4	0	45	Ag	15	1634	0	44.90	1.00E+04	1.00E+06	3.00E+06	718	2.155E+03	11n	6p	only charge collection	
15	9	4	0	50	Ag	15	1634	0	44.90	1.00E+04	1.00E+06	4.00E+06	718	2.874E+03	12n	5p	2 events	

Appendix C

Table C1. Selected Pre- and Post-Irradiation Gate Stress Test Results

Run #:	1	2	3	4	5	6	7	8	9	10	11	12	13	14	15
DUT S/N:	551	551	551	1	1	1	1	8	8	8	8	9	9	9	9
Run Vds (V):	25	50	75	30	40	50	50	30	40	45	50	30	40	45	50
Run Vgs (V):	0	0	0	0	0	0	0	0	0	0	0	0	0	0	0
Ion species:	Ag	Ag	Ag	Ag	Ag	Ag	Ag	Ag	Ag	Ag	Ag	Ag	Ag	Ag	Ag
Vgs (V)	Ig (A)														
0	3.48E-11	4.80E-11	Compliance Reached	4.54E-11	4.57E-11	4.99E-11	Compliance Reached	5.46E-11	5.18E-11	5.21E-11	5.65E-11	4.47E-11	4.54E-11	4.87E-11	Compliance Reached
2	-7.41E-11	-5.20E-10		-7.29E-11	-7.05E-11	-7.23E-09		-7.33E-11	-7.75E-11	-7.55E-11	-1.52E-08	-7.60E-11	-7.99E-11	-7.57E-11	
4	-3.40E-11	-6.87E-09		-3.25E-11	-3.45E-11	-7.32E-08		-3.41E-11	-3.54E-11	-3.44E-11	-1.17E-07	-3.17E-11	-3.32E-11	-3.19E-11	
6	-4.46E-11	-4.01E-08		-4.54E-11	-4.67E-11	-2.63E-07		-4.64E-11	-4.68E-11	-4.72E-11	-3.56E-07	-4.48E-11	-4.46E-11	-4.45E-11	
8	-1.54E-10	-1.39E-07		-1.51E-10	-1.54E-10	-6.53E-07		-1.59E-10	-1.60E-10	-1.59E-10	-8.06E-07	-1.50E-10	-1.52E-10	-1.49E-10	
10	-1.82E-10	-3.81E-07		-1.79E-10	-1.80E-10	-1.51E-06		-1.88E-10	-1.89E-10	-1.87E-10	-1.59E-06	-1.77E-10	-1.79E-10	-1.75E-10	
12	-2.01E-10	-9.49E-07		-1.98E-10	-2.00E-10	-3.09E-06		-2.09E-10	-2.07E-10	-2.08E-10	-3.28E-06	-1.98E-10	-2.00E-10	-1.96E-10	
14	-2.20E-10	-2.09E-06		-2.18E-10	-2.25E-10	-6.28E-06		-2.33E-10	-2.30E-10	-2.30E-10	-6.37E-06	-2.30E-10	-2.27E-10	-2.22E-10	
16	-2.58E-10	-4.29E-06		-2.54E-10	-2.63E-10	-1.08E-05		-2.77E-10	-2.73E-10	-2.70E-10	-1.22E-05	-2.96E-10	-2.77E-10	-2.66E-10	
18	-2.79E-10	-7.95E-06		-2.72E-10	-2.83E-10	-4.72E-03		-3.03E-10	-2.96E-10	-2.93E-10	-4.93E-03	-3.28E-10	-3.10E-10	-2.91E-10	
20	-2.94E-10	-3.44E-03		-2.89E-10	-2.99E-10	-5.77E-03		-3.25E-10	-3.18E-10	-3.14E-10	-5.20E-03	-3.55E-10	-3.38E-10	-3.21E-10	
0	2.60E-10	3.38E-08		2.42E-10	2.47E-10	2.58E-08		3.00E-10	2.84E-10	2.86E-10	5.50E-08	2.48E-10	2.52E-10	2.47E-10	
2	1.72E-10	8.61E-05		1.61E-10	1.66E-10	1.08E-04		1.93E-10	1.85E-10	1.86E-10	1.19E-04	1.74E-10	1.78E-10	1.74E-10	
4	1.47E-10	4.69E-04		1.40E-10	1.43E-10	6.91E-04		1.80E-10	1.55E-10	1.76E-10	8.16E-04	1.52E-10	1.52E-10	1.49E-10	
6	1.71E-10	3.67E-03		1.57E-10	1.61E-10	3.89E-03		1.79E-10	1.71E-10	1.76E-10	4.45E-03	1.74E-10	1.69E-10	1.67E-10	
8	1.87E-10	5.77E-03		1.75E-10	1.71E-10	6.54E-03		1.89E-10	1.82E-10	1.83E-10	7.23E-03	1.91E-10	1.81E-10	1.75E-10	
10	2.04E-10	8.34E-03		1.91E-10	1.86E-10	9.61E-03		2.03E-10	1.94E-10	1.94E-10	1.02E-02	2.08E-10	1.91E-10	1.86E-10	
12	2.21E-10	1.17E-02		2.10E-10	1.99E-10	1.32E-02		2.20E-10	2.07E-10	2.08E-10	1.35E-02	2.29E-10	2.03E-10	1.96E-10	
14	2.39E-10	1.51E-02		2.26E-10	2.12E-10	1.72E-02		2.36E-10	2.22E-10	2.20E-10	1.72E-02	2.52E-10	2.16E-10	2.07E-10	
16	2.41E-10	1.84E-02		2.44E-10	2.26E-10	2.15E-02		2.21E-10	2.36E-10	2.33E-10	2.12E-02	2.71E-10	2.30E-10	2.18E-10	
18	2.68E-10	2.18E-02	2.51E-10	2.32E-10	2.54E-02	2.23E-10	2.40E-10	2.36E-10	2.48E-02	2.79E-10	2.38E-10	1.74E-10			
20	2.79E-10	2.51E-02	2.73E-10	2.58E-10	2.94E-02	2.76E-10	2.65E-10	2.60E-10	2.92E-02	3.07E-10	2.71E-10	2.43E-10			
Idss (uA):	-2.09E-08	-2.65E-07		-1.87E-08	-1.91E-08	-9.23E-07		-1.69E-08	-1.80E-08	-1.98E-08	-7.49E-07	-1.89E-08	-2.07E-08	-2.22E-08	

Appendix D

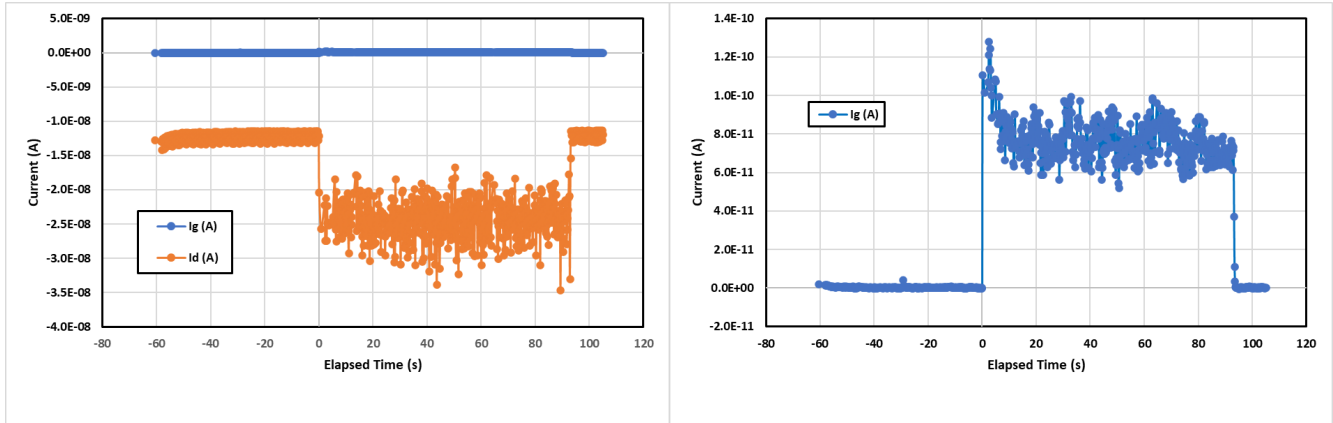

Figure D1. Strip tape data from DUT 0551, run 1: 1634 MeV Ag. Run bias conditions: 0 V_{GS}, -25 V_{DS}. Total Fluence of 1×10^6 at a flux of about 1×10^4 for 100s. Left: charge collection can be seen in drain current trace. Right: board capacitive current present pre-beam (time < 0 s) and into the beam run. As with drain current, gate current reflects charge collection as evidenced by current reduction after beam off.

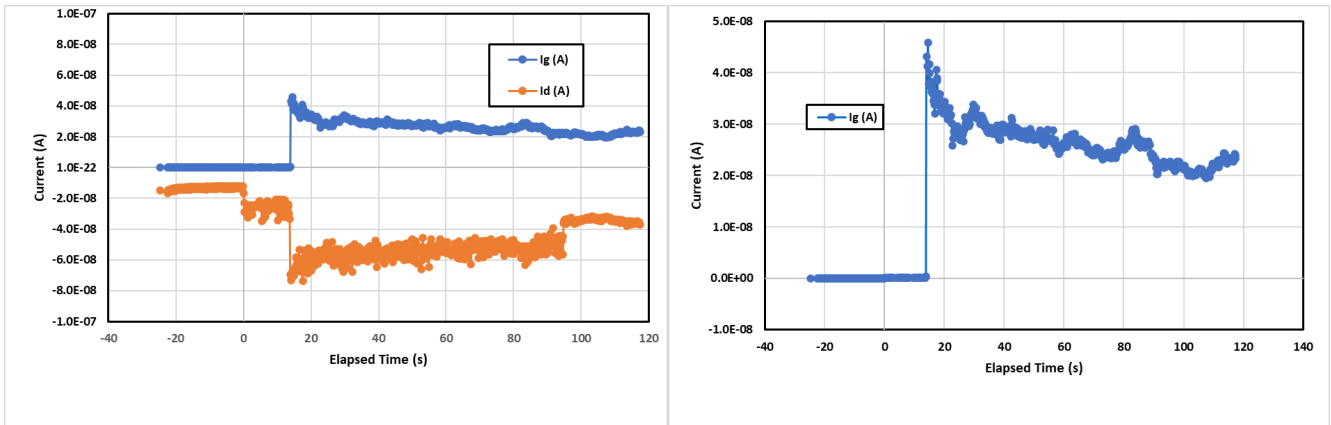

Figure D2. Strip tape data from DUT 0551, run 2: 1634 MeV Ag. Run bias conditions: 0 V_{GS}, -50 V_{DS}. Total Fluence of 1×10^6 at a flux of about 1×10^4 for 100s. Left: charge collection can be seen in drain current trace between 0 and ~15s. A large current increase around 15s of irradiation time is indicative of device damage. Right: Isolation of gate current shows single event around 15s of exposure resulting in tens of nanoamps of leakage current. Device completely failed in post irradiation stress tests.

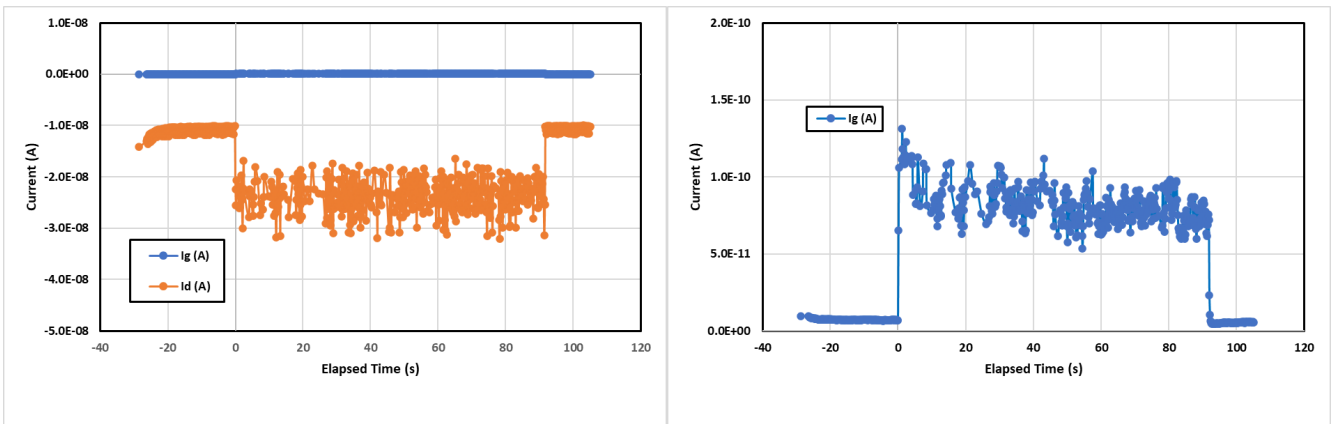

Figure D3. Strip tape data from DUT 0001, run 5: 1634 MeV Ag. Run bias conditions: 0 V_{GS}, -40 V_{DS}. Total Fluence of 1×10^6 at a flux of about 1×10^4 for 100s.

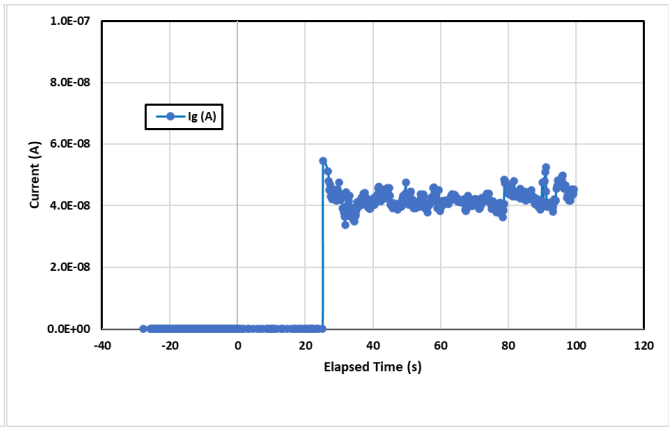
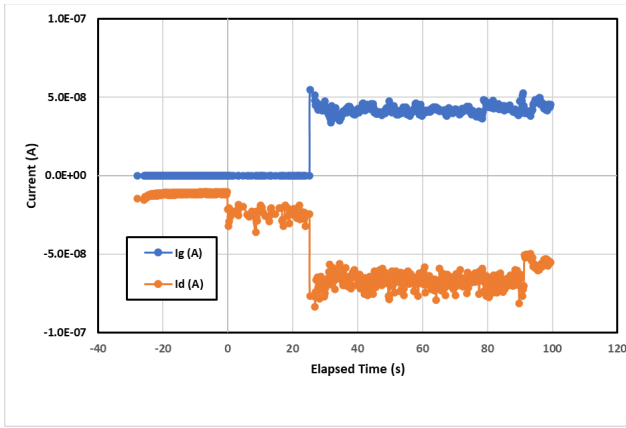

Figure D4. Strip tape data from DUT 0001, run 6: 1634 MeV Ag. Run bias conditions: 0 V_{GS}, -50 V_{DS}. Total Fluence of 1x10⁶ at a flux of about 1x10⁴ for 100s.

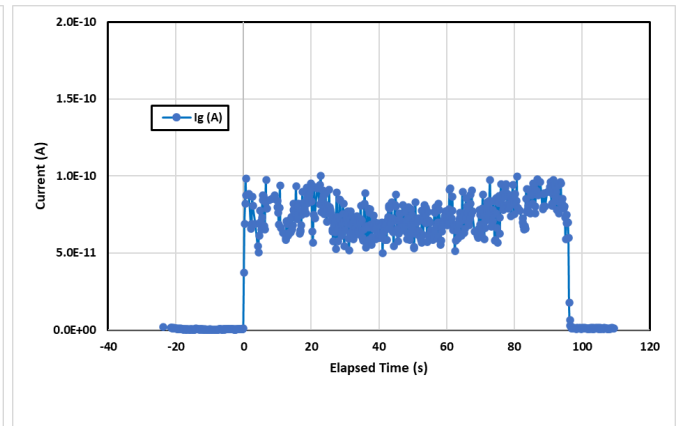
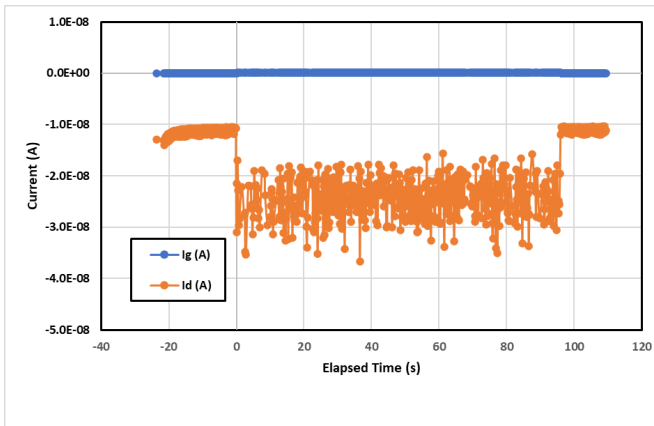

Figure D5. Strip tape data from DUT 0008, run 10: 1634 MeV Ag. Run bias conditions: 0 V_{GS}, -45 V_{DS}. Total Fluence of 1x10⁶ at a flux of about 1x10⁴ for 100s.

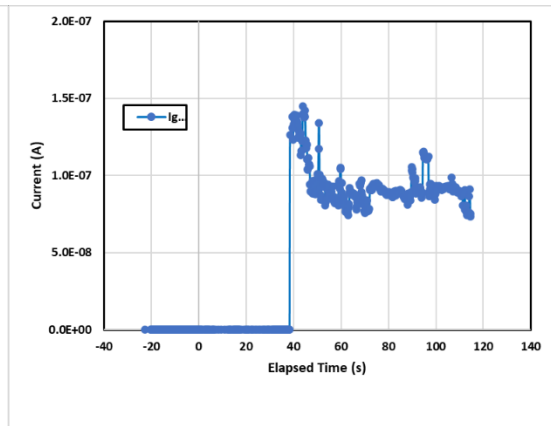
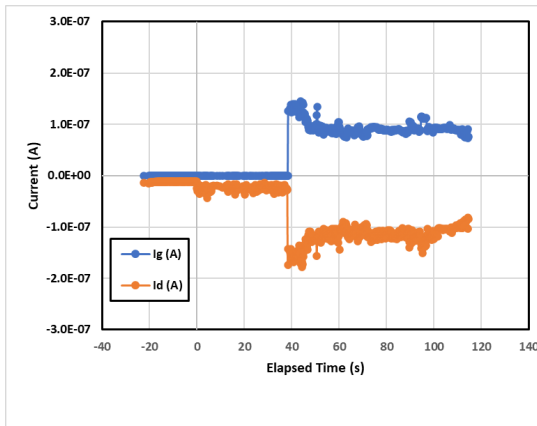

Figure D6. Strip tape data from DUT 0008, run 11: 1634 MeV Ag. Run bias conditions: 0 V_{GS}, -50 V_{DS}. Total Fluence of 1x10⁶ at a flux of about 1x10⁴ for 100s.

