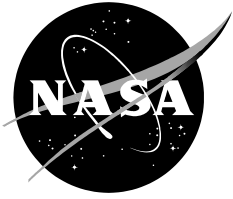


NASA/TP—20220018058



# **State-of-the-Art Small Spacecraft Technology**

*Small Spacecraft Systems Virtual Institute*

*Ames Research Center, Moffett Field, California*

---

**January 2023**

## NASA STI Program ... in Profile

Since its founding, NASA has been dedicated to the advancement of aeronautics and space science. The NASA scientific and technical information (STI) program plays a key part in helping NASA maintain this important role.

The NASA STI program operates under the auspices of the Agency Chief Information Officer. It collects, organizes, provides for archiving, and disseminates NASA's STI. The NASA STI program provides access to the NASA Aeronautics and Space Database and its public interface, the NASA Technical Reports Server, thus providing one of the largest collections of aeronautical and space science STI in the world. Results are published in both non-NASA channels and by NASA in the NASA STI Report Series, which includes the following report types:

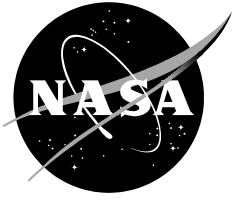
- TECHNICAL PUBLICATION. Reports of completed research or a major significant phase of research that present the results of NASA Programs and include extensive data or theoretical analysis. Includes compilations of significant scientific and technical data and information deemed to be of continuing reference value. NASA counterpart of peer-reviewed formal professional papers but has less stringent limitations on manuscript length and extent of graphic presentations.
- TECHNICAL MEMORANDUM. Scientific and technical findings that are preliminary or of specialized interest, e.g., quick release reports, working papers, and bibliographies that contain minimal annotation. Does not contain extensive analysis.
- CONTRACTOR REPORT. Scientific and technical findings by NASA-sponsored contractors and grantees.
- CONFERENCE PUBLICATION. Collected papers from scientific and technical conferences, symposia, seminars, or other meetings sponsored or co-sponsored by NASA.
- SPECIAL PUBLICATION. Scientific, technical, or historical information from NASA programs, projects, and missions, often concerned with subjects having substantial public interest.
- TECHNICAL TRANSLATION. English-language translations of foreign scientific and technical material pertinent to NASA's mission.

Specialized services also include organizing and publishing research results, distributing specialized research announcements and feeds, providing information desk and personal search support, and enabling data exchange services.

For more information about the NASA STI program, see the following:

- Access the NASA STI program home page at <http://www.sti.nasa.gov>
- E-mail your question to [help@sti.nasa.gov](mailto:help@sti.nasa.gov)
- Fax your question to the NASA STI Information Desk at 443-757-5803
- Phone the NASA STI Information Desk at 443-757-5802
- Write to:  
STI Information Desk  
NASA Center for Aerospace Information  
7115 Standard Drive  
Hanover, MD 21076-1320

NASA/TP—20220018058



# **State-of-the-Art Small Spacecraft Technology**

*Small Spacecraft Systems Virtual Institute*

*Ames Research Center, Moffett Field, California*

National Aeronautics and  
Space Administration

*Ames Research Center  
Moffett Field, CA 94035-1000*

---

**January 2023**

The use of trademarks or names of manufacturers in this report is for accurate reporting and does not constitute an official endorsement, either expressed or implied, of such products or manufacturers by the National Aeronautics and Space Administration.

Available from:

NASA Center for AeroSpace Information  
7115 Standard Drive  
Hanover, MD 21076-1320  
443-757-5802

This report is also available in electronic form at  
<http://www.nasa.gov/smallsat-institute/sst-soa>

**NASA STI Support Services**  
Mail Stop 148  
NASA Langley Research Center  
Hampton, VA 23681-2199  
757-864-9658

**National Technical Information Service**  
5301 Shawnee Rd.  
Alexandria, VA 22312  
[webmail@ntis.gov](mailto:webmail@ntis.gov)  
703-605-6000



**SMALL SPACECRAFT SYSTEMS VIRTUAL INSTITUTE**  
Small Spacecraft Technology  
State of the Art Report



## 2022 SOA Cover Page Image Credits

### **First from the top**

Spacecraft: Artist's (M. Combs and B. Malphrus) concept of Lunar IceCube in lunar orbit. Credit: Morehead State University

Profile Technology: Space Micro P400. Credit: Space Micro, Inc.

### **Second from the top**

Spacecraft: The LunaH-Map spacecraft's destination is an orbit around the Moon.

Credit: Arizona State University

Profile Technology: MMA eHAWK solar arrays. Credit: MMA Design, LLC

### **Third from the top**

Spacecraft: Illustration of Lunar Flashlight at the Moon. Credits: NASA / JPL-CalTech

Profile Technology: Lunar Flashlight's propulsion system. Credits: NASA / Georgia Institute of Technology

### **Fourth from the top**

Spacecraft: Pathfinder Demonstrator Technology-3. Credit: NASA

Profile Technology: TeraByte InfraRed Delivery (TBIRD). Credit: Massachusetts Institute of Technology, Lincoln Laboratory

### **Fifth from the top**

Spacecraft: GPX-2 mission. Credit: NASA

Profile Technology: Redwire Space deployable boom. Credit: NASA

### **Sixth from the top**

Spacecraft: Scintillation Prediction Observations Research Task (SPORT) mission.

Credits: NASA / Virgin Orbit National Systems

Profile Technology: GPS Radio Occultation (Compact Total Electron Content Sensor).

Credit: The Aerospace Corporation

NASA Ames Research Center, Small Spacecraft Systems Virtual Institute

*January 2023*

**Small Spacecraft Systems Virtual Institute Director:**

Bruce Yost

**Editor:**

Sasha Weston

**Contributors and Reviewers:**

Helpful suggestions and contributions were also received from numerous people across NASA. In particular, the following are acknowledged for their participation as contributors or reviewers on the 2022 SOA report:

From NASA Ames Research Center: Craig Burkhard, Winston Czakon, Andres Dono, Julianna Fishman, Rodolphe De Rosee, David Mayer, Marc Murbach and the TechEdSat team, Anh Nguyen, Philip Shih, Jan Stupl, Ramkumar Subbaraman, Rachel Ticknor, Shang Wu, and Senior Technical Editor Teague Soderman

From NASA Glenn Research Center: Marc Abadie, Gabriel Benavides, Valenzuela Brok, Thomas Liu, Steven Schneider, and Hunter Williams

From NASA Goddard Spaceflight Center and Wallops Flight Facility: Bernie Edwards, Matthew Hejduk, Dolan Highsmith, John Hudeck, Scott Hull, Alinda Mashiku, Eliad Peretz, Juan Rodriguez-Ruiz, Luis Santos Soto, and Marta Shelton

From NASA Johnson Space Center: James Berck, Eric Christiansen, Jer-Chyi Liou, Mrugen Patel, and Samuel Pedrotty

From NASA Kennedy Space Center: Liam Cheney, Shaun Daly, Donna Freeland, Norman Phelps, and Brad Poffenberger

From NASA Langley Research Center: William Fabanich, Jin Ho Kang, and Laurence Thomsen

From NASA Headquarters: Alicia Mendoza-Hill and Lauri Newman

From NASA Jet Propulsion Laboratory: Peter Kahn, Christian Liebe, and Kevin Lo

From United States Space Force, 18th Space Defense Squadron: Diana McKissock and Cynthia Wilson

From Massachusetts Institute of Technology: Kerri Cahoy, Dansil Green, William Kammerer, and Miles Lifson

The authors would like to also thank all of the companies, universities and organizations who provided information for this report.



## Preface

When the first edition of NASA's *Small Spacecraft Technology State-of-the-art* report was published in 2013, 247 CubeSats and 105 other non-CubeSat small spacecraft under 50 kilograms (kg) had been launched worldwide, representing less than 2% of launched mass into orbit over multiple years. In 2013 alone, around 60% of the total spacecraft launched had a mass under 600 kg, and of those under 600 kg, 83% were under 200 kg and 37% were nanosatellites (1). Of the total 1,849 spacecraft launched in 2021, 94% were small spacecraft with an overall mass under 600 kg, and of those under 600 kg, 40% were under 200 kg, and 11% were nanosatellites (1). Since 2013, the flight heritage for small spacecraft has increased by over 30% and has become the primary source to space access for commercial, government, private, and academic institutions. The total number of spacecraft launched in the past 10 years is 5,681 and 45% of those had a mass <200 kg (1).

As with all previous editions of this report, the 2022 edition captures and distills a wealth of new information available on small spacecraft systems from NASA and other publicly available sources. This report is limited to publicly available information and cannot reflect major advances in development that are not publicly disclosed. We encourage any opportunity to publish mission outcomes and technology development milestones (e.g., via conference papers, press releases, company website) so they can be reflected in this report. Overall, this report is a survey of small spacecraft technologies sourced from open literature; it does not endeavor to be an original source, and only considers literature in the public domain to identify and classify devices. Commonly used sources for data include manufacturer datasheets, press releases, conference papers, journal papers, public filings with government agencies, news articles, presentations, the compendium of databases accessed via NASA's Small Spacecraft Systems Virtual Institute (S3VI) Information Search, and engagement with companies. Data not appropriate for public dissemination, such as proprietary, export controlled, or otherwise restricted data, are not considered. As a result, this report includes many dedicated hours of desk research performed by subject matter experts reviewing resources noted above. Content in this 2022 edition is based on data available by October 2022. This report should not be considered as a comprehensive overview of all the technologies but a great reference for the current state-of-the-art SmallSat technologies.

The organizational approach for each chapter is relatively consistent with previous editions and includes an introduction of the technology, current development status of the technology's procurable systems, and summary tables of technologies surveyed. The content in each chapter is uniquely organized to present a mini-stand-alone report on spacecraft subsystems. As in previous years, chapters include information from previous editions but are updated with new and maturing technologies and reference missions. Tables in each section provide a convenient summary of the technologies discussed, with explanations and references in the body text. The authors have attempted to isolate trends in the small spacecraft industry to point out which technologies have been adopted after successful demonstration missions. Lastly, the authors tried to use the terms "SmallSat," "microsatellite," "nanosatellite," and "CubeSat" in a consistent manner, even as these terms are often used interchangeably in the space industry.

Every subsystem chapter contains updated information to reflect the growth in the small spacecraft market. Significant changes are included in several chapters. The "Complete Spacecraft Platforms" chapter now includes information on the two main market options, hosted payload services and dedicated buses. The "Power" chapter provides information on the development of solid-state batteries with significantly higher energy than the current state-of-the-art lithium-ion batteries. A large effort was made to update the "Communications" chapter to appropriately capture the recent technology maturation of optical communications for SmallSats. The "Ground Data Systems and Mission Operations" chapter was updated to reflect the recent





establishment of the Near Space Network and influx of SmallSat Optical Ground Stations. The “Guidance, Navigation and Control” chapter was updated to include Lidar sensor technology. The “Deorbit Systems” chapter includes a discussion of recently proposed changes by the Federal Communications Commission (FCC) to limit a spacecraft’s lifetime to no longer than 5 years after end-of-mission. The “Identification and Tracking” Chapter includes updated information on the progress of SmallSat tracking. Finally, this report now encompasses technology funded by NASA’s Small Spacecraft Technology (SST) program’s SmallSat Technology Partnerships (STP) initiative which is described further in this Introduction. The reader can find the included SST technology in the “On the Horizon” section of the “Thermal Systems”, “Communications”, and “Guidance, Navigation, and Control” chapters.

A central element of this report is to list state-of-the-art technologies by NASA standard Technology Readiness Level (TRL) as defined by the 2020 NASA Engineering Handbook, found in NASA NPR 7123.1C *NASA Systems Engineering Processes and Requirements*. The authors have endeavored to independently verify the TRL value of each technology by reviewing and citing published test results or publicly available data to the best of their ability. Where test results and data disagree with vendors’ own advertised TRL, the authors have attempted to engage the vendors to discuss the discrepancy. Readers are strongly encouraged to follow the references cited in the literature describing the full performance range and capabilities of each technology. Readers of this report should reach out to individual companies to further clarify information. It is important to note that this report takes a broad system-level view. To attain a high TRL, the subsystem must be in a flight-ready configuration with all supporting infrastructure—such as mounting points, power conversion, and control algorithms—in an integrated unit.

An accurate TRL assessment requires a high degree of technical knowledge on a subject device, and an in-depth understanding of the mission (including interfaces and environment) on which the device was flown. There is variability in TRL values depending on design factors for a specific technology. For example, differences in TRL assessment based on the operating environment may result from the thermal environment, mechanical loads, mission duration, or radiation exposure. If a technology has flown on a mission without success, or without providing valid confirmation to the operator, such claimed “flight heritage” was discounted. The authors believe TRLs are most accurately determined when assessed within the context of a program’s unique requirements.

While the overall capability of small spacecraft has matured since the 2021 edition of this report, technologies are still being developed to make deep space SmallSat missions more routine and more cost effective.

Future editions of this report may include content dedicated to the rapidly growing fields of assembly, integration, and testing services, and mission modeling and simulation—all of which are now extensively represented at small spacecraft conferences. Many of these subsystems and services are still in their infancy, but as they evolve and reliable conventions and standards emerge, the next iteration of this report may also evolve to include additional chapters.

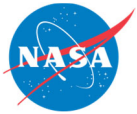
## References

- (1) Bryce and Space Technology. “SmallSat by the Numbers, 2022.” [Online] Accessed: September 28, 2022. [https://brycetech.com/reports/report-documents/Bryce\\_SmallSats\\_2022.pdf](https://brycetech.com/reports/report-documents/Bryce_SmallSats_2022.pdf)



## Chapter Glossary

(EELV)	Evolved Expendable Launch Vehicle
(ESPA)	EELV Secondary Payload Adapter
(FASTSAT)	Fast, Affordable, Science and Technology Satellite
(LADEE)	Lunar Atmosphere and Dust Environment Explorer
(LCROSS)	Lunar Crater Observation and Sensing Satellite
(NODIS)	NASA Online Directives Information System
(SST)	Small Spacecraft Technology
(STMD)	Space Technology Mission Directorate
(TMA)	Technology Maturity Assessment
(TRL)	Technology Readiness Level
(U)	Unit



## 1.0 Introduction

### 1.1 Objective

The objective of this report is to assess and provide an overview of the state of the art in small spacecraft technologies for mission designers, project managers, technologists, and students. This report focuses on the spacecraft system in its entirety, provides current best practices for integration, and then presents the state of the art for each specific spacecraft subsystem. Certain chapters have a particular emphasis on CubeSat platforms, as nanosatellite applications have expanded due to their high market growth in recent years.

This report is funded by NASA's Space Technology Mission Directorate (STMD) and Science Mission Directorate (SMD). It was first commissioned by the Small Spacecraft Technology (SST) program within NASA's STMD in mid-2013 in response to the rapid growth in interest in using small spacecraft for low-Earth orbit, low-cost missions. The report was subsequently updated in 2015, 2018, 2020, and 2021. In addition to reporting currently available state-of-the-art technologies that have achieved TRL 5 or above, a prognosis is provided describing technologies as "on the horizon" if they are being considered for future application. A recent inclusion to this latest 2022 edition is the addition of technologies being developed within the SST program's SmallSat Technology Partnerships (STP) initiative. These technologies will be presented in the "On the Horizon" section in their respective subsystem chapter.

### 1.2 Scope

The SmallSat mission timeline began at NASA Ames Research Center with the launch of Pioneer 10 and 11 that launched in March 1972 and April 1973, respectively, where both spacecraft weighed < 600 kg. To address the increase in mass and associated cost with the high launch cadence, NASA initiated the Small Explorer (SMEX) program in 1988 to encourage the development of small spacecraft with masses in the range of ~60–350 kg. In 1998, Ames' SmallSat program then focused on lunar exploration and launched Lunar Prospector (< 700 kg), followed by the Lunar Crater Observation and Sensing Satellite (LCROSS), (< 630 kg) in 2009, and the Lunar Atmosphere and Dust Environment Explorer (LADEE), (~380 kg) which was launched in September 2013. In late 2010, NASA launched its first minisatellite called Fast, Affordable, Science and Technology Satellite (FASTSAT), which had a launch mass ~180 kg. This decrease in spacecraft mass, reduced overall cost, and increase in science capabilities ignited interest in miniaturization and maturity of aerospace technologies which have proven to be capable of producing more complex missions for less cost.

The Evolved Expendable Launch Vehicle (EELV) Secondary Payload Adapter (ESPA) payloads provided up to 180 kg mass allocation to six payload slots in 2012 when this report was first being written. As this report is focused on smaller platforms, the "180 kg mass limit" served as a good indicator to further classify the maximum "SmallSat" mass. SmallSats are generally grouped according to their mass, and this report adopts the following five small spacecraft mass categories (1):

- minisatellites are spacecraft with a total mass of 100 – 180 kg;
- microsatellites have a total spacecraft mass of 10 – 100 kg;
- nanosatellites have a total mass of 1 – 10 kg;
- picosatellites have a mass of 0.1 – 1 kg; and
- femtosatellites have a total spacecraft mass 0.001 – 0.1 kg.

Figure 1.1 offers examples of the various categorized spacecraft. On the lower mass end are femtosatellites that tend to be organization-dependent on their upper mass limits; several

institutions generally regard a femtosatellite as <100 grams. KickSat-2 deployed 100-centimeter (cm) scale “ChipSat” spacecraft, or Sprites, from a 2U femtosatellite deployer in March 2019. ChipSats are the size of a large postage stamp and have a mass around 5 grams.

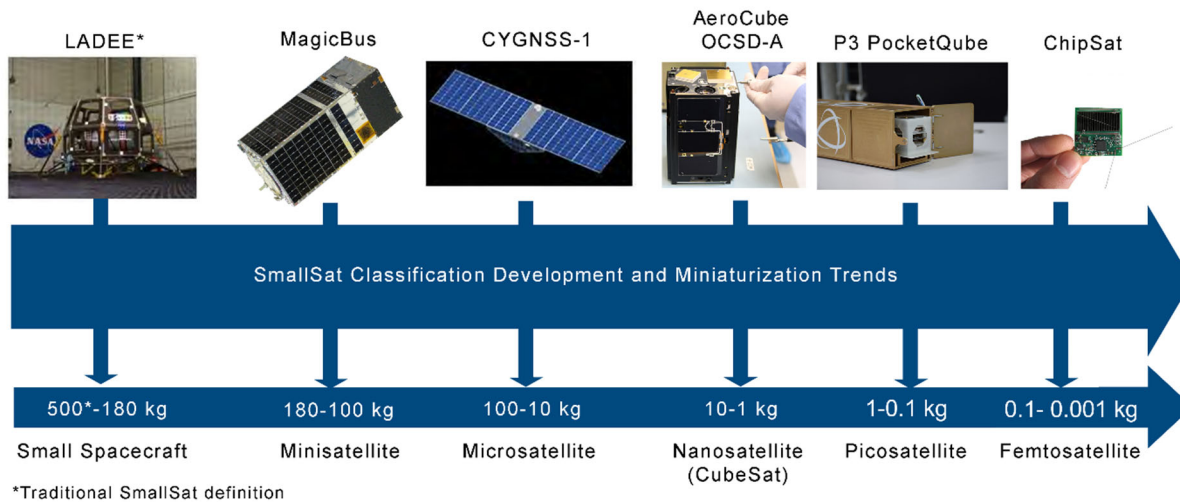


Figure 1.1: Overview of small spacecraft categories. Credit: NASA, SpaceX, Redwire Space, and Alba Orbital.

In 1999, a collaboration between California Polytechnic State University (Cal Poly) in San Luis Obispo and Stanford University in Stanford, California, developed a small educational platform called a "CubeSat" which was designed for space exploration and research for academic purposes. CubeSats are now a common form of small spacecraft that can weigh only a few kilograms and are based on a form factor of a 10 cm square cube, or unit (U) (1). The original CubeSat was composed of a single cube, a 1U, and it is now common to combine multiple cubes to form, for instance, 3U or 6U units as shown in figure 1.2. These larger CubeSat sizes have become more standardized and popular in the past five years as much more science can be achieved at less cost with the additional volume, power, and overall increase in capability.

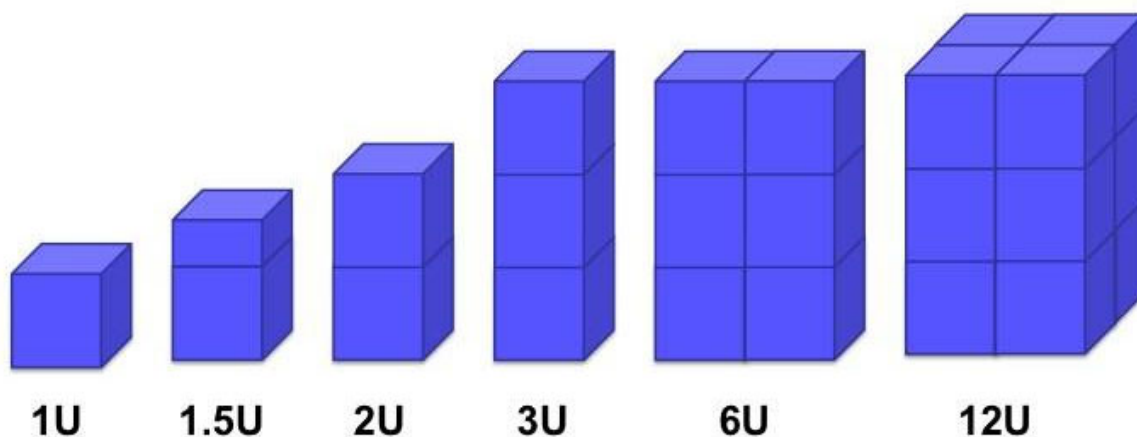
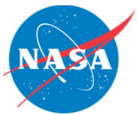


Figure 1.2: CubeSats are a class of nano- and microsatellites that use a standard size and form factor. Credit: NASA.



It is common to interchange the terms “CubeSat” and “NanoSat” (short for nanosatellite) as the original 1-3U CubeSat platforms fall under the nanosatellite category. Since the physical expansion of CubeSats in 2014 with the 6U form factor, CubeSats now fall into both nanosatellite and microsatellite categories, and this report refers to a nanosatellite as a spacecraft with mass under 10 kg; a microsatellite as a spacecraft with mass greater than 10 kg; and a CubeSat as the accepted form factor. Figure 1.3 illustrates the three smaller SmallSat categories: microsatellites, nanosatellites, and picosatellites.

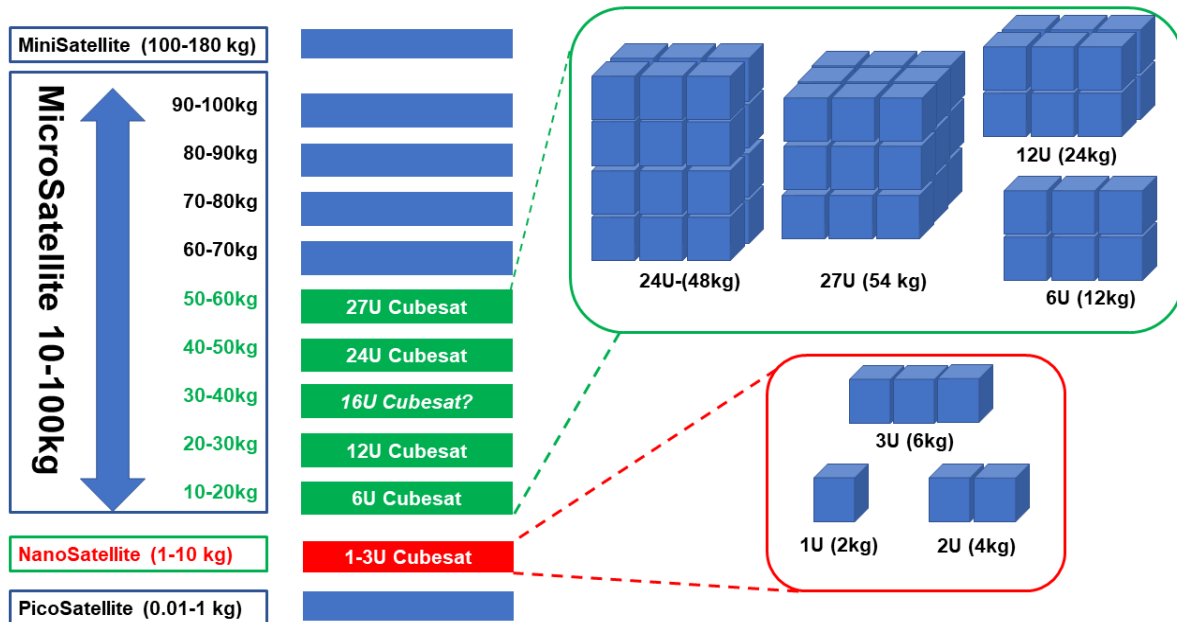


Figure 1.3: Nanosatellite sizes compared to CubeSat containerized sizes. Credit: NASA.

### 1.3 Assessment

This state-of-the-art assessment of SmallSat technology is performed using NASA’s Technology Readiness Level (TRL) scale (figure 1.4). For this report, a technology is deemed state-of-the-art whenever its TRL is higher than or equal to 5. A TRL of 5 indicates that the component and/or brassboard with realistic support elements was built and operated for validation in a relevant environment so as to demonstrate overall performance in critical areas. Success criteria include documented test performance demonstrating agreement with analytical predictions and documented definition of scaling requirements. Performance predictions are made for subsequent development phases (2).

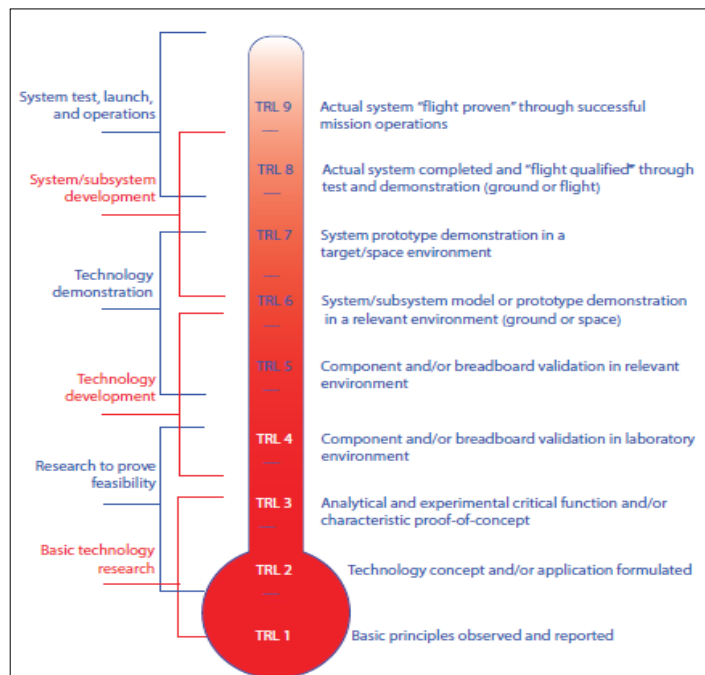


Figure 1.4: NASA’s standard TRL scale. Credit: NASA.



A technology is considered not state of the art whenever its TRL is lower than or equal to 4. In this category, the technology is considered to be “on the horizon.” A TRL of 4 is defined as a component and/or breadboard validated in a laboratory environment with documented test performance demonstrating agreement with analytical predictions and a documented definition of the relevant environment.

NASA standard TRL requirements for this report edition are stated in the NPR 7123.1C, Appendix E, which is effective through February 14, 2025. The criteria for selection of appropriate TRL are described in the NASA Systems Engineering Handbook 6105 Rev 2 Appendix G: Technology Assessment/Insertion. Please refer to the NASA Online Directives Information System (NODIS) website

<https://nodis3.gsfc.nasa.gov/> for NPR documentation. The following paragraphs in sections 1.3.1 and 1.3.2 of this introduction are excerpts from the NASA Engineering Handbook 6105 Rev 2 (pp. 252 – 254). They highlight important aspects of NASA TRL guidelines in hopes of eliminating confusion on terminology and heritage systems.

### 1.3.1 Terminology

“At first glance, the TRL descriptions in figure 1.4 appear to be straightforward. It is in the process of trying to assign levels that problems arise. A primary cause of difficulty is in terminology, e.g., everyone knows what a breadboard is, but not everyone has the same definition. Also, what is a “relevant environment?” What is relevant to one application may or may not be relevant to another. Many of these terms originated in various branches of engineering and had, at the time, very specific meanings to that particular field. They have since become commonly used throughout the engineering field and often acquire differences in meaning from discipline to discipline, some differences subtle, some not so subtle. “Breadboard,” for example, comes from electrical engineering where the original use referred to checking out the functional design of an electrical circuit by populating a “breadboard” with components to verify that the design operated as anticipated. Other terms come from mechanical engineering, referring primarily to units that are subjected to different

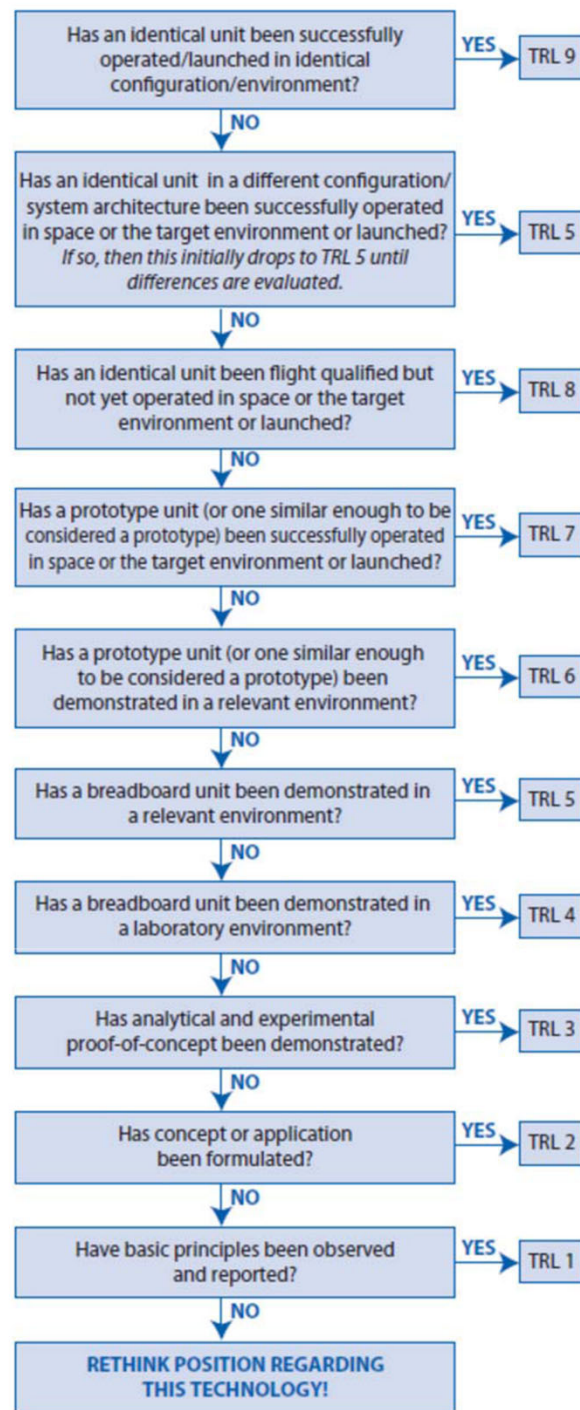


Figure 1.5: Technology Maturity Assessment (TMA) thought process. Credit: NASA.



levels of stress under testing, e.g., qualification, protoflight, and flight units. The first step in developing a uniform TRL assessment (see figure 1.5) is to define the terms used. It is extremely important to develop and use a consistent set of definitions over the course of the program/project.”

### **1.3.2 Heritage Systems**

“Note the second box particularly refers to heritage systems (figure 1.5). If the architecture and the environment have changed, then the TRL decreases to TRL 5—at least initially. Additional testing may need to be done for heritage systems for the new use or new environment. If in subsequent analysis the new environment is sufficiently close to the old environment or the new architecture is sufficiently close to the old architecture, then the resulting evaluation could be TRL 6 or 7, but the most important thing to realize is that it is no longer at TRL 9. Applying this process at the system level and then proceeding to lower levels of subsystems and components identifies those elements that require development and sets the stage for the subsequent phase, determining the new TRL.”

### **References**

- (1) NASA. What are SmallSats and CubeSats? February 26, 2015. Revised August 6, 2017. <https://www.nasa.gov/content/what-are-smallsats-and-cubesats>
- (2) NASA Systems Engineering Handbook. NASA/SP-2016 6105 Rev. 2. <https://www.nasa.gov/feature/release-of-revision-to-the-nasa-systems-engineering-handbook-sp-2016-6105-rev-2>



## Chapter Contents

Chapter Glossary .....	ii
2.0 Complete Spacecraft Platforms .....	6
2.1 Introduction .....	6
2.2 State-of-the-Art – Spacecraft Platforms .....	7
2.2.1 Hosted Payloads .....	7
2.2.2 Dedicated Spacecraft Bus .....	9
2.3 Programmatic and Systems Engineering Considerations .....	22
2.4 On the Horizon .....	22
2.5 Summary .....	23
2.6 References .....	23





## Chapter Glossary

(COTS)	Commercial-off-the-Shelf
(EELV)	Evolved Expendable Launch Vehicle
(ESPA)	EELV Secondary Payload Adapter
(GEO)	Geostationary Equatorial Orbit
(I&T)	Integration and Test
(kg)	Kilogram
(LEO)	Low Earth Orbit
(MEO)	Medium Earth Orbit
(MTBF)	Mean Time Between Failures
(NASA)	National Aeronautics and Space Administration
(SHF)	Super High Frequency
(SmallSat)	Small Satellite
(SPA)	Secondary Payload Adapter
(STMD)	Space Technology Mission Directorate
(UHF)	Ultra High Frequency
(UK)	United Kingdom
(Unk)	Unknown
(USA)	United States of America
(VLEO)	Very Low Earth Orbit
(VHF)	Very High Frequency
(W)	Watts



## 2.0 Complete Spacecraft Platforms

### 2.1 Introduction

For years, the SmallSat market has provided a variety of mission-enabling components. Along with a large variety of new and proven components, companies are now offering entire spacecraft bus solutions. Spacecraft bus refers to the side of the mission flight segment that provides essential services to the payload. This chapter addresses the state of the art in the small spacecraft bus offerings and provides the reader with a programmatic overview for small spacecraft mission development.

There are 2 distinct types of SmallSat market options in terms of complete spacecraft platforms. One option is not superior to the other and selection may depend on the needs of each individual mission.

- **Hosted payloads** – Also known as “satellite-as-a-service,” integrates multiple payloads from different and independent customers into the same platform with some form of resource sharing (cost, autonomy, concept of operations, etc.). Hosted payload configurations and performance vary by provider. Two examples of hosted payloads are:
  - Service provider brokers multiple independent customer payloads into a single spacecraft bus (no primary payload)
  - Service provider intends to launch their own satellite with its own primary goals but have unused resources and allows secondary payloads to be added
- **Dedicated spacecraft bus** – the entirety of the spacecraft bus is at the disposal of a single customer or mission

This chapter organizes the state-of-the-art small spacecraft platforms into these two main categories. The dedicated small spacecraft bus section is further divided by PocketQube, CubeSat, and ESPA-Class offerings. Each subsection contains a summary table with a non-exhaustive list of commercially available small spacecraft platforms.

1. Hosted Payloads (2.2.1)
2. Dedicated Spacecraft Bus (2.2.2)
  - a. PocketQubes (2.2.2.1)
  - b. CubeSats (2.2.2.2)
  - c. ESPA-Class (2.2.2.3)

Following Section 2.2 is a brief explanation on systems engineering considerations that introduces newcomers to the design selection process and highlights specific resources for mission development. On the Horizon is a section that describes upcoming technology considered low maturity and revolutionary in small spacecraft platform with the potential to advance the state-of-the-art.

The list of organizations/companies in this chapter is not all-encompassing and does not constitute an endorsement from NASA. The information is for awareness and guidance only. The performance advertised may differ from actual performance since the information has not been independently verified by the State-of-the-Art document staff and relies on information provided directly from the manufacturers or available public information.

Section 2.6 includes a list of providers with contact information and the source used to complete the tables. It is recommended to contact the organizations/companies directly for further clarification and application to your specific needs.

## 2.2 State-of-the-Art – Spacecraft Platforms

### 2.2.1 Hosted Payloads

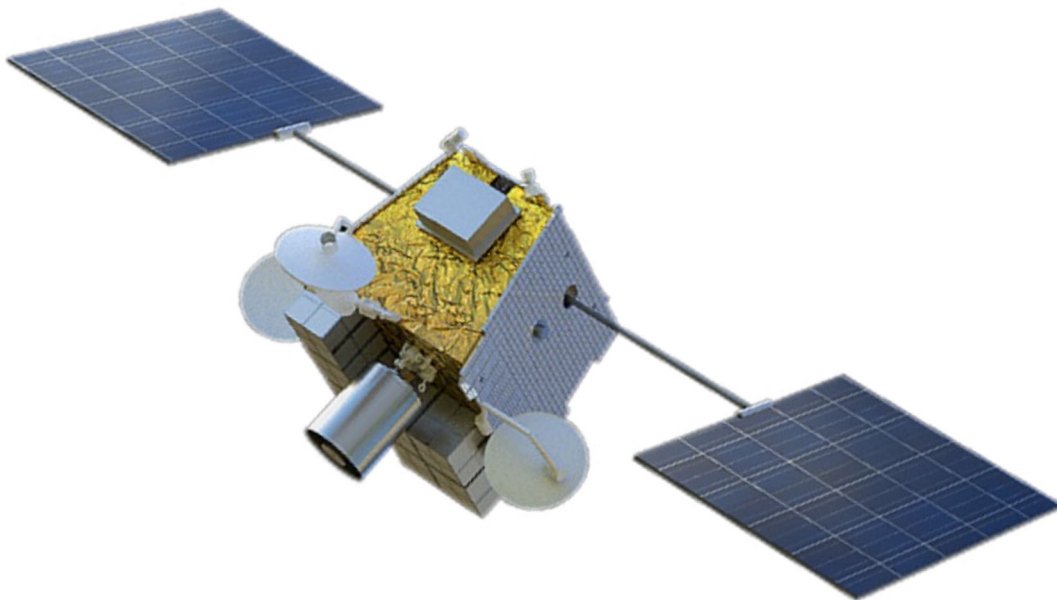
Hosted payloads, also referred as “satellite-as-a-service,” “hitchhiking” or “piggybacking,” is increasing in popularity due to its cost savings. The idea is to share the spacecraft bus platform with other payloads and still achieve mission success. The terms of the agreement are negotiated in advance with the provider to ensure necessary on-orbit time, power, pointing and data volume (among other resources) are adequate for the mission.

Configurations of a hosted payload platform are typically scalable, and several spacecraft platform vendors provide hosted payload services. Larger spacecraft bus hosted options offer deployable capability/mechanisms for smaller nanosatellite missions. NASA's Fast, Affordable, Science and Technology Satellite (FASTSAT) is an example of a minisatellite that hosted smaller science and technology flight missions. It carried several low-TRL experiments and deployed NanoSail-D. See figure 2.1 for an illustration of FASTSAT. Figure 2.2 is from Loft Orbital Hosted Payload Services.

Hosted payload services are becoming more appealing for academic and government scientific missions. This option provides a cost-effective and timely solution to those missions going to the same destination.



*Figure 2.1: Representation of NASA's FASTSAT minisatellite. Credit: NASA.*



*Figure 2.2: A rendering of a generic Longbow-class Loft Orbital satellite. Credit: Loft Orbital.*



Table 2-1: Hosted Payload Providers

Organization	Max Volume	Max Mass (kg)	Peak Power (W)	3- $\sigma$ Pointing Control/ Knowledge	Destination	US Office
Artemis Space Technologies <sup>UK</sup>	0.58m <sup>3</sup>	500	1,500	0.01°/0.01°	LEO, MEO, GEO, Lunar and Deep Space	No
Astranis Space Technologies Corp. <sup>USA</sup>	0.02m <sup>3</sup>	10	300	<0.1°/< 0.09°	GEO	Yes
Berlin Space Technologies <sup>Germany</sup>	1m <sup>3</sup>	200	3,000	<0.017°/< 0.017°	LEO	No
Bradford Space <sup>USA</sup>	0.38m <sup>3</sup>	220	1,500	1.5°/ 0.006°	LEO, GEO, GTO, Cislunar, Lunar, Deep Space	Yes
C3S Electronics Development <sup>Hungary</sup>	16.5U	18.5	155	0.2°/ 0.2°	LEO, MEO	No
EnduroSat <sup>Bulgaria</sup>	10U	20	60	0.1°/ 0.05°	LEO	Yes
German Orbital Systems <sup>Germany</sup>	Unk	Unk	Unk	Unk	Unk	Unk
In-Space Missions <sup>UK</sup>	Unk	Unk	Unk	Unk	LEO	Unk
Loft Orbital <sup>USA</sup>	435U	70	1,100	<0.045°/<0.015°	LEO	Yes
Momentum <sup>US</sup>	1m <sup>3</sup>	220	1,000	5°/ 0.1°	LEO	Yes
NanoAvionics <sup>Lithuania</sup>	0.7m <sup>3</sup>	150	378	0.15°/ 0.03°	LEO	Yes
Northrop Grumman <sup>USA</sup>	0.37m <sup>3</sup>	50	420	<4°/<1°	LEO	Yes
NPC SPACEMIND <sup>Italy</sup>	9U	18	100	Unk	LEO, MEO	No
Open Cosmos <sup>UK</sup>	14U	18	160	0.03°/0.02°	LEO	No
Orbital Astronautics <sup>UK</sup>	0.125m <sup>3</sup>	100	5,000	<0.05°/<0.01°	LEO, MEO	No
SatRev <sup>Poland</sup>	3U	3	25	1°/0.6°	LEO	No
SITAEL <sup>Italy</sup>	0.54m <sup>3</sup>	90	750	0.017°/ 0.010°	LEO	No
Spacemanic <sup>Czech Republic</sup>	12U	18	500	0.1°/ 0.05°	LEO, MEO, GEO, Lunar	No
Spire Global <sup>USA</sup>	3U	6	35	3°/ 3°	LEO	Yes
Xplore <sup>USA</sup>	0.125 m <sup>3</sup>	55	210	0.17°/ 0.018°	VLEO, LEO, Cislunar	Yes
York Space Systems <sup>USA</sup>	-	300	1,500	0.008°/ 0.004°	LEO, GEO, Lunar	Yes

## 2.2.2 Dedicated Spacecraft Bus

The market has grown considerably over the last 5 years with complete spacecraft bus solutions including I&T and operations options. The addition of I&T and operations gives missions flexibility in implementation, allowing the mission to focus on unique or challenging aspects of the project as needed. Mission implementation solutions are shown in table 2-2. A complete vendor solution can allow the mission organization to focus primarily on payload development, however this may not be appropriate for all missions. For example, an organization may decide to perform their own mission operations if the vendor offerings do not meet the requirements for the project.

Option	Product or Service		
	Spacecraft Bus	System-Level Integration and Testing	Operations
1	Vendor	Vendor	Vendor
2	Vendor	Vendor	Mission Organization
3	Vendor	Mission Organization	Mission Organization
4	Mission Organization	Mission Organization	Mission Organization

### 2.2.2.1 PocketQubes

PocketQubes refer to small satellites that conform to a form factor of 5 cm cubes. PocketQubes use a standard deployer and follow a unit nomenclature of P. In this case 1P refers to a single 5 cm cube (see figure 2.3). Consequently, 2P refers to 2 of these single units. A typical PocketQube deployer can deploy up to a 3P satellite but larger deployers may allow additional capability. PocketQube providers have developed spacecraft busses to simplify mission implementation; a list of providers is included in this section; table 2-3 provides available commercial PocketQube products. Figure 2.4 is an example of a Pocketqube deployer at Alba Orbital.

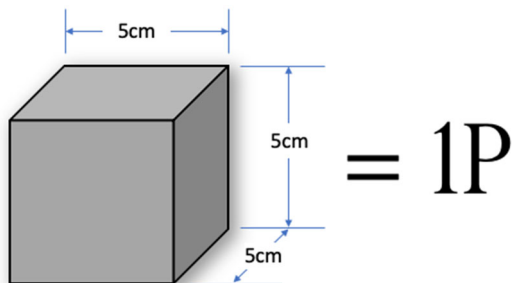


Figure 2.3: PocketQube Dimensions.



Figure 2.4: Alba Orbital Integration of PocketQubes into the Deployers. Credit: Alba Orbital.

Organization	Peak Power (W)	3- $\sigma$ Pointing Control/ Knowledge	Comm Options	Intended Destination	Maturity	US Office
Alba Orbital <sup>UK</sup>	15	5°/2°	UHF, S	LEO	Flown LEO	Yes
Citadel Space Systems <sup>UK</sup>	20	Unk	UHF, S	Unk	Unk	Unk
DIYSATELLITE <sup>Argentina</sup>	9	<5°/<5°	VHF, UHF, SHF	LEO, GEO, Lunar	Flown LEO	No
FOSSA Systems <sup>Spain</sup>	10	<5°/<5°	UHF, S	LEO	Flown LEO	No
Innova Space <sup>Argentina</sup>	Unk	Unk	Unk	Unk	Unk	Unk
Mini-Cubes <sup>USA</sup>	Unk	Unk	Unk	Unk	Unk	Unk

### 2.2.2.1 CubeSats

CubeSats refer to small satellites that conform to a form factor of 10 cm cubes. The CubeSat standard was created by California Polytechnic State University, San Luis Obispo, and Stanford University's Space Systems Development Lab in 1999 to facilitate access to space for university students. When launch providers started adopting this standard as a secondary payload service it enabled increased, low-cost opportunities for space access. Many organizations are currently using the standard including academia, private industry, and government. For more information on the history of CubeSats, the reader is encouraged to review the Introduction of this report.

CubeSat sizes follow a unit nomenclature in which 1 unit or 1U refers to a single 10 cm cube (see figure 2.5). Consequently, 2U refers to 2 of these single units, 3U is a set of 3 single units, and so forth. CubeSat providers have developed spacecraft busses to accommodate missions from 1U to 27U satellites. This section provides a list of providers separated by satellite size: 0.25U-3U, 6U, 12U and 16U+ in tables 2-4, 2-5, 2-6, and 2-7.

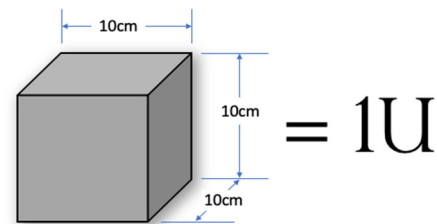


Figure 2.5 - CubeSat Dimensions.

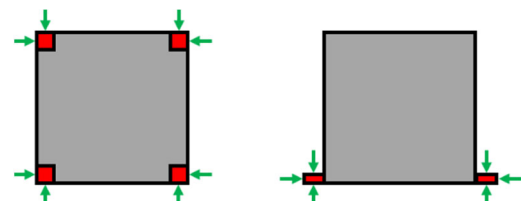


Figure 2.6: Rails vs. Tabs Restraint System Cross-Section.

Multiple companies have developed deployers for CubeSats with different dimensions and external volume allocations. Contact your sponsoring organization and/or launch provider for specifics on which deployer is used in your mission. Many CubeSat deployers exist in the market but the primary 2 interfaces follow the classic corner rails or the tabs (clamped and unclamped), as seen in figure 2.6. Most spacecraft bus providers in this chapter can adapt to different interfaces. Please refer to the Launch, Integration, and Deployment chapter for further information on SmallSat deployers. Figure 2.7 includes images of CubeSat missions that have been successfully flown in space while figure 2.8 provides examples of CubeSat deployers' location on a rocket.

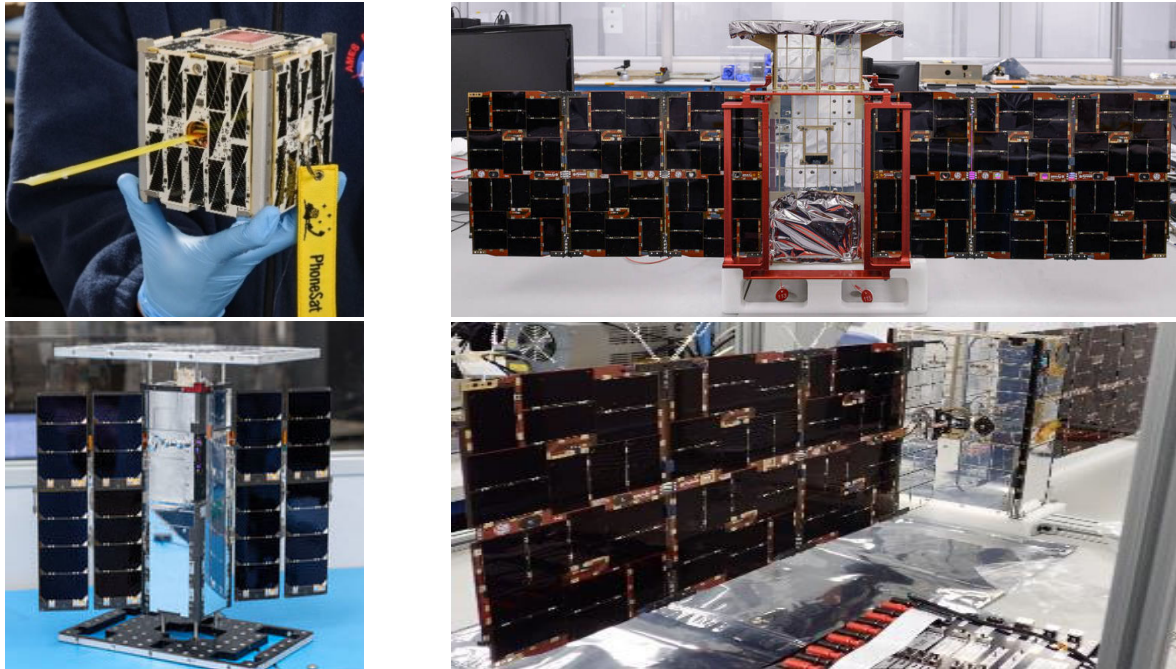


Figure 2.7: Examples of flown CubeSats. (Top left) 1U PhoneSat spacecraft, (top right) 12U CAPSTONE spacecraft, (lower left) 3U CLICK spacecraft, (lower right) 6U PTD-3 spacecraft. Credits: NASA and Terrain Orbital.

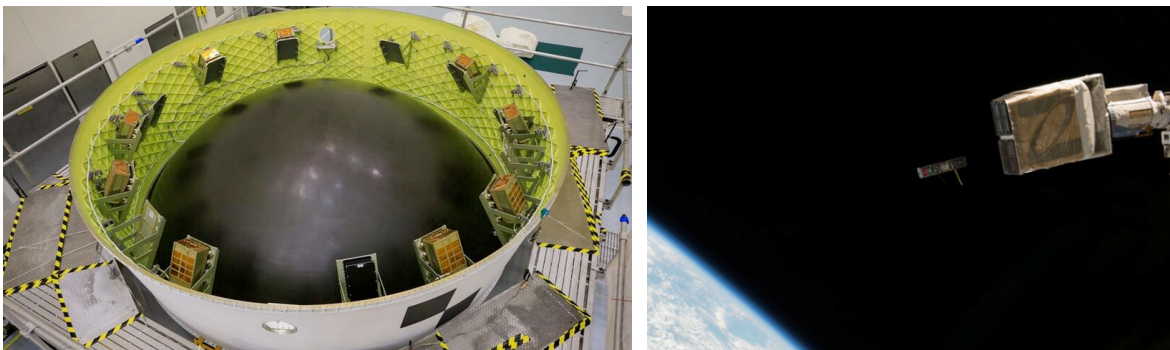


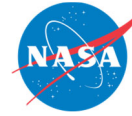
Figure 2.8: (left) Location of Artemis CubeSat deployers in between the Orion Crew Vehicle and the Interim Cryogenic Propulsion Stage (ICPS); (right) NASA Nodes mission deployment from ISS. Credit: NASA.



Table 2-4: 0.25U-3U Market Solutions

Organization	Peak Power (W)	3- $\sigma$ Pointing Control/ Knowledge	Comm Options	Intended Destination	Maturity	US Office
AAC Clyde Space <sup>Sweden</sup>	90	<0.1°/ <0.01°	VHF, UHF, S, X	LEO	Flown LEO	Yes
Alén Space <sup>Spain</sup>	180	0.2°/0.1°	VHF, UHF, S	LEO	Flown LEO	No
Artemis Space Technologies <sup>UK</sup>	50	0.01°/0.01°	UHF, S, X, Ka, Ku	Designed for LEO	Flown LEO	No
Blue Canyon Technologies <sup>USA</sup>	42	<0.021°/ <0.021°	L, S, X, Ka	LEO, GEO	Flown LEO Qualified GEO	Yes
C3S Electronics <sup>Hungary</sup>	35	0.2°/0.2°	UHF, S	LEO, MEO	Flown LEO	No
EnduroSat <sup>Bulgaria</sup>	30	<1°/ <0.6°	UHF, S, X	LEO	Flown LEO	Yes
German Orbital Systems <sup>Germany</sup>	24	Unk	S	Unk	Flown Unk	Unk
GomSpace <sup>Denmark</sup>	35	2.5°/2°	S	LEO	Flown LEO	Yes
GUMUSH AeroSpace <sup>Turkey</sup>	60	<2°/ <0.05°	VHF, UHF, X	LEO	Flown LEO	No
IMT <sup>Italy</sup>	3	10°/5°	VHF, UHF	LEO	Unk	Unk
ISISPACE <sup>The Netherlands</sup>	50	<15°/ <15°	VHF, UHF, S	LEO	Flown LEO	No
NanoAvionics <sup>Lithuania</sup>	175	4°/3.75°	UHF, S, X	LEO	Flown LEO	Yes
Near Space Launch <sup>USA</sup>	40	Unk	UHF, S	LEO	Flown LEO	Yes
NPC SPACEMIND <sup>Italy</sup>	50	Unk	UHF, S, X, Ka	LEO, MEO, GEO, Lunar	Flown LEO and MEO	No
Open Cosmos <sup>UK</sup>	160	2.4°/0.067°	UHF, S	LEO	Flown LEO	No
Orbital Astronautics <sup>UK</sup>	400	0.1°/ 0.01°	S, X, K, Ka, Optical	LEO, MEO	Flown LEO	No
Orion Space Solutions <sup>USA</sup>	Unk	Unk	Unk	Unk	Unk	Yes
Pumpkin Space Systems <sup>USA</sup>	200	0.05°/ <0.05°	UHF, S, X, Ka	LEO	Flown LEO	Yes
SatRev <sup>Poland</sup>	36	1°/0.6°	UHF, S	LEO	Flown LEO	No
SkyLabs <sup>Slovenia</sup>	100	0.3°/0.06°	VHF, UHF, S	LEO, MEO	Flown LEO and MEO	No
Space Flight Laboratory <sup>Canada</sup>	93	0.009°/0.004°	UHF, S, X, Ka	LEO, GEO, Lunar	Flown LEO	No





					Qualified GEO and Lunar	
Space Inventor <sup>Denmark</sup>	100	0.01 deg / 0.01 deg	VHF, UHF, S, X	LEO	Flown LEO	Unk
Spacemanic <sup>Czech Republic</sup>	30	0.1°/0.05°	VHF, UHF, S	LEO, GEO, Lunar	Flown LEO Qualified GEO	No
Spire Global <sup>USA</sup>	35	0.1°/0.05°	UHF, L, S, X	LEO	Flown LEO	Yes

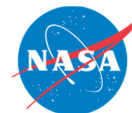


Table 2-5: 6U Market Solutions

Organization	Peak Power (W)	3- $\sigma$ Pointing Control/ Knowledge	Comm Options	Intended Destination	Maturity	US Office
AAC Clyde Space <sup>Sweden</sup>	150	<0.1°/<0.01°	VHF, UHF, S, X	LEO	Flown LEO	Yes
Alén Space <sup>Spain</sup>	180	0.2°/0.1°	VHF, UHF, S	LEO	Flown LEO	No
Argotec <sup>Italy</sup>	100	<0.07°/<0.03°	UHF, S, X, K	LEO, GEO, Lunar, Deep Space	Flown Deep Space Qualified Lunar	Yes
Artemis Space Technologies <sup>UK</sup>	100	0.01°/0.01°	UHF, S, X, Ka, Ku, Optical	LEO, MEO, GEO, Lunar, Deep Space	Flown LEO Qualified MEO, GEO, Lunar, and Deep Space	No
Blue Canyon Technologies <sup>USA</sup>	108	0.006°/0.006°	L, S, X, Ka	LEO, GEO, Lunar	Flown LEO Qualified GEO, and Deep Space	Yes
C3S Electronics Development <sup>Hungary</sup>	165	<0.2°/<0.2°	UHF, S	LEO, MEO	Under Development	No
EnduroSat <sup>Bulgaria</sup>	60	0.1°/0.05°	UHF, S, X	LEO	Flown LEO	Yes
German Orbital Systems <sup>Germany</sup>	72	Unk	S, X	Unk	Unk	Unk
GomSpace <sup>Denmark</sup>	102	0.07°/0.056°	S, X	LEO, Deep Space	Flown LEO Qualified Deep Space	Yes
IMT <sup>Italy</sup>	115	0.1°/0.1°	VHF, UHF, S, C, X	LEO	Unk	Unk
ISISPACE <sup>The Netherlands</sup>	100	<0.3°/<0.3°	UHF, S, X	LEO, Lunar	Flown LEO Qualified for Lunar	No
Millennium Space Systems <sup>USA</sup>	100	<0.03°/<0.014°	UHF, S	LEO	Flown LEO	Yes
NanoAvionics <sup>Lithuania</sup>	175	0.3°/0.15°	UHF, S, X	LEO	Flown LEO	Yes
Near Space Launch <sup>USA</sup>	40	Unk	UHF, S	LEO	Flown LEO	Yes
NPC SPACEMIND <sup>Italy</sup>	50	Unk	UHF, S, X, Ka	LEO, MEO, GEO, Lunar	Flown LEO	No
Open Cosmos <sup>UK</sup>	160	0.02°/0.01°	UHF, S, X	LEO	Qualified LEO	No

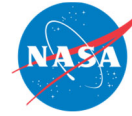


Orbital Astronautics <sup>UK</sup>	1,000	0.1°/0.01°	S, X, K, Ka, Optical	LEO, MEO	Flown LEO	No
Orion Space Solutions <sup>USA</sup>	Unk	Unk	Unk	Unk	Unk	Yes
Pumpkin Space <sup>USA</sup>	200	0.05°/<0.05°	UHF, S, X, Ka	LEO, Lunar	Flown LEO Qualified Lunar	Yes
SatRev <sup>Poland</sup>	36	1°/0.6°	UHF, S	LEO	Qualified LEO	No
SkyLabs <sup>Slovenia</sup>	200	0.3°/0.06°	VHF, UHF, S	LEO, MEO	Flown LEO and MEO	No
Space Dynamics Lab <sup>USA</sup>	50	0.021°/0.021°	S, X	LEO, GEO	Qualified LEO and GEO	Yes
Space Flight Laboratory <sup>Canada</sup>	240	0.009°/0.004°	UHF, S, X, Ka	LEO, GEO, Lunar	Flown LEO Qualified GEO and Lunar	No
Space Inventor <sup>Denmark</sup>	100	<0.008°/<0.008°	VHF, UHF, S, X	LEO	Flown LEO	Unk
Spacemanic <sup>Czech Republic</sup>	500	0.1°/0.05°	VHF, UHF, S	LEO, GEO, Lunar	Flown LEO Qualified GEO	No
Spire Global <sup>USA</sup>	40	0.1°/0.05°	UHF, L, S, X	LEO	Flown LEO	Yes
Terran Orbital <sup>USA</sup>	180	0.008°/0.007°	UHF, S, X, C	LEO, GEO, Deep Space	Flown LEO and Lunar Qualified GEO and Deep Space	Yes



Table 2-6: 12U Market Solutions

Organization	Peak Power (W)	3- $\sigma$ Pointing Control/ Knowledge	Comm Options	Intended Destination	Maturity	US Office
AAC Clyde Space <sup>Sweden</sup>	460	<0.1°/<0.01°	VHF, UHF, S, X, K, Ka, Ku, Optical	LEO	Qualified LEO	Yes
Argotec <sup>Italy</sup>	100	<0.07°/<0.03°	UHF, S, X, K	LEO, GEO, Lunar, Deep Space	Under Development	Yes
Artemis Space Technologies <sup>UK</sup>	150	0.01°/0.01°	UHF, S, X, Ka, Ku, Optical	LEO, MEO, GEO, Lunar, Deep Space	Flown LEO Qualified GEO, MEO, Lunar, and Deep Space	No
Blue Canyon Technologies <sup>USA</sup>	108	0.006°/0.006°	L, S, X, Ka	LEO, GEO, Lunar	Flown LEO and GEO Qualified Deep Space	Yes
C3S Electronics Development <sup>Hungary</sup>	165	<0.2°/<0.2°	UHF, S	LEO, MEO	Under Development	No
EnduroSat <sup>Bulgaria</sup>	70	0.1°/0.05°	UHF, S, X, K	LEO	Flown LEO	Yes
GomSpace <sup>Denmark</sup>	102	0.07°/0.056°	S, X	LEO	Qualified LEO	Yes
ISISPACE <sup>The Netherlands</sup>	190	<0.03°/<0.03°	UHF, S, X, Ka	LEO	Under Development	No
NanoAvionics <sup>Lithuania</sup>	175	0.3°/0.15°	UHF, S, X	LEO	Flown LEO	Yes
NPC SPACEMIND <sup>Italy</sup>	50	Unk	UHF, S, X, Ka	LEO, MEO, GEO, Lunar	Flown LEO	No
Open Cosmos <sup>UK</sup>	160	0.04°/0.035°	UHF, S, X	LEO	Qualified LEO	No
Orbital Astronautics <sup>UK</sup>	1,000	0.05°/0.01°	S, X, K, Ka, Optical	LEO, MEO	Qualified LEO	No
Pumpkin Space <sup>USA</sup>	400	0.05°/<0.05°	UHF, S, X, Ka	LEO, Lunar	Qualified LEO	Yes
SkyLabs <sup>Slovenia</sup>	500	0.3°/0.06°	VHF, UHF, S	LEO, MEO	Flown LEO and MEO	No
Space Dynamics Lab <sup>USA</sup>	80	0.021°/0.021°	S, X	LEO, GEO, GTO	Flown LEO Qualified GTO and GEO	Yes
Space Flight Laboratory <sup>Canada</sup>	322	0.009°/0.004°	UHF, S, X, Ka	LEO, GEO, Lunar	Flown LEO Qualified GEO and Lunar	No
Space Information Laboratories <sup>USA</sup>	180	0.008°/0.008°	S, X, Ka	LEO, GEO, Lunar	Under Development	Yes
Space Inventor <sup>Denmark</sup>	Unk	<0.008°/<0.008°	VHF, UHF, S, X	LEO	Flown LEO	Unk



Spacemanic <sup>Czech Republic</sup>	500	0.1°/0.05°	VHF, UHF, S, X	LEO, GEO, Lunar	Flown LEO Qualified GEO	No
Spire Global <sup>USA</sup>	300	0.1°/0.05°	UHF, L, S, X, Ku	LEO	Under Development	Yes
Terran Orbital <sup>USA</sup>	180	0.008°/0.007°	UHF, S, X, C	LEO, GEO, Lunar, Deep Space	Flown LEO and Lunar Qualified GEO and Deep Space	Yes



Table 2-7: 16U+ Market Solutions

Organization	Format	Peak Power (W)	3- $\sigma$ Pointing Control/ Knowledge	Comm Options	Intended Destination	Maturity	US Office
AAC Clyde Space <sup>Sweden</sup>	16U	460	<0.1°/ <0.01°	VHF, UHF, S, X, K, Ka, Ku, Optical	LEO	Qualified LEO	Yes
Argotec <sup>Italy</sup>	27U	250	<0.07°/ <0.03°	UHF, S, X, K	LEO, Lunar	Under Development	Yes
Artemis Space Technologies <sup>UK</sup>	16U	200	0.01°/0.01°	UHF, S, X, Ka, Ku, Optical	LEO, MEO, GEO, Lunar, Deep Space	Flown LEO Qualified GEO, MEO, Lunar, and Deep Space	No
C3S Electronics <sup>Hungary</sup>	16U+	165	<0.2°/ <0.2°	UHF, S	LEO, MEO	Under Development	No
German Orbital Systems <sup>Germany</sup>	16U	164	Unk	X	Unk	Unk	Unk
GomSpace <sup>Denmark</sup>	16U	150	0.07°/0.056°	S, X	LEO	Qualified LEO	Yes
ISISPACE <sup>The Netherlands</sup>	16U	190	<0.03°/ <0.03°	UHF, S, X, Ka	LEO	Under Development	No
NanoAvionics <sup>Lithuania</sup>	16U	175	0.3°/0.09°	UHF, S, X	LEO	Flown LEO	Yes
NPC SPACEMIND <sup>Italy</sup>	16U	50	Unk	UHF, S, X, Ka	LEO, MEO, GEO, Lunar	Under Development	No
Open Cosmos <sup>UK</sup>	16U	160	0.04°/0.035°	UHF, S, X	LEO	Qualified LEO	No
Orbital Astronautics <sup>UK</sup>	16U, 27U	1,000	0.05°/0.01°	S, X, K, Ka, Optical	LEO, GEO, Lunar	Qualified LEO	No
Pumpkin Space <sup>USA</sup>	16U, 27U	400	0.05°/ <0.05°	UHF, S, X, Ka	LEO, Lunar	Qualified LEO	Yes
SkyLabs <sup>Slovenia</sup>	20U+	500	<0.005°/ <0.003°	VHF, UHF, S	LEO, MEO	Flown LEO and MEO	No
Space Flight Laboratory <sup>Canada</sup>	16U	322	0.009°/0.004°	UHF, S, X, Ka	LEO, GEO, Lunar	Flown LEO Qualified GEO and Lunar	No
Space Information Laboratories <sup>USA</sup>	27U	180	0.008°/0.008°	S, X, Ka	LEO, GEO, Lunar	Under Development	Yes
Space Inventor <sup>Denmark</sup>	16U	Unk	<0.008°/ <0.008°	VHF, UHF, S, X	Unk	Unk	Unk
Spacemanic <sup>Czech Republic</sup>	16U, 27U	1,000	0.1°/0.05°	VHF, UHF, S, X	LEO, GEO, Lunar	Flown LEO Qualified GEO and Lunar	No
Spire Global <sup>USA</sup>	16U	300	0.1°/0.05°	UHF, L, S, X, Ku	LEO	Under Development	Yes

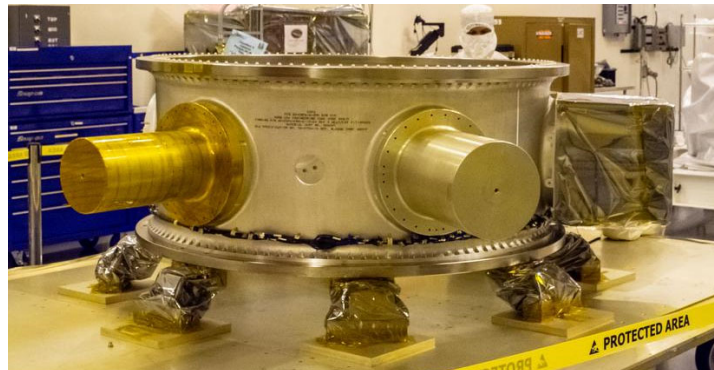
### 2.2.2.2 ESPA-Class

The term ESPA-class refers to the Evolved Expendable Launch Vehicle (EELV) Secondary Payload Adapter (SPA) or similar configurations. The ESPA ring typically separates the primary payload with the upper stage of the launch vehicle, permitting additional mounting allocations for secondary payloads. Multiple rings can be stacked without a primary payload on the top to launch multiple payloads.

For this document, the ESPA-class table 2-8 includes options that may not be designed for the ESPA ring, but its mass and volume permit adaptability to this rideshare opportunity. The information in this chapter is limited to offerings with mass under 500 kg even though some variants of the ESPA ring can support higher mass. Variants of the ESPA ring include, but are not limited to, ESPA-Heavy and ESPA-Grande. Examples of ESPA Rideshare are provide in figure 2.9 and 2.10.



*Figure 2.9: Example Mission Configuration using Rideshare Plates. Credit: SpaceX.*



*Figure 2.10: LandSat-9 ESPA Ring Populated with Payloads and Mass Ballasts. Credit: NASA/Randy Beaudoin.*



Table 2-8: ESPA-Class Market Solutions

Organization	Peak Power (W)	3- $\sigma$ Pointing Control/ Knowledge	Comm Options	Intended Destination	Maturity	US Office
Airbus <sup>USA</sup>	3,000	0.3°/0.3°	S, Ka, Optical	LEO	Flown LEO	Yes
Artemis Space Technologies <sup>UK</sup>	1,250	0.01°/0.01°	UHF, S, X, Ka, Ku, Optical	LEO, MEO, GEO, Lunar, Deep Space	Qualified LEO, MEO, GEO, Lunar and Deep Space	No
Astranis Space Technologies Corp. <sup>USA</sup>	1,500	<0.1°/<0.01°	Ka, Ku, Q, V, X	MEO, GEO, Cislunar, Deep Space	Qualified GEO	Yes
Ball Aerospace <sup>USA</sup>	500	<0.02°/<0.002°	L, S, X, Ka	LEO, MEO, GEO	Flown LEO	Yes
Berlin Space Technologies <sup>Germany</sup>	3000	<0.017°/<0.017°	UHF, S, X, Ka, Ku, W	LEO	Flown LEO	No
Blue Canyon Technologies <sup>USA</sup>	1,082	0.006°/0.006°	L, S, X, Ka	LEO, GEO, Deep Space	Flown LEO and GEO Qualified Deep Space	Yes
Bradford Space <sup>USA</sup>	1,500	1.5°/0.006°	S, K	LEO, GEO, GTO, Cislunar, Lunar, Deep Space	Under Development	Yes
CesiumAstro <sup>USA</sup>	3,000	<0.1°/<0.01°	S, L, Ku, Ka, Optical	LEO	Under Development	Yes
Hemeria <sup>France</sup>	200	<0.03°/<0.01°	S, X	LEO, GEO	Unk	Unk
LeoStella <sup>USA</sup>	2,000	0.005°/0.004°	UHF, S, X	LEO	Flown LEO	Yes
Lockheed Martin <sup>USA</sup>	400	<0.1°/<0.1°	S, X	LEO, Lunar, Deep Space	Under Development LEO and Lunar Qualified Deep Space	Yes
Loft Orbital <sup>USA</sup>	1,100	<0.045°/<0.015°	S, X, L	LEO	Flown LEO	Yes
Magellan Aerospace <sup>Canada</sup>	100	<0.2°/<0.02°	S	LEO	Flown LEO	No
Malin Science Space Systems <sup>USA</sup>	918	<0.015°/<0.015°	UHF, X, Ka	Mars	Under Development	Yes
Millennium Space Systems <sup>USA</sup>	500	<0.013°/<0.008°	S, X, Ka	LEO, MEO, GEO, Deep Space	Flown LEO and GEO	Yes
NanoAvionics <sup>Lithuania</sup>	1,200	0.15°/0.03°	UHF, S, X	LEO	Flown LEO	Yes





Northrop Grumman <sup>USA</sup>	400	<0.01°/ <0.008°	S, X, Ka	LEO, GEO, HEO	Flown LEO, GEO, and HEO	Yes
NovaWurks <sup>USA</sup>	>5,000	0.002°/0.0004°	UHF, S, L, X, Ka, Ku and Optical	LEO, MEO, GEO, GTO, HEO, Lunar and Deep Space	Flown LEO and GTO	Yes
Orbital Astronautics <sup>UK</sup>	5,000	0.05°/0.01°	S, X, K, Ka, Optical	LEO, MEO	Qualified LEO	No
Qinetiq <sup>Belgium</sup>	600	0.005°/0.0017°	X	LEO	Qualified LEO	Yes
Redwire Space <sup>USA</sup>	220	0.03°/0.005°	S, X, Ka	LEO	Qualified LEO	
SITAEL <sup>Italy</sup>	750	0.017°/0.010°	S, X, Ka	LEO	Under Development	No
Southwest Research Institute <sup>USA</sup>	2,700	0.009°/0.002°	S, X, Ka	LEO, GEO	Flown LEO Under Development GEO	Yes
Space Dynamics Lab <sup>USA</sup>	1,600	0.021°/0.021°	S, X	LEO	Flown LEO	Yes
Space Flight Laboratory <sup>Canada</sup>	1,200	0.009°/0.004°	UHF, S, X, Ka	LEO, GEO, Lunar	Flown LEO Qualified GEO and Lunar	No
Space Inventor <sup>Denmark</sup>	Unk	<0.008°/ <0.008°	VHF, UHF, S, X	Unk	Unk	Unk
Terran Orbital <sup>USA</sup>	4,000	0.003°/0.002°	UHF, S, X, C	LEO, GEO, Lunar and Deep Space	Under Development	Yes
XPLORE <sup>USA</sup>	950	0.17°/ 0.018°	S, X	VLEO, LEO, Cislunar	Under Development	Yes
York Space Systems <sup>USA</sup>	1,500	0.008°/0.004°	UHF, S, X, Ka, Ku, Optical	LEO, GEO, Lunar	Flown LEO Qualified GEO and Lunar	Yes



## 2.3 Programmatic and Systems Engineering Considerations

To make an appropriate decision on which design path to take, small satellite mission developers should consider the programmatic and Systems Engineering factors most important to them, such as:

- What are the environments the system will be exposed during development and in flight?
- Are the Concept of Operations well defined and understood?
- How well do the systems meet functional and performance requirements?
- What are the mission's key performance parameters (e.g., mass, volume, power, data link, data budget, pointing) and how much margin do they offer?
- What is the software development environment, and how much flight and ground software can be re-used? Are emulators, simulators, Engineering Development Units (EDUs) and/or flatsats available to aid that development?
- What are the systems'/components' flight heritage, Technology Readiness Level (TRL), and reliability? What is the remaining Research and Development (R&D) level of effort to integrate the system with existing and/or planned systems?
- What is the mission's risk posture? How much development risk and performance risk are acceptable to the mission?
- Is it most important to meet performance requirements, cost, and/or schedule? What is the system's/components' production/lead time, and what are the contractual mechanisms that will be used to procure the systems and ensure timely delivery if delays are encountered?

Design selection can be driven by unique mission constraints, manufacturing lead time, and documented reliability. All of these and many more considerations should be well understood for each trade space option prior to a down-select. Given mission system performance requirements for key performance parameters like mass, volume, power, data link, data budget, and pointing, a functional importance rating and risk-based trade study should be used to screen the many options available. In addition to functional performance, relevant flight heritage or TRL, production lead time, and any available reliability data should be included in the trades. These, as well as cost, could drive the design to be done via COTS or commercial support.

Mission developers may want to take into consideration the following guides to help them in their selection and design process:

- NASA CubeSat 101 Book <https://www.nasa.gov/content/cubesat-launch-initiative-resources>
- NASA Systems Engineering Handbook <https://www.nasa.gov/connect/ebooks/nasa-systems-engineering-handbook>
- NASA Small Spacecraft Technology program Guidebook for Technology Development Projects [https://www.nasa.gov/sites/default/files/atoms/files/smallsattechdevguidebook\\_rev-508d1.pdf](https://www.nasa.gov/sites/default/files/atoms/files/smallsattechdevguidebook_rev-508d1.pdf)

## 2.4 On the Horizon

As spacecraft buses are combinations of the subsystems described in later chapters, it is unlikely there will be any revolutionary changes in this chapter that are not preceded by revolutionary changes in some other chapter. As launch services become less expensive and commonplace with the rise of dedicated SmallSats launches, the market will continue to expand allowing interested universities and researchers to purchase COTS spacecraft platforms as an alternative to developing and integrating SmallSats themselves. Another option is to use numerous turnkey solutions offered by SmallSat vendors who can customize and cater to customer constraints.



SmallSat subsystem technology will continue to mature and gain flight heritage, to produce improved next generation platforms offered by vendors. Platforms with increased performance will spark the interest of newer vendors as they emerge into the market. This was demonstrated in the PocketQube industry: the requirement to satisfy ultra-low mass and volume constraints enabled high-performance capabilities. As the industry grows, there will likely be key technological advancements in SmallSat in-space propulsion, pointing and navigation control, optical communications, radiation tolerance, and radiation hardening. Subsystems described in other chapters in this report include details on radiation testing, but a subsystems' mean time between failures (MTBF) and overall system reliability will become a key design criterion as the sample groups become large enough to be statistically significant.

The Aerospace Corporation is currently working on a new spacecraft platform standard that can potentially revolutionize and/or expand the SmallSat industry. The DiskSat is a quasi-two-dimensional satellite bus architecture designed for applications requiring high power, large apertures, and/or high maneuverability in a low-mass containerized satellite. A representative DiskSat structure is a composite flat panel, one meter in diameter and 2.5 cm thick. The volume is almost 20 liters, equivalent to a hypothetical 20U CubeSat, while the structural mass is less than 3 kg. The surface area is large enough to host over 200 W of solar cells without deployable solar panels. With support of NASA Space Technology Mission Directorate's (STMD) Small Spacecraft Technology (SST) program, preparations are underway for a 2024 flight. The launch will consist of four DiskSats stacked in a fully enclosed container/deployer, released individually in orbit using a simple mechanical interface. This will demonstrate the feasibility and validity of both the dispenser and the DiskSat bus. In addition, the flight is expected to demonstrate several features of the DiskSat including the unprecedented high power-to-mass ratio, the maneuverability of the bus using low-thrust electric propulsion, and the ability to fly continuously in a low-drag orientation, enabling operations in very low Earth orbits (VLEO) (Welle, 2022, p.1)

## 2.5 Summary

Several vendors have pre-designed fully integrated small spacecraft buses that are space rated and available for purchase. The market ranges from companies that are willing to heavily modify their systems to fit the customer's needs to companies attempting to standardize their system with little to no customization in favor of a better cost proposition. This chapter consolidated a long list of providers with key characteristics to facilitate the research and down-selection process for SmallSat practitioners.

For feedback about this chapter, email: [arc-sst-soa@mail.nasa.gov](mailto:arc-sst-soa@mail.nasa.gov). Please include a business email in case of follow up questions.

## 2.6 References

The references in this section are provided to facilitate the process in which practitioners can obtain information from the providers. The source indicates how the information provided in this chapter was obtained.

Source definition:

**Direct** = organization provided the information through direct communication with the State-of-the-Art team.

**Website** = the team was unable to directly communicate with the organization and limited information was obtained from the organization's website.

Reference for in-text citation:



Welle, R. (2022, August). *DiskSat: Demonstration Mission for a Two-Dimensional Satellite Architecture*, Small Satellite Conference 2022, Utah, USA.

<b>Table 2-9: List of Contact Information for Organizations in this Chapter</b>			
<b>Organization</b>	<b>Source</b>	<b>Contact Email</b>	<b>Website</b>
AAC Clyde Space	Direct	enquiries@aac-clydespace.com	www.aac-clyde.space
Airbus	Direct	deborah.horn@airbusus.com	-
Alba Orbital	Direct	contact@albaorbital.com	www.albaorbital.com
Alen Space	Direct	sales@alen.space	www.alen.space
Argotec	Direct	info@argotecgroup.com	www.argotecgroup.com
Artemis Space Technologies	Direct	info@spaceartemis.com	www.spaceartemis.com
Astranis	Direct	scott@astranis.com	www.astranis.com
Ball Aerospace	Direct	<a href="#">General Inquiry Form</a>	www.ballaerospace.com
Berlin Space Technologies	Direct	info@berlin-space-tech.com	www.berlin-space-tech.com
Blue Canyon Technologies	Direct	info@bluecanyontech.com	www.bluecanyontech.com
Bradford Space	Direct	info@bradford-space.com	Bradford-Space.com
C3S Electronics Development	Direct	info@c3s.hu	www.c3s.hu
CesiumAstro	Direct	info@cesiumastro.com	www.cesiumastro.com
Citadel Space Systems	Website	contact@citadel.space	Citadel.space
DIYSATELLITE	Direct	gus@diysatellite.com	www.diysatellite.com
EnduroSat	Direct	<a href="#">Contact Page</a>	www.endurosat.com
FOSSA Systems	Direct	contact@fossa.systems	Fossa.systems
General Atomics	Direct	Chris.white@ga.com	www.ga.com/EMS
German Orbital Systems	Website	info@orbitalsystems.de	www.orbitalsystems.de
GomSpace	Direct	info@gomspace.com	gomspace.com
GUMUSH AeroSpace	Direct	gumush@gumush.com.tr	www.gumush.com.tr
Hemeria	Website	contact@hemeria-group.com	www.hemeria-group.com/en
IMT	Website	imtsrl@imtsrl.it	imtsrl.it
Innova Space	Website	info@innova-space.com	innova-space.com/en
In-Space Missions	Website	info@in-space.co.uk	in-space.co.uk
ISISPACE	Direct	sales@isispace.nl	www.isispace.nl
LeoStella	Direct	info@leostella.com	leostella.com
Lockheed Martin	Direct	timothy.m.linn@lmco.com	-
Loft Orbital	Direct	andrew@loftorbital.com	www.loftorbital.com
Magellan Aerospace	Direct	rushi.ghadawala@magellan.aero	www.magellan.aero
Malin Space Science Systems	Direct	yee@msss.com	www.msss.com
Millennium Space Systems	Direct	<a href="#">Contact Webpage</a>	www.millennium-space.com
Mini-Cubes	Website	info@mini-cubes.com	Mini-cubes.com
Momentum	Direct	sales@momentus.space	Momentum.space
Nanoavionics	Direct	info@nanoavionics.com	www.nanoavionics.com
Near Space Launch	Website	nsl@nearspacelaunch.com	www.nearspacelaunch.com

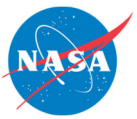


Northrop Grumman	Direct	John.Dyster@ngc.com	-
NovaWurks	Direct	info@NovaWurks.com	www.novawurks.com
NPC SPACEMIND	Direct	info@npcspacemind.com	www.npcspacemind.com
Open Cosmos	Direct	partnerships@open-cosmos.com	open-cosmos.com
Orbital Astronautics	Direct	hello@orbastro.com	orbastro.com
Orion Space Solutions	Website	contact@orionspace.com	orionspace.com
Pumpkin Space Systems	Direct	sales@pumpkininc.com	www.pumpkinspace.com
Qinetiq	Direct	info@qinetiq.be	qinetiq.com/en/markets/space
Redwire Space	Direct	sales@redwirespace.com	www.redwirespace.com
SatRev	Direct	engage@satrev.space	www.satrev.space
SITAEL	Direct	sales.space@sitael.com	www.sitael.com
SkyLabs	Direct	sales@skylabs.si	www.skylabs.si
Southwest Research Institute	Direct	spacecraft-info@swri.org	-
Space Dynamics Lab	Direct	info@sdl.usu.edu	www.sdl.usu.edu
Space Flight Laboratory	Direct	info@utias-sfl.net	www.utias-sfl.net
Space Information Laboratories	Direct	sales@spaceinformationlabs.com	www.spaceinformationlabs.com
Space Inventor	Website	sales@space-inventor.com	space-inventor.com
Spacemanic	Direct	sales@spacemanic.com	www.spacemanic.com
Spire Global	Direct	<a href="#">Talk to Sales</a>	www.spire.com
Terran Orbital	Direct	info@terranorbital.com	terranorbital.com
Xplore	Direct	inquire@xplore.com	www.xplore.com
York Space Systems	Direct	BD@yorkspacesystems.com	www.yorkspacesystems.com



## Chapter Contents

Chapter Glossary .....	ii
3.0 Power .....	26
3.1 Introduction .....	26
3.2 State-of-the-Art – Power Generation .....	27
3.2.1 Solar Cells .....	28
3.2.2 Solar Panels & Arrays .....	30
3.3 On the Horizon – Power Generation .....	32
3.3.1 Multi-junction Solar Cells .....	33
3.3.2 Flexible Solar Cells .....	33
3.3.3 Organic Solar Cells .....	33
3.3.4 Fuel Cells .....	34
3.4 State-of-the-Art – Energy Storage .....	34
3.4.1 Secondary Li-ion and Lipo Batteries .....	37
3.5 On the Horizon – Energy Storage .....	40
3.5.1 Supercapacitors .....	41
3.5.2 Solid-State Batteries .....	43
3.5.3 Batteries for Low-Temperature Applications .....	44
3.6 State-of-the-Art – Power Management and Distribution .....	44
3.7 On the Horizon – Power Management and Distribution .....	49
3.7.1 Modular Architecture .....	49
3.7.2 Wireless Power Transfer and Telemetry .....	49
3.8 Summary .....	49
References .....	50



## Chapter Glossary

(AFRL)	Air Force Research Laboratory
(BMS)	Battery Management System
(BOL)	Beginning-of-Life
(CFRPs)	Composite Fiber Reinforced Panels
(CIGS)	Cu(In,Ga)Se <sub>2</sub>
(COTS)	Commercial-off-the-Shelf
(EOL)	End-of-Life
(EPS)	Electrical Power System
(ESA)	European Space Agency
(GaN)	Galium Nitride
(GRC)	NASA Glenn Research Center
(KSC)	Kennedy Space Center
(Li-ion)	Lithium-ion
(LiCF <sub>x</sub> )	Lithium carbon monofluoride
(LiPo)	Lithium polymer
(LiSO <sub>2</sub> )	Lithium sulfur dioxide
(LiSOCl <sub>2</sub> )	Lithium thionyl chloride
(MIL)	Military
(QML)	Qualified Manufacturers List
(NiCd)	Nickel-cadmium
(NiH <sub>2</sub> )	Nickel-hydrogen
(OPV)	Organic Photovoltaic
(OSCAR)	Optical Sensors based on carbon materials
(PCB)	Printed Circuit Board
(PEASSS)	Piezoelectric Assisted Smart Satellite Structure
(PET)	polyethylene terephthalate
(PMAD)	Power management and distribution
(RHUs)	Radioisotopic Heater Units
(RTGs)	Radioisotope Thermoelectric Generators
(SABER)	Solid-state Architecture Batteries for Enhanced Rechargeability and Safety
(SWaP)	Size, Weight, and Power
(TPV)	Thermophotovoltaic



(TR) Thermoradiative  
(TRL) Technology Readiness Level  
(Wh kg<sup>-1</sup>) Watt hours per kilogram





## 3.0 Power

### 3.1 Introduction

The electrical power system (EPS) encompasses electrical power generation, storage, and distribution. The EPS is a major, fundamental subsystem, and commonly comprises a large portion of volume and mass in any given spacecraft. Power generation technologies include photovoltaic cells, panels and arrays, and radioisotope or other thermonuclear power generators. Power storage is typically applied through batteries; either single-use primary batteries or rechargeable secondary batteries. Power management and distribution (PMAD) systems facilitate power control to spacecraft electrical loads. PMAD takes a variety of forms and is often custom-designed to meet specific mission requirements. EPS engineers often target a high specific power or power-to-mass ratio ( $\text{Wh kg}^{-1}$ ) when selecting power generation and storage technologies to minimize system mass. The EPS volume is most likely to be the constraining factor for nanosatellites.

CubeSats and SmallSats typically operate in a mild radiative environment for short periods in low-Earth orbits, so stringent qualification standards and high Technology Readiness Level (TRL) don't tend to carry a lot of weight on those missions unlike in deep space. Therefore, EPS engineers should note some fundamental differences between commercial-off-the-shelf (COTS) parts and space-qualified parts while weighing those differences against spacecraft requirements. Typically, Military or Space (MIL/QML) qualified parts go through a series of specific tests, while COTS go through less stringent ones. For example, Military or Space parts are typically tested and qualified to survive  $-55^{\circ}\text{C}$  to  $125^{\circ}\text{C}$ , while the alternative COTS requirement is  $-40^{\circ}\text{C}$  to  $85^{\circ}\text{C}$ . The same trend is true for other factors that are a part of the MIL/QML qualification process like radiation, reliability, etc. COTS parts are typically known to have higher performance, while space qualified parts typically have relatively higher reliability. Another key limitation in QML parts is their lack of availability and slow revision timeline. All in all, we find that COTS parts are in many cases more suitable for use in SmallSat designs.

In this chapter, the terms SmallSat and CubeSat are often used in the same context, however, the reader needs to be aware of the distinctions between the two types of spacecraft. Please refer to the introduction of this report for more information on the categories of SmallSats. CubeSats fall under the category of both microsatellites and nanosatellites, and CubeSat missions commonly use COTS parts for space applications. Due to their nearly exclusive use in low-Earth orbit applications, CubeSats are more likely to incorporate COTS parts as they typically feature shorter mission lengths, more favorable environmental conditions, and as a result, need less stringent standards when qualifying parts. Knowing the distinction between a CubeSat and a SmallSat is necessary for determining the potential for incorporating COTS parts in a SmallSat design.

The information described below is not intended to be exhaustive but provides an overview of current state-of-the-art technologies and their development status for a particular small satellite subsystem. It should be noted that TRL designations may vary with changes specific to the payload, mission requirements, reliability considerations, and/or the environment in which performance was demonstrated. Readers are highly encouraged to reach out to companies for further information regarding the performance and TRL of the described technology. There is no intention of mentioning certain companies and omitting others based on their technologies or relationship with NASA.

In this chapter we will review the following categories:

- Power Generation-- including solar cells, panels and arrays (Sections 3.2 & 3.3),
- Energy Storage-- including Li-ion, Lipo, supercapacitors and solid-state batteries (Sections 3.4 & 3.5), and
- Power Management-- including modular architectures and wireless power transfer and telemetry (Sections 3.6 & 3.7).

### 3.2 State-of-the-Art – Power Generation

Power generation on SmallSats is a necessity typically governed by a common solar power architecture (solar cells + solar panels + solar arrays). As the SmallSat industry drives the need for lower cost and increased production rates of space solar arrays, the photovoltaics industry is shifting to meet these demands. The standardization of solar array and panel designs, deployment mechanisms, and power integration will be critical to meet the desire for large, proliferated constellations.

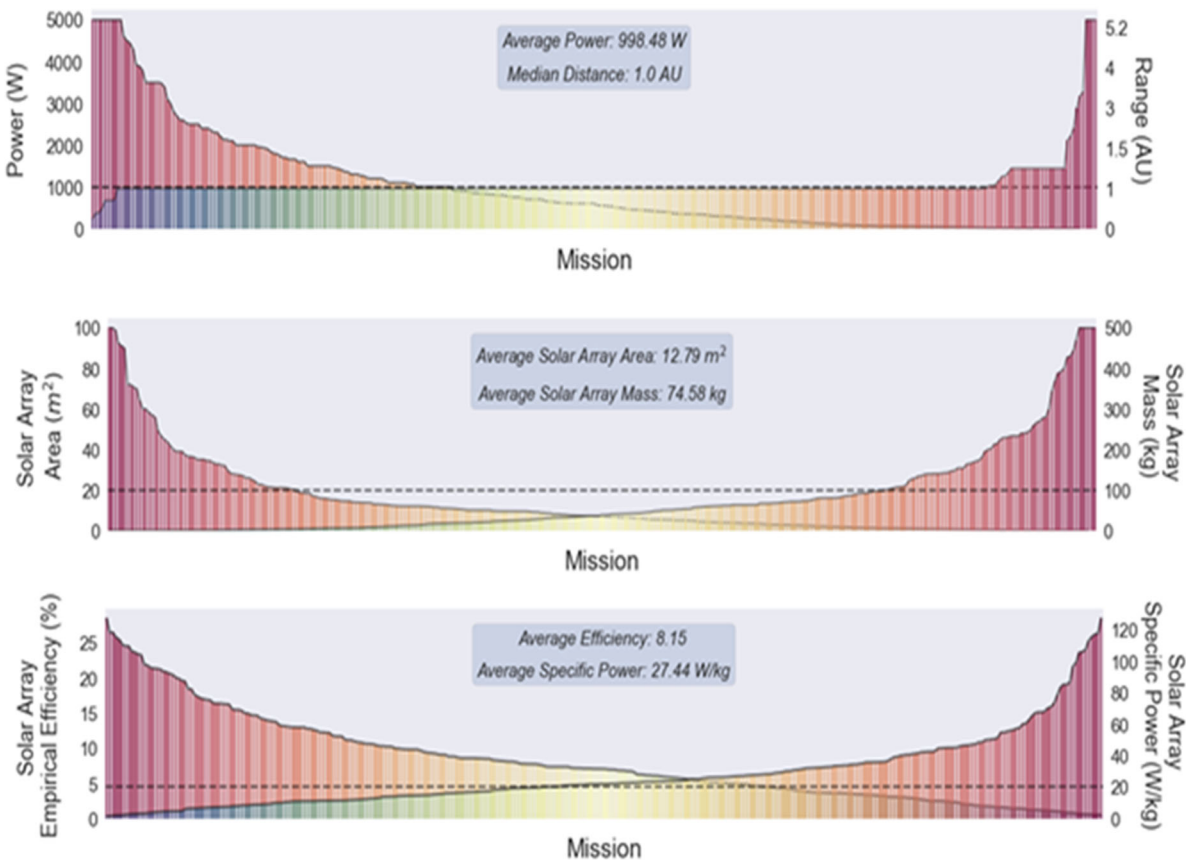
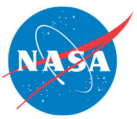


Figure 3.1: (Top) Distribution of mission ranges, or the furthest point from the sun that the spacecraft reaches, and mission power levels [power capped at 5 KW]. (Middle) Distribution of solar array surface area and solar array mass [mass capped at 500 Kg]. (Bottom) Distribution of solar array empirical efficiency (calculated at Earth) and specific power (for the entire array measured at the destination of the mission), Peretz et al. 2022 (92). Credit: NASA.



EPS engineers should note beginning-of-life (BOL) vs end-of-life (EOL) performance of the systems as well as their planned testing hours for such systems while on the ground prior to operations. Typically, EPS for SmallSats is over-engineered to handle a dynamic thermal environment, eclipse durations while in LEO, or any other operational scenarios or mission needs while in eclipse at varying sun-angles. Figure 3.1 captures actual space system performances given such wide varying operational conditions for all reviewed space missions (not only SmallSats) launched since 1989 to 2021.

In SmallSat missions especially, cost and scheduling considerations are something that EPS engineers must pay attention to on a component level, and power generation components are no exception. When possible, choosing a pre-designed and qualified panel is preferred over designing unique solar panels to reduce the cost and schedule as well as unforeseen design and manufacturing issues. Companies that have the capacity for mass production and automation are rare because space solar arrays, cells, and panels have always been a 'boutique' business; however, standardized designs like the OneWeb and StarLink constellations have been appearing more often to meet the demands of highly proliferated constellations.

The following subsections aim to capture the current state of the art and assist EPS engineers, mission designers, system engineers, etc., in designing, reviewing and ultimately constructing and operating such power flight systems.

### **3.2.1 Solar Cells**

Solar power generation is the predominant method of power generation on small spacecraft. As of 2021, over 90% of all nanosatellite/SmallSat form factor spacecraft were equipped with solar panels and rechargeable batteries (Peretz et al 2022). Limitations to solar cell use include diminished efficacy in deep-space applications, no generation during eclipse periods, degradation over mission lifetime (due to aging and radiation), high surface area, mass, and cost. To pack more solar cells into the limited volume of SmallSats and NanoSats, mechanical deployment mechanisms can be added, which may increase spacecraft design complexity, reliability, as well as risk. Photovoltaic cells, or solar cells, are made from thin semiconductor wafers that produce an electric current when exposed to light. The light available to a spacecraft solar array, also called solar intensity, varies as the inverse square of the distance from the Sun. The projected surface area of the panels exposed to the Sun also affects power generation and varies as a cosine of the angle between the panel and the Sun.

While single-junction cells are cheap to manufacture, they carry a relatively low efficiency, usually around 20%, and are not included in this report. Modern spacecraft designers favor multi-junction solar cells made from multiple layers of light-absorbing materials that efficiently convert specific wavelength regions of the solar spectrum into energy, thereby using a wider spectrum of solar radiation (1). The theoretical efficiency limit for an infinite-junction cell is 86.6% in concentrated sunlight (2). However, in the aerospace industry, triple-junction cells are commonly used due to their high efficiency-to-cost ratio compared to other cells.

The current state of the art for space solar cells are multi-junction cells ranging from 3 to 5 junctions based on Group III-V semiconductor elements (like GaAs). SmallSats and CubeSats typically use some of the highest performing cells that provide efficiencies over 32%, even though they have a substantially higher cost than terrestrial silicon solar cells (~20% efficient). Ultimately the size, weight, and volume of smaller satellites may be the determining factor in choosing solar cell technology, rather than solar cell efficiency. Being a life-limiting component on most spacecraft, the EOL performance at operating temperature is critical in evaluating their performance. Common factors that degrade the functionality of solar cells include radiation exposure, coverglass/adhesive darkening, contamination, and mechanical or electrical failure.



This section individually covers small spacecraft targeted cells, fully integrated panels, and arrays. Table 3-1 itemizes small spacecraft solar cell efficiency per the available manufacturers. Note the efficiency may vary depending on the solar cells chosen.

<b>Table 3-1: Solar Cells Product Table</b>								
<b>Company</b>	<b>Cell Name</b>	<b>BOL Efficiency</b>	<b>Voc (V)</b>	<b>Vmp (V)</b>	<b>Jsc (mA/cm<sup>2</sup>)</b>	<b>Jmp (mA/cm<sup>2</sup>)</b>	<b>Pmp (W/m<sup>2</sup>)</b>	<b>Ref</b>
AZUR Space	Silicon S 32	16.8	0.628	0.528	45.8	43.4	229.2	(3)
	3G30-Adv	29.5	2.7	2.411	17.2	16.71	403	(3)
	4G32-Adv	31.5	3.426	2.999	15.2	14.37	431	(3)
	TJ 3G28C	28	2.667	2.37	16.77	16.14	1367	(3)
SolAero	ZTJ	29.5	2.726	2.41	17.4	16.5	397.7	(10)
	ZTJ+	29.4	2.69	2.39	17.1	16.65	397.9	(10)
	ZTJ Omega	30.2	2.73	2.43	17.4	16.8	408.2	(10)
	Z4J	30.0	3.95	3.54	12	11.5	407.1	(10)
	IMM $\alpha$	32.0	4.78	4.28	10.7	10.12	433.1	(10)
	ZTJM	29.5	2.72	2.38	17.1	16.5	392	(10)
SpectroLab	XTJ	29.5	2.633	2.348	17.76	17.02	399.6	(6)
	XTJ-Prime	30.7	2.715	2.39	18.1	17.4	415.9	(6)
	XTE-SF	32.2	2.75	2.435	18.6	17.8	433.4	(5)
	XTE-HF	32.1	2.782	2.49	18	17.4	427.9	(5)
	XTE-LILT	31.6	2.755	2.459	18.1	17.4	427.9	(5)
	UTJ	28.4	2.66	2.35	17.14	16.38	384.93	(7)
	TASC	27	2.52	2.19	32	28	270	(8)
	ITJ	26.8	2.565	2.27	16.9	16	1353	(9)
Emcore	BTJ	28.5	2.7	2.37	17.1	16.3	386	(4)
Emcore	ZTJ	29.5	2.726	2.41	17.4	16.5	397	(4)

### 3.2.2 Solar Panels & Arrays

Solar panels & arrays are constructed from individual solar cells connected in series to form strings and in parallel to form circuits mounted on a substrate backing (e.g., figure 3.2). While very low-power CubeSats and SmallSats may only need body-mounted solar panels, most will require more power from deployed solar arrays. The deployed solar arrays for CubeSats and SmallSats are mostly on rigid substrates made of either a printed circuit board (PCB), composite fiber reinforced panels (CFRPs), or an aluminum honeycomb panel.

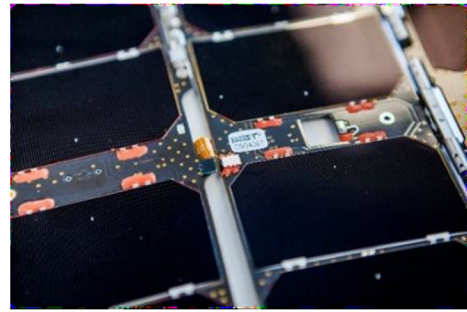


Figure 3.2: AAC Clyde Space solar arrays. Credit: AAC Clyde Space.

Deployed solar arrays are often the largest structure on a satellite; the ratio between the size of the deployed solar array and the size of the SmallSat may be much higher compared to other conventionally large spacecraft. The size and fundamental frequency of the solar arrays impact spacecraft pointing, propulsion, and delta-V needed for station keeping. Important considerations for SmallSat solar arrays are deployment mechanisms, deployed frequency, panel specific power, and power density, as well as stowed volume. Most of these metrics are not listed on the manufacturer's datasheets.

Solar array comparison can be challenging because SmallSat/CubeSat manufacturers who make solar arrays specific to their bus and payload designs often do not report solar array power using the same metrics. Their reported "power" can mean multiple things: power available to the payload, peak power provided by a combination of solar array and battery, or an orbital-specific average power. Solar array power (Peak BOL) reported in the chart is mainly referring to the peak power of the solar array at the beginning of life, 28°C which is mission-independent. Panel stiffness and moment of inertia are dependent on multiple factors such as the size and mass of the panel as well as spacecraft size and weight distribution, and usually need to be calculated for a specific spacecraft. Examples of commercial solar array and panel products are shown in table 3-2.

Table 3-2: Solar Array/Panel Products						
Company	Product	Panel Type	Specific Power (W/kg)	Peak BOL Solar Array Power (W)	TRL	Ref
AAC Clyde Space	Photon	Body Mount + Deployed Rigid	*	9.25W / 3U-12 Face	7-9	(11)
Blue Canyon Technologies	BCT Solar Array	Body Mount + Deployed Rigid	*	28 – 42 (3U) / 48-118 (6U-12U)	7-9	(12)
DHV Technologies	Solar Panels for CubeSats Set	Body Mounted (Polyimide)	50	2 (1U) Face	9	(13)



Solar Panels for CubeSats Set	Body Mounted (Polyimide)	49	4 (2U) Face	9
Solar Panels for CubeSats Set	Body Mounted (Polyimide)	75	8 (3U) Face	9
Solar Panels for CubeSats Set	Body Mounted (Polyimide)	68	18 (6U) Face	9
Solar Panels for CubeSats Set	Deployed Rigid (Polyimide)	42	12 (3U) Double Deployable and Body Mounted	9
Solar Panels for CubeSats Set	Deployed Rigid (Polyimide)	69	57 (6/12U) Double Deployable and Body Mounted	9
Solar Panels for CubeSats Set	Deployed Rigid (Polyimide)	108	34 (3U) Quadruple Deployable	8
Solar Panels for CubeSats Set	Deployed Rigid (CFRP)	69	68 (6U) Quadruple Deployable	6
Solar Panels for CubeSats Set	Body Mounted (Polyimide)	50	2 (1U) Face	9
Solar Panels for CubeSats Set	Body Mounted (Polyimide)	49	4 (2U) Face	9
Body mounted solar array panel	Sandwich CFRP substrate	84	179	9
Body mounted solar array panel	Sandwich CFRP substrate	90	171	9
Body mounted solar array panel	Low thickness monolithic CFRP substrate	140	96	8
Multiple deployable solar array wing	Sandwich CFRP substrate	57	697	8



Exoterra	Fold Out Solar Arrays (FOSA)	Deployed Flexible	140	150	5-6	(14)
MMA Design	Hawk	Deployed Rigid (PCB)	121	36-112	7-9	(15)
	zHawk	Deployed Rigid (PCB)	95	36	7-9	(16)
Airbus Defense and Space Netherlands	Sparkwing Solar Panel	Deployed Rigid	165	66	5-6	(17)
Agencia Espacial Civil Ecuatoriana	DSA/1A	Deployed Rigid	107	7.2	7-9	(18)
GomSpace	Nanopower DSP	Deployed Rigid	*	1.2	7-9	(19)
ISISPACE	Smallsat Solar Panels	Body Mount + Deployed Rigid	46	2.3W / U	7-9	(20)
Redwire Space	ROSA	Flexible PV blanket	100	1000	5**	(21)
	Aladdin SmallSat Array	Hybrid Array: Flex Rigid	80	300	5-6	
EnduroSat	1U Solar Panel	Deployed Rigid	50	2.4	7-9	(35)
	1.5U Solar Panel	Deployed Rigid	55	2.4	7-9	
	3U Solar Panel/Array	Deployed Rigid	66	8.4	5-6	
	6U Solar Panel/Array	Deployed Rigid	64	19.2	5-6	
Nanoavionics	CubeSat GaAs Solar Panel	Deployed Rigid	Unk	Unk	7-9	(89)

\* Available with inquiry to manufacturer

\*\* For SmallSat use

### 3.3 On the Horizon – Power Generation

New technologies continue to be developed for space-qualified power generation. Promising technologies applicable to small spacecraft include advanced multi-junction, flexible and organic solar cells, hydrogen fuel cells, and a variety of thermo-nuclear and atomic battery power sources.



### 3.3.1 Multi-junction Solar Cells

Fraunhofer Institute for Solar Energy Systems has developed different four-junction solar cell architectures that currently reach up to 38% efficiency under laboratory conditions, although some designs have only been analyzed in terrestrial applications and have not yet been optimized (Lackner). Fraunhofer ISE and EV have achieved 33.3% efficiency for a 0.002 mm thin silicon-based multi-junction solar cell, and future investigations are needed to solve current challenges of the complex inner structure of the sub-cells (22). Additionally, SpectroLab has been experimenting with 5- and 6-junction cells with a theoretical efficiency as high as 70% (23).

A collaboration between the Air Force Research Laboratory (AFRL) and SolAero has developed Metamorphic Multi-Junction (IMM- $\alpha$ ) solar cells that are less costly with increased power efficiency for military space applications (1). The process for developing IMM- $\alpha$  cells involves growing them upside down, where reversing the growth substrate and the semiconductor materials allow the materials to bond to the mechanical handle, resulting in the more effective use of the solar spectrum (1). A single cell can leverage up to 32% of captured sunlight into available energy. This also results in a lighter, more flexible product. These cells had their first successful orbit in low-Earth orbit in 2018, and since then they have operated in low-Earth orbit on other CubeSat missions.

### 3.3.2 Flexible Solar Cells

Flexible and thin-film solar cells have an extremely thin layer of photovoltaic material placed on a substrate of glass or plastic. Traditional photovoltaic layers are around 350 microns thick, while thin-film solar cells use layers just one micron thick. This allows the cells to be flexible, lightweight, and cheaper to manufacture because they use less raw material. The performance of commercial flexible CIGS was investigated and reported with the potential for deep space applications at the University of Oklahoma. The authors found promising thin-film solar material using Cu(In, Ga)Se<sub>2</sub> (CIGS) solar cells with recorded power conversion efficiencies up to 22.7% (24).

### 3.3.3 Organic Solar Cells

Another on the horizon photovoltaic technology uses organic or “plastic” solar cells. These use organic electronics or organic polymers and molecules that absorb light and create a corresponding charge. A small quantity of these materials can absorb a large amount of light making them cheap, flexible, and lightweight.

Toyobo Co., Ltd. and the French government research institute CEA have succeeded in making trial organic photovoltaic (OPV) small cells on a glass substrate. Trial OPV modules on a lightweight and thin polyethylene terephthalate (PET) film substrate were demonstrated during their joint research project. Toyobo and CEA succeeded in making the OPV small cells on a glass substrate with the world’s top-level conversion efficiency by optimizing the solvents and coating technique. In a verification experiment under neon lighting with 220 lux, equivalent to the brightness of a dark room, the trial product was confirmed to have attained a conversion efficiency of about 25%, or 60% higher than that of amorphous silicon solar cells commonly used for desktop calculators (25).

In October 2016, the Optical Sensors based on carbon materials (OSCAR) stratospheric-balloon flight test demonstrated organic-based solar cells for the first time in a stratospheric environment. While more analysis is needed for terrestrial or space applications, it was concluded that organic solar energy has the potential to disrupt “conventional” photovoltaic technology (26). Since then, a joint collaborative agreement between the German Aerospace Center and the Swedish National Space Board REXUS/BEXUS has made the balloon payload available for European university student experiments collaborating with the European Space Agency (ESA) (27).





No standardized stability tests are yet available for organic-based solar cell technology, and challenges remain in creating simultaneous environmental influences that would permit an in-depth understanding of organic photovoltaic behavior, but these achievements are enabling progress in organic-based solar cell use. In 2018, Chinese researchers in organic photovoltaics were able to reach 17% power conversion energy using a tandem cell strategy. This method uses different layers of material that can absorb different wavelengths of sunlight, which enables the cells to use more of the sunlight spectrum, which has limited the performance of organic cells (28).

### 3.3.4 Fuel Cells

Hydrogen fuel cells are appealing due to their small, light, and reliable qualities, and high energy conversion efficiency. They also allow missions to launch with a safe, storable, low-pressure, and non-toxic fuel source. An experimental fuel cell from the University of Illinois that is based on hydrogen peroxide rather than water has demonstrated an energy density of over  $1000 \text{ Wh kg}^{-1}$  with a theoretical limit of over  $2580 \text{ Wh kg}^{-1}$  (29). This makes them more appealing for interplanetary missions and during eclipse periods, however unlike chemical cells, they cannot be recharged on orbit. Carrying a large fuel tank is not feasible for small or nanosatellite missions. Regenerative fuel cells are currently being researched for spacecraft applications. Today, fuel cells are primarily being proposed for small spacecraft propulsion systems rather than for power sub-systems (30).

## 3.4 State-of-the-Art – Energy Storage

Solar energy is not always available during spacecraft operations; the orbit, mission duration, distance from the Sun, or peak loads may necessitate stored, onboard energy. Primary and secondary batteries are used for power storage and are classified according to their different electrochemistry. As primary-type batteries are not rechargeable, they are typically used for short mission durations. Silver-zinc is typically used as they are easier to handle and discharge at a higher rate, however, there are also a variety of lithium-based primary batteries that have a higher energy density, including lithium Sulfur dioxide ( $\text{LiSO}_2$ ), lithium carbon monofluoride ( $\text{LiCF}_x$ ) and lithium thionyl chloride ( $\text{LiSOCl}_2$ ) (36).

Secondary-type batteries include nickel-cadmium ( $\text{NiCd}$ ), nickel-hydrogen ( $\text{NiH}_2$ ), lithium polymer ( $\text{LiPo}$ ) and lithium-ion ( $\text{Li-ion}$ ), which have been used extensively in the past on small spacecraft. Lithium-based secondary batteries are commonly used in portable electronic devices because of their rechargeability, low weight, and high energy, and have become ubiquitous on spacecraft missions. They are generally connected to a primary energy source (e.g., a solar array) and can provide rechargeable power-on-demand. Each battery type is associated with certain applications that depend on performance parameters, including energy density, cycle life, and reliability (36). Figure 3.3 shows some popular 18650 Lithium-Ion cells and their specific energy densities. While legacy cells had a specific energy of less  $200 \text{ Wh/kg}$ , latest cells have all exceeded  $240 \text{ Wh/kg}$ . Traditionally, vendors pack these 18650 cells in various configurations to meet customer needs. Table 3-3 shows a list of battery pack assemblers with their products and TRLs.

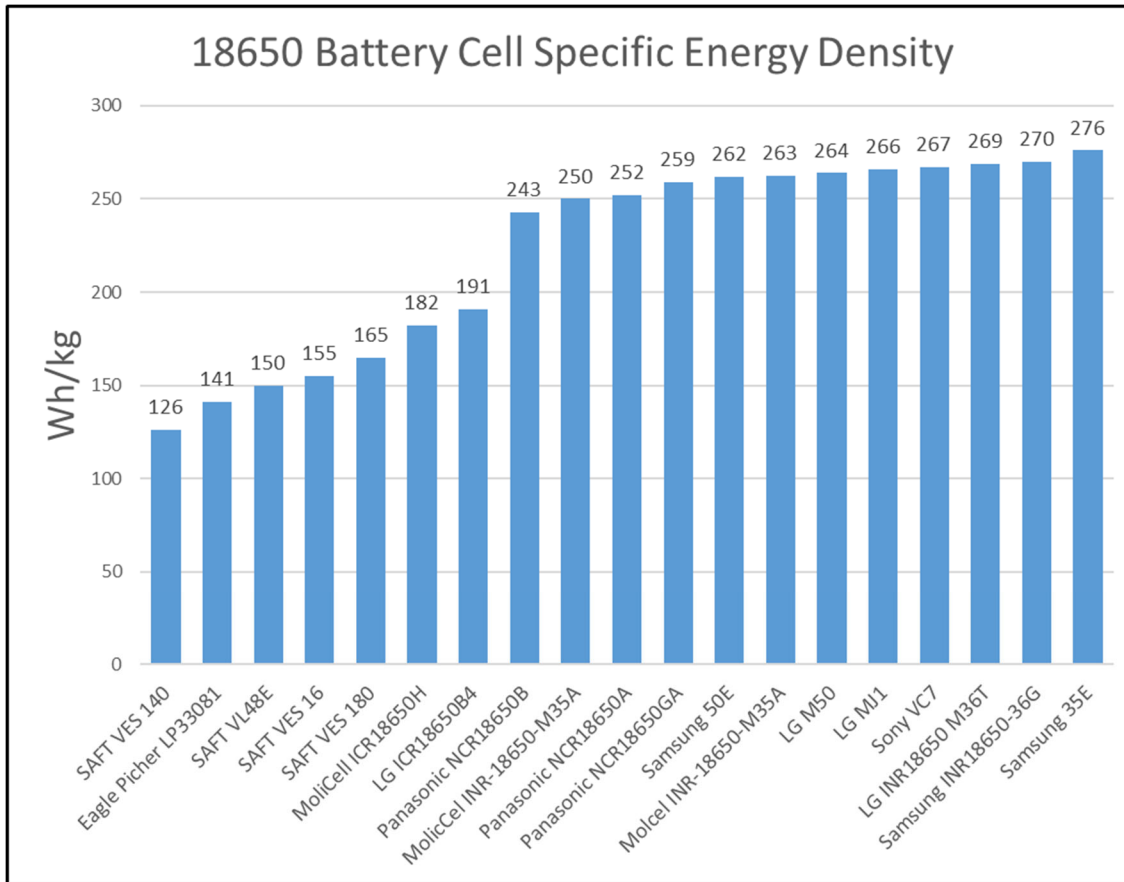


Figure 3.3: Battery cell energy density. Credit: NASA.

This section will discuss the individual chemical cells as well as pre-assembled batteries of multiple connected cells offered from multiple manufacturers. Due to small spacecraft mass and volume requirements, the batteries and cells in this section will be arranged according to specific energy, or energy per unit mass. However, several other factors are worth considering, some of which will be discussed below (37).

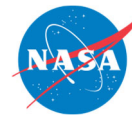


Table 3-3: Battery (Pack) Product Table								
Company	Product	Volumetric Energy Density [Wh L <sup>-1</sup> ]	Specific Energy [Wh kg <sup>-1</sup> ]	Typical Capacity [Ah]	Max Discharge Rate [A]	Cells Used	TRL	Ref
EaglePicher Technologies	NPD-002271	271	153.5	14.5	15	EaglePicher Li-ion	7-9	(39)
GomSpace	Nanopower BPX (4S-2P)	228.7	150	5.2	2.5	GomSpace NanoPower Li-ion	7-9	(42)
GomSpace	Nanopower BP4 (2S-2P)	211.9	149.2	5.2	2.5	GomSpace NanoPower Li-ion	7-9	(43)
AAC Clyde Space	Optimus	169.5	119	4.84	2.6	Clyde Space Li-Polymer	7-9	(44)
Ibeos	28V Modular Battery	151.1	109.8	9.82	20	*	N/A	(45)
Saft	VES16 4S1P	109.2	91	4.5	4.5 – Cont. 9 - Pulse	SAFT Li-ion	7-9	(46)
Vectronic Aerospace GmbH	VLB-X	101.96	74.6	12	10 – Cont. 20 - Pulse	SAFT Li-Ion	7-9	(47)
Berlin Space Technologies	BAT-110 Modular Battery (Nominal 3 strings)	69.73	57.75	7.5	3	Li-Fe	7-9	(48)
GUMUSH AeroSpace	n-ART BAT	184.5	155.1	6.01	8	Li-Ion	7-9	

\* Available with Inquiry to Manufacturer



The chemistry and cell design impacts the volumetric and specific energy densities. This limit represents the total amount of energy available per unit volume or weight, respectively. Current top-of-the-line Li-ion energy cells exhibit  $\sim 270 \text{ Wh kg}^{-1}$ . Li-ion batteries exhibit lower energy densities due to the inclusion of a battery management system (BMS), interconnects, and sometimes thermal regulation.

There are generally two groups of cells – high energy or high power. High power cells use a low resistance design, such as increasing coating surface area, or multiple points of contact for the current collector to the cell which can allow for lower overall resistance values and a higher rate of discharge. High energy cells work to optimize gravimetric energy densities to obtain the most energy from the cell. Some common methods to increase gravimetric energy densities are via the addition of silicon to the anode, the use of high voltage cathodes, or using a metallic lithium anode. However, these methods can significantly reduce the cyclability of the battery system in exchange for increased energy density.

In general, for space applications, high energy density is important because a battery with high gravimetric energy density will be cheaper to launch into orbit (higher battery capacity per unit mass). However, for some high pulse applications, high-power cells would meet mission needs with less weight. However, energy density is not the only factor to investigate during cell selection. For non-space commercial applications, faster degradation (lower cyclability) of the battery can be beneficial as the electronic device often lasts as long as the battery, and faster turnover of a device may lead to increased revenue.

While space-designed cells typically underperform in energy density, they over-perform in cyclability with many space-designed cells used for longer ( $\sim 5$ -15 year) missions. Of a limited number of COTS cells tested, NASA results for 40% low-Earth orbit testing showed that the LG MJ1 provides the best cyclability compared to some of its peers for 1500 cycles (61). However, not all degradation modes for the lithium-ion trend in a linear fashion, and trends often take time to settle, thus the test results don't necessarily show the best performing cell until others are further along in testing.

Due to the extremely short mission durations with primary cells, the current state-of-the-art energy storage systems use lithium-ion (Li-ion) or lithium-polymer (LiPo) secondary cells, so this subsection will focus only on these electrochemical compositions, with some exceptions.

### **3.4.1 Secondary Li-ion and Lipo Batteries**

Typically, Li-ion cells deliver an average voltage of 3.6 V, while the highest specific energy obtained is well over  $150 \text{ Wh kg}^{-1}$  (37). Unlike electronics, battery cells do not typically show significant damage or capacity losses due to radiation. However, in an experiment done by JPL, some capacity loss is seen among these latest lithium-ion battery cells under a high dosage of Cobalt-60. The results are shown below in figure 3.4 (62).

In Lithium-ion batteries, repeated charging cycles of the battery eventually result in aging or degradation that affects the overall energy (Watt-hours) that the battery may provide. Many variables impact aging, such as temperature, charge/discharge rate, depth of discharge, storage conditions, etc. Due to the numerous variables that impact aging, lithium-ion batteries are typically put under life test in mission conditions before launch to ensure the battery will meet the specific mission life requirements.

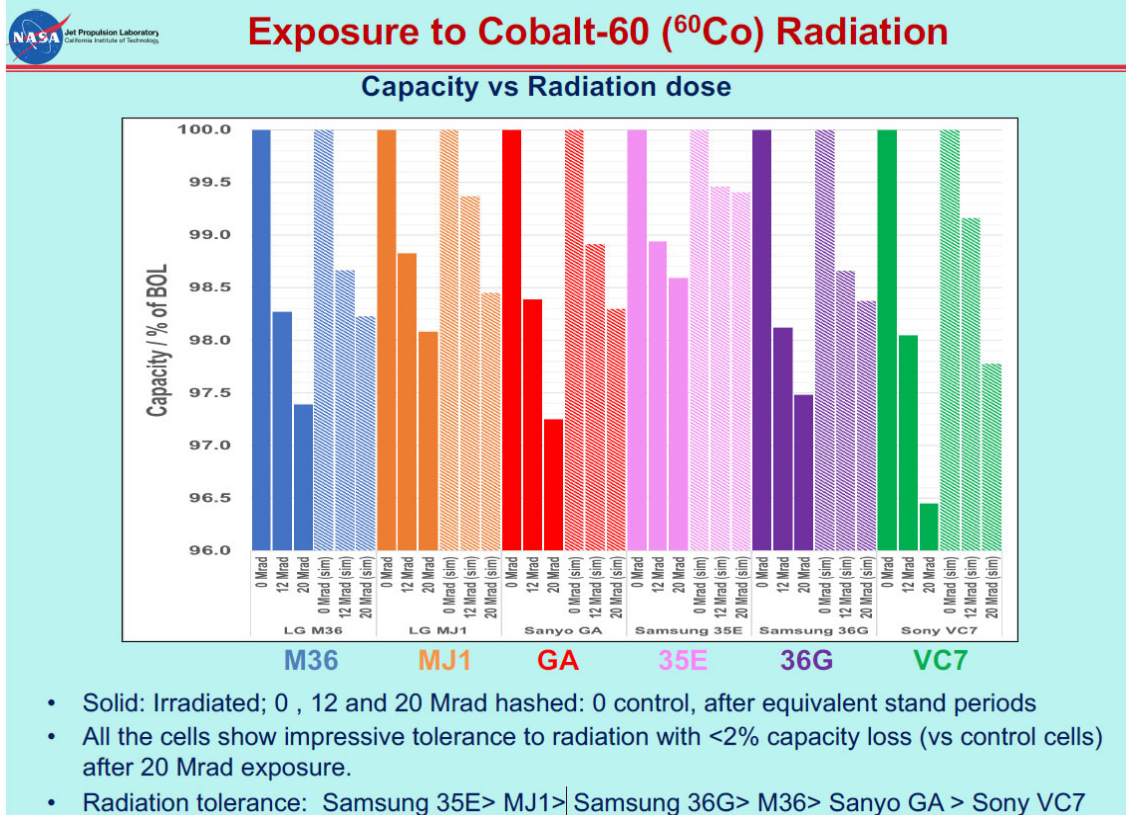
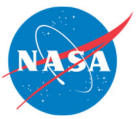


Figure 3.4: Capacity vs. radiation dose. Credit: JPL.

18650 Cells

18650 cylindrical cells (18 x 65 mm) have been an industry standard for lithium-ion battery cells. Many manufacturers have staple high-performance 18650 cells, some of which have flown on multiple spacecraft and are documented in table 3-4 below.

Table 3-4: 18650 Cylindrical Cells		
Cell	Specific Energy (Wh kg <sup>-1</sup> )	Flight Heritage
LG ICR18650 B3 (2600 mAh)	191	NASA's PhoneSat, NoDES
Panasonic NCR18650B (3350 mAh)	243	MarCO, ADAPT (Sept 2022*: BioSentinel, Lunar Flashlight, NeaScout)
Molicel ICR18650H (2200 mAh)	182	NASA's EDSN mission
Canon BP-930s (3000 mAh)	112	NASA's TechEdSat missions
LG MJ1 (3500 mAh)	260	NASA's PACE mission

Cylindrical 18650s have become the most commonly used building blocks for many SmallSats today, although prismatic and pouch formats are also available. The lithium-ion industry has seen incremental increases in energy density via the inclusion of silicon in the anode, high voltage cathodes, new electrolyte additives, and improved cell designs.

### 21700 Cells

21700 (21 x 70 mm) is another type of cylindrical cell that is getting more popular in the automotive industry. Samsung 50E and LG M50 both offer 5000 mAh of energy while the Samsung cells are slightly heavier. The specific energy densities are 262 Wh kg<sup>-1</sup> and 264 Wh kg<sup>-1</sup> respectively. Although 21700 cells are slightly larger than 18650 cells, they have some of the highest energy densities and could offer some mechanical packaging benefits with fewer cells for certain missions. Figure 3.5 shows various 21700 battery cell specific densities.

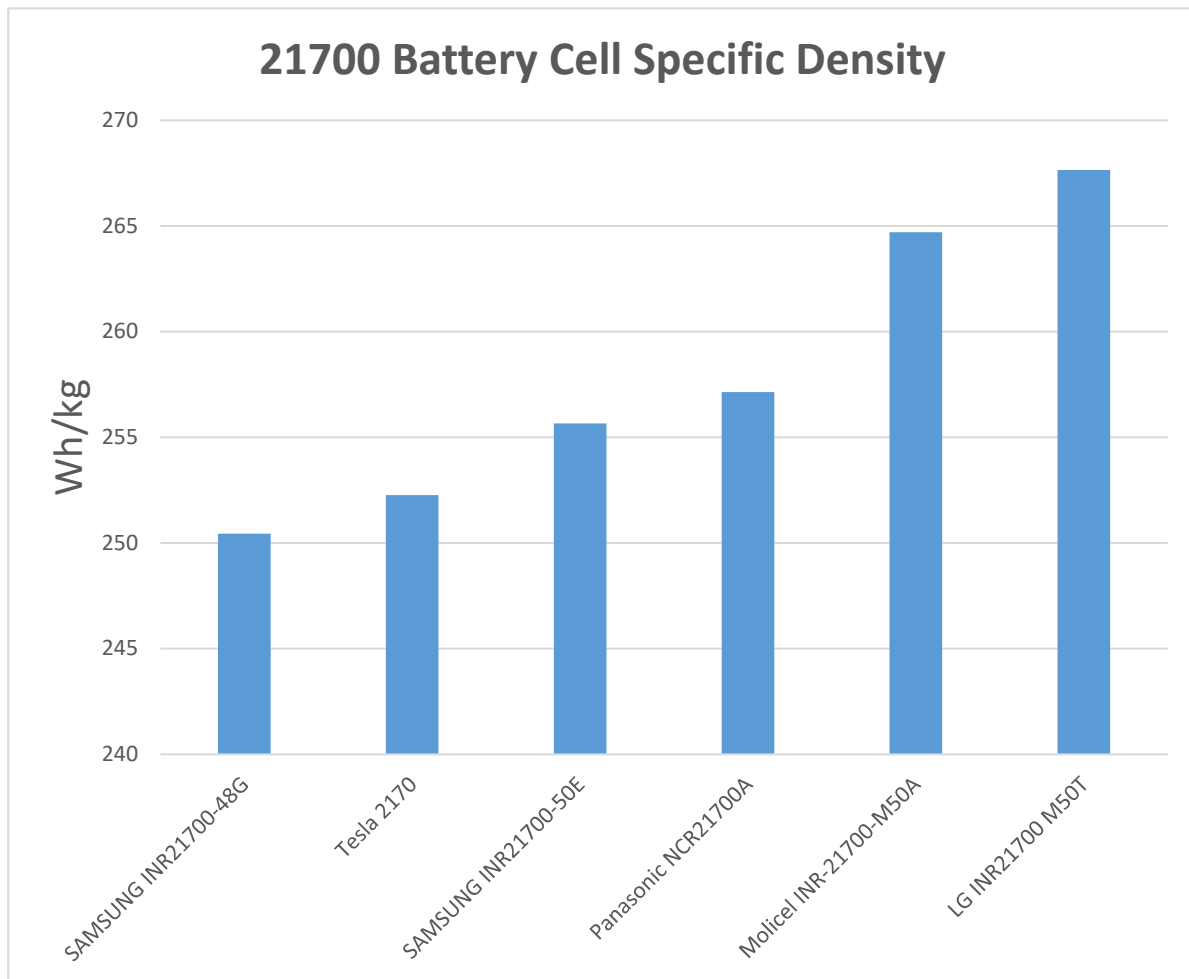


Figure 3.5: 21700 Battery Cell Specific Density. Credit: NASA.

### 4680 Cells

4680 (46 x 80 mm) cylindrical cells are a battery cell form factor that has been introduced to the energy storage scene by Tesla. The larger format cell potentially exacerbates several of the thermal management drawbacks (particularly internal temperature gradients and heterogeneity in current distribution) associated with other common smaller cells, however, to address these drawbacks, Tesla has a “tabless current collection” method where the current collector foil is used



in conjunction with an array of current collectors to reduce ohmic losses and the temperature increases that those losses can cause (63).

When it comes to the manufacturing of Li-ion batteries and battery cells, these companies are at the forefront for their respective sectors listed in table 3-5. Although China has some of the largest consumer electronics and EV battery manufacturers, their products are rarely used in the space industry which requires high performance and high reliability. Therefore, we do not include these products in this report at this time.

<b>Table 3-5: Commercial and Space Li-ion Manufacturers</b>			
<b>Commercial Li-ion Manufacturing</b>		<b>Space Li-ion Manufacturing</b>	
<b>Company</b>	<b>Headquarters</b>	<b>Company</b>	<b>Headquarters</b>
Panasonic	Japan	EaglePicher Technologies	USA
LG Chem	South Korea	Enersys	USA
Samsung	South Korea	GS Yuasa	Japan
E-one Moli	Taiwan	Saft	France
Sony	Japan	Tesla	USA

### 3.5 On the Horizon – Energy Storage

In the area of power storage, there are several ongoing efforts to improve storage capability and relative power and energy densities; a Ragone Chart shown in figure 3.6 illustrates different energy devices (64). For example, the Rochester Institute of Technology and NASA Glenn Research Center (GRC) developed a nano-enabled power system on a CubeSat platform. The power system integrates carbon nanotubes into lithium-ion batteries that significantly increase available energy density. The energy density has exceeded  $300 \text{ Wh kg}^{-1}$  during testing, a roughly two-fold increase from the current state of the art. The results in this program were augmented from a separate high-altitude balloon launch in July 2018 organized through NASA GRC which showed typical charge and discharge behavior on the ascent up to an altitude of 19 km (65). A collaborative project between the University of Miami and NASA Kennedy Space Center (KSC) is aiming to develop a multifunctional structural battery system that uses an electrolytic carbon fiber material that acts as both a load-bearing structure and a battery system. This novel battery system will extend mission life, support larger payloads, and significantly reduce mass. While several panel prototypes have shown successively increased electrochemical performance, further testing of the individual components can improve the accuracy of the computational models (66).

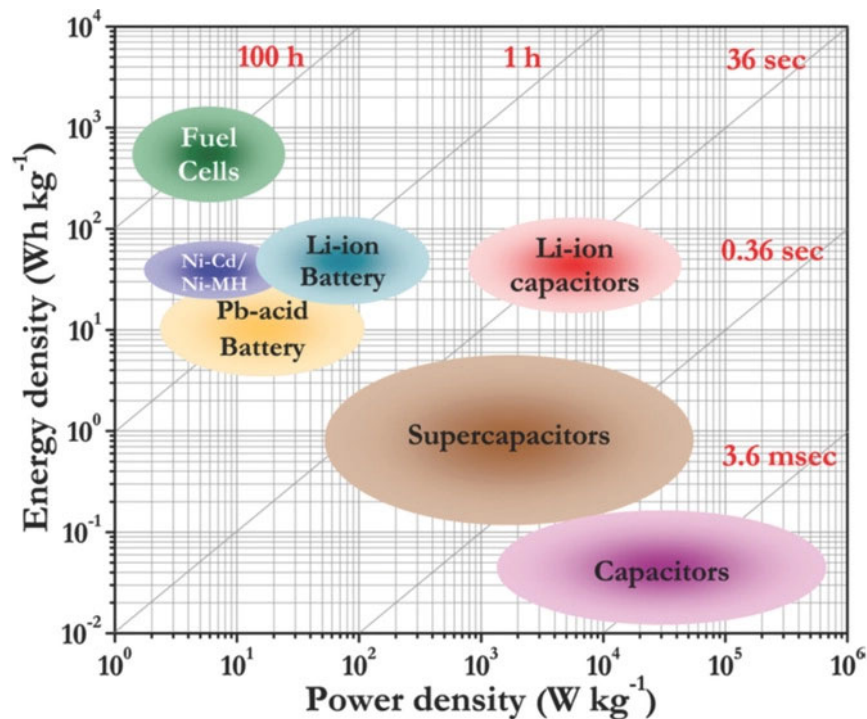


Figure 3.6 Relative power and energy densities of different energy devices. Ragone chart illustration reprinted with permission from Aravindan et al. Copyright (2014) American Chemical Society.

### 3.5.1 Supercapacitors

While the energy density for supercapacitors, also called ultracapacitors, is low (up to 7 Wh kg<sup>-1</sup>), they offer a very high-power density (up to 100 kW kg<sup>-1</sup>) which could be useful for space applications that require power transients. Their fast charge and discharge time, their ability to withstand millions of charge/discharge cycles, and wide range of operational temperatures (-40°C to +70°C), make them a perfect candidate for several space applications (launchers and satellites). This was demonstrated in an ESA Study entitled “High Power Battery Supercapacitor Study” completed in 2010 by Airbus D&S (67). The Nesscap 10F component and a bank of supercapacitors based on the Nesscap 10F component were space-qualified in 2020 after the completion of the ESA Study entitled “Generic Space Qualification of 10F Nesscap Supercapacitors.” Although not likely to replace Li-ion batteries completely, supercapacitors could drastically minimize the need for a battery and help reduce weight while improving performance in some applications. Figure 3.7 shows a comparison chart (68), and table 3-6 lists differences in Li-ion batteries and supercapacitors (69).



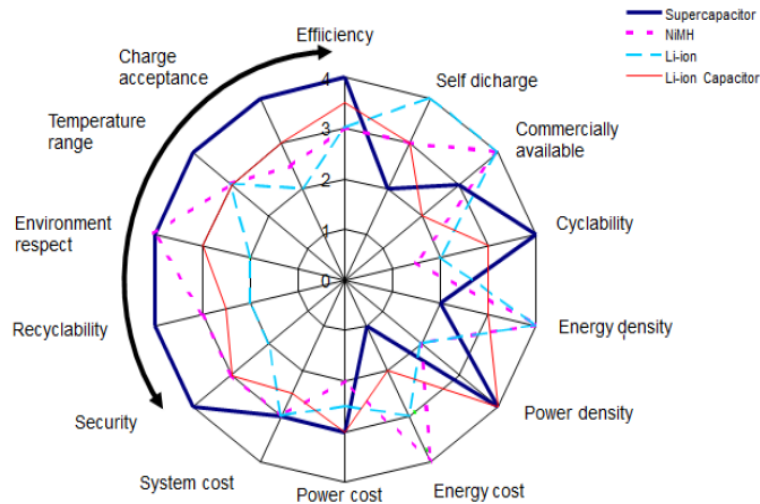


Figure 3.7: Supercapacitor comparison chart. Credit: Airbus Defense and Space and ESA (2016).

Table 3-6: Battery-vs-Supercapacitor Specifications		
Feature	Li-Ion Battery	Supercapacitor
Gravimetric energy (Wh kg <sup>-1</sup> )	100 – 265	4 – 10
Volumetric energy (Wh L <sup>-1</sup> )	220 – 400	4 – 14
Power density (W kg <sup>-1</sup> )	1,500	3,000 – 40,000
Voltage of a cell (V)	3.6	2.7 – 3
ESR (mΩ)	500	40 - 300
Efficiency (%)	75 – 90	98
Cyclability (nb charges)	500 – 1,000	500,000 – 20, 000,000
Life (years)	5 – 10	10 – 15
Self-discharge (% per month)	2	40 – 50 (descending)
Charge temperature	0 to 45°C	-40 to 65°C
Discharge temperature	-20C~60°C	-40 to 65°C
Deep discharge pb	yes	no
Overload pb	yes	no



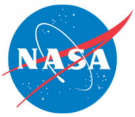
Risk of explosion	yes	no
Charging 1 cell	complex	easy
Charging cells in series	complex	complex
Voltage on discharge	stable	decreasing
cost (\$) per kW h	235 – 1,179	11,792

The lithium-ion capacitor is a promising recent development in the world of energy storage, combining the energy storage capabilities of both lithium-ion batteries as well as double-layered capacitors; they provide a middle ground between power density and energy density, but suffer from limited life-cycles. Some lithium-ion capacitors have minimum specific energy of 200 Wh kg<sup>-1</sup> but are limited by a maximum specific power of <350 W kg<sup>-1</sup> (88).

### 3.5.2 Solid-State Batteries

A majority of the batteries being used in contemporary space applications are lithium-ion batteries that use liquid electrolytes, however, these batteries carry an inherent risk of combustion from physical damage as well as thermal runaway due to overcharge. As a result, spacecraft often carry parasitic weight in the form of cooling systems and housing units. Interest in battery designs that solve the issue of safety and improve on energy and power density has been an industry topic for a long time, ultimately leading the way to NASA's Solid-state Architecture Batteries for Enhanced Rechargeability and Safety (SABER) project, which aims to create solid-state batteries that have significantly higher energy than the current state-of-the-art lithium-ion batteries and do not catch fire or lose capacity over time. Current strides in this project include examination and testing on unique battery chemistries including sulfur-selenium and "holey graphene" (70). See table 3-7 for examples of solid-state batteries.

<b>Manufacturer</b>	<b>Product</b>	<b>Wh/kg</b>	<b>Wh/L</b>
Solid Power	Silicon EV Cell	390	930
Solid Power	Lithium Metal	440	930
Solid Power	Conversion Reaction Cell	560	785
QuantumScape	LFP (projected)	230	600
QuantumScape	NMC (projected)	300	1000



### 3.5.3 Batteries for Low-Temperature Applications

Typical Li-Ion batteries have an operating temperature range of -20°C to 60°C (3). This may not meet the requirements for missions what require lower operating temperature. See table 3-8 for batteries with low-temperature applications.

<b>Company/Chemistry</b>	<b>Package</b>	<b>Temperature</b>	<b>Specific Energy</b>
EEMB/Li-Ion (93)	Custom	-40°C ~ 60°C	193.5 (Wh kg <sup>-1</sup> )
Tadiran/LiSOCl <sub>2</sub>	Custom	-80°C ~ 125°C -40°C ~ 85°C	1420 Wh/l 1420 Wh/l
GREPOW/LiPo	Custom/Pouch	-40°C ~ 60°C -55°C ~ 50°C	N/A
GREPOW/Li-Ion (LiFePO <sub>4</sub> )	Custom/Pouch	-40°C ~ 50°C	N/A

### 3.6 State-of-the-Art – Power Management and Distribution

Power management and distribution (PMAD) systems control the flow of power to spacecraft subsystems and instruments and are often custom-designed by mission engineers for specific spacecraft power requirements, however, several manufacturers have begun to provide a variety of PMAD devices for inclusion in small spacecraft missions. PMAD not only delivers power coming from energy sources (typically solar arrays in SmallSat applications) but also conditions energy as well, mitigating harmful transient disturbances and fault conditions from propagating downstream and hurting connected loads.

Several manufacturers supply EPS which typically have a main battery bus voltage of 8.2 V but can distribute a regulated 5.0 V and 3.3 V to various subsystems. The EPS also protects the electronics and batteries from off-nominal current and voltage conditions. As the community settles on standard bus voltages, PMAD standardization may follow. Well-known producers of PMAD systems that focus on the small spacecraft market include Pumpkin, GomSpace, Stras Space, and AAC Clyde Space. However, several new producers have begun to enter the PMAD market with a variety of products, some of which are listed below. Table 3-9 lists PMAD system manufacturers; it should be noted that this list is not exhaustive.

Key considerations in determining PMAD device selection often include conversion efficiency, input/output voltage range, output power capabilities, and size, weight, and power (SWaP). These metrics are critical to consider for good SmallSat PMAD designs, but it is important to note that PMAD devices are best chosen to suit the exact application of the SmallSat mission. SmallSat missions are often short and more flexible in terms of risk management than larger satellites, and therefore lend themselves to greater flexibility in design choices. One must leverage the benefits and risks to the mission at hand when choosing COTS PMAD systems, which may include the following:

- COTS PMAD may require less intensive integration and testing but have drawbacks to be addressed in a custom PMAD build



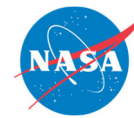
- Unnecessary features and peripherals (e.g., excess switching, fusing, current capability) can greatly increase SWaP metrics on a SmallSat
- Variability in designs of COTS PMAD devices means that important features and protections are not available in all devices (MPPT, Dead-bus protections, redundancy mechanisms, etc.)

Due to the variability of COTS PMAD options, many choice considerations, from internal power management topologies/materials to telemetry and protection options, are either included or omitted from products depending on the manufacturer. Internal power regulation topologies have traditionally been silicon-based, but relatively recent research into the performance improvements of Gallium Nitride (GaN) topologies has increased the number of GaN-based PMAD options in the consumer market with the following benefits over their silicon counterparts:

- Ability to achieve high switching rates and lower switching losses, allowing for the downsizing of inductors and capacitors, and improving SWaP metrics
- Lack of gate oxide layer in GaN-based field-effect transistors yields improvements in overall efficiency

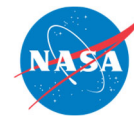
It must also be noted that GaN-based PMAD options are not to be considered as drop-in replacements for silicon-based PMAD options, as despite the number of performance improvements, GaN architectures come with a variety of drawbacks including high complexity of control circuitry and lack of flight heritage.

In looking at the table below, one must note that there is no single COTS PMAD solution that can fit all needs of a mission at hand. In appealing to a broad range of applications, most COTS PMAD devices make sacrifices that can impact important metrics for SmallSats, including SWaP as well as the efficiency and quality of the power being managed. In choosing to use COTS PMAD devices, designers and system architects should be aware of, and try to minimize, unnecessary features not beneficial to the mission.

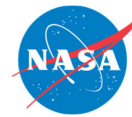


**Table 3-9: Power Management and Distribution System Products**

Company	Product	Mass (kg)	Volume (cm <sup>3</sup> )	Peak Power Output (W)	Input Voltages (VDC)	Output Voltages (VDC)	Max Efficiency (%)	TRL	Ref
Pumpkin	EPSM 1	0.300	180	300	4-32	3.3-28	99.0	9	(71)
AAC Clyde Space	Starbuck Micro	2.45	3968	120	28	28 / 5	97	9	(72)
	Starbuck Mini	5.90	13133	1200	*	22-34 / 5 / 8/ 12 / 15	*	9	(73)
	Starbuck Nano	0.086	140	*	*	3.3 / 5/ 12	*	9	(74)
GomSpace	P31U	0.100	127	30	0-8	3.3 / 5	96	9	(75)
ISISPACE	iEPS Type C	0.360	14.13	13	12.8-16	3.3 / 5 / Unreg	95	9	(76)
DHV	MicroEPS	0.285-1.135 (+0.170 for optional radiation shielding case)	392-1045	592 in eclipse/ 693 in sunlight	10-40 (X/Y) / 9-28 Z	3.3 / 5/ 12 / Batt	93	5	
DHV	NanoEPS	0.155-0.402 (+0.109 for	283-600	59 in eclipse/ 124 in sunlight	9-28 (X/Y) / 3-18 (Z)	3.3 / 5/ 12 / Batt	93	9	

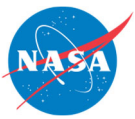


		option al radiati on shieldi ng case)							
DHV	PicoEPS	0.110- 0.190 (+0.1 for option al radiati on shieldi ng case)	140-197	29 in eclipse/ 74 in sunlight	3-18	3.3 / 5/ 12 / Batt	93	8	
EnduroSat	EPS I	0.208	183	10-20	0-5.5	3.3 / 5 / Batt	86	9	(79)
	EPS I Plus	0.292	259	30	0-5.5	3.3 / 5 / Batt	86	9	(80)
	EPS II	1.280	742	250	10-36	3.3 / 5 / 6-12 / Batt	89	9	(81)
Ecarver GmbH	PCU-SB7	1.500	1800	250	0-24	0-24	85	N/A	(82)
Berlin Space Technologies	PCU-110	0.960	1191	*	20-25	3.3 / 5/ 12 / 24 / 1.8-28	*	9	(83)



Ibeos	150W CubeSat EPS	0.140	124	150	18-42	3.3 / 5 / 12 / Unreg Batt	95	8	(84)
Ibeos	200W, 28V CubeSat EPS	0.14	124	200	12-34	3.3 / 5 / 12 / Unreg Batt	96	8	
Ibeos	Modular EPS (500W – 2,000W)	Starting at <1	Starting at 1150	500 – 2,000	12-26	5 / 12 / Unreg Batt	98	6	
Nanoavionics	CubeSat EPS	*	*	175	2.6-18	3.3 / 5 / 3-18	96	N/A	(85)
GUMUSH AeroSpace	n-ART EPS	0.098	160	100 W	4.5-30	3.3 / 5 / 8-36 / Batt	94	6	
Spacemanic	AMUN_PSU	0.2 kg	173	70W	~8V	3.3V	80	9	
Argotec	PCDU VOLTA	0.97	600	100	18-22	1x 3.3V, 1x 5V and 2x 12V	75	9	
C3S Electronics Development LLC	EPS	~0.860	~731	90 W	6...25V 6ch SA	3.3V, 5V, 9.9...12.3V	90%	9	

\* Available with inquiry to manufacturer



### **3.7 On the Horizon – Power Management and Distribution**

Power management and distribution have been steadily improving each year due to changes in technology, as well as from different approaches to maximizing the use of these systems, including modular architectures, wireless telemetry, and power transmission options.

#### **3.7.1 Modular Architecture**

For small spacecraft, traditional EPS architecture is centralized (each subsystem is connected to a single circuit board). This approach provides simplicity, volume efficiency, and inexpensive component cost. However, a centralized EPS is rarely reused for a new mission, as most of the subsystems need to be altered based on new mission requirements. A modular, scalable EPS for small spacecraft was detailed by Timothy Lim and colleagues, where the distributed power system is separated into three modules: solar, battery, and payload. This allows scalability and reusability from the distributed bus, which provides the required energy to the (interfaced) subsystem (86).

ISISPACE has a modular EPS for CubeSat missions (3U+) that includes a large amount of flexibility in output bus options with adjustable redundancy for certain parts of the device. The modular EPS consists of a power conditioning unit for solar panel input, secondary power storage, a battery holder with an integrated fuse, and a power regulation and distribution unit for subsystem loads. Each unit is designed to be independent, allowing for daisy-chaining and flexibility in redundancy and subsystem upgrades. This device is based on heritage from the Piezoelectric Assisted Smart Satellite Structure (PEASSS) CubeSat flown in 2016, with the device itself successfully flown in 2018 (76).

#### **3.7.2 Wireless Power Transfer and Telemetry**

In the commercial world, the technology already exists for wireless sensing and power transmission from the order of microwatts, all the way up to kilowatts. In the realm of SmallSats, wireless power transfer/detection would be useful as redundant options in dusty environments where physical connectors can be contaminated, or in situations where hardware needs to be swapped around and powered (battery swaps). While wireless power transfer/detection is highly inefficient when compared to conventional means, research and development in this technology for use in space applications has a lot of potential in increasing the reliability and robustness of SmallSat power management and distribution.

### **3.8 Summary**

Driven by weight and mostly size limitations, small spacecraft are using advanced power generation and storage technology such as >32% efficient solar cells and lithium-ion batteries. The higher risk tolerance of the small spacecraft community has allowed both the early adoption of technologies like flat lithium-polymer cells, as well as COTS products not specifically designed for spaceflight. This can dramatically reduce cost and increase mission-design flexibility. In this way, power subsystems are benefiting from the current trend of miniaturization in the commercial electronics market as well as from improvements in photovoltaic and battery technology.

Despite these developments, the small spacecraft community has been unable to use other, more complex technologies. This is largely because the small spacecraft market is not yet large enough to encourage the research and development of technologies like miniaturized nuclear energy sources. Small spacecraft power subsystems would also benefit from greater availability of flexible, standardized power management and distribution systems so that every mission need not be designed from scratch. In short, today's power systems engineers are eagerly adopting certain innovative Earth-based technology (like lithium polymer batteries) while, at the same time,





patiently waiting for important heritage space technology (like fuel cells and RTGs) to be adapted and miniaturized. Despite the physical limitations and technical challenges these power generation technologies have, most small nanosatellites in the foreseeable future will still likely carry batteries to support the transient load.

For feedback solicitation, please email: [arc-sst-soa@mail.nasa.gov](mailto:arc-sst-soa@mail.nasa.gov). Please include a business email so someone may contact you further.

## References

- (1) M. Alia-Novobilski. "Advanced Multi-junction Solar Cells Deliver High Efficiency, Reduced Costs for Space." [Online] January 4, 2018. Accessed July 15, 2018. Available at: <https://phys.org/news/2018-01-advanced-multi-junction-solar-cells-high.html#jCp>
- (2) M.A. Green. "Third Generation Photovoltaics: Advanced Solar Energy Conversion." Springer. Vol. 12. 2003.
- (3) AzurSpace. "Space Products, Solar Cells." [Online] 2020. Accessed May 15, 2021. Available at: <http://www.azurspace.com/index.php/en/products/products-space/space-solar-cells>
- (4) EMCORE. "BTJ Space Solar Cells." Technical Datasheet. [Online] September 2021. Available at: <https://dtsheet.com/doc/1248164/btj-photovoltaic-cell>
- (5) SpectroLab. "XTE-SF (Standard Fluence) Space Qualified Triple Junction Solar Cell." Datasheet. [Online] May 16, 2020. Accessed: May 16, 2021. Available at: <https://www.spectrolab.com/photovoltaics/XTE-SF%20Data%20Sheet%2012.23.19.pdf>
- (6) SpectroLab. "30.7% Triple Junction Space Grade Solar Cell." Datasheet. [Online] 2018. Accessed July 15, 2018. Available at: [https://www.spectrolab.com/DataSheets/cells/XTJ\\_Prime\\_Data\\_Sheet\\_7-28-2016.pdf](https://www.spectrolab.com/DataSheets/cells/XTJ_Prime_Data_Sheet_7-28-2016.pdf).
- (7) SpectroLab. "Ultra-Triple Junction (UTJ) Cells". Datasheet. [Online] 2018. Accessed: July 16, 2021. Available at; <http://www.spectrolab.com/DataSheets/cells/2015%20UTJ%20CIC%20Datsheet.pdf>
- (8) SpectroLab. "Triangular Advanced Solar Cells (TASC)." Datasheet. [Online] Accessed July 16, 2021. Available at: [https://www.spectrolab.com/DataSheets/PV/PV\\_NM\\_TASC\\_ITJ.pdf](https://www.spectrolab.com/DataSheets/PV/PV_NM_TASC_ITJ.pdf)
- (9) SpectroLab. "26.8% Improved Triple Junction (ITJ) Solar Cells." Datasheet. [Online] Accessed July 16, 2021. Available at: <https://www.spectrolab.com/DataSheets/TNJCell/tnj.pdf>
- (10) SolAero. "Space Solar Cells/CICs." [Online]. 2020. Accessed: June 30, 2021. Available at: <https://solaerotech.com/space-solar-cells-cics/>
- (11) AAC Clyde Space. "Photon." Datasheet. [Online]. Accessed July 17, 2021. Available at: [https://www.aac-clyde.space/assets/000/000/078/PHOTON\\_original.pdf?1564954830](https://www.aac-clyde.space/assets/000/000/078/PHOTON_original.pdf?1564954830)
- (12) Blue Canyon Technologies. "Power Systems." Datasheet. [Online] Accessed: July 19, 2021. Available at: [https://www.bluecanyontech.com/static/datasheet/BCT\\_DataSheet\\_Components\\_Power\\_Systems.pdf](https://www.bluecanyontech.com/static/datasheet/BCT_DataSheet_Components_Power_Systems.pdf)
- (13) DHV Technology. "Products - Solar Panels for CubeSats." [Online] 2020. Available at: <https://dhvtechnology.com/products>



- (14) Exoterra. Fold Out Solar Arrays (FOSA) Datasheet [Online]. Available at: <https://exoterracorp.com/products/power/>
- (15) MMA Design. "Space Power Solutions." [Online] Available at: <https://mmadesignllc.com/products/solar-arrays/>
- (16) MMA\_Design. rHaWK Solar Array. [Online] May 16, 2020. Accessed May 16, 2020. Available at: <https://mmadesignllc.com/product/r-hawk-solar-array/>.
- (17) Airbus Defense and Space Netherlands: Datasheet, "Sparkwing: The plug and play solution in power your small satellite." [Online] Accessed: July 16, 2021. Available at: <https://sparkwing.space/>
- (18) Agencia Espacial Civil Ecuatoriana. Datasheet, "DSA: 1U Deployable Solar Arrays." [Online] Accessed: July 18, 2021. Available at: <https://satsearch.co/products/exa-1u-deployable-solar-panels-dsa-1a>
- (19) GomSpace Datasheet, "Nanopower Deployable Solar Panel for 3U or 6U satellite." [Online] Accessed: July 18, 2021. Available at: [https://gomspace.com/UserFiles/Subsystems/datasheet/GS-DS-NanoPower\\_DSP\\_1018088\\_25.pdf](https://gomspace.com/UserFiles/Subsystems/datasheet/GS-DS-NanoPower_DSP_1018088_25.pdf)
- (20) Innovative Solutions in Space: "Small satellite solar panels." 2021. [Online] Accessed: July 18, 2021. Available at: <https://www.isispace.nl/product/isis-cubesat-solar-panels/>
- (21) Redwire Space. "Redwire's Innovative Solar Array Technology Powering the Future of Space Exploration." [Online] May 25, 2021. Accessed: July 18, 2021. Available at: <https://redwirespace.com/2021/05/25/redwires-innovative-solar-array-technology-powering-the-future-of-space-exploration/>
- (22) Seeger, Daniel. "Fraunhofer ISE Announces 33% Efficiency for Multi-junction Solar Cell." [Online] 2018. <https://www.pv-magazine.com/2018/04/04/fraunhofer-ise-announces-33-efficiency-for-multi-junction-solar-cell/>
- (23) King, R. "Raising the Efficiency Ceiling in Multijunction Solar Cells." Stanford Photonics Research Center Symposium, 2009. 2015.
- (24) C. Brown et al. "An Investigation of Flexible Cu(In,Ga)Se<sub>2</sub> Solar Cells Under Low Intensity Low Temperature for Potential Applications for Outer Planetary Missions." IEEE Journal of Photovoltaics. 2019.
- (25) Toyobo Co., Ltd. "Toyobo to practicalize power-generating material for organic photovoltaics with world's top-level conversion efficiency under room light." May 23, 2020.
- (26) L. Cardinaletti et al. "Organic and Perovskite Solar Cells for Space Applications." Solar Energy Materials and Solar Cells, p. 182. 2018.
- (27) S. Nagels. "OSCAR: the First Hasselt University Aerospace Project." 2020.
- (28) L. Meng et al. "Organic and Solution-processed Tandem Solar Cells with 17.3% efficiency." 6407, Vol. 361. 2018.
- (29) N. Luo et al. "Hydrogen-Peroxide-Based Fuel Cells for Space Power Systems." Vol. 24, no. 3. 2008.
- (30) Ethier, V, et al. "Development of a CubeSat Water-Electrolysis Propulsion System." 2013.



- (31) ~~“Radioisotope Power Systems (RPS) Program.” National Aeronautics and Space Administration. 2015.~~
- (32) ~~Light Weight Radioisotope Heater Unit | Thermal Systems . (n.d.). NASA RPS: Radioisotope Power Systems, from <https://rps.nasa.gov/power-and-thermal-systems/thermal-systems/light-weight-radioisotope-heater-unit/>~~
- (33) ~~Joannopoulos, Aristeidis Karalis and J. D.. “Squeezing’ near field thermal emission for ultra-efficient high-power thermophotovoltaic conversion.” 2016.~~
- (34) ~~Nighttime Photovoltaic Cells: Electrical Power Generation by Optically Coupling with Deep Space. Tristan Deppe and Jeremy N. Munday. ACS Photonics 2020 7 (1), 1-9. DOI: 10.1021/acsp Photonics.9b00679~~
- (35) EnduroSat. CubeSat 3U Solar Panel X/Y MTQ. [Online] 2017. Available at: <https://www.endurosat.com/products/cubesat-3u-solar-panel-x-y-mtq/>
- (36) R.A Nelson. "Spacecraft Battery Technology." VIA SATELLITE, pp. 104 - 118, February 1999.
- (37) Jung, D. S. and Manzo, M. A.. "NASA Aerospace Flight Battery Program." NASA/TM-2010-216728/Vol I. 2010.
- (38) Eagle Pitcher. LP34100 Datasheet [Online] Available at: <https://www.eaglepitcher.com/sites/default/files/LP34100%205Ah%20021820.pdf>
- (39) EaglePitcher Technologies. “Lithium-Ion Space Battery.” Data Sheet Catalog\_Part2\_Part5. Page 21
- (40) EaglePitcher Technologies. LP33330 Datasheet [Online] Available at: <https://www.eaglepitcher.com/sites/default/files/LP%2033330%206Ah%20Space%20Cell%200319.pdf>
- (41) EaglePitcher Technologies. LP32975 Datasheet [Online] Available at: <https://www.eaglepitcher.com/sites/default/files/LP%2032975%2012%20Ah%20Space%20Cell%20%20040219.pdf>
- (42) GomSpace. Datasheet, “NanoPower BPX.” [Online]. Accessed: July 19, 2021. Available at: <https://gomspace.com/shop/subsystems/power/nanopower-bpx.aspx>
- (43) GomSpace. Datasheet, “NanoPower BP4.” [Online]. Accessed: July 19, 2021. Available at: <https://gomspace.com/shop/subsystems/power/nanopower-bp4.aspx>
- (44) AAC Clyde Space. Datasheet, “Optimus Battery.” July 28. 2020.
- (45) Ibeos. Cubesat Product Overview. [Online] 2020. Accessed: July 16, 2021. Available at: <https://ibeos.com/products.html>.
- (46) Saft. 4s1p VES16 Battery [Online]. 2019. Available at: <https://www.saftbatteries.com/products-solutions/products/4s1p-ves16-battery>
- (47) Vectronic Aerospace. Li-Ion Battery Block VLB-4/ -8 /-16. 2014.[Online] Accessed July 18, 2021. Available at: <https://satsearch.co/products/vectronic-aerospace-li-ion-battery-block-vlb-4-8-16>
- (48) Berlin Space Technologies. “Battery BAT 110,” Technical Datasheet, [Online] Available at: <https://www.berlin-space-tech.com/portfolio/battery-bat-110/>



- (49) Samsung. INR18650-35E Datasheet [Online]. Accessed: July 18, 2021. Available at: <https://www.orbtronic.com/content/samsung-35e-datasheet-inr18650-35e.pdf>
- (50) Sony: Murata. US18650VC7 Battery Datasheet [Online]. Accessed: July 18, 2021. Available at: [https://www.batterypacks.com/content/sony\\_us18650vc7.pdf](https://www.batterypacks.com/content/sony_us18650vc7.pdf)
- (51) Panasonic. NCR18650B Datasheet [Online] Available at: <https://www.orbtronic.com/content/NCR18650B-Datasheet-Panasonic-Specifications.pdf>
- (52) Panasonic. NCR18650A Datasheet [Online] Available at: [https://www.orbtronic.com/product\\_images/uploaded\\_images/panasonic-ncr18650a-datasheet-specs-sanyo-18650-battery-specifications.png](https://www.orbtronic.com/product_images/uploaded_images/panasonic-ncr18650a-datasheet-specs-sanyo-18650-battery-specifications.png)
- (53) LG Chem. "Product Specification: Rechargeable Lithium Ion Battery Model ICR18650 B3 2600mAh." 2007
- (54) Molicel. ICR18650M Rechargeable Battery [Online] Available at: <https://www.custompower.com/documents/ICR18650M.pdf>
- (55) Molicel. IHR18650C Datasheet [Online] Available at: [http://www.molicel.com/wp-content/uploads/DM\\_IHR18650C-V4-80073.pdf](http://www.molicel.com/wp-content/uploads/DM_IHR18650C-V4-80073.pdf)
- (56) Molicel. ICR18650H Datasheet [Online] Available at: <https://www.custompower.com/documents/ICR18650H.pdf>
- (57) Molicel. ICR18650J Datasheet [Online] Available at: <https://www.custompower.com/documents/ICR18650J.pdf>
- (58) Molicel. ICP103450DA Datasheet [Online]. Available at: <https://www.custompower.com/documents/ICP103450DAProductDataSheetF.pdf>
- (59) Molicel. INR18650A Datasheet [Online] Available at: [http://www.molicel.com/wp-content/uploads/DM\\_INR18650A-V4-80078.pdf](http://www.molicel.com/wp-content/uploads/DM_INR18650A-V4-80078.pdf)
- ~~(60) Molicel. Panasonic Lithium Ion NCR18650B. 2012.~~
- (61) A. Zimmerman and E. Jung. "Verification Sciences & Engineering Case Study of Counterfeit COTS Li-ion Cells." 2019. NASA Aerospace Battery workshop.
- (62) JPL. "NASA Battery Workshop." [Online] November 19, 2019. Accessed May 16, 2020. Available at: [https://www.nasa.gov/sites/default/files/atoms/files/3-nasa\\_battery\\_workshop\\_nov\\_2019\\_high\\_power\\_li-ion\\_cells\\_final.pdf](https://www.nasa.gov/sites/default/files/atoms/files/3-nasa_battery_workshop_nov_2019_high_power_li-ion_cells_final.pdf)
- (63) T. G. Tranter et al. "Communication—Prediction of Thermal Issues for Larger Format 4680 Cylindrical Cells and Their Mitigation with Enhanced Current Collection." 2020 J. Electrochem. Soc. 167 160544
- (64) Aravindan, V., Gnanaraj, J., Lee, Y., & Madhavi, S. (2014). Insertion-type electrodes for nonaqueous Li-ion capacitors. Chemical reviews, 114 23, 11619-35.
- (65) R. Raffaele. "Demonstration of a Nano-Enabled Space." [Online] 2018. Available at: <https://ntrs.nasa.gov/archive/nasa/casi.ntrs.nasa.gov/20170011060.pdf>
- (66) R.L. Karkkainen. "Development of Lightweight CubeSat with Multi-Functional Structural Battery Systems." [Online] 2018. Available at: <https://ntrs.nasa.gov/archive/nasa/casi.ntrs.nasa.gov/20170011078.pdf>



- (67) B. Faure, L. Cosqueric, and V. Gineste. "Evaluation and Qualification of Commercial Off-The-Shelf Supercapacitors for Space." 2nd Space Passive Component Days (SPCD) International Symposium. Noordwijk, The Netherlands: s.n., 2016.
- (68) SupercapTech. SupercapTech. [Online] May 21, 2016. Accessed: June 1, 2020. Available at: <https://www.supercaptech.com/battery-vs-supercapacitor>
- (69) POWERBOX. "The Silent Power of Supercapacitors." White paper 017. 2019.
- (70) Gipson, L. "NASA Seeks to Create a Better Battery with SABERS." [Online] April 7, 2021. Available at: <https://www.nasa.gov/feature/nasa-seeks-to-create-a-better-battery-with-sabers/>
- (71) Pumpkin, Inc. CubeSat Kit Electrical Power System 1 (EPS1). [Online] 2018. Available at: [https://www.pumpkinspace.com/store/p216/High-power\\_Multi-channel\\_Electrical\\_Power\\_System\\_Module\\_%28EPSM1%29.html](https://www.pumpkinspace.com/store/p216/High-power_Multi-channel_Electrical_Power_System_Module_%28EPSM1%29.html)
- (72) AAC Clyde Space. Starbuck Micro Original Datasheet. [Online] 2020. Available at: [https://www.aac-clyde.space/wp-content/uploads/2021/11/AAC\\_DataSheet\\_Starbuck-Micro.pdf](https://www.aac-clyde.space/wp-content/uploads/2021/11/AAC_DataSheet_Starbuck-Micro.pdf)
- (73) AAC Clyde Space. Starbuck Mini Original Datasheet. [Online] 2020. Available at: [https://www.aac-clyde.space/wp-content/uploads/2021/11/AAC\\_DataSheet\\_Starbuck-Mini-updated.pdf](https://www.aac-clyde.space/wp-content/uploads/2021/11/AAC_DataSheet_Starbuck-Mini-updated.pdf)
- (74) AAC Clyde Space. Starbuck Nano Original Datasheet. [Online] 2020. Available at: [https://www.aac-clyde.space/wp-content/uploads/2021/11/AAC\\_DataSheet\\_Starbuck-Nano.pdf](https://www.aac-clyde.space/wp-content/uploads/2021/11/AAC_DataSheet_Starbuck-Nano.pdf)
- (75) GomSpace. NanoPower P31u. [Online] 2018. Accessed: July 16, 2021. Available at: <https://gomspace.com/Shop/subsystems/power-supplies/nanopower-p31u.aspx>
- (76) Innovative Solutions in Space. IEPS Electrical Power System. [Online] 2020. Available at: <https://www.ISISPACE.nl/product/ieps-electrical-power-system/>
- (77) DHV Technology. "Electrical Power Systems." [Online] Available at: <https://dhvtechnology.com/products/electrical-power-systems/>
- (78) Extreme Engineering Solutions: "XPm2020." [Online] 2021. Accessed: July 20, 2021. Available at: <https://www.xes-inc.com/products/end-of-life-power-supplies/xpm2020/>
- (79) EnduroSat. EPS I. [Online] Available at: <https://www.endurosat.com/cubesat-store/cubesat-power-modules/eps-power-module/>
- (80) EnduroSat. EPS I Plus. [Online] Available at: <https://www.endurosat.com/cubesat-store/cubesat-power-modules/eps-power-module-i-plus/>
- (81) EnduroSat. EPS II + Battery Pack. [Online] Available at: <https://www.endurosat.com/cubesat-store/cubesat-power-modules/eps-power-module-ii/>
- (82) Ecarver GmbH: "Battery BP3-SN." [Online] Accessed: July 18, 2021. Available at: <https://satellite-power-systems.de/products.html>
- (83) Berlin Space Technologies. "Power Control Unit PCU-110." [Online]. Accessed: July 19, 2021. <https://www.berlin-space-tech.com/portfolio/powercontrolunit-pcu-110/>
- (84) Ibeos. Datasheet, "150-Watt SmallSat Electric Power Subsystem (EPS)." [Online] 2019. Available at": <https://www.ibeos.com/150w-eps-datasheet>



- (85) NanoAvionics. "CubeSat Electrical Power System EPS". [Online] 2017. Accessed: July 15, 2018. Available at: <https://n-avionics.com/cubesat-components/solar-panels-and-power-systems/cubesat-electrical-power-system-eps/>
- (86) T.M. Lim et al. "A Modular Electrical Power System." IEEE Transactions on Aerospace and Electronic Systems, Volume: 54, Issue: 4, August 2018.
- (87) Canon. BP-930 Material Safety Data Sheet. [Online] 2011. Available at: [https://files.canon-europe.com/files/webcontent/safety-data-sheets/EU\\_BP-Series-Batteries/bp-930\\_pdf.pdf](https://files.canon-europe.com/files/webcontent/safety-data-sheets/EU_BP-Series-Batteries/bp-930_pdf.pdf)
- (88) M. Soltani and S. H. Beheshti. "A comprehensive review of lithium -ion capacitor: development, modelling, thermal management and applications," Journal of Energy Storage, Volume 34, 2021.
- (89) Nanoavionics. "CubeSat GaAs Solar Panel." [Online] 2020. Accessed: May 16, 2020. Available at: <https://nanoavionics.com/cubesat-components/cubesat-gaas-solar-panel/>
- (90) NASA. 2020 Mission Perseverance Rover: Power Source." [Online] 2020. Accessed: September 27, 2021. Available at: <https://mars.nasa.gov/mars2020/spacecraft/rover/electrical-power/>
- (91) A.J. Colozza and R.L Cataldo. "Low Power Radioisotope Conversion Technology and Performance Summary". NASA/TM—2018-219940.
- (92) E. Peretz et al. "The Importance of Solar Power Technology Adaptations to Space Exploration", IEEE 2022 (In preparation)
- (93) EEMB Battery. Military Grade Li-ion Battery [Online] Accessed 2022. Available at: <https://www.eemb.com/low-temperature-version.html>



## Chapter Contents

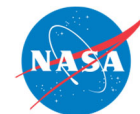
Chapter Glossary .....	ii
4.0 In-Space Propulsion .....	56
4.1 Introduction .....	56
4.1.1 Document Organization .....	57
4.2 Public Data Sources and Disclaimers .....	57
4.3 Definitions .....	58
4.4 Technology Maturity .....	58
4.4.1 Application of the TRL Scale to Small Spacecraft Propulsion Systems .....	58
4.4.2 Progress Toward Mission Infusion (PMI) .....	59
4.5 Overview of In-Space Propulsion Technology Types .....	62
4.6 State-of-the-Art in Small Spacecraft Propulsion .....	64
4.6.1 In-Space Chemical Propulsion .....	64
4.6.2 In-Space Electric Propulsion .....	77
4.6.3 In-Space Propellant-less Propulsion .....	97
References .....	111



## Chapter Glossary

(ABS)	Acrylonitrile Butadiene Styrene
(AC)	Alternating Current
(ACE)	Apollo Constellation Engine
(ACO)	Announcement for Collaborative Opportunity
(ADN)	Ammonium Dinitramide
(AFRL)	Air Force Research Laboratory
(AOCS)	Attitude and Orbit Control System
(AR)	Aerojet Rocketdyne
(ARC)	Ames Research Center
(CMNT)	Colloid MicroNewton Thrusters
(CNAPS)	Canadian Nanosatellite Advanced Propulsion System
(CNES)	French National Center for Space Studies
(CPOD)	CubeSat Proximity Operations Demonstration
(CUA)	CU Aerospace LLC
(DFMR)	Design for Minimum Risk
(DRM)	Design Reference Mission
(DSSP)	Digital Solid State Propulsion LLC
(EMC)	Electromagnetic Compatibility
(EMI)	Electromagnetic Interference
(EP)	Electric Propulsion
(EPSS)	Enabling Propulsion System for Small Satellites
(ESA)	European Space Agency
(ESPs)	Electrically Controlled Solid Propellant
(FASTSAT)	Fast, Affordable, Science and Technology Satellite
(FEPP)	Field Emission Electric Propulsion
(FPPT)	Fiber-Fed Pulsed Plasma Thruster
(GEO)	Geostationary Equatorial Orbit
(GIT)	Gridded-ion Thrusters
(GOCE)	Gravity Field and Steady-State Ocean Circulation Explorer
(GOX)	Gaseous Oxygen
(GPIM)	Green Propellant Infusion Mission
(GPS)	Global Positioning System





(GRC)	Glenn Research Center
(GSFC)	Goddard Space Flight Center
(HAN)	Hydroxylammonium Nitrate
(HET)	Hall-effect Thruster
(HTP)	High Test Peroxide
(HTPB)	Hydroxyl-terminated Polybutadiene
(IPS)	Integrated Propulsion System
(ISS)	International Space Station
(JHU ERG)	Johns Hopkins University Energetics Research Group
(JPL)	Jet Propulsion Laboratory
(LFPS)	Lunar Flashlight Propulsion System
(LISA)	Laser Interferometer Space Antenna
(MAPS)	Modular Architecture Propulsion System
(MarCO)	Mars Cube One
(MCD)	Micro-cavity Discharge
(MEMS)	Microelectromechanical System
(MEO)	Medium Earth Orbit
(MMH)	Monomethyl Hydrazine
(MPUC)	Monopropellant Propulsion Unit for CubeSats
(MSFC)	Marshall Space Flight Center
(MVP)	Monofilament Vaporization Propulsion
(N <sub>2</sub> O)	Nitrous Oxide
(NEA)	Near-Earth Asteroid
(NODIS)	NASA Online Directives Information System
(NSTT)	Nanosat Terminator Tape
(OTS)	Orbital Transfer System
(OTV)	Orbital Transfer Vehicle
(PacSci EMC)	Pacific Scientific Energetic Materials Company
(PBM)	Plasma Brake Module
(PMD)	Propellant Management Device
(PMDs)	Propellant Management Devices
(PMI)	Progress toward Mission Infusion
(PMMA)	Polymethyl Methacrylate
(PPT)	Pulsed Plasma Thrusters



(PPU)	Power Processing Unit
(PTD)	Pathfinder Technology Demonstration
(PTFE)	Polytetrafluoroethylene
(PUC)	Propulsion Unit for CubeSats
(ROMBUS)	Rapid Orbital Mobility Bus
(SAA)	Space Act Agreement
(SBIR)	Small Business Innovative Research
(SCAPE)	Self Contained Atmospheric Protective Ensemble
(SEP)	Solar Electric Propulsion
(SMAP)	Soil Moisture Active Passive
(SMART-1)	Small Missions for Advanced Research in Technology
(SME)	Subject Matter Experts
(SSTL)	Surrey Satellite Technology Ltd.
(SSTP)	Small Spacecraft Technologies Program
(TCMs)	Trajectory Correction Maneuvers
(TMA)	Technology Maturity Assessment
(TRL)	Technology Readiness Level
(UTIAS)	University of Toronto Institute for Aerospace Research
(VAT)	Vacuum arc thrusters
(VENuS)	Vegetation and Environment monitoring on a New Microsatellite
(WFF)	Wallops Flight Facility



## 4.0 In-Space Propulsion

### 4.1 Introduction

In-space propulsion devices for small spacecraft are rapidly increasing in number and variety. Although a mix of small spacecraft propulsion devices have established flight heritage, the market for new propulsion products continues to prove dynamic and evolving. In some instances, systems and components with past flight heritage are being reconsidered to meet the needs of smaller spacecraft. This approach minimizes new product development risk and time to market by creating devices similar to those with existing spaceflight heritage, although accounting for small spacecraft volume, mass, power, safety and cost considerations. Such incremental advancement benefits from existing spaceflight data, physics-based models, and customer acceptance of the heritage technologies, which eases mission infusion. In other instances, novel technologies are being conceived specifically for small spacecraft using innovative approaches to propulsion system design, manufacturing, and integration. While the development of novel technologies typically carries a higher risk and slower time to market, these new technologies strive to offer small spacecraft a level of propulsive capability not easily matched through the miniaturization of heritage technologies. Such novel devices are often highly integrated and optimized to minimize the use of a small spacecraft's limited resources, lower the product cost, and simplify integration. Regardless of the development approach, the extensive investments by commercial industry, academia, and government to develop new propulsion products for small spacecraft suggests long-term growth in the availability of propulsion devices with increasingly diverse capabilities.

In the near-term, the surge in public and private investments in small spacecraft propulsion technologies, combined with the immaturity of the overall small spacecraft market, has resulted in an abundance of confusing, unverified, sometimes conflicting, and otherwise incomplete technical literature. Furthermore, the rush by many device developers to secure market share has resulted in some confusion surrounding the true readiness of these devices for mission infusion. As third parties independently verify device performance, and end-users demonstrate these new devices in their target environments, the true maturity, capability, and flight readiness of these devices will become evident. In the meantime, this report will attempt to reduce confusion by compiling a list of publicly described small spacecraft propulsion devices, identifying publicly available technical literature for further consideration, recognizing missions of potential significance, and organizing the data to improve comprehension for both neophytes and subject matter experts.

This chapter avoids a direct technology maturity assessment (TMA) based on the NASA Technology Readiness Level (TRL) scale, recognizing insufficient in-depth technical insight into current propulsion devices to perform such an assessment accurately and uniformly. An accurate TRL assessment requires a high degree of technical knowledge on a subject device as well as an understanding of the intended spacecraft bus and target environment. While the authors strongly encourage a TMA that is well-supported with technical data prior to infusing technologies into programs, the authors believe TRLs are most accurately assessed within the context of a program's unique requirements. Rather than attempting to assess TRL in the absence of sufficient data, this chapter introduces a novel classification system that simply recognizes Progress toward Mission Infusion (PMI) as an early indicator of the efficacy of the manufacturers' approach to system maturation and mission infusion. PMI should not be confused with TRL as PMI does not directly assess technology maturity. However, PMI may prove insightful in early trade studies. The PMI classification system used herein is described in detail in Section 4.4.2.



### 4.1.1 Document Organization

This chapter organizes the state-of-the-art in small spacecraft propulsion into the following categories:

1. In-Space Chemical Propulsion (4.6.1)
2. In-Space Electric Propulsion (4.6.2)
3. In-Space Propellant-less Propulsion (4.6.3)

Each of these categories is further subdivided by the prevailing technology types. The subsections organize data on each prevailing technology type as follows:

- a. Technology Description
- b. Key Integration and Operational Considerations
- c. Current & Planned Missions
- d. Summary Table of Devices
- e. Notable Advancements

The organizational approach introduces newcomers to each technology, presents technology-specific integration and operation concerns for the reader's awareness, highlights recent or planned missions that may raise the TRL of specific devices, and finally tabulates procurable devices of each technology. Some sections further include an incomplete list of highlights of notable advancements. While the key integration and operational considerations are not all-inclusive, they provide initial insights that may influence propulsion system selection. In the cases where a device has significant flight heritage, this chapter reviews only select missions.

## 4.2 Public Data Sources and Disclaimers

This chapter is a survey of small spacecraft propulsion technologies as discussed in open literature and does not endeavor to be an original source. As such, this chapter only considers literature found in the public domain to identify and classify devices. Commonly used sources for public data include manufacturer datasheets, press releases, conference papers, journal papers, public filings with government agencies, and news articles.

This chapter summarizes device performance, capabilities, and flight history, as presented in publicly available literature. Data not appropriate for public dissemination, such as proprietary, export controlled, or otherwise restricted data, are not considered. As such, actual device maturity and flight history may be more or less extensive than what is documented herein. Device manufacturers should be consulted for the most up-to-date and relevant data before performing a TMA.

This chapter's primary data source is literature produced by device manufacturers. Unless otherwise published, do not assume independent verification of device performance and capabilities. Performance and capabilities described may be speculative or otherwise based on limited data.

The information presented is not intended to be exhaustive but to provide a general overview of current state-of-the-art technologies and their development status. It should be noted that technology maturity designations may vary with change to payload, mission requirements, reliability considerations, and/or the environment in which performance was demonstrated. Readers are highly encouraged to reach out to companies for further information regarding the performance and maturity of the described technology. There is no intention of mentioning certain companies and omitting others based on their technologies or relationship with NASA.



Suggestions or corrections to this document should be submitted to the NASA Small Spacecraft Virtual Institute [Agency-SmallSat-Institute@mail.nasa.gov](mailto:Agency-SmallSat-Institute@mail.nasa.gov) for consideration prior to the publication of future issues. When submitting comments, please cite appropriate publicly accessible references. Private correspondence is not considered an adequate reference.

### 4.3 Definitions

- *Device* refers to a component, subsystem, or system, depending on the context.
- *Technology* refers to a broad category of devices or intangible materials, such as processes.

### 4.4 Technology Maturity

#### 4.4.1 Application of the TRL Scale to Small Spacecraft Propulsion Systems

NASA has a well-established guideline for performing TMAs, described in detail in the NASA Systems Engineering Handbook (1). A TMA determines a device's technological maturity, which is usually communicated according to the NASA TRL scale. The TRL scale is defined in NASA Procedural Requirements (NPR) 7123 (2). The NASA Systems Engineering Handbook and NPR 7123 can be accessed through the NASA Online Directives Information System (NODIS) library. Assessment of TRLs for components, systems, or software allows for coherent communication between technologists, program managers, and other stakeholders regarding the maturity of a technology. Furthermore, TRL is a valuable tool to communicate the potential risk associated with the infusion of technologies into programs. For TRLs to be applied across all technology categories, the NASA TRL definitions are written broadly and rely on subject matter experts (SME) in each discipline to interpret appropriately.

Recently, U.S. Government propulsion SMEs suggested an interpretation of the TRL scale specifically for micro-propulsion. The Micro-Propulsion Panel of the JANNAF Spacecraft Propulsion Subcommittee in 2019 published the *JANNAF Guidelines for the Application of Technology Readiness Levels (TRLs) to Micro-Propulsion Systems* (3). This guideline suggests an interpretation of TRL for micro-propulsion and reflects both NASA and DOD definitions for TRL. The JANNAF panel consisted of participants from the Air Force Research Laboratory (AFRL), Glenn Research Center (GRC), Jet Propulsion Laboratory (JPL), and Goddard Space Flight Center (GSFC). The panel further received feedback from the non-Government propulsion community. While this JANNAF guideline focuses on micro-propulsion (e.g., CubeSats), the guideline still has relevance to rigorously assessing TRLs for the more general category of small spacecraft in-space propulsion. By establishing a common interpretation of TRL for small spacecraft propulsion, a more coherent and consistent communication of technology maturity can occur between small spacecraft propulsion providers and stakeholders. The JANNAF guideline is open to unlimited distribution and may be requested from the Johns Hopkins University Energetics Research Group (JHU ERG). Ensure the use of the latest JANNAF guideline, as the guideline is anticipated to evolve with further community input.

A fundamental limitation of the JANNAF guideline for TRL assessment, and TMA in general, is an assumption of in-depth technical knowledge of the subject device. In the absence of detailed technical knowledge, especially in a broad technology survey as presented herein, a TMA may be conducted inaccurately or inconsistently. Furthermore, assessment of TRL assumes an understanding of the end-user application. The same device may be concluded to be at different TRLs for infusion into different missions. For example, a device may be assessed at a high TRL for application to low-cost small spacecraft in low-Earth orbits, while assessed at a lower TRL for application to geosynchronous communication satellites or NASA interplanetary missions due to different mission requirements. Differences in TRL assessment based on the operating



environment may result from considerations such as thermal environment, mechanical loads, mission duration, or radiation exposure. Propulsion-specific variances between missions might include propellant type, total propellant throughput, throttle set-points, burn durations, and the total number of on/off cycles. As such, an accurate TRL assessment not only requires an in-depth technical understanding of a device's development history, including specifics on past flight-qualification activities, but also an understanding of mission-specific environments and interfaces. The challenge of assessing an accurate TRL in a broad technology survey poses a significant burden for data collection, organization, and presentation. Such activities are better suited for the programs seeking to infuse new technologies into their missions.

Given the rapid evolution of small spacecraft propulsion technologies and the variety of mission environments, as well as generally limited device technical details in open literature, the propulsion chapter implements a novel system to classify technical maturity according to Progress toward Mission Infusion (PMI). This novel classification system is not intended to replace TRL but is a complementary tool to provide initial insight into device maturity when it is not feasible to accurately and consistently apply the TRL scale. This novel classification system is discussed in detail below.

Readers are strongly encouraged to perform more in-depth technical research on candidate devices based on the most up-to-date information available, as well as to assess risk within the context of their specific mission(s). A thoughtful TMA based on the examination of detailed technical data through consultation with device manufactures can reduce program risk and increase the likelihood of program success. This survey is not intended to replace the readers' own due diligence. Rather, this survey and PMI seek to provide early insights that may assist in propulsion system down-select to a number of devices where an in-depth TMA becomes feasible.

#### **4.4.2 Progress Toward Mission Infusion (PMI)**

Rather than directly assessing a device's technical maturity via TRL, propulsion devices described herein are classified according to evidence of progress toward mission infusion. This is a novel classification system first introduced in this survey. Assessing the PMI of devices in a broad survey, where minimal technical insight is available, may assist with down-selecting propulsion devices early in mission development. Once a handful of devices are selected for further consideration, an in-depth technical examination of the selected devices may be more practical to conduct a TMA and rigorously assess TRL. The PMI classification system sorts devices into one of four broad technology development categories: Concept, In-Development, Engineering-to-Flight, and Flight-Demonstrated. The following sections describe the PMI classification system in detail. Furthermore, figure 4.1 summarizes the PMI classifications.

##### **Concept, 'C'**

The *Concept* classification reflects devices in an early stage of development, characterized by feasibility studies and the demonstration of fundamental physics. Concept devices typically align with the NASA TRL range of 1 to 3. At a minimum, these devices are established as scientifically feasible, perhaps through a review of relevant literature and/or analytical analysis. These devices may even include experimental verification that supports the validity of the underlying physics. These devices may even include notional designs. While Concept devices are generally not reviewed herein, particularly promising Concept devices will be classified in tables with a 'C'.

##### **In-Development, 'D'**

The *In-Development* classification reflects the bulk of devices being actively matured and covered in this survey, where only a modest number of devices may progress to regular spaceflight. In-



Development devices typically align with the NASA TRL range of 4 to 5. While In-Development devices may have specific applications attributed by their developers, no selection for a specific mission has been publicly announced. In the absence of a specific mission, device development activities typically lack rigorous system requirements and a process for independent requirement validation. Furthermore, qualification activities conducted in the absence of a specific mission typically require a delta-qualification to address mission-specific requirements. At a minimum, In-Development devices are low-fidelity devices that have been operated in an appropriate environment to demonstrate basic functionality and support prediction of the device's ultimate capabilities. They may even be medium- or high-fidelity devices operated in a simulated final environment, but lacking a specific mission pull to define requirements and a qualification program. They may even be medium- or high-fidelity devices operated in a spaceflight demonstration but lacking sufficient fidelity or demonstrated capability to reflect the anticipated final product. These devices are typically described as a technology push, rather than a mission pull. In-Development devices will be classified in tables with a 'D'.

### Engineering-to-Flight, 'E'

The *Engineering-to-Flight* classification reflects devices with a publicly announced spaceflight opportunity. This classification does not necessarily imply greater technical maturity than the In-Development classification, but it does assume the propulsion device developer is receiving mission-specific requirements to guide final development and qualification activities. Furthermore, the Engineering-to-Flight classification assumes a mission team performed due diligence in the selection of a propulsion device, and the mission team is performing regular activities to validate that the propulsion system requirements are met. Thus, while the PMI classification system does not directly assess technical maturity, there is an underlying assumption of independent validation of mission-specific requirements, where a mission team does directly consider technical maturity in the process of device selection and mission infusion. Engineering-to-Flight devices typically align with the NASA TRL range of 5 to 6. At a minimum, these are medium-fidelity devices that have been operated in a simulated final environment and demonstrate key capabilities relative to the requirements of a specific mission. These devices may even be actively undergoing or have completed a flight qualification program. These devices may even include a spaceflight, but in which key capabilities failed to be demonstrated or further engineering is required. These devices may even include a previously successful spaceflight, but the devices are now being applied in new environments or platforms that necessitate design modifications and/or delta-qualification. These devices must have a specific mission pull documented in open literature. A design reference mission (DRM) may be considered in place of a specific mission pull, given detailed documentation in open literature, which includes a description of the DRM, well-defined propulsion system requirements, maturation consistent with the DRM requirements, and evidence of future mission need consistent with the DRM. Engineering-to-Flight devices will be classified in tables with an 'E'.

### Flight-Demonstrated, 'F'

The *Flight-Demonstrated* classification reflects devices where a successful technology demonstration or genuine mission has been conducted and described in open literature. Flight-Demonstrated devices typically align with the NASA TRL range of 7 to 9. These devices are high-fidelity components or systems (in fit, form, and function) that have been operated in the target in-space environment (e.g., low-Earth orbit, GEO, deep space) on an appropriate platform, where all key capabilities were successfully demonstrated. These devices may even be final products, which have completed genuine missions (not simply flight demonstrations). These devices may even be in repeat production and routine use for several missions. The devices must be described



in open literature as successfully demonstrating key capabilities in the target environment to be considered Flight-Demonstrated. If a device has flown, but the outcome is not publicly known, the classification will remain Engineering-to-Flight. Flight-Demonstrated devices will be classified in tables with an 'F'.

<p><b>Concept, 'C'</b></p> <ul style="list-style-type: none"> <li>- At minimum, an idea has been established as scientifically feasible.</li> <li>- May even include experimental verification of the underlying physics.</li> <li>- May even include notional device designs.</li> <li>- Approximately aligns to NASA TRL 1-3</li> </ul>
<p><b>In-Development, 'D'</b></p> <ul style="list-style-type: none"> <li>- At minimum, a low-fidelity device that has been operated in an appropriate environment to demonstrate the basic functionality and predict the ultimate capabilities.</li> <li>- May even be a medium- or high-fidelity device operated in a simulated final environment, but the device lacks a specific mission pull to define requirements and a qualification program.</li> <li>- May even be a medium- or high-fidelity device operated in a flight demonstration, but the device lacks sufficient fidelity or demonstrated capability to reflect the anticipated final product.</li> <li>- Approximately aligns to NASA TRL 4-5</li> </ul>
<p><b>Engineering-to-Flight, 'E'</b></p> <ul style="list-style-type: none"> <li>- At minimum, a medium-fidelity device that has been operated in a simulated final environment and demonstrates key capabilities relative to the requirements of a specific mission.</li> <li>- May even include a qualification program in-progress or completed.</li> <li>- May even include a spaceflight, but the device fails to demonstrate key capabilities.</li> <li>- May even include a successful spaceflight, but the device is now being applied in a new environment or platform, necessitating a delta-qualification.</li> <li>- A specific mission opportunity must be identified in open literature.</li> <li>- Approximately aligns to NASA TRL 5-6</li> </ul>
<p><b>Flight-Demonstrated, 'F'</b></p> <ul style="list-style-type: none"> <li>- At minimum, a high-fidelity component or system (fit, form, and function) that has been operated in the intended in-space environment (e.g., LEO, GEO, deep space) on an appropriate platform, where key capabilities have been successfully demonstrated.</li> <li>- May even be a final product that has completed a mission (not strictly a technology demonstration).</li> <li>- May even be a product in repeat production and routine use for a number of missions.</li> <li>- A successful spaceflight must be identified and the outcome described in open literature.</li> <li>- Approximately aligns to NASA TRL 7-9</li> </ul>

Figure 4.1: Progress toward mission infusion (PMI) device classifications. Credit: NASA.





## 4.5 Overview of In-Space Propulsion Technology Types

In-space small spacecraft propulsion technologies are generally categorized as (i) chemical, (ii) electric, or (iii) propellant-less. This chapter surveys propulsion devices within each technology category. Additionally, liquid-propellant acquisition and management devices are reviewed as an important component of in-space propulsion systems. Although other key subsystems have not yet been reviewed, such as small spacecraft propulsion power processing units, they may be included in future updates of this publication. Table 4-1 lists the in-space propulsion technologies reviewed. Figure 4.2 graphically illustrates the range of thrust and specific impulse for these small spacecraft propulsion devices. The thrust and specific impulse ranges provided in table 4-1 and figure 4.1 only summarize the performance of small spacecraft devices covered in this survey and may not reflect the broader capability of the technologies beyond small spacecraft or the limits of what is physically possible with further technology advancement.

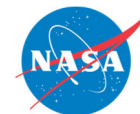
Chemical systems have enabled in-space maneuvering since the onset of the space age, proving highly capable and reliable. These include hydrazine-based systems, other mono- or bipropellant systems, hybrids, cold/warm gas systems, and solid propellants. Typically, these systems are sought when high thrust or rapid maneuvers are required. As such, chemical systems continue to be the in-space propulsion technology of choice when their total impulse capability is sufficient to meet mission requirements.

On the other hand, the application of electric propulsion devices has been historically far more limited. While electric propulsion can provide an order of magnitude greater total impulse than chemical systems, research and development costs have typically eclipsed that of comparable chemical systems. Furthermore, electric propulsion generally provides thrust-to-power levels below 75 mN/kW. Thus, a small spacecraft capable of delivering 500 W to an electric propulsion system may generate no more than 38 mN of thrust. Therefore, while the total impulse capability of electric propulsion is generally considerable, these systems may need to operate for hundreds or thousands of hours, compared to the seconds or minutes that chemical systems necessitate for a similar impulse. That said, the high total impulse and low thrust requirements of specific applications, such as station keeping, have maintained steady investment in electric propulsion over the decades. Only in recent years has the mission pull for electric propulsion reached a tipping point where electric propulsion may overtake chemical for specific in-space applications. Electric propulsion system types considered herein include electrothermal, electrospray, gridded ion, Hall-effect, pulsed plasma and vacuum arc, and ambipolar.

Propellant-less propulsion technologies such as solar sails, electrodynamic tethers, and aerodynamic drag devices have long been investigated, but they have yet to move beyond small-scale demonstrations. However, growing needs such as orbital debris removal may offer compelling applications in the near future.

Some notable categories are not covered in this survey, such as nuclear in-space propulsion technologies. While substantial investment continues in such areas for deep space science and human exploration, such technologies are generally at lower TRL and typically aim to propel spacecraft substantially larger than the 180 kg limit covered by this report.

Whenever possible, this survey considers complete propulsion systems, which are composed of thrusters, feed systems, pressurization systems, propellant management and storage, and power processing units, but not the electrical power supply. However, for some categories, components (e.g., thruster heads) are mentioned without consideration of the remaining subsystems necessary for their implementation. Depending on the device's intended platform (i.e., NanoSat, MicroSat, SmallSat), the propulsion system may be either highly integrated or distributed within



the spacecraft. As such, it is logical to describe highly integrated propulsion units at the system level, whereas components of distributed propulsion systems may be logically treated at the sub-system level, where components from a multitude of manufacturers may be mixed-and-matched to create a unique mission-appropriate propulsion solution.

<b>Table 4-1: Summary of Propulsion Technologies Surveyed</b>		
<b>Technology</b>	<b>Thrust Range</b>	<b>Specific Impulse Range [sec]</b>
<b>4.6.1 CHEMICAL PROPULSION TECHNOLOGIES</b>		
Hydrazine Monopropellant	0.25 – 25 N	200 – 285
Alternative Mono- and Bipropellants	10 mN – 120 N	160 – 310
Hybrids	1 – 230 N	215 – 300
Cold / Warm Gas	10 $\mu$ N – 3 N	30 – 110
Solid Motors	0.3 – 260 N	180 – 280
Propellant Management Devices	N/A	N/A
<b>4.6.2 ELECTRIC PROPULSION TECHNOLOGIES</b>		
Electrothermal	0.5 – 100 mN	50 – 185
Electrosprays	10 $\mu$ N – 1 mN	225 – 5,000
Gridded Ion	0.1 – 20 mN	1,000 – 3,500
Hall-Effect	1 – 60 mN	800 – 1,950
Pulsed Plasma and Vacuum Arc Thrusters	1 – 600 $\mu$ N	500 – 2,400
Ambipolar	0.25 – 10 mN	400 – 1,400
<b>4.6.3 PROPELLANTLESS PROPULSION TECHNOLOGIES</b>		
Solar Sails	TBD	N/A
Electrodynamic Tethers	TBD	N/A
Aerodynamic Drag	TBD	N/A

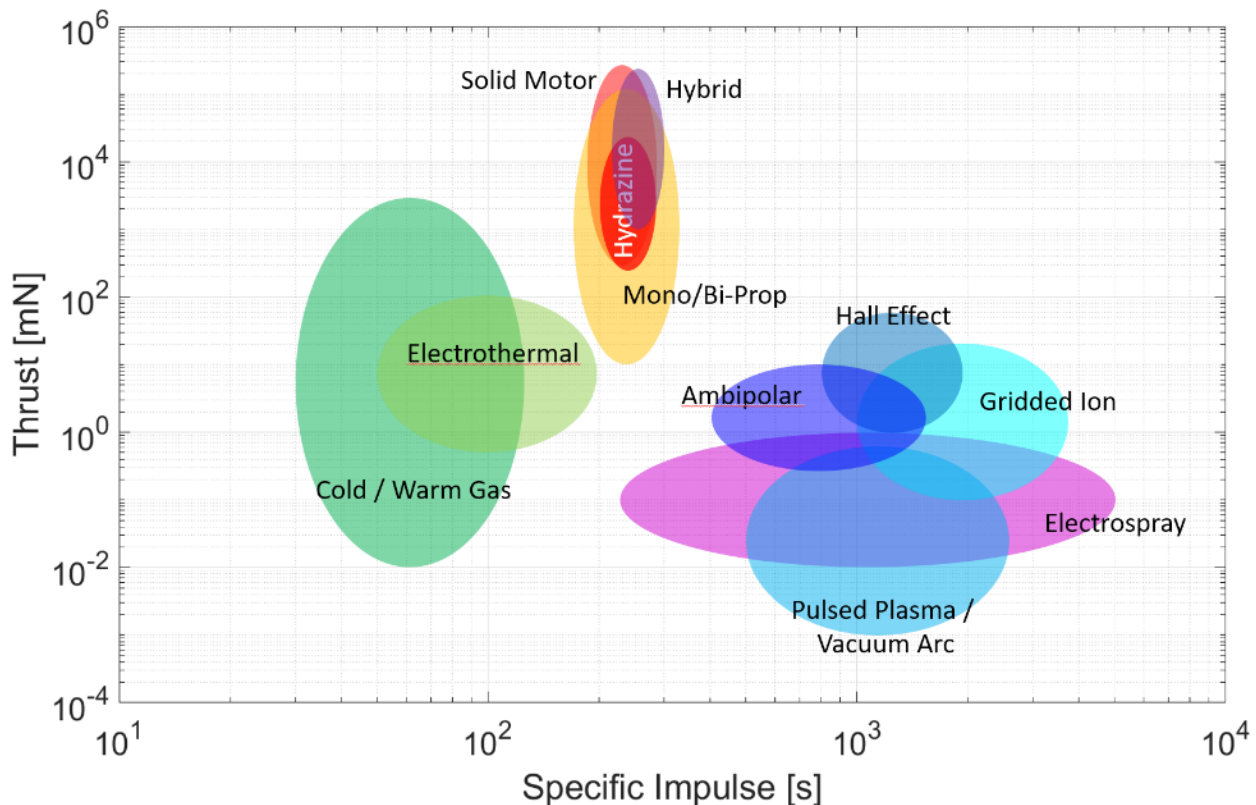


Figure 4.2: Typical small spacecraft in-space propulsion trade space (thrust vs. specific impulse). Credit: NASA.

## 4.6 State-of-the-Art in Small Spacecraft Propulsion

### 4.6.1 In-Space Chemical Propulsion

Chemical propulsion systems are designed to satisfy high-thrust impulsive maneuvers. They offer lower specific impulse compared to their electric propulsion counterparts but have significantly higher thrust to power ratios.

#### Hydrazine Monopropellant

##### a. Technology Description

Hydrazine monopropellant systems use catalyst structures (such as S-405 granular catalyst) to decompose hydrazine or a derivative such as monomethyl hydrazine (MMH) to produce hot gases. Hydrazine thrusters and systems have been in extensive use since the 1960's. The low mass and volume of a significant number of heritage hydrazine propulsion systems allows such systems to be suitable for use on small spacecraft buses. Hydrazine thrusters that have been used to perform small corrective maneuvers and attitude control on large spacecraft may be appropriate to act as the main propulsion system for small spacecraft. Hydrazine thrusters typically achieve a specific impulse between 200 – 235 seconds for 1-N class or larger thrusters.

##### b. Key Integration and Operational Considerations

- **Extensive Flight Heritage:** Since hydrazine has been used extensively in spaceflight applications, the technology's traits are well understood (4).



- **Extensive Component Ecosystem:** A robust ecosystem of components and experience exists because hydrazine systems are widely used. As such, hydrazine propulsion systems are frequently customized for specific applications using the available components.
- **Qualified for Multiple Cold Restarts:** These systems have the advantage of typically being qualified for multiple cold starts.
- **Extensive Safety and Handling Requirements:** Hydrazine and its derivatives are corrosive, toxic, and potentially carcinogenic. Its vapor requires the use of Self Contained Atmospheric Protective Ensemble (SCAPE) suits. This overhead must be considered when planning ground processing workflow for spacecraft and may impose undesirable constraints on the spacecraft, the launch provider, or other spacecraft participating in the same launch opportunity. Hydrazine propulsion systems typically incorporate redundant serial valves to prevent spills or leaking vapor, which might harm ground personnel or hardware.

#### c. Current & Planned Missions

ArianeGroup has developed a 1-N class hydrazine thruster that has extensive flight heritage, including use on the ALSAT-2 small spacecraft (5) (6).

Aerojet Rocketdyne has leveraged existing designs with flight heritage from large spacecraft that may be applicable to small buses, such as the MR-103 thruster used on New Horizons for attitude control (7). Other Aerojet Rocketdyne thrusters potentially applicable to small spacecraft include the MR-111 and the MR-106 (8). These thrusters have successfully flown on several missions.

Moog-ISP has extensive experience in the design and testing of propulsion systems and components for large spacecraft. These may also apply to smaller platforms, as some of their flight-proven thrusters are lightweight and have moderate power requirements. The MONARC-5 thrusters flew on NASA JPL's Soil Moisture Active Passive (SMAP) spacecraft in 2015 and provided 4.5 N of steady state thrust. Other thrusters potentially applicable to small spacecraft buses include the MONARC-1 and the MONARC-22 series (9).

#### d. Summary Table of Devices

See table 4-2 for current state-of-the-art hydrazine monopropellant devices applicable to small spacecraft.

#### e. Notable Advances

Aerojet Rocketdyne (AR) has developed a new class of green hydrazine propellant blends providing the low vapor-toxicity and high density-  $I_{SP}$  of ionic liquids while retaining the low reaction and preheat temperatures of traditional hydrazine. This makes it possible to increase both safety and performance while still using conventional nickel-alloy catalytic thrusters. In testing completed to date, green hydrazine blends have demonstrated long-term thermal stability/storability, low shock/impact sensitivity, and good operational stability. Furthermore, they have demonstrated a 100-fold reduction in vapor pressure/toxicity and a similar low-temperature start capability as compared to pure hydrazine (11). Ongoing development efforts at Aerojet Rocketdyne, NASA GSFC, and the Aerospace Corporation are on track to advance the technical maturity of green hydrazine blends to flight-ready status by the end of 2022.



## Alternative Monopropellants and Bipropellants

### a. Technology Description

Alternative propellant technologies are increasingly being developed and adopted as a replacement for hydrazine, due to hydrazine's handling and toxicity concerns. These include replacements such as the emerging 'green' ionic liquids, and more conventional propellants like hydrogen peroxide or electrolyzed water (bi-propellant hydrogen/oxygen).

The primary ionic liquid propellants with flight heritage or upcoming spaceflight plans are LMP-103S, which is a blend of Ammonium Dinitramide (ADN), and AF-M315E (now: referred to as "ASCENT"), a blend of Hydroxylammonium Nitrate (HAN). Other alternative propellants, such as hydrogen peroxide, are also available and have been in use for many years. Some of these may be lower performing than hydrazine but offer more benign operating environments and require more readily available and lower-cost materials.

This group of ionic liquid propellants, commonly referred as 'green propellants,' have reduced toxicity due in large part to the lower danger of component chemicals and significantly reduced vapor pressures as compared to hydrazine. The 'green' affiliation also results in potentially removing SCAPE suit requirements, which reduces operational oversight by safety and emergency personnel, and potentially reduces secondary payload requirements. The 'green propellants' LMP-103S and ASCENT are ideally used as direct replacements for hydrazine. Usually, these green propellants are decomposed and combusted over a catalytic structure akin to hydrazine systems, which often requires pre-heating to decompose the propellant. However, they both require high catalyst pre-heating and have higher combustion temperatures. Therefore, these blends are not 'drop-in' replacements.

Green propellants also provide higher specific impulse performance than the current state-of-the-art hydrazine monopropellant thrusters for similar thrust classes and have a higher density-specific impulse achieving improved mass fractions. Additionally, these propellants have lower minimum storage temperatures which may be beneficial in power-limited spacecraft, as tank and line heater requirements are lower.

While other alternative propellant choices (such as electrolyzed water or hydrogen peroxide) are not 'green' propellants like the ionic liquids, they may also be considered within the 'green' category. They exhibit more benign characteristics relative to hydrazine and are therefore an alternative option to hydrazine. These alternative propellants are seen as particularly useful for small satellite applications, where the comparatively low mission cost can provide a mutual benefit in technology advancement and development while providing needed mission capabilities (12).

### b. Key Integration and Operational Considerations

- **Improved Hazard Safety Classifications:** Air Force Range Safety AFSPCMAN91-710 (13) requirements state that if a propellant is less prone to external leakage, which is often seen with the ionic liquid 'green' propellant systems due to higher viscosity of the propellant, then the hazardous classification is reduced. External hydrazine leakage is considered "catastrophic," whereas using ionic liquid green propellants reduces the hazard severity classification to "critical" and possibly "marginal" per MIL-STD-882E (Standard Practice for System Safety) (14). A classification of "critical" or less only requires two-seals to inhibit external leakage, meaning no additional latch valves or other isolation devices are required in the feed system (14). While these propellants are not safe for consumption, they have been shown to be less toxic compared to hydrazine. This is primarily due to green propellants having lower vapor pressures, being less flammable,



and producing more benign constituent product gases (such as water vapor, hydrogen, and carbon dioxide) when combusted.

- **Simplified Safety and Handling Requirements:** Fueling spacecraft with green propellants, generally permitted as a parallel operation, may require a smaller exclusionary zone, allowing for accelerated launch readiness operations (15). These green propellants are also generally less likely to exothermically decompose at room temperature due to higher ignition thresholds. Therefore, they require fewer inhibit requirements, fewer valve seats for power, and less stringent temperature storage requirements. The reduced hazard associated with some of these propellants may enable projects to take a Design for Minimum Risk (DFMR) approach to address some propulsion system safety concerns, but only with the support of associated range and payload safety entities.
- **Immature Component Ecosystem:** While there are thrusters that are relatively mature (PMI E/F), incorporating them into integrated propulsion systems is challenging, and the maturity of stand-alone propulsion systems has lagged the pace of component development. Historically, research and development efforts, like Small Business Innovative Research (SBIR) efforts, have focused on component development, and not the entire system. Efforts are now being made to focus on the development of system solutions. Most of these non-toxic propellants are still in some phase of development. Additionally, data on the propellants is widely restricted. Therefore, a comprehensive, public, peer-reviewed databased of compatible materials does not currently exist, and would-be system developers using these propellants may have difficulty accessing such data to guide their efforts.
- **Other Considerations for Green Propellants:** Other 'green propellants' such as Hydrogen Peroxide, High Test Peroxide (HTP), and HTP/Alcohol bipropellants also have their own unique handling considerations. For instance, HTP is a strong oxidizer and can exothermically decompose rapidly if improperly stored or handled. Hydrogen Peroxide, however, has been used as a rocket propellant for many decades, and there is a lot of information on safe handling, materials selection, and best practices. Electrolyzed water is another propellant option, wherein water is decomposed into hydrogen and oxygen and combusted as a traditional bi-propellant thruster. However, generating and managing the power required to electrolyze the water in a compact spacecraft presents its own unique challenges. Yet it does provide a safe-to-launch system with very benign constituents.

### c. Current & Planned Missions

Planet Labs launched a constellation of Earth observing satellites, called SkySat. These satellites are approximately 120 kg, and incorporate the Bradford-ECAPS HPGP system, a LMP-103S based system shown in figure 4.3. SkySat's 3 – 21 include a propulsion system using four 1-N thrusters. As of August 2020, 13 SkySat satellites with the Bradford ECAPS propulsion system have been launched and are fully operational (16).



Figure 4.3: ECAPS HPGP thruster.  
Credit: Bradford ECAPS.

AstroScale has built and launched a highly maneuverable 'chaser' SmallSat called ELSA-d. ELSA-d has an LMP-103S using eight 1-N Bradford ECAPS thrusters to provide both re-orbiting and de-orbiting capability. The ELSA-d mission demonstrated many key rendezvous technologies, despite not being able to ultimately demonstrate autonomous capture. A system issue impacted three of eight Bradford ECAPS

thrusters and an unresolved root cause resulted in the loss of a fourth thruster. Nevertheless, many mission goals were successfully accomplished, improving the providers readiness for offering a commercial deorbit service (17) (18). ELSA-d launched in March 2021.

The JPL-led Lunar Flashlight mission, manifested as a secondary payload for a December 2022 Falcon 9 launch, will map the lunar south pole for volatiles. The mission will demonstrate several technological firsts, including being one of the first CubeSats to reach the Moon, the first planetary CubeSat mission to use green propulsion, and the first mission to use lasers to look for water ice (20).

NASA Marshall Space Flight Center (MSFC) led the development of the Lunar Flashlight Propulsion System (LFPS), a self-contained unit that can deliver over 3000 N-s of total impulse for this mission (figure 4.4). The LFPS is a pump-fed system that has four 100-mN ASCENT thrusters (figure 4.5), built by Plasma Processes LLC., and a micro-pump built by Flight Works Inc. The LFPS employs a propellant management device (PMD) and newly developed isolation and thruster micro-solenoid valves and a micro-fill/drain valve. The LFPS system was delivered to JPL in May 2021. The LFPS structural design and electronics controller development was performed by the Georgia Institute of Technology (Atlanta, GA).

Another ASCENT-based propulsion system flew as a technology demonstration on the NASA Green Propellant Infusion Mission (GPIM) launched in July 2019 (21). This small spacecraft was designed to test the performance of this propulsion technology in space by using five 1-N class thrusters (figure 4.6) for small attitude control maneuvers (22). Aerojet completed a hot-fire test of the GR-1 version in 2014 and further tests in 2015. Initial plans to incorporate the GR-22 thruster (22-N class) on the GPIM mission were deferred in mid-2015 to allow for more development and testing of the GR-22. As a result, the GPIM mission only carried and demonstrated five GR-1 units when launched (23).

CisLunar Explorer, part of a NASA Centennial Challenge mission on Artemis I, will use a water electrolysis system developed by Cornell University (24). The CisLunar Explorer's concept consists of a pair of spacecrafts on a mission to orbit the Moon. The two spacecraft are mated together as a "6U"-sized box, and after deployment from the launch vehicle, they will split apart, and each give their initial rotation in the process of decoupling. The spacecraft will then enter and attempt to maintain lunar orbit.

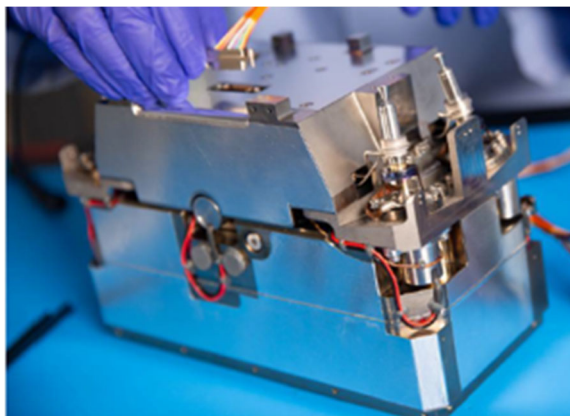


Figure 4.4: Lunar Flashlight Propulsion System. Credit: NASA.



Figure 4.5: Plasma Processes LLC 100mN thruster. Credit: NASA MSFC.



Figure 4.6: GR1 thruster. Credit: Aerojet.



NASA's Small Spacecraft Technology (SST) program at Ames Research Center (ARC) launched the first Pathfinder Technology Demonstration (PTD) mission in January 2021 (25) (26) (27). PTD-1 (figure 4.7) tested the HYDROS-C water electrolysis propulsion system, developed by Tethers Unlimited Inc. With a volume less than 2.4U, the HYDROS-C uses water as propellant. In-orbit, water was electrolyzed into oxygen and hydrogen, then combusted like a traditional bi-propellant thruster. Limited performance data has been evaluated and made public (28). The system requires 10 – 15 minutes of recharge time between pulses. A variant of the HYDROS-C system is the HYDROS-M system, which is intended to be sized for MicroSats.

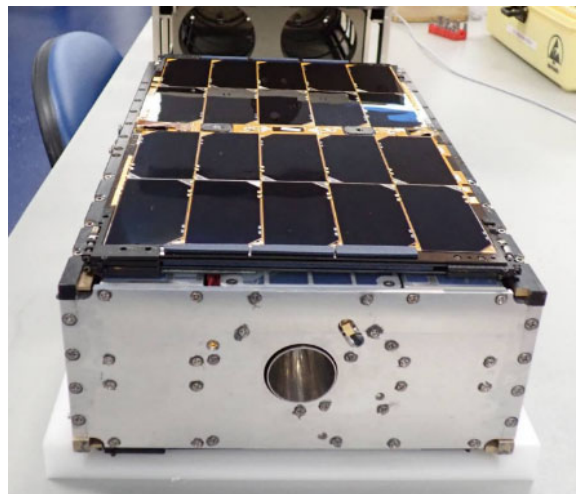


Figure 4.7: PTD-1 HYDROS-C. Credit: NASA.

Benchmark Space Systems delivered its first three Halcyon propulsion systems (figure 4.8), which launched on June 30, 2021 on SpaceX's Transporter-2 rideshare mission. The Halcyon system combines an HTP thruster developed by legacy Tesseract with Benchmark's fluid handling and flight controller subsystems to provide a thrust of 1-N with an  $I_{sp}$  between 155-175s. It uses proprietary on-demand pressurization technology, permitting it to be launch at low pressure (29).

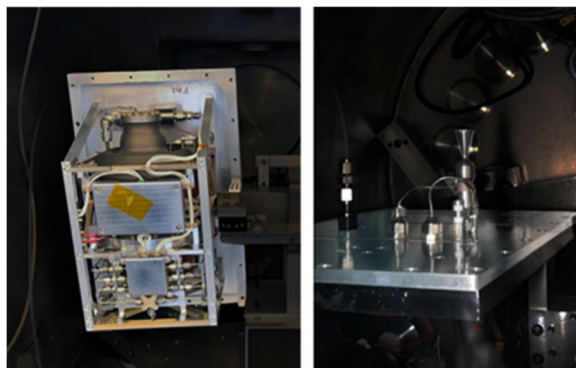


Figure 4.8: Benchmark's Halcyon in Test. Credit: Benchmark Space Systems.

VACCO Industries built and delivered the first of its Integrated Propulsion System (IPS), which was designed to deliver 12,000 N-sec total impulse. The IPS (figure 4.9) features four 1-N LMP-103S Bradford ECAPS thrusters, using the LFP-103S propellant.

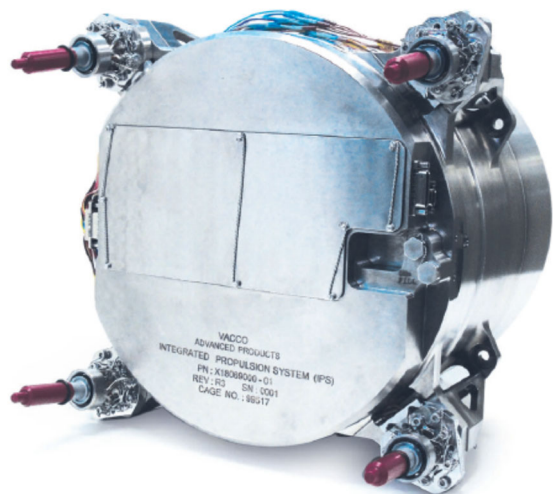


Figure 4.9: VACCO Industries IPS. Credit: VACCO Industries.

NanoAvionics developed a non-toxic mono-propellant propulsion system called Enabling Propulsion System for Small Satellites (EPSS), which was demonstrated on LituaniaSAT-2, a 3U CubeSat, to correct orientation and attitude, avoid collisions, and extend orbital lifetime. It uses an ADN-blend as propellant, achieves 213 s of specific impulse, and provide 400 N-s of total impulse. LituaniaSAT-2 was launched in June 2017 and successfully separated from the primary payload (Cartosat-2) as part of the European QB50 initiative. According to product literature, multiple missions have since launched, with the latest being in April 2019 (30).



Dawn Aerospace and AAC Hyperion have co-developed a 0.5 N bi-propellant system that consists of a single thruster with a gimbal to provide thrust in two axes. The 1U configuration (figure 4.10) provides 850 N-s of total impulse with a minimum impulse bit of 35 mN-s (31).

Rocket Lab's Electron rocket has a liquid propellant kick-stage that uses a cold-gas RCS. The Rocket Lab Kick Stage, powered by the Curie engine, was designed to deliver small satellites to precise orbits before deorbiting itself to leave no part of the rocket in space. The kick stage was flown and tested onboard the "Still Testing" flight that was successfully launched on January 21, 2018. With the new kick stage Rocket Lab can execute multiple burns to place numerous payloads into different orbits. The kick stage is designed for use on the Electron launch vehicle with a payload capacity of up to 150 kg, and will be used to disperse CubeSat constellations fast and accurately, enabling satellite data to be received and used soon after launch (32) (33).



Figure 4.10: PM200. Credit: Dawn Aerospace.

#### d. Summary Table of Devices

See table 4-3 for the current state-of-the-art in other mono- and bipropellant devices applicable to small spacecraft.

#### e. Notable Advances

Aerojet Rocketdyne continues to develop its GR-M1 Advanced Green Monopropellant CubeSat Thruster. It employs the same advanced techniques, ultra-high-temperature catalyst, and refractory metal manufacture as the GPIM GR-1 thruster, but on a nanosat scale (34). To partially mitigate thermal management challenges exacerbated at the miniature scale, the GR-M1 is designed to operate on a reduced-flame-temperature variant of the AF M315E propellant containing 10% added water. The heat transfer to surrounding spacecraft structure both during heat up and operation are comparable to conventional hydrazine thrusters.

Plasma Processes LLC is maturing a 1N and 5N ASCENT thruster (figure 4.11), intended for SmallSat application (35). Both offerings are built using the same materials and processes as those used on the 100mN thrusters delivered for the Lunar Flashlight Mission. Additionally, Plasma Processes intends to engineer a short-life, lower cost version of the 5N thruster. The prototype thruster accumulated > 1kg throughput and over 500 seconds before the end of the NASA Phase I SBIR. The Phase II effort will continue to develop the 5N thruster.

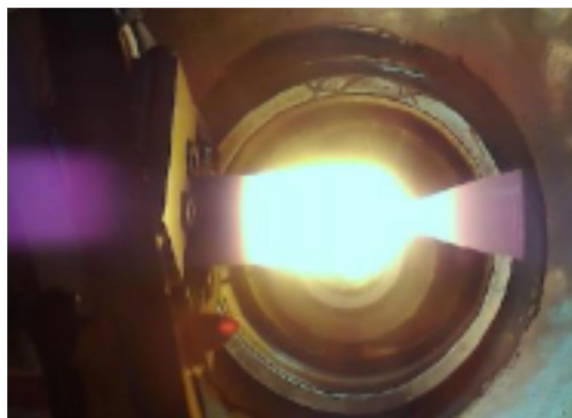


Figure 4.11: PP3616-A 5N ASCENT Thruster. Credit: Plasma Processes.



CU Aerospace LLC (CUA) is developing the Monopropellant Propulsion Unit for CubeSats (MPUC) system. The monopropellant is an  $\text{H}_2\text{O}_2$ -ethanol blend denoted as CMP-X. Tests on a thrust stand typically spanning >10 minutes achieved a thrust level of >100 mN at  $I_{SP}$  >180 s with an average input power of ~6 W during catalyst warmup. 1.5U and 2U systems are in development with an estimated 1550 N-s and 2450 N-s total impulse, respectively. A ~950°C flame temperature allows the thrust chamber to use non-refractory construction materials. CMP-X has low toxicity and was subjected to UN Series 1, 2, 3, and 6 testing; CMP-X demonstrated no detonation propagation when confined under a charge of high explosive, it exhibited thermal stability with no explosion or detonation during bonfire testing, and was not sensitive to drop impact or friction. CMP-X passed the criteria for either a 1.4S or a “Not Class 1” determination and may be excluded from the explosive class. Long-term storage testing shows no degradation over > 600 days with testing ongoing. A NASA Phase II SBIR effort is currently underway.

## Hybrids

### a. Technology Description

Hybrid propulsion is a mix of both solid and liquid/gas forms of propulsion. In a hybrid rocket, the fuel is typically a solid grain, and the oxidizer (often gaseous oxygen) is stored separately. The rocket is then ignited by injecting the oxidizer into the solid motor and igniting it with a spark or torch system. Since combustion can only occur while the oxidizer is flowing, these systems can readily be started or shut down by controlling the oxidizer flow.

### b. Key Integration and Operational Considerations

- **Improved Safety and Handling:** Hybrid systems are inherently safer to handle than solid motor systems because there is no oxidizer pre-mixed into the solid motor, which reduces the risk of pre-mature ignition.
- **Integrates Attributes of Solids and Liquids:** Hybrids achieve many positive attributes of both solid motors (storability & handling) and liquid engines (restart & throttling).
- **Combustion Efficiency:** Combustion efficiency tends to be lower than either solid motors or liquid engines.
- **Other Drawbacks:** Regression rate control and fuel residuals tend to be more problematic in hybrid designs.

### c. Current & Planned Missions

An arc-ignition 'green' CubeSat hybrid thruster system prototype was developed at Utah State University. This system is fueled by 3-D printed acrylonitrile butadiene styrene (ABS) plastic known for its electrical breakdown properties. Initially, high-pressure gaseous oxygen (GOX) was to be used as the oxidizer. However, for the sake of the technology demonstration and after safety considerations by NASA Wallops High Pressure Safety Management Team, it was concluded the oxidizer needed to contain 60% nitrogen and only 40% oxygen. On March 25, 2018, the system was successfully tested aboard a sounding rocket launched from NASA Wallops Flight Facility (WFF) into space and the motor was successfully re-fired 5 times. During the tests, 8 N of thrust and a specific impulse of 215 s were achieved as predicted (37) (38). The Space Dynamics Lab has miniaturized this technology to be better suited for CubeSat applications (0.25 - 0.5 N). A qualification unit is currently in development for the miniaturized system.

### d. Summary Table of Devices

See table 4-4 for current state-of-the-art hybrid devices applicable to small spacecraft.



#### e. Notable Advances

Utah State University has an ongoing test series with Nytrox, a blend of nitrous oxide and oxygen, and ABS. This testing is focused on a 25-50 N system for a 12U sized vehicle. Investigation into different nozzle materials for low erosion in long duration burns is a key concern (39) (40).

JPL has pursued development of a hybrid propulsion system for 12U CubeSat and a 100 kg SmallSat. Testing included regression rate characterization of clear and black Poly (Methyl MethAcrylate) fuels with GOX to be included in propulsion system sizing. Later vacuum testing included an improvement of the ignition system to a laser operated system that eliminates the need for a separate ignition fuel gas to be carried (41).

NASA ARC developed a polymethyl methacrylate (PMMA) and nitrous oxide hybrid system that had ethylene and nitrous oxide thrusters. The ethylene and nitrous oxide also function as the hybrid ignition source. The hybrid system had a demonstrated efficiency of 91% and calculated  $I_{SP}$  of 247 sec, making it competitive with current small satellite propulsion systems (42) (43).

Aerospace Corporation and Penn State University developed an “Advanced Hybrid Rocket Motor Propulsion Unit for CubeSats (PUC)”. The design used additive manufacturing techniques for the carbon filled polyamide structure including the nitrous oxide tank and a paraffin grain within an acrylic shell, with acrylic diaphragms 3-D printed in-situ in the grain to aid in the performance of the grain. This design fits in a 1U space, for a 3 to 6U spacecraft (44).

Parabilis Space Technologies has done development work on two small satellite propulsion systems. Rapid Orbital Mobility Bus (ROMBUS) is a hybrid rocket-based system with nitrous oxide as the oxidizer and the attitude control system/reaction control system thruster propellant. It provides high-impulse thrust for satellite translational maneuvers which can be used for initial orbit insertion, rapid orbit rephasing, threat/collision avoidance, and targeted re-entry at the satellite’s mission end of life (45). Nano Orbital Transfer System (OTS) is a Hydroxyl-terminated polybutadiene (HTPB) and nitrous oxide ( $N_2O$ ) hybrid system, with  $N_2O$  based ACS thrusters. Nano OTS leverages Parabilis’ proven hybrid engine and small satellite technologies for low-cost, high-performance maneuvers using non-toxic green propellants. The OTS has a modular design, enabling rapid and low-cost configuration of stages to accommodate 3U size NanoSats up to >50 kg MicroSat-size vehicles.

#### Cold Gas / Warm Gas

##### a. Technology Description

Cold gas propulsion systems are simple, mature, and safe, although they provide relatively limited total impulse. Thrust is produced by the expulsion of a gaseous propellant through a diverging nozzle. The propellant is typically stored as a pressurized gas or a saturated liquid. A derivative of cold gas systems is ‘warm gas’ systems, in which the propellant is somewhat heated (<1000 K) without chemical reaction. The additional heating results in a modest improvement in thrust and specific impulse compared to a pure cold gas system, although typically burdens the spacecraft with increased power consumption. Electrothermal systems, a type of warm-gas system where the gas is electrically heated in the thruster body or nozzle, are described in more detail in the Electric Propulsion section.

##### b. Key Integration and Operational Considerations

- **Low Cost and Complexity:** Cold gas thrusters are often attractive and suitable for small buses due to their relatively low cost and complexity.
- **Safe:** Most cold gas thrusters use inert, non-toxic propellants, which are an advantage for secondary payloads that must adopt “do no harm” approaches to primary payloads.

- **Small Impulse Bit:** Cold gas systems are often well suited to provide attitude control since they can provide very small minimum impulse bits for precise maneuvering.
- **Small Total Impulse:** The low specific impulse of these systems limits them from providing large orbital correction maneuvers.
- **Integrated Systems Optimized for CubeSats:** Designs optimized around the limit resources of CubeSats have improved the capability of these systems for nanosatellite buses.

### c. Missions

A cold gas thruster developed by Marotta flew on the NASA ST-5 mission (launch mass 55 kg) for fine attitude adjustment maneuvers. It incorporates electronic drivers that can operate the thruster at a power of less than 1 W. It has less than 5 ms of response time and it uses gaseous nitrogen as propellant (46).

The Micro-Electromechanical-based PICOSAT Satellite Inspector, or MEPSI, built by the Aerospace Corporation flew aboard STS-113 and STS-116. The spacecraft included both target and imaging/inspector vehicles connected via tether. The two vehicles were 4 x 4 x 5 in<sup>3</sup> in volume, each, and had five cold-gas thrusters, producing ~20 mN. The MEPSI propulsion system was produced using stereo-lithography. It was suited as a propulsion research unit for PicoSats (47).

Surrey Satellite Technology Ltd. (SSTL) has included a butane propulsion system in several small spacecraft missions for a wide range of applications in low-Earth orbit and medium-Earth orbit (MEO). In this system, propellant tanks are combined with a resistojet thruster and operation is controlled by a series of solenoid valves (figure 4.12). It requires power to heat the thruster and improve the specific impulse performance with respect to the cold gas mode. (48) (49).



Figure 4.12: SSTL butane propulsion system. Credit: Surrey Satellite Technology, Ltd.

In June 2014, Space Flight Laboratory at University of Toronto Institute for Aerospace Research (UTIAS) launched two 15 kg small spacecraft to demonstrate formation flying. The Canadian Nanosatellite Advanced Propulsion System (CNAPS), shown in figure 4.13, consisted of four thrusters fueled with liquid sulfur hexafluoride. This non-toxic propellant was selected because it has high vapor pressure and density, which is important for making a self-pressurizing system (50). This propulsion module is a novel version of the previous NanoPS that flew on the CanX-2 mission in 2008 (51).

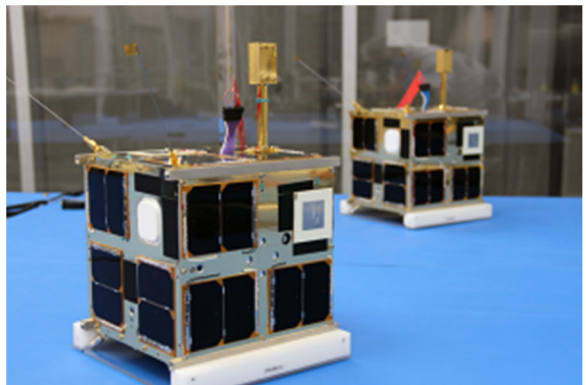


Figure 4.13: CanX-4 and CanX-5 formation flying nanosatellites with CNAPS propulsion systems. Credit: UTIAS SFL.

Another flight-demonstrated propulsion system was flown on the POPSAT-HIP1 CubeSat mission (launched June 2014), which was developed by Microspace Rapid Pte Ltd in Singapore. It consisted of eight micro-nozzles that provided control for three rotation axes with a single thrust

axis for translational applications. The total delta-v has been estimated from laboratory data to be between 2.25 and 3.05  $\text{ms}^{-1}$ . Each thruster has 1 mN of nominal thrust by using argon propellant. An electromagnetic microvalve with a very short opening time of 1 m-s operates each thruster (52).

Two related butane propulsion systems have been developed by GomSpace: the NanoProp 3U and NanoProp 6U. Both use proportional thrust control of four nozzles to control spacecraft attitude while providing delta-v. The 6U configuration was flown on GOMX-4B in 2018 as a formation flight demonstration (53) (54).

An ACS cold gas propulsion system using R-236fa was produced and tested by Lightsey Space Research for the NASA ARC BioSentinel mission, a 6U CubeSat that launched on Artemis I November 2022. This propulsion system uses a 3D-printed propellant tank in order to reduce part count and make efficient use of the available volume (55) (56).



*Figure 4.14: NanoSpace MEMS cold gas system. Credit: GomSpace.*

A complete cold gas propulsion system has been developed for CubeSats with a microelectromechanical system (MEMS) (figure 4.14) that provides accurate thrust control with four butane propellant thrusters. While thrust is controlled in a closed loop system with magnitude readings, each thruster can provide a thrust magnitude from zero to full capacity (1 mN) with 5- $\mu\text{N}$  resolution. The dry mass of the system is 0.220 kg and average power consumption is 2 W during operation (57). This system is based on flight-proven technology flown on larger spacecraft (PRISMA mission, launched in 2010). The MEMS cold gas system was included on the bus of the TW-1 CubeSat, launched in September 2015 (58).

The CubeSat Proximity Operations Demonstration (CPOD) is a mission led by Tyvak Nano-Satellite Systems (59). It incorporates a cold gas propulsion system built by VACCO Industries that provides up to 186 N-s of total impulse. This module operates at a steady state power of 5 W and delivers 40-s of specific impulse while the nominal thrust is 10 mN (60). It uses self-pressurizing refrigerant R236fa propellant to fire a total of eight thrusters distributed in pairs at the four corners of the module. It has gone through extensive testing at the US Air Force Research Lab. Endurance tests consisted of more than 70,000 firings.

JPL is supporting the InSight mission, launched in March 2018, which incorporated two identical CubeSats as part of the Mars Cube One (MarCO) technology demonstration. These spacecraft performed five trajectory correction maneuvers (TCMs) during the mission to Mars. The CubeSats included an integrated propulsion system developed by VACCO Industries, which contained four thrusters for attitude control and another four for TCMs. The module uses cold gas refrigerant R-236FA as propellant, produces 75 N-s of total impulse, and weighs 3.49 kg (61) (62).

NEA Scout is a NASA MSFC mission that was launched on Artemis I in November 2022. For its main propulsion system, NEA Scout will deploy a sail of 80  $\text{m}^2$  with 0.0601- $\text{mm s}^{-2}$  of characteristic acceleration that will be steered by active mass translation via a VACCO cold gas MiPS (R236FA propellant). This module is approximately 2U in volume and will use six 23-mN thrusters to provide 30  $\text{m s}^{-1}$  of delta-v (63) (64).

The ThrustMe I2T5 iodine cold gas module, figure 4.15, is the first iodine propulsion system to be spaceflight tested, on-board of the Xiaoxiang 1-08 satellite. The demonstration was the result of a collaboration of ThrustMe and Spacety (65) (66). An I2T5 module is anticipated to launch in 2022 on the Robusta-3A satellite, developed by CSUM. The Robusta-3A will carry various scientific payloads related to meteorology and technology demonstration (67).



Figure 4.15: I2T5 Iodine Cold Gas Module. Credit: ThrustMe.

#### d. Summary Table of Devices

See table 4-5 for the current state-of-the-art cold gas / warm gas devices applicable to small spacecraft.

### Solid Motors

#### a. Technology Description

Solid rocket technology is typically used for impulsive maneuvers such as orbit insertion or quick de-orbiting. They achieve moderate specific impulses and high thrust magnitudes. There are some electrically controlled solid thrusters that operate in the milli-newton (mN) range that are restartable and have steering capabilities. Solid rocket technology can be compact and suitable for small buses.

#### b. Key Integration and Operational Considerations

- **Thrust Vector Control:** Thrust vector control systems can be coupled with existing solid rocket motors to provide controllable high delta-v maneuvering.
- **Usually Single-Burn:** In general, solid motors are considered a single-burn event system. To achieve multiple burns, the system must be either electrically restartable (aka electric solid propellants), or several small units must be matrixed into an array configuration. Because electrically controlled solid propellant (ESPs) are electrically ignited, they are considered safer than traditional solid energetic propellants.

#### c. Current & Planned Missions

A flight campaign tested the ability of thrust vector control systems coupled with solid motors to effectively control the attitude of small rocket vehicles. Some of these tests were performed by using state-of-the-art solid rocket motors such as the ISP 30 developed by Industrial Solid Propulsion and the STAR 4G by ATK (now Northrop Grumman) (69).



Figure 4.16: SpinSat at the ISS. Credit: NASA.

SpinSat, a 57 kg spacecraft, was deployed from the International Space Station (ISS) in 2014 and incorporated a set of first-generation solid motors, the CubeSat Agile Propulsion System (figure 4.16), which was part of the attitude control system developed by Digital Solid State Propulsion LLC

(DSSP). The system was based on a set of ESP thrusters that consists of two coaxial electrodes separated by a thin layer of electric solid propellant. This material is highly energetic but non-pyrotechnic and is only ignited if an electric current is applied. The thrust duration can be better

controlled, allows for better burn control, and the lack of moving parts makes the system suitable for small spacecraft (70).

The Modular Architecture Propulsion System (MAPS) by Pacific Scientific Energetic Materials Company (PacSci EMC) Propulsion array (figure 4.17) has a 10-plus year in-orbit lifespan. The MAPS system provides three axes capability to control such areas as attitude control, deorbit, drag makeup, and plane and attitude changes with a delta- $v$  greater than  $50 \text{ m s}^{-1}$ . The capability of MAPS “plug-and-play” bolt-on design and clean-burning propellant array is scalable and can be custom fit for a range of interfaces. MAPS was flown aboard the PACSCISAT (71) (72).

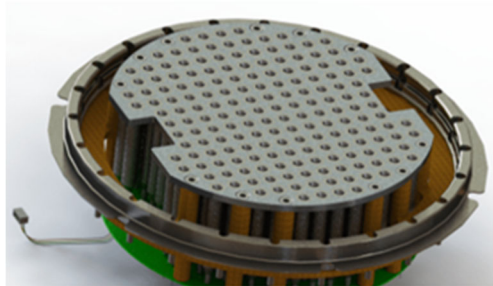


Figure 4.17: PacSci EMC MAPS sealed solid propellant rocket motor array. Credit: PacSci.

#### d. Summary Table of Devices

See table 4-6 for the current state-of-the-art solid motor devices applicable to small spacecraft.

### Propellant Management Devices

#### a. Technology Description

While not specifically a propulsion type, propellant management devices (PMDs) are frequently used in large liquid propulsion systems to reliably deliver propellant to thruster units. PMDs are a critical part of any in-space liquid propulsion system that doesn't use bellows or membrane type tanks. As small spacecraft look toward more complex propulsion requirements, PMDs will undoubtedly play an integral role. Historically, small spacecraft have used bellows or membrane tanks to ensure propellant delivery and expulsion. However, there is the potential to incorporate PMD structures into additively manufactured tanks and propulsion systems, permitting more conformal structures to be created and optimized for small spacecraft missions. As such, PMDs are briefly covered here for awareness. A more detailed treatment and explanation can be found in literature. A comprehensive, up-to-date list of the types of PMDs, as well as missions employing PMDs, is available in Hartwig (73).

#### b. Key Integration and Operational Considerations

The purpose of PMDs is to separate liquid and vapor phases within the propellant storage tank upstream of the thruster, and to transfer vapor-free propellant in any gravitational or thermal environment. PMDs have flight heritage with all classical storage systems, have been flown once with LMP-103S, have no flight heritage with cryogenic propellants, and have been implemented in electric propulsion systems. Multiple PMDs are often required to meet the demands of a particular mission, whether using storable or cryogenic propellants.

#### c. Current & Planned Missions

The Lunar Flashlight Propulsion System will employ a PMD sponge and ribbon vane. The sponge was additively manufactured, while the ribbon vane was cut from sheet metal and bent to conform to the required dimensions. Surface tension properties, a necessary parameter for PMD sizing, have been determined for the ASCENT propellant by Kent State University, funded and managed by NASA. The design and modelling effort were a joint effort between MSFC and GRC.

#### d. Summary Table of Devices

No summary table is included for propellant management devices in this report edition.



#### e. Notable Advances

Northrop Grumman has made advances in development of SmallSat and CubeSat scale diaphragm propellant tanks using materials with known compatibility with hydrazine and some green monopropellant fuels (74). Some effort has been made to demonstrate the application of additive manufacturing to produce tank shells.

#### 4.6.2 In-Space Electric Propulsion

In-space electric propulsion (EP) is any in-space propulsion technology wherein a propellant is accelerated through the conversion of electrical energy into kinetic energy. The electrical energy source powering in-space EP is historically solar, therefore these technologies are often referred to as solar electric propulsion (SEP), although other energy sources are conceivable such as nuclear reactors or beamed energy. The energy conversion occurs by one of three mechanisms: electrothermal, electrostatic, or electromagnetic acceleration (120) (121). Each of these technologies are covered herein.

This survey of the state-of-the-art in EP does not attempt to review all known devices but focuses on those devices that can be commercially procured or devices that appear on a path toward commercial availability. The intent is to aid mission design groups and other in-space propulsion end-users by improving their awareness of the full breadth of potentially procurable EP devices that may meet their mission requirements.

Metrics associated with the nominal operating condition for each propulsion device are published herein, rather than metrics for the complete operating range. A focus on the nominal operating condition was decided to improve comprehension of the data and make initial device comparisons more straightforward. When a manufacturer has not specifically stated a nominal operating condition in literature, the manufacturer may have been contacted to determine a recommended nominal operating condition, otherwise a nominal operating condition was assumed based on similarity to other devices. For those metrics not specifically found in published literature, approximations have been made when calculable from available data. Readers are strongly encouraged to follow the references cited to the literature describing each device's full performance range and capabilities.

#### Electrothermal

##### a. Technology Description

Electrothermal technologies use electrical energy to increase the enthalpy of a propellant, whereas chemical technologies rely on exothermal chemical reactions. Once heated, the propellant is accelerated and expelled through a conventional converging-diverging nozzle to convert the acquired energy into kinetic energy, like chemical propulsion systems. The specific impulse achieved with electrothermal devices is typically of similar magnitude as chemical devices given that both electrothermal and chemical devices are fundamentally limited by the working temperature limits of materials. However, electrothermal technologies can achieve somewhat higher specific impulses than chemical systems since they are not subject to the limits of chemical energy storage.

Electrothermal devices are typically subclassified within one of the following three categories.

1. *Resistojet devices* employ an electrical heater to raise the temperature of a surface that in turn increases the bulk temperature of a gaseous propellant.
2. *Arcjet devices* sustain an electrical arc through an ionized gaseous propellant, resulting in ohmic heating.





3. *Electrodeless* thrusters heat a gaseous propellant through an inductively or capacitively coupled discharge or by radiation.

Systems where the propellant enthalpy is increased by electrical heating within the propellant tank, rather than heating in the thruster head, are covered in the chemical propulsion section under cold/warm gas systems.

#### b. Key Integration and Operational Considerations

- **Propellant Selection:** Electrothermal technologies offer some of the most lenient restrictions on propellant selection for in-space propulsion. Whereas chemical systems require propellants with both the right chemical and physical properties to achieve the desired performance, electrothermal systems primarily depend on acceptable physical properties. For example, electrothermal devices can often employ inert gases or even waste products such as water and carbon dioxide. They also allow use of novel propellants such as high storage density refrigerants or in-situ resources. That said, not all propellants can be electrothermally heated without negative consequences. Thermal decomposition of many complex molecules results in the formation of polymers and other inconvenient byproducts. These byproducts may result in clogging of the propulsion system and/or spacecraft contamination.
- **Propellant Storage:** Electrothermal devices may require that propellants be maintained at a high plenum pressure to operate efficiently. This may require a high-pressure propellant storage and delivery system.
- **High Temperature Materials:** The working temperature limit of propellant wetted surfaces in the thruster head is a key limitation on the performance of electrothermal devices. As such, very high temperature materials, such as tungsten and molybdenum alloys, are often employed to maximize performance. The total mass and shape of these high temperature materials are a safety consideration for spacecraft disposal. While most spacecraft materials burnup on re-entry, the behavior of these high temperature materials will be considered when assessing the danger of re-entry debris to life and property.
- **Power Processing:** While some simple resistojets may operate directly from spacecraft bus power, other electrothermal devices may require a relatively complex power processing unit (PPU). For example, a radio-frequency electrodeless thruster requires circuitry to convert the direct current bus power to a high-frequency alternating current. In some cases, the cost and integration challenges of the PPU can greatly exceed those of the thruster.
- **Thermal Soak-back:** Given the high operating temperatures of electrothermal devices, any reliance on the spacecraft for thermal management of the thruster head should be assessed. While the ideal propulsion system would apply no thermal load on the spacecraft, some thermal soak-back to the spacecraft is inevitable, whether through the mounting structure, propellant lines, cable harness, or radiation.

#### c. Missions

The Bradford (formerly Deep Space Industries) Comet water-based electrothermal propulsion system (figure 4.18) has been implemented by multiple customers operating in low-Earth orbit, including HawkEye 360, Capella Space, and BlackSky Global (122). All missions employ the same Comet thruster head, while the BlackSky Global satellites use a larger tank to provide a greater total impulse capability. The three HawkEye 360 pathfinder spacecraft employ the Space

Flight Laboratory NEMO platform with each spacecraft measuring 20 x 20 x 44 cm<sup>3</sup> with a mass of 13.4 kg (123) (124). The Comet provides each HawkEye 360 pathfinder a total delta-v capability of 96 ms<sup>-1</sup>. The approximate dimensions of the BlackSky Global spacecraft are 55 x 67 x 86 cm<sup>3</sup> with a mass of 56 kg (125).

The Propulsion Unit for CubeSats (PUC) system (126), figure 4.20, was designed and fabricated by CU Aerospace LLC (Champaign, IL) and VACCO Industries under contract with the U.S. Air Force to supply two government missions (127). The system was acquired for drag makeup capability to extend asset lifetime in low-Earth orbit. The system uses SO<sub>2</sub> as a self-pressurizing liquid propellant. The propulsion system electrothermally heats the propellant using a micro-cavity discharge (MCD) and expels the propellant through a single nozzle (128). It can alternatively use R134a or R236fa propellants, but only in a cold-gas mode with reduced performance. Eight (8) flight units were delivered to the Air Force in 2014, although it remains unknown if any of the units have flown.

In 2019, CU Aerospace was selected for a NASA STMD Tipping Point award to design, fabricate, integrate, and perform mission operations for the Dual Propulsion Experiment (DUPLEX) 6U CubeSat having two of CU Aerospace's micro-propulsion systems onboard, one Monofilament Vaporization Propulsion (MVP) system (129) (130) (131), figure 4.19, and one Fiber-Fed Pulsed Plasma Thruster (FPPT) system (132) (133) (134) (135) (136), figure 4.45. The MVP is an electrothermal device that vaporizes and heats an inert solid polymer propellant fiber to 725 K. The coiled solid filament approach for propellant storage and delivery addresses common propellant safety concerns, which often limit the application of propulsion on low-cost CubeSats. In-orbit operations will include inclination change, orbit raising and lowering, drag makeup, and deorbit burns demonstrating multiple mission capabilities with approximately 17 hours of operation for MVP and >20,000 hours for FPPT. Launch is manifested in early-2023 (137).

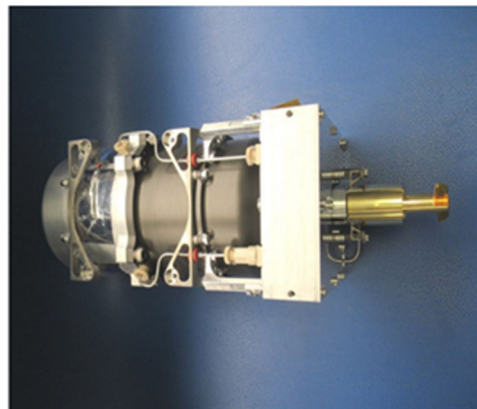


Figure 4.18: Comet-1000. Credit: Bradford Space.



Figure 4.20: PUC module. Credit: CU Aerospace LLC.



Figure 4.19: MVP module. Credit: CU Aerospace.

AuroraSat-1 is a technology demonstration 1.5U CubeSat that is demonstrating multiple propulsion devices by Aurora Propulsion Technologies. AuroraSat-1 carries Aurora's smallest version of Aurora Resistojet Module for Attitude control (ARM-A) (138), figure 4.21, and a demonstration unit of their Plasma Brake Module (PBM) (139). The ARM-A system integrated into AuroraSat-1 has six resistojet thrusters for full 3-axis attitude control and 70 grams of water propellant, providing a total impulse of 70 N-s. AuroraSat-1 is built by SatRevolution with Aurora providing the payloads. The satellite was launched by Rocket Lab in May 2022. (140) (141). See section 4.6.3 for discussion of the PBM module.

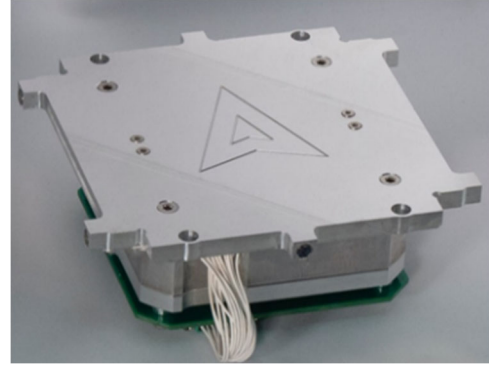


Figure 4.21: Aurora Resistojet Module for Attitude Control. Credit: Aurora Propulsion Technologies.

#### d. Summary Table of Devices

See table 4-7 for current state-of-the-art electrothermal devices applicable to small spacecraft.

### Electrosprays

#### a. Technology Description

Electrospray propulsion systems generate thrust by electrostatically extracting and accelerating ions or droplets from a low-vapor-pressure, electrically-conductive, liquid propellant (figure 4.22). This technology can be generally classified into the following types according to the propellant used:

**Ionic-Liquid Electrospays:** These technologies use ionic liquids (i.e., salts in a liquid phase at room conditions) as the propellant. The propellant is stored as a liquid, and onboard heaters may be present to maintain propellant properties within the desired operational temperature range. Commonly used propellants include 1-ethyl-3-methylimidazolium

tetrafluoroborate (EMI-BF<sub>4</sub>) and bis(trifluoromethylsulfonyl)imide (EMI-Im). Thrusters that principally emit droplets are also referred to as colloidal thrusters.

**Field Emission Electric Propulsion (FEEP):** These technologies use low-melting-point metals as the propellant. The propellant is typically stored as a solid, and onboard heaters are used to liquefy the propellant prior to thruster operations. Common propellants include indium and cesium.

Feed systems for electrospray technologies can be actively fed via pressurant gas or passively fed via capillary forces. The ion (high- $I_{SP}$ ) or droplet (moderate- $I_{SP}$ ) emission can be controlled by

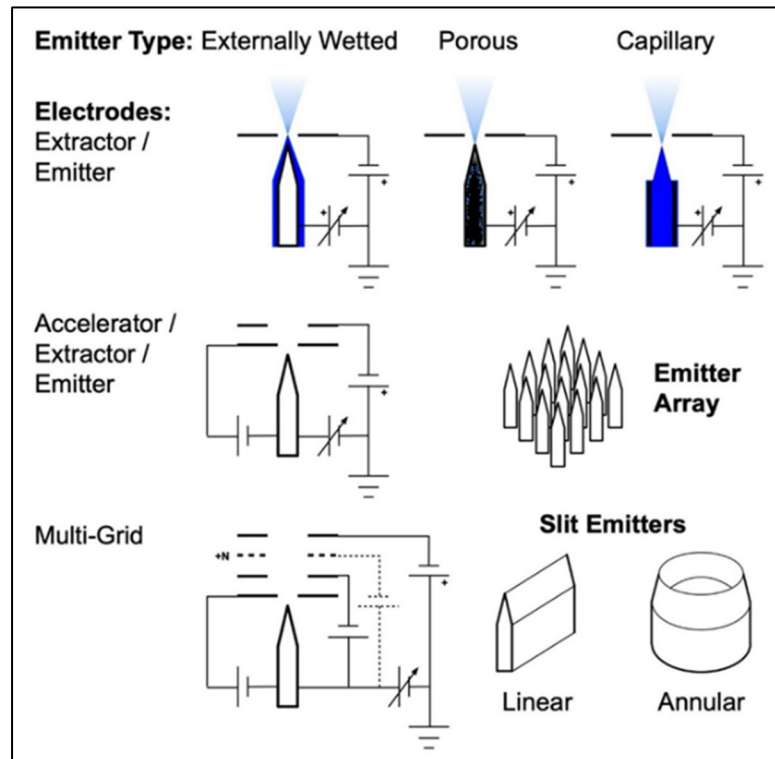


Figure 4.22: Schematic of typical electrospray emitter and electrode configurations. Credit: NASA.



modulation of the high-voltage (i.e., >1 kV) input in a closed-loop feedback system with current measurements. Stable operations in either emission mode can provide very precise impulse bits. Propellants that result in both anion and cation emission may not require the presence of a cathode neutralizer to maintain overall charge balance; such neutralizers are included as part of the electrospray propulsion system for propellants that only emit positively charged species.

#### b. Key Integration and Operational Considerations

- **Plume Contamination:** Because propellants for electrospray propulsion systems are electrically conductive and condensable as liquids or solids, impingement of the thruster plume on spacecraft surfaces may lead to electrical shorting and surface contamination of solar panels and sensitive spacecraft components.
- **Propellant Handling and Thruster Contamination:** Ionic liquids and metallic propellants can be sensitive to humidity and oxidation, so care is needed if extended storage prior to flight is required. Electrospray technologies can also be sensitive to contamination of the thruster head during propellant loading, ground testing (e.g., backspitter or outgassed materials from the test facility), and handling (i.e., foreign object debris). Precautions should be taken to minimize contamination risks from manufacturing, through test, and to launch. Post-launch, ionic liquids can outgas (e.g., water vapor) when exposed to the space environment, and such behavior should be accounted for in the mission ConOps.
- **Performance Stability and Lifetime:** As an electrospray propulsion system operates over time, the propulsive performance can degrade as the plume impinges upon and deposits condensable propellant on thruster head surfaces; in time, sufficiently deposited propellant buildup can electrically short out the thruster electrodes and terminate thruster operation. Especially for missions with large total impulse requirements, lifetime testing or validated life models of the electrospray propulsion system in a relevant environment is important for understanding end-of-life behavior.
- **Specific Impulse:** Even for electrosprays that principally emit ions, operational thruster modes and instabilities can result in droplet emission that degrade the specific impulse and thrust efficiency. Caution is advised when considering claimed specific impulse or other propulsive properties (e.g., thrust vector and beam divergence) derived from plume characteristics; verification test data in a relevant environment is important for properly assessing these claims.
- **Precision Thrust:** Electrospray devices have the potential of providing very fine thrust precision during continuous operations. For devices that can operate in pulsed mode via pulsed modulation of the high-voltage input, fine impulse bits (i.e., <10  $\mu\text{N}\cdot\text{s}$ ) may be achievable. Such operations can permit precise control over spacecraft attitude and maneuvering. Verification test data in a relevant environment should be used to properly assess the degree of thrust precision.

### c. Missions

The ESA Laser Interferometer Space Antenna (LISA) Pathfinder spacecraft was launched in December 2015, on Vega flight VV06. Onboard were two integrated propulsion modules associated with the NASA Space Technology 7 Disturbance Reduction System (ST7 DRS). Each propulsion module contained four independent Busek Colloid MicroNewton Thrusters (CMNT), propellant-less cathode neutralizers, power processing units, digital control electronics, and low-pressure propellant tanks. The propulsion system was successfully commissioned in-orbit in January 2016, after having been fully fueled and stored for almost eight years. The electro spray modules (figure 4.23), were operated at the Earth-Sun Lagrange Point 1 for 90 days to counteract solar disturbance forces on the spacecraft; seven of the eight thrusters demonstrated performance consistent with ground test results, and the full propulsion system met the mission-level performance requirements (143).

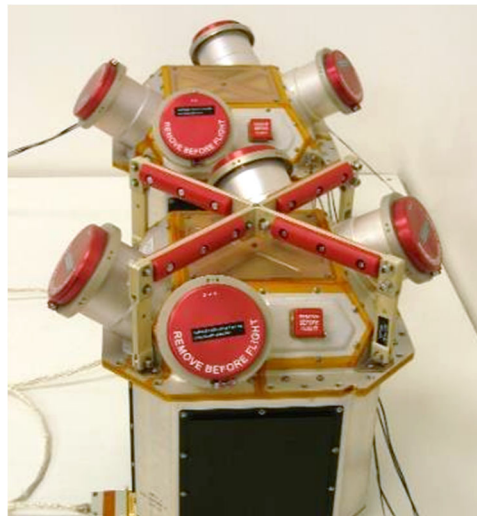


Figure 4.23: Flight CMNT modules for LISA Pathfinder. Credit: Busek.

Enpulsion's IFM Nano FEEP (figure 4.24), was first integrated onboard a 3U Planet Labs Flock 3P' CubeSat and launched via PSLV-C40 in January 2018. The indium-propellant propulsion system (with integrated thruster head, propellant storage, and power processing unit) was demonstrated in a 491 km by 510 km orbit. Two thruster firing sequences were reported, with the first a 15-minute firing in non-eclipse and the second a 30-minute firing in eclipse. Global Positioning System (GPS) telemetry data onboard the spacecraft indicated good agreement with the  $\sim 220 \mu\text{N}$  commanded thrust (144). Since this initial demonstration, the IFM Nano has flown onboard other spacecraft, but limited in-orbit data is publicly available. These missions include the ICEYE-X2 (launched onboard Falcon-9 flight F9-64 in December 2018) to provide low-Earth orbit interferometric synthetic aperture radar observations (145) (146) and the DOD-funded Harbinger technology demonstrator (launched onboard Electron flight STP-27RD in May 2019) (147) (148). The IFM Nano was also integrated onboard the Zentrum für Telematik (Würzburg) NetSat formation-flying demonstrator mission, which launched as a Soyuz-2 rideshare in September 2020 (149) (150). A summary of available on-orbit statistics, anomalies, and lessons learned for the Enpulsion Nano product line is available (151).



Figure 4.24: IFM Nano. Credit: Enpulsion.



Figure 4.25: IFM Micro R<sup>3</sup>. Credit: Enpulsion.

The GMS-T mission was launched in January 2021 onboard a Rocket Lab Electron. The telecommunications satellite uses an OHB Sweden Innosat platform and

houses an Enpulsion Micro R<sup>3</sup> (figure 4.25). Inaugural on-orbit commissioning of the propulsion system was confirmed in March 2021 (153).

The University Würzburg Experimental Satellite 4 (UWE-4) was launched as a secondary payload onboard the Soyuz Kanopus-V 5 and 6 mission in December 2018. This 1U spacecraft housed two Morpheus Space NanoFEEP systems, with each system consisting of two gallium-propellant thrusters, a power processing unit board for the UNISEC Europe bus, and a propellant-less cathode neutralizer. An experiment using one thruster as an attitude control actuator was reported, with the increased spacecraft rotation rate corresponding to a derived thrust magnitude of  $\sim 5 \mu\text{N}$ ; anomalous torque was attributed to unexpected impingement of the thruster plume upon the spacecraft antenna (154) (155). Orbit lowering capability was demonstrated in 2020; of the four individual thrusters, three experienced anomalous behavior during the UWE-4 mission (156). A 3U-Cubsat implementation of the same NanoFEEP technology is shown in figure 4.26.

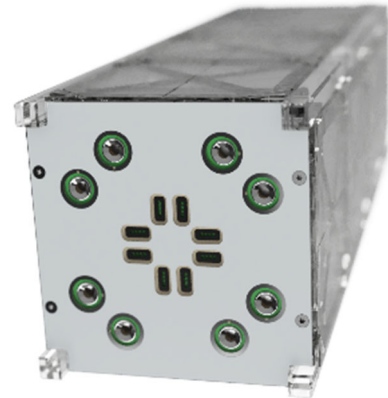


Figure 4.26: Eight NanoFEEP thrusters integrated on 3U-Cubesat bus. Credit: Morpheus Space.

Astro Digital's Tenzing satellite, which was integrated with a Sherpa-LTE Orbital Transfer Vehicle onboard the SpaceX Falcon 9 Transporter-2 launch in June 2021, housed two Accion Systems' TILE-2 units (figure 4.27) to demonstrate on-orbit rendezvous and proximity operations maneuvers (157). Another TILE-2 system is integrated onboard the Massachusetts Institute of Technology's BeaverCube, an educational mission launched as a secondary payload onboard the SpaceX CRS-25 mission in July 2022 (158).

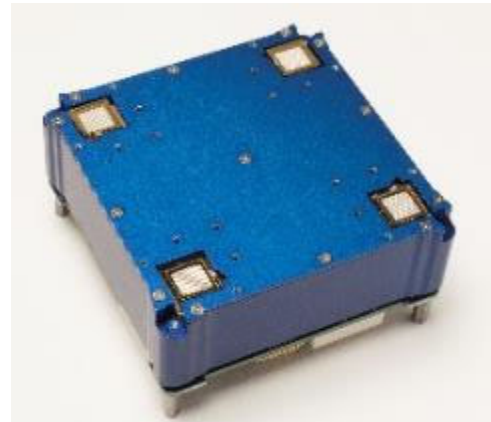


Figure 4.27: TILE-2. Credit: Accion Systems.

Accion's TILE-3 technology (consisting of an integrated unit with thruster heads, propellant storage, and power processing unit) was integrated onboard the D2/AtlaCom-1 mission. The spacecraft, a NanoAvionics M6P bus, was deployed in low-Earth orbit following a SpaceX Falcon 9 Transporter-2 launch in June 2021 (159). Under a NASA Tipping Point Partnership, this mission sought to use electrospray technology to demonstrate comparable propulsive capability as the MarCO CubeSats. Satellite GPS measurements indicated that some degree of attitude raising was achieved during thruster operations (160) (161). A TILE-3 unit is shown in figure 4.28.



Figure 4.28: TILE-3. Credit: Accion Systems.

#### d. Summary Table of Devices

See table 4-8 for current state-of-the-art electrospray devices applicable to small spacecraft.

## Gridded-Ion

### a. Technology Description

Gridded-ion propulsion systems ionize gaseous propellant via a plasma discharge, and the resultant ions are subsequently accelerated via electrostatic grids (i.e., ion optics). This technology can be generally classified into the following types according to the type of plasma discharge employed:

- **Direct-Current (DC) Discharge:** The propellant is ionized via electron bombardment from an internal discharge cathode (figure 4.29).
- **Radio-Frequency (RF) Discharge:** No internal discharge cathode is present. Instead, the propellant is ionized via RF or microwave excitation from an RF generator (figure 4.30).

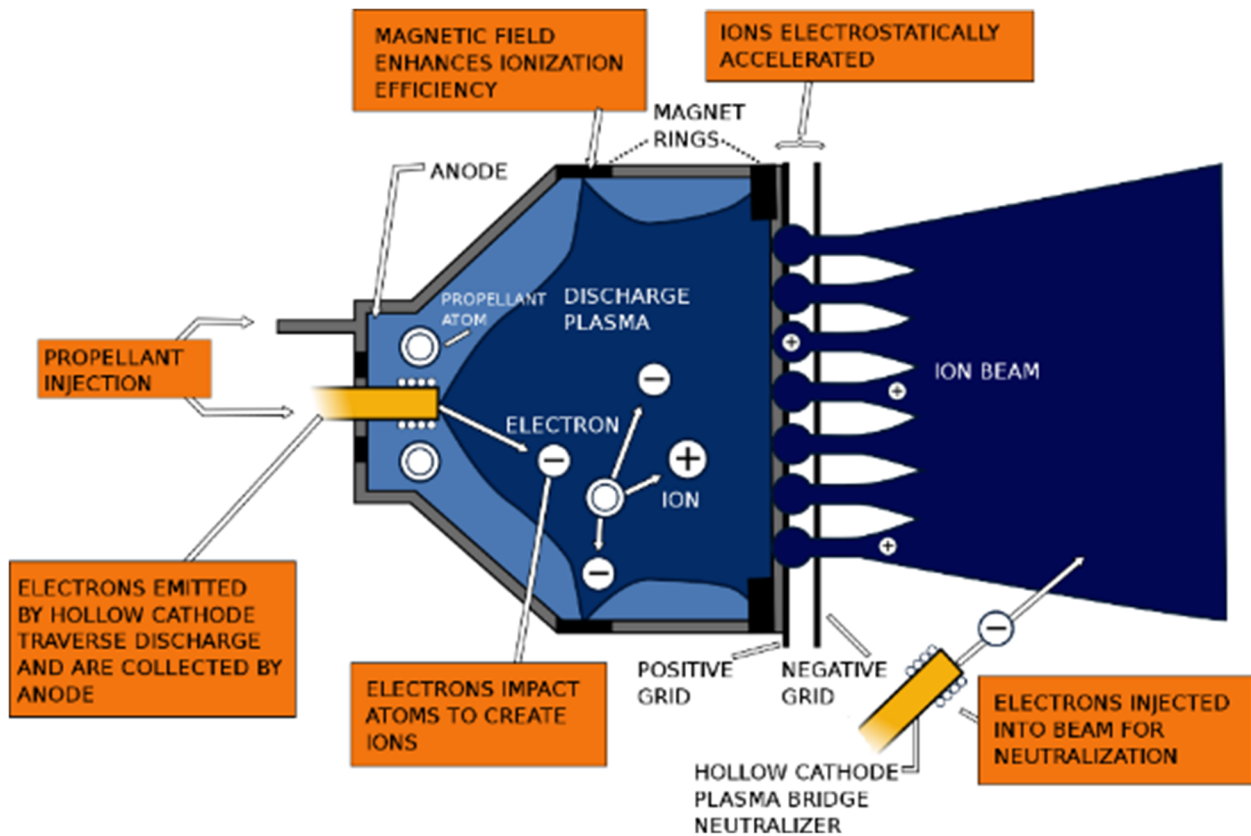


Figure 4.29: Schematic of typical DC-discharge gridded-ion thruster. Credit: NASA.

Gridded-ion thrusters typically operate at high voltages and include an external neutralizer cathode to maintain plume charge neutrality. High specific impulses can be achieved, but the thrust density is fundamentally limited by space-charge effects. While the earliest thruster technologies used metallic propellants (i.e., mercury and cesium), modern gridded-ion thrusters use noble gases (e.g., xenon) or iodine.

### b. Key Integration and Operational Considerations

- **Performance Prediction:** Due to the enclosed region of ion generation and acceleration, gridded ion thrusters tend to be less sensitive to test-facility backpressure effects than other devices such as Hall thrusters. This allows for more reliable prediction of in-flight performance based on ground measurements. Furthermore, the separation between ion

generation and acceleration mechanisms within the device tend to make calculations of thrust and ion velocity (or  $I_{SP}$ ) more straightforward.

- **Grid Erosion:** Charge-exchange ions formed in between and downstream of the ion optics can impinge upon and erode the grids. Over time, this erosion can lead to a variety of failure modes, including grid structural failure, an inability to prevent electrons from back streaming into the discharge chamber, or the generation of an inter-grid electrical short due to the deposition of electrically conductive grid material. Proper grid alignment must be maintained during thruster assembly, transport, launch, and operations to minimize grid erosion. Random vibration tests at the protoflight level should be conducted to verify the survivability of the ion optics against launch loads, and validated thermal modeling may be needed to assess the impact of grid thermal expansion during thruster operations.
- **Foreign Object Debris:** The grids are separated by a small gap, typically less than 1 mm, to maximize the electric field and thrust capability of the device. As a result, gridded-ion thrusters tend to be sensitive to foreign object debris, which can bridge the inter-grid gap and cause electrical shorting. Precautions should be taken to minimize such contamination risks from manufacturing, through test, and to launch.
- **Cathode Lifetime:** Cathodes for plasma discharge or plume neutralization may be sensitive to propellant purity and pre-launch environmental exposure. Feed system cleanliness, bake-out, and use of a high-purity propellant are key factors in maximizing cathode lifetime. The technology provider may recommend maximum cumulative atmospheric exposure and humidity to reduce risk.
- **Roll Torque:** Misalignments in the ion optics can lead to disturbances in the thrust vector, resulting in a torque around the roll axis that cannot be addressed by the mounting gimbal.

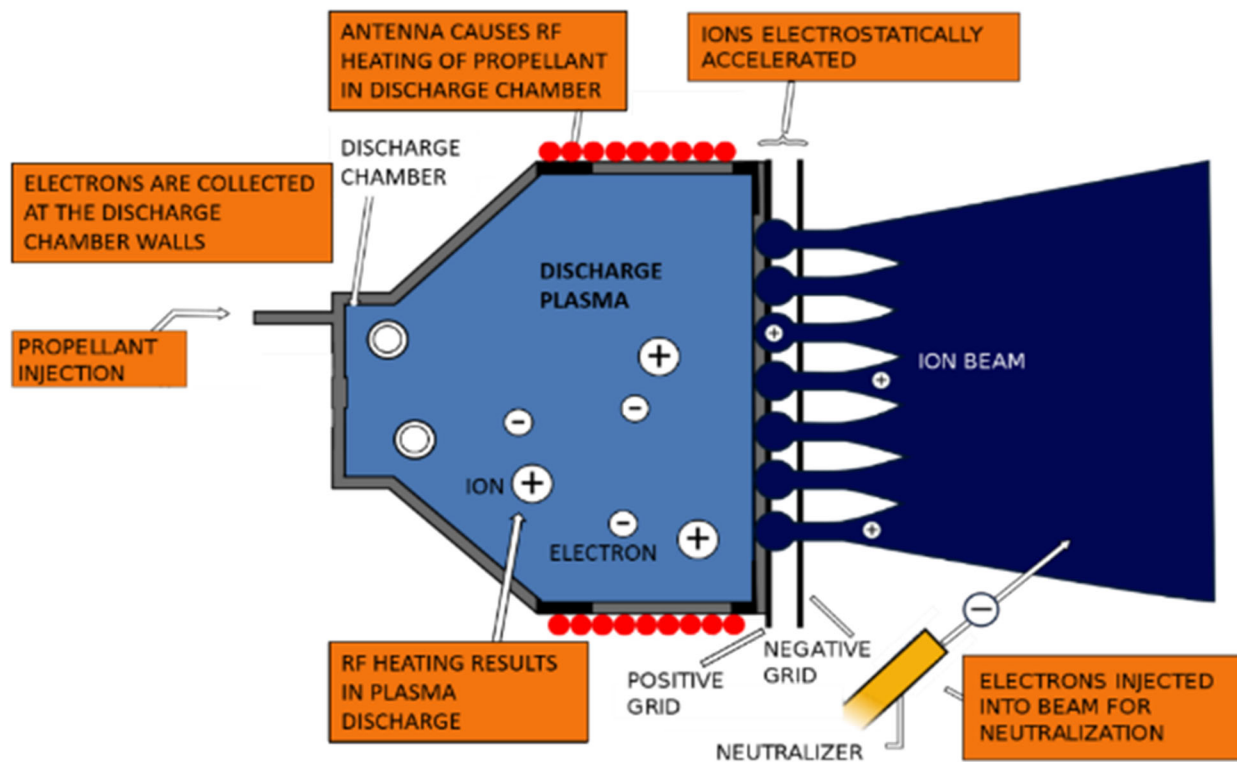


Figure 4.30: Schematic of typical RF-discharge gridded-ion thruster. Credit: NASA.



For missions requiring extended thruster operations, a secondary propulsion system or reaction wheels may be needed to counter the torque buildup (162).

- **Electromagnetic Interactions:** For RF-discharge thrusters, electromagnetic interference and compatibility (EMI/EMC) testing may be critical to assess the impact of thruster operations on spacecraft communications and payload functionality.
- **Iodine Propellant:** To address the volume constraints of small spacecraft, iodine is an attractive propellant. Compared to xenon, iodine's storage density is three times greater. Furthermore, iodine stores as a solid with a low vapor pressure, which addresses spacecraft integration concerns associated with high-pressure propellant storage. However, iodine is a strong oxidizer, and long-duration impact on the thruster and spacecraft remain largely unknown. Upcoming flights will provide insight into potential spacecraft interactions and long-term reliability of feed system and thruster components.
- **Power Electronics:** Operation of gridded-ion thrusters requires multiple high-voltage power supplies for discharge operation (ion generation), ion acceleration, and neutralization, leading to potentially complex and expensive power electronics.

### c. Missions

The ESA Gravity Field and Steady-State Ocean Circulation Explorer (GOCE) was launched in March 2009 onboard a Rokot / Briz-KM to provide detailed mapping of Earth's gravitational field and ocean dynamics from an altitude of ~220-260 km. Two QinetiQ T5 DC-discharge gridded-ion thrusters (figure 4.31), with one serving as a redundant backup, successfully provided drag-free control of the 1000-kg satellite until xenon propellant exhaustion in October 2013 (163) (164).



Figure 4.31: T5 gridded-ion thruster for GOCE mission. Credit: QinetiQ.

The Beihangkongshi-1 satellite was launched in November 2020 onboard a Long March 6 rocket. The 12U Spacety CubeSat housed a ThrustMe NPT30-I2-1U (figure 4.32), a 1U-integrated, RF-discharge gridded-ion propulsion system. As part of the first on-orbit demonstration of iodine-propellant electric propulsion, two 90-minute burns provided an orbit altitude change of 700 m (165). A 1.5U version of the NPT30-I2 is expected to fly onboard a Space Flight Laboratory of the University of Toronto, Institute for Aerospace Studies (UTIAS) 35-kg DEFIANT bus for the Norwegian Space Agency's NorSat-TD mission; expected to launch in 2023, this mission includes a demonstration of satellite collision avoidance maneuvers (166). NPT30-I2-1.5U is also expected to fly onboard a GomSpace 12U CubeSat for the 2022 ESA GOMX-5 technology demonstration mission (167).



Figure 4.32: NPT30-I2-1U. Credit: ThrustMe.

Lunar IceCube is an upcoming NASA-funded CubeSat mission to characterize the distribution of water and other volatiles on the Moon from a highly-inclined lunar orbit with a perilune < 100 km. Led by Morehead State University, the mission will be conducted via a 6U spacecraft as a secondary payload onboard Artemis I (168) (169).

Lunar Polar Hydrogen Mapper (LunaH-Map) is an upcoming NASA-funded CubeSat mission to map hydrogen distributions at the lunar south pole from a lunar orbit with a perilune < 20 km. Led by Arizona State University, the mission will be conducted via a 6U spacecraft as a secondary payload onboard Artemis I (170).

Both Lunar IceCube and LunarH-Map missions use an onboard Busek BIT-3 propulsion system (figure 4.33) with solid iodine propellant. The BIT-3 system will be used as primary propulsion during the lunar transfer trajectory, followed by lunar orbit capture, orbit lowering, and spacecraft disposal. Each integrated BIT-3 system includes a low-pressure propellant tank with heated propellant-feed components, a power processing unit to control the RF thruster and RF cathode, and a two-axis gimbal assembly.

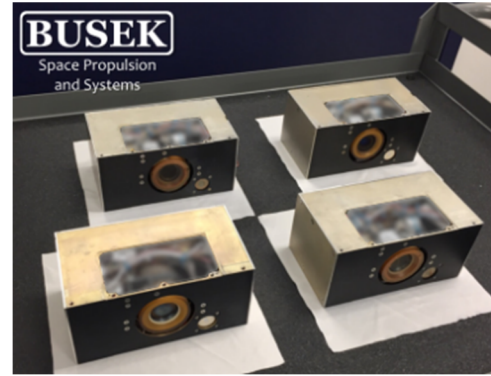


Figure 4.33: BIT-3 thruster. Credit: Busek.

#### d. Summary Table of Devices

See table 4-9 for current state-of-the-art gridded-ion devices applicable to small spacecraft.

### Hall-Effect

#### a. Technology Description

The Hall-effect thruster (HET) is arguably the most successful in-space EP technology by quantity of units flown. The Soviet Union first flew a pair of EDB Fakel SPT-60 HETs on the Meteor-1-10 spacecraft in 1971. Between 1971 and 2018, over 300 additional HETs flew internationally, although EDB Fakel produced the vast majority. The first flight of a non-Russian HET was on board the European Space Agency (ESA) Small Missions for Advanced Research in Technology (SMART-1) spacecraft in 2003. SMART-1 employed the French PPS-1350 HET, produced by Safran (171). The first flight of a U.S. manufactured HET, the Busek BHT-200, was onboard the TacSat-2 spacecraft (172), a U.S. Air Force Research Laboratory (AFRL) experimental satellite in 2006. In 2010, Aerojet, another U.S. entity, began commercially delivering their 4.5 kW XR5 HET (173), formerly BPT-4000. Launches of HETs greatly accelerated in 2019 with the launch of 120 SpaceX Starlink and 6 OneWeb spacecraft (174), each using an HET. As of September 2022, SpaceX has launched over 3,000 Starlink satellites, and OneWeb has launched over 400 satellites. Suffice to say that HETs have become a mainstream in-space propulsion technology.

The rapid growth in demand for HETs can be attributed to their simple design, historically well-demonstrated reliability, good efficiency, high specific impulse, and high thrust-to-power ratio. Although, the higher voltage gridded-ion thrusters (GIT) can achieve even higher specific impulse, HETs can achieve higher thrust-to-power ratios because the HET's higher density quasi-neutral plasma is not subject to space-charge limitations. The HET's higher thrust-to-power ratio will typically shorten spacecraft transit time. On the other end of the spectrum, arcjets provide significantly higher thrust than HETs, however material limitations prevent arcjets from matching the HET's electrical efficiency and specific impulse. For many missions, HETs provide a good balance of specific impulse, thrust, cost, and reliability.

HETs are a form of ion propulsion, ionizing and electrostatically accelerating the propellant. Historically, all HETs flown in space have relied on xenon propellant, given its high molecular weight, low ionization energy, and ease of handling. The recent exception is the SpaceX Starlink spacecraft using krypton propellant. While HETs typically operate less efficiently with krypton propellant, and krypton has more challenging storage requirements, krypton gas is considerably lower cost than xenon gas. Lower cost is a compelling attribute when the potential number of spacecrafts are projected in the thousands, as with constellations. Many other propellants have been considered and ground tested for Hall-effect thrusters, but to date only Hall-effect thrusters using xenon or krypton have flown.

As schematically shown in figure 4.34, HETs apply a strong axial electric field and radial magnetic field near the discharge chamber exit plane. The  $\mathbf{E} \times \mathbf{B}$  force greatly slows the mean axial velocity of electrons and results in an azimuthal electron current many times greater than the beam current. This azimuthal current provides the means by which the incoming neutral propellant is collisionally ionized. These ions are electrostatically accelerated and only weakly affected by the magnetic field. The electron source is a low work function material typically housed in a refractory metal structure (i.e., hollow cathode), historically located external to the HET body. Many recent thruster designs have begun centrally mounting the cathode in the HET body as shown in figure 4.34. The cathode feeds electrons to the HET plasma and neutralizes the plasma plume ejected from the thruster. The high voltage annular anode sits at the rear of the discharge chamber and typically functions as the propellant distribution manifold.

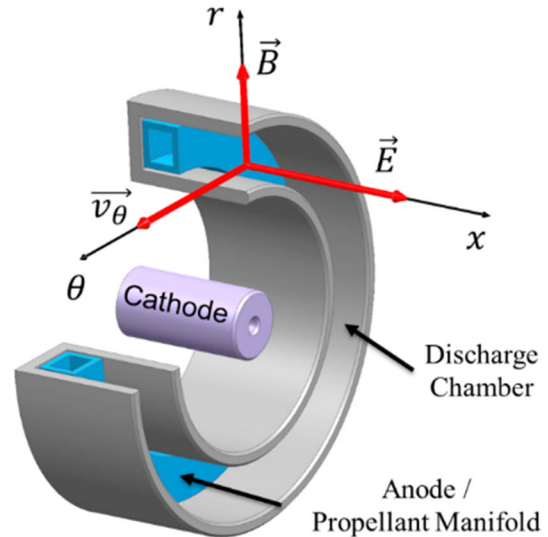


Figure 4.34: Hall-effect Thruster schematic. Credit: NASA.

#### b. Key Integration and Operational Considerations

- **Ground Facility Effects:** Ground facility effects may result in inconsistencies between ground and flight performance. The significance of the inconsistencies depends on factors such as test facility scale, test facility pumping speed, intrusiveness of diagnostics, and thruster electrical configuration.
- **Contamination:** Plume ions of an HET can affect spacecraft surfaces by erosion or contamination, even at large plume angles. Ground facility measurement of ion density at large angles may under predict flight conditions.
- **Thermal Soak-Back:** HET core temperature may exceed 400°C with the cathode exceeding 1000°C. Most HET waste heat radiates directly from the HET surfaces. However, some thermal soak-back to the spacecraft will occur through the mounting structure, propellant feed lines, electrical harness, and radiation.
- **Survival Heaters:** Given the thermal isolation between the HET and spacecraft, the HET may require a survival heater depending on the qualification temperature and flight environments.
- **Performance:** HET performance may vary over the life of the device due to erosion and contamination of the plasma wetted HET surfaces. Magnetically shielded thrusters demonstrate less time dependency to their performance than classical HETs.



- **Thruster Lifetime:** Classical HETs are primarily life-limited by erosion of the discharge chamber wall. Magnetically shielded HETs are primarily life-limited by erosion of the front pole covers.
- **Cathode Lifetime:** Cathode lifetime may be sensitive to propellant purity and pre-launch environmental exposure. Feed system cleanliness, bake-out, and use of a high purity propellant are key factors in maximizing cathode lifetime. The HET manufacturer may recommend a maximum cumulative atmospheric exposure and humidity. Some cathode emitter formulations are less sensitive to propellant impurities and atmospheric exposure, but these formulations may require other trades such as a higher operating temperature.
- **Roll Torque:** The  $\mathbf{E} \times \mathbf{B}$  force results in a slight swirl torque. For missions requiring extended thruster operations, a secondary propulsion system or reaction wheels may be needed to counter the torque buildup. The roll torque may largely be countered by periodically reversing the direction of the magnetic field. Field reversal requires switching the polarity of current to the magnet coils. Field reversal is only possible with HETs using electromagnets.
- **Thrust Vector:** Non-uniformity of the azimuthal plasma, magnetic field, or propellant flow may result in slight variations of the thrust vector relative to the HET physical centerline. Temperature variation of the HET, such as during startup, may result in a slight walking of the thrust vector.
- **Heaterless Cathodes:** Heaterless cathode technologies continue to mature. The benefit of a heaterless cathode is elimination of the cathode heater, typically an expensive component due to rigorous manufacturing and acceptance processes. However, the physics of heaterless cathode life-limiting processes require further understanding. Nevertheless, heaterless cathode demonstrations have empirically shown significant promise. Heaterless cathode requirements on the EP system differ from an HET with a cathode heater. Impacts on the power processing unit and feed system should be well understood when trading a heaterless versus heated cathode.
- **Throttling Range:** HETs typically throttle stably over a wide range of power and discharge voltage. This makes an HET attractive for missions requiring multiple throttle set-points. However, an HET operates most efficiently at specific throttle conditions. Operating at off-nominal conditions may result in decreased specific impulse and/or electrical efficiency.

### c. Missions

Canopus-V (or Kanopus-V) is a Russian Space Agency spacecraft for Earth observation with a design life of 5 years. The 450 kg spacecraft launched in 2012 employed a pair of EDB Fakel SPT-50 thrusters. Similarly, the Canopus-V-IK (Kanopus-V-IK) launched in 2017 with a pair of SPT-50. The SPT-50 thrusters have a long history of spaceflight dating back to the late 1970s. Although the Canopus bus exceeds 450 kg, the power class and physical scale of the SPT-50 are appropriate for smaller spacecraft. The SPT-50 is nominally a 220 W thruster operated on xenon propellant (175) (176) (177).

The KazSat-1 and KazSat-2 spacecraft produced by Khrunichev Space Center in cooperation with Thales Alenia Space launched in 2006 and 2011, respectively. The KazSat spacecraft are geosynchronous communication satellites. These spacecrafts employ the EDB Fakel SPT-70BR thruster. The SPT-70BR is Fakel's latest version of the SPT-70 product line. EDB Fakel optimized the SPT-70 for operation between 600 and 700 W, but no more than 900 W. Experiments demonstrate a lifetime of 3,100 hours, equating to about 450 kNs. The SPT-70 thrusters have a long history of spaceflight dating back to the early 1980s. Control of KazSat-1 was lost in 2008 (178) (179).

The Busek BHT-200 (figure 4.35) has the distinction of being the first U.S.-made HET to operate in space. The BHT-200 has flight heritage from demonstrations on the TacSat-2 mission launched in 2006, FalconSat-5 mission launched in 2010, and FalconSat-6 mission launched in 2018. A Busek PPU powered the 200 W HET for each of the FalconSat missions (180). Ground testing of the BHT-200 includes multiple propellants, although all spaceflights have used xenon. Busek developed an iodine compatible derivative of the BHT-200 for the NASA iSat mission. It was determined during the course of the iSat project that additional development related to iodine compatible cathodes was required before conducting an in-space demonstration of the technology (181) (184).



Figure 4.35: BHT-200 thruster. Credit: Busek.

The Israel Space Agency and the French National Center for Space Studies (CNES) jointly developed the Vegetation and Environment monitoring on a New Microsatellite (VENuS) spacecraft launched in 2017. The 268 kg VENuS spacecraft includes a pair of Rafael IHET-300 thrusters (figure 4.36) and 16 kg of xenon propellant. Inflight operations have demonstrated operation between 250 and 600 W. Rafael developed the IHET-300, nominally operating at 300 W, specifically for small spacecraft (185) (188) (189) (190) (191).



Figure 4.36: IHET-300 thruster. Credit: Rafael.

The European and Italian space agencies selected the SITAEL HT100 (figure 4.37) for an in-orbit validation program to evaluate the device's capabilities for orbital maintenance and accelerated reentry of a small spacecraft. The uHETSat mission will be the first in-orbit demonstration of the HT100. SITAEL is currently performing ground qualification of the complete propulsion system. The HT100 is nominally a 175 W device operating on xenon propellant. The uHETSat will use the SITAEL S-75 microsatellite platform. The S-75 is 75 kg with dimensions of 60 x 40 x 36 cm<sup>3</sup>. The anticipated launch date targets 2022 (193) (194) (195).

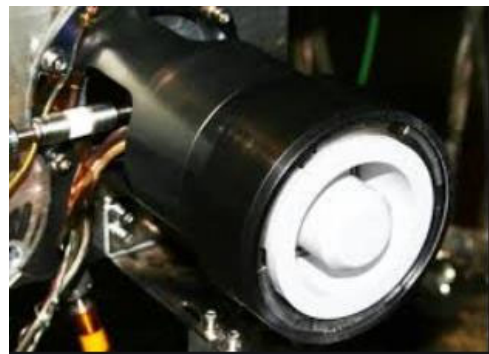


Figure 4.37: HT100 thruster. Credit: SITAEL.

The Astra Spacecraft Engine (ASE), figure 4.38, successfully achieved orbital ignition onboard the Spaceflight Sherpa-LTE1 orbital transfer vehicle, which launched from SpaceX's Transporter-2 mission on June 30, 2021 (196). This single-string system is sized to achieve a controlled de-orbit of Sherpa-LTE1 (198). On-orbit performance was demonstrated by operating the system for 5-minute durations. The first 54 maneuvers have been reported (197). After outgassing, performance metrics were nominal within one standard deviation of ground test data. On-orbit thrust averaged 22.4 mN, and specific impulse for each 5-minute thrust maneuver averaged 1108 seconds. Total propulsion system power processing efficiency averaged 94%, including feed system power, circuit efficiency, and housekeeping circuits. As of October 2022, the ASE aboard the Sherpa-LTE1 is continuing mission operations and has operated for more than 300 five-minute maneuvers (i.e., accumulated total duration of 25 hours). The ASE, (formerly the Apollo Constellation Engine) is a propulsion system that was acquired in Astra's purchase of Apollo

Fusion in 2021. The ASE is designed for operation with xenon and krypton propellants and sized to fit ESPA-class missions. The propulsion system includes several key technologies, including permanent magnets, a heatless instant start cathode, and a radiation hardened PPU. Astra has also reportedly sold ASE units to OneWeb (199) and LeoStella (200).

Exotrail launched its first in-orbit demonstration mission including the 50 Watt ExoMG-nano (figure 4.39) thruster in November 2020. NanoAvionics and Exotrail partnered to integrate the ExoMG-nano into NanoAvionics' M6P nanosatellite 6U bus. Exotrail and its partners designed, built, integrated, and qualified the ExoMG-nano demonstrator in 10 months. Exotrail further signed a contract with AAC Clyde Space to provide propulsion for the Eutelsat ELO 3 and ELO4 6U CubeSats anticipated to launch in 2022 and 2023, respectively (201) (202) (203) (204) (205). Exotrail further provided its ExoMG-nano for the AerospaceLab's Risk Reduction Flight (RRF) mission. The AerospaceLab spacecraft, known as "Arthur," was launched in 2021. The propulsion system will be used to demonstrate the spacecraft maneuver capabilities (206) (207).

An ExoMG™ - micro cluster<sup>2</sup> will be integrated onboard York Space Systems S-Class platform for a satellite mission aiming to orbit the Moon and deliver Earth-to-Moon telecommunication services in support of Intuitive Machines' lunar south pole mission scheduled for launch in late 2022. With ExoMG™- cluster<sup>2</sup>, York Space Systems will be able to execute maneuvers such as a lunar transfer orbit (208). Additionally, Exotrail will launch its SpaceVan™ In-Orbit Demonstration (IOD) mission in October 2023. The SpaceVan™ uses Exotrail's ExoMG™ - micro cluster<sup>2</sup> to demonstrate its capabilities (e.g., plane change maneuvers or altitude change) (210).

Blue Canyon, a Raytheon subsidiary, is producing satellites for the DARPA Blackjack program. Blue Canyon selected Exoterra's Halo thruster (figure 4.40), for its Phase 2 and Phase 3 satellites (216). Exoterra expects Halo to fly on two Blackjack missions anticipated to launch in 2022. These will be the first flights of ExoTerra's Halo electric propulsion system. Additionally, ExoTerra has received a NASA Tipping Point award to perform an in-orbit demonstration of their 12U Courier SEP spacecraft bus, tentatively planned for launch in 2024. The bus includes ExoTerra's Halo thruster, xenon flow control system (XFC), power processing unit (PPU), and deployable solar arrays. The Courier spacecraft



Figure 4.38: Astra Spacecraft Engine (ASE). Credit: Astra.



Figure 4.39: ExoMG-nano thruster. Credit: Exotrail.



Figure 4.40: Halo thruster. Credit: ExoTerra Resource.

provides up to 1 km/s of delta-v, while hosting a 2U, 4 kg payload. The Tipping Point mission objective is to demonstrate the SEP system by spiraling to 800 km from a drop-off orbit of 400 km and then deorbiting. Primary mission objectives include demonstration of the solar array deployment and power generation, PPU efficiency, and 2 kg of thruster propellant throughput. For the Tipping Point mission, the 0.85 kg, 1/3U thruster will nominally operate at 135 W discharge power and produce ~8 mN of thrust (211) (212) (213) (214) (215).

AST & Science (AST) of Midland, Texas, selected the Aurora Hall-Effect Propulsion System (figure 4.41) manufactured by Orbion Space Technology for its SpaceMobile network. AST anticipates SpaceMobile to be a low-Earth orbit constellation of hundreds of satellites providing cellular coverage for 4G and 5G smartphones. Orbion's Aurora thrusters will provide propulsion for orbital maintenance, collision avoidance, and de-orbiting at end-of-life. Orbion's Aurora propulsion system consists of a thruster, cathode, power processing unit, propellant flow controller, and cable harness. The anticipated launch date for the first satellite of the SpaceMobile constellation is March 2022 (223) (224) (225).

Blue Canyon has selected the Orbion Aurora thruster for DARPA Blackjack satellites. Blue Canyon is producing four satellites for the DARPA program as one of multiple satellite bus suppliers. Blackjack satellites are about 150 kilograms (226).

Orbion's Aurora Hall-effect thruster system was selected for a U.S. Space Force 400-kg prototype weather satellite, under contract with General Atomics Electromagnetic Systems (GA-EMS). The Aurora thruster will be used for orbit raising, orbit maintenance, and de-orbit over the 3-5 year mission (227).

Busek has supplied its BHT-350, figure 4.42, Hall-effect thruster to Airbus OneWeb Satellites (AOS) for a range of missions. Busek engineered and qualified the thrusters for orbit raising, orbit maintenance, and end-of-life de-orbit. The thruster has a demonstrated total impulse capability of 212 kN-s (182) (183).

Busek shipped its first flight BHT-600 Hall-effect thruster system to a U.S. Government customer in early 2021 for an anticipated flight in 2021. The BHT-600 previously demonstrated a 7,000-hour ground test performed at NASA GRC as part of a NASA Announcement for Collaborative Opportunity (ACO) Space Act Agreement (SAA), figure 4.43. The thruster successfully



Figure 4.41: Two flight Aurora HETs undergoing qualification testing. Credit: Orbion Space Technology.



Figure 4.42: BHT-350 Flight Units. Credit: Busek Co.

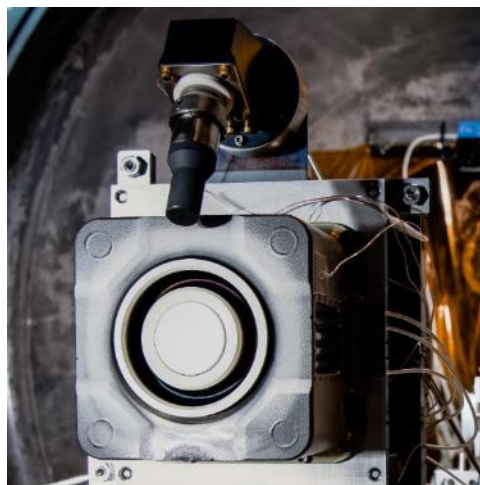


Figure 4.43: BHT-600 Installed in NASA GRC Vacuum Test Facility. Credit: Busek Co.

demonstrated 70 kilograms of xenon propellant throughput before the test was terminated. The BHT-600 is designed for operation from 400 W to 1 kW (228) (229).

Northrop Grumman's (NG) Tactical Space Systems Division has developed the NGHT-1X (figure 4.44) Hall-effect thruster for its next generation satellite servicing vehicle known as the Mission Extension Vehicle (MEP). MEP carries power and propulsion for client vehicle station keeping and momentum management. Furthermore, MEP uses its propulsion system to propel itself from launch vehicle injection into an orbit near the client vehicle, where an NG Mission Robotic Vehicle (MRV) installs the MEP on the client vehicle. MEP is designed for a 6-year mission life but can carry a propellant load that permits even longer lifetimes. Each thruster is designed to generate a total impulse of 2.1 MN-s, not including margin, to enable the MEP mission. NG partnered with the NASA Glenn Research Center (GRC) to develop and commercialize the NGHT-1X, licensing NASA's technology for a high propellant throughput, sub-kilowatt hall-effect thruster. NG's SpaceLogistics sold its first MEP to Australian satellite operator Optus for its D3 satellite. SpaceLogistics signed a launch agreement with SpaceX for a planned spring 2024 launch (219) (220) (221) (222).

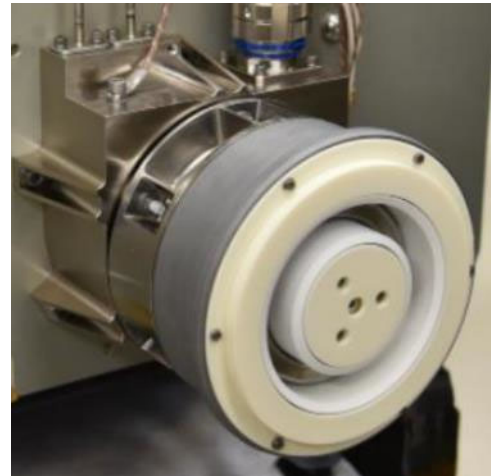


Figure 4.44: NGHT-1X Engineering Model Hall-Effect Thruster. Credit: Northrop Grumman.

#### d. Summary Table of Devices

See table 4-10 for current state-of-the-art HET devices applicable to small spacecraft.

### Pulsed Plasma and Vacuum Arc Thrusters

#### a. Technology Description

Pulsed Plasma Thrusters (PPT) produce thrust by triggering an electric arc between a pair of electrodes that typically ablates a solid-state propellant like polytetrafluoroethylene (PTFE) or ionizes a gaseous propellant. The plasma may be accelerated by either electrothermal or electromagnetic forces. Whether the mechanism of acceleration is electrothermal, electromagnetic, or often some combination thereof, is determined by the device topology (230).

Electrothermal PPTs characteristically include a chamber formed by a pair of electrodes and solid propellant, wherein propellant ablation and heating occurs. During and immediately following each electric discharge, pressure accumulates and accelerates the propellant through a single opening. Electromagnetic PPTs characteristically do not highly confine the propellant as plasma forms. The current pulse, which may exceed tens of thousands of amps, highly ionizes the ablated material or gas. The current pulse further establishes a magnetic field, where the  $\mathbf{j} \times \mathbf{B}$  force accelerates the plasma. PPT devices that are predominantly electrothermal typically offer higher thrust, while devices that are predominantly electromagnetic offer higher specific impulse.

The simplest PPTs have no moving parts, which may provide a high degree of reliability. However, as the solid propellant is consumed, the profile of the propellant surfaces is constantly changing. Thus, PPTs with static solid propellant demonstrate a change in performance over their life and inherently have a relatively limited lifetime. More complex solid propellant PPTs include a propellant feed mechanism. Typically, the propellant surface profile changes during an initial burn-in period, but then settles into a steady-state behavior where the propellant advancement is balanced by the propellant ablation.





PPT devices are suitable for attitude control and precision pointing applications. PPTs offer small and repeatable impulse bits, which allow for very high precision maneuvering. The complete propulsion system consists of a thruster, an ignitor, and a power processing unit (PPU). Energy to form the pulsed discharge is stored in a high voltage capacitor bank, which often accounts for a significant portion of the system mass. Once the capacitors are charged, resulting in a large differential voltage between the electrodes, the ignitor provides seed material that allows the discharge between the electrodes to form. Various materials and gases (including water vapor) have been tested with PPTs, however PTFE remains most common.

Vacuum arc thrusters (VAT) are another type of pulsed plasma propulsion (231). This technology consists of two metallic electrodes separated by a dielectric insulator. Unlike PPTs, one VAT electrode is sacrificial, providing the propellant source. The mechanism for propellant acceleration is predominantly electromagnetic, resulting in a characteristically high specific impulse and low thrust. One variant of the VAT is predominantly electrostatic, by the inclusion of a downstream electrostatic grid.

#### b. Key Integration and Operational Considerations

- **Safety:** PPT capacitor banks often store tens of joules of energy at potentially a couple thousand volts. Follow good electrical safety practices when operating and storing PPTs in a laboratory environment.
- **Input Power Range:** PPTs and VATs are pulsed devices, which operate by discharging energy stored in capacitors with each pulse. Thus, the propulsion system's average power draw from the spacecraft bus can be quite low or high depending on the capacitor energy storage and pulse frequency. This flexibility allows PPTs to be applied to spacecraft with limited power budgets of just a few watts, or ample power budgets of hundreds of watts.
- **Minimum Impulse Bit:** A compelling capability of pulsed devices is the ability to generate small, precise, and well-timed impulse bits for precise spacecraft maneuvering. By controlling the discharge voltage, very small impulse bits on the order of micronewton-seconds are easily achieved.
- **Compact and Simple Designs:** PPTs and VATs are typically very simple and compact devices. While the total impulse capability is small compared to other forms of EP, these devices offer a particularly attractive solution for CubeSats, where low cost may be a more significant consideration than total impulse. The systems are also attractive for learning environments where propulsion expertise such as high-pressure feed systems and propellant management may be lacking.
- **Late-Time Ablation:** Although pulsed devices allow for operation over a wide range of pulse frequency, thruster efficiency typically improves with higher pulse rate. Late time ablation is a key inefficiency of solid propellant pulsed devices, where material continues to ablate from the propellant surface well after the discharge pulse. The amount of material accelerated may be maximized through higher frequency pulsing.
- **Thrust-to-Power:** Pulsed devices suffer from several inefficiencies including late time ablation, frozen flow, and wall heating. Propulsion system efficiency is typically below 20% and may be as low as a few percent. Thus, although pulsed devices may have high specific impulse, the thrust-to-power is low. Small spacecraft with limited power for propulsion may find that large propellant loads provide little benefit as there is inherently a limitation to the number of pulses achievable over the life of the power-limited spacecraft.
- **Thermal Soak-back:** The low thruster efficiencies may result in large thermal loads on the spacecraft due to thermal soak-back, especially at high rates of pulsing. The spacecraft's ability to radiate this energy to limit heating may set an upper bound on pulse frequency.

- **Ignitor:** Pulsed devices usually require some form of ignitor to provide seed material to lower the impedance between the electrodes and initiate the discharge pulse. As such, the lifetime of the ignitor may drive the lifetime of the thruster. Ignitors may fail due to erosion or fouling that prevents sparking. Some devices may include multiple redundant ignitors to increase system lifetime.
- **Shorting:** The electrodes of pulsed devices are separated by isolating elements. Shadow shielding or other physical features are typically necessary to avoid shorting between electrodes as conductive material ejected by the thruster accumulates. While PTFE is an insulator, the PTFE is reduced to carbon and fluorine when ablated, where carbon accumulation provides a potentially conductive path. VATs employ metal propellants that can similarly result in unintended shorting.
- **Spacecraft Contamination:** As with any conductive propellant, contamination of the spacecraft is a concern. Plume interaction with the spacecraft must be understood to assess the impact of the plume on the operation of critical surfaces such as solar panels, antennas, and radiators.

### c. Missions

In 2019, CU Aerospace was selected for a NASA STMD Tipping Point award to design, fabricate, integrate, and perform mission operations for the DUPLEX 6U CubeSat having two of CU Aerospace's micro-propulsion systems onboard, one Monofilament Vaporization Propulsion (MVP) system (129) (130) (131), shown in figure 4.19, and one Fiber-Fed Pulsed Plasma Thruster (FPPT) system (132) (133) (134) (135) (136), shown in figure 4.45. The FPPT can provide a large total impulse primary propulsion for micro-satellites through implementation of a novel PTFE fiber propellant storage and delivery mechanism. A major enhancement of the FPPT technology over classical PPTs is the ability to control both the propellant feed rate and pulse energy, thereby providing control of both the specific impulse and thrust. The FPPT can also provide precision control capability for small spacecraft requiring capabilities such as precision pointing or formation flying. Thrust-vectoring capability of  $\pm 10^\circ$  in the yaw and pitch axes (also with the potential for roll control authority) has been incorporated into the system allowing for wheel desaturation for deep space missions. In-orbit Duplex operations will include inclination change, orbit raising and lowering, drag makeup, collision avoidance, thrust vectoring, and deorbit burns demonstrating multiple mission capabilities with approximately 17 hours of operation for MVP and >20,000 hours for FPPT. Launch is manifested in early-2023 (137).

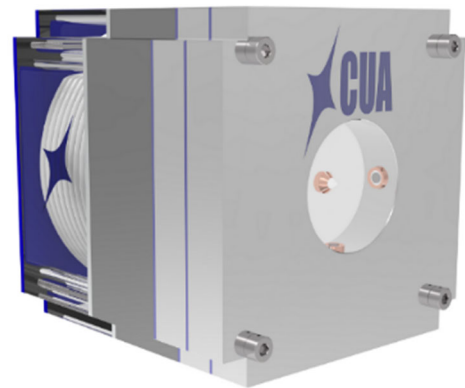


Figure 4.45: FPPT module. Credit: CU Aerospace.

### d. Summary Table of Devices

See table 4-11 for current state-of-the-art pulsed plasma and vacuum arc devices applicable to small spacecraft.

## Ambipolar

### a. Technology Description

Ambipolar thrusters ionize gaseous propellant within a discharge cavity via various means, including DC breakdown or RF excitation. The escape of high-mobility electrons from the

discharge cavity creates a charge imbalance in the plasma discharge, and the subsequent ambipolar diffusion accelerates ions out of the cavity to generate thrust.

Because the thruster plume is charge neutral, no neutralizer assembly is necessary. A variety of propellants are theoretically usable due to the absence of exposed electrodes (and their associated material compatibility concerns).

#### b. Key Integration and Operational Considerations

- **Propellant Agnostic:** While ambipolar thrusters may be operable on a variety of propellants thanks to the devices' lack of exposed electrodes, different propellants will have different ionization costs (i.e., impact on thruster efficiency), plume behavior, and propellant storage requirements that should be considered during propellant selection.
- **Electromagnetic Interactions:** For RF-discharge thrusters, electromagnetic interference and compatibility (EMI/EMC) testing may be critical to assess the impact of thruster operations on spacecraft communications and payload functionality.
- **Thermal Soakback:** Low thruster efficiencies may result in large thermal loads on the spacecraft due to thermal soakback. Validated thermal modeling should be considered to assess impacts to the host spacecraft.

#### c. Missions

The SpaceX Falcon 9 Transporter-1 launch in January 2021 included two SmallSats with the Phase Four Maxwell Block 1 onboard. This integrated propulsion system (figure 4.46) includes the RF thruster and power electronics along with a xenon propellant tank and feed system (232).

The UniSat-7 mission, led by GAUSS, is a 36-kg microsatellite that launched via Soyuz-2-1a Fregat in March 2021. This technology demonstration mission included a T4i iodine-propellant REGULUS module (figure 4.47); the integrated propulsion system includes thruster, power processing unit, and heated propellant-feed components. The propulsion demonstration is expected to include orbit raising and lowering between orbital altitudes of 300 and 400 km (234) (235).

A 6U CubeSat from Team Miles was awarded a rideshare slot onboard Artemis I, as one of the winning teams in NASA's Cube Quest Challenge. The objective of the mission is to demonstrate deep space communications from beyond a 2.5 million mile range. Twelve ConstantQ water-propellant thrusters (figure 4.48), an earlier version



Figure 4.46: Maxwell Block 1. Credit Phase Four.

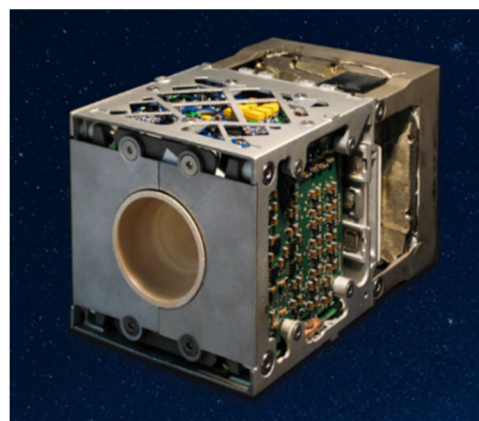


Figure 4.47: REGULUS propulsion module. Credit: T4i.

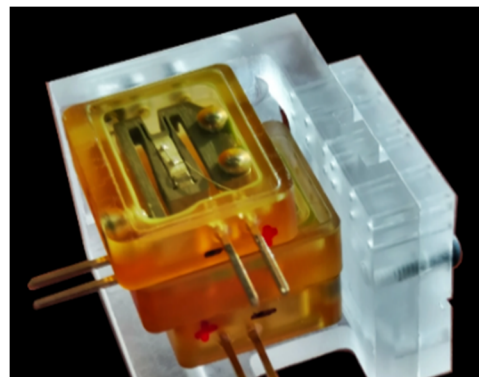


Figure 4.48: ConstantQ thruster head. Credit: Miles Space.



of Team Miles' M1.4 system, are integrated onboard the CubeSat to provide primary propulsion as well as 3-axis control (236) (237).

#### d. Summary Table of Devices

See table 4-12 for current state-of-the-art ambipolar devices applicable to small spacecraft.

### 4.6.3 In-Space Propellant-less Propulsion

Propellant-less propulsion systems generate thrust via interaction with the surrounding environment (e.g., solar pressure, planetary magnetic fields, and planetary atmosphere). By contrast, chemical and electric propulsion systems generate thrust by expulsion of reaction mass (i.e., propellant). Three propellant-less propulsion technologies that have undergone in-space demonstrations to date include solar sails, electrodynamic tethers, and aerodynamic drag devices.

#### Solar Sails

Solar sails use solar radiation pressure to generate thrust by reflecting photons via lightweight, highly-reflective membranes. While no commercial products are presently available, a handful of missions have sought to demonstrate the technology using small spacecraft. Recent missions include:

- NASA's NanoSail-D2 launched as a 3U CubeSat secondary payload onboard the Fast, Affordable, Science and Technology Satellite (FASTSAT) bus in November 2010. The 10 m<sup>2</sup> sail made of CP-1 deployed from a 650 km circular orbit and de-orbited the spacecraft after 240 days in orbit (238).
- The Planetary Society's LightSail 2 mission launched as a 3U CubeSat secondary payload on the Department of Defense's Space Test Program (STP-2) in June 2019. The 32 m<sup>2</sup> mylar solar sail was deployed at 720 km altitude and demonstrated apogee raising of ~10 km. Its mission was still ongoing as of September 2022 (239).
- The University of Illinois (Urbana, IL) and CU Aerospace LLC (Champaign, IL) teamed to develop CubeSail, which launched as one of ten CubeSats on the Educational Launch of Nanosatellites ELaNA-19 mission on a Rocket Lab Electron rocket in December 2018. CubeSail launched as a mated pair of 1.5U CubeSats. When separated, it intended to deploy a 250 m-long, 20 m<sup>2</sup> aluminized mylar film between them. The development team envisions the CubeSail mission as the first of many missions of progressively increasing scale and complexity (240). Satellite beacons at the correct frequency were observed post-launch once on 18 Dec. 2018, but not with sufficient signal to noise ratio to demodulate the call sign in the beacons. No further communications were received from CubeSail. After more than 2 years of continued efforts to establish full communication with CubeSail, it is believed that the satellites irrevocably failed. While it is uncertain the specific cause, the best assessment is that the radios failed in orbit. Due to the lack of communications, CubeSail was never able to attempt sail deployment or attempt to demonstrate sail control and deorbiting (241).
- NASA's Near-Earth Asteroid (NEA) Scout mission launched as a secondary payload onboard Artemis I November 2022. The 6U CubeSat will deploy an 85 m<sup>2</sup> solar sail and conduct a flyby of Asteroid 1991VG, approximately 1 AU from Earth (242).

#### Electrodynamic Tethers

Electrodynamic tethers employ an extended, electrically conductive wire with current flow. In addition to atmospheric drag on the wire, its interaction with the ambient magnetic field about a

planetary body causes a Lorentz force that can be used for orbit raising or lowering. This technology currently provides a means for end-of-mission small spacecraft deorbit.

#### a. Missions

Georgia Institute of Technology's Prox-1 mission was launched as a secondary payload on the Department of Defense's Space Test Program (STP-2) in June 2019. The 70 kg spacecraft served as the host and deployer for the LightSail 2 mission. The Prox-1 spacecraft housed a Tethers Unlimited Nanosat Terminator Tape (NSTT), shown in figure 4.49, which deployed a 70 m tether in September 2019 to lower the orbit from 717 km. Data from the Space Surveillance Network indicate that the NSTT is causing Prox-1 to deorbit more than 24 times faster than otherwise expected. This rate of orbital decay will enable Prox-1 to meet its 25-year deorbit requirement (243) (244) (245). The Naval Postgraduate School's NPSat-1 was launched as a secondary payload on STP-2 and deployed its NSTT in late 2020 (245). TriSept's DragRacer technology demonstration mission, launched as a rideshare onboard an Electron rocket in November 2020, sought to conduct a direct comparison of the deorbiting rates of two Millennium Space Systems satellites, one of which will use a 250 m NSTT (245) (246). A comparison of flight data for operation of the NSTT from each of these three missions has been publicly released (247).



Figure 4.49: Nanosat Terminator Tape (NSTT). Credit: Tethers Unlimited.

The AuroraSat-1 satellite was launched on an Electron rocket on May 5, 2022. (140) (141) The spacecraft is built by SatRevolution with Aurora Propulsion Technologies providing the payloads. The mission serves as a technology demonstration for a Plasma Brake module (139) (figure 4.50), and an Aurora Resistojet Module for Attitude control (ARM-A) (138) (figure 4.21), both produced by Aurora. The Plasma Brake module on AuroraSat-1 is a dual redundant system for demonstration purposes. A 50-m tether will be deployed to demonstrate its deorbiting capability.

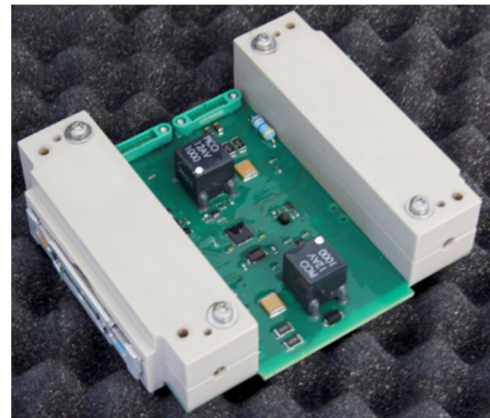


Figure 4.50: Plasma Brake Module (PBM) demo unit. Credit: Aurora Propulsion Technologies.

#### Aerodynamic Drag

Satellites have historically deorbited from low-Earth orbits with the aid of thrusters or passive atmospheric drag. Given the increasing rate of new spacecraft launched, and in-turn potential for new orbital debris following completion of missions, orbital debris management has gained increasing attention. Space debris poses a growing threat to active satellites and human activity in space. Allowing decades for defunct spacecraft to decay naturally from low-Earth orbit may soon be insufficient, and aerodynamic drag devices may provide one method to rapidly remove spacecraft from low-Earth orbits upon mission completion.

Below about 1,000 km altitude, the atmosphere exerts a measurable drag force opposite the relative motion of any spacecraft, which results in a slow orbital decay. The intensity of the drag force exerted on the spacecraft depends on numerous factors such as local atmospheric density, the spacecraft forward facing area, the spacecraft velocity, and a drag coefficient. The drag coefficient accounts for the drag force's dependency on an object's unique geometric profile.



While the spacecraft velocity and local atmospheric density are largely mission dependent, a spacecraft's forward-facing area and drag coefficient can be altered by introducing aerodynamic drag devices such as exo-brakes and ballutes. These deployable or inflatable parachutes and balloons can greatly increase the drag force exerted on spacecraft by an order of magnitude or more and significantly increase the rate of orbital decay.

Furthermore, aerodynamic drag devices may be useful to reduce spacecraft propellant mass required for orbit capture and disposal at other planetary bodies, given sufficient atmospheric density exists.

For further details on these devices, see chapter on Deorbit Systems.



Table 4-2: Hydrazine Chemical Propulsion

Manufacturer	Product	Propellant	Thrust per Thruster (Quantity)	Specific Impulse	Total Impulse	Mass	Envelope	Power	ACS	PMI Status	Missions	References
---	---	---	[N]	[s]	[kN-s]	[kg]	[cm <sup>3</sup> or U]	[W]	Y/N	C,D,E,F	---	---
<b>Integrated Propulsion Systems</b>												
Aerojet Rocketdyne	MPS-120	Hydrazine	0.25 – 1.0 (4)	N/A	>2 (2U) >0.8 (1U)	1.6 – 2.5 † 1.2 – 1.5 ‡	1U – 2U	N/A	Y	D	-	(76)
Aerojet Rocketdyne	MPS-125	Hydrazine	0.25 – 1.0 (4)	N/A	>19 (8U) >13 (6U) >7 (4U)	6.2 – 12.1 † 3.6 – 5.1 ‡	4U – 8U	N/A	Y	D	-	(76)
Stellar Exploration	Monopropellant CubeSat System	Hydrazine	-	200s	-	-	-	-	Y	F	Echostar Global 3 (2021), NASA Capstone (2022)	(77) (78) (79)
Stellar Exploration	Bipropellant CubeSat system	Hydrazine/ NTO	-	285	-	-	-	-	Y	D	-	(79)
<b>Thruster</b>												
Aerojet Rocketdyne	MR-103	Hydrazine	1	202-224	183	0.33-0.37	-	16 max total	-	F	numerous	(8)
Aerojet Rocketdyne	MR-111	Hydrazine	4	219-229	262	0.37	-	16 max total	-	F	numerous	(8)
Aerojet Rocketdyne	MR-106	Hydrazine	22	228-235	561	0.59	-	36 max total	-	F	numerous	(8)
ArianeGroup	1 N	Hydrazine	1	200 – 223	135	0.29	-	N/A	-	F	numerous	(6)
Moog	MONARC-1	Hydrazine	1	227	111	0.38	113x50 mm	18 (Valve)	-	F	numerous	(9)
Moog	MONARC-5	Hydrazine	4.5	226	613	0.49	203x380 mm	18 (Valve)	-	F	numerous	(9)
Moog	MONARC-22-6	Hydrazine	22	228	533	0.72	203x380 mm	30 (Valve)	-	F	numerous	(9)
Moog	MONARC-22-12	Hydrazine	22	228	1,173	0.69	229x530 mm	30 (Valve)	-	F	numerous	(9)
Moog	DST-11H	N2H4/MON	22	310	907 kg	0.77	261 mm long	41 (Valve)	-	F	numerous	(9)
Moog	DST-12	MMH/MON	22	302	1073 kg	0.64	244 mm long	9 (Valve)	-	F	numerous	(9)
Moog	DST-13	MMH/MON	22	298	637 kg	0.68	264 mm long	41 (Valve)	-	F	NASA SDO	(9)
Moog	5 lbf	MMH/MON	22	290	484 kg	0.64-0.91	248-343 mm	15.6 (Valve)	-	F	Numerous	(9)
Northrop Grumman	MRE-0.1	Hydrazine	1	216	34 kg	0.5	114x175 mm	15	-	F	numerous	(10)
Northrop Grumman	MRE-1.0	Hydrazine	5	218	544 kg	0.5	114x188 mm	15	-	F	numerous	(10)
Northrop Grumman	MRE-4.0	Hydrazine	18	217	249 kg	0.5	61x206 mm	30	-	F	numerous	(10)

Note that all data is documented as provided in the references. Unless otherwise published, do not assume the data has been independently verified.

† denotes a wet mass, ‡ denotes a dry mass, N/A = Not Available



Table 4-3: Alternative Monopropellant and Bipropellant Propulsion

Manufacturer	Product	Propellant	Thrust per Thruster (Quantity)	Specific Impulse	Total Impulse	Mass	Envelope	Power	ACS	PMI Status	Missions	References
---	---	---	[N]	[s]	[kN-s]	[kg]	[cm <sup>3</sup> or U]	[W]	Y/N	C,D,E,F	---	---
<b>Integrated Propulsion Systems</b>												
Aerojet Rocketdyne	MPS-130	AF-M315E	0.25 – 1.0 (4)	N/A	>2.7 (2U) >1.1 (1U)	1.7 – 2.8 † 1.1 – 1.4 ‡	1U – 2U	N/A	Y	D	-	(75) (76)
Aerojet Rocketdyne	MPS-135	AF-M315E	0.25 – 1.0 (4)	N/A	>19 (8U) >13.7 (6U) >7.3 (4U)	7.2 – 14.7 † 3.5 – 5.1 ‡	4U – 8U	N/A	Y	D	-	(76)
Aerospace Corp.	HyPer	Hydrogen Peroxide	N/A	N/A	N/A	N/A	~0.25U	N/A	N/A	D	-	(80)
Benchmark Space Systems	Halcyon	HTP & Alcohol	100 mN-22 N	270	1.7-10	2.5-7.5†	2000 – 7800 cm <sup>3</sup>	up to 10 W	Y	F	Tenzing-01 (2021)	(29) (81) (82)
Bradford-ECAPS	Skysat 1N HPGP Propulsion System	LMP-103S	1.0 (4)	>200	21	22†	55x55x15 cm	10	Y	F	Skysat, PRISMA, Astroscale	(16) (17) (18) (19) (89) (90)
Busek	BGT-X5 System	AF-M315E	0.5	220 – 225	N/A	1.5 (BOL)	1U	20	N	D	-	(91)
Cornell Univ.	Cislunar Explorer	Water (Electrolysis)	N/A	N/A	N/A	N/A	6U total (2-units)	N/A	N/A	E	CubeQuest Challenge (Artemis I)	(24)
CU Aerospace	MPUC	(CMP-8X) Peroxide/Ethanol blend	0.16 (1)	160 – 180	1.6 - 2.5	2.5 – 3.1 † 1.6 – 1.9 ‡	1.5U – 2U	6	N	D	-	(85) (93) (94)
Dawn Aerospace / AAC Hyperion	PM200	Nitrous Oxide & Propene	0.5 (1)	>285	>0.4 – 0.8	1.0 – 1.4	0.7 – 1U	12	Y	D	-	(31)
Moog	Monopropellant Propulsion Module	Green or 'Traditional'	0.5 (1)	224	0.5	1.01†	1U (baseline)	2 x 22.5 W/Thruster	N	D	-	(87)
MSFC	LFPS	AF-M315E	0.1 (4)	>200s	>3.5	<5.5kg	~2.4U	15 – 47W*	Y	E	Lunar Flashlight (Artemis I)	(20)
NanoAvionics	EPSS C1K	IADN-blend	1.0 (1) BOL 0.22 (1) EOL	213	>0.4	1.2 † 1.0 ‡	1.3U	0.19 (monitor) 9.6 (preheat) 1.7 (firing)	N	F	Lituanica-2	(30)
Rocket Lab	Kick Stage	Unknown	120	N/A	N/A	N/A	N/A	N/A	Y	F	Electron Kick Stage	(32) (33)
Tethers Unlimited	HYDROS-C	Water (Electrolysis)	1.1 (1)	>310	>2	2.61 † 1.87 ‡	190 mm x 130 mm x 92 mm	5-25	N	F	Pathfinder Technology Demonstration	(27) (28) (86) (95)
Tethers Unlimited	HYDROS-M	Water (Electrolysis)	>1.2 (1)	>310	>18	12.6 † 6.4 ‡	381 mm dia. x 191 mm	7-40	N	D	-	(86)
VACCO	ArgoMoon Hybrid MiPS	LMP-103S/cold-gas	0.1 (1)	190	1	14.7 † 9 ‡	~1.3U	13.6 20 (max)	Y	E	ArgoMoon (Artemis I)	(60) (98)
VACCO	Green Propulsion System (MiPS)	LMP-103S	0.1 (4)	190	4.5	5 † 3 ‡	~3U	15 (max)	Y	D	-	(60) (96)
VACCO	Integrated Propulsion System	LMP-103S	1.0 (4)	200	12.5	14.7 † 9 ‡	~1U – 19,000 cm <sup>3</sup>	15 – 50 (max)	Y	E	-	(60) (97)

Note that all data is documented as provided in the references. Unless otherwise published, do not assume the data has been independently verified.

† denotes a wet mass, ‡ denotes a dry mass, N/A = Not Available





Table 4-3 (cont.): Other Monopropellant and Bipropellant Propulsion

Manufacturer	Product	Propellant	Thrust per Thruster (Quantity)	Specific Impulse	Total Impulse	Mass	Envelope	Power	ACS	PMI Status	Missions	References
---	---	---	[N]	[s]	[kN-s]	[kg]	[cm <sup>3</sup> or U]	[W]	Y/N	C,D,E,F	---	---
<b>Integrated Propulsion Systems (cont.)</b>												
VACCO	Green Propulsion System (MiPS)	LMP-103S	0.1 (4)	190	4.5	5 † 3 ‡	~3U	15 (max)	Y	D	-	(60) (96)
VACCO	Integrated Propulsion System	LMP-103S	1.0 (4)	200	12	14.7 † 9 ‡	~1U	15 – 50 (max)	Y	D	-	(60) (97)
<b>Thruster Heads</b>												
Aerojet Rocketdyne	GR-M1	AF-M315E	0.25	195	3.45	--	--	7	-	D	-	(34)
Aerojet Rocketdyne	GR-1	AF-M315E	0.4-1.1	231	23	N/A	-	12	-	F	GPIM	(8) (14)
Aerojet Rocketdyne	GR-22	AF-M315E	8.0-25	248	74	N/A	-	28	-	E	GPIM	(8) (14)
Aerospace Corp.	Hydrogen Peroxide Vapor Thruster (HyPer)	Hydrogen Peroxide	<10 mN	N/A	N/A	N/A	-	N/A	-	D	-	(80)
Bradford-ECAPS	0.1 N HPGP	LMP-103S	0.03 – 0.10	196 – 209	N/A	0.04 excl. FCV	-	6.3 – 8	-	E	ArgoMoon	(83)
Bradford-ECAPS	1 N HPGP	LMP-103S	0.25 – 1.0	204 – 235	N/A	0.38	-	8 – 10	-	F	PRISMA, SkySat, Astroscale, Tetra-2/3/4, Altair, SL-OMV	(16) (17) (18) (19) (83)
Bradford-ECAPS	1 N GP	LMP-103S/LT	0.25 – 1.0	194 – 227	N/A	0.38	-	8 – 10	-	D	-	(84)
Bradford-ECAPS	5 N HPGP	LMP-103S	1.5 – 5.5	239 – 253	N/A	0.48	-	15 – 25	-	D	-	(83)
Bradford-ECAPS	22 N HPGP	LMP-103S	5.5 – 22	243 – 255	N/A	1.1	-	25 – 50	-	D	-	(83)
Busek	BGT-X1	AF-M315E	0.02 – 0.18	214	N/A	N/A	-	4.5	-	D	-	(92)
Busek	BGT-X5	AF-M315E	0.50	220 – 225	0.5	1.5 †	1U	20	-	D	-	(91) (92)
Busek	BGT-5	AF-M315E	1.0 – 6.0	> 230	N/A	N/A	-	50	-	D	-	(92)
Dawn Aerospace	20N Thruster	N20/Propene	7.3 – 19.8N	>285		0.4	-	12W	-	F	numerous	(36)
NanoAvionics	EPSS	IADN-blend	0.22 – 1.0	213	>0.4	N/A	-	9.6 (preheat) 1.7 (firing)	-	F	Lituanica-2	(30)
Plasma Processes	100mN Thruster PP3490-B	AF-M315E	0.1 – 0.1	195 - 208	N/A	.08	-	7.5 – 10	-	E	Lunar Flashlight	(20)
Rocket Lab	Curie Engine	unk.	120	N/A	N/A	N/A	-	N/A	-	F	Electron 'Still Testing'	(32) (33)

Note that all data is documented as provided in the references. Unless otherwise published, do not assume the data has been independently verified.

† denotes a wet mass, ‡ denotes a dry mass, N/A = Not Available

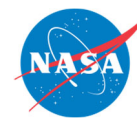


Table 4-4: Hybrid Chemical Propulsion

Manufacturer	Product	Propellant	Thrust (Quantity)	Specific Impulse	Total Impulse	Mass	Envelope	Power	ACS	PMI Status	Missions	References
---	---	---	[N]	[s]	[N-s]	[kg]	[cm <sup>3</sup> or U]	[W]	Y/N	C,D,E,F	---	---
Aerospace Co.	Propulsion Unit for CubeSats	Paraffin/Nitrous Oxide	N/A	N/A	N/A	N/A	1U	N/A	-	D		(44)
JPL	Hybrid Rocket	PMMA/GOX	N/A	>300	N/A	N/A	N/A	N/A	-	D	-	(41) (100) (101) (102)
NASA Ames	Hybrid Rocket	PMMA/ Nitrous Oxide	25	247	N/A	N/A	N/A	N/A	-	D		(42)(43) (101)
Parabilis	ROMBUS	Various/N <sub>2</sub> O	222	260s	Configurable	N/A	ESPA, ESPA Grande	N/A	Y	D		(45)
Parabilis	NanoSat Orbital Transfer System	HTPB/N <sub>2</sub> O	9.4	245s	N/A	3U OTS	Modular, 3U to 50kg sat	N/A	Y	C		(103)
Utah State Univ.	Green Hybrid Rocket	ABS/Nyrox	25-50	220-300	N/A	N/A	3-25U	<30W for 1-2 sec	Y	D		(39)(40)
Utah State Univ.	Green Hybrid Rocket	ABS/GOX	8	215	N/A	N/A	N/A	N/A	-	D	-	(37) (38) (99)

Note that all data is documented as provided in the references. Unless otherwise published, do not assume the data has been independently verified.  
† denotes a wet mass, ‡ denotes a dry mass, N/A = Not Available



Table 4-5: Cold and Warm Gas Propulsion

Manufacturer	Product	Propellant	Thrust (Quantity)	Specific Impulse	Total Impulse	Mass	Envelope	Power	ACS	PMI Status	Missions	References
---	---	---	[mN]	[s]	[N-s]	[kg]	[cm <sup>3</sup> or U]	[W]	Y/N	C,D,E,F	---	---
<b>Integrated Propulsion Systems</b>												
Aerospace Corp.	MEPSI	R236fa	20	N/A	N/A	0.188	4 in. x 4 in. x 5in.	N/A	Y	E	STS-113 and STS-116	(47)
GomSpace / NanoSpace	Nanoprop CGP3	Butane	0.01 – 1 (x4)	60-110	40	0.3‡ 0.35†	0.5U	<2	Y	D	-	(53) (116)
GomSpace / NanoSpace	Nanoprop 6U	Butane	1 – 10 (x4)	60-110	80	0.770‡ 0.900†	200 mm x 100 mm x 50 mm	<2	Y	F	GomX-4	(53) (54) (117)
Lightsey Space Research	BioSentinel Propulsion System	R236fa	40 - 70	40.7	79.8	1.08 kg ‡ 1.28 kg †	220 mm x 100 mm x 40 mm	<1 W idle <4 W operating	Y	E	BioSentinel	(55) (56)
Marotta	MicroThruster	Nitrogen	0.05 – 2.36 N	70	N/A	N/A	N/A	<1	N/A	F	numerous	(46)
Micro Space	POPSAT-HIP1	Argon	0.083 – 1.1 (x8)	43	N/A	N/A	N/A	N/A	N/A	F	POPSAT-HIP1	(52)
SSTL	Butane Propulsion System	Butane	0.5 N							D	-	(48) (49)
ThrustMe	I2T5	Iodine	0.2		75	0.9†	0.5U	10	N	F	Xiaoxiang 1-08, Robusta-3A (2021**)	(65) (66) (67) (68)
UTIAS/SFL	CNAPS	Sulfur Hexafluoride	12.5 – 40	30	81	N/A	N/A	N/A	N	F	CanX-4/CanX-5	(118) (119)
VACCO	NEA Scout	R236fa	N/A	N/A	500	2.54†	2U	9	Y	E	NEA Scout (2021**)	(63) (64)
VACCO	MiPS Standard Cold Gas	R236fa	25 (x4)	40	98 – 489	553 – 957‡	0.4 – 1.38U	12 W (max)	Y	D	-	(60) (112)
VACCO	MarCO-A and -B MiPS	R236fa	25 (x8)	40	755	3.5	2U	15	Y	F	MarCO-A & -B	(60) (61) (62) (113)
VACCO	C-POD	R134A	25 (x8)	40	186	1.3	0.8U	5	Y	E	CPOD	(60) (114)
<b>Thruster Heads</b>												
Moog	058E143-146	Nitrogen	10-40	60	-	0.04	14x57 mm	10	-	F	CHAMP, GRACE	(115)
Moog	058E142A	Nitrogen	120	57	-	0.016	14x20 mm	35	-	F	Spitzer Space Telescope	(115)
Moog	058E151	Nitrogen	120	65	-	0.07	19x41 mm	10.5	-	F	Spitzer Space Telescope	(115)
Moog	058-118	Nitrogen	3.6 N	57	-	0.023	6.6x25.4mm	30	-	F	SAFER, Pluto Fast Flyby	(115)
Moog	58E163A	Nitrogen, Xenon, Argon	1.3 N	70 N <sub>2</sub> , 21 Xe, 54 Ar	-	0.115	23.8x53.1	10.5	-	F	GEO applications	(115)

Note that all data is documented as provided in the references. Unless otherwise published, do not assume the data has been independently verified.

† denotes a wet mass, ‡ denotes a dry mass, N/A = Not Available, \*\* anticipated launch date



Table 4-6: Solid Motor Chemical Propulsion												
Manufacturer	Product	Propellant	Thrust (Quantity)	Specific Impulse	Total Impulse	Mass	Envelope	Power	ACS	PMI Status	Missions	References
---	---	---	[N]	[s]	[N-s]	[kg]	[cm <sup>3</sup> or U]	[W]	Y/N	C,D,E,F	---	---
Integrated Propulsion Systems												
D-Orbit	D-Raise	N/A	N/A	N/A	N/A	50 – 78	N/A	N/A	N	D	-	(110)
D-Orbit	D3	N/A	N/A	N/A	N/A	16 – 257	32 cm x 32 cm x 25 cm to 1100 cm x 500 cm x 1000 cm	N/A	N	D	-	(111)
DSSP	CAPS-3	HIPEP-501A	0.3 (3)	N/A	0.125	0.023	0.92 cm x 2.79 cm x 4.2 cm	< 2.3	N	F	SPINSAT	(70) (104)
DSSP	MPM-7	HIPEP-H15	N/A	200	1.5	<750 g (PPU)	< 0.75 U	200	N	D	-	(105)
PacSci EMC	MAPS	N/A	N/A (176 per lightband)	210	N/A	N/A	38 cm x 10.5 cm	N/A	N/A	F	PACSCISAT	(71) (72)
PacSci EMC	P-MAPS	N/A	N/A	N/A	N/A	N/A	N/A	N/A	N/A	D	-	(71)
Thruster Heads												
DSSP	CDM-1	AP/HTPB	186.8	235	226.4	0.046	0.64 dia x 0.47 length	< 5	-	D	Listed as "flight qualified"	(106) (107)
Industrial Solid Propulsion	ISP 30 sec. Motor	80% Solids HTPB/AP	37	187	996	0.95	5.7 cm	-	-	D	Optical target at Kirtland AFB	(69) (108)
Northrop Grumman (Former Orbital ATK)	STAR 4G	TP-H-3399	258	276	595	1.49	11.3 cm dia. x 13.8	-	-	D	-	(69) (109)

Note that all data is documented as provided in the references. Unless otherwise published, do not assume the data has been independently verified.

† denotes a wet mass, ‡ denotes a dry mass, N/A = Not Available



Table 4-7: Electrothermal Electric Propulsion												
Manufacturer	Product	Propellant	Thrust*	Specific Impulse*	Total Impulse*	Mass	Envelope	Power	ACS	PMI Status	Missions	References
---	---	---	[mN]	[s]	[N-s]	[g]	[cm <sup>3</sup> or U]	[W]	Y/N	C,D,E,F	---	---
Integrated Propulsion Systems												
Aurora Propulsion Technologies <sup>Finland</sup>	ARM-A	H <sub>2</sub> O	0.5	100	70	280 <sup>†</sup>	0.3U	10 <sup>£</sup>	Y	E	AuroraSat-1 (2022)	(138) (140) (141)
Aurora Propulsion Technologies <sup>Finland</sup>	ARM-C	H <sub>2</sub> O	1	-	-	50 <sup>†</sup>	45	12 (max)	N	D	---	(142)
Busek <sup>USA</sup>	Micro Resistojet	Ammonia	10	150	404	1,250 <sup>†</sup>	1U	15	Y	D	---	(248)
Bradford Space <sup>Netherlands</sup>	Comet-1000	H <sub>2</sub> O	17	>175	1,155	1,440 <sup>†</sup>	2,600	55 (max)	N	F	HawkEye 360, Capella Space	(122) (123) (124)
Bradford Space <sup>Netherlands</sup>	Comet-8000	H <sub>2</sub> O	17	>175	8,348	6,675 <sup>†</sup>	23,760	55 (max)	N	F	BlackSky Global	(122) (125)
CU Aerospace <sup>USA</sup>	CHIPS-180	R236fa	16	56	176	1,079 <sup>†</sup>	540	20	Y	D	---	(249) (250) (251) (252)
CU Aerospace <sup>USA</sup>	CHIPS-500	R236fa	25	58	505	1,985 <sup>†</sup>	1300	25	Y	D	---	(249) (250) (251) (252)
CU Aerospace <sup>USA</sup>	CHIPS-1000	R236fa	25	58	1,000	3,425 <sup>†</sup>	2500	25	Y	D	---	(249) (250) (251) (252)
CU Aerospace and VACCO <sup>USA</sup>	PUC	SO <sub>2</sub>	4.5	70	184	718 <sup>†</sup>	0.35U	15	N	E	8 flight units delivered to AFRL	(126) (127) (128)
CU Aerospace <sup>USA</sup>	MVP	Delrin Fiber	4.5	66	280	1,055 <sup>†</sup>	0.93U	39	N	E	DUPLEX (launch 2023 <sup>**</sup> )	(129) (130) (131)
Thruster Heads												
Sitael <sup>Italy</sup>	XR-150	Xe	65	57	NA	220 <sup>‡</sup>	21.6	100	NA	D	---	(253) (254)
Sitael <sup>Italy</sup>	XR-150	Kr	67.2	70	NA	220 <sup>‡</sup>	21.6	100	NA	D	---	(253) (254)

Note that all data is documented as provided in the references. Unless otherwise published, do not assume the data has been independently verified.

\*nominal values (see references for full performance ranges), \*\* anticipated launch date, † denotes a wet mass, ‡ denotes a dry mass, £ per active thruster, NA = Not Applicable



Table 4-8: Electro Spray Electric Propulsion

Manufacturer	Product	Propellant	Thrust*	Specific Impulse*	Total Impulse*	Mass	Envelope	Power	Neutralizer	PMI Status	Missions	References
---	---	---	[ $\mu$ N]	[s]	[N-s]	[kg]	[cm <sup>3</sup> or U]	[W]	---	C,D,E,F	---	---
<b>Integrated Propulsion Systems</b>												
Accion Systems <sup>USA</sup>	TILE-2	EMI-BF4 (ionic)	50	1,650	35	0.45 <sup>†</sup>	0.5U	4	NA	E	Astro Digital Tenzing, BeaverCube	(158) (270)
Accion Systems <sup>USA</sup>	TILE-3	EMI-BF4 (ionic)	450	1,650	755	2.25 <sup>†</sup>	1U	20	NA	E	D2/AtlaCom-1	(159) (160) (161) (271)
Busek <sup>USA</sup>	CMNT (4x heads)	EMI-Im (ionic)	4 x 20	225	980	14.8 <sup>†</sup>	29U	16.5	Carbon Nanotube	F	LISA Pathfinder	(143)
Busek <sup>USA</sup>	BET-MAX (Config. A)	EMI-Im (ionic)	4 x 55	850	92 <sup>§</sup>	0.8 <sup>†</sup>	1250	12	Carbon Nanotube	E	US Government	(255) (256) (257) (258) (259) (260) (261)
Busek <sup>USA</sup>	BET-MAX (Config. B)	EMI-Im (ionic)	4 x 55	2300	250	0.8 <sup>†</sup>	1250	14	Carbon Nanotube	D	---	(255) (256) (257) (258) (259) (260) (261)
Enpulsion <sup>Austria</sup>	IFM Nano	Indium (FEFP)	330	3,500	>5,000	0.90 <sup>†</sup>	10 x 10 x 8.3	40	Thermionic	F	Flock 3p', ICEYE X2, Harbinger, NetSat	(144) (145) (146) (147) (148) (149) (150) (151) (262) (263) (264)
Enpulsion <sup>Austria</sup>	IFM Nano R <sup>3</sup>	Indium (FEFP)	350	3,500	>5,000	1.4 <sup>†</sup>	9.8 x 9.9 x 9.5	45	Thermionic	E	(Evolution of Nano design)	(151) (152) (265)
Enpulsion <sup>Austria</sup>	IFM Micro R <sup>3</sup>	Indium (FEFP)	1,000	3,000	---	3.9 <sup>†</sup>	14 x 12 x 13.3	100	Thermionic	F	GMS-T	(152) (153) (266) (267)
Morpheus Space <sup>Germany</sup>	NanoFEFP (2x heads)	Gallium (FEFP)	<40	---	---	0.16 <sup>†</sup>	9 x 2.5 x 4.3	<3	Propellant-less	E	UWE-4	(154) (155) (268) (269)
Morpheus Space <sup>Germany</sup>	MultiFEFP (2x heads)	Gallium (FEFP)	<140	---	---	0.28 <sup>†</sup>	9 x 4.5 x 4.5	<19	Propellant-less	D	---	(268)

Note that all data is documented as provided in the references. Unless otherwise published, do not assume the data has been independently verified.

\*nominal values (see references for full performance ranges), \*\* anticipated launch date, † denotes a wet mass, ‡ denotes a dry mass, § demonstrated, NA = Not Applicable



Table 4-9: Gridded-Ion Electric Propulsion												
Manufacturer	Product	Propellant	Thrust*	Specific Impulse*	Total Impulse*	Mass	Envelope	Power	Cathode Type	PMI Status	Missions	References
---	---	---	[mN]	[s]	[kN-s]	[kg]	[cm <sup>3</sup> or U]	[W]	---	C,D,E,F	---	---
<b>Integrated Propulsion Systems</b>												
Avant Space <sup>Russia</sup>	GT-50 <sup>RF</sup>	Xenon	<7	---	---	<8 <sup>†</sup>	<4U	<240	Hollow	D	---	(272) (273)
Busek <sup>USA</sup>	BIT-3 <sup>RF</sup>	Iodine	1.15	2,100	32	2.9 <sup>†</sup> (with gimbal)	18 x 8.8 x 10.2	75	RF	E	Lunar IceCube (2022**); LunaH-Map (2022**)	(168) (169) (170) (274) (275) (276) (277) (278)
Pale Blue <sup>Japan</sup>	PBI-40 <sup>RF</sup>	Water	0.17	500	>1	1.8 <sup>†</sup>	>1.5U	40	RF	E	JAXA RAISE-3 (DDL)	(279) (280) (281)
ThrustMe <sup>France</sup>	NPT30 <sup>RF</sup>	Xenon	<1.1	---	---	<1.7 <sup>†</sup>	<2U	<60	Thermionic	D	---	(282)
ThrustMe <sup>France</sup>	NPT30-I2 <sup>RF</sup>	Iodine	<1.1	---	---	1.2 <sup>†</sup> (1U) or 1.7 <sup>†</sup> (1.5U)	1U or 1.5U	<65	Thermionic	F	Beihangkongshi-1; NORSAT-TD (2022**); GOMX-5 (2022**)	(165) (166) (167) (283) (284) (285)
<b>Thruster Heads</b>												
Ariane Group <sup>Germany</sup>	RIT $\mu$ X <sup>RF</sup>	Xenon	<0.5	---	---	0.44 <sup>‡</sup>	7.8 x 7.8 x 7.6	<50	RF	D	---	(286) (287) (288) (289) (290) (291)
Ariane Group <sup>Germany</sup>	RIT 10 EVO <sup>RF</sup>	Xenon	<15	---	---	1.8 <sup>‡</sup>	18.6 x 18.6 x 13.4	<435	Hollow	E	(Identical to flight-heritage RIT-10 with contemporary grid design)	(286) (288) (292)
QinetiQ <sup>UK</sup>	T5 <sup>DC</sup>	Xenon	<20	<3,000	---	2 <sup>‡</sup>	19 x 19 x 24.2	<600	Hollow	F	GOCE	(163) (164) (293) (294)

Note that all data is documented as provided in the references. Unless otherwise published, do not assume the data has been independently verified.  
 \*nominal values (see references for full performance ranges), \*\* anticipated launch date, † denotes a wet mass, ‡ denotes a dry mass, NA = Not Applicable, RF = Radio Frequency, DDL = Destroyed During Launch

Table 4-10: Hall-Effect Electric Propulsion Thrusters												
Manufacturer	Product	Propellant	Thrust*	Specific Impulse*	Total Impulse*	Mass	Envelope	Thruster Power*	Cathode Type	PMI Status	Missions	References
---	---	---	[mN]	[s]	[kN-s]	[kg]	[cm <sup>3</sup> ]	[W]	Notes	C,D,E,F	---	---
Astra <sup>USA</sup>	ASE	Xenon	25	1,400	300	1.0	---	400 <sup>‡</sup>	CM-HL	F	Sherpa-LTE	(196) (197) (198)
Astra <sup>USA</sup>	ASE	Krypton	18	1,300	300	1.0	---	400 <sup>‡</sup>	CM-HL	D	---	(196)
Busek <sup>USA</sup>	BHT-100	Xenon	6.3	1,086	150	1.2	275 wo cath.	105	EM-SH	D	---	(180) (295)
Busek <sup>USA</sup>	BHT-200	Xenon	13	1,390	84 <sup>§</sup>	1.2	675 wo cath.	250 <sup>‡</sup>	EM-SH	F	TacSat-2, FalconSat-5, -6	(180) (181) (296) (297)
Busek <sup>USA</sup>	BHT-200-I	Iodine	14	1390	---	1.2	675 wo cath.	250	EM-SH	E	NASA iSat (Cancelled)	(181) (184) (296)
Busek <sup>USA</sup>	BHT-350	Xenon	17	1,244	212 <sup>§</sup>	1.9	---	350	EM-SH	E	OneWeb Satellites	(182) (183)
Busek <sup>USA</sup>	BHT-600	Xenon	39	1,500	1000 <sup>§</sup>	3.3	1,470 wo cath.	680 <sup>‡</sup>	EM-SH	E	US Government (2021**)	(180) (228) (298) (299)
Busek <sup>USA</sup>	BHT-600-I	Iodine	39	---	---	3.3	1,470 wo cath.	600	EM-SH	D	---	(181) (298) (299) (300)
EDB FakeI <sup>Russia</sup>	SPT-50	Xenon	14	860	126 <sup>§</sup>	1.2	1,092	220	EM-SH	F	Canopus-V	(175) (176) (177) (178) (301)
EDB FakeI <sup>Russia</sup>	SPT-50M	Xenon	14.8	930	266	1.3	---	220	EM-SH	D	---	(301)
EDB FakeI <sup>Russia</sup>	SPT-70BR	Xenon	39	1,470	435 <sup>§</sup>	2.0	1,453	660	EM-SH	F	KazSat-1, KazSat-2	(178) (179)



EDB Fake <sup>Russia</sup>	SPT-70M	Xenon	41.3	1,580	---	---	---	660	EM-SH	D	---	(179)
EDB Fake <sup>Russia</sup>	SPT-70M	Krypton	31.3	1,460	---	---	---	660	EM-SH	D	---	(179)
ExoTerra <sup>USA</sup>	Halo	Xenon	20.5	1,190	440	0.79	330	310	CM-HL	E	Tipping Point (2024**), Blackjack (2022**)	(211) (212) (213) (214) (215) (216)
ExoTerra <sup>USA</sup>	Halo 12	Xenon	55	1920	>5,000	3.4	1,700	1,000	CM-HL	D <sup>1</sup>	---	(217) (218)
Exotrail <sup>France</sup>	ExoMG nano	Xenon	2.5	800	6	---	---	60	EM-SH	F	M6P Demo (2020), Arthur (2021) ELO3 and ELO4 (2022**)	(201) (202) (203) (204) (205) (206) (207)
Exotrail <sup>France</sup>	ExoMG micro	Xenon	7	1,000	60	---	960	150	EM-SH	E	York cislunar mission (2022**), SpaceVan (2023**)	(201) (204) (208) (209) (210)
Exotrail <sup>France</sup>	ExoMG mini	Xenon	23	1,300	300	--	---	400	EM-SH	D	---	(201)
JPL <sup>USA</sup>	MaSMi	Xenon	55	1,920	>5,000	3.4	1,700	1,000	CM-HL	D	---	(302) (303) (304) (305) (306) (307) (308) (309) (310) (311)(312)(313)
Northrop Grumman <sup>USA</sup>	NGHT-1X	Xenon	55	1,700	2,100	3.1	---	900	CM-SH	E	MEP (2024**)	(219) (220) (221) (222)
Orbion <sup>USA</sup>	Aurora	Xenon	12	1,220	200	1.5	1,147	200	EM-SH	E	AST SpaceMobile (2022**), DARPA Blackjack (**), GA-EMS (**)	(223) (224) (225) (226) (227) (314)
Rafael <sup>Israel</sup>	R-200	Xenon	13	1,160	200	---	---	250	EM-HL	D	---	(185) (186) (187)
Rafael <sup>Israel</sup>	IHET-300	Xenon	>14.3	>1,210	>135	1.5	1,836	300	EM-SH	F	VENuS	(185) (188) (189) (190)
Rafael <sup>Israel</sup>	R-800	Xenon	---	---	600	---	---	800	EM-HL	D	---	(185) (192)
Safran <sup>France</sup>	PPS-X00	Xenon	43	1,530	1,000	< 3.2	---	650	EM-SH	D	---	(315) (316)
SITAEL <sup>Italy</sup>	HT100	Xenon	9	1,300	73	---	407 wo cath.	175	EM-SH	E	uHETSat (2022**)	(193) (194) (195)
SITAEL <sup>Italy</sup>	HT400	Xenon	27.5	1230	1,000	2.77	1,330	615	EM-SH	D	---	(317) (318) (319)
SETS <sup>Ukraine</sup>	ST25	Xenon	7.6	1,000	82	0.75	1,003	140	EM-SH	D	---	(320) (321)
SETS <sup>Ukraine</sup>	ST40	Xenon	25	1,450	450	1.1	1,170	450	EM-HL	D	---	(322)

Note that all data is documented as provided in the references. Unless otherwise published, do not assume the data has been independently verified.  
 \*nominal values (see references for full performance ranges), \*\* anticipated launch date, ‡ PPU input power, § demonstrated, CM = Center Mounted, EM = Externally Mounted, SH = Swaged Heater, HL = Heater-less, JPL = Jet Propulsion Laboratory, SETS = Space Electric Thruster Systems, EDB = Experimental Design Bureau, <sup>1</sup>ExoTerra is commercializing the JPL developed MaSMi thruster





Table 4-11: Pulsed Plasma and Vacuum Arc Electric Propulsion													
Manufacturer	Product	Propellant	Thrust*	Impulse Bit	Specific Impulse*	Total Impulse*	Mass	Envelope	Power*	ACS	PMI Status	Missions	References
---	---	---	[ $\mu$ N]	[ $\mu$ Ns]	[s]	[N-s]	[kg]	[cm <sup>3</sup> or U]	[W]	Y/N	C,D,E,F	---	---
<b>Integrated Propulsion Systems</b>													
Applied Sciences Corp. <sup>USA</sup>	Metal Plasma Thruster	Molybdenum	600	150	1,756	4,000	0.85	0.7U	50	N	D	---	(323)
Busek <sup>USA</sup>	BmP-220	PTFE	20	20	---	175	0.5	375 + ESV	3	N	D	---	(324)
Comat <sup>France</sup>	Plasma Jet Pack	(metal)	288	29	---	4,000	1.0	1U	30	N	D	---	(325) (326)
CU Aerospace <sup>USA</sup>	FPPT-1.7	PTFE Fiber	170	165	3,200	24,000	3.0 <sup>†</sup>	1.7U	32	N	E	DUPLEX (2023 <sup>**</sup> )	(132) (133) (134) (135)
Mars Space Ltd <sup>UK</sup> Clyde Space <sup>Sweden</sup>	PPTCUP	PTFE	40	40	655	48	0.27	0.33U	2.7	N	D	---	(327)

Note that all data is documented as provided in the references. Unless otherwise published, do not assume the data has been independently verified.  
\*nominal values (see references for full performance ranges), \*\* anticipated launch date, † denotes a wet mass, ‡ denotes a dry mass, NA = Not Applicable, ESV = Ejector Spring Volume

Table 4-12: Ambipolar Electric Propulsion													
Manufacturer	Product	Propellant	Thrust*	Specific Impulse*	Total Impulse*	Mass	Envelope	Power	ACS	PMI Status	Missions	References	
---	---	---	[mN]	[s]	[kN-s]	[kg]	[cm <sup>3</sup> ]	[W]	Y/N	C,D,E,F	---	---	
<b>Integrated Propulsion Systems</b>													
Phase Four <sup>USA</sup>	Maxwell (Block 1) <sup>RF</sup>	Xenon	7	400	5	5.9 <sup>‡</sup>	19 x 13.5 x 19	450	N	F	Capella	(232) (233) (328) (329) (330) (331)	
Phase Four <sup>USA</sup>	Maxwell (Block 2) <sup>RF</sup>	Xenon	13	700	---	5.0 (without tank)	22 x 12 x 24 (without tank)	450	N	D	(Deliveries Claimed, but Customer/Mission Not Reported)	(331) (332)	
T4i <sup>Italy</sup>	REGULUS <sup>RF</sup>	Iodine	0.55	550	3	2.5 <sup>†</sup>	1.5U	50	N	E	UniSat-7	(234) (235) (333)	
Miles Space <sup>USA</sup>	M1.4	Water	2.8	1340	3.3	0.8 <sup>†</sup>	9 x 9 x 9.5	<11.5	N	E	Team Miles (2021 <sup>**</sup> )	(236) (237) (334)	

Note that all data is documented as provided in the references. Unless otherwise published, do not assume the data has been independently verified.  
\*nominal values (see references for full performance ranges), \*\* anticipated launch date, † denotes a wet mass, ‡ denotes a dry mass, NA = Not Applicable, RF = Radio Frequency

Table 4-13: Propellant-less Propulsion													
Manufacturer	Product	Propellant	Thrust*	Specific Impulse*	Total Impulse*	Mass	Envelope	Power	ACS	PMI Status	Missions	References	
---	---	---	[mN]	[s]	[kN-s]	[kg]	[cm <sup>3</sup> ]	[W]	Y/N	C,D,E,F	---	---	
Aurora Propulsion Technologies <sup>Finland</sup>	Plasma Brake	NA	<100 mN/m	NA	NA	<2	1U	<4	N	E	AuroraSat-1	(139) (140) (141)	
Tethers Unlimited <sup>USA</sup>	NSTT	NA	---	NA	NA	0.81	18 x 18 x 1.8	---	N	F	Prox-1, NPSat-1, DragRacer	(243) (244) (245) (246) (247) (335)	

Note that all data is documented as provided in the references. Unless otherwise published, do not assume the data has been independently verified.  
\*nominal values (see references for full performance ranges), \*\* anticipated launch date, † denotes a wet mass, ‡ denotes a dry mass, NA = Not Applicable  
See Chapter on Passive Deorbit Systems for review of aerodynamic drag devices.



## References

- (1) "NASA Systems Engineering Handbook." NASA/SP-2016-6105, Rev2.
- (2) "NASA Systems Engineering Processes and Requirements." NPR 7123.1C, Effective 14 February 2020, Expiration 14 February 2025.
- (3) JANNAF Spacecraft Propulsion Subcommittee, Micro-Propulsion Panel, "JANNAF Guidelines for the Application of Technology Readiness Levels (TRLs) to Micro-Propulsion Systems." JANNAF 2019, Tampa, FL, Distribution Unlimited
- (4) Marshall, W. M. and M. Deans. "Recommended Figures of Merit for Green Monopropellants." NASA TM-2013-216560. National Aeronautics & Space Administration. Cleveland, OH. August, 2013.
- (5) "AISat-2". <https://directory.eoportal.org/web/eoportal/satellite-missions/a/alsat-2>
- (6) Arianegroup. "Chemical Monopropellant Thruster Family." Product Brochure. <http://www.space-propulsion.com/brochures/hydrazine-thrusters/hydrazine-thrusters.pdf>
- (7) Stratton, J. 2004. "The use of the aerojet MR-103H thruster on the New Horizons mission to Pluto." 55th International Astronautical Congress.
- (8) Aerojet Rocketdyne. "In-Space Propulsion Data Sheets: Monopropellant and Bipropellant Engines." Product Brochure. <https://www.rocket.com/sites/default/files/documents/In-Space%20Data%20Sheets%209.13.19.pdf>
- (9) Moog Space and Defense Group. "Spacecraft Thrusters." Product Brochure. <https://www.moog.com/products/propulsion-controls/spacecraft/thrusters.html>
- (10) Northrop Grumman Website, "Propulsion Products and Services," Accessed: Sept 2022, URL: <https://www.northropgrumman.com/space/propulsion-products-and-services/>
- (11) Robert K. Masse and Benjamin A. Glassy, Low-Vapor-Toxicity Hydrazine Propellant Blends," Joint Meeting of the 49th Combustion (CS), 37th Airbreathing Propulsion (APS), 37th Exhaust Plume and Signatures (EPSS), and 31st Propulsion Systems Hazards (PSHS) Subcommittees; and the 66th JANNAF Propulsion Meeting (JPM) and meeting of the Programmatic and Industrial Base (PIB), June 3 7, 2019.
- (12) Cavender, D., W. Marshall, and A. Maynard. "2018 NASA Green Propulsion Technology Development Roadmap." NASA/TP—2018—219861. National Aeronautics and Space Administration. August, 2018.
- (13) United States Air Force – Air Force Space Command. AFSPCMAN 91-710. "Range Safety User Requirements." 1 July 2004. Certified Current 17 September, 2013.
- (14) Spores, R., Masses, R., Kimbrel, S., McLean, C. AIAA-2013-3849. "GPIM AF-M315E Propulsion System." 49th AIAA/ASME/SAE/ASEE Joint Propulsion Conference & Exhibit. San Jose.
- (15) Mulkey, H., J. Miller, and C. Bacha. "Green Propellant Loading Demonstration at U.S. Range." AIAA-2016-4576. AIAA Propulsion and Energy Forum. Salt Lake City, UT. July 25-27, 2016.
- (16) Friedhoff, P., K. Anflo, M. Persson, and P. Thormahlen. "Growing Constellation of Ammonium Dinitramide (ADN) Based High Performance Green Propulsion (HPGP) Systems." AIAA-2018-4754. AIAA Propulsion and Energy Forum, Cincinnati, OH, July 9-11, 2018.
- (17) ESA Earth Observation Portal, "ELSA-d (End-of-Life Service by Astroscale)-d (demonstration)" <https://directory.eoportal.org/web/eoportal/satellite-missions/content/-/article/elsa-d#dev>
- (18) Astroscale Press Release, "Astroscale's ELSA-d Mission Successfully Completes Complex Rendezvous Operation," <https://astroscale.com/astrocales-elsa-d-mission-successfully-completes-complex-rendezvous-operation/>



- (19) Bradford ECAPS, "Bradford ECAPS Celebrates 10 Years in Orbit," Press Release, ECAPS Website, June 15, 2020.
- (20) Jet Propulsion Laboratory, National Aeronautics and Space Administration. "Lunar Flashlight." [https://www.jpl.nasa.gov/CubeSat/missions/lunar\\_flashlight.php](https://www.jpl.nasa.gov/CubeSat/missions/lunar_flashlight.php).
- (21) National Aeronautics and Space Administration. "Green Propellant Infusion Mission Fires Thrusters for the First Time." [https://www.nasa.gov/directorates/spacetech/home/tdm/gpim\\_fires\\_thrusters\\_for\\_first\\_time](https://www.nasa.gov/directorates/spacetech/home/tdm/gpim_fires_thrusters_for_first_time)
- (22) McLean, C H, W D Deininger, B M Marotta et al. AIAA-2015-3751. "Green Propellant Infusion Mission Program Overview, Status, and Flight Operations." 51st AIAA/ASME/SAE/ASEE Joint Propulsion Conference.
- (23) Masse, R K, M. Allen, E. Driscoll, L. Arrington, S. Schneider, and T. Vasek. AIAA-2016-4577. "AF-M315E Propulsion System Advances & Improvements." 52nd AIAA/SAE/ASEE Joint Propulsion Conference. Salt Lake City, UT., 25-27 July, 2016.
- (24) NASA. 2017. "Cube Quest Challenge Team Spotlight: Cislunar Explorers." [https://www.nasa.gov/directorates/spacetech/centennial\\_challenges/cubequest/cislunar-explorers](https://www.nasa.gov/directorates/spacetech/centennial_challenges/cubequest/cislunar-explorers)
- (25) "Pathfinder Technology Demonstrator, Demonstrating Novel CubeSat Technologies in Low-Earth Orbit", February 2, 2021, [https://www.nasa.gov/directorates/spacetech/small\\_spacecraft/Pathfinder\\_Technology\\_Demonstrator/](https://www.nasa.gov/directorates/spacetech/small_spacecraft/Pathfinder_Technology_Demonstrator/)
- (26) Messier, D. "NASA Selects Tethers Unlimited's HYDROS-C Thruster for First PTD CubeSat Mission." <http://www.parabolicarc.com/2018/06/30/nasa-selects-tuis-hydros-c-thruster-ptd-CubeSat-mission/>
- (27) Satnews, "Rocket Fuel You Can Drink?" 26 January 2021.
- (28) Porter, A., Freedman, M., Grist, R., Wesson, C., and Hanson, M., "Flight Qualification of a Water Electrolysis Propulsion System," 35<sup>th</sup> Small Satellite Conference, Logan, UT, Paper No: SSC21-XI-06, 2021.
- (29) Rainbow, J., "Benchmark Space Systems unveils in-space mobility-as-a-service business," SpaceNews, 23, June, 2021.
- (30) NanoAvionics. "CubeSat Propulsion System EPSS." <https://nanoavionics.com/CubeSat-components/CubeSat-propulsion-system-epss/>
- (31) DawnAerospace. "CubeSat Propulsion Module." Revision B. Product Brochure. <https://static1.squarespace.com/static/5cb46b698d9740673f117259/t/5e3a2caed29b7f336bad9f52/1580870831508/CubeSat+Propulsion+Module+-+Dawn+Aerospace-compressed.pdf>
- (32) Rocket Lab. "The Rocket Lab Kick Stage." <https://www.rocketlabusa.com/electron/kickstage/>
- (33) Rocket Lab. "Rocket Lab successfully circularizes orbit with new Electron kick Stage." <https://www.rocketlabusa.com/news/updates/rocket-lab-successfully-circularizes-orbit-with-new-electron-kick-stage/>
- (34) Robert K. Masse, Ronald A. Spores, May Allen, "AF-M315E Advanced Green Propulsion – GPIM and Beyond," AIAA Propulsion & Energy Forum, Virtual Forum, August 24-26, 2020.
- (35) Plasma Processes, "ASCENT (AF-M315E) Monopropellant Thrusters", 2020.
- (36) Dawn Aerospace, "SmallSat Propulsion thruster – 20N", <https://www.dawnaerospace.com/products/p/smallsat-propulsion>
- (37) Whitmore, S A, S L Merkley, Z S Spurrier, and S D Walker. 2015. "Development of a Power Efficient, Restartable, 'Green' Propellant Thruster for Small Spacecraft and Satellites." 29th Annual AIAA/USU Conference on Small Satellites.



- (38) Bulcher, A. M. and S. A. Whitmore. "A Green Hybrid Thruster Using Moderately Enriched Compressed Air as the Oxidizer." AIAA-2018-4841. AIAA Propulsion and Energy Forum. Cincinnati, OH. July 9-11, 2018. doi: 10.2514/6.2018-4841
- (39) Whitmore, S., Babb, R., Gardner, T., Lloyd, K., Stephens, J., "Pyrolytic Graphite and Boron Nitride as Low-Erosion Nozzle Materials for Long-Duration Hybrid Rocket Testing". AIAA-2020-3740, AIAA Propulsion and Energy Forum, 2020.
- (40) Whitmore, S., Babb, R., Stephens, J., Horlacher, J., "Further Development of Low-Erosion Nozzle Materials for Long-Duration Hybrid Rocket Burns". AIAA Propulsion and Energy Forum, 2021.
- (41) Jens, E., Karp, A., Williams, K., Nakazono, B., Rabinovitch, J., Dyrda, D., and Mechentel, F. "Low Pressure Ignition Testing of a Hybrid SmallSat Motor." AIAA-2019-4009, AIAA Propulsion and Energy Forum, 2019. <https://doi.org/10.2514/6.2019-4009>.
- (42) Simurda, L., Zilliac, G. and Zaseck, C., "High Performance Hybrid Propulsion System for Small Satellites," AIAA-2013-3635, 49th AIAA/ASME/SAE/ASEE Joint Propulsion Conference, 2013.
- (43) Simurda, L, Zilliac, G., "Continued Testing of a High Performance Hybrid Propulsion System for Small Satellites", AIAA-2015-4201, AIAA Propulsion and Energy Forum, 2015.
- (44) Desain, J., Brady, B., Curtiss, T., Hsu-Schouten, A., Fuller, J., Boyer, J.E., McKnight, B., Cortopassi, A., "Advanced Hybrid Rocket Motor Propulsion Unit for CubeSats(PUC)". Aerospace Report No. TOR-2015-03522.
- (45) ROMBUS Rapid Orbital Mobility Bus." Parabilis Space Technologies, datasheet
- (46) Schappell, D T, E Scarduffa, P Smith, and N Solway. AIAA-2005-4055. "Advances in Marotta Electric and Satellite Propulsion Fluid Control Activities." 41st AIAA/ASME/SAE/ASEE Joint Propulsion Conference.
- (47) Hinkley, D. "A Novel Cold Gas Propulsion System for Nanosatellites and Picosatellites." AIAA, 22nd Annual Conference on Small Satellites, SSC08-VII-7.
- (48) Gibbon, D. 2010. "A review of the use of butane as a low-cost propellant." Space Propulsion Conference.
- (49) Gibbon, D. and Underwood, C. "Low Cost Butane Propulsion System for Small Spacecraft," 15th AIAA / USU Conference on Small Satellites. SSC01-XI-1. <https://digitalcommons.usu.edu/cgi/viewcontent.cgi?article=2030&context=smallsat>
- (50) Pauliukonis, R S. 2017. "Fuel system comprising sulfur hexafluoride and lithium containing fuel." <https://patents.google.com/patent/US3325318>.
- (51) Bonin, G, N Roth, S Armitage, J Newman, B. Risi, and R. Zee. 2015. "CanX-4 and CanX-5 Precision Formation Flight: Mission Accomplished!" 29th Annual AIAA/USU Conference on Small Satellites.
- (52) Manzoni, G, and Y L Brama. 2015. "CubeSat Micropropulsion Characterization in Low Earth Orbit." 29th Annual AIAA/USU Conference on Small Satellites.
- (53) GOMSpace. "Attitude and Orbit Control Systems." <https://gomspace.com/shop/subsystems/attitude-orbit-control-systems/default.aspx>
- (54) "GomX-4," <https://directory.eoportal.org/web/eoportal/satellite-missions/g/gomx-4>.
- (55) National Aeronautics & Space Administration. "BioSentinel." Fact Sheet. [https://www.nasa.gov/sites/default/files/atoms/files/biosentinel\\_fact\\_sheet\\_16apr2019\\_508.pdf](https://www.nasa.gov/sites/default/files/atoms/files/biosentinel_fact_sheet_16apr2019_508.pdf)
- (56) Lightsey, E. G., T. Stevenson, and M. Sorgenfrei. "Development and Testing of a 3-D-Printed Cold Gas Thruster for an Interplanetary CubeSat." Proceedings of the IEEE, Vol. 106, No. 3, March, 2018. doi: 10.1109/JPROC.2018.2799898
- (57) Kvell, U, M Puusepp, F Kaminski, and et al. 2014. "Nanosatellite orbit control using MEMS cold gas thrusters." Proceedings of the Estonian Academy of Sciences, 63, 2S, 279–285.



- (58) Palmer, K., Sundqvist, J., Salaverri, A., Gronland, T., Li, Z., and Wu, S.. "In-Orbit Demonstration of a MEMS-based Micropropulsion System for CubeSats." Small Satellite Conference, August 2016.
- (59) Bowen, J, M Villa, and A Williams. 2015. "CubeSat based Rendezvous, Proximity Operations, and Docking in the CPOD Mission." 29th Annual AIAA/USU Conference on Small Satellites.
- (60) VACCO Industries. "CubeSat Propulsion Systems from VACCO." <https://www.CubeSat-propulsion.com/>
- (61) Klesh, A, and J Krajewski. 2015. "MarCO: CubeSats to Mars in 2016." 29th Annual AIAA/USU Conference on Small Satellites.
- (62) Jet Propulsion Laboratory, National Aeronautics and Space Administration. "Mars Cube One (MarCO)." <https://www.jpl.nasa.gov/CubeSat/missions/marco.php>.
- (63) VACCO Industries. "NEA Scout Propulsion System." Product Brochure. <https://www.CubeSat-propulsion.com/wp-content/uploads/2017/08/X16056000-data-sheet-080217.pdf>
- (64) Lockett, T., Castillo-Rogez, J., Johnson, L., Lightholder, J., and Few, A., "Near-Earth Asteroid Scout Flight Mission," IEEE A&E Systems Magazine, March 2020, DOI. No. 10.1109/MAES.2019.2958729
- (65) Editorial, "Iodine Impulse for SmallSats Demo'd On-Orbit by ThrustMe and Spacety," SmallSat News, 25 November 2019.
- (66) Werner, D., "Thrustme, Spacety report initial success of cold gas thruster," SpaceNews, 23 November, 2019.
- (67) Martinez, J., Rafalskyi, D., Aanesland, A., Laurand, X., Martinez, S., and Quinsac, G., "An off-axis iodine propulsion system for the Robusta-3A mission, 34<sup>th</sup> Small Satellite Conference, SSC20-IX-03, 2020.
- (68) ThrustMe, "I2T5 Cold Iodine Thruster," Company Datasheet, Version 02/21, 2021.
- (69) Zondervan, K L, J Fuller, D Rowen, and et al. 2014. "CubeSat Solid Rocket Motor Propulsion Systems Providing Delta-Vs Greater than 500 m/s." 28th Annual AIAA/USU Conference on Small Satellites.
- (70) Nicholas, A, T Finne, I Galysh, A Mai, and J Yen, W. Sawka, J. Ransdell, and S. Williams. 2013. "SpinSat Mission Overview." 27th Annual AIAA/USU Conference on Small Satellites.
- (71) Pacific Scientific Energetic Materials Company (PacSci EMC). Product information website. <https://psemc.com/products/satellite-propulsion-system/>
- (72) BusinessWire.com. 2017. "PacSci EMC Demonstrates First Ever Successful Orbital Maneuvers and Orbit Raising of a CubeSat Using a Commercial Solid Rocket Motor Array." <https://www.businesswire.com/news/home/20170925006504/en/PacSci-EMC-Demonstrates-Successful-Orbital-Maneuvers-Orbit>.
- (73) Hartwig, J.W. "Propellant Management Devices for Low Gravity Fluid Management: Past, Present, and Future Applications." AIAA Journal of Spacecraft and Rockets Vol. 54, No. 4, 808 – 824. 2017.
- (74) W. Tam, G. Kawahara, K. Wlodarczyk, "Review of ATK Diaphragm Tanks-An Update", Space Propulsion 2018, SP2018\_00024.
- (75) Carpenter, C, D Schmuland, J Overly, and R Masse. 2014. "Test Results for the MPS-120 and MPS-130 CubeSat Propulsion Systems." 28th Annual AIAA/USU Conference on Small Satellites. Logan.
- (76) Aerojet Rocketdyne. "Modular Propulsion Systems." Product Brochure. <https://www.rocket.com/sites/default/files/documents/CubeSat%20Mod%20Prop-2sided.pdf>
- (77) Werner, D., "Stellar Exploration propels EchoStar nanosatellite to valuable slot," SpaceNews, August 10, 2021.



- (78) “CAPSTONE Launches to Test New Orbit for NASA’s Artemis Moon Missions,” NASA Press Release, June 28, 2022.
- (79) Stellar Exploration, “Propulsion for Small Spacecraft.” Product Brochure.
- (80) Aerospace Corporation. “Propelling the Field of SmallSats Forward.” <https://aerospace.org/article/propelling-field-small-sats-forward>
- (81) Gagne, K. R., M. R. McDevitt, and D. L. Hitt. “A Dual Mode Propulsion System for Small Satellite Applications.” Aerospace. Vol. 5, No. 52. 2018. doi: 10.3390/aerospace5020052
- (82) Benchmark Space Systems. “B125 SmallSat Bipropellant Thruster.” Product Brochure. <https://www.benchmarkspacesystems.com/b125>
- (83) Bradford ECAPS. “High Performance Green Propulsion.” Product Brochure. [https://www.ecaps.space/assets/pdf/Bradford\\_ECAPS\\_Folder\\_2017.pdf](https://www.ecaps.space/assets/pdf/Bradford_ECAPS_Folder_2017.pdf)
- (84) Bradford ECAPS. “1N GP Thruster.” <https://www.ecaps.space/products-1ngp.php>
- (85) CU Aerospace. “Monopropellant Propulsion Unit for CubeSats (MPUC) System”, Company Website, Datasheet, 2021, URL: <https://cuaerospace.com/products-services/space-propulsion-systems/monopropellant-propulsion-unit-mpuc>
- (86) Tethers Unlimited. “Hydros.” Product Brochure. <http://www.tethers.com/wp-content/uploads/2019/09/2019-HYDROS.pdf>
- (87) Moog, Inc. “Monopropellant Propulsion Module.” Product Brochure. [https://www.moog.com/content/dam/moog/literature/Space\\_Defense/spaceliterature/propulsion/moog-monopropellant-propulsion-module-datasheet.pdf](https://www.moog.com/content/dam/moog/literature/Space_Defense/spaceliterature/propulsion/moog-monopropellant-propulsion-module-datasheet.pdf)
- (88) Tsay, M., C. Feng, and J. Zwahlen. “System-Level Demonstration of Busek’s 1U CubeSat Green Propulsion Module ‘AMAC’.” AIAA-2017-4946. 53rd AIAA/SAE/ASEE Joint Propulsion Conference. Atlanta, GA. 10-12 July, 2017.
- (89) Anflo, K. and B. Crowe. “In-Space Demonstration of an ADN-based Propulsion System.” AIAA-2011-5832. 47th AIAA/ASME/SAE/ASEE Joint Propulsion Conference & Exhibit. San Diego, CA. July 31 – August 3, 2011.
- (90) “SkySat: Quick Facts,” eoPortal, July 26, 2016.
- (91) Busek Co., Inc. “BGT-X5 Green Monopropellant Thruster.” Product Brochure. <http://busek.com/index.htm/files/70008517E.pdf>
- (92) Busek Co., Inc. “Green Monopropellant Thrusters.” [http://busek.com/technologies\\_greenmonoprop.htm](http://busek.com/technologies_greenmonoprop.htm)
- (93) CU Aerospace. “Performance Metrics for CUA Propulsion Systems.” Company Website, Datasheet, 2022. URL: <https://cuaerospace.com/products-services/space-propulsion-systems/monopropellant-propulsion-unit-mpuc>
- (94) King, D., Woodruff, C., Camp, J., and Carroll, D. “Development and Testing of a Low Flame Temperature, Peroxide-Alcohol-Based Monopropellant Thruster.” 35th Small Satellite Conf., Paper # SSC21-S1-41, Logan, UT, Aug. 6-9, 2021.
- (95) NASA, 2015, “Pathfinder Technology Demonstrator.” National Aeronautics & Space Administration. [https://www.nasa.gov/directorates/spacetech/small\\_spacecraft/ptd.html](https://www.nasa.gov/directorates/spacetech/small_spacecraft/ptd.html).
- (96) VACCO Industries. “Green Propulsion System.” Product Brochure. <https://www.CubeSat-propulsion.com/wp-content/uploads/2019/08/X19041000-Green-Propulsion-System-datasheet-073019.pdf>
- (97) VACCO Industries. “Integrated Propulsion System.” Product Brochure. <https://www.CubeSat-propulsion.com/wp-content/uploads/2019/08/Integrated-Propulsion-System-datasheet-080519.pdf>
- (98) VACCO Industries. “ArgoMoon Propulsion System.” Product Brochure. <https://www.CubeSat-propulsion.com/wp-content/uploads/2017/08/X17025000-datasheet-080217.pdf>



- (99) Utah State University. "USU Technology Highlight: GOX and Nitrox Hybrid Green Rocket System." Product Brochure. <http://rqs.usu.edu/techtransfer/hybrid-green-rocket-system/>
- (100) Rabinovitch, J., Jens, E., Karp, A., Nakazono, N., Conte, A., Vaughan, D., "Characterization of PolyMethylMethAcrylate as a Fuel for Hybrid Rocket Motors". AIAA-2018-4530, AIAA Propulsion and Energy Forum, 2018.
- (101) Jens, E., Karp, A., Rabinovitch, J., Nakazono, B., Conte, A., Vaughan, D." Design of Interplanetary Hybrid CubeSat and SmallSat Propulsion Systems." AIAA-2018-4668, AIAA Propulsion and Energy Forum, 2018.
- (102) Dyrda, D., Mechentel, F., Cantwell, B., Karp, A., Rabinovitch, J., Jens, E., "Diode Laser Ignition Testing for PMMA/GOX Hybrid Motors." AIAA-2019-4095, AIAA Propulsion and Energy Forum, 2019.
- (103) Nano OTS Nanosatellite Orbital Transfer System", Parabilis Space Technologies, datasheet
- (104) Digital Solid State Propulsion, Inc. (DSSP) "CAPS-3." Product Brochure. <https://dsspotech.com/propellant-products>
- (105) DSSP. "MPM-7." Product Brochure. <https://dsspotech.com/propellant-products>
- (106) DSSP. "CDM-1." Product Brochure. <https://dsspotech.com/propellant-products>
- (107) Thrasher, J. and M. McPherson. "Design and Qualification of DSSP's CubeSat Delta-V Motor (CDM-1)." Digital Solid State Propulsion, Inc. Poster presented at Small Satellites Conference. Logan, UT. 2015. <https://digitalcommons.usu.edu/cgi/viewcontent.cgi?article=3261&context=smallsat>
- (108) Industrial Solid Propellant, Inc. "Product Portfolio." Product Brochure. <http://www.specificimpulse.com/>
- (109) Alliant Techsystems Inc. (ATK). "ATK Space Propulsion Products Catalog." Product Brochure. 2008. Available from: <https://forum.nasaspaceflight.com/index.php?action=dlattach;topic=31042.0;attach=494063;sess=0>
- (110) D-Orbit. "D-Raise." Product Brochure. <https://www.dorbit.space/d-raise>
- (111) D-Orbit. "D3." Product Brochure. <https://www.dorbit.space/d3>
- (112) VACCO Industries. "Standard Propulsion System." Product Brochure. <https://www.CubeSat-propulsion.com/wp-content/uploads/2019/08/Standard-MiPS-datasheet-080119.pdf>
- (113) VACCO Industries. "JPL MarCO – Micro CubeSat Propulsion System." Product Brochure. [https://www.CubeSat-propulsion.com/wp-content/uploads/2015/11/X14102000-01\\_2019update.pdf](https://www.CubeSat-propulsion.com/wp-content/uploads/2015/11/X14102000-01_2019update.pdf)
- (114) VACCO Industries. "Reaction Control Propulsion Module." Product Brochure. <https://www.CubeSat-propulsion.com/wp-content/uploads/2015/10/Reaction-control-propulsion-module.pdf>
- (115) Moog, "Cold Gas Thrusters," Moog Datasheet, 2021
- (116) GOMspace. "NanoProp CGP-3." Product Brochure. [https://gomspace.com/UserFiles/Subsystems/flyer/gomspace\\_nanoprop\\_cgp3.pdf](https://gomspace.com/UserFiles/Subsystems/flyer/gomspace_nanoprop_cgp3.pdf)
- (117) GOMspace. "NanoProp 6U." Product Brochure. [https://gomspace.com/UserFiles/Subsystems/flyer/gomspace\\_nanoprop\\_cgp6\\_flyer.pdf](https://gomspace.com/UserFiles/Subsystems/flyer/gomspace_nanoprop_cgp6_flyer.pdf)
- (118) Newman, J and Zee, R. E. "Drift Recovery and Station Keeping Results for the Historic CanX-4/CanX-5 Formation Flying Mission." 29<sup>th</sup> Annual AIAA/USU Conference on Small Satellites, Logan, UT, 2015.
- (119) Risi, B.W. "Propulsion System Development for the CanX-4 and CanX-5 Dual Nanosatellite Formation Flying Mission." Master of Applied Science Thesis, University of Toronto, 2014.
- (120) Jahn, R. G. and Choueiri, E. Y. "Electric Propulsion." Academic Press, Encyclopedia of Physical Science and Technology, Third Edition, Volume 5, 2002.



- (121) Goebel, D. M. and Katz, I. "Fundamentals of Electric Propulsion: Ion and Hall Thrusters." California Institute of Technology, Jet Propulsion Laboratory, JPL Space Science and Technology Series, 2008.
- (122) Bradford Space, "Comet: Water-based Propulsion for Small Satellites." Company Website, Datasheet, Copyright 2019.
- (123) Sarda, K., Roth, N., Zee, R. E., Cajacob, D., and Orr, N. G. "Making the Invisible Visible: Precision RF-Emitter Geolocation from Space by the HawkEye 360 Pathfinder Mission." 32<sup>nd</sup> AIAA/USU Conference on Small Satellites, Logan, UT, 2018.
- (124) eoPortal, "HawkEye 360 Pathfinder Cluster Mission to identify RFI locations." June, 2020. URL: <https://directory.eoportal.org/web/eoportal/satellite-missions/h/hawkeye>
- (125) BlackSky Global, "Global-4 Orbital Debris Assessment Report (ODAR)." FCC Licensing, 18 December, 2018.
- (126) CU Aerospace, "Propulsion Unit for CubeSats." Company Website, URL: <https://cuaerospace.com/products-services/space-propulsion-systems/propulsion-unit-for-cubesats-puc>, Datasheet, 2020.
- (127) Carroll, D. L., Cardin, J. M., Burton, R. L., Benavides, G. F., Hejmanowski, N., Woodruff, C., Bassett, K., King, D., Laystrom-Woodard, J., Richardson, L., Day, C., Hageman, K., and Bhandari, R. "Propulsion Unit for CubeSats (PUC)." 62nd JANNAP Propulsion Meeting, Nashville, TN, 1-5 June, 2015, Paper Tracking # 4059, 2015, Dist. A.
- (128) Burton, R.L., Benavides, G.F., and Carroll, D.L. "Space Thruster using Robust Microcavity Discharge." U.S. Patent No. 9,242,747 B1, 2016.
- (129) Woodruff, C., Carroll, D., King, D., Burton, R., and Hejmanowski, N. "Monofilament Vaporization Propulsion (MVP) – CubeSat propulsion system with inert polymer propellant." Small Satellite Conf., Paper # SSX18-III-09, Logan, UT, Aug. 6-9, 2018.
- (130) CU Aerospace, "Monofilament Vaporization Propulsion System Solid Inert Polymer Propellant." Company Website, URL: <https://cuaerospace.com/products-services/space-propulsion-systems/monofilament-vaporization-propulsion-mvp>, Datasheet, 2020.
- (131) Woodruff, C., Parta, M., King, D., Woodruff, A., Burton, R., and Carroll, D. "Monofilament Vaporization Propulsion (MVP) Flight-like System Performance." 37th International Electric Propulsion Conference (IEPC) 2022, Boston, Massachusetts, Paper # IEPC 2022-575, 2022.
- (132) Woodruff, C., King, D., Burton, R., Bowman, J., and Carroll, D. "Development of a Fiber-Fed Pulsed Plasma Thruster for Small Satellites." Small Satellite Conference, Logan, UT, Paper # SSC19-WKVIII-06, 2019.
- (133) Woodruff, C., King, D., Burton, R., and Carroll, D. "Fiber-fed Pulsed Plasma Thruster for Small Satellites." 36th International Electric Propulsion Conference (IEPC) 2019, Vienna, Austria, Paper # IEPC 2019-A899, 2019.
- (134) Woodruff, C., King, D., Burton, R., and Carroll, D. "Fiber-Fed Advanced Pulsed Plasma Thruster (FPPT)." U.S. Patent # 10,570,892, Feb. 25, 2020, and 11,242,844, Feb. 8, 2022.
- (135) Woodruff, C., Parta, M., King, D., Burton, R., and Carroll, D. "Fiber-Fed Pulsed Plasma Thruster (FPPT) with Multi-axis Thrust Vectoring." 37th International Electric Propulsion Conference (IEPC) 2022, Boston, Massachusetts, Paper # IEPC 2022-558, 2022.
- (136) CU Aerospace, "Fiber-Fed Pulsed Plasma Thruster System Solid Inert Polymer Propellant." Company Website, URL: <https://cuaerospace.com/products-services/space-propulsion-systems/fiber-fed-pulsed-plasma-thruster-fppt>, Datasheet, 2022.
- (137) "NASA Funds Long-Standing Partners in CubeSat Development." Press Release, University of Illinois at Urbana/Champaign, Aerospace Engineering, 9 Oct., 2019.





- (138) Aurora Propulsion Technologies, “ARM-A Datasheet.” Company Website, URL: <https://aurorapt.fi/thrusters/>, Datasheet, Copyright May, 2021.
- (139) Aurora Propulsion Technologies, “Deorbiting Old Satellites & Used Rockets with Aurora Plasma Brake.” Company Website, URL: <https://aurorapt.fi/deorbiting/#plasmabrake>, Brochure, Copyright March, 2022
- (140) “Aurora Successfully Launches First Sustainable Propulsion Tech Demonstration,” Aurora Propulsion Technologies, Press Release, May 3, 2022.
- (141) “The Flying Object (AuroraSat-1, Aurora CubeSat),” Nanosats Database, URL: <https://www.nanosats.eu/sat/aurorasat-1>, Updated July 23, 2022.
- (142) “Collision Avoidance for CubeSats and SmallSats with ARM-C,” Aurora Brochure, Company Website, Dated March 21, 2022.
- (143) Ziemer, J., Marrese-Reading, Colleen, Cutler, C., Dunn, C., Romero-Wolf, A., Javidnia, S., Le, T., Li, I., Barela, P., Demmons, N., Hruby, V., Slutsky, J., Thorpe, J., Maghami, P., Hsu, O., and O’Donnell, J. “In-Flight Verification and Validation of Colloid Microthruster Performance.” AIAA Propulsion and Energy Forum, Cincinnati, OH, AIAA-2018-4643.
- (144) Krejci, D., Reissner, A., Seifert, B., Jelem, D., Horbe, T., Plesescu, F., Friedhoff, P., and Lai, S. “Demonstration of the IFM Nano FEEP Thruster in Low Earth Orbit.” 4S Symposium, 2018.
- (145) Krejci, D., Reissner, A., Schonherr, T., Seifert, B., Saleem, Z., and Alejos, R. “Recent Flight Data from IFM Nano Thrusters in a Low Earth Orbit.” 36<sup>th</sup> IEPC, Vienna, Austria, IEPC-2019-A724.
- (146) Amos, J. “ICEYE’s Small Radar Satellites Achieve Big Capability.” BBC News, 6 May, 2020, URL: <https://www.bbc.com/news/science-environment-52560809>
- (147) Werner, D. “Key Hurdle Cleared for York Space Systems and U.S. Army Small Satellite Launch.” SpaceNews, 22 February, 2018, URL: <https://spacenews.com/key-hurdle-cleared-for-york-space-systems-and-u-s-army-small-satellite-launch/>
- (148) Clark, S. “Rocket Lab Deploys Experimental U.S. Military SmallSats on First Night Launch.” Spaceflight Now, 5 May, 2019. URL: <https://spaceflightnow.com/2019/05/05/rocket-labs-deploys-experimental-u-s-military-SmallSats-on-first-night-launch/>
- (149) Wörner, N. “Sensor Networks of Satellites.” ElektronikNet, 26 May, 2020. URL: <https://www.elektroniknet.de/international/sensor-networks-of-satellites-176831.html>
- (150) “NetSat – Pioneering Research in Formation Control”, website accessed June 2021, <https://www.telematik-zentrum.de/en/projects/netsat/>
- (151) D. Krejci and A. Reissner, “The First 100 FEEP Propulsion Systems in Space: A Statistical View and Lessons Learnt of 4 Years of ENPULSION”, IEPC-2022-199, 37th International Electric Propulsion Conference, Cambridge, MA, 19-23 June 2022.
- (152) Grimaud, L., Schonherr, T., Vasiljevich, I., Reissner, A., Krejci, D., and Seifert, B., “Qualification status update of the MICRO R3 and NANO R3 FEEP thrusters,” IEPC-2022-200, 37th International Electric Propulsion Conference, Cambridge, MA, 19-23 June 2022.
- (153) “First Use of the Enpulsion Micro R3 Thruster in the GMS-T Mission”, Space Daily, 18 March 2021.
- (154) Bangert, P., Kramer, A., and Schilling, K. “UWE-4: Integration State of the First Electrically Propelled 1U CubeSat.” 31<sup>st</sup> Annual AIAA/USU Conference on Small Satellites, SSC17-WK-47, 2017.
- (155) Kramer, A., Bangert, P., and Schilling, K. “Hybrid Attitude Control On-Board UWE-4 Using Magnetorquers and the Electric Propulsion System NanoFEEP.” 33<sup>rd</sup> Annual AIAA/USU Conference on Small Satellites, SSC19-WKI-02, 2019.



- (156) D. Werner, “Miniature Thruster Propels Single CubeSat to Lower Orbit”, SpaceNews, 22 July 2020, <https://spacenews.com/uwe-4-lowers-altitude/>
- (157) “Accion Systems TILE 2 In-Space Propulsion System to Launch on the June 2021 SpaceX Rideshare with Astro Digital and Starfish Space”, press release, 19 April 2021, <https://accion-systems.com/news/press/accion-systems-tile-2-in-space-propulsion-system-to-launch-on-the-june-2021-spacex-rideshare-with-astro-digital-and-starfish-space/>
- (158) Kanayama, L. “SpaceX and NASA Launch CRS-25 Mission to the ISS”, NASA Spaceflight, 14 July 2022.
- (159) Satnews, “Two NanoAvionics-Built SmallSats were Passengers on the SpaceX Transporter-2 Mission Launched to Successful Orbit,” 6 July 2021.
- (160) “Accion Systems to demonstrate its propulsion system in NanoAvionics US rideshare mission”, press release, 12 October 2020, <https://accion-systems.com/news/press/accion-systems-to-demonstrate-its-propulsion-system-in-nanoavionics-us-rideshare-mission/>
- (161) “Accion Systems’ Next-Gen TILE Propulsion System Raises Commercial Satellite Orbit for the First Time”, press release, 1 August 2022.
- (162) N. Arthur. “Ion Thruster Produced Roll Torque.” AIAA-2019-4166.
- (163) N. Wallace et al., “The GOCE Ion Propulsion Assembly – Lessons Learnt from the First 22 Months of Flight Operations”, IEPC-2011-327.
- (164) “ESA’s GOCE Mission Comes to an End”, ESA press release #33-2013, 21 Oct 2013, [https://www.esa.int/Newsroom/Press\\_Releases/ESA\\_s\\_GOCE\\_mission\\_comes\\_to\\_an\\_end](https://www.esa.int/Newsroom/Press_Releases/ESA_s_GOCE_mission_comes_to_an_end)
- (165) A. Jones, “French Startup Demonstrates Iodine Propulsion in Potential Boost for Space Debris Mitigation Efforts”, SpaceNews, 22 January 2021, <https://spacenews.com/french-startup-demonstrates-iodine-propulsion-in-potential-boost-for-space-debris-mitigation-efforts/>
- (166) “Trial Integration Completed By Norwegian Space Agency Of ThrustMe’s Propulsion System For NorSat-TD”, SatNews, 27 April 2021, <https://news.satnews.com/2021/04/27/trial-integration-completed-by-norwegian-space-agency-of-thrustmes-propulsion-system-for-norsat-td/>
- (167) “ESA and GomSpace Sign Contract for Continuation of the GOMX-5 Mission”, GomSpace press release, 2 October 2020, <https://news.cision.com/gomspace-a-s/r/esa-and-gomspace-sign-contract-for-continuation-of-the-gomx-5-mission,c3202464>
- (168) Malphrus, B. “The Lunar IceCube EM-1 Mission: Prospecting the Moon for Water Ice.” IEEE Aerospace and Electronic Systems Magazine, Vol 34, Issue 4, DOI: 10.1109/MAES.2019.2909384.
- (169) Clark, P. “Lunar Ice Cube Mission: Determining Lunar Water Dynamics with a First Generation Deep Space CubeSat.” 47<sup>th</sup> Lunar and Planetary Science Conference, 2016.
- (170) Hardgrove, C. “The Lunar Polar Hydrogen Mapper CubeSat Mission.” IEEE Aerospace and Electronic Systems Magazine, Vol 35, Issue 3, DOI: 10.1109/MAES.2019.2950747.
- (171) eoPortal, “SMART-1 (Small Mission for Advanced Research in Technology.” June, 2020. URL: <https://directory.eoportal.org/web/eoportal/satellite-missions/s/smart-1>
- (172) eoPortal, “TacSat-2 / Roadrunner.” June 2020. URL: <https://earth.esa.int/web/eoportal/satellite-missions/content/-/article/tacsat2>
- (173) de Grys, K., Mathers, A., Welander, B., and Khayms, V. “Demonstration of 10,400 Hours of Operation on a 4.5 kW Qualification Model Hall Thruster.” 46<sup>th</sup> AIAA Joint Propulsion Conference, Nashville, TN, July, 2010.
- (174) Sheetz, M. and Petrova, M. “Why in the next decade companies will launch thousands more satellites than in all of history.” CNBC, 15 December, 2019. URL:



- <https://www.cnbc.com/2019/12/14/spacex-oneweb-and-amazon-to-launch-thousands-more-satellites-in-2020s.html>
- (175) Gorbunov, A., Khodnenko, V., Khromov, A., Murashko, V., Koryakin, A., Zhosan, V., and Grikhin, G. “Vernier Propulsion System for Small Earth Remote Sensing Satellite “Canopus-V.” 32<sup>nd</sup> IEPC, Wiesbaden, Germany, 2011.
- (176) eoPortal, “Kanopus-V 1 (Kanous-Vulkan N1, Environmental Satellite).” June, 2020. URL: <https://directory.eoportal.org/web/eoportal/satellite-missions/k/kanopus-v-1>
- (177) eoPortal, “Kanopus-V-IK 1 (Kanous-Vulkan-Infra-Krasny-1).” June, 2020. URL: <https://directory.eoportal.org/web/eoportal/satellite-missions/k/kanopus-v-ik-1>
- (178) EDB Fakel, “Stationary Plasma Thrusters.” Company Website, Datasheet, 2020.
- (179) Gnizdor, R., Markov, A., Mitrofanova, O., and Semenenko, D. “The research of the modified SPT-70 thruster parameters and characteristics.” 36<sup>th</sup> IEPC, Vienna, Austria, 2019.
- (180) Hruby, P., Demmons, N., Courtney, D., Tsay, M., Szabo, J., and Hruby, V. “Overview of Busek Electric Propulsion.” 36<sup>th</sup> IEPC, Vienna, Austria, 2019.
- (181) Kamhawi, H., Haag, T., Benavides, G., Hickman, T., Smith, T., Williams, G., Myers, J., Polzin, K., Dankanich, J., Byrne, L., Szabo, J., and Lee, L. “Overview of Iodine Propellant Hall Thruster Development Activities at NASA Glenn Research Center.” 52<sup>nd</sup> AIAA Joint Propulsion Conference, Salt Lake City, Utah, 2016.
- (182) Busek, “BHT-350 Hall Effect Thruster,” Company Datasheet, Copyright 2021.
- (183) Busek, “Busek Scales Thruster Production for Airbus OneWeb Satellites,” Company Press Release, June 22, 2022.
- (184) NASA TechPort, “Iodine Satellite (iSAT).” June, 2020. URL: <https://techport.nasa.gov/view/91492>
- (185) Lev, D., Zimmerman, R., Shoor, B., Appel, L., Ben-Ephraim, M., Herscovitz, J., and Epstein, O. “Electric Propulsion Activities at Rafael in 2019.” 36<sup>th</sup> IEPC, Vienna, Austria, 2019.
- (186) Lev, D., Franco, D., Zimmerman, R., Tordjman, M., Auslender, B., and Epstein, O., “96 kN-sec Endurance Test of the R-200 Low Power Hall Thruster,” 37<sup>th</sup> IEPC, Boston, MA, Paper No: IEPC-2022-399, 19-23, June 2022.
- (187) Lev, D., Franco, D., Auslender, B., and Epstein, O., “Extension of the Operation Envelope of the R-200 Low Power Hall Thruster,” 37<sup>th</sup> IEPC, Boston, MA, Paper No: IEPC-2022-357, 19-23, June 2022.
- (188) Herscovitz, J., and Karnieli, A. “VENUS Program: Broad and New Horizons for Super-Spectral Imaging and Electric Propulsion Missions for a Small Satellite.” 22<sup>nd</sup> AIAA/USU Conference on Small Satellites, Logan, Utah, 2008.
- (189) Herscovitz, J., Appel, L., Barnett, D., Baron, D., Davidson, A., Gontmacher, P., Kedem, M., Lev, D., Merenstein, A., Rbinovich, L., Reiner, D., Salama, O., Amit-Shapira, Y., Shechter, Y., Shoor, B., Warshavsky, A., and Zhuravel, N. “VENUS – A Novel Technological Mission Using Electric Propulsion.” 35<sup>th</sup> IEPC, Atlanta, Georgia, 2017.
- (190) Herscovitz, J., Lev, D., Shoor, B., Katz-Franco, D., Berkman, S., Baron, D., and Adler, S. “VENUS – Updates on Technological Mission using the Israeli Hall Effect Thruster (IHET).” 36<sup>th</sup> IEPC, Vienna, Austria, 2019.
- (191) eoPortal “VENUS (Vegetation and Environment monitoring on a New Microsatellite).” June, 2020. URL: <https://directory.eoportal.org/web/eoportal/satellite-missions/v-w-x-y-z/venus>
- (192) Appel, L., Medvinsky, G., Shoor, B., Sirota, A., Zimmerman, R., Lev, D., Epstein, O., “Integration Test of the R-800 Low Power Hall Thruster Electric Propulsion System,” 37<sup>th</sup> IEPC, Boston, MA, Paper No: IEPC-2022-358, 19-23, June 2022.
- (193) SITAEL “Electric Propulsion – HT100 Hall Effect Thruster Product Sheet.” Company Website, Datasheet, 2020.



- (194) Misuri, T., Ducci, C., Gregucci, S., Pedrini, D., Cannelli, F., Cesari, U., Nania, F., Vicini, A., Pace, G., Magistro, F., Cenni, J., Dignani, D., Farauanu, C., Quaranta, V., Tiseo, B., Orefice, M., and Bruno, G. "SITAEL HT100 Thruster Unit, Full Ground Qualification." 36<sup>th</sup> IEPC, Vienna, Austria, 2019.
- (195) Tambini, A., Antonini, F., Melega, N., Mariotti, G., Centonze, V., and Gabriele, A. "uHETSat small Power System for high demanding payloads." European Space Power Conference, 2019.
- (196) Astra, "Astra Spacecraft Engine (Krypton/Xenon Propulsion System." Company Website, June 2022, Version 4.
- (197) Gill, M., Martinez, R., Zannos, A., Bailey, T., Cassidy, M., Cooney, J., Crawford, A., Cuadra, J., Delgado, J., Fuller, J., Haverty, M., Hopkins, M., Keyes, E., Lee, L, Massey, D., McClellan, K., Pittman, J., Schmidt, M., Shiyani, D., and Sorel, T., "On-Orbit Data and Validation of Astra's ACE Electric Propulsion System," 36<sup>th</sup> Annual Small Spacecraft Conference, Logan, UT, Paper No.: SSC22-S2-08, 2022.
- (198) Spaceflight, "Sherpa Program: New Orbital Transfer Vehicles Launch Smallsats to Custom Orbital Destination," Spaceflight Website, URL: <https://spaceflight.com/sherpa/#sherpalte>, Accessed October 2022.
- (199) Foust, J., "Astra to sell electric thrusters to Airbus OneWeb Satellites," SpaceNews, August 30, 2022.
- (200) Foust, J., "Astra wins order for electric thrusters from LeoStella," SpaceNews, April 12, 2022.
- (201) Exotrail, "Hall effect thruster for small satellites." Company Website, Online Datasheet, May, 2022.
- (202) Exotrail Press Release, "Exotrail delivers its first Hall Effect Propulsion system prototype for In-Orbit Demonstration mission." 02 October, 2019.
- (203) Exotrail Press Release, "Exotrail secures contract with AAC Clyde Space to equip their spacecrafts for Eutelsat's ELO 3 and 4." 18 February, 2020.
- (204) Gurciullo, A., Jarrige, J., Lascombes, P., and Packan, D. "Experimental performance and plume characterization of a miniaturized 50W Hall thruster." 36<sup>th</sup> IEPC, Vienna, Austria, 2019.
- (205) ExoTrail Press Release, "Exotrail paves the way for new space mobility with first of its kind successful in-orbit demonstration mission," 01 January 2021.
- (206) Moriconi, B., Hallouin, T., Gurciullo, A., "Hall Thruster ExoMG<sup>TM</sup> - micro, ExoMG<sup>TM</sup> - nano and low current cathode development at Exotrail: cyclic life testing results." 37<sup>th</sup> IEPC, Cambridge, USA, 2022.
- (207) Aerospacelab Press Release, "Press release – Arthur, Aerospacelab launched the first Belgian private commercial satellite", 30 June 2021.
- (208) Exotrail Press Release, "York Space Systems tackled Exotrail electric propulsion system for its Cislunar mission", 08 September 2021.
- (209) Exotrail Press Release, "OHb LUXSPACE inks contract with exotrail for ExoMG<sup>TM</sup> electric propulsion system onboard triton-x heavy platform.", 23 November 2021.
- (210) Exotrail Press Release, "Exotrail to debut its SpaceVan<sup>TM</sup> in-space mobility service on October 2023 SpaceX Falcon 9 mission", 12 April 2022.
- (211) ExoTerra Resource, "Halo Hall-Effect Thruster." Company Website, Datasheet, April, 2022.
- (212) VanWoerkom, M., Gorokhovskiy, V., Pulido, G., Pettigrew, R., and Seidcheck, A. "Test Results of ExoTerra's Halo Micro Electric Propulsion System." 36<sup>th</sup> IEPC, Vienna, Austria, 2019.
- (213) NASA Press Release, "NASA Announces New Tipping Point Partnerships for Moon and Mars Technologies." 27 September, 2019.



- (214) Glascock, M. S., Kiefer, E., and VanWoerkom, M.; “Performance and Capability Overview of the Halo Electric Propulsion System”, International Electric Propulsion Conference, IEPC-2022-301, 2022.
- (215) Glascock, M. S. and VanWoerkom, M., “Channel Erosion Measurements and Predictions in a 400 W Hall Thruster,” International Electric Propulsion Conference, IEPC-2022-300, 2022.
- (216) Werner, D., “ExoTerra to provide Blackjack Satellite thrusters,” SpaceNews, 30 August, 2021.
- (217) Exoterra Resource, “Halo 12 Hall-Effect Thruster EP Subsystem,” Company Datasheet, Dated April 23, 2022.
- (218) Virgin Orbit, “Exoterra, Virgin Orbit Win NASA Phase II SBIR Award for Solar Electric Propulsion Upper Stage,” Company Press Release, June 1, 2021.
- (219) Nikrant, A., Glogowski, M., Cochran, D., Moquin, T., Choi, Y., Benavides, G., Kamhawi, H., Sarver-Verhey, T., Baird, M., Rhodes, C., and Mackey, J., “Overview and Performance Characterization of Northrop Grumman’s 1kW Hall Thruster String,” 37<sup>th</sup> IEPC, Boston, MA, Paper No. IEPC-2022-303, 19-23 June, 2022.
- (220) Erwin, S., “Northrop Grumman says customers are ‘lined up’ for on-orbit satellite servicing,” SpaceNews, 24 March, 2022.
- (221) Jewett, R., “Optus Orders Mission Extension Pod from Northrop Grumman’s SpaceLogistics,” Via Satellite Article, 22 February, 2022.
- (222) NASA, “Small Spacecraft Electric Propulsion Opens New Deep Space Opportunities,” NASA Press Release, 19 April, 2022.
- (223) Vinoski, J. “Orbion’s Plasma Rocket Thrusters Will Power AST’s New Space-Based Cell Tower.” Forbes, 23 July, 2020.
- (224) Henry, C. “Megaconstellation startup raises \$110 million to connect smartphones via satellite.” SpaceNews, 5 March, 2020.
- (225) Jewett, R., “AST SpaceMobile to Launch Demo Satellite With SpaceX,” Via Satellite, 30 July 2021.
- (226) Erwin, S., “Blue Canyon selects Orbion electric thrusters for DARPA’s Blackjack satellites,” SpaceNews, 15 September 2020.
- (227) Werner, D., “Orbion to supply propulsion for General Atomics weather satellite,” SpaceNews, 24 June, 2022.
- (228) Busek Co Press Release, “Busek Ships First LEO to GEO Capable Electric Propulsion System – Design Demonstrated One Million Newton-Seconds in NASA-Led Test,” PR Newswire, 23 February 2021.
- (229) Szabo, J., Byrne, L., Strain, M., Paintal, S., Sawyer, S., Yu, T., Kolencik, G., and Hruby, V., “One Million Newton-Second Duration Test of a 600 Watt Hall Effect Thruster Fueled By Xenon,” 2020 AIAA Propulsion and Energy Forum, Virtual Event, August 24-28, 2020.
- (230) Burton, R. “Pulsed Plasma Thrusters.” In Encyclopedia of Aerospace Engineering (eds R. Blockley and W. Shyy). doi:[10.1002/9780470686652.eae120](https://doi.org/10.1002/9780470686652.eae120).
- (231) Kolbeck, J., Anders, A., Beillis, I., and Keidar, M. “Micro-propulsion based on vacuum arcs.” Journal of Applied Physics, June, 2019, <https://doi.org/10.1063/1.5081096>.
- (232) J. Foust, “Phase Four Launches First Plasma Propulsion Systems”, SpaceNews, 25 January 2021, <https://spacenews.com/phase-four-launches-first-plasma-propulsion-systems/>
- (233) Debra Werner “Capella Space and Phase Four reveal Maxwell Engine performance” SpaceNews 30 June 2021.
- (234) REGULUS, 6 May 2020, URL: <https://www.t4innovation.com/wp-content/uploads/2020/05/T4i-REGULUS-Magazine.pdf>



- (235) Bellomo, N. "Enhancement of Microsatellites' Mission Capabilities: Integration of REGULUS Electric Propulsion Module into UniSat-7." 70<sup>th</sup> International Astronautical Congress, Washington, D.C., October, 2019.
- (236) "Cube Quest Challenge NASA Facts." NASA, FS-2019-12-073-MSFC. URL: [https://www.nasa.gov/sites/default/files/atoms/files/cubequest\\_fs\\_june2020\\_508.pdf](https://www.nasa.gov/sites/default/files/atoms/files/cubequest_fs_june2020_508.pdf)
- (237) "Three DIY CubeSats Score Rides on NASA's First Flight of Orion, Space Launch System." NASA Press Release 17-055, 8 June, 2017. URL: <https://www.nasa.gov/press-release/three-diy-CubeSats-score-rides-on-nasa-s-first-flight-of-orion-space-launch-system>
- (238) Alhorn, D., Casas, J., Agasid, E., Adams, C., Laue, G., Kitts, C., and O'Brien, S. "NanoSail-D: The Small Satellite That Could!" SmallSat Conference, 2011.
- (239) Mansell, J., Spencer, D., Plante, B., Diaz, A., Fernandez, M., Bellardo, J., Betts, B., and Nye, B. "Orbit and Attitude Performance of the LightSail 2 Solar Sail Spacecraft." AIAA 2020-2177.
- (240) "CubeSail." Laboratory for Advanced Space Systems at Illinois (LASSI), Accessed 5 July, 2020. URL: <https://aerospace.illinois.edu/research/research-facilities/laboratory-advanced-space-systems-illinois-lassi>
- (241) CU Aerospace Press Release, "CubeSail Mission Update," 8 April, 2021. URL: <https://cuaerospace.com/news/details/cubesail-mission-update>
- (242) Johnson, L, et al. "Near Earth Asteroid Scout: Exploring Asteroid 1991VG Using a SmallSat." *Proceedings of the 70<sup>th</sup> International Astronautical Congress*, IAC-19/B4/2.
- (243) "AE's Prox-1 Satellite Launches from Kennedy Space Center." Georgia Institute of Technology, 25 June, 2019. URL: <https://ae.gatech.edu/news/2019/06/aes-prox-1-satellite-launches-kennedy-space-center>
- (244) C. Henry. "Tethers Unlimited Says Early Results of Deorbit Hardware Test Promising." SpaceNews, 23 January, 2020. URL: <https://spacenews.com/tethers-unlimited-says-early-results-of-deorbit-hardware-test-promising/>
- (245) Clark, S. "SmallSat Companies Teaming Up on Deorbit Experiment." Spaceflight Now, 15 August, 2019. URL: <https://spaceflightnow.com/2019/08/15/SmallSat-companies-teaming-up-on-deorbit-experiment/>
- (246) Satnews, "SmallSat Space Debris Remediation Technology Being Demo'd By Millennium Space Systems," 7 December 2020.
- (247) Stankey, H. and Hoyt, R., "In-Flight Performance of the Terminator Tape End-of-Life Deorbit Module," 35<sup>th</sup> Small Satellite Conference, Logan, UT, Paper No: SSC21-XI-03, 2021.
- (248) Busek Company, "Busek Micro Resistojet." Company Website, Datasheet, Copyright 2013.
- (249) Hejmanowski, N. J., Woodruff, C. A., Burton, R. L., Carroll D. L., Palla, A. D., and Cardin J. M. "CubeSat High Impulse Propulsion System (CHIPS) Design and Performance." 63rd JANNAF Propulsion Meeting, Paper Tracking # 4800, Phoenix, AZ, 2016, Dist. A.
- (250) Hejmanowski, N. J., Woodruff, C. A., Burton, R. L., and Carroll D. L. "Electrothermal Space Thruster Heater for Decomposable Propellants." U.S. Patent # 9,909,574 B1, 2018.
- (251) Hejmanowski, N. J., Woodruff, C., Burton, R.L., Carroll, D.L., and Cardin, J. "CubeSat High Impulse Propulsion System (CHIPS)." 62nd JANNAF Propulsion Meeting, Paper Tracking # 4032, Nashville, TN, 1-5 June, 2015, Dist. A.
- (252) CU Aerospace, "CubeSat High Impulse Propulsion System." Company Website, URL: <https://cuaerospace.com/products-services/space-propulsion-systems/cubesat-high-impulse-propulsion-chips>, Datasheet, 2022.



- (253) Cifali, G., Gregucci, S., Andreussi, T., and Andrenucci, M. "Resistojet Thrusters for Auxiliary Propulsion of Full Electric Platforms." 35<sup>th</sup> International Electric Propulsion Conference, Atlanta, GA, IEPC-2017-371, 2017.
- (254) Sitael, "XR Resistojet Product Family." Datasheet, Company Website, Copyright 2015.
- (255) Courtney, D., Wright, P., Lafko, D., Metivier, E., and Demmons, N. "Electrospray Propulsion for Precise Attitude and Position Control." AAS 17-088, Breckenridge, CO., 2017.
- (256) D. Courtney et al. "Electrospray Thrusters for Small Spacecraft Control: Pulsed and Steady State Operation." AIAA-2018-4654.
- (257) Courtney, D., Wood, Z., and Fedkiw, T. "Reconstructing Electrospray Plume Current Spatial Distributions Using Computed Tomography." 36<sup>th</sup> IEPC, Vienna, Austria, IEPC-2019-A-787.
- (258) D. Courtney et al. "High-Speed Transient Characterization of the Busek BET-300-P Electrospray Thruster." 36<sup>th</sup> IEPC, Vienna, Austria, IEPC-2019-A-788.
- (259) T. Fedkiw, Z. Wood, and N. Demmons, "Environmental and Lifetime Testing of the BET-300-P Electrospray Thruster", AIAA 2020-3614.
- (260) Demmons, N., et al., "Qualification of the BET-MAX Electrospray Propulsion System", IEPC-2022-196, 37th International Electric Propulsion Conference, Cambridge, MA, 19-23 June 2022.
- (261) Busek, "BET-MAX Electrospray Thruster System", Company Datasheet, Dated August 2021.
- (262) Enpulsion, "IFM Nano Thruster." Company Website, Datasheet ENP2018-001.F.1, Accessed 2020.
- (263) Schönherr, T., Little, B., Krejci, D., Reissner, A., and Seifert, B. "Development, Production, and Testing of the IFM Nano FEEP Thruster." 36<sup>th</sup> IEPC, Vienna, Austria, IEPC-2019-362, 2019.
- (264) Krejci, D., Hugonnaud, V., Schonherr, T., Little, B., Reissner, A., Seifert, B., Kock, Q, Borrás, E., and Amo, J. "Full Performance Mapping of the IFM Nano Thruster, Including Direct Thrust Measurements." *Journal of Small Satellites*, 2019, Vol. 8, No. 2, pp. 881-893.
- (265) Enpulsion, "Enpulsion Nano R3." Company Website, Datasheet ENP2019-086.E.1, Accessed 2022.
- (266) Enpulsion, "Enpulsion Micro R<sup>3</sup>." Company Website, Datasheet ENP2018-002.H.1, Accessed 2021.
- (267) Grimaud, L., Krejci, D., and Seifert, B. "The IFM Micro FEEP Thruster: A Modular Design for SmallSat Propulsion." 36<sup>th</sup> IEPC, Vienna, Austria, IEPC-2019-A675, 2019.
- (268) Morpheus Space, "nanoFEEP and multiFEEP." Company Website, Datasheet, June, 2020. URL: <https://www.morpheus-space.com/static/MSWeb/documents/M-Space%20Products.pdf>.
- (269) Bock, D., Spethmann, A., Trottenberg, T., Kersten, H., and Tajmar, M. "In-Plume Thrust Measurement of NanoFEEP Thruster with a Force Measuring Probe Using Laser Interferometry." 36<sup>th</sup> IEPC, Vienna, Austria, IEPC-2017-391, 2017.
- (270) Accion Systems, "TILE-2-4C." Company Website, Datasheet, Copyright 2019.
- (271) Accion Systems, "TILE-3-36C-1U." Company Website, Datasheet, Copyright 2019.
- (272) Avant Space, "GT-50 RF Ion Thruster." Company Datasheet. URL: <http://www.avantspace.com/upload/iblock/dc9/Data-sheet.pdf>
- (273) Kralkin, E., et al. "Exploratory Testing of a Radio-Frequency Thruster for Small Satellites." IEPC-2017-425.
- (274) Busek, "BIT-3 RF Ion Thruster." Company Website, Datasheet, Copyright 2019.



- (275) "All-Electric CubeSat Propulsion Technologies for Versatile Mission Application." 32nd International Symposium on Space Technology and Science (ISTS), Fukui, Japan, June, 2019, ISTS-2019-b-002.
- (276) Tsay, M., Frongillo, J., Model, J., Zwahlen, J., Barcroft, C., Feng, C. "Neutralization Demo and Thrust Stand Measurement for BIT-3 RF Ion Thruster." 2017 AIAA Propulsion and Energy Forum, Atlanta, GA, July, 2017, AIAA-2017-4890.
- (277) Tsay, M., "3,500-Hour Wear Test Result of BIT-3 RF Ion Propulsion System", IEPC-2022-255, 37th International Electric Propulsion Conference, Cambridge, MA, 19-23 June 2022.
- (278) Tsay, M., et al., "Volume Production of Gen-2 Iodine BIT-3 Ion Propulsion System", IEPC-2022-267, 37th International Electric Propulsion Conference, Cambridge, MA, 19-23 June 2022.
- (279) Pale Blue, "Products – Ion Thruster," Website Datasheet, Accessed October 2022.
- (280) Nakagawa, Y., Yaginuma, K., Asakawa, J., and Koizumi, H., "1U+Water Ion and Resistojet Thruster Module for On-Orbit Demonstration," IEPC-2022-276, 37th International Electric Propulsion Conference, Cambridge, MA, 19-23 June 2022.
- (281) Navin, J., "JAXA Epsilon fails on sixth flight carrying RAISE-3 and others," NASA Spaceflight.com, 11 October 2022
- (282) ThrustMe, "NPT30-Xe." Company Website, Datasheet, Copyright 2019.
- (283) ThrustMe, "NPT30-I2 1.5U," Company Website, Datasheet, Copyright 2020.
- (284) Martinez, J., Rafalskyi, D., and Aanesland, A. "Development and Testing of the NPT30-I2 Iodine Ion Thruster." 36<sup>th</sup> IEPC, Vienna, Austria, IEPC-2019-811, 2019.
- (285) ThrustMe, "NPT30-I2 1U," Company Website, Datasheet, Copyright 2021.
- (286) Leiter, H., Lauer, D., Bauer, P., Berger, M., and Rath, M. "The Ariane Group Electric Propulsion Program 2019-2020." 36<sup>th</sup> IEPC, Vienna, Austria, IEPC-2019-592, 2019.
- (287) Leiter, H., Altmann, C., Lauer, D., Rath, M., Becker, F., Feili, D., and Amo, J. "A Nouvelle Neutralization Concept for RIT- $\mu$ X Miniaturized Radio Frequency Ion Thruster Systems." 36<sup>th</sup> IEPC, Vienna, Austria, IEPC-2019-806, 2019.
- (288) Ariane Group, "Electric Propulsion Systems and Components." Company Website, Datasheet, Accessed 2020.
- (289) Leiter, H., Lotz, B., Feili, D., Tartz, M., Neumann, H., and Cara, D. "Design Development and Test of the RIT- $\mu$ X Mini Ion Engine System." IEPC-2009-179.
- (290) Leiter, H., et al., "Recent Development of the RIT- $\mu$ X Thruster and System", IEPC-2022-252, 37th International Electric Propulsion Conference, Cambridge, MA, 19-23 June 2022.
- (291) Holste, K., et al., "Endurance and Coupling Test of the RIT- $\mu$ X", IEPC-2022-247, 37th International Electric Propulsion Conference, Cambridge, MA, 19-23 June 2022.
- (292) Leiter, H., Altmann, C., Porst, J., Lauer, D., Berger, M., and Rath, M. "Six Decades of thrust – The Ariane Group Radiofrequency Ion Thrusters and Systems Family." IEPC-2017-027.
- (293) C.H. Edwards et al., "The T5 Ion Propulsion Assembly for Drag Compensation on GOCE", 2nd International GOCE User Workshop, ESA-ESRIN Frascati Italy, 8-10 March 2004.
- (294) P.N. Randall et al., "T5 Performance, Industrialization and Future Applications", IEPC-2019-688.
- (295) Szabo, J., Tedrake, R., Metivier, E., Paintal, S., and Taillefer, Z. "Characterization of a One Hundred Watt, Long Lifetime Hall Effect Thruster for Small Spacecraft." 53<sup>rd</sup> AIAA Joint Propulsion Conference, Atlanta, Georgia, 2017.
- (296) Busek, "BHT-200 Busek Hall Effect Thruster." Company Website, Datasheet, 2019.
- (297) Hruby, V., Monheiser, J., Pote, B., Freeman, C., and Connolly, W. "Low Power, Hall Thruster Propulsion System." IEPC-99-092, Kitakyushu, Japan, 1999.

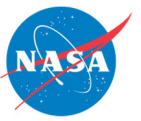




- (298) Busek, "BHT-600 Busek Hall Effect Thruster." Company Website, Datasheet, 2016.
- (299) Szabo, J., Pote, B., Tedrake, R., Paintal, S., Byrne, L., Hruby, V., Kamhawi, H., and Smith, T. "High Throughput 600 Watt Hall Effect Thruster for Space Exploration." 52<sup>nd</sup> AIAA Joint Propulsion Conference, Salt Lake City, Utah, 2016.
- (300) Benavides, G., Kamhawi, H., Mackey, J., Haag, T., and Costa, G., "Iodine Hall-Effect Electric Propulsion System Research, Development, and System Durability Demonstration," 2018 Joint Propulsion Conference, Cincinnati, Ohio, July 9-11, 2018.
- (301) Saevets, P., Semenenko, D., Albertoni, R., and Scremin, G. "Development of a Long-Life Low-Power Hall Thruster." 35<sup>th</sup> IEPC, Atlanta, Georgia, 2017.
- (302) Conversano, R., Goebel, D., Katz, I., and Hofer, R. "Low-Power Hall Thruster with an Internally Mounted Low-Current Hollow Cathode." U.S. Patent No. 10,723,489, 2020.
- (303) Conversano, R., Reilly, S., Kerber, T., Brooks, J., and Goebel, D. "Development of and Acceptance Test Preparations for the Thruster Component of the Ascendant Sub-kW Transcelestial Electric Propulsion System (ASTRAEUS)." 36<sup>th</sup> IEPC, Vienna, Austria, 2019.
- (304) Conversano, R., Lobbia, R., Kerber, T., Tilley, K., Goebel, D., and Reilly, S. "Performance characterization of a low-power magnetically shielded Hall thruster with an internally-mounted hollow cathode." Plasma Sources Science and Technology, Vol. 28, No. 10, 2019.
- (305) Conversano, R., Barchowsky, A., Lobbia, R., Chaplin, V., Lopez-Ortega, A., Loveland, J., Lui, A., Becatti, G., Reilly, S., Goebel, D., Snyder, J., Hofer, R., Randolph, T., Mikellides, I., Vorperian, V., Carr, G., Rapinchuk, J., Villalpando, C., and Grebow, D. "Overview of the Ascendant Sub-kW Transcelestial Electric Propulsion System (ASTRAEUS)." 36<sup>th</sup> IEPC, Vienna, Austria, 2019.
- (306) Lobbia, R., Conversano, R., Ortega, A., Reilly, S., Mikellides, I. "Pole Erosion Measurements for the Development Model of the Magnetically Shielded Miniature Hall Thruster (MaSMi-DM)." 36<sup>th</sup> IEPC, Vienna, Austria, 2019.
- (307) Ortega, A., Mikellides, I., Conversano, R., Lobbia, R., Chaplin, V. "Plasma Simulations for the Assessment of Pole Erosion in the Magnetically Shielded Miniature Hall Thruster (MaSMi)." 36<sup>th</sup> IEPC, Vienna, Austria, 2019.
- (308) JPL Press Release, "2020 Technology Highlights, Jet Propulsion Laboratory," CL#20-6401.
- (309) Conversano, R., Barchowsky, A., Vorperian, V., Chaplin, V., Becatti, G., Carr, G., Stell, C., Loveland, J., and Goebel, D., "Cathode & Electromagnet Qualification Status and Power Processing Unit Development Update for the Ascendant Sub-kW Transcelestial Electric Propulsion System," 34<sup>th</sup> Small Satellite Conference, 2020, SSC20-VI-10.
- (310) Conversano, R., Lobbia, R., Lopez-Ortega, A., Chaplin, V., Reilly, S., Arestie, S., Goebel, D., "Long-Duration Wear Testing of the ASTRAEUS Hall Thruster, Phase 1: 50 kg Xe Total Throughput," Space Propulsion 2020+1, 17-19 March 2021, SP2020-005.
- (311) Conversano, R. W., Lobbia, R. B., Arestie, S. M., Lopez-Ortega, A., Chaplin, V. H., Reilly, S. W., and Goebel, D. M.; "Demonstration of 100 kg Xenon Propellant Throughput by a Low-Power Magnetically Shielded Hall Thruster," Journal of Propulsion and Power, 2022.
- (312) Conversano, R. W., Becatti, G., Goebel, D. M., and Chaplin, V. H.; "Demonstration of 13,011-hours of Operation of a Proto-Flight Compact Heaterless Lanthanum Hexaboride Hollow Cathode," Acta Astronautica, Vol. 197, 2022, pp. 53-59. DOI: <https://doi.org/10.1016/j.actaastro.2022.05.015>.
- (313) Becatti, G., Conversano, R. W, and Goebel, D. M., "Demonstration of 25,000 ignitions on a proto-flight compact heaterless lanthanum hexaboride hollow cathode," Acta Astronautica, Vol. 178, 2021, pp. 181-191, DOI: <https://doi.org/10.1016/j.actaastro.2020.09.013>.



- (314) Sommerville, J., Frunceck, C., King, L., Makela, J., Terhune, K., Washeleski, R., and Myers, R. "Performance of the Aurora Low-Power Hall-Effect Thruster." 36<sup>th</sup> IEPC, Vienna, Austria, 2019.
- (315) Safran, "PPS-X00 Stationary Plasma Thruster," Company Datasheet, Dated 11/09/19.
- (316) Vaudolon, J., Vial, V., Cornu, N., and Habbassi, I. "PPS-X00 Thruster Development Status at Safran." 36<sup>th</sup> IEPC, Vienna, Austria, 2019.
- (317) SITAEL "Electric Propulsion – HT400 Hall Effect Thruster Product Sheet." Company Website, Datasheet, 2020.
- (318) Ducci, C., Raiji, H., Pedrini, D., Misuri, T., and Onida, L. "SITAEL's HT400 Hall Effect Thruster for Constellation Applications." 36<sup>th</sup> IEPC, Vienna, Austria, 2019.
- (319) Pedrini, D., Ducci, C., Misuri, T., Paganucci, F., Andrenucci, M. "Sitael Hollow Cathodes for Low-Power Hall Effect Thrusters." IEEE Transactions on Plasma Science, Vol. 46, No. 2, February, 2018.
- (320) Space Electric Thruster Systems "ST25 Hall-Effect Thruster." Company Website, Datasheet, 2020.
- (321) Petrenko, O., Tolok, S., Maslov, V., Kulagin, S., Serbin, V., Alekseenko, O., and Shcherbak, D. "Electric propulsion system SPS-25 with Hall Thruster." 70<sup>th</sup> International Astronautical Congress (IAC), Washington D.C., October, 2019.
- (322) Space Electric Thruster Systems "ST40 Hall-Effect Thruster." Company Website, Datasheet, 2020.
- (323) Krishnan, M., Velas, K., and Leemans, S. "Metal Plasma Thruster for Small Satellites." Journal of Propulsion and Power, March, 2020, DOI: 10.2514/1.B37603.
- (324) Busek "BmP-220 Technical Specifications." Company Website, Datasheet, Copyright 2019.
- (325) Jarrige, J., Packan, D., Blanchet, A., and Herrero, L. "Direct Thrust Measurement of a Vacuum Arc Thruster." 36<sup>th</sup> IEPC, Vienna, Austria, 2019.
- (326) Blanchet, A., Herrero, L., Voisin, L., Pilloy, B., and Courteville, D. "Plasma Jet Pack Technology for Nano-Microsatellites." 36<sup>th</sup> IEPC, Vienna, Austria, 2019.
- (327) Ciaralli et al. "Results of the Qualification Test Campaign of a Pulsed Plasma Thruster for CubeSat Propulsion (PPTCUP)." Acta Astronautica, Volume 121, Pages 314-322, April–May, 2016.
- (328) Siddiqui, M., Cretel, C., Synowiec, J., Hsu, A., Young, J., and Spektor, R. "First Performance Measurements of the Phase Four RF Thruster." 35<sup>th</sup> IEPC, Atlanta, GA, October, 2017.
- (329) Siddiqui, M. and Cretel, C. "Updated Performance Measurements and Analysis of the Phase Four RF Thruster." Joint Propulsion Conference, Cincinnati, OH, AIAA-2018-4817.
- (330) Cretel, C., Ajamia, M., Thompson, D., and Siddiqui, M. "Torsional Balance Thrust Measurement Techniques for Small RF Thrusters."
- (331) "Meet Maxwell." Phase Four, website, accessed 2020, URL: <https://www.phasefour.io/maxwell/>
- (332) Phase Four, "Maxwell Product Suite," Website Datasheet, Accessed October 2022
- (333) "REGULUS Electrical Propulsion System for Micro-satellites." T4i, datasheet. URL: [https://www.t4innovation.com/wp-content/uploads/2019/10/T4i\\_REGULUS\\_datasheet\\_.pdf](https://www.t4innovation.com/wp-content/uploads/2019/10/T4i_REGULUS_datasheet_.pdf)
- (334) "M1.4 Thruster Interface and User Manual", version 1.4, <https://miles-space.com/thruster/>
- (335) "Terminator Tape." Tethers Unlimited, datasheet, 2020. URL: <https://www.tethers.com/wp-content/uploads/2020/03/2020-Terminator-Tape.pdf>



## Chapter Contents

Chapter Glossary .....	ii
5.0 Guidance, Navigation & Control .....	128
5.1 Introduction .....	128
5.2 State-of-the-Art – GNC Subsystems .....	129
5.2.1 Integrated Units .....	129
5.2.2 Reaction Wheels .....	132
5.2.3 Magnetic Torquers.....	134
5.2.4 Thrusters .....	136
5.2.5 Star Trackers .....	136
5.2.6 Magnetometers.....	139
5.2.7 Sun Sensors .....	140
5.2.8 Horizon Sensors .....	144
5.2.9 Inertial Sensing.....	145
5.2.10 GPS Receivers .....	150
5.2.11 Deep Space Navigation.....	151
5.2.12 Atomic Clocks.....	151
5.2.13 LiDAR .....	152
5.3 On the Horizon.....	153
5.4 Summary.....	154
References.....	154



## Chapter Glossary

(ADCS)	Attitude Determination and Control System
(CoCom)	Coordinating Committee for Multilateral Export Controls
(COTS)	Commercial-off-the-Shelf
(DOF)	Degrees of Freedom
(DSAC)	Deep Space Atomic Clock
(DSN)	Deep Space Network
(EAR)	Export Administration Regulations
(FOGs)	Fiber Optic Gyros
(GNC)	Guidance, Navigation & Control
(GSO)	Geo-stationary Orbit
(USAF)	U.S. Air Force
(HCI)	Horizon Crossing Indicators
(IMUs)	Inertial Measurement Units
(JPL)	Jet Propulsion Laboratory
(Lidar)	Light Detection and Ranging
(LMRST)	Low Mass Radio Science Transponder
(MarCO)	Mars Cube One
(PMSM)	Permanent-magnet Synchronous Motor
(SDST)	Small Deep Space Transponder
(SWaP)	Size, weight, and power
(TLE)	Two-Line Element
(TRL)	Technology Readiness Level



## 5.0 Guidance, Navigation & Control

### 5.1 Introduction

The Guidance, Navigation & Control (GNC) subsystem includes the components used for position determination and the components used by the Attitude Determination and Control System (ADCS). In Earth orbit, onboard position determination can be provided by a Global Positioning System (GPS) receiver. Alternatively, ground-based radar tracking systems can also be used. If onboard knowledge is required, then these radar observations can be uploaded and paired with a suitable propagator. Commonly, the U.S. Air Force (USAF) publishes Two-Line Element sets (TLE) (1), which are paired with a SGP4 propagator (2). In deep space, position determination is performed using the Deep Space Network (DSN) and an onboard radio transponder (3). There are also technologies being developed that use optical detection of celestial bodies such as planets and X-ray pulsars to calculate position data (23).

Using SmallSats in cislunar space and beyond requires a slightly different approach than the GNC subsystem approach in low-Earth orbit. Use of the Earth's magnetic field, for example, is not possible in these missions, and alternate ADCS designs and methods must be carefully considered. Two communication relay CubeSats (Mars Cube One, MarCO) successfully demonstrated such interplanetary capability during the 2018 Insight mission to Mars (4). This interplanetary mission demonstrated both the capability of this class of spacecraft and the GNC fine pointing design for communication in deep space.

ADCS includes sensors to determine attitude and spin rate, such as star trackers, sun sensors, horizon sensors, magnetometers, and gyros. In addition, the ADCS is often used to control the vehicle during trajectory correction maneuvers and, using accelerometers, to terminate maneuvers when the desired velocity change has been achieved. Actuators are designed to change a spacecraft's attitude and to impart velocity change during trajectory correction maneuvers. Common spacecraft actuators include magnetic torquers, reaction wheels, and thrusters. There are many attitude determination and control architectures and algorithms suitable for use in small spacecraft (5).

Miniaturization of existing technologies is a continuing trend in small spacecraft GNC. While three-axis stabilized, GPS-equipped, 100 kg class spacecraft have been flown for decades, it has only been in the past few years that such technologies have become available for micro- and nano-class spacecraft. Table 5-1 summarizes the current state-of-the-art of performance for GNC subsystems in small spacecraft. Performance greatly depends on the size of the spacecraft and values will range for nano- to micro-class spacecraft.

The information described below is not intended to be exhaustive but provides an overview of current state-of-the-art technologies and their development status for a particular small spacecraft subsystem. It should be noted that Technology Readiness Level (TRL) designations may vary with changes specific to payload, mission requirements, reliability considerations, and/or the environment in which performance was demonstrated. Readers are highly encouraged to reach out to companies for further information regarding the performance and TRL of described technology. There is no intention of mentioning certain companies and omitting others based on their technologies or relationship with NASA.

Table 5-1: State-of-the-Art GNC Subsystems		
Component	Performance	TRL
Reaction Wheels	0.00023 – 0.3 Nm peak torque, 0.0005 – 8 N m s storage	7-9
Magnetic Torquers	0.15 A m <sup>2</sup> – 15 A m <sup>2</sup>	7-9
Star Trackers	8 arcsec pointing knowledge	7-9
Sun Sensors	0.1° accuracy	7-9
Earth Sensors	0.25° accuracy	7-9
Inertial Sensors	Gyros: 0.15° h <sup>-1</sup> bias stability, 0.02° h <sup>-1/2</sup> ARW Accels: 3 μg bias stability, 0.02 (m s <sup>-1</sup> )/h <sup>-1/2</sup> VRW	7-9
GPS Receivers	1.5 m position accuracy	7-9
Integrated Units	0.002-5° pointing capability	7-9
Atomic Clocks	10 – 150 Frequency Range (MHz)	5-6
Deep Space Navigation	Bands: X, Ka, S, and UHF	7-9
Altimeters	~15 meters altitude, ~3 cm accuracy	7

## 5.2 State-of-the-Art – GNC Subsystems

### 5.2.1 Integrated Units

Integrated units combine multiple different attitude and navigation components to provide a simple, single-component solution to a spacecraft's GNC requirements. Typical components included are reaction wheels, magnetometer, magnetic torquers, and star trackers. The systems often include processors and software with attitude determination and control capabilities. Table 5-2 describes some of the integrated systems currently available. Blue Canyon Technologies' XACT (figure 5.1) flew on the NASA-led missions MarCO and ASTERIA, both of which were 6U platforms, and have also flown on 3U missions (MinXSS was deployed from NanoRacks in February 2016).

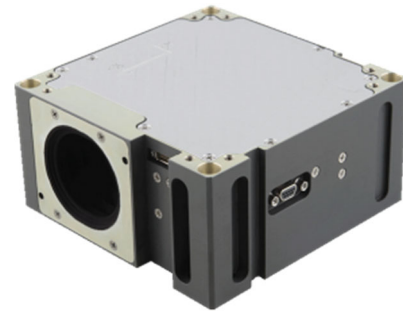


Figure 5.1: BCT XACT Integrated ADCS Unit. Credit: Blue Canyon Technologies.

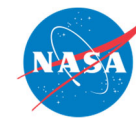


Table 5-2: Currently Available Integrated Systems

Manufacturer	Model	Mass (kg)	Actuators	Sensors	Processor	Pointing Accuracy	T R L
Arcsec	Arcus ADC	0.715	3 reaction wheels 3 magnetic torquers	1 star tracker 3 gyros 6 photodiodes 3 magnetometers	Yes	0.1°	7-9
Berlin Space Technologies	IADCS-100	0.4	3 reaction wheels 3 magnetic torquers	1 star tracker 3 gyros, 1 magnetometer, 1 accelerometer	Yes	<<1 deg	7
AAC Clyde Space	iADCS-200	0.470	3 reaction wheels 3 magnetic torquers	1 star tracker 1 IMU, Optionally high precision magnetometer and sun sensors	Yes	<1°	7-9
AAC Clyde Space	iADCS-400	1.7	3 reaction wheels 3 magnetorquers	1 star tracker, 1 IMU, Optionally high precision magnetometer and sun sensors	Yes	<1°	7-9
Blue Canyon Technologies	XACT-15	0.885	3 reaction wheels 3 magnetorquers	1 star tracker 3-axis magnetometer	Yes	0.003/0.007°	7-9
Blue Canyon Technologies	XACT-50	1.230	3 reaction wheels 3 magnetorquers	1 star tracker 3-axis magnetometer	Yes	0.003/0.007°	7-9
Blue Canyon Technologies	XACT-100	1.813	3 reaction wheels 3 magnetorquers	1 star tracker 3-axis magnetometer	Yes	0.003/0.007°	7-9



Blue Canyon Technologies	Flexcore	configuration dependent	3 – 4 reaction wheels 3 magnetorquers	2 star trackers 3-axis magnetometer	Yes	0.002°	7-9
CubeSpace Satellite Systems	CubeADCS 3-Axis Small	0.55	3 reaction wheels 3 magnetorquers	10 coarse sun sensors 2 fine sun/earth sensors 1 magnetometer	Yes	<1°	7-9
CubeSpace Satellite Systems	CubeADCS 3-Axis Small with Star Tracker	0.61	3 reaction wheels 3 magnetorquers	10 coarse sun sensors 2 fine sun/earth sensors 1 magnetometer 1 star tracker	Yes	<0.1°	7-9
CubeSpace Satellite Systems	CubeADCS 3-Axis Medium	0.79	3 reaction wheels 3 magnetorquers	10 coarse sun sensors 2 fine sun/earth sensors 1 magnetometer	Yes	<1°	7-9
CubeSpace Satellite Systems	CubeADCS 3-Axis Medium with Star Tracker	0.84	3 reaction wheels 3 magnetorquers	10 coarse sun sensors 2 fine sun/earth sensors 1 magnetometer 1 star tracker	Yes	<0.1°	7-9
CubeSpace Satellite Systems	CubeADCS 3-Axis Large	1.1	3 reaction wheels 3 magnetorquers	10 coarse sun sensors 2 fine sun/earth sensors 1 magnetometer	Yes	<1°	7-9
CubeSpace Satellite Systems	CubeADCS 3-Axis Large with Star Tracker	1.15	3 reaction wheels 3 magnetorquers	10 coarse sun sensors 2 fine sun/earth sensors 1 magnetometer 1 star tracker	Yes	<0.1°	7-9
CubeSpace Satellite Systems	CubeADCS Y-Momentum	0.3	1 momentum wheel 3 magnetic torquers	10 coarse sun sensors 1 magnetometer	Yes	<5°	7-9





### 5.2.2 Reaction Wheels

Miniaturized reaction wheels provide small spacecraft with a three-axis precision pointing capability. They must be carefully selected based on several factors including the mass of the spacecraft and the required rotation performance rates. Reaction wheels provide torque and momentum storage along the wheel spin axis which results in the spacecraft counter-rotating around the spacecraft center of mass due to conservation of angular momentum from the wheel spin direction. Table 5-3 lists a selection of high-heritage miniature reaction wheels. Except for three units, all the reaction wheels listed have spaceflight heritage. For full three-axis control, a spacecraft requires three wheels mounted orthogonally. However, a four-wheel configuration is often used to provide fault tolerance (6). Reaction wheels need to be periodically desaturated using an actuator that provides an external torque, such as thrusters or magnetic torquers (7).

In addition, the multiple reaction wheels are often assembled in a “skewed” or angled configuration such that there exists a cross-coupling of torques with two or more reaction wheels. While this reduces the torque performance in any single axis, it allows a redundant, albeit reduced, torque capability in more than one axis. The result is that should any single reaction wheel fail, one or more reaction wheels are available as a reduced-capability backup option.

Table 5-3: High Heritage Miniature Reaction Wheels								
Manufacturer	Model	Mass (kg)	Peak Power (W)	Peak Torque (Nm)	Momentum Capacity (Nms)	# Wheels	Radiation Tolerance (krad)	T R L
Berlin Space Technologies	RWA05	1.700	0.5	0.016	0.0005	1	30	7-9
Blue Canyon Technologies	RWP015	0.130	1	0.004	0.015	1	Unk	7-9
Blue Canyon Technologies	RWP050	0.240	1	0.007	0.050	1	Unk	7-9
Blue Canyon Technologies	RWP100	0.330	1	0.007	0.100	1	Unk	7-9
Blue Canyon Technologies	RWP500	0.750	6	0.025	0.500	1	Unk	7-9
Blue Canyon Technologies	RW1	0.950	10	0.07	1.000	1	Unk	7-9
Blue Canyon Technologies	RW4	3.200	10	0.250	4.000	1	Unk	7-9
Blue Canyon Technologies	RW8	4.400	10	0.250	8.000	1	Unk	7-9
CubeSpace Satellite Systems	CubeWheel Small	0.060	0.65	0.00023	0.00177	1	24	7-9
CubeSpace Satellite Systems	CubeWheel Small+	0.090	2.3	0.0023	0.0036	1	24	7-9
CubeSpace Satellite Systems	CubeWheel	0.150	2.3	0.001	0.01082	1	24	7-9



	Medium							
CubeSpace Satellite Systems	CubeWheel Large	0.225	4.5	0.0023	0.03061	1	24	7-9
GomSpace	NanoTorque GSW-600	0.940	0.3	0.0015	0.019	1	Unk	Unk
Comat	RW20	0.180	1	0.002	0.02	1	Up to 20Krad*	7
Comat	RW40	0.230	1	0.004	0.04	1	Up to 20Krad*	8
Comat	RW60	0.275	1	0.006	0.06	1	Up to 20Krad*	7
AAC Clyde Space	RW210	0.48	0.8	0.0001	0.006	1	36	7-9
AAC Clyde Space	RW400	0.375	15	0.008	0.050	1	36	7-9
AAC Clyde Space	Trillian-1	1.5	24	47.1	1.2	1	Unk	
NanoAvionics	RWO	0.137	3.25	0.0032	0.020	1	20	7-9
NanoAvionics	4RWO	0.665	6	0.0059	0.037	4	20	7-9
NewSpace Systems	NRWA-T6	<5	136	0.3	0.00783	1	20	7-9
NewSpace Systems	NRWA-T065	1.55	1.7	0.02	0.00094	1	10	7-9
NewSpace Systems	NRWA-T2	2.8	0.4	0.09	0.00163	1	10	7-9
Rocket Lab	RW-0.03	0.185	1.8	0.002	0.040	1	20	7-9
Rocket Lab	RW-0.003	0.048	Unk	0.001	0.005	1	10	5-6
Rocket Lab	RW-0.01	0.122	1.05	0.001	0.018	1	20	7-9
Rocket Lab	RW3-0.06	0.235	23.4	0.020	0.180	1	20	7-9
Rocket Lab	RW4-0.2	0.6	Unk	0.1	0.2	1	60	7-9
Rocket Lab	RW4-0.4	0.77	Unk	0.1	0.4	1	60	7-9
Rocket Lab	RW4-1.0	1.38	43	0.1	1	1	60	7-9

Vectronic Aerospace	VRW-A-1	1.90	110	0.090	6.000	1	20	U n k
Vectronic Aerospace	VRW-B-2	1.00	45	0.020	0.200	1	20	U n k
Vectronic Aerospace	VRW-C-1	2.3	45	0.020	1.20	1	20	U n k
Vectronic Aerospace	VRW-D-2	2	65	0.05	2.0	1	20	U n k
Vectronic Aerospace	VRW-D-6	3	110	0.09	6	1	20	U n k

\*Printed Circuit Board (PCB) level

### 5.2.3 Magnetic Torquers

Magnetic torquers provide control torques perpendicular to the local external magnetic field. Table 5-4 lists a selection of high heritage magnetic torquers and figure 5.3 illustrates some of ZARM Technik's product offerings. Magnetic torquers are often used to remove excess momentum from reaction wheels. As control torques can only be provided in the plane perpendicular to the local magnetic field, magnetic torquers alone cannot provide three-axis stabilization.



Figure 5.3: Magnetorquers for microsatellites. Credit: ZARM Technik.

Use of magnetic torquers beyond low-Earth orbit and in interplanetary applications need to be carefully investigated since their successful operation is relying on a significant local external magnetic field. This magnetic field may or may not be available in the location and environment for that mission and additional control methods may be required.

Manufacturer	Model	Mass (kg)	Power (W)	Peak Dipole (A m <sup>2</sup> )	# Axes	Radiation Tolerance (krad)	TRL
CubeSpace Satellite Systems	CubeTorquer Small	0.028	0.42	0.24	1	24	7-9
CubeSpace Satellite Systems	CubeTorquer Medium	0.036	0.37	0.66	1	24	7-9



CubeSpace Satellite Systems	CubeTorquer Large	0.072	0.37	1.90	1	24	7-9
CubeSpace Satellite Systemse	CubeTorquer Coil(Single)	0.046	0.31	0.13	1	24	7-9
CubeSpace Satellite Systems	CubeTorquer Coil(Double)	0.074	0.64	0.27	1	24	7-9
GomSpace	Nano Torque GST-600	0.156	Unk	0.31 – 0.34	3	Unk	Unk
GomSpace	NanoTorque Z-axis Internal	0.106	Unk	0.139	1	Unk	Unk
ISISPACE	Magnetorque r Board	0.196	1.2	0.20	3	Unk	7-9
MEISEI	Magnetic Torque Actuator for Spacecraft	0.5	1	12	1	Unk	7-9
AAC Clyde Spce	MTQ800	0.395	3	15	1	Unk	7-9
NanoAvionics	MTQ3X	0.205	0.4	0.30	3	20	7-9
NewSpace Systems	NCTR-M003	0.030	0.25	0.29	1	Unk	7-9
NewSpace Systems	NCTR-M012	0.053	0.8	1.19	1	Unk	7-9
NewSpace Systems	NCTR-M016	0.053	1.2	1.6	1	Unk	7-9
Rocket Lab	TQ-40	0.825	Unk	48.00	1	Unk	7-9
Rocket Lab	TQ-15	0.400	Unk	19.00	1	Unk	7-9
ZARM Technik**	MT0.2-1	0.012-0.014	0.135-0.25	0.2	1	NA*	7-9
ZARM Technik	MT0.5-1	0.009	0.275	0.5	1	NA*	7-9
ZARM Technik	MT0.7-1-01	0.035	0.5	0.7	1	NA*	7-9
ZARM Technik	MT1-1-01	0.065	0.23	1	1	NA*	7-9
ZARM Technik	MT1.5-1-01	0.097	0.4	1.5	1	NA*	7-9
ZARM Technik	MT2-1-02	0.1	0.5	2	1	NA*	7-9
ZARM Technik	MT3-1-D22042701	0.15	0.7	3	1	NA*	7-9



ZARM Technik	MT4-1	0.15	0.6	4	1	NA*	7-9
ZARM Technik	MT5-1	0.19-0.3	0.73-0.75	5	1	NA*	7-9
ZARM Technik	MT5-2	0.31	0.77	5	1	NA*	7-9
ZARM Technik	MT6-2	0.25-0.3	0.48-1.1	6	1	NA*	7-9
ZARM Technik	MT7-2	0.4	0.9	7	1	NA*	7-9
ZARM Technik	MT10-1	0.35-0.4	0.53-0.8	10	1	NA*	7-9
ZARM Technik	MT10-2	0.37-0.48	0.7-1	10	1	NA*	7-9
ZARM Technik	MT15-1	0.4-0.55	1.0-1.55	15	1	NA*	7-9
ZARM Technik	MT15-2	0.5-0.55	0.9-1.5	15	1	NA*	7-9

\* Only EEE parts are connector and wires. Magnetotorquer is not sensitive to ionizing radiation.

\*\* ZARM Technik: Over 200 models available with design to mass/power optimization

#### 5.2.4 Thrusters

Thrusters used for attitude control are described in Chapter 4: In-Space Propulsion. Pointing accuracy is determined by minimum impulse bit, and control authority by thruster force.

#### 5.2.5 Star Trackers

A star tracker can provide an accurate estimate of the absolute three-axis attitude by comparing a digital image to an onboard star catalog (8). Star trackers identify and track multiple stars and provide three-axis attitude several times a second. Table 5-5 lists some models suitable for use on small spacecraft. For example, Arcsec's Sagitta Star Tracker was launched on the SIMBA cubesat in 2020.

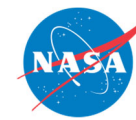
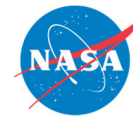


Table 5-5: Star Trackers Suitable for Small Spacecraft

Manufacturer	Model	Mass (kg)	Power (W)	FOV	Cross axis accuracy (3s)	Twist accuracy (3s)	Radiation Tolerance (krad)	TRL
Redwire Space	Star Tracker	0.475	2.5	14x19	10/27"	51"	75	7-9
Arcsec	Sagitta	0.275	1.4	25.4°	6	30	20	7-9
Arcsec	Twinkle	0.04	0.6	10.4°	30	180	Unk	7-9
Ball Aerospace	CT-2020	3.000	8	Unk	1.5"	1"	Unk	5-6
Berlin Space Technologies / AAC Clyde Space	ST200	0.040	0.65	22°	30"	200"	11	7-9
Berlin Space Technologies / AAC Clyde Space	ST400	0.250	0.75	15°	15"	150"	11	7-9
Blue Canyon Technologies	Standard NST	0.350	1.5	10° x 12°	6"	40"	Unk	7-9
Blue Canyon Technologies	Extended NST	1.300	1.5	10° x 12°	6"	40"	Unk	7-9
Creare	UST	0.840	Unk	Unk	7"	15"	Unk	5-6
CubeSpace Satellite Systems	CubeStar	0.055	0.264	58-47°	55.44" 0.02°	77.4	19	7-9
Danish Technical University	MicroASC	0.425	1.9	Unk	2"	Unk	Unk	7-9
Leonardo	Spacestar	1.600	6	20° x 20°	7.7"	10.6"	Unk	7-9
NanoAvionics	ST-1	0.108	1.2	21° full-cone	8"	50"	20	7-9
Rocket Lab	ST-16RT2	0.185	1	8° half-cone	5"	55"	Unk	7-9
Sodern	Auriga-CP	0.205	1.1	Unk	2"	11"	Unk	7-9



Sodern	Hydra-M	2.75	7	Unk	Unk	Unk	Unk	5-6
Sodern	Hydra-TC	5.3	8	Unk	Unk	Unk	Unk	5-6
Solar MEMS Technologies	STNS	0.14	1	12°	40"	70"	20	7-9
Space Micro	MIST	0.520	3	14.5°	15"	105"	30	7-9
Space Micro	μSTAR-100M	1.800	5	Unk	15"	105"	100	Unk
Space Micro	μSTAR-200M	2.100	8-10	Unk	15"	105"	100	Unk
Space Micro	μSTAR-200H	2.700	10	Unk	3"	21"	100	Unk
Space Micro	μSTAR-400M	3.300	18	Unk	15"	105"	100	Unk
Terma	T1	0.76	0.8	20° circular	2.2"	9"	100	5-6
Terma	T3	0.35	2	20° circular	2.6"	10"	8	5-6
Vectronic Aerospace	VST-41MN	0.7 - 0.9	2.5	14° x 14°	27"	183"	20	7-9
Vectronic Aerospace	VST-68M	0.470	3	14° x 14°	7.5"	45"	20	Unk



### 5.2.6 Magnetometers

Magnetometers provide a measurement of the local magnetic field which can be used to estimate 2-axis information about the attitude (9). Table 5-6 provides a summary of some three-axis magnetometers available for small spacecraft, one of which is illustrated in figure 5.4.



Figure 5.4: NSS Magnetometer. Credit: NewSpace Systems.

Table 5-6: Three-axis Magnetometers for Small Spacecraft							
Manufacturer	Model	Mass (kg)	Power (W)	Resolution (nT)	Orthogonality	Radiation Tolerance (krad)	T R L
GomSpace	NanoSense M315	0.008	Unk	Unk	Unk	Unk	7-9
AAC Clyde Space	MM200	0.012	0.01	1.18	Unk	30	7-9
MEISEI	3-Axis Magnetometer for Small Satellite	0.220	1.5	Unk	1°	Unk	7-9
NewSpace Systems	NMRM-Bn25o485	0.085	0.75	8	1°	10	7-9
AAC Clyde Space	MAG-3	0.100	Voltage Dependent	Unk	1°	10	7-9
ZARM Technik	Analogue High-Rel Fluxgate Magnetometer FGM-A-75	0.33	0.75 W	±75000	1°	50	9
ZARM Technik	Digital AMR Magnetometer AMR-D-100-EFRS485	0.18	0.3 W	±100000	1°	unk	6-7



### 5.2.7 Sun Sensors

Sun sensors are used to estimate the direction of the Sun in a spacecraft body frame. Sun direction estimates can be used for attitude estimation, though to obtain a three-axis attitude estimate at least one additional independent source of attitude information is required (e.g., the Earth nadir vector or the direction to a star). Because the Sun is easily identifiable and extremely bright, Sun sensors are often used for fault detection and recovery. However, care must be taken to ensure the Moon or Earth's albedo is not inadvertently perturbing the measurement.

There are several types of Sun sensors which operate on different principles.

Cosine detectors are photocells. Their output is the current generated by the cell, which is (roughly) proportional to the cosine of the angle between the sensor boresight and the Sun. Typically several cosine detectors (pointing in different directions) are used on a spacecraft for full sky coverage. Cosine detectors (e.g., figure 5.5) are inexpensive, low-mass, simple and reliable devices, but their accuracy is typically limited to a few degrees, and they do require analog-to-digital converters.

Quadrant detectors. Quadrant sun sensors typically operate by shining sunlight through a square window onto a 2 x 2 array of photodiodes. The current generated by each photodiode is a function of the direction of the Sun relative to the sensor boresight. The measured currents from all four cells are then combined mathematically to produce the angles to the Sun.

Digital Sun Sensor. The Sun illuminates a narrow slit behind which, is located a geometric coded bit mask and a number of photodiodes under the mask. Depending on the angle to the Sun, the photodiodes will be illuminated as per the geometric pattern resulting in correspondingly different photocurrents which are then amplified and thresholded against an average value. Given the known slit geometries, this digital bit output can be then converted to a sun angle.

Sun Camera. Some sun sensors are build as a small camera imaging the Sun. Since the Sun is so bright, the optics will include elements to decrease the throughput. A computer will identify the image of the Sun and calculate the centroid. Sun sensors can be made very accurate this way. Sometimes, multiple apertures are included to increase accuracy.

Examples of small spacecraft sun sensors are described in table 5-7.



*Figure 5.5: Redwire Coarse Sun Sensor Detector (Cosine Type). Credit: Redwire Space.*

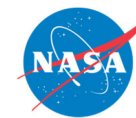
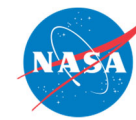
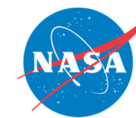


Table 5-7: Small Spacecraft Sun Sensors

Manufacturer	Model	Sensor Type	Mass (kg)	Peak Power (W)	Analog or Digital	FOV	Accuracy (3s)	# Measurement Angles	Radiation Tolerance (krad)	TRL
Redwire Space	Coarse Analog Sun Sensor	Coarse Analog Sun Sensor	0.045	0	Analog	±40° (Can be modified to meet specific FOV requirements)	±1°	1	>100	7-9
Redwire Space	Coarse Sun Sensor (Cosine Type)	Coarse Sun Sensor (Cosine Type)	0.010	0	Analog	APPROXIMATE COSINE, CONICAL SYMMETRY	±2° to ±5°	Depends on configuration	>100	7-9
Redwire Space	Coarse Sun Sensor Pyramid	Coarse Sun Sensor Pyramid	0.13	0	Analog	2π STERADIAN PLUS	±1° to ±3°	2	>100	7-9
Redwire Space	DIGITAL SUN SENSOR (±32°)	DIGITAL SUN SENSOR (±32°)	Sensor 0.3 kg Electronics ~1	1	Digital	±32° x ±32° (each sensor)	±0.125°	2	100	7-9
Redwire Space	Digital Sun Sensor (±64°)	Digital Sun Sensor (±64°)	Sensor 0.25 Electronics 0.29 - 1.1	0.5	Digital	128° X 128° (EACH SENSOR) NOTE: 4π STERADIANS ACHIEVED WITH 5 SENSORS	±0.25°	2	100	7-9
Redwire Space	Fine Pointing Sun Sensor	Fine Pointing Sun Sensor	Sensor .95 Electronics 1.08	< 3	Digital	±4.25° x ±4.25° (Typical)	Better than ±0.01°	2	100	7-9



Redwire Space	Fine Spinning Sun Sensor ( $\pm 64^\circ$ )	Fine Spinning Sun Sensor ( $\pm 64^\circ$ )	Sensor 0.109 Electronics 0.475 – 0.725	0.5	Analog and Digital	$\pm 64^\circ$ FAN SHAPED (each sensor)	$\pm 0.1^\circ$	1 plus Sun Pulse	100	7-9
Redwire Space	Micro Sun Sensor	Micro Sun Sensor	< 0.002	< 0.02	Analog	$\pm 85^\circ$ MINIMUM	$\pm 5^\circ$	2	Approx. 10	5-6
Redwire Space	Miniature Spinning Sun Sensor ( $\pm 87.5^\circ$ )	Miniature Spinning Sun Sensor ( $\pm 87.5^\circ$ )	< 0.25	0.5	Digital	$\pm 87.5^\circ$ (FROM NORMAL TO SPIN AXIS)	$\pm 0.1^\circ$	1 plus Sun Pulse	100	7-9
Redwire Space	FINE SUN SENSOR ( $\pm 50^\circ$ )	FINE SUN SENSOR ( $\pm 50^\circ$ )	Unk	Unk	Digital	100 X 100 Each Sensor	$\pm 0.01^\circ$ TO $\pm 0.05^\circ$	2	100, 150, or 300	7-9
Bradford Space	CoSS	Cosine	0.024	0	Analog	160° full cone	3°	1	40000	7-9
Bradford Space	CoSS-R	Cosine	0.015	0	Analog	180° full cone	3°	1	120000	7-9
Bradford Space	CSS-01, CSS-02 Only shows one CSS	Cosine	0.215	0	Analog	180° full cone	1.5°	2	70000	7-9
Bradford Space	FSS	Quadrant	0.375	0.25	Analog	128° x 128°	0.3°	2	100	7-9
Bradford Space	Mini-FSS	Quadrant	0.050	0	Analog	128° x 128°	0.2° With on-board implementation	2	20000	7-9
CubeSpace Satellite Systems	CubeSense	Camera	0.030	<0.2	Digital	180°	0.2°	2	24	7-9
GomSpace	NanoSense FSS	Quadrant	0.002	Unk	Digital	{45°, 60°}	{ $\pm 0.5^\circ$ , $\pm 2^\circ$ }	2	Unk	Unk



AAC Clyde Space	SS200	Unk	.003	0.04	Digital	110°	<1°	Unk	>36	7-9
Lens R&D	BiSon64-ET	Quadrant	0.023	0	Analog	±58° per axis	0.5°	2	9200	9
Lens R&D	BiSon64-ET-B	Quadrant	0.033	0	Analog	±58° per axis	0.5°	2	9200	8
Lens R&D	MAUS	Quadrant	0.014	0	Analog	±57° per axis	0.5°	2	9200	7-9
NewSpace Systems	NFSS-411	Unk	0.035	0.150	Digital	140°	0.1°	TBD	20	9
NewSpace Systems	NCSS-SA05	Unk	0.005	0.05	Analog	114°	0.5°	TBD	Unk	9
Solar MEMS Technologies	nanoSSOC-A60	Orthogonal	0.004	0.007	Analog	±60° per axis	0.5°	2	100	7-9
Solar MEMS Technologies	nanoSSOC-D60	Orthogonal	0.007	0.076	Digital	±60° per axis	0.5°	2	30	7-9
Solar MEMS Technologies	SSOC-A60	Orthogonal	0.025	0.01	Analog	±60° per axis	0.5°	2	100	7-9
Solar MEMS Technologies	SSOC-D60	Orthogonal	0.035	0.315	Digital	±60° per axis	0.5°	2	30	7-9
Solar MEMS Technologies	ACSS	Quadrant & Redundant	0.035	0.072	Analog	±60° per axis	0.5°	2	200	7-9
Space Micro	CSS-01, CSS-02	Cosine	0.010	0	Analog	120° full cone	5°	1	100	7-9
Space Micro	MSS-01	Quadrant	0.036	0	Analog	48° full cone	1°	2	100	7-9

### 5.2.8 Horizon Sensors

Horizon sensors can be simple infrared horizon crossing indicators (HCI), or more advanced thermopile sensors that can detect temperature differences between the poles and equator. For terrestrial applications, these sensors are referred to as Earth Sensors, but can be used for other planets. Examples of such technologies are described in table 5-8 and illustrated in figure 5.6.

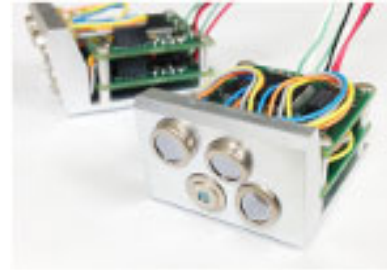


Figure 5.6: MAI-SES. Credit: Redwire Space.

In addition to the commercially-available sensors listed in table 5-8, there has been some recent academic interest in horizon sensors for CubeSats with promising results (24) (10) (11).

Table 5-8: Commercially Available Horizon Sensors									
Manufacturer	Model	Sensor Type	Mass (kg)	Peak Power (W)	Analog or Digital	Accuracy	# Measurement Angles	Rad Tolerance (krad)	T R L
CubeSpace Satellite Systems	CubeSense	Camera	0.030	0.200	Digital	0.2°	2	24	7-9
Servo	Mini Digital HCI	Pyroelectric	0.050	Voltage Dependent	Digital	0.75°	Unk	Unk	7-9
Servo	RH 310 HCI	Pyroelectric	1.5	1	Unk	0.015°	Unk	20	Unk
SITAEL	Digital Earth Sensor	Microbolometer	0.4	<2	Digital	<1°	Unk	Unk	Unk
Solar MEMS Technologies	HSNS	Infrared	0.120	0.150	Digital	1°	2	30	7-9



### 5.2.9 Inertial Sensing

Inertial sensors include gyroscopes for measuring angular change and accelerometers for measuring velocity change. They are packaged in different ways that range from single-axis devices (i.e., a single gyroscope or accelerometer), to packages which include 3 orthogonal axes of gyroscopes (Inertial Reference Unit (IRU)) to units containing 3 orthogonal gyros and 3 orthogonal accelerometers (Inertial Measurement Unit (IMU)). These sensors are frequently used to propagate the vehicle state between measurement updates of a non-inertial sensor. For example, star trackers typically provide attitude updates at a few Hertz. If the control system requires accurate knowledge between star tracker updates, then an IMU may be used for attitude propagation between star tracker updates.

Gyroscope technologies typically used in modern small spacecraft are fiber optic gyros (FOGs) and MEMS gyros, with FOGs usually offering superior performance at a mass and cost penalty (12). Other gyroscope types exist (e.g., resonator gyros, ring laser gyros), but these are not common in the SmallSat/CubeSat world due to size, weight, and power (SWaP) and cost considerations.

Gyro behavior is a complex topic (13) and gyro performance is typically characterized by a multitude of parameters. Table 5-9 only includes bias stability and angle random walk for gyros, and bias stability and velocity random walk for accelerometers, as these are often the driving performance parameters. That said, when selecting inertial sensors, it is important to consider other factors such as dynamic range, output resolution, bias, sample rate, etc.

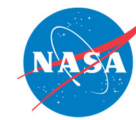
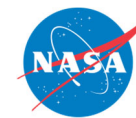


Table 5-9: Gyros Available for Small Spacecraft

Manufacturer	Model	Sensor Type	Technology	Mass (kg)	Power (W)	Gyros				Accelerometers			
						# Axes	Bias Stability		ARW	# Axes	Bias Stability		VRW
							(°/hr)	stat			(°/rt(hr))	(µg)	
Emcor	QRS11	Gyro	MEMS	≤0.06	0.8	1	6	Typical	N/A	N/A	N/A	N/A	N/A
Emcor	QRS28	Gyro	MEMS	≤0.025	0.5	2	N/A	N/A	N/A	N/A	N/A	N/A	N/A
Honeywell	MIMU	IMU	RLG	4	34	3	0.05	Unk	0.01	Unk	100	Unk	Unk
Honeywell	HG1700	IMU	RLG	0.9	5.000	3	1.000	1σ	0.125	3	1000	1σ	0.65
L3	CIRUS	Gyros	FOG	15.400	40.000	3	0.000	1σ	0.100	0	N/A	Unk	N/A
NewSpace Systems	NSGY-001	IRU	Image-based rotation estimate	0.055	0.200	3	N/A		N/A	0	N/A	Unk	N/A
Northrop Grumman	LN-200S	IMU	FOG, SiAc	0.748	12	3	1.000	1σ	0.070	3	300	1σ	Unk
NovAtel	OEM-IMU-STIM300	IMU	MEMS	0.055	1.50	3	0.500	TBD	0.150	3	50	TBD	0.060
Safran	STIM202	IRU	MEMS	0.055	1.500	3	0.400	TBD	0.170	0	N/A	TBD	N/A

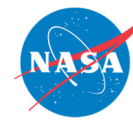


Safran	STIM210	IRU	MEMS	0.05 2	1.5 00	3	0.300	TB D	0.150	0	N/A	T B D	N/A
Safran	STIM300	IMU	MEMS	0.05 5	2.0 00	3	0.300	TB D	0.150	3	50	T B D	0.07
Safran	STIM318	IMU	MEMS	0.05 7	2.5 00	3	0.300	TB D	0.150	3	3	T B D	0.015
Safran	STIM320	IMU	MEMS	0.05 7	2.5 00	3	0.300	TB D	0.100	3	3	T B D	0.015
Safran	STIM277 H	IRU	MEMS	0.05 2	1.5 00	3	0.300	TB D	0.150	0	N/A	T B D	N/A
Safran	STIM377 H	IMU	MEMS	0.05 5	2.0 00	3	0.300	TB D	0.150	3	50	T B D	0.07
Silicon Sensin g System s	CRH03	Gyro	MEMS	0.42	0.2 W	1	CRH03- 010 – 0.03 CRH03- 025 – 0.04 CRH03- 100 – 0.04 CRH03- 200 – 0.05 CRH03- 400 – 0.1		CRH03- 010 – 0.005 CRH03- 025 – 0.006 CRH03- 100 – 0.006 CRH03- 200 – 0.008 CRH03- 400 – 0.010	0	N/A	-	N/A
Silicon Sensin g	CRH03 (OEM)	Gyro	MEMS	0.18	0.2 W	1	CRH03- 010 – 0.03		CRH03- 010 – 0.005	0	N/A	-	N/A



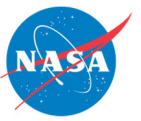


System s							CRH03-025 – 0.04 CRH03-100 – 0.04 CRH03-200 – 0.05 CRH03-400 – 0.1		CRH03-025 – 0.006 CRH03-100 – 0.006 CRH03-200 – 0.008 CRH03-400 – 0.010				
Silicon Sensing Systems	RPU30	Gyro	MEMS	1.35	<0.8W	3	0.06		0.006	0	N/A	-	N/A
Silicon Sensing Systems	DMU41	9 DoF IMU	MEMS	<2	<1.5W	3	0.1		0.015	3	15	-	0.05
Silicon Sensing Systems	CAS	Acc	MEMS	0.004	Unk	0	N/A		N/A	2	CAS2X1S - 7.5 CAS2X2S - 7.5 CAS2X3S - 7.5 CAS2X4S - 25 CAS2X5S - 75		CAS2X1S - TBC CAS2X2S - TBC CAS2X3S - TBC CAS2X4S - TBC CAS2X5S - TBC
Vector Nav	VN-100*	IMU + magnetometers	MEMS	0.015	0.220	3	10.000	max	0.210	3	40	max	0.082



		+barometer											
Vector Nav	VN-110*	IMU + magnetometers	MEMS	0.125	2.500	3	1.000	max	0.0833	3	10	max	0.024

\*Small form-factor versions of these products available.



### 5.2.10 GPS Receivers

For low-Earth orbit spacecraft, GPS receivers are now the primary method for performing orbit determination, replacing ground-based tracking methods. Onboard GPS receivers are now considered a mature technology for small spacecraft, and some examples are described in table 5-10. There are also next-generation chip-size COTS GPS solutions, for example the NovaTel OEM 719 board has replaced the ubiquitous OEMV1.

GPS accuracy is limited by propagation variance through the exosphere and the underlying precision of the civilian use C/A code (14). GPS units are controlled under the Export Administration Regulations (EAR) and must be licensed to remove Coordinating Committee for Multilateral Export Control (COCOM) limits (15).

Although the usability of GPS is limited to LEO missions, past experiments have demonstrated the ability of using a weak GPS signal at GSO, and potentially soon to cislunar distances (16) (17). Development and testing in this fast-growing area of research and development may soon make onboard GPS receivers more commonly available.

<b>Manufacturer</b>	<b>Model</b>	<b>Mass (kg)</b>	<b>Power (W)</b>	<b>Accuracy (m)</b>	<b>Radiation Tolerance (krad)</b>	<b>T R L</b>
APL	Frontier Radio Lite	0.4	1.4	15	20	5-6
General Dynamics	Explorer	1.2	8	15	Unk	7-9
General Dynamics	Viceroy-4	1.1	8	15	Unk	7-9
SkyFox Labs	piNAV-NG	0.024	0.124	10	30	7-9
Surrey Satellite Technology	SGR-Ligo	0.09	0.5	5	5	7-9
GomSpace	GPS-kit	0.031	1.3	1.5	Unk	Unk
Spacemanic	Celeste_gnss_rx	0.025	~0.1	1.5	40	7-9
AAC Clyde Space	GNSS-701	0.16	Unk	<5	10	7-9
Syrlinks	GPS (L1/L5) GALILEO (E1/E5/E6) BeiDou (B1/B3)	0.435	Unk	<0.1	15	5-6



### 5.2.11 Deep Space Navigation

In deep space, navigation is performed using radio transponders in conjunction with the Deep Space Network (DSN). As of 2020, the only deep space transponder with flight heritage suitable for small spacecraft was the JPL-designed and General Dynamics-manufactured Small Deep Space Transponder (SDST). JPL has also designed IRIS V2, which is a deep space transponder that is more suitable for the CubeSat form factor. Table 5-11 details these two radios, and the SDST is illustrated in figure 5.7. IRIS V2, derived from the Low Mass Radio Science Transponder (LMRST), flew on the MarCO CubeSats and is scheduled to fly on INSPIRE (18) and was selected for seven Artemis I secondary payloads slated for launch end of 2022 (27).



Figure 5.7: General Dynamics SDST. Credit: General Dynamics.

Manufacturer	Model	Mass (kg)	Power (W)	Bands	Radiation Tolerance (krad)	TRL
General Dynamics	SDST	3.2	12.5	X, Ka	50	7-9
Space Dynamics Laboratory	IRIS V2.1	1.1	35	X, Ka, S, UHF	15	7-9

### 5.2.12 Atomic Clocks

Atomic clocks have been used on larger spacecraft in low-Earth orbit for several years now, however integrating them on small spacecraft is relatively new. Table 5-12 provides examples of commercially available atomic clocks and oscillators for SmallSats. The conventional method for spacecraft navigation is a two-way tracking system of ground-based antennas and atomic clocks. The time difference from a ground station sending a signal and the spacecraft receiving the response can be used to determine the spacecraft's location, velocity, and (using multiple signals) the flight path. This is not a very efficient process, as the spacecraft must wait for navigation commands from the ground station instead of making real-time decisions, and the ground station can only track one spacecraft at a time, as it must wait for the spacecraft to return a signal (19). In deep space navigation, the distances are much greater from the ground station to spacecraft, and the accuracy of the radio signals needs to be measured within a few nanoseconds.

More small spacecraft designers are developing their own version of atomic clocks and oscillators that are stable and properly synchronized for use in space. They are designed to fit small spacecraft, for missions that are power- and volume-limited or require multiple radios.



Manufacturer	Model	Dimensions (mm)	Mass (kg)	Power (W)	Frequency Range	Rad Tolerance	TRL
AccuBeat	Ultra Stable Oscillator	131 x 120 x 105	2	6.5 W	57.51852 MHz	50	7-9
Bliley Technologies	Iris Series 1"x1" OCXO for LEO	19 x 11 x 19	0.016	1.5	10 MHz to 100 MHz	39	7-9
Bliley Technologies	Aether Series TCVCXO for LEO	21 x 14 x 8	Unk	0.056	10MHz to 150 MHz	37	Unk
Microsemi	Space Chip Scale Atomic Clock (CSAC)	41 x 36 x 12	0.035	0.12	10 MHz	20	5-6

### 5.2.13 LiDAR

Light Detection and Ranging (LiDAR) is new type of sensor that is emerging. The technology has matured in terrestrial applications (such as automotive applications) over the last decade and is used in larger spacecraft that are capable of proximity operations, like Orion. This sensor type has applications for small spacecraft altimetry and relative navigation (e.g., a Mars helicopter, rendezvous and docking, and formation flying). Table 5-13 lists examples of flown LiDARs.

Manufacturer	Model	Mass (kg)	Power (W)	Max Range (m)	Radiation Tolerance (krad)	TRL
Garmin	Lidar Lite V3	0.022	0.7	40	Unk	5-6*
ASC	GSFL-4K (3D)	3	30	>1 km in altimeter mode	Unk	7-9

\*Specific units were qualified for Mars Ingenuity helicopter. Product line in general is not space qualified.

### 5.3 On the Horizon

In general, technological progress in guidance, navigation, and control is advancing quickly in automotive research areas but is lagging slightly in the aerospace industry. Given the high maturity of existing GNC components, future developments in GNC are mostly focused on incremental or evolutionary improvements, such as decreases in mass and power, and increases in longevity and/or accuracy. This is especially true for GNC components designed for deep space missions that have only very recently been considered for small spacecraft. However, in a collaborative effort between the Swiss Federal Institute of Technology and Celeroton, there is progress being made on a high-speed magnetically levitated reaction wheel for small satellites (figure 5.8). The idea is to eliminate mechanical wear and stiction by using magnetic bearings rather than ball bearings. The reaction wheel implements a dual hetero/homopolar, slotless, self-bearing, permanent-magnet synchronous motor (PMSM). The fully active, Lorentz-type magnetic bearing consists of a heteropolar self-bearing motor that applies motor torque and radial forces on one side of the rotor's axis, and a homopolar machine that exerts axial and radial forces to allow active control of all six degrees of freedom. It can store 0.01 Nm of momentum at a maximum of 30,000 rpm, applying a maximum torque of 0.01 Nm (21)



Figure 5.8: High-speed magnetically levitated reaction wheel. Credit: Celeroton AG.

Several projects funded via NASA's Small Spacecraft Technology (SST) program through the Smallsat Technology Partnerships (STP) initiative have begun advancing GNC systems. Listed below in table 5-14 are projects that focused on GNC advancement, and further information can be found at the STP website:

[https://www.nasa.gov/directorates/spacetech/small\\_spacecraft/smallsat-technology-partnership-initiative](https://www.nasa.gov/directorates/spacetech/small_spacecraft/smallsat-technology-partnership-initiative)

Each presentation is from the STP Technology Exposition that was held in May 2021 and June 2022.

<b>Project</b>	<b>University</b>	<b>Current Status</b>	<b>Reference</b>
On-Orbit Demonstration of Surface Feature-Based Navigation and Timing	University of Texas, Austin	Still in development	<a href="#">STP Technology Expo presentation</a>
Autonomous Nanosatellite Swarming (ANS) using Radio Frequency and Optical Navigation	Stanford University	Flying on Starling mission (expected launch early 2023)	<a href="#">STP Technology Expo presentation</a>
Distributed multi-GNSS Timing and Localization (DiGiTaL)	Stanford University	Leveraged technology in Starling mission	<a href="#">STP Technology Expo presentation</a>
Mems Reaction Control and Maneuvering for Picosat beyond LEO	Purdue University	Awarded a suborbital flight test through NASA's Flight Opportunities program	(29)



A Small Satellite Lunar Communications and Navigation System	University of Boulder, Colorado	Still in development	<a href="#">STP Technology Expo presentation</a>
A high-precision continuous-time PNT compact module for the LunaNet small spacecraft	University of California, Los Angeles	Still in development	<a href="#">STP Technology Expo presentation</a>

## 5.4 Summary

Conventional small spacecraft GNC technology is a mature area, with many high TRL components previously flown around Earth offered by several different vendors. These GNC techniques are generally semi/non-autonomous as on-board observations are collected with the assistance of ground-based intervention. As the interest for deep space exploration with small spacecraft grows, semi-to-fully autonomous navigation methods must advance. It is likely that future deep space navigation will rely solely on fully autonomous GNC methods that require zero ground-based intervention to collect/provide navigation data. This is a desirable capability as the spacecraft's dependence on Earth-based tracking resources (such as DSN) is reduced and the demand for navigation accuracy increases at large distances from Earth. However, current methods advancing deep space navigation involve both ground- and space-based tracking in conjunction with optical navigation techniques. To support this maturity, the small spacecraft industry has seen a spike in position, navigation, and timing (PNT) technology progression in inertial sensors and atomic clocks, and magnetic navigation for near-Earth environments.

Other GNC advances involve research on SmallSats performing on-orbit proximity operations. Several research papers have discussed ways to accomplish this, and previous extravehicular free flyers have demonstrated this innovative capability in the past few decades. The CubeSat Proximity Operations Demonstration (CPOD) project is the most recent CubeSat mission to validate and characterize low-power proximity operations technologies. Launched in May 2022, CPOD will demonstrate the ability of two 3U CubeSats to remain at determined points relative to each other, as well as precision circumnavigation and docking. This mission aims to advance technologies for nanosatellite attitude determination, navigation and control systems, in addition to demonstrating relative navigation capabilities (28). Seeker, a 3U CubeSat that was deployed September 2019, was built to demonstrate safe operations around a target spacecraft with core inspection capabilities. While Seeker was unable to perform its underlining goal, there were still several benefits for improving future missions (29).

The rising popularity of SmallSats in general, and CubeSats in particular, means there is a high demand for components, and engineers are often faced with prohibitive prices. The Space Systems Design Studio at Cornell University is tackling this issue for GNC with their PAN nanosatellites. A paper by Choueiri et al. outlines an inexpensive and easy-to-assemble solution for keeping the ADCS system below \$2,500 (22). Lowering the cost of components holds exciting implications for the future and will likely lead to a burgeoning of the SmallSat industry.

For feedback solicitation, please email: [arc-sst-soa@mail.nasa.gov](mailto:arc-sst-soa@mail.nasa.gov). Please include a business email so someone may contact you further.

## References

- (1) L.C.G Shepherd. and A.F.S.C Shepherd. "Space Surveillance Network." Shared Space Situational Awareness Conference. Colorado Springs. 2006.



- (2) D. Vallado, P. Crawford, R. Hujak and T.S. Kelso. "Revisiting Spacetrack Report #3," AIAA 2006-6753. AIAA/AAS Astrodynamics Specialist Conference and Exhibit. August 2006. Thornton, C L and Border, J S: "Radiometric Tracking Techniques for Deep-Space Navigation." s.l: John Wiley & Sons, 2003.
- (3) JPL. "MarCO: Mission Overview. CubeSat." [Online] 2020. Available at: <https://www.jpl.nasa.gov/CubeSat/missions/marco.php>
- (4) J.R. Wertz. "Spacecraft attitude determination and control." Springer Science & Business Media. Vol. 73. 2012,
- (5) Jin, J, Ko, S and Ryoo, C K: "Fault Tolerant Control for Satellites with Four Reaction Wheels." vol. 16, no. 10, pp. 1250–1258. 2008.
- (6) R. Kulczycki and P. Wisniewski. "Slew Maneuver Control for Spacecraft Equipped with Star Camera And Reaction Wheels." Vol. 13, no. 3, pp. 349–356. 2005.
- (7) C.C. Liebe, "Star Trackers for Attitude Determination," IEEE Aerospace and Electronic Systems Magazine, vol. 10, no. 6, pp. 10-16, June 1995, doi: 10.1109/62.387971
- (8) M.L. Psiaki, F. Martel, F and P.K. Pal. "Three-Axis Attitude Determination Via Kalman Filtering of Magnetometer Data." Vol. 13, no. 3, pp. 506–514. 1990.
- (9) J.H. Wessels. "Infrared Horizon Sensor for CubeSat Implementation." Master's Thesis, Stellenbosch University. March 2018.
- (10) A. Pelemeshko et al. "High-Precision Cubesat Sun Sensor Coupled with Infrared Earth Horizon Detector." IOP Conf. Ser.: Mater. Sci. Eng. Vol. 734. pp. 0121-8. 2020,
- (11) D. Greenheck et al. "Design and Testing of a Low-Cost MEMS IMU Cluster for SmallSat Applications." 28th Annual AIAA/USU Conference on Small Satellites, 2014.
- (12) S. Merhav. "Aerospace Sensor Systems and Applications". Springer New York, 1998.
- (13) O. Montenbruck et al. "Precision Spacecraft Navigation Using a Low-Cost GPS Receiver." Vol. 16, no. 4, pp. 519–529. 2014.
- (14) "Foreign Availability Determination Procedures and Criteria." Office of the Federal Register. Title 15 Part 768.7. 2015.
- (15) J. Foust: "GPS in Space." MIT Technology Review. [Online] January 2002. <https://www.technologyreview.com/2002/01/01/275613/gps-in-space/>
- (16) A. Hadhazy. "Cosmic GPS." Aerospace America. [Online] May 2020. Available at: <https://aerospaceamerica.aiaa.org/features/cosmic-gps/>
- (17) F.H. Aguirre. "X-Band Electronics for The INSPIRE CubeSat Deep Space Radio." IEEE Aerospace Conference. 2015.
- (18) D. Baird. "NASA Tests Atomic Clock for Deep Space Navigation." [Online] 2018. Available at: <https://www.jpl.nasa.gov/news/news.php?feature=7053>
- (19) D. Cornwell. "NASA's Deep Space Atomic Clock and Optical Communications Program for PNT Applications." [Online] 2016. Accessed June 19, 2018. Available at: <https://www.gps.gov/governance/advisory/meetings/2016-12/cornwell.pdf>
- (20) J.W Kolar et al. "High-Speed Magnetically Levitated Reaction Wheels for Small Satellites." Anacapri, Capri: 23rd International Symposium on Power Electronics, Electrical Drives, Automation and Motion (SPEEDAM 2016), 2016.





- (21) M.N. Choueiri, M. Bell, and M.A. Peck. "Cost-Effective and Readily Manufactured Attitude Determination and Control System for NanoSatellites." AIAA/ASCE/AHS/ASC Structures, Structural Dynamics, and Materials Conference, AIAA SciTech Forum. 2018.
- (22) D. Dickinson. "NICER and SEXTANT demonstrate XNAV pulsar navigation system that may be used on Artemis." [Online] 2020. Available at: <https://skyandtelescope.org/astronomy-news/nasa-to-use-pulsar-navigation-for-deep-space-missions/>
- (23) K. Kapás, T. Bozóki, G. Dályá et al. "Attitude determination for nano-satellites – I. Spherical projections for large field of view infrasensors." Exp Astron 51, 515–527, 2021.
- (24) M. M. Kobayashi et al. "The Iris Deep-Space Transponder for the SLS EM-1 Secondary Payloads," in IEEE Aerospace and Electronic Systems Magazine, vol. 34, no. 9, pp. 34-44, 1 Sept. 2019.
- (25) NASA: "Deep Space Atomic Clock." [Online] 2021. Available at: <https://www.jpl.nasa.gov/missions/deep-space-atomic-clock-dsac>
- (26) M. M. Kobayashi et al., "The Iris Deep-Space Transponder for the SLS EM-1 Secondary Payloads," in IEEE Aerospace and Electronic Systems Magazine, vol. 34, no. 9, pp. 34-44, 1 Sept. 2019, doi: 10.1109/MAES.2019.2905923.
- (27) NASA. "CubeSat Proximity Operations Demonstration (CPOD)." [Online] July 1, 2022. Available at: [https://www.nasa.gov/directorates/spacetech/small\\_spacecraft/cpod\\_project.html](https://www.nasa.gov/directorates/spacetech/small_spacecraft/cpod_project.html)
- (28) S. M. Pedrotty, "Seeker Overview and Mission 1 Review-- A New Development Approach for In-Space Inspectors," [Online] 2021. Available at: <https://www.nasa.gov/smallsat-institute/seeker-overview-and-mission-1-review--a-new-development-approach-for-in-space-inspectors>
- (29) A.G. Cofer. "FILM EVAPORATION MEMS THRUSTER ARRAY FOR MICROPROPULSION." Open Access Dissertations. 1106. 2014. Available at: <https://core.ac.uk/download/pdf/220145833.pdf>



## Table of Contents

Glossary .....	ii
6.0 Structure, Mechanisms, and Materials .....	157
6.1 Introduction .....	157
6.2 State-of-the-Art – Primary Structures .....	158
6.2.1 CubeSat Structures .....	158
6.2.2 Mechanisms .....	162
6.3 State-of-the-Art – Additive Manufacturing .....	167
6.3.1 Applicability of TRL to Polymer AM .....	167
6.3.2 Thermoplastics and Photopolymers .....	168
6.3.3 AM Design Optimization .....	175
6.4 Radiation Effects and Mitigation Strategies.....	176
6.4.1 Shielding from the Space Environment .....	176
6.4.2 Inherent Mass Shielding .....	176
6.4.3 Shields-1 Mission, Radiation Shielding for CubeSat Structural Design ...	177
6.4.4 Ad Hoc Shielding .....	179
6.4.5 Charge Dissipation Coating .....	179
6.4.6 LUNA Innovations, Inc. XP Charge Dissipation Coating.....	179
6.5 Summary.....	180
References.....	180



## Glossary

(ABS)	Acrylonitrile Butadiene Styrene
(ACS3)	Advanced Composite Solar Sail System
(AE)	Aerospace Corporation Electron
(AM)	Additive manufacturing
(AMODS)	Autonomous On-orbit Diagnostic System
(AP)	Aerospace Corporation Proton
(CAM)	Computer Aided Manufacturing
(CFRP)	Carbon Fiber Reinforced Polymers
(CNC)	Computerized Numerical Control
(COBRA)	Compact On-Board Robotic Articulator
(COTS)	Commercial-off-the-shelf
(CSLI)	CubeSat Launch Initiative
(CTD)	Composite Technology Deployment
(CTE)	Coefficient of Thermal Expansion
(DCB)	Deployable Composite Boom
(DDD)	Displacement Damage Dose
(DLP)	Digital Light Projection
(DOF)	Degrees of Freedom
(EEE)	Electrical, Electronic and Electro-mechanical
(EELV)	Evolved Expendable Launch Vehicle
(ESD)	Electrostatic Discharge
(ESPA)	EELV Secondary Payload Adapter
(FDM)	Fused Deposition Modeling
(FFF)	Fused Filament Fabrication
(FPGAs)	Field Programmable Gate Arrays
(FST)	Flame, Smoke, and Toxicity
(GCD)	Game Changing Development
(GEVS)	General Environmental Verification Standard
(HDT)	Heat Deflection Temperature
(ISS)	International Space Station
(MOSFETs)	Metal Oxide Semiconductor Field Effect Transistors
(PAEK)	Polyaryletherketone
(PC)	Polycarbonate



(PCB)	Printed Circuit Board
(PEEK)	Polyetheretherketone
(PEI)	Polyetherimide
(PEKK)	Polyetherketoneketone
(PLA)	Polylactic Acid
(PLEO)	Polar Low-Earth Orbit
(PSC)	Planetary Systems Corporation
(RECS)	Robotic Experimental Construction Satellite
(ROC)	Roll Out Composite
(SADA)	Solar Array Drive Actuator
(SEUs)	Single Event Upsets
(SLA)	Stereolithography
(SLS)	Selective Laser Sintering
(SPEs)	Solar Particle Events
(STELOC)	Stable Tubular Extendable Lock-Out Composite
(TID)	Total Ionizing Dose
(TRAC)	Triangle Rollable and Collapsible
(TRL)	Technology Readiness Level
(ULA)	United Launch Alliance



## 6.0 Structure, Mechanisms, and Materials

### 6.1 Introduction

Material selection is of primary importance when considering small spacecraft structures. Requirements for both physical properties (density, thermal expansion, and radiation resistance) and mechanical properties (modulus, strength, and toughness) must be satisfied. The manufacture of a typical structure involves both metallic and non-metallic materials, each offering advantages and disadvantages. Metals tend to be more homogeneous and isotropic, meaning properties are similar at every point and in every direction. Non-metals, such as composites, are inhomogeneous and anisotropic by design, meaning properties can be tailored to directional loads. Recently, resin or photopolymer-based AM has advanced sufficiently to create isotropic parts. In general, the choice of structural materials is governed by the operating environment of the spacecraft, while ensuring adequate margin for launch and operational loading. Deliberations must include more specific issues, such as thermal balance and thermal stress management. Payload or instrument sensitivity to outgassing and thermal displacements must also be considered.

Additive manufacturing (AM) has increased custom structural solutions for SmallSats, and demonstrated high throughput of complex structures. Materials that were once out of reach of AM are now readily available in higher end systems. Once only for secondary structures, AM has seen an expansion in primary structures – especially in small CubeSat or PocketQube buses.

However, for larger CubeSats and Evolved Expendable Launch Vehicle (EELV) Secondary Payload Adapter (ESPA) SmallSats, conventionally machined assemblies constructed from aluminum alloys still have their place for primary structures. Secondary structures, such as solar panels, thermal blankets, and subsystems, are attached to primary structures. They stand on their own and transmit little to no critical structural loads. When a primary structure fails, catastrophic failure of the mission occurs, and while failure of a secondary structure typically does not affect the integrity of the spacecraft, it can have a significant impact on the overall mission. These structural categories serve as a good reference but can be hard to distinguish for small spacecraft that are particularly constrained by volume. This is especially true for SmallSats, as the capabilities of these spacecraft may be similar to full size buses, but the volume afforded by dispensers or deployment rings becomes the constraining factor. Therefore, it is imperative that structural components are as volume efficient as possible. The primary structural components need to serve multiple functions to maximize volume efficiency. Such functions may include thermal management, radiation shielding, pressure containment, and even strain actuation. These are often assigned to secondary structural components in larger spacecraft.

Structural design is not only affected by different subsystems and launch environments, but also the spacecraft application and intended environment. There are different configurations for spin-stabilized and 3-axis stabilized systems, and the instrumentation used places requirements on the structure. Some instruments require mechanisms, such as deployable booms, to create enough distance between a magnetometer and the spacecraft to minimize structural effects on the measurement. The spacecraft exterior and interior material and electronic subsystems need to be understood in the specific mission environment (e.g., in-space charging effects). Mitigation for charge build-up is provided in section 6.3.2 Thermoplastics and Photopolymers.

Highly configurable or modular systems may be desirable in quick-turn products, as prototyping and firmware and software development can be extended further into the spacecraft design cycle with flight hardware in the loop. Card slot systems not only provide those benefits, but when paired



with certain standards, they can still fulfill the same structural, mechanical, and thermal requirements as the current CubeSat method of “stacking” electronics and payloads.

An overview of radiation effects and some mitigation strategies is included in this chapter because radiation exposure can impact the structural design of small spacecraft. For SmallSats operating out of low-Earth orbit with increased radiation exposure, mission planners may also want to consider risk mitigation strategies associated with specific radiation environments. This includes both interplanetary missions, where solar radiation dominates, and polar low-Earth orbit (PLEO) missions, where solar radiation risk increases over the poles. In addition, as solar maximum approaches in 2025 (1) with an increased number of solar particle events (SPEs), mission planners will need to consider many orbital environments.

The information described below is not intended to be exhaustive but provides an overview of current state-of-the-art technologies and their development status for a particular small spacecraft subsystem. It should be noted that Technology Readiness Level (TRL) designations may vary with changes specific to payload, mission requirements, reliability considerations, and/or the environment in which performance was demonstrated. Readers are highly encouraged to reach out to companies for further information regarding the performance and TRL of described technology. There is no intention of mentioning certain companies and omitting others based on their technologies or relationship with NASA.

## **6.2 State-of-the-Art – Primary Structures**

Two general approaches are common for primary structures in the small spacecraft market: commercial-off-the-shelf (COTS) structures and custom machined or printed components. It is not surprising that most COTS offerings are for the CubeSat market. Often COTS structures can simplify development, but only when the complexity of the mission, subsystems, and payload requirements fall within the design intent of a particular COTS structure. Custom machined structures enable greater flexibility in mission specific system and payload design. The typical commercially available structure has been designed for low-Earth orbit applications and limited mission durations, where shielding requirements are confined to limited radiation protection from the Van Allen Belts.

There are now several companies that provide CubeSat primary structures (often called frames or chassis). Most are machined from aluminum alloy 6061 or 7075 and are designed with several mounting locations for components to allow flexibility in spacecraft configuration. This section highlights several approaches taken by various vendors in the CubeSat market. Of the offerings included in the survey, 1U, 3U and 6U frames are most prevalent, where a 1U is nominally a 10 x 10 x 10 cm structure. However, 12U frames are becoming more widely available. As there are now dispensers for the 12U CubeSat structure, there is an additional standard for CubeSat configurations. This trend has followed the development path of the 6U and 12U CubeSat structure, as 12U dispensers are now available through several launch service providers like NanoRacks and United Launch Alliance (ULA) through the Atlas series.

### **6.2.1 CubeSat Structures**

#### **Monocoque Construction**

Monocoque structures are load-bearing skins that have significant heritage on aircraft. On small spacecraft, the intent of this design is several-fold – it maximizes internal volume, it provides more thermal mass for heat sinks or sources, it allows for more mounting points, and it has more surface area to potentially reduce total ionizing dose (TID). Monocoque construction is common, and “extruded” designs are relatively easy to fabricate through computerized numerical control (CNC)

machining, waterjet, or laser cutting. The following are two examples of monocoque CubeSat structures.

### PUMPKIN, INC.

In the structural monocoque approach taken by Pumpkin for their 1U – 3U spacecraft, loads are carried by the external skin to maximize internal volume. Pumpkin provides several COTS CubeSat structures intended as components of their CubeSat Kit solutions, ranging in size from sub-1U to the larger 6U – 12U SUPERNOVA structures (2). Pumpkin offerings are machined from Al 5052-H32 and can be either solid-wall or skeletonized.

Pumpkin has developed the SUPERNOVA, a 6U and 12U structure that features a machined aluminum modular architecture. The 6U structure in figure 6.1 is designed to integrate with the Planetary Systems Corporation (PSC) Canisterized Satellite Dispenser and accommodates the PSC Separation Connector for power and data during integration (2). Configurations for other dispensers are also available.

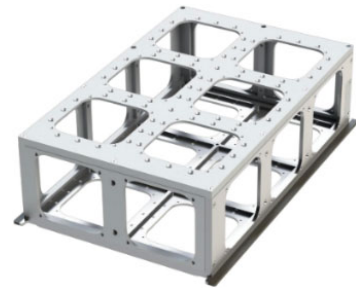


Figure 6.1: The 6U Supernova Structure Kit. Credit: Pumpkin, Inc.

### AAC CLYDE SPACE

AAC Clyde Space offers a ZAPHOD structure from 1U to 12U. The ZAPHOD structures have been redesigned to be lightweight and adaptable, simplifying modification and can be assembled around avionics stack and payload. AAC Clyde Space standardized their components to facilitate spacecraft configuration, as both 1U and 3U structures interface with all standard dispensers, such as NanoRacks (3). The 3U structure is shown in figure 6.2.



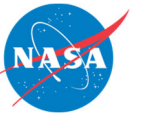
Figure 6.2: 3U structure. Credit: AAC Clyde Space.

### ISHITOSHI MACHINING, INC.

Ishitoshi Machining, Inc. uses CNC tooling techniques to make lightweight structures. The MBF-Mono base frame structure is built from a single aluminum block, and takes advantage of one-piece construction to improve structural properties and reduce weight (4).

### Modular Frame Designs

Modular frames allow for a flexible internal design for quick-turn missions, while still ensuring strict adherence to external dimensions of the CubeSat standard, especially when deployment from a standardized, reusable dispenser is required. Open frames are suitable for low-Earth orbit, as radiation shielding is not provided by the structure. Care must also be taken to design for thermal mass requirements, as modular frames are inherently light. The following subsections contain examples of modular CubeSat frame designs. Table 6-1 lists commercially available CubeSat structures.



### NANOAVIONICS MODULAR FRAME

NanoAvionics has developed what it calls “standardized frames and structural element” that, when assembled, form the primary structure for 1U to 16U spacecraft. A modular 3U structure from NanoAvionics is shown in figure 6.3. These components are intended to be modular, made from 7075 aluminum, and like many COTS CubeSat structures, compliant with the PC/104 form factor (5).

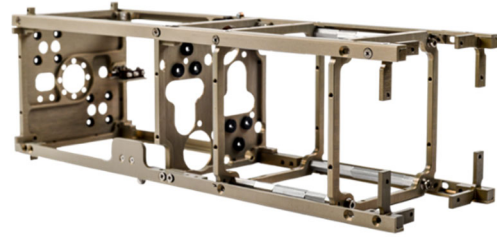


Figure 6.3: NanoAvionics Small Satellite Structures. Credit: NanoAvionics.

### INNOVATIVE SOLUTIONS IN SPACE

ISISPACE offers a wide array of CubeSat structures, with the largest being a 16U structure. Several of their 1U, 2U, 3U and 6U structures have been flown in low-Earth orbit. 12U and 16U structures have recently been added to the product line. Multiple mounting configurations can be considered to allow a high degree of creative flexibility with the ISISPACE design. Detachable shear panels allow for access to all the spacecraft’s electronics and avionics, even after final integration (6).

### GOMSPACE

GomSpace provides full turn-key solutions for small satellite systems. They offer modular nanosatellite structures from 1 – 6U with strong flight heritage. The 6U (figure 6.4) has a 4U payload allocation, mass of 8 kg, and propulsive configuration capabilities. The 3U structure was first deployed from the International Space Station (ISS) in 2015, and two 6U systems were deployed in early 2018 (7).

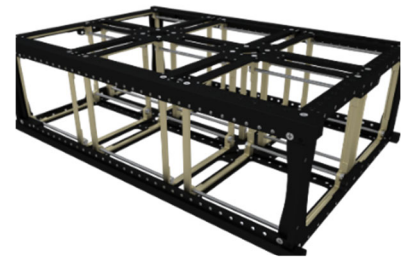


Figure 6.4: 6U nanosatellite structure. Credit: GomSpace.

### ENDUROSAT

EnduroSat provides 1U, 1.5U, 3U, 6U CubeSat structures and material; all EnduroSat structures are made of either Aluminum 6061-T651 or Al 7075. All the listed structures have undergone environmental qualification including vibrational, thermal and TVAC testing while the 1U structure and 3U structure also have flight heritage (8).

### SPACEMIND

Spacemind sells 1U, 1.5U, 3U, 6U, and 12U CubeSat structures. Structures have undergone environmental qualification including vibrational, thermal and TVAC testing. The structures have been designed for maximum accessibility for different electronic card and side panel options (9).

Manufacturer	Structure	Dimensions (mm)	Primary Structure Mass (kg)	Material
EnduroSat	1U	100 x 100 x 114	< 0.1	Al 6082
	1.5U	100 x 100 x 170.2	0.11	Al 6082
	3U	100 x 100 x 340	< 0.29	Al 6082
	6U	100 x 226 x 366	< 1	Al 6082
	12U	226.3 x 226.3 x 366	2.44	Al 6082





	16U	226.3 x 226.3 x 454	< 3	Al 6082
	1U	100 x 100 x 114	0.1	Al 6061
ISISPACE	2U	100 x 100 x 227	0.16	Al 6061
	3U	100 x 100 x 341	0.24	Al 6061
	6U	100 x 226 x 340.5	0.9	Al 6061
	8U	226 x 226 x 227	1.3	Al 6061
	12U	226.3 x 226 x 341	1.5	Al 6061
	16U	226.3 x 226.3 x 454	1.75	Al 6061
GomSpace	6U	340.5 x 226.3 x 100	1.06	Al 7075
Ishitoshi Machining	1U	100 x 100 x 113.5	0.1	A7075, A6061
NanoAvionics	1U	100 x 100 x 113.5	0.105	7075-T7351
	2U	100 x 100 x 227.0	0.208	7075-T7351
	3U	100 x 100 x 340.5	0.312	7075-T7351
Spacemind	1U	113.5 x 100 x 100	0.0849	Al 6061
	2U	227 x 100 x 100	0.0156	Al 6061
	3U	340.5 x 100 x 100	0.0226	Al 6061
	6U	F: 340.5 x 226.3 x 100 L: 366 x 226.3 x 100	0.055	Al 6061
	12U	340.5 x 226.3 x 226.3	0.143	Al 6061
C3S Electronics Development LLC	3U	100 x 100 x 340.5/ 366	0.580/ 0.614	High precision machining aluminum components with hard anodized rails
	6U	100 x 226.3 x 366	1.092	
	12U	226.3 x 226.3 x 366	2.353	
	16U	226.3 x 226.3 x 454	2.700	

### Custom CubeSat Primary Structures

A growing development in building custom small satellites is the use of detailed interface requirement guidelines. These focus on payload designs with the understanding of rideshare safety considerations for mission readiness and deployment methods. Safety considerations include safety switches, such as the "remove before flight" pins and foot switch, and requirements that the spacecraft remain powered-off while stowed in the deployment dispensers. Other safety requirements often entail anodized aluminum rails and specific weight, center of gravity, and external dimensions for a successful canister or dispenser deployment. The required interface documents originate with the rideshare integrator for the specific dispenser being used with the launch vehicle. The launch vehicle provider typically provides the launch vibrational conditions. The NASA CubeSat Launch Initiative (CSLI) requires CubeSat or SmallSat systems be able to withstand the General Environmental Verification Standard (GEVS) vibration environment of approximately 10  $G_{rms}$  over a 2-minute period (10). The NASA CSLI rideshare provides electrical safety recommendations for spacecraft power-off requirements during launch and initial deployment. The detailed dispenser or canister dimensional requirements provide enough

information, including CAD drawings in many cases, to enable a custom structural application. Table 6-2 lists some dispenser and canister companies that provide spacecraft physical and material requirements for integration.

<b>Table 6-2: Spacecraft Physical Dimension and Weight Requirements from Deployers</b>			
<b>Manufacturer</b>	<b>U</b>	<b>Requirements</b>	<b>Available Documents</b>
Tyvak Railpod III, 6U NLAS, 12U Deployer	3U, 6U, 12U	Dimensions, Weight, Rail	Interface Control Documentation (11)
Planetary Sciences Corporation	3U, 6U, 12U	Dimensions, Weight, Tabs	Interface Guide, CAD Drawings (12)
ISIPOD ISISPACE CubeSat Shop	1U, 2U, 3U, 4U, 6U, 8U, 12U, 16U	Dimensions, Weight, Rail	Follows CubeSat Standard (13)

### DiskSat Structure

The Aerospace Corporation is developing a DiskSat demonstration flight with support from NASA's Space Technology Mission Directorate (STMD). The DiskSat is a 1-m circular disk, 2.5 cm thick, graphite-epoxy composite sandwich, with a structural mass less than 3 Kg/m<sup>2</sup>. The volume is close to 20 liters, which is equivalent to a hypothetical '20U' spacecraft. While the entire volume will not be filled, the increased surface area is useful for power, aperture, thermal management, and for manufacturing simplification. First launch for the demonstration mission is planned for 2024 (14). See figure 6.5 for a comparative image of a DiskSat and a conventional CubeSat structure.



*Figure 6.5: Comparison of DiskSat structure to a 2U CubeSat structure. Courtesy of and reprinted by permission of The Aerospace Corporation.*

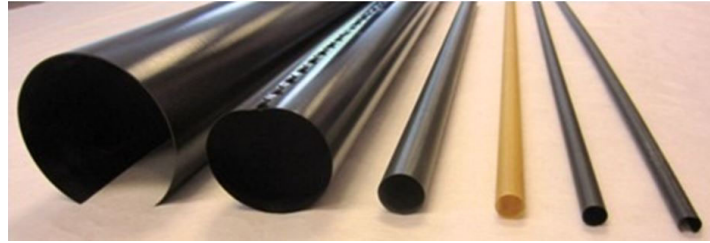
### 6.2.2 Mechanisms

There are several companies offering mechanisms for small spacecraft. Although not exhaustive, this section will highlight a few devices which represent the state-of-the-art for the CubeSat market, including mechanisms for release actuation, component pointing, robotic and boom extensions, and gimbal mechanisms. Please refer to the Deorbit Systems chapter for deployable mechanisms used for deorbit devices.

## Deployable Booms

### COMPOSITE TECHNOLOGY DEPLOYMENT (CTD)

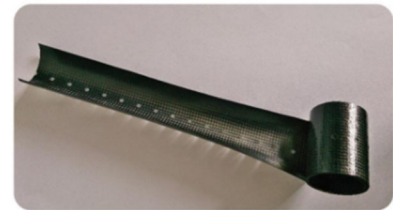
CTD has developed a composite boom called the Stable Tubular Extendable Lock-Out Composite (STELOC), that is rolled up or folded for stowage and deploys using stored strain energy. The slit-tube boom, shown in figure 6.6 employs an innovative interlocking SlitLock™ edge feature along the tube slit that greatly enhances stability. The boom can be fabricated in many custom diameters and lengths, offers a small stowed volume, and has a near-zero coefficient of thermal expansion (CTE) (15). This technology has flown in low-Earth orbit.



*Figure 6.6: CTD's Deployable Composite Booms. Credit: Composite Technology Development.*

### ALSAT-1N: ASTROTUBE DEPLOYABLE BOOM

Oxford Space Systems collaborated with the Algerian Space Agency to develop the AstroTube deployable boom (figure 6.7) that was recently demonstrated in low-Earth orbit on a 3U CubeSat called AISat-1N. It is the longest retractable boom that has been deployed and retracted on the 3U CubeSat platform. It incorporates a flexible, composite structure for the 1.5 m-long boom element and a novel deployment mechanism for actuation. When retracted, the boom is housed within a 1U volume and has a total mass of 0.61 kg (16).



*Figure 6.7: The flexible composite member that is employed on the AstroTube. Credit: Oxford Space Systems.*

### REDWIRE SPACE

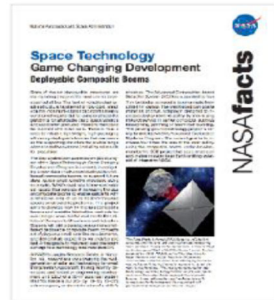
Redwire Space (previously ROCCOR) has developed several different deployable booms that have a wide range of applications on small spacecraft. The Roll Out Composite (ROC) booms are designed to deploy instruments or provide deployment force and structure to antennas, solar arrays, and other system architectures. These booms are 1-5 m in length and are fabricated from fiber reinforced polymer composites and can be tailored to meet a wide range of requirements for stiffness, force output, thermal stability, etc. These booms can also be either motor driven, or strain energy driven, and some versions have features for harness management. Furthermore, several versions of these booms can be made to retract on-orbit. There are currently three ROC booms in orbit, with other systems awaiting launch in 2022 (17).

The CubeSat ROC Boom Deployer is root rolled and motorized while the ROC-FALL system is tip-rolled and passively deployed. The CubeSat ROC Boom Deployer is awaiting a launch opportunity to reach TRL 7. In addition, there are additional mast boom capabilities by Redwire for booms that can extend from less than 1 m to 100m (18). The NASA GPX-2 CubeSat in operation used a Redwire deployable boom to create gravity gradient stabilization, see figure 6.8.



*Figure 6.8: GPX-2 CAD image with gravity gradient boom deployed. Image Credit: NASA.*

Redwire Space's family of robotic manipulators provide a wide range of capabilities, including 5 to 7 DOF, 1 to 4 m reach, and 8 to 65 kg mass, supporting a variety of orbital and lunar surface applications. The robotic arms are built from a suite of modular interchangeable elements, enabling variable reach, torque applications, configuration, and grappling capabilities. This technology is primarily for ESPA class satellites.



## NASA

NASA Langley Research Center (LaRC) has developed Deployable Composite Booms (DCB) through the Space Technology Mission Directorate (STMD) Game Changing Development (GCD) program and a joint effort with the German Aerospace Center, see figure 6.9. DCBs have high bending and torsional stiffness, packaging efficiency, thermal stability, and 25% less weight than metallic booms (19). The Advanced Composite Solar Sail System (ACS3) project will demonstrate DCB technology for solar sailing applications with an anticipated 2023 launch. The DCB/ACS3 7 m boom technology is extensible to 16.5 m deployable boom lengths (20).

Figure 6.9: NASA Deployable Composite Boom (DCB) Technology. Credit: NASA.

## BRIGHAM YOUNG UNIVERSITY (BYU)

The BYU origami structure with high-strain compliant composite joint uses carbon fiber reinforced polymers (CFRP) with joints under high strain as a deployment mechanism (see figure 6.10). One advantage of origami-inspired mechanisms is potentially faster and cheaper prototyping; Instead of relying on laser cutting or 3D-printing, prototyping of origami-inspired mechanisms can be accomplished using inexpensive materials like paper before moving to other more expensive materials. Many resources and patterns already exist that detail how designs can be created and modified or adapted for engineering purposes (21).

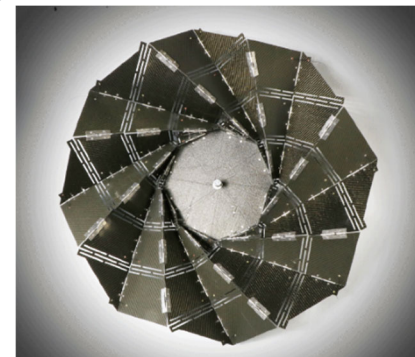


Figure 6.10: BYU composite origami structure. Credit: Compliant Mechanisms Research Group, Brigham Young University.

## Robotic Arms

### US NAVAL ACADEMY

Repair Satellite-Prototype (RSat-P) is a 3U CubeSat that is part of the Autonomous On-orbit Diagnostic System

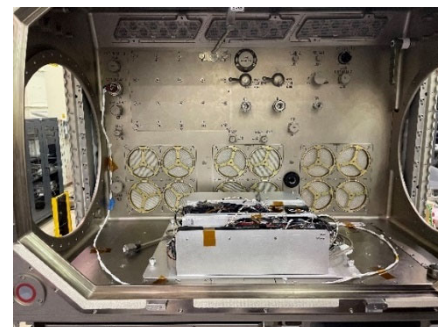


Figure 6.11: RSat payload mounted inside the MSG mockup on the ground for fit check. Credit: The Naval Academy.

(AMODS) built by the US Naval Academy Satellite Lab to demonstrate capabilities for on-orbit repair systems (22). RSat-P uses two 60 cm extendable robotic arms with the ability to maneuver around a satellite to provide images and other diagnostic information to a ground team. RSAT-P launched with the ELaNaXIX Mission in December 2018 and was lost during initial deployment. The robotic development has continued with the Naval Academy Satellite Team for Autonomous Robotics (NSTAR) Robotic/Repair Satellite (RSat), a 3U CubeSat (figure 6.11) which will demonstrate the robotic arm capabilities in the ISS microgravity environment in late 2022. The RSat robotic arms were built using 3D Windform print technology from RSat-P CubeSat heritage.

## SIERRA LOBO

Sierra Lobo has developed an arm for use inside volumes as small as a CubeSat. The Sierra Lobo Arm: Compact 1 (SLAC1) has a very small and retracted volume but can reach a comparably large work envelope. See table 6-3 for specifications. It has three degrees of freedom excluding the end effector. SLAC1 has simple inverse kinematics, which makes it suitable for autonomous or direct human control.

The arm can be used with special-purpose end effectors.

### Actuators

## TETHERS UNLIMITED

There are a few robotic actuator solutions offered by Tethers Unlimited (acquired by Amegint Technologies in May 2020) that are compact for small spacecraft. The Compact On-Board Robotic Articulator (COBRA) is a three degrees of freedom (3DOF) gimbal mechanism with two available configurations. A few of the varying specifications are found in table 6-4, and the HPX configuration is shown in figure 6.12. This mechanism provides accurate and continuous pointing for sensors and thrusters (23). Five COBRA gimbals have been deployed on-orbit over the past year, providing precision pointing for optical and high frequency RF satellite crosslinks on private small spacecraft missions.

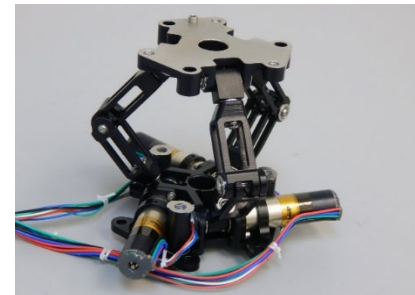


Figure 6.12: COBRA-HPX. Credit: Amegint Technologies, Inc.

The KRAKEN robotic arm is modular, with high-dexterity (up to 7 DOF) and will enable CubeSats to perform challenging missions, such as in-orbit assembly, satellite servicing, and debris capture. The standard configuration is a 1 m arm that can stow in a 190 x 270 x 360 mm volume with a mass of 5 kg. The TRL for this system is 6, assuming a low-Earth orbit environment (24).

The COBRA-Bee carpal-wrist mechanism was developed for the NASA Astrobee-- a small, free-flying robot that assists astronauts aboard the ISS. The COBRA-Bee gimbal can enable Astrobee to precisely point and position sensors, grippers, and other tools (25). COBRA-Bee is a small-scale, tightly integrated COTS product, that can provide precise multi-purpose pointing and positioning with an interface to support third-party sensors, end-effectors, and tools.

Parameter	Value
<b>Mass (kg)</b>	0.05
<b>Retracted dimensions (mm)</b>	25 x 30 x 60
<b>Working Envelope (mmm)</b>	100 x 100 x 100
<b>Maximum Power (mW)</b>	25
<b>Default-end Effector</b>	Three-finger claw
<b>Stall Torque (kg-mm)</b>	8

	<b>COBRA-UHPX</b>	<b>COBRA-HPX</b>
<b>Mass (kg) (with launch locks)</b>	0.491	0.276
<b>Stowed diameter footprint (mm)</b>	165	113
<b>Deployed Height (excl. launch locks)</b>	85.5	73.5
<b>Operating Temperature Range (°C)</b>	-35 to +70	-35 to +70
<b>Power Consumption</b>	Load Dependent	2.4 W
<b>Payload Capacity</b>	0.5 kg in 1G	1.2 kg in zero-G
<b>Actuator</b>	22 mm BLDC Motor	12 mm Stepper Motor
<b>TRL in LEO</b>	9	9

## HONEYBEE

Honeybee, in cooperation with MMA, has developed a CubeSat Solar Array Drive Actuator (SADA) that accommodates  $\pm 180^\circ$  single-axis rotation for solar array pointing, can transfer 100 W of power from a pair of deployed panels, and features an auto sun-tracking capability (26). Honeybee also offers the unit in a slip-ring configuration for continuous rotation. Table 6-5 highlights a few key specifications for this actuator. As of 2022, the SADA is in high-rate production for the OneWeb satellite internet constellation.

<b>Mass (slip ring option)</b>	0.18 kg
<b>Backlash</b>	< 3°
<b>Operating Temperature Range (°C)</b>	-30 to +85
<b>Size</b>	100 x 100 x 6.5 mm
<b>Radiation Tolerance</b>	10 kRad
<b>Wire Wrap (7 channels per wing)</b>	@ 1.4 A per channel
<b>Slip Ring (10 channels per wing)</b>	@ 0.5 A per channel
<b>TRL</b>	9
<b>Reference Mission(s)</b>	OneWeb

## ENSIGN-BICKFORD AEROSPACE & DEFENSE

EBAD's TiNi™ product line has a full array of small and reusable non-pyrotechnic actuators suitable for SmallSats. In particular, the Mini Frangibolt® (27) and MicroLatch (29) are suitable for CubeSat deployers or other high loading mechanical release mechanisms.

The Frangibolt operates by applying power to a Copper-Aluminum-Nickel memory shape alloy cylinder which generates

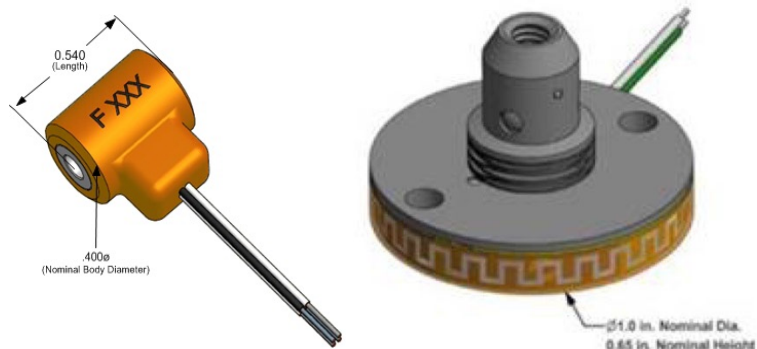


Figure 6.13: (left) TiNi Aerospace Frangibolt Actuator and (right) ML50 microlatch. Credit: Ensign-Bickford Aerospace & Defense.



force to fracture a custom notched #4 fastener in tension. The Frangibolt is intended to be reusable by re-compressing the actuator using a custom tool and replacing the notched fastener, and it has operated in low-Earth orbit on Pumpkin™ CubeSat buses. The ML50 Micro Latch is designed to release loads up to 50 lbf (222.4 N) and can support forces up to 100 lbf (445 N) during maximum launch conditions. A standard interface uses a 4-40 thread to attach a bolt or stud to the releasable coupling nut. Field resetting of the device is done simply by ensuring no more power is being sent to the device, placing the coupler back on the device, and hand pressing it until the coupler engages with the ball locks. Figure 6.13 shows a model of the FD04 Frangibolt actuator and a picture of the ML50 microlatch, and table 6-6 describes a few key specifications of both mechanisms.

<b>TiNi™ FD04 Frangibolt Actuator</b>		<b>TiNi™ ML50 Specifications</b>	
<b>Mass (kg)</b>	0.007	<b>Mass (kg)</b>	0.015
<b>Power C</b>	15 W @ 9 VD	<b>Power/Operational Current</b>	1.5 A to 3.75 A
<b>Operating Temperature Range (°C)</b>	-50 to +80	<b>Operating Temperature Range (°C)</b>	-50°C to +60
<b>Size</b>	13.72 x 10.16 mm	<b>Max Release Load</b>	222.4 N
<b>Holding Capacity</b>	667 N	<b>Max Torque</b>	106 N mm
<b>Function Time Typically</b>	20 sec @ 9 VDC	<b>Function Time Typically</b>	120 ms @ 1.75A (23°C)
<b>Life</b>	50 cycles MIN	<b>Life</b>	50 cycles MIN
<b>TRL</b>	9	<b>TRL</b>	9

### 6.3 State-of-the-Art – Additive Manufacturing

Additive manufacturing (AM) processes for primary spacecraft structures have long been proposed but only recently have such methodologies been adopted for flight. AM has been common for SmallSat secondary structural elements for many years. Typically, the advantage of AM is to free the designer from constraints imposed by standard manufacturing processes and allow for monolithic structural elements with complex geometry. In practice, additive manufacturing has a separate design space and design process, which has seen tighter integration into computer-aided design, computer-aided manufacturing, and modal and structural analysis packages in the past few years. Such tools can enable quicker turnaround times for SmallSat development, and have been instrumental in mass optimization, using AM materials in radiation shielding, and enabling high-throughput, high-quality manufacturing. As the AM field is rapidly evolving, this section makes a best attempt to cover as many materials and printers as possible that are potentially applicable to SmallSat development.

#### 6.3.1 Applicability of TRL to Polymer AM

While AM systems and platforms might be considered mature and of high TRL, the TRL of AM parts configured for spaceflight depends on the material, the configuration of the actual part, the manufacturing process of the material, the postprocessing of the manufactured part, the testing and qualification process, and many other factors. For example, nylon fabricated with a fused



filament fabrication (FFF) system will have different bulk structural properties from nylon fabricated with a selective laser sintering system.

In other words, a TRL might be assignable to a component created through a particular manufacturing process with a specific material. If a particular component manufactured with nylon on an FFF system was flown to LEO successfully, the TRL for this component would be 7. If this component was subsequently flown on another mission manufactured with Antero 840 PEEK also on an FFF system, the TRL would still be 7. Documentation of the manufacturing process is important to properly account for TRL. This section focuses on polymer AM and does not address metal AM for SmallSats.

### **Inspection and Testing**

When new materials and/or processes are used, testing must be performed to minimize risk and bridge the gap between TRL levels. In particular, the only way to validate a tailored structure, component, or material is through testing, especially if more freedom is allocated to research and development. For new material types, if there is latitude afforded in upfront research and development, mechanical, modal, and thermal tests should be performed to compare against a known, proven structural design.

#### **6.3.2 Thermoplastics and Photopolymers**

With the expansion of available open-source AM platforms in the last decade, thermoplastics and photopolymer materials have rapidly gained traction and acceptance in many applications ranging from mechanical validation and fit-checking to engineering-grade, low-rate production products. Photopolymer or “thermoset” resins and associated manufacturing processes have improved to the point where microfluidics experiments may be additively manufactured, with the microfluidics channels and growth chambers directly manufactured as one piece, as opposed to the more traditional microfluidics approach of machining a plastic block.

As of publication, there are three primary methods of conducting AM for plastics: FFF, which uses thermoplastics in either a spool or pellet form; stereolithography (SLA), which uses photopolymer resin; and selective laser sintering (SLS), which uses a fine powder. Within SLA, there are two methods of curing resin: digital light projection (DLP), which uses a very high-resolution LED matrix – a monochrome display – to cure the entire layer nearly instantly; and polyjets, which deposit resin from a line array of jets, much like an inkjet printer with a large print head.

Certain thermoplastics are quickly gaining acceptance for high-reliability parts and applications on Earth, although, as of this writing, they have yet to gain widespread acceptance for space applications. One reason for this is AM methods cannot yet produce surfaces as smooth as machined metals, which is often a requirement for parts with tight tolerances. However, some thermoplastics are machinable, such as Nylon or polyetherimide (PEI). Similar to the manufacture of cast iron parts, machining to a final, high tolerance specification may allow these thermoplastics to gain further acceptance.

Except for some large-format AM centers, almost all thermoplastics are manufactured in spools, and may or may not be packaged for proprietary solutions. For SLA, almost all resins are used specifically for commercial solutions and AM centers. Additionally, some manufacturers may mix in additives to enhance material properties or ease the printing process. Because of this, the following sections on each material include a table of materials for both open-source and commercial solutions, and selected properties of interest. Availability of recommended nozzle and bed temperature is indicative of the ability to be printed on an open-source machine, except otherwise noted in the material description. Materials are not picked according to preference but through availability of technical specifications and potential applicability. For various types of AM





solutions, readers are encouraged to use these sections as a rough guide for currently available commercial filaments. Additionally, the material tables will be expanded as more data is obtained on the following materials.

Surface discharge, or electrostatic discharge (ESD), is a result of in-space charging effects and is caused by interactions between the in-flight plasma environment and spacecraft materials and electronic subsystems (30). The field buildup and ESD can negatively affect the spacecraft and there are design precautions which must be considered depending on the spacecraft's operational environment. Per ESD guidelines from NASA Spacecraft Charging Handbook 4002A, dielectric materials above  $10^{12}$  Ohm ( $\Omega$ ) cm should be avoided because charge accumulation occurs regardless. Please refer to the NASA Handbook 4002A, 5.2.1.5 Material Selection for more information. Historically, ESD due to faulty grounding has been a leading cause of spacecraft or subsystem failures (30).

### Polylactic Acid (PLA)

PLA is the most common filament used in AM and table 6-7 lists several PLA filaments. It exhibits very low shrinkage and is extremely easy to print because it does not require a heated bed or build chamber and requires a relatively low extruder (nozzle) temperature. It also has low offgassing during printing, important in open-frame AM systems in rapid prototyping environments such as lab settings. Unless the application has a very short-term exposure to harsh conditions, and if the conditions are well characterized and controlled, it is not recommended to use PLA for an application beyond TRL 3-4. For laboratory settings in controlled environments not subject to excessive mechanical forces, ESD-compatible filaments are available.

Filament Name (Citation)	ISO 75/ASTM D648 Deflection Temp (°C)	ISO 179-1 Hardness (kJ/m <sup>2</sup> ) or Izod D256-10A (J/m)	ISO 527-1/ASTM D638 ZX Tensile strength (MPa)	ASTM D790/ISO 178 Flexural strength (MPa)	Nozzle Temp (°C)	Bed Temp (°C)	Density (g/cc)	ESD Risk* ( $\Omega$ -cm)
Prusament PLA	55	12 kJ/m <sup>2</sup>	57	N/A	215	50-60	1.24	No
Verbatim PLA	50	16 kJ/m <sup>2</sup>	63	N/A	210	50-60	1.24	No
ColorFabb PLA-PHA (31)	N/A	30 kJ/m <sup>2</sup>	61	89	210	50-60	1.24	No
Stratasys PLA (32)	51	27 kJ/m <sup>2</sup>	26	84	N/A	N/A	1.264	No, $10^{15}$
3DXSTAT™ ESD-PLA	55	N/A	55	95	210	23-60	1.26	Yes, $10^6$ - $10^9$



### Acrylonitrile Butadiene Styrene (ABS)

ABS has traditionally been the choice for higher strength, lightweight prints from the Fused Deposition Modeling (FDM) process in the open-source community. It is generally temperature resistant and UV resistant, but turns yellow and eventually becomes more brittle over time when exposed to sunlight. It is a marginally difficult filament to print, especially in open-frame systems. High temperature gradients during printing may cause warping as parts get larger. Enclosed AM systems with heated chambers print ABS well. Additionally, ABS shrinks 1 to 2 percent of its printed size upon cooling – the shrinkage varies from manufacturer to manufacturer. ABS has flown as the complete structure for KickSat-2, a FemtoSat deployer for chip-scale satellites (33). The single-use, short mission duration, and intricate dispenser frame made a conventionally machined deployer mass- and cost-prohibitive. Table 6-8 lists some examples of ABS filaments.

Filament Name	ISO 75/ASTM D648 Deflection Temp (°C)	ISO 179-1 Hardness (kJ/m <sup>2</sup> ) or Izod D256-10A (J/m)	ISO 527-1/ASTM D638 Tensile strength (MPa)	ASTM D790/ISO 178 Flexural strength (MPa)	Nozzle Temp (°C)	Bed Temp (°C)	Density (g/cc)	ESD Risk (Ω-cm)
Stratasys ABS-CF10	100	20-51 J/m	21	29-69	N/A	N/A	1.0972	Marginal 10 <sup>4</sup> -10 <sup>9</sup>
Stratasys ABS-ESD7	105	36.2 J/m	35	44	N/A	N/A	1.07	Marginal 10 <sup>4</sup> -10 <sup>9</sup>
3DXSTAT™ ESD-ABS	97	N/A	58	80	230	110	1.09	Yes, 10 <sup>6</sup> -10 <sup>9</sup>
Verbatim ABS	106 (ISO 306)	21 J/m	47	78	240-260	90	1.05	No

### Nylon

Versatile and tough, there are multiple formulations for nylon that allow for a very wide range of applications and material properties. In general, nylon is more difficult to manufacture than ABS on open-source FFF systems due to the need for an enclosure for thermal stability and additional bed preparation due to the need for higher adhesion. Secondary structural pieces have been flown through the TechEdSat program using Markforged Onyx carbon fiber filaments. Table 6-9 lists some examples of nylon filaments.

Filament Name (Citation)	ISO 75/ASTM D648 Deflection Temp (°C)	ISO 179-1 Hardness (kJ/m <sup>2</sup> ) or Izod D256-	ISO 527-1/ASTM D638 ZX Tensile	ASTM D790/ISO 178 Flexural strength (MPa)	Nozzle Temp (°C)	Bed Temp (°C)	Density (g/cc)	ESD Risk (Ω-cm)
--------------------------	---------------------------------------	---	--------------------------------	---	------------------	---------------	----------------	-----------------



		10A (J/m)	strength (MPa)					
Taulman3 D Alloy 910 (34)	82	N/A	56	N/A	250- 255	30-65	N/A	Unk
Taulman3 D Alloy 910 HDT (34)	112	N/A	56	N/A	285- 300	55	N/A	Unk
Taulman3 D Nylon 680 Food Grade (35)	N/A	N/A	47	N/A	250- 255	30-65	N/A	No
Markforged Onyx ESD (36)	138	44 J/m	52	83	N/A	N/A	1.2	Yes, 10 <sup>5</sup> -10 <sup>7</sup>
3DXTECH CARBONX ™ HTN+CF (37)	240	N/A	87	95	295	130	1.24	Marginal 10 <sup>9</sup>
Stratasys Nylon 12 (38)	92-95	71-138 J/m	33-42	55-57	N/A	N/A	1.01	No, 10 <sup>13</sup>

### Polycarbonate (PC)

Also known as Lexan™, this thermoplastic has some of the highest impact resistance, tensile strength, and temperature resistance available for most open source-based AM systems. After manufacturing, it is dimensionally stable and very stiff. However, it is difficult to print on open-frame, open-source AM systems due to very high warping especially when printing large components. Very high bed and nozzle temperatures are required, and poor adhesion to the bed is a typical issue. It is also highly hygroscopic; if possible, the filament should be baked out before printing, or should be kept in a dedicated dry box while printing. Certain filaments, like the Prusament PC Blend, have additives to mitigate some of the difficulties of printing PC. If PC is desired for a SmallSat structure, it should be printed on a commercial AM system. Table 6-10 lists some polycarbonate filaments.

Filament Name (Citation)	ISO 75/ASTM D648 Deflection Temp (°C)	ISO 179-1 Hardness (kJ/m <sup>2</sup> ) or Izod D256-10A (J/m)	ISO 527-1/ASTM D638 ZX Tensile strength (MPa)	ASTM D790/ISO 178 Flexural strength (MPa)	Nozzle Temp (°C)	Bed Temp (°C)	Density (g/cc)	ESD Risk (Ω-cm)
Prusament PC Blend (39)	113	No break for ISO 179	63	88-94	275	110	1.22	No



Prusament PC Blend Carbon Fiber (39)	114	35 kJ/m <sup>2</sup>	55-65	85-106	285	110	1.16	No
Stratasys PC (40)	143	27-77 J/m	60	75	N/A	N/A	1.20	No

### Windform

Manufactured by CRP Technology, these proprietary materials are classified as a carbon fiber reinforced polymer originally designed for the automotive racing industry. They are unique in that these composites are manufactured through SLS (41). This results in higher dimensional stability and more isotropic properties than FFF. Windform XT 1.0 and 2.0 have been used on CubeSat and PocketQube platforms and have flight heritage through KySat-2 launched on ELaNa IV, and TANCREDO-1, launched through the ISS via JEM in 2017 (42). Table 6-11 lists CRP Windform filaments. The NASA GPX-2 Windform XT 2.0 structure launched in July 2022 and is operational.

**Table 6-11: CRP Windform**

Filament Name (Citation)	ISO 75/ASTM D648 Deflection Temp (°C)	ISO 179-1 Hardness (kJ/m <sup>2</sup> ) or Izod D256-10A (J/m)	ISO 527-1/ASTM D638 ZX Tensile strength (MPa)	ASTM D790/ISO 178 Flexural strength (MPa)	Manufacturing process	Bed Temp (°C)	Density (g/cc)	ESD Risk (Ω-cm)
Windform XT 2.0 (42)	173	4.72 kJ/m <sup>2</sup>	84	133	N/A, SLS	N/A, SLS	1.097	Yes, 10 <sup>8</sup>
Windform RS (43)	181	10.8 kJ/m <sup>2</sup>	48-85	139	SLS	SLS	1.10	Yes, 10 <sup>8</sup>

### Polyetherimide

Polyetherimide (PEI), also known by the Saudia SABIC trade name Ultem™, is a very tough thermoplastic resin with high thermal and chemical stability. It is inherently flame-resistant and can be machined. Some formulations of PEI are FAA-approved for flame, smoke, and toxicity (FST), and may also have ESD formulations. PEI is also known for extremely low offgassing, crucial for optical components and sensitive scientific packages. PEI is a common bed material for higher end open-source FFF systems due to its adhesive properties with other thermoplastics at higher temperatures. PEI has similar characteristics to polyetheretherketone (PEEK). Due to these similarities, PEI is only practically printable on commercial FFF systems. Table 6-12 lists some PEI filaments.

**Table 6-12: PEI Filaments**

Filament Name (Citation)	ISO 75/ASTM D648 Deflection Temp (°C)	ISO 179-1 Hardness (kJ/m <sup>2</sup> ) or Izod D256-10A (J/m)	ISO 527-1/ASTM D638 ZX Tensile strength (MPa)	ASTM D790/ISO 178 Flexural strength (MPa)	Nozzle Temp (°C)	Bed Temp (°C)	Density (g/cc)	ESD Risk
THERMAX™ Ultem™ 9085	158	N/A	63	90	275	115	1.34	No
3DXSTAT™ Ultem™ 1010 CF- ESD (44)	205	N/A	62	115	395	150	1.34	Yes, 10 <sup>7</sup> - 10 <sup>9</sup>
Stratasys Ultem™ 1010 CG (45)	212	22-27 J/m	81	82-128	N/A	N/A	1.29	No, 10 <sup>14</sup>
Stratasys Ultem™ 9085 (46)	153	39-88 J/m	69	80-98	N/A	N/A	1.27	No, 10 <sup>15</sup>
Zortrax Z- PEI 9085 (47)	186	N/A	54	90	N/A	N/A	1.34	No

## PAEK

Polyetheretherketone (PEEK) and polyetherketoneketone (PEKK) – in the polyaryletherketone (PAEK) family – are the highest performing thermoplastics developed as of this writing. With certain additives and matrix materials, they can rival the strength of stainless steel and withstand over 200°C continuously in some formulations, after annealing. PEEK/PEKK are naturally flame-retardant; they are accepted for use in aviation ducting. They also achieve extremely low offgassing in operation, which makes these thermoplastics good candidates for compatibility with optical components in space. Due to the extreme conditions required for manufacturing and the very high filament cost, these materials are only practically available for printing in extremely robust commercial FFF systems with sealed and heated chambers. PEEK has heritage on long-term, external ISS experiments, and structural elements on the Juno spacecraft, making it suitable for extreme radiation environments (48). Table 6-13 lists some PAEK-based filaments.

**Table 6-13: PAEK-based Filaments**

Filament Name (Citation)	ISO 75/ASTM D648 Deflection Temp (°C)	ISO 179-1 Hardness (kJ/m <sup>2</sup> ) or Izod D256-	ISO 527-1/ASTM D638 ZX Tensile	ASTM D790/ISO 178 Flexural strength (MPa)	Nozzle Temp (°C)	Bed Temp (°C)	Density (g/cc)	ESD Risk (Ω-cm)
--------------------------	---------------------------------------	---	--------------------------------	---	------------------	---------------	----------------	-----------------



		10A (J/m)	strength (MPa)					
3DXSTAT™ ESD-PEEK (49)	140	N/A	105	141	380- 400	150	1.32	Yes, 10 <sup>7</sup> - 10 <sup>9</sup>
3DXSTAT™ ESD-PEKK	185	N/A	109	135	375	140	1.34	Yes, 10 <sup>7</sup> - 10 <sup>9</sup>
CarbonX™ CF PEKK- Aerospace	285	N/A	126	178	390	140	1.33	Yes, 10 <sup>7</sup>
Stratasys Antero 840 (50)	150	28-43 J/m	95	87-139	N/A	N/A	1.27	Yes, 10 <sup>4</sup> - 10 <sup>9</sup>
Zortrax Z- PEEK (51)	160	N/A	100	130	N/A	N/A	1.30	N/A

### Photopolymers

Otherwise known as “thermosets,” these materials are liquid polymers cured by an optical and thermal process. Compared to other AM processes, photopolymers and their manufacturing processes allow for superior isotropic material properties, very high resolution, and the ability to manufacture optical quality parts. Some formulations, especially from 3D Systems and Stratasys, are designed for extreme temperature resistance and strength, desirable in aerospace applications. In some cases, the listed heat deflection temperature (HDT) may be superior to those of PAEK. As previously discussed, there are three major methods of curing photopolymers, one of which is proprietary. Many photopolymers are specifically paired for commercial systems. As a result, the following table includes the commercial system associated with the photopolymer.

Some of the photopolymers listed below have several additional characteristics not listable in this table, including, but not limited to, elasticity, tear strength, optical clarity, water absorption, and medical grade certifications. Such characteristics may be useful for biological experiments in future SmallSats. Please consult the products’ specific websites and datasheets for additional information. Additionally, photopolymers have the advantage of being able to be mixed, in-situ, as the object is being manufactured. This allows for continuously varying material properties throughout the object. Table 6-14 lists some photopolymers.

Photopolymer Name (Citation)	ISO 75/ASTM D648 HDT (°C)	ISO 179- 1/ASTM D256- 10A (J/m)	ISO 527- 1/ASTM D638 Tensile (MPa)	ASTM D790 Flexural (MPa)	Density (g/cc) at 25°C	ESD Risk (Ω- cm)	Manufacturing and/or Machine Type
Accura Bluestone (52)	267-284	13-17	66-68	124- 154	1.78	ND	3D Systems ProX 800



VisiJet M2S-HT250 (53)	250	10	51	83	1.15	ND	3DS MJP 2500 Plus
DSM Somos® Watershed XC	50	25	50	69	1.12	ND	Stratasys V650 Flex SL
Henkel LOCTITE® IND402 A70 Flex (54)	N/A	N/A	5.5	N/A	1.068	ND	Several
Henkel LOCTITE® 3D 3843 (55)	80	54	60	81	N/A	ND	DLP SLA types only

### 6.3.3 AM Design Optimization

Design optimization is an integral part of manufacturing validation and testing. As previously discussed for AM, validation, testing, and optimization encompass all materials and manufacturing processes. Software platforms, especially those that integrate toolpathing generation, computer aided manufacturing (CAM), load analysis, and fill generation, help speed up this process. The inherent advantage of AM to allow monolithic structural elements implies a much-expanded design space compared to subtractive manufacturing. Software has kept up with the pace of manufacturing advances and incorporates tools to assist with AM designs.

The manufacturing ecosystem includes software ranging from simple CAM solutions generating toolpaths (G-code) to complete, structural analysis and high-fidelity manufacturing simulations. As of this writing, AM has gained significant traction and value in low-TRL demonstrations and physical validation, partly due to the ease of fabrication in typical AM ecosystems. It is beginning to displace traditional machining – “subtractive” manufacturing – as AM systems have matured enough to print advanced thermoplastics, resins, and metals.

#### Infill Patterns

Due to the flexibility that AM offers, new methods of lightweighting are now possible. “Lightweighting” refers to the reduction of mass of structural elements, without compromising structural integrity. The best examples of well-proven heritage methods of lightweighting are “honeycomb” sandwiched aluminum panels, subtractive machining, and truss structures. However, such methods have certain limitations. Honeycomb panels for example, do not have uniform, or isotropic, properties – they do not exhibit the same stiffness in all directions.

Lightweighting in AM encompasses what is called “infill,” or the internal structure of a hollow body or panel. With a minimal increase in mass, an internal structure manufactured with AM can vastly increase the strength of a body. Very recently, the AM community has renewed interest in the use of the gyroid pattern, discovered by NASA researcher Alan Schoen in 1970, due to the ease of generation in AM toolpath programs. Aside from honeycomb and gyroids, several options for infill exist. Different options are offered with different AM-focused software packages.

#### Digital Materials

Both honeycomb panels and AM parts with infill have a common repetitive unit cell. By repeating this unit cell throughout the interior of a part, or as a structure on its own, a larger structure can be made. Further, by defining properties into this unit cell, information can effectively be encoded into the design, allowing for differing behavior of different parts of the structure. Digital materials



can dramatically expand the design space of a structure, allowing for targeted optimization of various properties such as mass to strength ratios, structural lightweighting, and others. As previously discussed, with certain resin polyjet AM centers, resins can be mixed in real time to form an object that has continuously varying properties.

## 6.4 Radiation Effects and Mitigation Strategies

### 6.4.1 Shielding from the Space Environment

Radiation Shielding has been described as a cost-effective way of mitigating the risk of mission failure due to total ionizing dose (TID) and internal charging effects on electronic devices. In space mission analysis and design, the average historical cost for adding shielding to a mission is below 10% of the total cost of the spacecraft (56). The benefits include reducing the risk of early total ionizing dose electronics failures (57). Some of the key CubeSat and SmallSat commercial electronic semiconductor parts include processors, voltage regulators, and memory devices, which are key components in delivering science and technology demonstration data (58).

Shielding the spacecraft is often the simplest method to reduce both a spacecraft's ratio of total ionizing dose to displacement damage dose (TID/DDD) accumulation, and the rate at which single event upsets (SEUs) occur if used appropriately. Shielding involves two basic methods: shielding with the spacecraft's pre-existing mass (including the external skin or chassis, which exists in every case whether desired or not), and spot/sector shielding. This type of shielding, known as passive shielding, is only very effective against lower energy radiation, and is best used against high particle flux environments, including the densest portions of the Van Allen belts, the Jovian magnetosphere, and short-lived solar particle events. In some cases, increased shielding is more detrimental than if none was used, owing to the secondary particles generated by highly penetrating energetic particles. Therefore, it is important to analyze both the thickness and type of materials used to shield all critical parts of the spacecraft. Due to the strong omni-directionality of most forms of particle radiation, spacecraft need to be shielded from the full  $4\pi$  steradian celestial sphere. This brings the notion of "shielding-per-unit-solid-angle" into the design space, where small holes or gaps in shielding are often only detrimental proportionally to the hole's solid angle as viewed by the concerned  $\text{ipixwep}\$ \text{ipixsrng}\$ \text{erh}\$ \text{ipixslq iglrmep}\$, \text{EEE}$  components. Essentially, completely enclosing critical components should not be considered a firm design constraint when other structural considerations exist.

### 6.4.2 Inherent Mass Shielding

Inherent mass shielding consists of using the entirety of the pre-existing spacecraft's mass to shield sensitive electronic components that are not heavily dependent on location within the spacecraft. This often includes the main spacecraft bus processors, power switches, etc. Again, the notion of "shielding-per-unit-solid-angle" is invoked here, where a component could be well shielded from its "backside" ( $2\pi$  steradian hemisphere) and weakly shielded from the "front" due to its location near the spacecraft surface. It would only then require additional shielding from its front to meet operational requirements. The classic method employed here is to increase the spacecraft's structural skin thickness to account for the additional shielding required. This is the classic method largely due to its simplicity, where merely a thicker extrusion of material is used for construction. The disadvantage to this method is the material used, very often aluminum, is mass optimized for structural and surface charging concerns and not for shielding either protons/ions or electrons. Recent research has gone into optimizing structural materials for both structural and shielding concerns; currently an active area of NASA's Small Business Innovation Research (SBIR) program research and development.

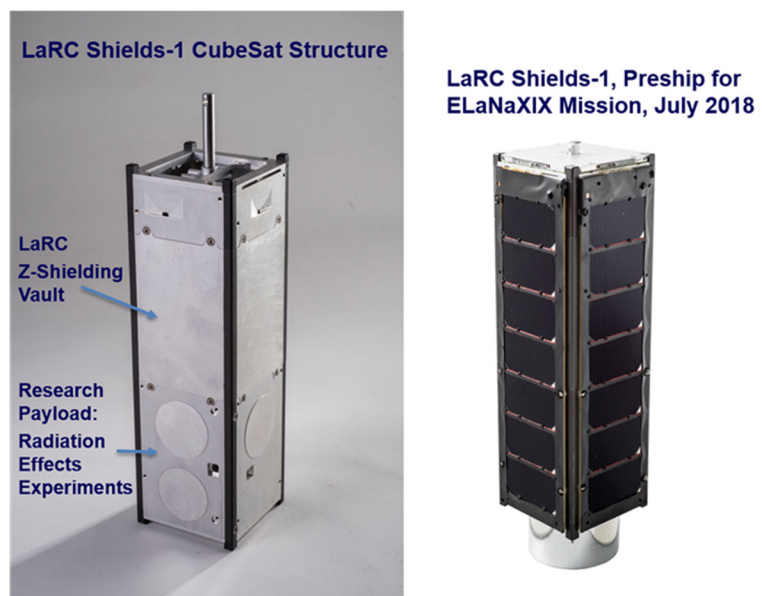


The process to determine exactly how much inherent shielding exists involves using a reverse ray tracing program on the spacecraft solid model from the specific point(s) of interest. After generating the "shielding-per-unit-solid-angle" map of the critical area(s) of the spacecraft, a trade study can be performed on what and where best to involve further additional shielding.

Numerous CubeSat and SmallSat systems use commercial processors, radios, regulators, memory, and SD cards. Many of these products rely on silicon diodes and MOSFETs) in these missions. A comprehensive NASA guidance document on the use of commercial electronic parts was published for the ISS orbit, which is a low-Earth orbit where the predominant radiation source is the South Atlantic anomaly. The hardness of commercial parts was noted as having a range from 2 – 10 kRad (59). For typical thin CubeSat shielding of 0.20 cm (0.080 in) aluminum, yearly trapped dose is 1383 Rad; with an additional estimated 750 Rad from solar particle events, the total dose increases to 2133 Rad for the ELaNaXIX Mission environment at 85 degrees inclination and 500 km circular orbit (table 6-16) (60). Adding a two-fold increase for the trapped belt radiation uncertainty brings the total radiation near the TID lifetime of many commercial parts (59), even before estimating a SPE TID contribution. The uncertainty of radiation model results of low-Earth orbit below 840 km has been estimated as at least two-fold; Van Allen Belt models are empirical and rely on data in the orbital environment (61). The NASA Preferred Reliability Series "Radiation Design Margin Requirements" also recommends a radiation design margin of 2 for reliability (62). Currently, The Aerospace Corporation proton (AP) (63) and The Aerospace Corporation electron (AE) (64) Models do not have radiation data below 840 km, and radiation estimates are extrapolated for the lower orbits (61). For spacecraft interplanetary trajectories near the Sun or Earth, the radiation contributions from SPEs will be higher than low-Earth orbit, where there is some limited SPE radiation protection by the magnetosphere. By reducing the total ionizing dose on commercial parts, the mission lifetimes can be increased by reducing the risk of electronic failures on sensitive semiconductor parts.

#### 6.4.3 Shields-1 Mission, Radiation Shielding for CubeSat Structural Design

Shields-1 has operated in polar low-Earth orbit and was launched through the ELaNaXIX Mission in December 2018. The Shields-1 mission increased the development level of atomic number (Z) Grade Radiation Shielding with an electronic enclosure (vault) and Z-grade radiation shielding slabs with aluminum baselines experiments (figure 6.14) (65). Preliminary results in table 6-15 show a significant reduction in total ionizing dose in comparison to typical modeled 0.20 cm (0.080 in) aluminum structures sold by commercial CubeSat providers. The 3.02 g cm<sup>-2</sup> Z-shielding vault has over 18 times reduction in total ionizing dose



Shields-1 structure and Final Preship Picture with LaRC Z-Shielding Vault and Experiment, Solar Panels and Thermal Radiator

Figure 6.14: Shields-1 Z-shielding structure and final Preship picture, ELaNaXIX Mission. Credit: NASA.



compared to modeled 0.20 cm aluminum shielding (60).

Z-shielding enables a low volume shielding solution for CubeSat and SmallSat applications where reduced volume is important. AlTiTa, Z-shielding, at 2.08 g cm<sup>-2</sup> reduces the dose from a SPE by half when compared to a standard 0.2 cm aluminum structure (figure 6.15). NASA has innovated “Methods of Making Z-Shielding” with patents in preparing different structural shieldings (66-69), from metals to hybrid metal laminates and thin structural radiation shielding, to enable low-volume integrated solutions with CubeSats and SmallSats (70).

Shielding	Areal Density (g/cm <sup>2</sup> )	Thickness (cm)	Trapped Belts TID Total (Rad (Si)/Year)	SPE King Sphere Model, (Rad (Si))
Al	0.535	0.198	1383+/-47 #	750+/-5
Al	1.26	0.465	<b>90.9 +/-2.7 (SL)</b>	432 +/- 7
Al	1.69	0.624	<b>84.3 +/-2.5 (SL)</b>	345 +/- 9
Al	3.02	1.11	<b>73.6 +/-3.2 (SL)</b>	183 +/- 11
AlTi	1.33	0.378	<b>89.7 +/-2.7 (SL)</b>	451 +/- 6
AlTiTa20	2.08	0.429	<b>84.3 +/-2.5 (SL)</b>	338 +/- 6
AlTiTa40	3.02	0.483	<b>81.9 +/-3.4 (SL) 75.6+/-3.2 (Vault)</b>	253 +/- 6

Shields-1 Experimental total ionizing dose measurements in PLEO in comparison to typical 0.20 cm aluminum shielding commercially available for CubeSats and SPE additional contributions to dose. **Bold values** Shields-1 experimental results. SL = Slab, Vault = Z-Shielding electronics enclosure. # sphere Space Environment Information System (SPENVIS) Multi-layered Shielding Simulation Software (MULASSIS) AP8 Min AE8 Max modeled results. SPE King Sphere Model SPENVIS MULASSIS modeled results.

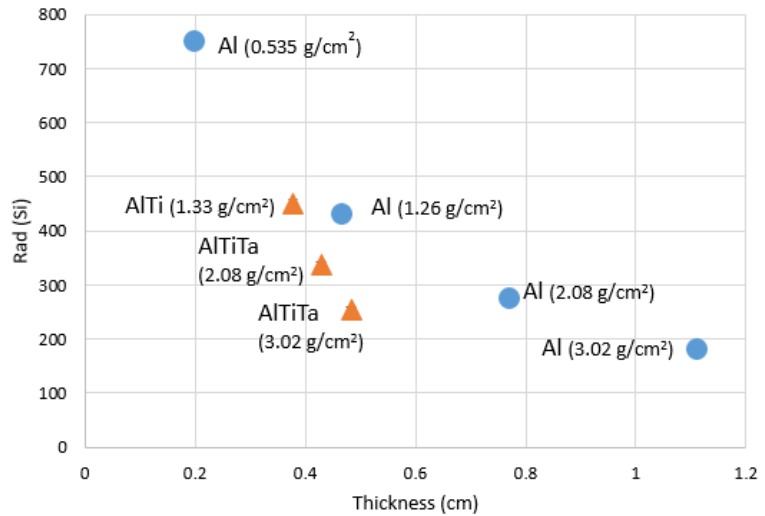


Figure 6.15: SPE Contribution to TID in PLEO, King Sphere Model, ELaNaXIX Shields-1 orbit. Credit: NASA.



#### 6.4.4 Ad Hoc Shielding

There are two types of ad hoc shielding used on spacecraft: spot shielding, where a single board or component is covered in shield material (often conformally), and sector shielding, where only critical areas of the spacecraft have shielding enhancement. These two methods are often used in concert as necessary to further insulate particularly sensitive components without unnecessarily increasing the overall shield mass and/or volume. Ad hoc shielding is more efficient per unit mass than inherent mass shielding because it can be optimized for the spacecraft's intended radiation environment while loosening the structural constraints. The most recent methods include: multiple layer shields with layer-unique elemental atomic numbers which are layered advantageously (often in a low-high-low Z scheme), known as "graded-Z" shielding, and advanced low-Z polymer or composite mixtures doped with high-Z, metallic micro-particles. Low-Z elements are particularly capable at shielding protons and ions while generating little secondary radiation, where high Z elements scatter electrons and photons much more efficiently. Neutron shielding is a unique problem, where optimal shield materials often depend on the particle energies involved. Commercial options include most notably Tethers Unlimited's VSRS system for small spacecraft, which was specifically designed to be manufactured under a 3D printed fused filament fabrication process for conformal coating applications (a method which optimizes volume and minimizes shield gaps).

#### 6.4.5 Charge Dissipation Coating

The addition of conformal coatings over finished electronic boards is another method to mitigate electrostatic discharge on sensitive electronic environments. Arathane, polyurethane coating materials (71), and HumiSeal acrylic coatings (72) have been used to mitigate discharge and provide limited moisture protection for electronic boards. This simple protective coating over sensitive electronic boards supports mission assurance and safety efforts. Charge dissipation films have decreased electrical resistances in comparison to standard electronics and have been described by NASA as a coating that has volume resistivities between  $10^8 - 10^{12}$  ohm-cm. In comparison, typical conformal coatings have volume resistivities from  $10^{12} - 10^{15}$  ohm-cm (30).

#### 6.4.6 LUNA Innovations, Inc. XP Charge Dissipation Coating

The XP Charge Dissipation Coating has volume resistivities in the range of  $10^8 - 10^{12}$  ohm-cm (table 6-16) and is currently developing space heritage through the NASA MISSE 9 mission and Shields-1 (73). The XP Charge Dissipation Coatings were developed through the NASA SBIR program from 2010 to present for extreme electron radiation environments, such as outer planets, medium-Earth, and geostationary orbits, to mitigate charging effects on electronic boards.

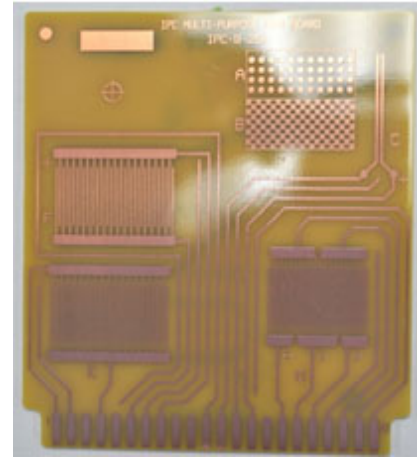
Material	Volume Resistivity (Ohm-cm)
XP Charge Dissipation Coating	$10^8 - 10^{12}$ , $4.7 \times 10^9$ at $25^\circ\text{C}$
Arathane 5750 A/B	$9.3 \times 10^{15}$ at $25^\circ\text{C}$ , $2.0 \times 10^{13}$ at $95^\circ\text{C}$
Humiseal 1B73	$5.5 \times 10^{14}$ Ohms (Insulation Resistance per MIL-I-46058C)

The LUNA XP Charge Dissipation Coating has reduced resistance compared to typical commercial conformal coatings as shown in table 6-17, which reduces surface charging risk on electronic boards. LUNA XP Coating (figure 6.16) on an electronic board has transparency for visual parts inspection. For extreme radiation environments, a combination of radiation shielding, and charge dissipation coating reduces the

ionizing radiation that contributes to charging and provides a surface pathway for removing charge to ground (30).

## 6.5 Summary

This chapter has been updated with the current status of structures, materials, and mechanisms for small satellite missions to the best of the author's capability. Additions include custom structure references with the dimensional and material requirements of integrating deployment systems, new mechanisms technology to reflect the ongoing growth in SmallSat mechanical devices, and more commercially procured deployable booms and larger CubeSat primary structures (12U and 16U), as well as the upcoming DiskSat structure. The radiation environment section, state-of-the-art radiation shielding and charge dissipation materials have been updated. Reflecting the fast pace of development in additive manufacturing, a selection of available thermoplastics and resin-based materials suitable for different TRL levels have been detailed.



*Figure 6.16: Transparent LUNA XP Charge Dissipation Coating on an electronic board. Credit: LUNA Innovations, Inc.*

There has been high focus on deployment mechanisms for small spacecraft subsystems related to: antennas booms, gravity gradient, stabilization, sensors, sails, and solar panels as examples. These technologies are gaining space heritage through operations and are developing in mission planning. The growth of these deployment mechanisms increase the capabilities of SmallSat technology and will be a continued focus in the next edition of this report.

For feedback solicitation, please email: [arc-sst-soa@mail.nasa.gov](mailto:arc-sst-soa@mail.nasa.gov). Please include a business email so someone may contact you further.

## References

- (1) Space Weather Prediction Center. Solar Cycle 25 Forecast Update. [Online] December 19, 2019. Available at: <https://www.swpc.noaa.gov/news/solar-cycle-25-forecast-update>
- (2) Pumpkin, Inc. CubeSat Kit Structures. Pumpkin Space Systems. [Online] 2017. Available at: [https://www.pumpkinspace.com/store/c4/CubeSat\\_Kit%E2%84%A2\\_Structures.html](https://www.pumpkinspace.com/store/c4/CubeSat_Kit%E2%84%A2_Structures.html)
- (3) AAC Clyde Space. CS 3U CubeSat Structure. Clyde Space. [Online] 2018. Available at: <https://www.aac-clyde.space/what-we-do/space-products-components/zaphod-range>
- (4) Ishitoshi Machining Inc. "MBF-Mono Base Frame." [Online] 2022. <http://www.ishitoshi.co.jp/en/>
- (5) NanoAvionics. "CubeSat Structural Frame." [Online] 2018. Available at: <https://nanoavionics.com/cubesat-components/cubesat-structural-frame/>
- (6) ISISPACE. "CubeSat Structures." [Online] Available at: <https://www.isispace.nl/product-category/cubesat-structures/>
- (7) GomSpace. "GomSpace's fourth Demonstration Mission is Successfully Launched – intended to Pioneer the Advanced." [Online] 2018. Available at: <https://gomspace.com/news/gomspaces-fourth-demonstration-mission-is-suc.aspx>



- (8) Endurosat. "CubeSat-3u-structure." [Online] 2017. Accessed July 15, 2018. Available at: <https://www.endurosat.com/products/CubeSat-3u-structure/>
- (9) NPC Spacemind. "Solutions in Space applications: Cubesat Products, Cubesat Structures." [Online] Available at: <https://www.npcspacemind.com/store/#!/Cubesat-Structures/c/43807390>
- (10) NASA Goddard Technical Standards, "GSFC General Environmental Verification Standard (GEVS) for GSFC Flight Programs and Projects", GSFC-STD-7000B, 28 April 2021.
- (11) Tyvak. "Launch Services". [Online] 2021. [Accessed: August 24, 2021. Available at: <https://www.tyvak.com/launch-services/>
- (12) Planetary Systems Corporation. "Canisterized Satellite Dispenser." [Online] Accessed: August 28, 2021. Available at: <https://www.planetarysystemscorp.com/product/canisterized-satellite-dispenser/>
- (13) ISISPACE. "CubeSat Deployers." [Online] Available at: <https://www.cubesatshop.com/wp-content/uploads/2016/07/ISIS-CubeSat-deployers-Brochure-v2-compressed.pdf>
- (14) R. Welle, C. Venturini, D. Hinkley, J. Gangestad, S. Grasso, A. Muszynski, R. Hunter, C. Frost, D. Mayer, and C. Baker, "DiskSat: Demonstration Mission for a Two-Dimensional Satellite Architecture," Proceedings of the AIAA/USU Conference on Small Satellites, Out of this World!, SSC22-VIII-01, 2022.
- (15) Composite Technology Development, Inc. "STELOC Deployable Composite Booms." [Online] 2018. Available at: <https://ctd-materials.com/engineered-materials/tembo/>
- (16) J. Reveles et al. "In-Orbit Performance of AstroTube: AISat Nano's Low Mass Deployable Composite Boom Payload." Proceedings of the AIAA/USU 31st Annual AIAA/USU Conference of Small Satellites, Logan, UT, 2017.
- (17) B.L. Davis, W.H. Francis, J.A. Goff, M.C. Cross, and D.J. Copel. "Big Deployables in Small Satellites", Proceedings of the AIAA/USU Conference on Small Satellites, The Commerce of Small Satellites, SSC12-XII-1, 2014.
- (18) Redwire Space. "Open Lattice Mast Boom (OLM)," [Online] 2022. Accessed October 2022. Available at: <https://redwirespace.com/products/open-lattice-mast-boom/?rdws=nnn.xffxcv.tfd&rdwj=57342-41850-43938-1-44045-35348-41850-41622>
- (19) NASA. "Deployable Composite Booms (DCB)." [Online]. August 26, 2020. Accessed May 18, 2021. Available at: [https://www.nasa.gov/directorates/spacetech/game\\_changing\\_development/projects/dc](https://www.nasa.gov/directorates/spacetech/game_changing_development/projects/dc)
- (20) NASA. "Advanced Composite Solar Sail System: Using Sunlight to Power Deep Space Exploration," [Online] June 23, 2021. Accessed October 2022. Available at: [https://www.nasa.gov/directorates/spacetech/small\\_spacecraft/ACS3/](https://www.nasa.gov/directorates/spacetech/small_spacecraft/ACS3/)
- (21) Brigham Young University. "Origami-Inspired Mechanisms Explained," [Online] 2022. Accessed October 2022. Available at: <https://www.compliantmechanisms.byu.edu/about-origami-mechanisms>
- (22) D.L. Wenberg, B.P. Keegan, M.E. Lange, E.A.S. Hanlon, and J.S. Kang. "RSat Flight Qualification and Test Results for Manipulable Robotic Appendages Installed on 3U CubeSat Platform." 30th Annual AIAA/USU Conference on Small Satellites, Logan, UT, 2016.
- (23) Tethers Unlimited, Inc. "Cobra Gimbal." [Online] 2018. Available at: <https://www.tethers.com/gimbals/>



- (24) Tethers Unlimited. "KRAKEN Robotic Arm." [Online] 2018. Accessed July 2018. Available at: [http://www.tethers.com/SpecSheets/Brochure\\_KRAKEN.pdf](http://www.tethers.com/SpecSheets/Brochure_KRAKEN.pdf)
- (25) Tethers Unlimited, Inc. COBRA-Bee Carpal-Wrist Gimbal for Astrobee. [Online] February 2017. Accessed July 18, 2018. Available at: <https://www.sbir.gov/sbirsearch/detail/1426639>
- (26) Honeybee Robotics. "Solar Array Drive Assemblies." [Online] 2018. Available at: <https://www.honeybeerobotics.com/products/solar-array-drive-assemblies/#1562267018138-ae149058-3c0374f5-d928>
- (27) Ensign-Bickford Aerospace & Defense. "TiNi™ Mini Frangibolt® Actuator: Small, Simple, Powerful." [Online] 2022. Available at: <https://www.ebad.com/tini-mini-frangibolt>
- (28) Ensign-Bickford Aerospace & Defense. "TiNi™ Micro Latch, Developed Specifically for "New Space" Applications." [Online] 2022. Available at: <https://www.ebad.com/tini-micro-latch/>
- (30) NASA. Technical Handbook, "Mitigating In-Space Charging Effects – A Guideline." NASA-HDBK-4002A. October 19, 2017.
- (31) ColorFabb. "PLA/PHA." Technical Datasheet, [Online] April 8, 2020. Available at: [https://colorfabb.com/media/datasheets/tds/colorfabb/TDS\\_E\\_ColorFabb\\_PLA\\_PHA.pdf](https://colorfabb.com/media/datasheets/tds/colorfabb/TDS_E_ColorFabb_PLA_PHA.pdf)
- (32) Stratasys. "PLA: Economy Thermoplastic for Stratasys F123 Series Printers." Technical Datasheet 2018. Available at: <https://stratasysstorage01.file.core.windows.net/ssys-websites-files-prod/Public1/Materials/FDM/PLA/PLA%20-%20EN%20Data%20Sheet%20FDM%20Material.pdf?sv=2017-04-17&sr=f&sig=colFyWKHlkaQ9GUZsyg0%2FFwD%2FIlpuff2a2SR%2FYKqFEg%3D&st=2022-11-27T23%3A00%3A27Z&se=2023-11-28T23%3A00%3A27Z&sp=rwl>
- (33) NASA. "What is KickSat-2?" [Online] June 3, 2019. Accessed July 12, 2021. Available at: <https://www.nasa.gov/ames/kicksat>
- (34) Taulman3D. "Alloy 910 Specifications." [Online] Accessed July 12, 2021. Available at: <https://taulman3d.com/alloy-910-spec.html>
- (35) Taulman3D. "Alloy 680 Specifications." [Online] Accessed July 12, 2021. Available at: <https://taulman3d.com/nylon-680-spec.html>
- (36) Markforged. "Onyx ESD™." Technical Datasheet, [Online] Accessed July 12, 2021. Available at: <https://markforged.com/materials/plastics/onyx-esd>
- (37) 3DXTech Additive Manufacturing. "CARBONX HTN+CF [HIGH TEMP CF NYLON]." [Online] Accessed July 12, 2021. Available at: <https://www.3dxtech.com/product/carbonx-htn-cf/>
- (38) Stratasys. "Nylon 12." [Online] Accessed July 12, 2021. Available at: <https://www.stratasys.com/materials/search/fdm-nylon-12>
- (39) Prusa Polymers. "Prusament PC Blend." Technical Datasheet, [Online] Available at: [https://prusament.com/media/2022/10/PCBlendCF\\_Prusament\\_TDS\\_2022\\_16\\_EN.pdf](https://prusament.com/media/2022/10/PCBlendCF_Prusament_TDS_2022_16_EN.pdf)
- (40) Stratasys. "PC (Polycarbonate): FDM Thermoplastic Filament." Technical Datasheet, [Online] Accessed July 12, 2021. Available at: [https://www.stratasys.com/-/media/files/material-spec-sheets/mds\\_fdm\\_pc\\_0920a.pdf](https://www.stratasys.com/-/media/files/material-spec-sheets/mds_fdm_pc_0920a.pdf)
- (41) CRP Technology. "High performance composite materials for SLS." [Online] 2018. Available at: <https://www.windform.com/top-line/#strength>
- (42) CRP Technology. "Windform 3D Printing materials launch into Orbit on KySat-2." [Online]. Accessed July 12, 2021. Available at: <https://www.crp-usa.net/windform-3d-printing-materials-launch-orbit-kysat-2/>



- (43) CRP Technology. "Winform XT 2.0" Technical Datasheet, [Online] Accessed July 12, 2021. Available at: <http://www.windform.com/windform-xt-2-0.html>
- (44) CRP Technology. "Winform RS" Technical Datasheet, [Online] Accessed July 12, 2021. Available at: <http://www.windform.com/windform-rs.html>
- (45) 3DXTech Additive Manufacturing. "3DXSTAT™ ESD-Ultem™ 3D Printing Filament." Technical Datasheet, [Online] Available at: [https://www.3dxtech.com/wp-content/uploads/2020/11/ESD\\_Ultem\\_v3.pdf](https://www.3dxtech.com/wp-content/uploads/2020/11/ESD_Ultem_v3.pdf)
- (45) Stratasys. "ULTEM 1010 Resin" [Online] Accessed July 12, 2021. Available at: <https://www.stratasys.com/en/materials/materials-catalog/fdm-materials/ultem-1010/>
- (46) Stratasys. "ULTEM 9085 Resin" [Online] Accessed July 12, 2021. Available at: <https://www.stratasys.com/en/materials/materials-catalog/fdm-materials/ultem-9085/>
- (47) Zortrax. "Aerospace-Grade Flame-Retardant Filament." Technical Datasheet, [Online] October 9, 2020, Updated June 22, 2021. Available at: [https://cf.zortrax.com/wp-content/uploads/2020/10/Z-PEI\\_9085\\_Technical\\_Data\\_Sheet\\_eng.pdf](https://cf.zortrax.com/wp-content/uploads/2020/10/Z-PEI_9085_Technical_Data_Sheet_eng.pdf)
- (48) TechBriefs. "Plastic Components Ride Juno Spacecraft to Jupiter." [Online] August 1, 2012. Available at: <https://www.techbriefs.com/component/content/article/tb/pub/features/applications/14486>
- (49) 3DXTech Additive Manufacturing. "3DXSTAT™ ESD-PEEK 3D Printing Filament." [Online] Available at: <https://www.3dxtech.com/product/3dxstat-esd-peek/>
- (50) Stratasys. "Antero 840CN03 High-Performance PEKK-Based ESD Thermoplastic." [Online] Accessed July 12, 2021. Available at: <https://www.stratasys.com/materials/search/antero-840cn03>
- (51) Zortrax. "Z-PEEL." [Online] Accessed July 12, 2021. Available at: <https://zortrax.com/filaments/z-peek/>
- (52) 3D Systems Inc. "Accura Bluestone Technical Data." [Online] September 2020. Available at: <https://www.3dsystems.com/sites/default/files/2020-11/3d-systems-accura-bluestone-datasheet-usen-2020-09-15-a-print.pdf>
- (53) 3D Systems, Inc. "VisiJet M2S-HT250 (MJP)." [Online] Accessed June 24, 2021. Available at: <https://www.3dsystems.com/materials/visijet-m2s-ht250>
- (54) Henkel Corporation, Loctite. "IND402TM: PhotoElastic A70 High Rebound Black." Technical Datasheet, [Online] March 22, 2022. Available at: [https://www.loctiteam.com/wp-content/uploads/2022/03/Loctite-3D-IND402-A70-High-Rebound-2022\\_03\\_22.pdf](https://www.loctiteam.com/wp-content/uploads/2022/03/Loctite-3D-IND402-A70-High-Rebound-2022_03_22.pdf)
- (55) Stratasys. "LOCTITE ® 3D3843 High Toughness by Henkel." [Online] Available at: <https://www.stratasys.com/en/materials/materials-catalog/p3-materials/loctite-3d-3843-high-toughness/>
- (56) J.R. Wertz and W.J. Larson. "Space Mission Analysis and Design, Third Edition." Space Technology Library, Space Technology Series, Hawthorne, CA: Microcosm Press and New York: Springer, 1999, p.976.
- (57) D. Hastings and H. Garrett, "Spacecraft Environment Interactions." New York, NY: Cambridge University Press, 1996, p.292.
- (58) M. Langer and M. Boumeester. "Reliability of CubeSats – Statistical Data, Developers' Beliefs and the Way Forward", 30th Annual AIAA/USU Conference on Small Satellites, August 2016, Logan, UT, SSC16-X-2, 1-12.
- (59) NASA Preferred Reliability Series PD 1258, "Space Radiation Effects on Electronic Components in Low Earth Orbit", August 1996.



- (60) D.L. Thomsen. "Shields-1 Preliminary Radiation Shielding Dosimetry in Polar Low Earth Orbit", Committee on Space Research (COSPAR), Small Satellites for Sustainable Science and Development, Herzliya, Israel, 7 November 2019.
- (61) Vampola, A. L. "The Space Particle Environment", NASA/SDIO Space Environmental Effects on Materials Workshop, NASA Conference Proceedings 3035, part 2, NASA Langley Research Center, Hampton, VA June 28 – July 1, 1988, pg. 367.
- (62) NASA Preferred Reliability Series PD 1260, "Radiation Design Margin Requirement", May 1996.
- (63) D.M. Sawyer and J.I. Vette, "AP-8 Trapped Proton Environment for Solar Maximum and Solar Minimum." NSSDC/WDC-A-R&S 76-06, 1976.
- (64) J.I. Vette. "The AE-8 Trapped Electron Model Environment." NSSDC/WDC-A-R&S 91-24, 1991a.
- (65) D.L. Thomsen III, W. Kim, and J.W. Cutler. "Shields-1, A SmallSat Radiation Shielding Technology Demonstration", 29th AIAA/USU Conference on Small Satellites, SSC15-XII-9, August 2015.
- (66) D.L. Thomsen III, R.J. Cano, B.J. Jensen, S.J. Hales, and J.A. Alexa. "Methods of Making Z-Shielding." U.S. Patent No. 8,661,653, 4 March 2014.
- (67) U.S. Patent No. 10,039,217, July 31, 2018, "Methods of Making Z-Shielding." D.L. Thomsen III, R.J. Cano, B.J. Jensen, S.J. Hales, and J.A. Alexa.
- (68) D.L. Thomsen III. "Method of Making Thin Atomic (Z) Grade Shields." U.S. Patent No. 10,600,52212, March 24, 2020.
- (69) D.L. Thomsen III, S.N. Sankaran, and J.A. Alexa. "Atomic Number (Z) Grade Shielding Materials and Methods of Making Atomic Number (Z) Grade Shielding." U.S. Patent No. 10,919,650, February 16, 2021.
- (70) D.L. Thomsen III and W.R. Girard. "Method of Making Atomic Number (Z) Grade Small SAT Radiation Shielding Vault." U.S. Patent No. 11,043,311, June 22, 2021.
- (71) Arathane. [Online] Available at: [https://apps.huntsmanservice.com/WebFolder/ui/browse.do?pFileName=/opt/TDS/Huntsman%20Advanced%20Materials/English%20US/Long/Arathane%205750%20AB\\_LV\\_US\\_e.pdf](https://apps.huntsmanservice.com/WebFolder/ui/browse.do?pFileName=/opt/TDS/Huntsman%20Advanced%20Materials/English%20US/Long/Arathane%205750%20AB_LV_US_e.pdf)
- (72) Chase Electronic Coatings. "HumiSeal® 1B73 Acrylic Conformal Coating Technical Data Sheet." [Online] Available at: <https://chasecorp.com/humiseal1/wp-content/uploads/sites/12/2018/10/1B73-TDS.pdf>
- (73) LUNA. "Luna coating provides radiation protection in space." [Online] February 2, 2018. Accessed June 28, 2020. Available at: <https://lunainc.com/blog/luna-coating-provides-radiation-protection-space>





## Chapter Contents

Chapter Glossary .....	ii
7.0 Thermal Control.....	185
7.1 Introduction .....	185
7.2 State-of-the-Art – Passive Systems .....	186
7.2.1 Paints, Coatings, and Tapes.....	188
7.2.2 Multi-layer Insulation.....	190
7.2.3 Thermal Straps .....	190
7.2.4 Thermal Contact Conductance and Bolted Joint Conductance .....	192
7.2.5 Thermal Interface Materials and Conductive Gaskets .....	193
7.2.6 Sunshields.....	194
7.2.7 Thermal Louvers.....	194
7.2.8 Deployable Radiators .....	194
7.2.9 Heat Pipes .....	196
7.2.10 Phase Change Materials/ Thermal Storage Units.....	197
7.2.11 Thermal Switches .....	198
7.2.12 Multifunctional Thermal Structures .....	198
7.3 State-of-the-Art – Active Systems .....	198
7.3.1 Heaters .....	199
7.3.2 Cryocoolers .....	199
7.3.3 Thermoelectric Coolers (TEC).....	202
7.3.4 Fluid Loops .....	202
7.3.5 Active Thermal Architecture.....	202
7.4 Summary.....	203
7.5 References.....	204



## Chapter Glossary

(APG)	Annealed Pyrolytic Graphite
(ARC)	Ames Research Center
(ATA)	Active Thermal Architecture
(BIRD)	Bi-Spectral Infrared Detection
(CSE, USU)	Center for Space Engineering at Utah State University
(ESPA)	EELV Secondary Payload Adapter
(FEP)	Fluorinated Ethylene Propylene
(FETS)	Folding Elastic Thermal Surface
(FOX)	Flat-Plate Heat Pipe On-Orbit Experiment
(GFTS)	Graphite Fiber Thermal Straps
(GSFC)	Goddard Space Flight Center
(HEC)	High Efficiency Cooler
(IR)	Infrared
(ISS)	International Space Station
(KGS)	Kaneka Graphite Sheets
(LPT)	Linear Pulse Tube
(MLI)	Multi-Layer Insulation
(MPFL)	Mechanically Pumped Fluid Loop
(MWIR)	Midwave Infrared
(NLAS)	Nanosatellite Launch Adapter System
(OHP)	Oscillating Heat Pipe
(P-POD)	Poly-Picosatellite Orbital Deployer
(PFL)	Pumped Fluid Loop
(PGF)	Pyrovo Pyrolytic Graphite Film
(PGS)	Pyrolytic Graphite Sheets
(PRISM)	Portable Remote Imaging Spectrometer
( $q_{\text{albedo}}$ )	Solar heating reflected by the planet
( $Q_{\text{gen}}$ )	Heat generated by the spacecraft
( $Q_{\text{out,rad}}$ )	Heat emitted via radiation
( $q_{\text{planetshine}}$ )	IR heating from the planet
( $q_{\text{solar}}$ )	Solar heating
( $Q_{\text{stored}}$ )	Heat stored by the spacecraft
(SDL)	Space Dynamics Laboratory



(SI)	International System of Units
(SPOT)	Standard Passive Orbital Thermal-Control
(SST)	Small Satellite Technology
(TAFTS)	Two Arm Flexible Thermal Strap
(TEC)	Thermoelectric Coolers
(TMT)	Thermal Management Technologies
(TRL)	Technology Readiness Level
(TSU)	Thermal Storage Unit
(UAM)	Ultrasonic additive manufacturing
(ULP)	Ultra-Low Power
(VDA)	Vacuum Deposited Aluminum

## 7.0 Thermal Control

### 7.1 Introduction

All spacecraft components have a range of allowable temperatures that must be maintained to meet survival and operational requirements during all mission phases. Spacecraft temperatures are determined by how much heat is absorbed, stored, or dissipated by the spacecraft. Figure 7.1 shows a simplified overview of heat exchange from a satellite orbiting Earth, but the heating principles apply to any planet or body a spacecraft orbits.

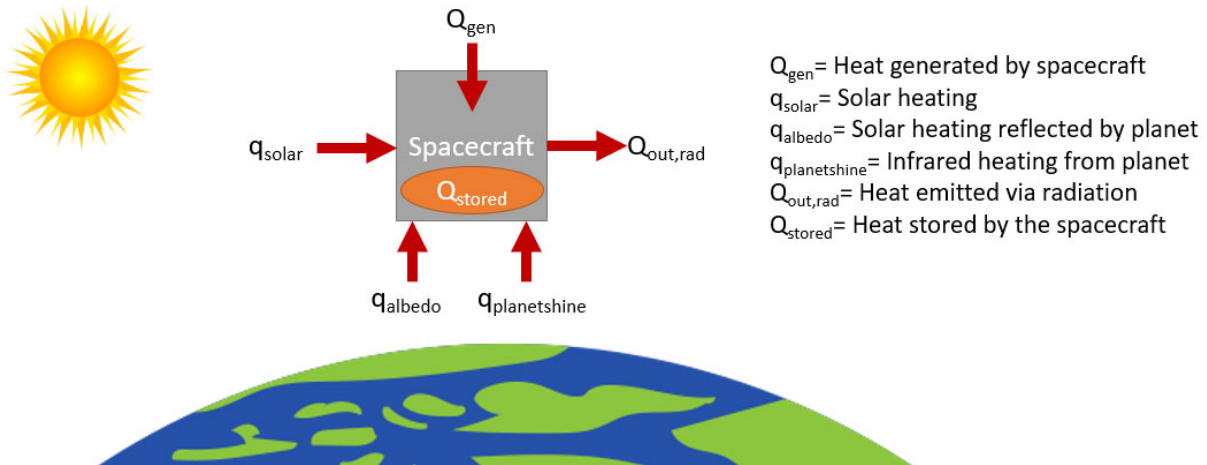
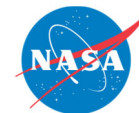


Figure 7.1: Orbiting spacecraft heating simplified overview.  $Q_{gen}$ ,  $Q_{out,rad}$ , and  $Q_{stored}$  are represented as heat values, Watts per square meter in International System of Units (SI), whereas  $q_{solar}$ ,  $q_{albedo}$ , and  $q_{planetshine}$  are represented as heat fluxes. Credit: NASA.

The heat exchange depends on several factors listed below. Solar absorptivity and infrared (IR) emissivity are surface optical properties referenced below and are described further in section 7.2.1: Paints, Coatings, and Tapes. Thermal control of a spacecraft is achieved by balancing the energy as shown in Equation 1.

$$q_{solar} + q_{albedo} + q_{planetshine} + Q_{gen} = Q_{stored} + Q_{out,rad} \quad (1)$$

- $Q_{gen}$  (heat generated by the spacecraft) depends on the power dissipation of spacecraft components.
- The amount of  $q_{solar}$  (solar heating) absorbed by the spacecraft depends on the solar flux, which is determined by distance to the sun, the surface area viewing the sun (view factor), and the solar absorptivity of that surface.
- The amount of  $q_{albedo}$  (solar heating reflected by the planet) absorbed by the spacecraft depends on the planet, the surface area viewing the planet (view factor), and the solar absorptivity of that surface.
- The amount of  $q_{planetshine}$  (IR heating from the planet) absorbed by the spacecraft depends on the planet, the surface area viewing the planet (view factor), and the IR emissivity of that surface.
- $Q_{out,rad}$  (heat emitted via radiation) includes the surface area designated as radiator space, the IR emissivity of the surface, and the difference in temperature between the spacecraft radiator and the heat sink to which it is dissipating, typically and most effectively deep



space.  $Q_{out,rad}$  also include heat lost through insulation or other surfaces not specifically intended to function as radiators.

- $Q_{stored}$  (heat stored by the spacecraft), is based on the thermal capacitance of the spacecraft.

Temperatures are regulated with passive and/or active thermal management technology and design methods. Many of the same thermal management methods used on larger spacecraft are also applicable to SmallSats and given the increased interest in small spacecraft over the last decade, some spacecraft thermal control technologies have been miniaturized or otherwise adapted to apply to SmallSats. Thermal control methods and technologies as applied to large spacecraft are considered state-of-the-art for the purposes of this review but may have a Technology Readiness Level (TRL) value less than 9 for small spacecraft applications.

Challenges of designing a thermal control system for a SmallSat stem from several intrinsic properties, summarized in Table 7-1. Due to the small size and volume limitations inside the deployer or around deployables, there is often no room for multi-layer insulation (MLI) for CubeSats. The thermal solution must be worked out as a coatings problem, exposing the CubeSat to more transient thermal behaviors.

<b>SmallSat Property</b>	<b>Challenge</b>
Low thermal mass	The spacecraft is more reactive to changing thermal environments.
Limited external surface area	There is less real estate to be allocated to solar cells, designated radiator area, and/or viewports required for science instruments.
Limited volume	There is less space for electronic components, science instruments, and thermal control hardware. Components can be more thermally coupled and it can be harder to isolate different thermal zones.
Limited power	There is less power available for powered thermal control technology.
Power Density	There is a big challenge to dissipate power as electronics are stacked close to each other, sometimes with no direct path to radiator.
MLI Edge Effects	MLI can “short” along the edges resulting in degraded performance, not specific to SmallSats; more of a general spacecraft issue.

The information described in this section is not exhaustive but provides an overview of current state-of-the-art thermal technologies and their development. TRL designations may vary with changes specific to the payload, mission requirements, reliability considerations, and/or the environment in which performance was demonstrated. Readers are highly encouraged to reach out to companies for further information regarding the performance and TRL of described technology. There is no intention of mentioning certain companies and omitting others based on their technologies or relationship with NASA.

## **7.2 State-of-the-Art – Passive Systems**

Passive thermal control maintains component temperatures without using powered equipment. Passive systems are typically associated with low cost, volume, weight, and risk, and are advantageous to spacecraft with limited, mass, volume, and power, like SmallSats and especially CubeSats. MLI, coatings/surface finishes, interface conductance, heat pipes, sunshades, thermal straps, interface materials, and louvers are some examples of passive thermal control technology.



In addition to passive thermal control technology, structural and electrical design methods also contribute to managing the thermal environment, passively. These design methods include:

- Material selection
  - Structural component materials chosen based on needed heat transfer through the structure. A high or low thermal conductivity may be more advantageous based on the application.
- Spacecraft orientation
  - If orientation is not dictated by science objectives, changing the orientation of the spacecraft can help maintain temperatures.
  - Changing orientation may only be needed during certain mission phases, such as science operation if larger amounts of heat are dissipated.
  - This method is often used in conjunction with other thermal control methods, such as orienting the spacecraft so that the radiator area can face deep space.
- Thermal interfaces:
  - Definition of the thermal contact between components through specific mounting methods can thermally isolate components or allow more heat to be transferred to a structural element (or radiator area) when each is needed. For example:
    - Heat transfer can be reduced by mounting a component through multiple stacked washers with low thermal conductivity.
    - Heat transfer can be increased by mounting components with more fasteners (if applicable) and can be further increased by using thermal interface materials between a component and mounting surface.
- Circuit board design considerations, include:
  - Copper layers within each board can be increased, in number or thickness, to conduct heat away from electrical components through the boards to their structural connection points.
  - Circuit boards can be mounted to increase heat transfer away from the boards to the structure, such as by mounting with wedge locks.

Table 7-2 is a list of current passive thermal control technology as applied to SmallSats. One key factor to consider when choosing thermal control technology, both passive and active, is the temperature limits of the technology itself. The goal is to use the appropriate technology to maintain the temperatures of spacecraft components within their limits, but the technology used to achieve this also has limits. It is recommended to verify that the technology used is applicable to the given design not only with respect to needed function, but to the environment (temperature limits) as well.

<b>Table 7-2: Passive Thermal Technology</b>		
<b>Manufacturer</b>	<b>Product</b>	<b>TRL in LEO Environments</b>
AZ Technology, MAP, Astral Technology Unlimited, Inc., Dunmore Aerospace, AkzoNobel Aerospace Coatings, Parker-Lord, Medtherm	Paint and Coatings	7-9
Sheldahl, Dunmore, Aerospace Fabrication & Materials, 3M	Tapes	7-9
Sheldahl, Dunmore, Aerospace Fabrication & Materials	MLI Materials	7-9



NASA GSFC, Aerothreads, Aerospace Fabrication & Materials	MLI Blanket Fabrication	7-9
Space Dynamics Laboratory, Thermal Management Technologies, Boyd Corp., Technology Applications, Inc., Thermotive Technology, Redwire Space	Thermal Straps	7-9
Bergquist, Parker Chomerics, Aerospace Fabrication & Materials, AIM Products LLC, Intermark USA, Indium Corporation, Dow Corning, NeoGraf, Laird Technologies, Avantor (NuSil)	Thermal Interface Materials and Conductive Gaskets	7-9
Sierra Lobo, Aerospace Fabrication and Materials	Sun Shields	4 – 7
NASA Goddard Space Flight Center (GSFC)	Thermal Louvers	7-9
Aerospace Fabrication and Materials, Thermal Management Technologies, Redwire Space	Deployable Radiators	5-6
Aavid Thermacore, Inc., Advanced Cooling Technology, Inc., Redwire Space	Heat Pipes	7-9
Thermal Management Technologies, Active Space Technologies, Advanced Cooling Technology, Inc., Redwire Space	Phase Change Materials/ Thermal Storage Units	7-9
Starsys, Redwire Space	Thermal switches	7-9
Thermal Management Technologies	Multifunctional Thermal Structures	4-5

### 7.2.1 Paints, Coatings, and Tapes

In a vacuum, heat is transferred only by radiation and conduction, with no convection. The internal environment of a fully enclosed small satellite is usually dominated by conductive heat transfer, while heat transfer to/from the outside environment is driven via thermal radiation. Many missions with electrical surface resistivity requirements drive the use of coatings with these properties to handle these surface charging concerns (this also applies to MLI). For SmallSat missions where extensive use of MLI is not practical, a mixed use of several different coatings is needed to achieve optimal energy balance and thermal performance. There are also coatings that better approximate the use of MLI by being relatively low emissivity (such as 0.25) with a lower alpha (0.1) so they don't overheat in the sun. These are colloquially known as tailorable emittance coatings that involve some oxide depositions starting with a vacuum deposited aluminum (VDA) base to drive up the emissivity while keeping the alpha low.

The thermal radiation band of the electromagnetic spectrum is between 0.1 and 100  $\mu\text{m}$  in wavelength, as shown in Figure 7.2. Outside of the thermal radiation waveband, electromagnetic energy generally passes through objects or has very little heat energy under practical conditions. Thermal analyses are typically conducted using a two waveband absorptance model which subdivides the thermal energy spectrum into solar ( $< 3 \mu\text{m}$ ) and IR ( $> 3 \mu\text{m}$ ) wavelengths.



Thermal radiation heat transfer is controlled by using materials that have specific optical surface properties, namely: solar absorptivity and IR emissivity. Solar absorptivity governs how much incident heating from solar radiation a spacecraft absorbs, while IR emissivity determines how much heat a spacecraft emits to space, relative to a perfect blackbody emitter, and what fraction of thermal radiation from IR sources (e.g., the Earth, Moon, any particularly hot spacecraft components) are absorbed by that spacecraft surface.

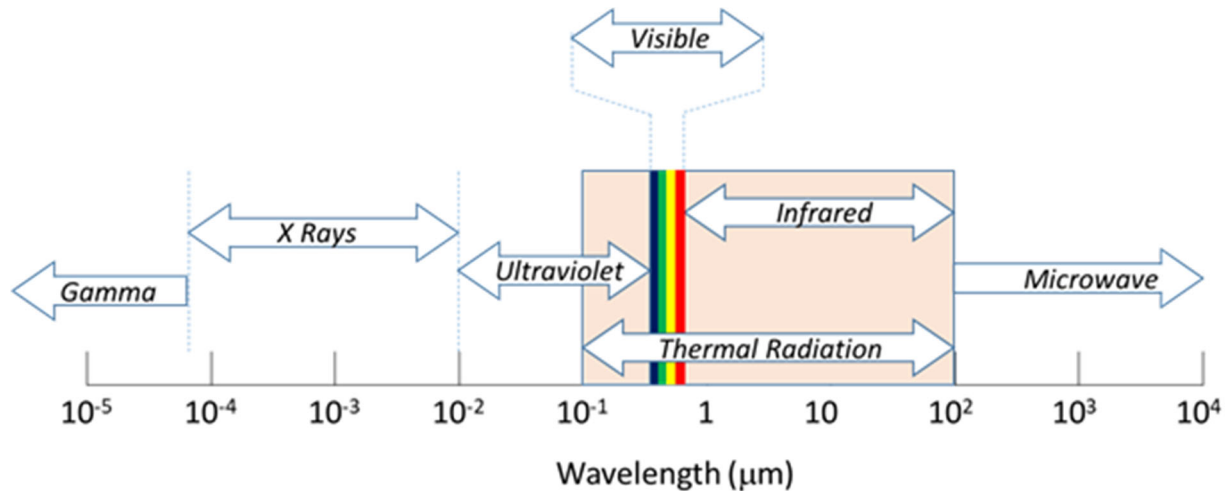


Figure 7.2: Electromagnetic spectrum showing the range of Thermal Radiation. Credit: NASA.

The surface properties of a spacecraft can be modified by adding specialized paints, coatings, surface finishes, or adhesive tapes, depending on the needs of the spacecraft. For example, matte black paint has a high solar absorptivity and high IR emissivity for surfaces required to absorb a high percentage of solar heating and emit a high percentage of spacecraft heat. Alternatively, matte white paint has a low solar absorptivity and high IR emissivity (1) for surfaces required to absorb a low percentage of solar heating and emit a high percentage of spacecraft heat (e.g., radiator). Second-surface silver Fluorinated Ethylene Propylene (FEP) tapes offer excellent performance as radiator coatings, reflecting incident solar energy (low solar absorptivity) while simultaneously emitting spacecraft thermal energy efficiently (high IR emissivity). The selection between paints, coatings, and tapes depends on the application. Tape is typically easy to apply and remove, is comparatively inexpensive, and has a longer usable lifetime than paint. Tape can also be added later in the assembly process if changes to thermal control need to be made after the spacecraft has already begun assembly. Some tapes, however, must be handled carefully to maintain optical properties and can be difficult to bond properly to curved surfaces. Coatings and paints must often be applied earlier in the assembly process but can cover non-flat surfaces more easily. However some paints, like Parker-Lord's Aeroglaze 306/307, are expensive and require extensive and highly specialized processes to apply. Different options may also have different temperature limits. All these factors must be considered with regard to the needed application when selecting the final solution.

AZ Technology, MAP, Astral Technology Unlimited, Inc., Parker-Lord, Inc., Sheldahl, and AkzoNobel Aerospace Coatings manufacture thermal paint, coatings, and tapes for aerospace use that have been demonstrated on multiple small spacecraft missions. Most manufacturers have catalogs and/or guidebooks that provide detailed product information, including optical properties, and application guidance (for example, Sheldahl provides "The Red Book," (2)) to aid design selection.

One example, BioSentinel, a 6U spacecraft in development at NASA Ames Research Center (ARC) that is currently slated to be launched as a secondary payload on the Artemis I mission





(2022), makes extensive use of Sheldahl metallized tape coatings and second-surface silvered FEP tapes to control its external thermal radiative properties and overall energy balance (4). Another example, Picard, a 150 kg SmallSat, used white paint on the Sun pointing face to reduce the amount of solar flux absorbed and lower temperatures. For most small spacecraft projects to date, adhesive tapes, such as silver FEP, or other standard surface finishes (e.g., polishing, anodize, alodine) have been the preferred choices.

### **7.2.2 Multi-layer Insulation**

A MLI blanket is typically comprised of multiple inner layers of a thin material with low IR emissivity (usually 10 to 20 layers) and a durable outer layer. The amount of radiative heat transfer allowed is limited by the many layers of reflectors. The low IR emissivity layers are either embossed or alternated with thin netting to limit conduction through the layers. Perforations may be added to allow the MLI to vent trapped gas once arriving on-orbit, although this can also be achieved via edge venting. MLI is used as a thermal radiation barrier to both protect spacecraft from incoming solar and IR flux, and to prevent undesired radiative heat dissipation to space. It is commonly used to maintain temperature ranges for components in-orbit.

MLI is delicate and performance drops drastically if compressed (causing a thermally conductive “short circuit”), so it should be used with caution or avoided altogether on the exterior of small satellites that fit into a deployer (e.g., P-POD, NLAS). MLI blankets can also pose a potential snagging hazard in these tight-fitting, pusher-spring style deployers. Additionally, MLI blankets tend to drop efficiency as size decreases because heat transfer through the blanket increases closer to the blanket edges, and the specific attachment method has a large impact on performance because attachment to the spacecraft creates a heat path.

Due to these challenges, MLI generally does not perform as well on small spacecraft (more specifically CubeSat form factors) as on larger spacecraft. Surface coatings are typically less delicate and more appropriate for the exterior of a small spacecraft that will be deployed from a dispenser. Internal MLI blankets that do not receive direct solar thermal radiation can often be replaced by a variety of low emissivity tapes or coatings that perform equally well in that context, using less volume and at a potentially lower cost.

Dunmore Aerospace provides an option for CubeSat developers to make their own MLI blanket with Satkit (3). Satkit provides Dunmore’s STARcrest MLI materials cut into manageable sizes, including a roll of outer layer material, a larger roll of inner layer material, and polyimide tapes for assembly and edge binding. The materials included in the kit have been flown in spaceflight applications before, but Satkit is currently TRL 6. Dunmore also offers polyimide film tape and MLI tape designed to insulate wires and cables on SmallSats and is TRL 7.

### **7.2.3 Thermal Straps**

A thermal strap is a flexible, thermally conductive link added between a heat source and sink to conductively transfer heat. They are often used between high heat dissipating chips or components and a chassis wall or other radiator surface. Their flexibility prevents the addition of structural loads. Thermal straps can be made metal, traditionally copper or aluminum, or high conductivity carbon materials, such as graphite. They can be formed of multiple foil sheets or wound cables (also referred to as ropes and braids), with end blocks at each end to hold the sheets/cables in place and to mount or otherwise attach to the needed surfaces. Straps with more than two end blocks and multiple material combinations can also be produced and have been used on large spacecraft.

There are multiple companies that manufacture thermal straps for spaceflight. For example, Thermal Management Technologies manufactures standard flexible thermal straps in aluminum and copper foil layers or copper braids as shown in figure 7.3 (4). Custom thermal straps are also

commonly fabricated and tested. Space Dynamics Laboratory (SDL) has pioneered solderless flexible thermal straps that contain no solder, epoxy, or other filler materials to maximize thermal performance. Figure shows a comparison of the as-tested conductance for the same strap geometry fabricated with three different foil materials of aluminum, copper, and pyrolytic graphite sheets (PGS). SDL supplied Utah State University with a PGS strap for the Active Thermal Architecture (ATA) project sponsored by the Small Spacecraft Technology (SST) program. A follow-on to this ATA project is referenced in the cryocooler section.



Advances in thermal straps are being developed to further increase heat transfer capability. Aavid Thermacore, Boyd Corporation's thermal division, has designed thermal straps using their patented k-core technology that has an annealed pyrolytic graphite (APG) core within an encapsulating structure. These have greater conduction efficiency compared to traditional aluminum straps as the k-Core increases the overall thermal conductivity (5). This technology has been fully designed and tested and is TRL 5 for small spacecraft application.

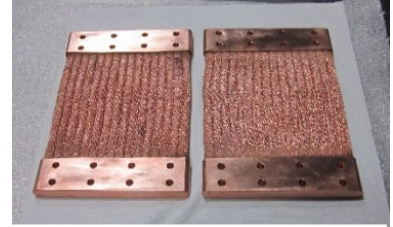


Figure 7.3: Flexible Thermal Straps. Credit: Thermal Management Technologies.

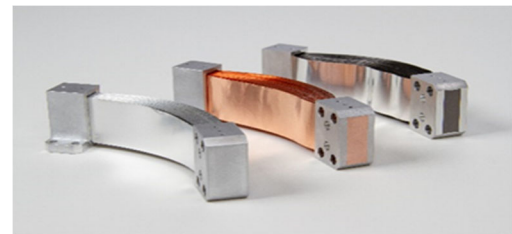
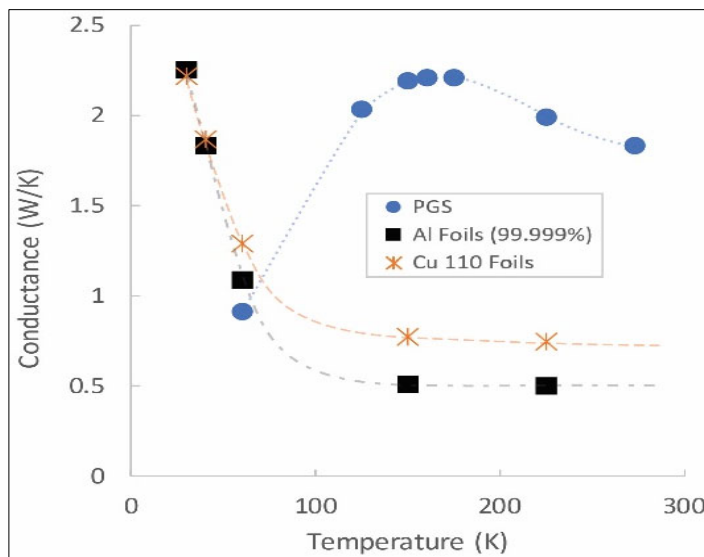


Figure 7.4: Thermal strap design with aluminum foils, copper foils, and PGS in aluminum end blocks (above), and their respective measured thermal conductance (left). The dashed lines connecting data points are based on material thermal conductivity curves. Credit: SDL.

Technology Applications, Inc. has specialized in testing and developing Graphite Fiber Thermal Straps (GFTS), with flight heritage on larger spacecraft missions (Orion and Spice). GFTS, shown in figure 7.5, are extremely lightweight and highly efficient and thermally conductive with unmatched vibration attenuation (6). While this technology has not been demonstrated on a small spacecraft, the fittings can only be made so small and most of the straps fall into a very typical size range with the end fitting thickness at a minimum of 0.10 – 0.30 in, with a thinner flexible section.



Figure 7.5: Graphite Fiber Thermal Straps (GFTS). Credit: Technology Applications, Inc.

Thermotive Technology developed the Two Arm Flexible Thermal Strap (TAFTS) that is currently flying on JPL's Portable Remote Imaging Spectrometer (PRISM) instrument. Space infrared cameras require extremely flexible direct cooling of mechanically sensitive focal



planes. The design of TAFTS uses three swaged terminals and a twisted section that allows for significant enhanced elastic movement and elastic displacements in three planes, while a more conventional strap of the same conductance offers less flexibility and asymmetrical elasticity (7). While infrared cameras have flown on small spacecraft missions, the TAFTS design has not been employed on a SmallSat.

The Pyrovo Pyrolytic Graphite Film (PGF) thermal straps developed by Thermotive have already flown in optical cooling applications for high altitude cameras and avionics on larger spacecraft. The specific thermal conductivity of this material has been shown to be 10x better than aluminum and 20x better than copper, as seen in figure 7.6 (8). These straps flew on JPL’s ASTERIA CubeSat in 2017 and were used on the Mars 2020 rover mission.

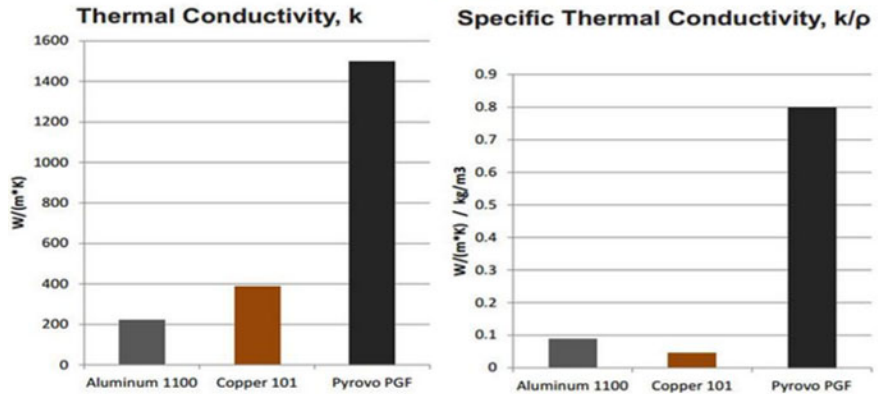


Figure 7.6: Pyrovo PGF Material Comparison. Credit: Thermotive Technology.

Redwire Space offers flexible thermal strap solutions that use high-k graphite material, such as their Q-Strap shown in figure 7.7. By layering sheets of graphite material into a traditional layered heat strap, the heat transfer is increased while the mass of the strap system is decreased. For the same conductance, fewer layers can be used compared to traditional aluminum or copper thermal straps, minimizing mass and volume. The Q-Strap can be manufactured in various lengths and widths, has an in-plane thermal conductivity of ~700 W/m-K and is anywhere from 1.4 to 3.5 kg/m<sup>2</sup>.

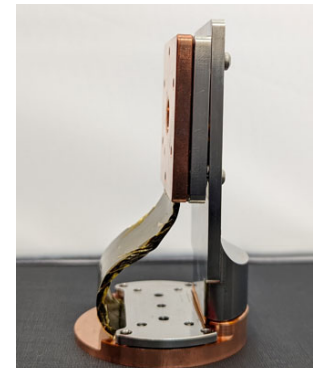


Figure 7.7: Redwire’s Q-Strap. Credit: Redwire Space.

**7.2.4 Thermal Contact Conductance and Bolted Joint Conductance**

Two surfaces which are pressed together by uniform pressure will transfer heat via “contact” conductance. This conductance value is a product of the heat transfer coefficient and the contact surface area. The heat transfer between such interfaces can be varied by using interface filler materials and conductive gaskets (9).

Bolted joints experience non-uniform pressure creating a more complex heat transfer scenario. The conductance will depend on screw size, torque, surface properties and other values. The conductance can be varied by changing torque, surface properties and finishes and materials. Table 7-3 provides conductances for various screws (9).

Table 7-3: Bolted Joint Thermal Conductance Design Guideline		
	Conductances [W/K]	
Screw Size	Small Stiff Surface	Large Thin Surfaces
2-56	0.21	0.105

4-40	0.26	0.132
6-32	0.42	0.176
8-32	0.80	0.264
10-32	1.32	0.527
1/4-28	3.51	1.054

### 7.2.5 Thermal Interface Materials and Conductive Gaskets

Thermal interface materials are inserted between two components to increase the conductive heat transfer between them. They are often made as a sheet or pad of material to be sandwiched between surfaces, but there are many different types that vary in material, thickness, thermal conductivity, temperature limits, and vacuum-compatibility. Thermal interface materials can also be a grease or paste.

Thinner sheets of materials are commonly used between heat dissipating electronics boxes and mounting surfaces to thermally sink the hot components to a colder surface and reduce the temperature of the electronics. The performance of these types of materials depends on reaching a certain contact pressure between components to ensure the needed heat transfer. Laird Performance Materials has developed many different types of thermal interface materials for a variety of applications. For example, their Tflex series, shown in figure 7.8, is about 1 to 5 mm thick with a thermal conductivity of  $6 \text{ W mK}^{-1}$  (10), whereas their Tgon series of materials are about 0.13 to 0.5 mm thick with a thermal conductivity of  $5 \text{ W mK}^{-1}$  (11).

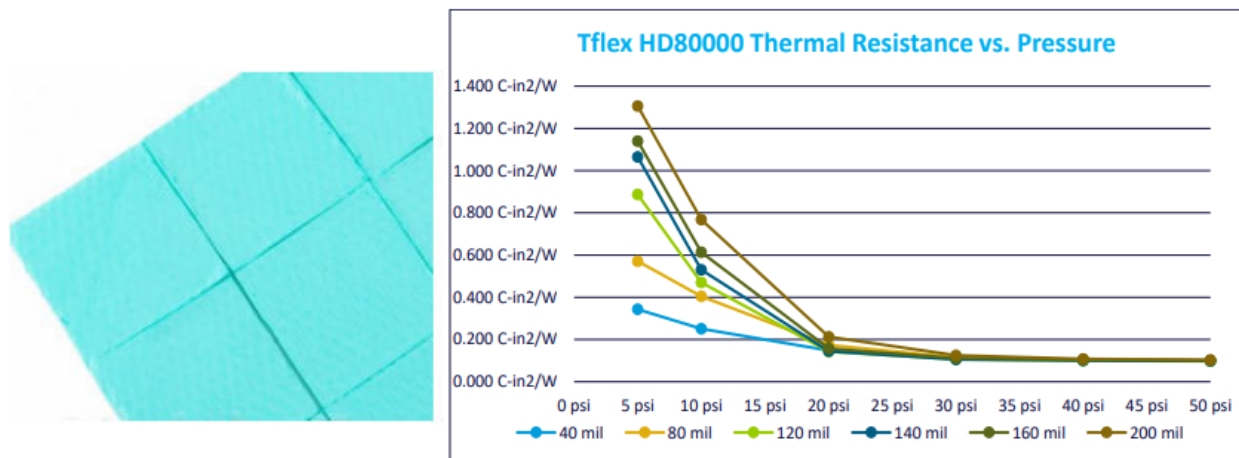


Figure 7.8: Laird Tflex HD80000 series sheets (left) and Thermal Resistance vs. Pressure (right). Credit: Laird Performance Materials.

Thicker pad-like materials, such as Henkel brand GAP PADS®, are often used between high heat dissipating chips on an electronics boards and the electronics enclosure. These are also made to fit a variety of applications, with varying material, thickness, conformability, tear-resistance, electrical isolation, thermal conductivity, and more (12). Several additional thermal interface materials developed by Henkel Corporation are shown in figure 7.9.

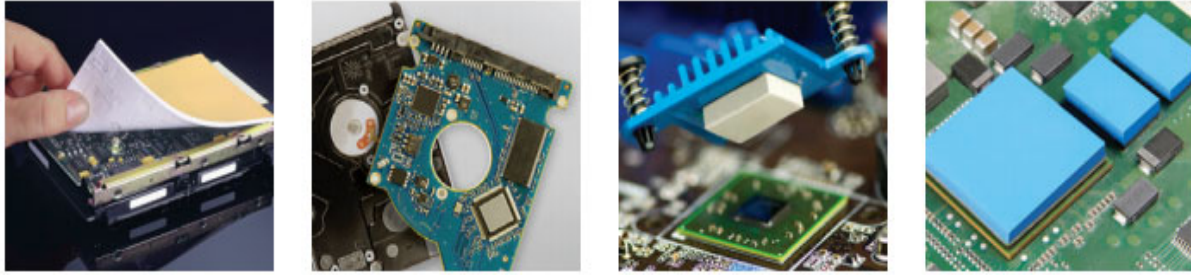


Figure 7.9: A variety of thermal interface materials. Credit: Henkel Corporation.

### 7.2.6 Sunshields

A sunshield, or sunshade, is an often-deployed device made up of a material with low solar absorptivity that reduces the amount of incident solar flux impinging a spacecraft, by blocking the view to the sun. Sunshields are commonly used for spacecraft thermal control, although only recently on small spacecraft. Sierra Lobo developed a deployable sunshield that flew on CryoCube-1, shown in figure 7.10, which was launched on Dragon CRS-19 in February 2020. In low-Earth orbit, this sunshield can support a multiple month-long duration lifetime and can provide temperatures below 100 K and below 30 K with additional cooling (13).

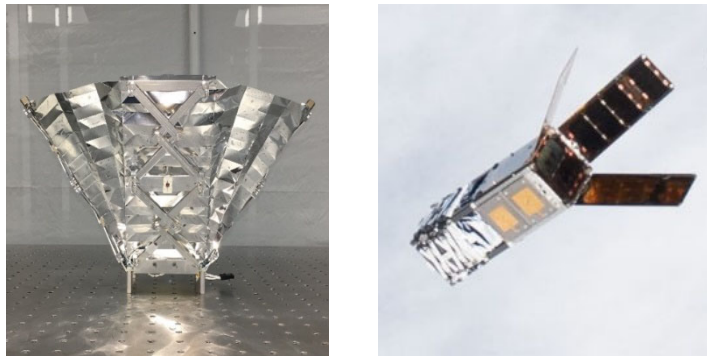


Figure 7.10: Deployed Sunshield on CryoCube-1 (left) and CryoCube-1 in orbit with shield stowed (right). Credits: Sierra Lobo (left) and NASA (right).

### 7.2.7 Thermal Louvers

Thermal louvers are thermally activated shutters that regulate how much heat the louvered surface can dissipate. As the louvers open, the average IR emissivity of the surface changes, changing how much heat the surface dissipates. Full-sized louvers on larger spacecraft have high efficacy for thermal control, however, integration on small spacecraft is challenging. Typical spacecraft louvers are associated with a larger mass and input power, which are both limited on small spacecraft.

Although commonly defined as active thermal control, here we consider louvers as a passive thermal control component because the CubeSat-adapted design considered does not require a power input from the spacecraft. NASA GSFC developed a passive thermal louver that used bimetallic springs to control the position of a single flap so when the temperature of the spacecraft rises, the springs expand and open the louver to modify the average IR emissivity of the exterior surface. This louver was developed as a technology demonstration on a 6U CubeSat, Dellinger, which was released from the International Space Station (ISS) into low-Earth orbit in late 2017 (14), however performed no actual thermal control function on the CubeSat.

### 7.2.8 Deployable Radiators

A radiator is a dedicated surface for dissipating excess heat via radiative heat transfer and has a high IR emissivity and low solar absorptivity, an optical property combination typically referred to as “radiator properties.” A deployable radiator is stowed during transit or when the radiator is not needed and deployed when excess heat dissipation is required. Deployable radiators on small

spacecraft can be challenging due to volumetric constraints. While paint has been widely used to create efficient radiator surfaces on larger spacecraft, the relatively limited available external surface area on SmallSats that already have body-mounted solar cells reduces the potential for creating dedicated radiative surfaces. For a system that requires a large amount of heat dissipation, a passive deployable radiator would greatly enhance thermal performance by increasing the available radiative surface area. Since deployable radiators may be needed because of a lack of radiator surfaces on the spacecraft body due to body-mounted solar cells, an alternate approach (perhaps more common for CubeSats) is to use the chassis body as the radiator area and have a deployable solar array. Also, deployed solar arrays would be able to radiate off a high emissivity/low solar absorptance backside for improved thermal management of the array. There has been steady development in this technology over the last five years and radiator designs for SmallSats have improved to TRL 5.

Thermal Management Technologies has developed thermally efficient deployable radiators for small spacecraft that integrate a radiator surface with a high-conductance hinge. The thermally conductive hinge causes minimal temperature gradients between the radiator and spacecraft; thus, the radiator can operate near spacecraft temperatures. Figure 7.11 shows the radiator design. The radiating surface uses graphite composite material for mass reduction and increased stiffness, where the typical radiator uniformity is less than  $0.1^{\circ}\text{C W}^{-1}\text{ m}^{-1}$ . This technology is currently in the development and testing phase (15).

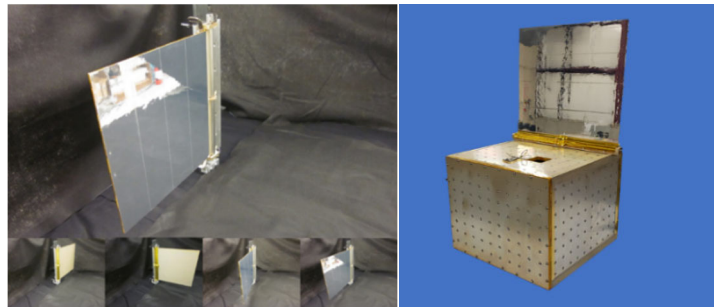


Figure 7.11: 100W deployable radiator (left), and radiator shown on ESPA structure (right). Credit: Thermal Management Technologies.

Thermotive is researching the Folding Elastic Thermal Surface (FETS), a deployable passive radiator for hosted payload instruments and CubeSats. Originally conceived as a thermal shield and cover for a passive cooler (cryogenic radiator) on JPL's MATMOS mission, this proposed concept is being modified as a deployable radiator for small spacecraft (16).

The Q-Rad deployable radiator offered by Redwire Space leverages a lightweight high-strain composite-based deployment approach and incorporates flexible, high-k graphite material to transport heat effectively across the hinge line, making it a lightweight and modular solution. For a 20 cm length radiator prototype, an estimated 300 W/m could be rejected with a rejection temperature of  $100^{\circ}\text{C}$  based on the 80% fin efficiency. Figure 7.12 shows one example of a deployable thermal dissipation technology.

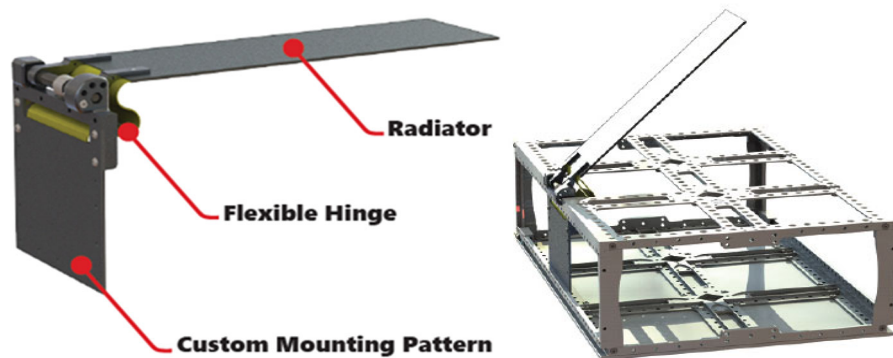


Figure 7.12: Q-Rad Deployable Radiator technology. Credit: Redwire Space.

A novel deployable radiator is being developed by JPL, California Polytechnic San Luis Obispo, and California State Los Angeles. At the core of this technology is an Additively Manufactured Deployable Radiator with embedded Oscillating Heat Pipes (AMDROHP) that enables heat to be efficiently transported across moving interfaces. The current AMDROHP radiator design is shown in figure 7.13 and consists of an evaporator and a condenser plate, and a series of flexible joints connecting the two plates. AMDROHP can be stowed within a 3U CubeSat and can be passively deployed without use of an actuator. This AMDROHP technology is currently in the testing phase and further design optimization is ongoing. This project is funded by NASA's SST program in the 2020 cohort of the SmallSat Technology Partnerships initiative.

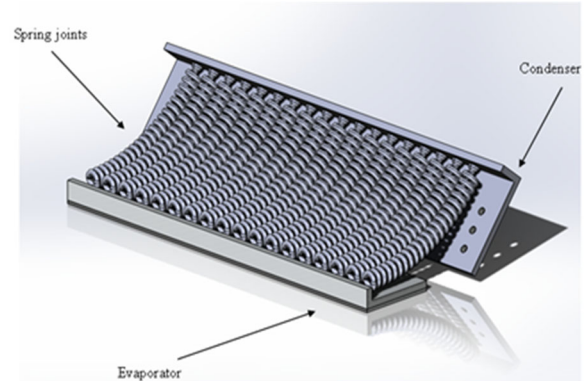


Figure 7.13: Rendering of an AMDROHP radiator design. Credits: California State Los Angeles, Jet Propulsion Laboratory, and California Polytechnic San Luis Obispo.

### 7.2.9 Heat Pipes

A traditional heat pipe is a passive device comprised of a metal container (pipe) that holds a liquid under pressure and has a porous wick-like structure within the container. When heat is applied to one end of the tube, the liquid inside the tube near the hot end vaporizes into a gas that moves through the tube to the cooler end, where it condenses back into a liquid. The wick transports the condensed liquid back to the hot end via capillary action. There are also more complicated and non-passive types of heat pipes such as variable conductance, diode, and loop heat pipes, which are not further explained in this document.

Heat pipes are an efficient passive thermal transfer technology, where a closed-loop system transports excess heat via temperature gradients, typically from electrical devices to a colder surface, which is often either a radiator itself, or a heat sink that is thermally coupled to a radiator. Traditional constant conductance heat pipes are cylindrical in shape with a grooved inner wick, like those used on Bi-Spectral Infrared Detection (BIRD), a 92 kg satellite launched in 2001, to join satellite segments (17), see figure 7.14. Heat pipes can also be configured as flat plates with tubing sandwiched between two plates and charged with a working fluid inside. SDS-4, a 50 kg small spacecraft launched in 2012, incorporated the Flat-Plate Heat Pipe On-Orbit Experiment (FOX), developed at JAXA (18).

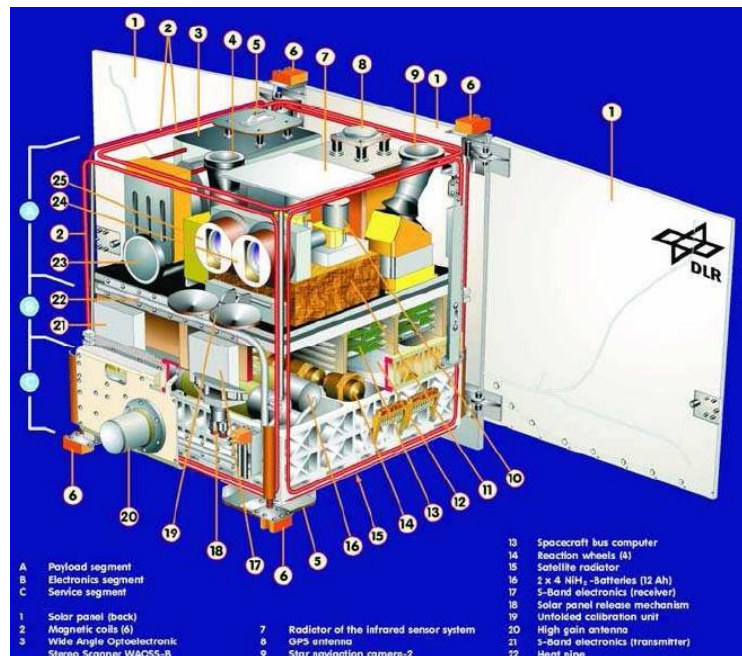
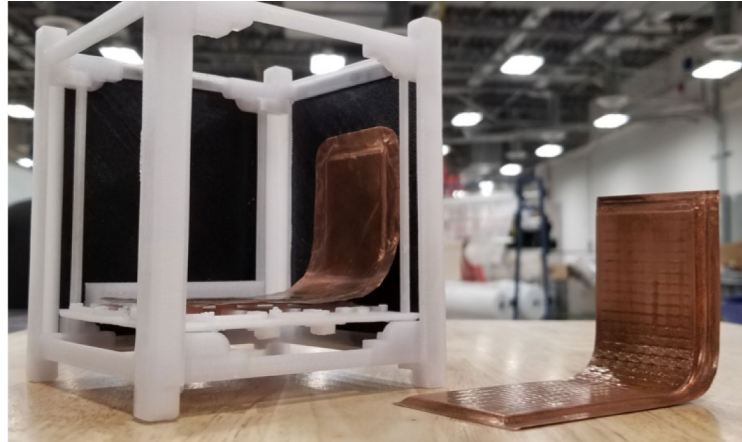


Figure 7.14: Diagram of BIRD, heat pipe denoted by #22. Credit: DLR-OS (DLR Institute of Optical Sensor Systems).

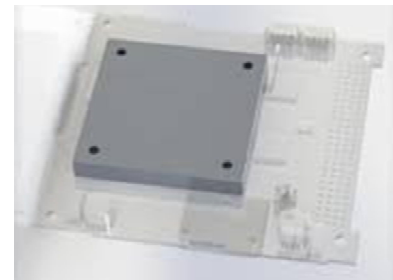
Redwire Space has multiple forms of heat pipe thermal transport solutions to provide relatively high heat load transport with high heat acquisition across a satellite's architecture including flat heat pipes and oscillating heat pipes. The FlexCool is a bent, flat heat pipe developed as a cross between a heat pipe and a thermal strap that can be customized for higher heat fluxes by increasing the thickness. It has ten times the thermal conductivity of copper, while being 90% lighter, and up to  $6 \text{ W/cm}^2$  at 1 mm thick. The FlexCool heat pipe flew on TechEdSat-10, a 6U CubeSat deployed from the ISS in 2020, to thermally manage the radio. An image of this technology in a 1U CubeSat model is shown in figure 7.15. Another solution offered by Redwire Space is the Flex-OHP, an oscillating heat pipe (OHP) with thermal transport technology that can accommodate higher heat fluxes as it has a higher effective thermal conductance compared to solid-state solutions, at a total conductance of  $1.7 \text{ W/K}$  at  $50 \text{ }^\circ\text{C}$ .



*Figure 7.15: FlexCool conformable micro heat pipe before integrating with TechEdSat-10 DVB-S2 radio. Credit: Redwire Space.*

### 7.2.10 Phase Change Materials/ Thermal Storage Units

A phase change material used as a thermal storage unit is made up of a material (e.g., wax) within a metal housing. A heat source is attached to the housing so that, as the source conducts heat to the enclosure, the phase change material within absorbs the energy as it changes phase (usually from solid to liquid). Then, as the heat source energy output reduces, the phase change material releases the energy as it changes back to its initial phase (usually from liquid to solid). Owing to the low thermal conductivity of the phase change material, the metal housing must conduct heat into the phase change medium for efficient solidification or melting. Thermal storage units are typically used with components that will experience repeated temperature cycling or to slow down the temperature transient caused by a high heat dissipation event, or a temporary change in the environment such as an eclipse. They can be challenging to apply to CubeSats and other small satellites because of the extra mass of the housing needed.



*Figure 7.16: CubeSat Thermal Storage Unit. Credit: Thermal Management Technologies.*

Thermal Management Technologies has developed a phase-changing thermal storage unit (TSU) that considers desired phase-change temperatures, interfaces, temperature stability, stored energy, and heat removal methodologies, as shown in figure 7.16. This device will allow the user to control temperature peaks, stable temperatures and/or energy storage (19).

Redwire Space has developed multiple phase change materials (PCM)-based thermal energy storage panels that are of the CubeSat form factor, allowing them to be easily stacked in between critical components (20). Q-Store shown in figure 7.17 (left) and Q-Cache shown in figure 7.17 (right) are two examples of thermal energy storage technology solutions. Both Q-Store and Q-Cache are tailorable thermal storage solutions that dampen thermal swings. Either one can be customized to fit complex shapes, and both have thermal vias embedded into their design to assist with the thermal



path challenges inherent to paraffin-wax-based technologies (which have very low thermal conductivities). Q-Store is a brazed technology solution, whereas Q-Cache is an additively manufactured option.

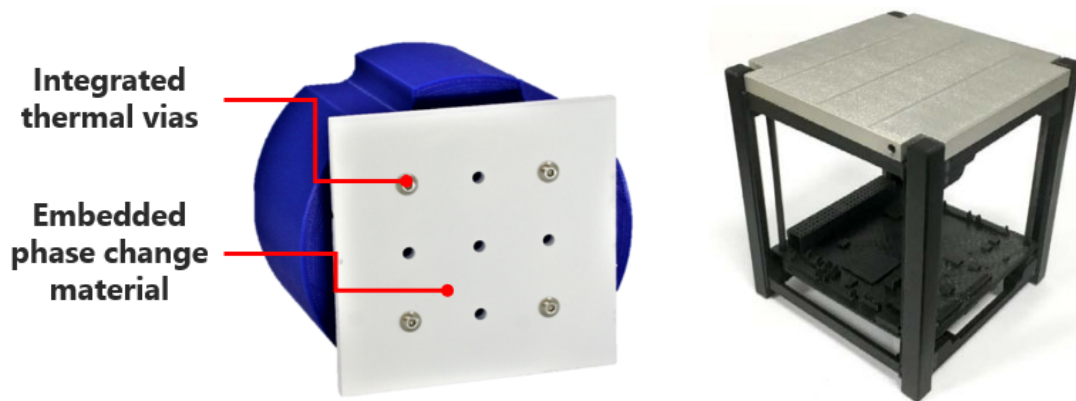


Figure 7.17: Redwire Space's thermal energy storage technologies: (left) Q-Store and (right) Q-Cache. Credit: Redwire Space.

### 7.2.11 Thermal Switches

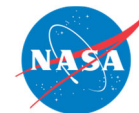
A thermal switch is a device that switches a heat conduction path between either a strong thermal coupling or weak thermal coupling (thermal isolation) as needed to control the temperature of heat producing components. A switch typically connects a heat producing component and a low temperature sink, such as a radiator. Heat switches differ from thermostats in that they passively modulate a thermal coupling while thermostats modulate heater circuits (21). Part of the challenge in integrating a thermal switch in SmallSats is that they take up additional space between a component and heat sink. Typical, heat switches may provide a conduction ratio of 10:1 with a technology goal of 100:1 (22).

### 7.2.12 Multifunctional Thermal Structures

A newer development in passive thermal control for small spacecraft are multi-functional thermal structures. These integrate thermal control capabilities directly into the structure. This is particularly advantageous for small spacecraft due to strict mass and volume constraints. Currently, Thermal Management Technologies has adapted its multifunction heat spreading structure technology, scaled it to smaller satellite configurations, and called it Standard Passive Orbital Thermal-control (SPOT) Structures. SPOT Structures come in four standard configurations: 6U, 12U, Launch U, and ESPA (23). Each incorporates heat-spreading technology that improves the ability to radiate waste heat. They incorporate features such as low mass, high stiffness/strength, and integrated heat pipes. This new technology is at TRL 4.

## 7.3 State-of-the-Art – Active Systems

Active thermal control methods rely on input power for operation and have been shown to be more effective in maintaining tighter temperature control for components with stricter temperature requirements or higher heat loads (24). Typical active thermal devices used on large-scale spacecraft include electrical resistance heaters, cryocoolers, thermoelectric coolers, and fluid loops. Electrical heaters are usually easily integrated into SmallSat architectures as they do not typically use much mass or volume. Heaters are frequently used in all space applications, including small and large satellites, so they are often included as passive thermal control technology. Other active systems are challenging to integrate into CubeSats and other small satellites because of the power, mass, and volume needs associated with each given technology.



Until spacecraft designers can miniaturize existing actively controlled thermal techniques and reduce power requirements or increase available spacecraft power, the use of active thermal systems in small spacecraft will be limited.

Current state-of-the-art active thermal technologies for SmallSats are shown in Table 7-3.

<b>Manufacturer</b>	<b>Products</b>	<b>TRL in LEO Environment</b>
Minco Products, Inc., Birk Manufacturing, All Flex Flexible Circuits, LLC., Fralock, Tayco Engineering, Inc., Omega	Electrical Heaters	7-9
Ricor-USA, Inc., Create, Sunpower Inc., Northrop Grumman, NASA Jet Propulsion Lab, and Lockheed Martin Space Systems Company	Cryocoolers	5-6
Marlow, TE Technology Inc., Laird	Thermoelectric Coolers (TEC)	7-9
Lockheed Martin	Fluid Loops	4-5
NASA Small Spacecraft Technology program	Active Thermal Architecture (ATA)	4-6

### 7.3.1 Heaters

Electrical resistance heaters used on small spacecraft are most often Kapton heaters, which consist of a polyimide film with etched foil circuits that produce heat when a current is applied. Kapton heaters also often have a pressure sensitive adhesive on one side for easy application. Heaters are typically controlled by a thermostat or temperature sensor and used in cold environments to maintain battery temperature, typically the component with the narrowest temperature limits. The low mass of SmallSats requires little additional heater power to maintain temperature limits, and so heaters do not typically need to be very high power to effectively manage temperatures.

The 1U CubeSats Compass-1, MASAT-1, and OUTFI-1 each required an electrical heater attached to the battery in addition to passive control for the entire spacecraft system to maintain thermal regulation in eclipses (25). Additionally, as biological payloads become more common on small spacecraft, their temperature limits must be considered and maintained as well. NASA ARC biological nanosats (GeneSat, PharmaSat, O/OREOS, SporeSat, EcAMSat, and BioSentinel) all used actively-controlled heaters for precise temperature maintenance for their biological payloads, with closed-loop temperature feedback to maintain temperatures.

### 7.3.2 Cryocoolers

Cryocoolers are refrigeration devices designed to cool around 100K and below. A summary of cryocooler systems is given in figure 7.18 and a detailed review of the basic types of cryocoolers and their applications is given by Radebaugh (26). The first two systems (a) and (b) are recuperative cycles, and (c), (d), and (e) are regenerative cycles. Cryocoolers are used on instruments or subsystems requiring cryogenic cooling, such as high precision IR sensors. Instruments such as imaging spectrometers, interferometers and midwave infrared (MWIR) sensors require cryocoolers to function at extremely low temperatures. The low temperature improves the dynamic range and extends the wavelength coverage. The use of cryocoolers is also associated with longer instrument lifetimes, low vibration, high thermodynamic efficiency, low

mass, and supply cooling temperatures less than 50K (27). Cryocoolers on small spacecraft are still a new concept, however there have been two CubeSats with cryocooling on board. Lunar IceCube, a 6U secondary payload on-board Artemis I and developed by Morehead State University, will use a 600 mW cryocooler for its BIRCHES point spectrometer (28). Below are cryocooler descriptions on from commercial vendors.

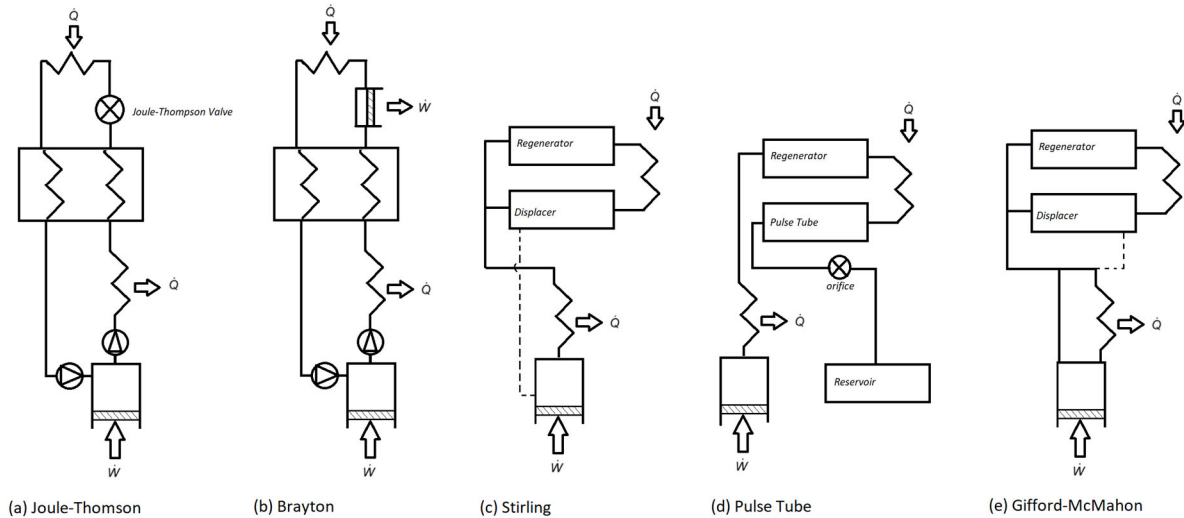


Figure 7.18: A comparison of cryocooler types. Credit: NASA.

Creare developed an Ultra-Low Power (ULP) single-stage, turbo-Brayton cryocooler that operates between a cryogenic heat rejection temperature and the primary load temperature (figure 7.19). The cryocooler includes a cryogenic compressor, a recuperative heat exchanger, and a turboalternator.

The continuous flow nature of the cycle allows the cycle gas to be transported from the compressor outlet to a heat rejection radiator at the warm end of the cryocooler and from the turboalternator outlet to the object to be cooled at the cold end of the cryocooler (29).

This cryocooler is designed to operate at cold end temperatures of 30 to 70K, with loads of up to 3 W, and heat rejection temperatures of up to 210K by changing only the charge pressure and turbo machine operating speeds. This technology has completed testing and fabrication and is TRL 6. The development of this technology has not specifically targeted small satellite applications, but with its comparatively low power requirements could be adapted to SmallSats in the future. An additional benefit is it produces negligible vibration with minimal impact on pointing accuracy or imaging.

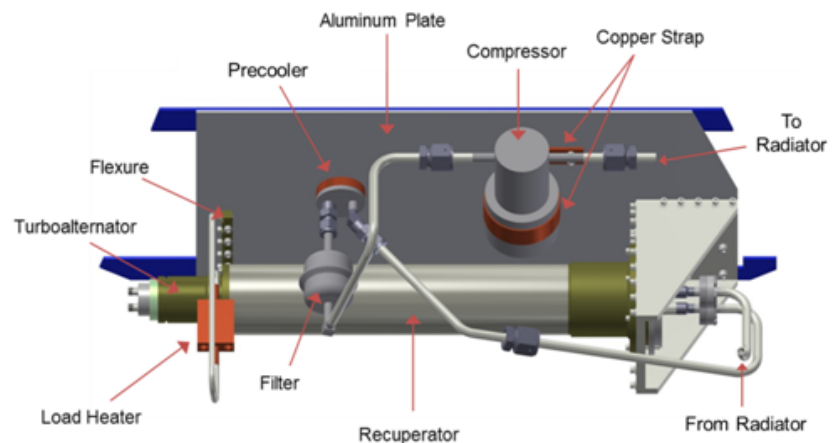


Figure 7.19: Configuration of primary mechanical ULP cryocooler components. Credit: Creare, Inc.

A reverse turbo-Brayton cryocooler that produces negligible vibration is also being developed by Creare. This technology uses a continuous flow of gas to transport heat from the active elements of the cryocooler to the objects to be cooled and to heat rejection surfaces.

Ricor-USA, Inc. developed the K562S, a rotary Sterling mini micro-cooler. It has a cooling capacity of 200 mW at 95 K and 300 mW at 110K. It has been used in several small gimbals designed for military applications (30). Ricor also developed K508N, a Sterling ½ W micro cooler that has a cooling capacity of 500 mW at 77 K and 700 mW at 77K that is suitable for small spacecraft (31). These coolers, shown in figure 7.20, are TRL 6 for small spacecraft applications.

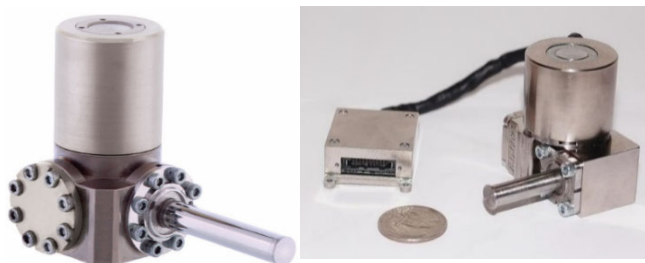


Figure 7.20: (left) K508N 1/2 W Micro Cooler, and (right) K562S Mini-cooler. Credit: Ricor-USA.

Sunpower, Inc. developed the CryoTel DS1.5 Sterling Cryocooler (figure 7.21) features a dual-opposed-piston pressure wave generator and a separate cold head to minimize exported vibration and acoustic noise, with a nominal heat lift of 1.4 W at 77K using 30 W power with a 1.2 kg mass (32). Sunpower also offers MT-F, a mini-cooler that has a nominal heat lift of 5 W at 77K, using 80 W power with a total mass of 2.1 kg. So far, these units have not been used in small spacecraft applications but are candidates given their size and performance.

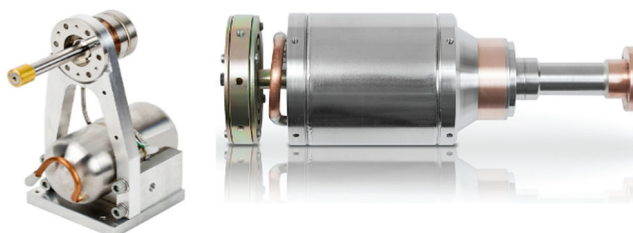


Figure 7.21: (left) CryoTel DS1.5 1.4 W Cryocooler and (right) CryoTel MT-F 5 W Cryocooler. Credit: Sunpower, Inc.

Northrop Grumman designed a Micro Pulse Tube cooler that is a split-configuration cooler that incorporates a coaxial coldhead connected via a transfer line to a vibrationally balanced linear compressor. This micro compressor has been scaled from a flight proven, high efficiency cooler (HEC) compressor, although it has not operated on a SmallSat. It has a TRL of 6. The cooler has an operational range of 35 to 40K and a heat rejection temperature of 300K, using 80 W of input power, has 750 mW refrigeration at 40K, and a total mass of 7.4 kg (33).

Lockheed Martin Space Systems Company has engineered a pulse tube micro-cryocooler, a simplified Sterling cryocooler consisting of a compressor driving a coaxial pulse tube coldhead, shown in figure 7.22. The unit has a mass of 0.345 kg for the entire thermal mechanical unit and is compact enough to be packaged in a ½U CubeSat (34). After qualification testing, the microcooler is at TRL 6 and is compatible with small spacecraft missions.



Figure 7.22: TRL6 Microcryocooler. Credit: Lockheed Martin.

Thales Cryogenics has also developed a Linear Pulse Tube (LPT) cryocooler that has gone through extensive testing by JPL. The Thales LPT9510 cryocooler has an operating temperature range of -40 to 71°C, an input



power of <85 W, and a total unit mass of 2.1 kg. The unit has no flight heritage but has undergone extensive testing and is TRL 6 (35)

### 7.3.3 Thermoelectric Coolers (TEC)

TECs are miniature solid-state heat pumps which provide localized cooling via the Peltier effect, which is cooling resulting from passing electric current through a junction formed by two dissimilar metals. TECs have been used to cool star trackers, IR sensors and low noise amplifiers. Advantages of TECs are that they have no moving parts, are reliable, noiseless, lightweight, and compact. Their use is limited by low efficiency below temperatures of 130K and low performance with large temperature differences. Furthermore, the TECs are fragile to mount and highly sensitive to thermal expansion stresses. External stresses can be mitigated by adding a conductive strap on the cold side (36).

### 7.3.4 Fluid Loops

A pumped fluid loop (PFL) consists of a circulating pump that moves a liquid through tubing connected to a heat exchanger and heat sink. A heat source is mounted to the heat exchanger and the pumped fluid carries the heat from the source to a heat sink, typically a radiator, and then the cooled fluid is returned to the heat source to continue providing cooling. A PFL is capable of cooling multiple locations via forced fluid convective cooling. Mechanically pumped fluid loops (MPFL) are not typically used on SmallSats because they are associated with high power consumption and mass.

Lockheed Martin Corporation is developing a low mass circulator pump for a closed-cycle Joule Thomson cryocooler, as shown in figure 7.23. With an overall mass of 0.2 kg, it can circulate gas as part of a single-phase or two-phase thermal management system using 1.2 W of electrical power and can manage around 40 W of spacecraft power as a single-phase loop, or several hundred Watts of spacecraft power as part of a 2-phase loop. The compressor went through applicable testing with a compression efficiency of 20 – 30% in a 2016 study (37). This design is TRL 4.

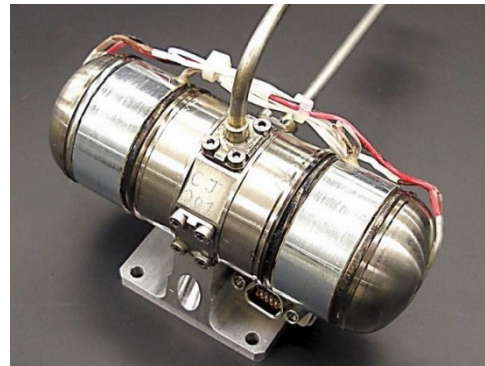


Figure 7.23: JT Compressor. Credit: Lockheed Martin.

### 7.3.5 Active Thermal Architecture

The Active Thermal Architecture (ATA) system is an advanced, active thermal control technology for small satellites in support of advanced missions in deep space, helio-physics, earth science, and communications. The ATA technology is capable of high-power thermal rejection, and zonal temperature control of satellite busses, payloads, and high-energy density components. The ATA project was developed by the Center for Space Engineering at Utah State University (CSE, USU) and funded by the NASA SST program in partnership with JPL.

The ATA is a sub 1U two-stage active thermal control system targeted at 6U CubeSat form factors and larger. The first stage consists of a mechanically pumped fluid loop (MPFL). A micro-pump circulates a single-phase heat transfer fluid between an internal heat exchanger and a deployed tracking radiator. The second stage is composed of a miniature tactical cryocooler, which directly provides cryogenic cooling to payload instrumentation. The conceptual operation of the ATA system is shown in figure 7.24.

Ultrasonic additive manufacturing (UAM) techniques were used to simplify and miniaturize the ATA system by embedding the MPFL fluid channels directly into the integrated HX, CubeSat chassis, and the external radiator, creating integrated multi-function structures. The ATA system

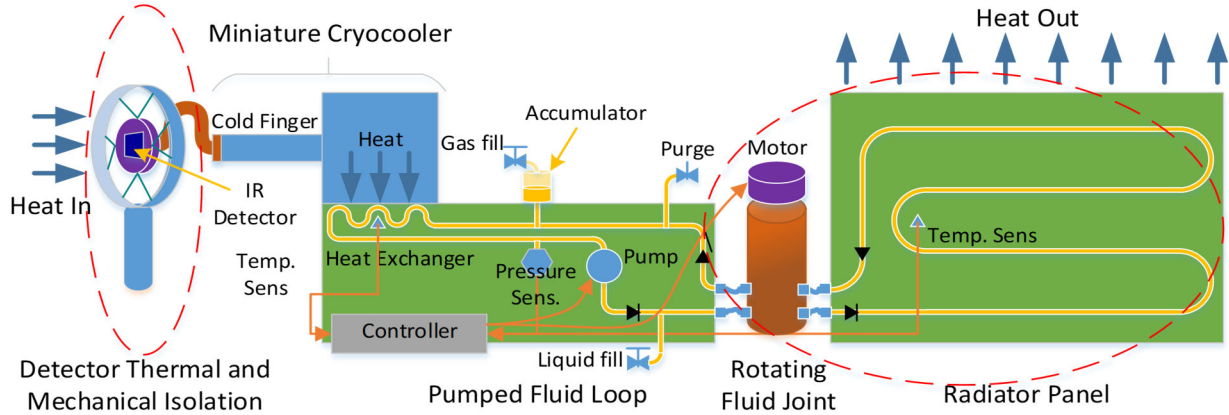


Figure 7.24: Conceptual operation of the ATA thermal control system. Credits: CSE/USU/NASA/JPL.

also features flexible, multi-axis rotary fluid unions, and an integrated geared micro-motor which allows for the two-stage deployment and solar tracking of the ATA radiator. The ATA also features passive vibration isolation and jitter cancellation technologies such as a floating wire-rope isolator design, particle damping, flexible PGS thermal links and a custom Kevlar isolated cryogenic electro-optical detector mount. Figure 7.25 shows some of the technologies developed for ATA as well as the ground-based prototype CubeSat.

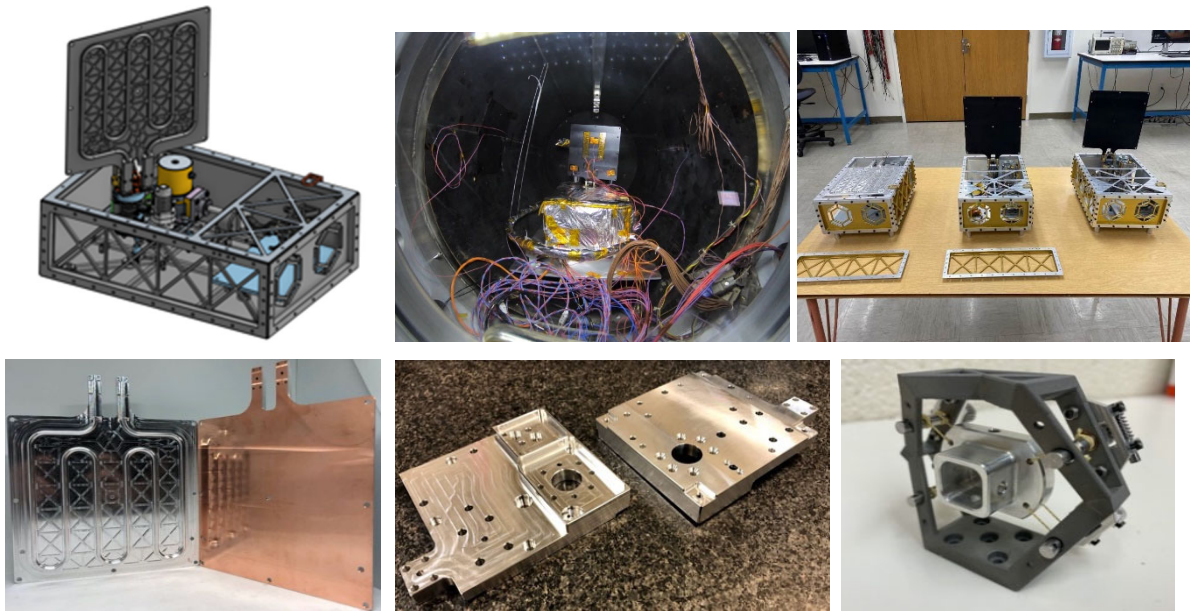


Figure 7.25: From top left: ATA CubeSat prototype, ATA subsystem testing, ATA prototypes, UAM radiator with copper backing, UAM heat exchanger, Kevlar isolated Cryogenic Electro-optical prototype mount. Credit: CSE/USU/NASA/JPL.

## 7.4 Summary

As thermal management on small spacecraft is limited by mass, surface area, volume and power constraints, traditional passive technologies, such as paints, coatings, tapes, MLI, and thermal straps, dominate thermal design. Active technologies, such as thin flexible resistance heaters have also seen significant use in small spacecraft, including some with advanced closed-loop



control. Many technologies that have to date only been integrated on larger spacecraft are being designed, evaluated, and tested for small spacecraft to meet the growing needs of SmallSat developers as small satellites become more and more advanced. Deployable solar panels that have been used by many other SmallSats are paving the way for thermal deployable components, while advanced deployable radiators and thermal storage units are still undergoing testing for small spacecraft.

Technology in active thermal control systems has started expanding to accommodate volume and power restrictions of a smaller spacecraft; cryocoolers are being designed to fit within 0.5U volume that will allow small spacecraft to use optical sensors and imaging spectrometers.

For feedback solicitation, please email: [arc-sst-soa@mail.nasa.gov](mailto:arc-sst-soa@mail.nasa.gov). Please include a business email.

## 7.5 References

- (1) A. Anvari, F. Farhani, and K. S. Niaki. "Comparative Study on Space Qualified Paints Used for Thermal Control of a Small Satellite." 2009.
- (2) Sheldahl, A Flex Company. "The Red Book". Jan 24, 2020 REV E. Available at: [https://www.sheldahl.com/sites/default/files/2020-02/RedBook\\_0.pdf](https://www.sheldahl.com/sites/default/files/2020-02/RedBook_0.pdf)
- (3) Dunmore Aerospace. "MLI: Satkit." [Online] Accessed 2018. Available at: <https://www.dunmore.com/products/satkit-mli.html>
- (4) Thermal Management Technologies. "Products, Thermal Components: Flexible Thermal Straps." [Online] Accessed 2018. Available at: <https://www.tmt-ipe.com/thermal-components>
- (5) Boyd Corporation. "Flexible Thermal Conductors -- Thermal Straps & Strap Assemblies." Datasheet. [Online] 2020. Accessed 2022. Available at: <https://info.boydcorp.com/hubfs/Thermal/Conduction-Cooling/Boyd-Thermal-Straps-Technical-Datasheet.pdf>
- (6) Technology Applications, Inc. "Graphite Fiber Thermal Straps (GFTS)." [Online] 2022. Available at: <https://www.techapps.com/graphite-fiber-thermal-straps>
- (7) E. Urquiza, C. Vasquez, J. Rodriguez, and B. V. Gorp. "Development and testing of an innovative two-arm focal-plane thermal strap (TAFTS)." *Cryogenics*, Volume 52, Issues 4–6, 2012, Pages 306-309.
- (8) Thermotive. "Products: Thermal Straps." [Online] 2019. Available at: <http://www.thermotive.com/thermalstraps.html>
- (9) D., Gilmore. "Spacecraft Thermal Control Handbook, Volume I, Fundamental Technologies, Chapter 8: Mountings and Interfaces." 2002.
- (10) Laird Technologies. Tflex HD80000 Series Thermal Gap Filler. Laird Technologies. Datasheet. [Online] Available at: <https://www.laird.com/sites/default/files/tflex-hd80000-datasheet.pdf>
- (11) Laird Technologies. "Tgon 800 Series Electrically and Thermally Conductive Interface Pad." Datasheet. [Online] Available at: <https://www.laird.com/sites/default/files/tgon-800-datasheet.pdf>
- (12) Henkel Corporation, Bergquist. "Thermal Interface Materials Selection Guide. Bergquist." [Online] 2019. Available at: <https://dm.henkel-dam.com/is/content/henkel/lt-8116-brochure-thermal-interface-materials-selection-guidepdf>
- (13) Sierra Lobo. "CryoCube." [Online] 2019. Available at: <https://sierralobo.com/research-technology/cryocube/>
- (14) NASA. "NASA Begins Checkout of Dellinger Spacecraft Designed to Improve Robustness of CubeSat Platforms." [Online] November 28, 2017. Available at:



- <https://www.nasa.gov/feature/goddard/2017/nasa-begins-checkout-of-dellingr-spacecraft-designed-to-improve-robustness-of-cubesat>
- (15) Thermal Management Technologies. "Thermally Efficient Deployable Radiators." Datasheet. [Online] 2021. Available at: <https://www.tmt-ipe.com/product-sheets>
  - (16) E. Urquiza, B.X. Zhang, M.P. Thelen, J.I. Rodriguez, and S. Pellegrino. "Folding Elastic Thermal Surface - FETS." [Online] June 1, 2013. Available at: <https://www.techbriefs.com/component/content/article/tb/pub/techbriefs/mechanics-and-machinery/16598>
  - (17) H.J. Kramer. "BIRD (Bi-Spectral Infrared Detection)." [Online] May 25, 2012. Available at: <https://directory.eoportal.org/web/eoportal/satellite-missions/b/bird>
  - (18) Y. Nakamura et al. "Small Demonstration Satellite-4 (SDS-4): Development, Flight Results, and Lessons Learned in JAXA's Microsatellite Project." 27<sup>th</sup> Annual AIAA/USU Conference on Small Satellites, Logan, UT. 2013.
  - (19) Thermal Management Technologies. "Thermal Storage Units." Datasheet. [Online] 2021. Available at: <https://www.tmt-ipe.com/product-sheets>
  - (20) Redwire Space. "Thermal Energy Storage Panel: Q Store," [Online] 2022. Available at: <https://redwirespace.com/products/qstore/?rdws=nnn.szex.tfd&rdwj=43870>
  - (21) D. Gilmore. Spacecraft Thermal Control Handbook, Volume I, Fundamental Technologies, Chapter 10: Heat Switches. 2002.
  - (22) NASA. NASA Technology Taxonomy and the NASA Strategic Technology Integration Framework, TX 14: Thermal Management Systems. [Online] July 2020. Available at: [https://www.nasa.gov/sites/default/files/atoms/files/2020\\_nasa\\_technology\\_taxonomy\\_lowres.pdf](https://www.nasa.gov/sites/default/files/atoms/files/2020_nasa_technology_taxonomy_lowres.pdf)
  - (23) Thermal Management Technologies. "Products: Small Spacecraft Structures. Thermal Management Technologies." [Online] 2019. Available at: <https://www.tmt-ipe.com/small-spacecraft-structures>
  - (24) K. Hogstrom. "State-of-the-Art Thermal Analysis Methods and Validations for Small Spacecraft." Ae241 Literature Survey. March 4, 2013.
  - (25) D. Hengeveld, J. Braun, E. Groll, and A. Williams. "Review of Modern Spacecraft Thermal Control Technologies and Their Application to Next-Generation Buildings." 2010. International High Performance Buildings Conference. Paper 40.
  - (26) R. Radebaugh. "Refrigeration for superconductors." 2004, IEEE, pp. 1719 - 1734 .
  - (27) R. Hon, C. Kesler, and D. Sigurdson. "Integrated Testing of a Complete Low Cost Space Cryocooler System." 2009.
  - (28) B. K. Malphrus et al. "The Lunar IceCube EM-1 Mission: Prospecting the Moon for Water Ice." Institute of Electrical and Electronics Engineers A&E Systems Magazine. April 2019
  - (29) M. V. Zagarola, R. W. Hill, J. R. Gagne, and R. W. Kaszeta. "*Ultra Low Power Cryo-Refrigerator for Space Applications.*" International Cryocooler Conference, Inc., Boulder, CO, 2014.
  - (30) Ricor-USA. "K562S." [Online] 2022. Available at: <https://www.ricor.com/products/k562s/>
  - (31) Ricor-USA. "K508N." [Online] 2022. Available at: <https://www.ricor.com/products/k508n/>
  - (32) Sunpower Inc. "CryoTel Cryocoolers." [Online] 2022 Available at: <https://www.sunpowerinc.com/products/stirling-cryocoolers/cryotel-cryocoolers>
  - (33) D. Durand, E. Tward, G. Toma, and T. Nguyen. "*Efficient High Capacity Space Microcooler.*" International Cryocooler Conference, Inc., Boulder, CO, 2014.





- (34) J. Nast, E. Roth, T. Olson, P. Champagne, and D. Frank. "Qualification of Lockheed Martin Micro Pulse Tube Cryocooler to TRL6." International Cryocooler Conference, Inc., Boulder, CO, 2014.
- (35) Thales Cryogenics. "Linear Pulse-tube coolers." [Online] Available at: <https://www.thalesgroup.com/en/markets/market-specific-solutions/cryogenics-activities/linear-pulse-tube-coolers>
- (36) D., Gilmore. Spacecraft Thermal Control Handbook, Volume I, Fundamental Technologies, Chapter 13: Thermoelectric Coolers. 2002
- (37) P. Champagne, J.R. Olsen, T. Nast, E. Roth, A. Collaco, G. Kaldas, E. Saito, V. Loung. "*Development of a J-T Micro Compressor.*" IOP Conf. Series: Materials Science and Engineering 101 (2015) 012009.



## Table of Contents

Glossary .....	ii
8.0 Small Spacecraft Avionics .....	207
8.1 Introduction .....	207
8.2 Avionics Systems Platform and Mission Development Considerations .....	208
8.3 State-of-the-Art (TRL 5-9): Command and Data Handling .....	209
8.3.1 Avionics and Onboard Computing Form Factors .....	210
8.3.2 Highly Integrated Onboard Computing Products .....	210
8.3.3 Radiation-Hardened Processors .....	218
8.3.4 Memory, Electronic Function Blocks, and Components .....	218
8.3.5 Bus Electrical Interfaces .....	219
8.3.6 Radiation Mitigation and Tolerance Schemes .....	219
8.4 State-of-the-Art (TRL 5-9): Flight Software .....	220
8.4.1 Implication of CDH Processors on FSW .....	220
8.4.2 Frameworks .....	221
8.4.3 Operating Systems .....	221
8.4.4 Software Languages .....	221
8.4.5 Mission Operations and Ground Support Suites .....	221
8.4.6 Development Environment, Standards, and Tools .....	221
8.5 On the Horizon (TRL 1-4): Command and Data Handling .....	222
8.6 On the Horizon (TRL 1-4): Flight Software .....	222
8.7 Summary .....	223
References .....	224



## Glossary

(ASICs)	Application-specific Integrated Circuits
(CDH)	Command and Data Handling
(COTS)	Commercial-off-the-shelf
(CRAM)	Chalcogenide RAM
(DDD)	Displacement Damage Dose
(DRAM)	Dynamic RAM
(EPS)	Electrical Power System
(FERAM)	Ferro-Electric RAM
(FPGAs)	Field Programmable Gate Arrays
(FSW)	Flight Software
(I/O)	Input & Output
(LEO)	Low-Earth Orbit
(MRAM)	Magnetoresistive RAM
(OBC)	Onboard Computer
(PCM)	Phase Change Memory
(Rad-hard)	Radiation-hardened
(SDRs)	Software-defined Radios
(SEEs)	Single-event Effects
(SEL)	Single-event Latch-up
(SEUs)	Single-event Upsets
(SoCs)	System-on-chip
(SRAM)	Static Random-Access Memory
(SSA)	Small Spacecraft Avionics
(SWaP)	Size, Weight, and Power
(SWaP-C)	Size, Weight, Power, and Cost
(TID)	Total Ionizing Dose



## 8.0 Small Spacecraft Avionics

### 8.1 Introduction

Small Spacecraft Avionics (SSA) are described as all electronic subsystems, components, instruments, and functional elements included in the spacecraft platform. These include primarily flight sub-elements Command and Data Handling (CDH), Flight Software (FSW), and other critical flight subsystems, including Payload and Subsystems Avionics (PSA). All must be configurable into specific mission platforms, architectures, and protocols, and be governed by appropriate operations concepts, development environments, standards, and tools. The CDH and FSW are considered to be the brain and nervous system of the integrated avionics system, and generally provide command, control, communication, and data management interfaces with all other subsystems in some manner, whether in a direct point-to-point, distributed, integrated, or hybrid computing mode. The avionics system is essentially the foundation for all components and their functions integrated on the spacecraft. As the nature of the mission influences the avionics architecture design, there is a large degree of variability in avionics systems.

There are two major factors to consider for SmallSat avionics:

1. Scale of spacecraft: a traditional spacecraft is a high-size, weight, power, and cost (SWaP-C), flagship system, so it'll have a high-SWaP-C avionics system, typically to reduce risk and address higher reliability requirements. A SmallSat is a low-SWaP-C, miniature system, so it'll have a low-SWaP-C avionics system. Typically, due to low cost, more risk is often tolerable, but nonetheless, reliability enhancements can be applied to increase reliability. Individually, the avionics system scales with the spacecraft, however constellations of SmallSats can “match” the capabilities of a traditional spacecraft (using multiple cheap units versus one expensive unit).

2. Architecture design: the architecture design is not necessarily dependent on the scale of the spacecraft. In both traditional spacecraft and SmallSats, the avionics system can be either centralized or decentralized, simplex or fault-tolerant, and modular or monolithic. Traditional spacecraft are very expensive, and to reduce risk, the avionics may employ redundancy such that if one element fails, the entire architecture is able to continue, but SmallSat avionics designs are more centralized, whereby if one element fails, the system fails. Figure 8.1 illustrates an architectural block diagram of a centralized small spacecraft system. In anticipation of extended durations in low-Earth orbit (LEO) and deep space missions, designers are now incorporating radiation-hardened (rad-hard) or radiation-tolerant architecture designs in their SSA packages to further increase their overall reliability.

This chapter focuses significantly on commercial products and developments, however vendors are not the only ones developing avionics platforms. There are numerous government/academic efforts worth considering, with a few examples below:

- SpaceCube and MUSTANG, by NASA GSFC (government)
- Sabertooth by JPL
- CHREC/SHREC Space Processor, by NSF SHREC (academic)
- RadPC by Montana State University (academic)

Given the distributed and integrated nature of modern SSA, this chapter organizes the state-of-the-art in SSA into CDH (8.3) and FSW (8.4). On-the-Horizon activities (TRL <5) for CDH and FSW (8.5 and 8.6, respectively) highlight recent developments in next-generation SSA systems. Avionics Systems Platform and Mission Development Considerations (8.2) discusses how these considerations are being addressed and/or mitigated by state-of-the-art advances in CDH, FSW, and PSA products. A summary of future SSA systems is provided in (8.7).

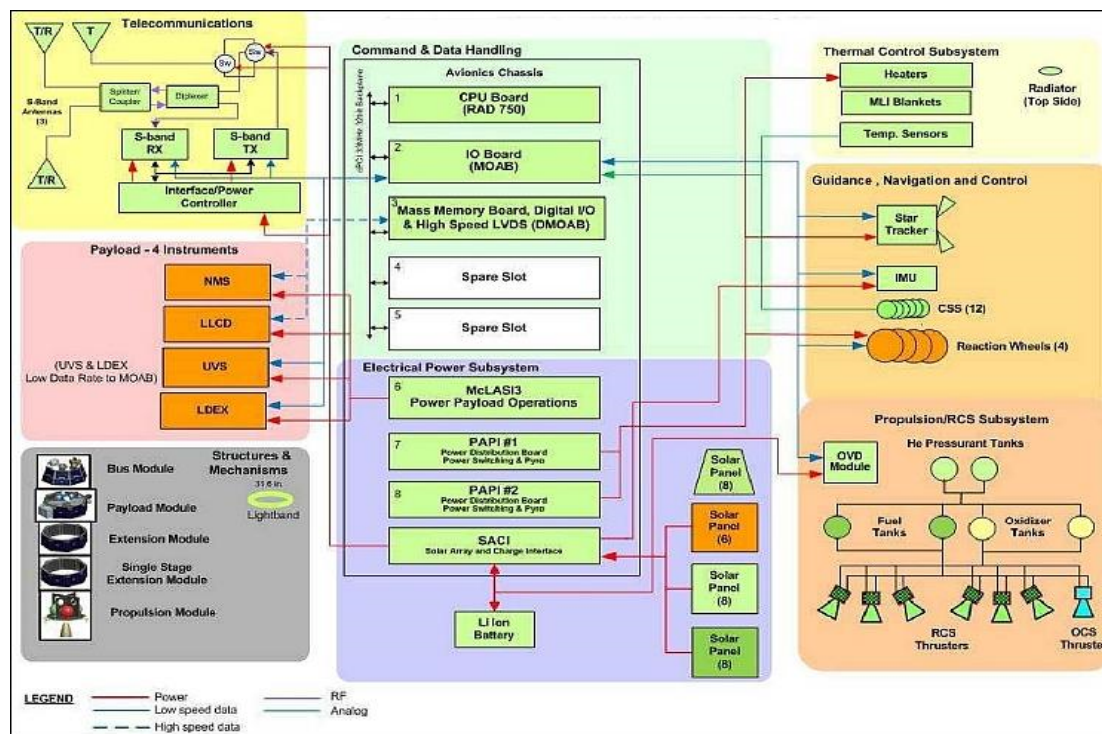


Figure 8.1: Functional block diagram of the LADEE spacecraft. Credit: NASA ARC.

The information described below is not intended to be exhaustive but provides an overview of current state-of-the-art technologies and their development status. It should be noted that Technology Readiness Level (TRL) designations may vary with changes specific to payload, mission requirements, reliability considerations, and/or the environment in which performance was demonstrated. Readers are highly encouraged to reach out to companies for further information regarding the performance and TRL of described technology. There is no intention of mentioning certain companies and omitting others based on their technologies or relationship with NASA.

## 8.2 Avionics Systems Platform and Mission Development Considerations

There are many factors to be considered in selecting the optimum configuration and implementation of avionics subsystems, components, and elements for small spacecraft missions. Overall spacecraft concerns of Size, Weight and Power (SWaP) always need to be considered. Some of the more pertinent issues and concerns that all small spacecraft missions must address include:

- Mission applicability and tailoring
- Element, module, and component modularity and interoperability
- Manufacturing and production efficiency, complexity, and scaling
- Mission environment, especially radiation and long-duration space exposure
- Standards and regulatory concerns
- SWaP-C constraints

In addition to CDH and FSW, state-of-the-art SSA systems should consider the following subsystem/payload specific electronic systems:

- Small spacecraft platform size ranges and configurations



- Integrated avionics platform architectures
- Mission avionics configurations
- Spacecraft and mission autonomy

Flight payload and subsystems avionics elements include:

- Subsystem integrated onboard computer (OBC) controllers
- Integrated systems health avionics
- Onboard payload processors
- Cloud-based processors

Modular avionics architectures for small spacecraft can be characterized as either federated or integrated. In a federated avionics architecture, each subsystem of the spacecraft is considered an independent, dedicated autonomous element, with the avionic components performing all functions independently and exchanging data over standardized communications protocols and interfaces. An integrated avionics architecture is a shared, distributed functionality, that can be configured with distributed, heterogeneous and/or mixed criticality elements. In either case, modular avionics architectures can be configured with smart subsystem capabilities, redundant fault tolerant radiation, and anomaly mitigation procedures.

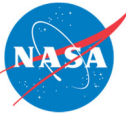
Constellation networks and swarms, synchronized formations, and other multi-satellite cluster formations are creating new opportunities for SSA. The increased need for synchronization, intersatellite communications, controlled positioning for integrated CDH functionality, coordination and conduct, operation of ConOps, and autonomous operations impose new constraints on the avionics system. This is true not only for single satellites, but now also for multi-satellite configurations, whereby overall mission performance is dependent on all the platform elements acting in a co-dependent fashion.

### **8.3 State-of-the-Art (TRL 5-9): Command and Data Handling**

Current trends in small spacecraft CDH generally appear to be following those of previous, larger scale CDH subsystems. The current generation of microprocessors can easily handle the processing requirements of most CDH subsystems and will likely be sufficient for use in spacecraft bus designs for the foreseeable future. Cost and availability are likely primary factors for selecting a CDH subsystem design from a given manufacturer, but many groups develop their own custom platforms. The ability to spread nonrecurring engineering costs over multiple missions and reduce software development through reuse are both desirable factors in a competitive market. Heritage designs work well for customers looking to select components with proven reliability for their mission. SmallSat CDH should consider the following:

1. Avionics and onboard computing form factors
2. Highly integrated onboard computing products
3. Rad-hard processors and FPGAs
4. Memory, electronic function blocks, and components
5. Bus electrical CDH interfaces
6. Radiation mitigation and tolerance schemes

As small satellites move from the early CubeSat designs with short-term mission lifetimes to potentially longer missions, radiation tolerance becomes significant when selecting parts. These distinguishing features, spaceflight heritage and radiation tolerance, are the primary differentiators in the parts selection process for long-term missions, verses those which rely heavily on commercial-off-the-shelf (COTS) parts. Experimental missions typically focus on low-



cost, easy-to-develop systems that take advantage of open-source software and hardware to provide an easy entry into space systems development, especially for hobbyists or those who lack specific spacecraft expertise.

Small spacecraft CDH technologies and capabilities have been continuously evolving, enabling new opportunities for developing and deploying next-generation SSA. When small spacecraft were first introduced, a primary purpose was to observe and send information back to Earth. As awareness and utility have expanded, there is a need to improve the overall capability of data collection for specific mission environments beyond LEO. Small spacecraft, including nanosatellites and CubeSats, currently perform a wide variety of science in LEO, and these smaller platforms are emerging as candidates for more formidable beyond-LEO missions.

The adoption of CubeSat and SmallSat technology is enabled by the miniaturization of electronics, sensors, and instruments. As spacecraft manufacturers begin to use more space-qualified parts, they find that those devices can often lag their COTS counterparts by several generations in performance but may be the only means to meet the radiation requirements placed on the system. Presently, there are several commercial vendors who offer highly integrated systems that contain the onboard computer, memory, electrical power system (EPS), and the ability to support a variety of Input & Output (I/O) for the CubeSat class of small spacecraft. A variety of CDH developments for CubeSats have occurred due to in-house development, the rise of new companies that specialize in CubeSat avionics, and the use of parts from established companies who provide spacecraft avionics for the space industry in general. While parallel developments are impacting the growth of CubeSats, vendors with ties to the more traditional spacecraft bus market are increasing CDH processing capabilities within their product lines.

In-house designs for CDH units are being developed by some spacecraft bus vendors to better accommodate small vehicle concepts. While these items generally exceed CubeSat form factors in size, they can achieve similar environmental performance and may be useful in small satellite systems that replicate more traditional spacecraft subsystem distribution.

### **8.3.1 Avionics and Onboard Computing Form Factors**

The CompactPCI and PC/104 form factors continue generally to be the industry standard for CubeSat CDH bus systems, with multiple vendors offering components that can be readily integrated into space-rated systems. Overall, form factors should fit within the standard CubeSat dimension of less than  $10 \times 10 \text{ cm}^2$ . Spacecraft avionics components are performance-driven and not necessarily dependent on spacecraft platform sizes, but some noncontainerized spacecraft platforms may need to consider using higher TRL avionics products and whether or not these products are available. The PC/104 form factor was the original inspiration to define standard architecture and interface configurations for CubeSat processors, but with space at a premium, many vendors have been using all available space exceeding the formal PC/104 board size. Although the PC/104 board dimension continues to inspire CubeSat configurations, some vendors have made modifications to stackable interface connectors to address reliability and throughput concerns. Many vendors have adopted the use of stackable "daughter" or "mezzanine" boards to simplify connections between subsystem elements and payloads, and to accommodate advances in technologies that maintain compatibility with existing designs. A few vendors provide a modular package which allows users to select from a variety of computational processors.

### **8.3.2 Highly Integrated Onboard Computing Products**

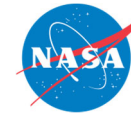
A variety of vendors are producing highly integrated, modular, onboard computing systems for small spacecraft. These CDH packages combine processors and/or Field Programmable Gate Arrays (FPGAs) with various memory banks, and with a variety of standard interfaces for other subsystems onboard. FPGAs and software-defined architectures also give designers a level of



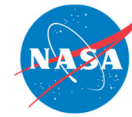
flexibility to integrate uploadable software modifications to adapt to new requirements and interfaces. Table 8-1 summarizes the current state-of-the-art for some of these components. Since traditional CubeSat designs are based primarily on COTS parts, spacecraft vendors often try to use parts that have radiation tolerance or have been radiation-hardened, as noted in the pedigree column in table 8-1. The vehicle column shows which spacecraft classification corresponds to each onboard unit; "general satellite" classification refers to larger SmallSat platforms (i.e., larger than CubeSats). It should be noted that while some products have achieved TRL 9 by virtue of a space-based demonstration, what is relevant in one application may not be relevant to another, and different space environments and/or reliability considerations may result in lower TRL assessments. Some larger, more sophisticated computing systems have significantly more processing capability than what is traditionally used in SmallSat CDH systems, however the increase in processing power may be a useful tradeoff if payload processing and CDH functions can be combined (note that overall throughput should be analyzed to assure proper functionality under the most stressful operating conditions).

System developers are gravitating towards ready-to-use hardware and software development platforms that can provide seamless migration to higher performance architectures. As with non-space applications, there is a reluctance to change controller architectures due to the cost of retraining and code migration. Following the lead of microprocessor and FPGA vendors, CubeSat avionics vendors are now providing simplified tool sets and basic, cost-effective evaluation boards.



**Table 8-1: Sample of Highly Integrated Onboard Computing Systems**

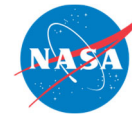
<b>Manufacturer</b>	<b>Product</b>	<b>Processor</b>	<b>Pedigree</b>	<b>Vehicle</b>	<b>TRL</b>	<b>Ref</b>
GomSpace	Nanomind A3200	Atmel AT32UC3C MCU	COTS	CubeSat	Ukn	(1)
ISISPACE	iOBC	ARM 9	COTS	CubeSat	9	(2)
Pumpkin	PPM A1	TI MSP430F1612	COTS	CubeSat	9	(3)
	PPM A2	TI MSP430F1611	COTS	CubeSat	9	
	PPM A3	TI MSP430F2618	COTS	CubeSat	9	
	PPM B1	Silicon Labs C8051F120	COTS	CubeSat	9	
	PPM D1	Microchip PIC24FJ256GA110	COTS	CubeSat	9	
	PPM D2	Microchip PIC33FJ256GP710	COTS	CubeSat	9	
	PPM E1	Microchip PIC24FJ256GB210	COTS	CubeSat	9	
Xiphos	Q7S	AMD-Xilinx Zynq-7020 Dual-core ARM Cortex-A9	COTS w/ SEE mitigation	Nano-, Micro-, and SmallSats	9	(4)
	Q8S	AMD-Xilinx Zynq Ultrascale+ MPSOC Quad-core ARM Cortex-A53	COTS w/ SEE mitigation	Nano-, Micro-, and SmallSats	8	(5)
BAE	RAD750	RAD750	rad-hard	General Satellite	9	(6)
	RAD5545	RAD5545	rad-hard by design	General Satellite	6	(7)
AAC Clyde Space	Kryten-M3	Microchip SmartFusion 2 ARM Cortex-M3	COTS	CubeSat	9	(8)
	Sirius OBC & TCM	SmartFusion Cortex-M3	COTS w/ SEE mitigation	SmallSat	9	(9)



Innoflight	CFC-300	AMD-Xilinx Zynq-7020 Dual-core ARM Cortex-A9	COTS	CubeSat	Ukn	(10)
	CFC-400	AMD-Xilinx Zynq Ultrascale+ MPSoC Quad-core ARM Cortex-A53	COTS	CubeSat	Ukn	(11)
	CFC-500	Microchip PolarFire with RISC-V soft core and NVIDIA TK1	COTS	CubeSat	Ukn	(12)
Space Micro	CSP	AMD-Xilinx Zynq-7020 Dual-core ARM Cortex-A9	COTS	CubeSat	Ukn	(13)
NanoAvionics	SatBus 3C2	STM32 ARM Cortex-M7	COTS	CubeSat	9	(14)
MOOG	G-Series Steppe Eagle	AMD G-Series compatible	Rad Hard by design	General Satellite	Ukn	(15)
	V-Series Ryzen	AMD V-Series compatible	Rad Hard by design	General Satellite	Ukn	
	BRE440	PPC440 Core	Rad Hard by design	General Satellite	Ukn	(16)
SEAKR	Athena-3 SBC	PowerPC e500	Ukn	General Satellite	9	(17)
	Medusa SBC	PowerPC e500	Ukn	General Satellite	9	
	RCC5	AMD-Xilinx Virtex 5 FX-130T	Ukn	General Satellite	9	
Unibap	iX10-100	Microchip PolarFire FPGA with RISC- V, AMD V1605b (Ryzen) CPU and GPU, and up to 3 Intel Movidius Myriad X VPUs and optional NVMe- based compute storage (up to 8 TB)	COTS with SEE mitigation	Nano-, Micro- and SmallSats	5	(18)



	iX5-100	Microchip SmartFusion 2 ARM Cortex-M3 and AMD G-Series SOC	COTS with SEE mitigation	Nano-, Micro- and SmallSats	8	(19)
	e2160	Microchip SmartFusion 2 FPGA with ARM Cortex-M3 and AMD 2 <sup>nd</sup> generation G-Series SOC CPU and GPU	COTS with SEE mitigation	Nano-, Micro- and SmallSats	9	(20)
	e2155	Microchip SmartFusion 2 FPGA with ARM Cortex-M3 and AMD 1 <sup>st</sup> generation G-Series SOC CPU and GPU	COTS with SEE mitigation	Nano-, Micro- and SmallSats	9	
Nara Space	NSTOBC	AT91SAM9	COTS	CubeSat, SmallSat	9	(21)
Argotec	OBC FERMI	Dual-Core LEON3FT SPARC V8 + RTG4	Rad-hard	CubeSat, SmallSat	9	(22)
Argotec	OBC HACK	Quad-Core SPARC V8	Rad-hard + MIL + Automotive	NA	6	(23)
Resilient Computing	RadPC-SBC-001	RISC-V 32-Bit	COTS with SEE mitigation	CubeSat	8	(24)
Spacemanic	Eddie_OBC	MSP430FR5994IPN	COTS	Cubesat	9	(25)
	DeepThought_OBC	SAMV71Q21RT-H8X	COTS	Cubesat	9	(26)
Novo Space	SBC002AV	quad A53 + dual R5 (Xilinx Zynq Ultrascale+)	COTS	General Satellite	Ukn	(27)
	SBC003AV	Cortex-M3 (SmartFusion2)	COTS	General Satellite	Ukn	(28)
	GPU001AF	NVIDIA Jetson TX2i	COTS	General Satellite	Ukn	(29)



KP Labs	Antelope onboard computer	TT&C – RM57 Herkules microcontroller (Dual 300 MHz ARM Cortex-R5F with FPU in lock-step)  DPU – AMD Xilinx Zynq UltraScale+ MPSoC (ZU2EG, ZU3EG, ZU4EG, ZU5EG), Quad ARM Cortex-A53 CPU, Dual ARM Cortex-R5 in lock-step	COTS	CubeSat	6	(30)
	Leopard	AMD Xilinx Zynq UltraScale+ MPSoC (ZU6EG, ZU9EG, ZU15EG); Quad ARM Cortex-A53 CPU; Dual ARM Cortex-R5 in lock-step	COTS	CubeSat	6	(31)
	Lion	AMD Xilinx Kintex Ultrascale FPGA (KU035, KU060, KU095)	COTS	Micro and Small satellites	6	(32)
C3S Electronics Development LLC	OBC	32-bit ARM Cortex-M7	COTS	CubeSat	9	(33)
	IPC	Quad-core Cortex-A9	COTS	CubeSat	4	
EnduroSat	OBC	ARM Cortex-M7	COTS	CubeSats	9	(34)



### 8.3.3 Radiation-Hardened Processors

Several radiation-hardened embedded processors have recently become available. These are being used as the core processors for a variety of purposes including CDH. Some of these are the Vorago VA10820 (ARM M0) and the VA41620 and VA41630 (ARM M4); Cobham GR740 (quad core LEON4 SPARC V8); BAE 5545 quad core processor; and LS1043 quad processor. These have all been radiation tested to at least 50 kRad total ionizing dose.

### 8.3.4 Memory, Electronic Function Blocks, and Components

The range of onboard memory for small spacecraft is wide, typically starting around 32 kB and increasing with available technology. For CDH functions, onboard memory requires high reliability. A variety of different memory technologies have been developed for specific traits, including volatile memory, such as Static Random-Access Memory (SRAM) and Dynamic RAM (DRAM), Magnetoresistive RAM (MRAM), Ferro-Electric RAM (FERAM), Chalcogenide RAM (CRAM) and Phase Change Memory (PCM). SRAM is typically used due to price and availability, with numerous SRAM choices (up to 4M x 39 [20 MB]). There are many manufacturers that provide a variety of electronic components that are space-rated with high reliability. A chart comparing the various memory types and their performance is shown in table 8-2.

<b>Feature</b>	<b>SRAM</b>	<b>DRAM</b>	<b>Flash</b>	<b>MRAM</b>	<b>FERAM</b>	<b>CRAM/ PCM</b>
Non-volatile	No	No	Yes	Yes	Yes	Yes
Operating Voltage, $\pm 10\%$	2.5 – 5 V	1.35-3.3 V	3.3 & 5 V	3.3 V	3.3 V	3.3 V
Organization (bits/die)	512 k × 8 4M × 39	128 M × 8 1Gb × 8	16 M × 8; 4G × 8	2M × 8	16 k × 8	Unk
Data Retention (70°C)	N/A	N/A	10 years	10 years	10 years	10 years
Endurance (Erase/Write cycles)	Unlimited	Unlimited	1E5	1E13	1E13	1E13
Access Time	10-25 ns	25 ns	50 ns after page ready; 200 us write; 2 ms erase	300 ns	300 ns	100 ns
Radiation (TID)	50K - 1 Mrad	50 krad	30 krad	1 Mrad	1 Mrad	1 Mrad
Temperature Range	MIL-STD	Industrial	Commercial	MIL-STD	MIL-STD	MIL-STD
Power	500 mW	300 mW	30 mW	900 mW	270 mW	Unk
Package	4 MB-20 MB	128 MB 1GB	128MB – 4 GB	2 MB	1.5 MB (12 chip package)	Unk



### 8.3.5 Bus Electrical Interfaces

CubeSat class spacecraft continue to use interfaces that are common in the microcontroller or embedded systems world. Highly integrated systems, especially systems-on-chip (SoCs), FPGAs, and application-specific integrated circuits (ASICs), will typically provide several interfaces to accommodate a wide range of users and to ease the task of interfacing with peripheral devices and other controllers. FPGAs are commonly used for these interfaces because of their flexibility and ability to change interfaces as needed. Some of the most common bus electrical interfaces are listed below with applicable interface standards:

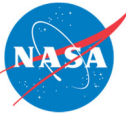
- Serial Communication Interfaces (SCI): RS-232, RS-422, RS-485 etc.
- Synchronous Serial Communication Interface: I2C, SPI, SSC and ESSI (Enhanced Synchronous Serial Interface)
- Multimedia Cards (SD Cards, Compact Flash, etc.)
- Networks: Ethernet, LonWorks, etc.
- Fieldbuses: CAN Bus, LIN-Bus, PROFIBUS, etc.
- Timers: PLL(s), Capture/Compare and Time Processing Units
- Discrete IO: General Purpose Input/Output (GPIO)
- Analog to Digital/Digital to Analog (ADC/DAC)
- Debugging: JTAG, ISP, ICSP, BDM Port, BITP, and DB9 ports
- SpaceWire: a standard for high-speed serial links and networks
- High-speed data: RapidIO, XAUI, SerDes and MGT protocols are common in routing large quantities of mission data in the gigabit per second speeds

### 8.3.6 Radiation Mitigation and Tolerance Schemes

Deep space and long-duration LEO missions compel developers to consider reliability requirements and possibly incorporate radiation-mitigation strategies into their respective spacecraft designs. CubeSats are often either composed of only COTS components or a hybrid combination of COTS and rad-hard and radiation-tolerant components. COTS components typically offer superior performance, energy efficiency, and affordability compared to their rad-hard alternatives; however, COTS devices tend to be highly susceptible to radiation. The advantages of COTS components have enabled low-cost CDH development, while also allowing developers to leverage start-of-the-art technologies in their designs. A hybrid design combines COTS and rad-hard components, such as COTS processor and memory with rad-hardened supporting electronics (e.g., EPS, watchdog, etc.), to maximize the benefits of both technologies. These designs may also incorporate radiation-mitigation techniques to further enhance overall system reliability.

For space applications, the effects of radiation on electronic devices can vary broadly (35). Radiation effects are often categorized into long-term cumulative effects and transient single-event effects (SEEs). Long-term effects include total ionizing dose (TID) and displacement damage dose (DDD). TID, measured in krad, is the ionizing radiation absorbed by the device material over time causing parametric or functional degradation of the device. DDD is the nonionizing damage caused by particle collisions with the device structure over time. SEEs occur when a single radiation particle strike deposits enough charge to cause an effect. SEEs can be destructive or nondestructive. Single-event upsets (SEUs) are nondestructive SEEs that can affect the logic state of a memory cell. Single-event latch-up (SEL) are destructive SEEs that manifest as parasitic structures in CMOS logic or bipolar transistor structures, potentially causing a high-current state.

Other CDH element areas of consideration include: memory, imaging, protection circuits (watchdog timers, communications watchdog timers, overcurrent protection, and power control),



memory protection (error-correction code memory and software error detection and correction), communication protection (several components), and parallel processing and voting.

#### **8.4 State-of-the-Art (TRL 5-9): Flight Software**

The FSW, at a fundamental level, communicates the instructions for the spacecraft to perform all operations necessary for the mission. These include all the science objectives as well as regular tasks (commands) to keep the spacecraft functioning and ensure the storage and communication of data (telemetry). The FSW is usually thought of as all the programs that run on the CDH avionics, but should also include all software running on the various subsystems and payload(s).

There are many factors in selecting a development environment and/or operating system for a space mission. A major factor is the amount of memory and computational resources. There are always financial and schedule concerns. Another factor is what past software an organization may have used and their experiences with that software. The maturity of the software and its availability for the target subsystem or payload are additional factors to be considered in the final selection.

FSW complexity can refer to the architecture design (e.g., the interactions between subsystems, especially for spacecraft autonomy) as well as the number of operations to be performed. The more software is required to do, the bigger the task and cost. This complexity (and the associated verification effort) is what primarily drives the cost and schedule for a program or mission. Required reliability and fault management can also increase complexity and cost, regardless of the size of the spacecraft. Changing requirements is also a huge factor, which may be mitigated by involving the software team early in the planning process.

With the increase in processing capability with CDH and other processors, more capable FSW has been enabled. Traditionally, larger spacecraft require rad-hard processors which have poor performance, while CubeSats and SmallSats can take more risks with COTS processors that offer substantially more performance. Several advances have increased the processing capabilities available for CubeSats. Low-power ARM-based processors and embedded COTS SoCs, as well as advances in radiation hardened processors, have brought similar processing capabilities down to the small size of CubeSats. All of this has resulted in increased demands and requirements for FSW.

Generally, CDH and other subsystems need to be able to supervise several inputs and outputs as well as process and store data within a fixed time-period. These all need to be performed in a reliable and predictable fashion throughout the lifetime of the mission. The needs of each mission can vary greatly, but basic deterministic and reliable processing is a fundamental requirement. The following are important when considering FSW design:

- Implication of CDH processors on FSW
- Frameworks
- Operating systems
- Software languages
- Mission operations and ground support suites
- Development environment, standards, and tools

##### **8.4.1 Implication of CDH Processors on FSW**

The processor and memory available on the CDH can put significant limitations on the FSW. For some of the smaller jobs, or to reduce electronic complexity, smaller processors are used (distributed processing). These have typically been thought of as embedded processors, with many of them containing dedicated memory. Modern integrated space avionics, including heterogeneous and mixed criticality architectures, also impact operational constructs and can



contribute to advanced configurations (such as multiple modular redundant systems architectures) which can allow advanced paradigms for radiation tolerance and system redundancies in critical small spacecraft missions.

#### **8.4.2 Frameworks**

In the context of SSA, a FSW framework can be described as a hierarchal architecture, sometimes referred to as a set of lego-like building block constructs, partitions, and functions. This emerging system-of-systems concept describes the large-scale integration of many independent, self-contained systems that work together to satisfy a global need. Examples of commonly used frameworks include:

- cFS (<https://cfs.gsfc.nasa.gov>)
- F' (<https://github.com/nasa/fprime>)
- NanoSat Mission Operations Framework (<https://nanosat-mo-framework.github.io/>)
- Spacecloud (<https://space-cloud.io/>)
- ROS (<https://www.ros.org/>)

#### **8.4.3 Operating Systems**

Operating systems manage computer hardware, software resources, and provide common services for computer programs. Examples of commonly used operating systems include:

- VxWorks
- RTEMS
- FreeRTOS
- Linux

#### **8.4.4 Software Languages**

System programming involves designing and writing computer programs with software languages that allow the computer hardware to interface with the programmer and the user, leading to the effective execution of application software on the computer system. State-of-the-art small spacecraft have used C, C++, Python, Arduino and other software languages.

#### **8.4.5 Mission Operations and Ground Support Suites**

Although not directly used on the spacecraft, mission operations and ground support suites must also use software and systems for testing, and to monitor, command, control, and communicate with the spacecraft, as well as display status and disseminate data across all aspects of a space mission (including spacecraft performance and procedures, systems health, science and technology data handling and management, and telemetry tracking and control). For smaller spacecraft and missions, it is usually best to use the same ground support software for mission operations, integration and testing, and development and testing. There are numerous open-source and proprietary tools and programs available for these activities. A small set of tools that have been used at NASA are described below. For more information, please refer to the Ground Data System and Mission Operations chapter.

#### **8.4.6 Development Environment, Standards, and Tools**

Development environment, standards, and tools are used to design, develop, validate, and operate small spacecraft missions, with adherence to accepted software and space mission standards. Examples of commonly used development tools include:

- Version control tools





- Auto-generation of software
- Simulations and simulators
- Software best practices and NPR7150

### **8.5 On the Horizon (TRL 1-4): Command and Data Handling**

Many CDH systems will continue to follow trends set for embedded systems. Short-duration missions in LEO will continue to take advantage of advances made by industry leaders who provide embedded systems, technologies, and components. In keeping with the low-cost, rapid development theme of CubeSat-based missions, many COTS solutions are available for spacecraft developers.

While traditional CDH processing needs are relatively stagnant, as small satellites are being targeted for flying increasingly data-heavy payloads (i.e., imaging systems) there is new interest in advanced onboard processing for mission data. Typically, these higher performance functions would be added as a separate payload processing element outside of the CDH function.

Next-generation SSA/PSA distributed avionics applications are integrating FPGA-based software-defined radios (SDRs) on small spacecraft (36). A SDR can transmit and receive in widely different radio protocols based on a modifiable, reconfigurable architecture, and is a flexible technology that can enable the design of an adaptive communications system. This can increase data throughput and enable software updates on-orbit, also known as re-programmability. Additional FPGA-based functional elements include imagers, AI/ML processors, and subsystem-integrated edge and cloud processors. The ability to reprogram sensors or instruments while on-orbit have benefited several CubeSat missions when instruments do not perform as anticipated, or when entering an extended mission phase that requires subsystems or instruments to be reprogrammed.

In keeping with trends seen in other disciplines and industries, the Industry 4.0 and “digitally managed everything” is absolutely of critical importance for technological and programmatic efficiencies in SSA systems development. Following are some modern tools, technologies, and approaches that should be considered when developing and deploying next-generation small spacecraft avionic systems:

- Artificial intelligence, machine learning, and machine vision
- Robotics and automation
- Model-based systems engineering
- Embedded systems / edge computing
- Internet-of-space-things
- Cloud computing
- Augmented reality/ virtual reality / mixed reality
- Software-defined-everything
- Advanced manufacturing
- Digital twin

### **8.6 On the Horizon (TRL 1-4): Flight Software**

FSW is key to mission success. The field of software is a very dynamic environment that is continuously evolving. The challenges with flight software usually remain the same regardless of the size of the spacecraft (CubeSat to SmallSat) and are related to the size and complexity of the endeavor. Overall, FSW can be known to cause scheduling issues and implementation issues, especially during integration and test. There is usually a temptation to add additional features,



and all these factors can drive up overall complexity of the FSW and increase risk to the mission as a whole.

It is essential that FSW be as simple as possible. It is critical to survey options and plan early in any FSW effort. Wherever possible, early development and testing should be performed. Efforts to add additional features should be looked at very critically with a strong effort to stick to the existing plan. With good planning and careful execution, a favorable outcome can be achieved. It is becoming more common to update software after the hardware is delivered (or even launched), and there are now software frameworks such as cFS that have features to enable software updates after deployment.

On the horizon FSW will soon include multicore processor operating systems and programming, as learning how to harness multicore processors differently than Microsoft Windows does will enable true real-time multiprocessing. On the horizon FSW will also include artificial intelligence (e.g., Nvidia); FSW for multicore, multiprocessor, and heterogeneous platforms (e.g., AMD-Xilinx Versal); and FSW (middleware) for constellations of SmallSats with resource management, scheduling and task assignment, and fault tolerance.

Spacecraft autonomy is an emerging capability and SmallSat designers have particular interest in the following characteristics for autonomous systems:

- Situational and self-awareness
- Reasoning and acting
- Collaboration and interaction
- Engineering and integrity

Spacecraft autonomy can be considered as a part of management, direction, and control for all subsystems and functions in a spacecraft. CDH takes input from, and provides direction to, all subsystems (ADCS, Power, Propulsion, Comm, vehicle health, etc.). Those subsystems may also have a degree of autonomy depending on the complexity of its local “smart subsystems” processor. The NASA 2020 Technology Roadmap defines autonomous systems as a cross-domain capability that enables the system to operate in a dynamic environment independent of external control (37).

Some autonomous systems now implement a heterogeneous architecture, meaning they contain multiple processors with varying levels of performance and capabilities. For instance, higher performance modules and components can be used for sophisticated data processing, AI and onboard computing for both spacecraft and mission performance optimization—as well as real-time adaptive analysis of science data—while lower performance onboard processors and FPGAs conduct the routine spacecraft operations functions and interact with the subsystems which also may include distributed performance cascades.

## 8.7 Summary

Space applications now require considerable autonomy, precision, and robustness, and are refining technologies for such operations as on-orbit servicing, relative and absolute navigation, inter-satellite communication, and formation flying. An exciting trend is that small spacecraft missions are becoming more complex as these platforms are now being used for lunar and deep space science and exploration missions. Small spacecraft technology is expanding to meet the needs of increasing small spacecraft mission complexity. This has accelerated over the past few years to achieve the next gen goals of using small spacecraft to collect important science in deep space, and mitigate risk for larger, more complex mission-critical situations. In parallel, spacecraft electronics have matured with higher performance and reliability, and with miniaturized components that meet the growing needs of these now very capable spacecraft.



The 2022 Small Spacecraft Avionics chapter has been updated with a broader, interrelated framework, where CDH, FSW, and smart payloads are not just independent space platform subsystems but are part of an integrated avionics ecosystem which includes all electronic elements of a space platform, now primarily digitally based and or managed. Also, SSA should not be considered as an isolated spaceflight technology component, but rather as a core digital engineering technology emphasis area, capable of taking advantage of and integrating products, processes, and technologies from other disciplines. To continue to be relevant and efficient, the SSA communities must remain cognizant and receptive of the continuously evolving nature of the digital based Industry 4.0 technology revolution now being evidenced in other related and/or associated vertical disciplines and solutions.

For feedback solicitation, please email: [arc-sst-soa@mail.nasa.gov](mailto:arc-sst-soa@mail.nasa.gov). Please include a business email for further contact.

## References

- (1) GomSpace. "NanoMind A3200," Technical Datasheet. [Online] 2019. Available at: <https://gomspace.com/shop/subsystems/command-and-data-handling/nanomind-a3200.aspx>
- (2) ISISPACE. "ISIS On board computer," Technical Datasheet. [Online] 2019. Available at: <https://www.isispace.nl/wp-content/uploads/2016/02/IOBC-Brochure-web-compressed.pdf>.
- (3) Pumpkin Space Systems. "Processor-specific CubeSat Kit Components," Pumpkin Products/Store. [Online] 2020. Available at: [https://www.pumpkinspace.com/store/c19/Processor-specific\\_CubeSat\\_Kit%E2%84%A2\\_Components.html](https://www.pumpkinspace.com/store/c19/Processor-specific_CubeSat_Kit%E2%84%A2_Components.html).
- (4) Xiphos. "Q7S Specifications," Technical Datasheet. [Online] 2020. Available at: <http://xiphos.com/wp-content/uploads/2015/06/XTI-2001-2020-e-Q7S-Spec-Sheet.pdf>.
- (5) Xiphos. Q8S SPECIFICATIONS - Datasheet. [Online] 2020. Available at: <http://xiphos.com/wp-content/uploads/2020/06/XTI-2001-2025-f-Q8S-Rev-B-Spec-Sheet-1.pdf>.
- (6) BAE Systems. "RAD750 3U CompactPCI single-board computer." BAE Systems: Space product literature. [Online] 2008. Available at: <https://www.baesystems.com/en-us/our-company/inc-businesses/electronic-systems/product-sites/space-products-and-processing/radiation-hardened-electronics>.
- (7) BAE Systems. "RAD5545 Space VPX single-board computer." BAE Systems: Space products literature. [Online] 2017. Available at: <https://www.baesystems.com/en-us/our-company/inc-businesses/electronic-systems/product-sites/space-products-and-processing/radiation-hardened-electronics>.
- (8) AAC Clyde Space. "Command & Data Handling KRYTEN-M3," Technical Datasheet. [Online] 2020. Available at: [https://www.aac-clyde.space/assets/000/000/179/AAC\\_DataSheet\\_Kryten\\_original.pdf?1600342763](https://www.aac-clyde.space/assets/000/000/179/AAC_DataSheet_Kryten_original.pdf?1600342763).
- (9) AAC Clyde Space. "Command & Data Handling Sirius OBC LEON3FT," Technical Datasheet. [Online] 2020. Available at: [https://www.aac-clyde.space/assets/000/000/181/AAC\\_DataSheet\\_Sirius\\_OBC\\_-\\_updated\\_tables\\_original.pdf?1599046187](https://www.aac-clyde.space/assets/000/000/181/AAC_DataSheet_Sirius_OBC_-_updated_tables_original.pdf?1599046187).
- (10) Innoflight. "CFC-300: Compact Flight Computer," Technical Datasheet. [Online] 2020. Available at: <https://www.innoflight.com/product-overview/cfcs/cfc-300/>.



- (11) Innoflight. "CFC-400: Compact Flight Computer," Technical Datasheet. [Online] 2020. Available at: <https://www.innoflight.com/product-overview/cfcs/cfc-400/>.
- (12) Innoflight. "CFC-500: Compact On-Board Computer," Technical Datasheet. [Online] 2020. Available at: <https://www.innoflight.com/product-overview/cfcs/cfc-500/>.
- (13) Space Micro. "CubeSat Space Processor (CSP)," Technical Datasheets. [Online] 2019. Available at: <https://www.spacemicro.com/assets/datasheets/digital/slices/CSP.pdf>.
- (14) Nanoavionics. "CubeSat On-Board Computer - Main Bus Unit SatBus 3C2," Technical Datasheet. [Online] 2020. Available at: <https://nanoavionics.com/CubeSat-components/CubeSat-on-board-computer-main-bus-unit-satbus-3c2/>.
- (15) Moog. "Radiation Tolerant, 75GLOP 3U SPaceVPX GPU Single Board Computer," Technical Datasheet. [Online] 2020. Available at: <https://www.moog.com/content/dam/moog/literature/sdg/space/avionics/Moog-Rad-Tolerant-75GFLOP-3U-SpaceVPX-GPU-Single-Board-Computer-Datasheet.pdf>
- (16) Moog. "BRE440 RADHARD CPU," Technical Datasheet. [Online] 2018. Available at: <https://www.moog.com/content/dam/moog/literature/sdg/space/avionics/moog-BRE440-RADHardCPU-Datasheet.pdf>
- (17) SEAKR. Commercial Products. SEAKR: Catalog. [Online] 2020. Available at: <https://www.seakr.com/catalog/>
- (18) Unibap. "iX10-100 SpaceCloud solution," [Online] Available at: <https://unibap.com/en/our-offer/space/spacecloud-solutions/ix10100/>
- (19) Unibap. "iX5-100 SpaceCloud solution," [Online] Available at: <https://unibap.com/en/our-offer/space/spacecloud-solutions/ix5100/>
- (20) Unibap. "e20xx/e21xx Qseven Compute Product," Technical Datasheet. [Online]. Available at: [https://unibap.com/wp-content/uploads/2021/06/1004001-unibap-information-sheet-on-unibap-e2000\\_e2100-modules.pdf](https://unibap.com/wp-content/uploads/2021/06/1004001-unibap-information-sheet-on-unibap-e2000_e2100-modules.pdf)
- (21) Nara Space Technology, Inc. "Nara Space OBC Datasheet," Technical Datasheet, 2022.
- (22) Argotec. "FERMI: Deep Space On-Board Computer," Technical Datasheet. [Online] Available at: [https://www.argotecgroup.com/wp-content/uploads/2022/03/Argotec\\_FERMI\\_scheda\\_prodotto.pdf](https://www.argotecgroup.com/wp-content/uploads/2022/03/Argotec_FERMI_scheda_prodotto.pdf)
- (23) Argotec. "Hack: High-Performance Modular On-Board Computer," Technical Datasheet. [Online] Available at: [https://www.argotecgroup.com/wp-content/uploads/2022/03/Argotec\\_HACK\\_scheda\\_prodotto.pdf](https://www.argotecgroup.com/wp-content/uploads/2022/03/Argotec_HACK_scheda_prodotto.pdf)
- (24) Resilient Computing. "Technology: RadPC - Radiation Tolerant Computing." [Online] Available at: <https://resilient-computing.com/technology>
- (25) Spacemanic. "Eddie: The computer, SM-OBC-MSP430," Technical Datasheet. [Online] Available at: [https://www.spacemanic.com/files/datasheet/datasheet-OBC\\_Eddie.pdf](https://www.spacemanic.com/files/datasheet/datasheet-OBC_Eddie.pdf)
- (26) Spacemanic. "Deep Thought Onboard Computer, OBC-SM-DT-SAMV71," Technical Datasheet. [Online] Available at: <https://www.spacemanic.com/files/datasheet/datasheet-OBC-DT.pdf>
- (27) Novo Space. "SBC002AV," [Online] Available at: <https://www.novo.space/products/sbc002av/>
- (28) Novo Space. "SBC003AV," [Online] Available at: <https://www.novo.space/products/sbc003av/>



- (29) Novo Space. "GPU001AF," [Online] Available at: <https://www.novo.space/products/gpu001af/>
- (30) KP Labs. "Antelope," Technical Datasheet. [Online] Available at: <https://kplabs.space/wp-content/uploads/Antelope-technical-sheet.pdf>
- (31) KP Labs. "Leopard," Technical Datasheet. [Online] Available at: <https://kplabs.space/wp-content/uploads/Leopard-technical-sheet.pdf>
- (32) KP Labs. "Lion," Technical Datasheet. [Online] Available at: <https://kplabs.space/wp-content/uploads/Lion-technical-sheet.pdf>
- (33) C3S Electronics Development LLC. "ON-BOARD COMPUTER (OBC)," Technical Datasheet. [Online] Available at: [https://c3s.hu/wp-content/uploads/2022/01/C3S\\_OBC\\_datasheet.pdf](https://c3s.hu/wp-content/uploads/2022/01/C3S_OBC_datasheet.pdf)
- (34) EndroSat. "Onboard Computer - OBC," [Online] Available at: <https://www.endurosat.com/cubesat-store/cubesat-obc/onboard-computer-obc/>
- (35) National Academies of Sciences, Engineering, and Medicine. 2018. Testing at the Speed of Light: The State of U.S. Electronic Parts Space Radiation Testing Infrastructure. Washington, DC: The National Academies Press.
- (36) M. Wirthlin, "High-Reliability FPGA-Based Systems: Space, High-Energy Physics, and Beyond," in Proceedings of the IEEE, vol. 103, no. 3, pp. 379-389, March 2015.
- (37) NASA. 2020 Technology Taxonomy. [Online] Available at: [https://www.nasa.gov/sites/default/files/atoms/files/2020\\_nasa\\_technology\\_taxonomy.pdf](https://www.nasa.gov/sites/default/files/atoms/files/2020_nasa_technology_taxonomy.pdf)



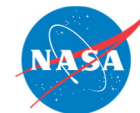
## Chapter Contents

Chapter Glossary .....	ii
9.0 Communications.....	227
9.1 Introduction .....	227
9.2 Radio Frequency Communications .....	228
9.2.1 Frequency Bands .....	228
9.2.2 System Architecture .....	229
9.2.3 Major Components in Smallsat Communication Systems .....	230
9.2.4 Design Considerations.....	231
9.2.5 Policies and Licensing .....	231
9.2.6 Encryption.....	232
9.2.7 Antennas .....	233
9.2.8 Radios .....	234
9.2.9 On the Horizon RF Communications .....	234
9.3 Free Space Optical Communications.....	242
9.3.1 System Architecture .....	243
9.3.2 Optical Ground Stations.....	243
9.3.3 Design Considerations.....	244
9.3.4 Policies and Licensing .....	245
9.3.5 Mission Examples.....	245
9.3.6 Future Technologies.....	247
9.4 Summary.....	249



## Chapter Glossary

(ADCS)	Attitude Determination and Control System
(BPF)	BandPass Filters
(CDH)	Command and Data Handling
(COTS)	Commercial-off-the-Shelf
(DORA)	Deployable Optical Receiver Aperture
(DLR)	German Aerospace Center
(DSN)	Deep Space Network
(DSP)	Digital Signal Processing
(DVB-S2)	Digital Video Broadcast Satellite Second Generation
(FCC)	Federal Communications Commission
(FIPS)	Federal Information Processing Standard
(FPGAs)	Field Programmable Gate Arrays
(FSM)	Fine-steering Mirror
(FSO)	Free Space Optical
(IARU)	International Amateur Radio Union
(IEEE)	Institute of Electrical and Electronics Engineers
(ISARA)	Integrated Solar Array and Reflectarray Antenna
(ISM)	Industrial, Scientific, and Medical
(ISOC)	Inter-spacecraft Optical Communicator
(ISS)	International Space Station
(JAXA)	Japanese Aerospace Exploration Agency
(JPL)	Jet Propulsion Laboratory
(LADEE)	Lunar Atmosphere and Dust Environment Explorer
(Lasercom)	Laser Communications
(LCH)	Laser ClearingHouse
(LCT)	Laser Communication Terminals
(LDPC)	Low-Density Parity-check Code
(LLCD)	Lunar Laser Communications Demonstration
(LNA)	Low Noise Amplifier
(LSRB)	Laser Safety Review Board
(MA)	Multiple Access
(MarCO)	Mars Cube One
(MEMS)	Micro-Electro-Mechanical Systems



(MRR)	Modulating Retro-Reflector
(NEN)	Near Earth Network
(NICT)	National Institute of Information and Communications Technology
(NOAA)	National Oceanic and Atmospheric Administration
(NPR)	NASA Procedural Requirements
(NTIA)	National Telecommunications and Information Administration
(OCSD)	Optical Communication and Sensor Demonstration
(OCTL)	Optical Communication Telescope Laboratory
(OSIRIS)	Optical Space Infrared Downlink System
(PAT)	Pointing, Acquisition, and Tracking
(RF)	Radio Frequency
(SBIR)	Small Business Innovative Research
(SCaN)	Space Communications and Navigation
(SDR)	Software Defined Radios
(SME)	Subject Matter Expert
(SNR)	Signal-to-Noise Ratio
(SOTA)	Small Optical Transponder
(SWaP)	Size, Weight, and Power
(TDRS)	Tracking and Data Relay Satellite
(TMA)	Technology Maturity Assessments
(TRL)	Technology Readiness Levels
(TT&C)	Tracking, Telemetry & Command
(VSOTA)	Very Small Optical Transponder
(WFF)	Wallops Flight Facility



## 9.0 Communications

### 9.1 Introduction

The communication system is an essential part of a spacecraft. For most missions the communication system enables the spacecraft to transmit data and telemetry to Earth, receive commands from Earth, and relay information from one spacecraft to another. A communications system consists of the ground segment: one or more ground stations located on Earth, and the space segment: one or more spacecraft and their respective communication payloads. The three functions of a communications system are receiving commands from Earth (uplink), transmitting data down to Earth (downlink) and transmitting or receiving information from another satellite (crosslink or inter-satellite link) (figure 9.1). There are two types of communication systems: radio frequency (RF) and free space optical (FSO), FSO is also referred to as laser communications (lasercom).

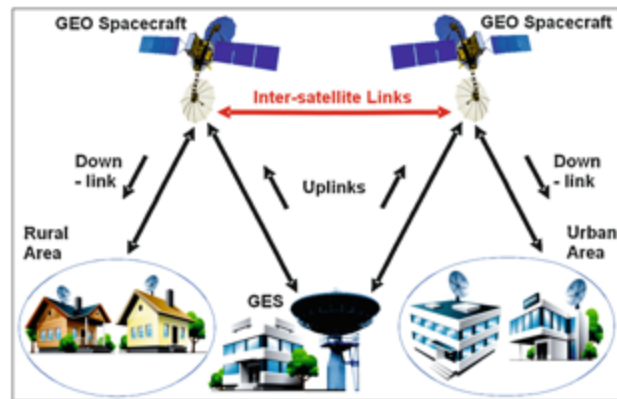


Figure 9.1: Satellite uplink, downlink, and crosslink. Credit: D. Stojce (2019).

Most spacecraft communications systems are radio frequency based. They typically operate within the designated Institute of Electrical and Electronics Engineers (IEEE) radio bands of 300 MHz to 40 GHz. A RF system communicates by sending data using electromagnetic waves to and from antennas. Information is modulated onto radio frequency electromagnetic waves and sent over a channel, through the atmosphere or space, to the receiving system where it is demodulated (figure 9.2).

Although RF systems are typically used for low-rate space communication, recent developments in FSO communications have made it a compelling alternative to RF systems, particularly for high-rate communication. FSO systems consist of a transmitting terminal and receiving terminal. Like an RF system, information is modulated onto electromagnetic waves (at optical frequencies) and sent over a channel to the receiving system. FSO links operate at a much higher frequency than

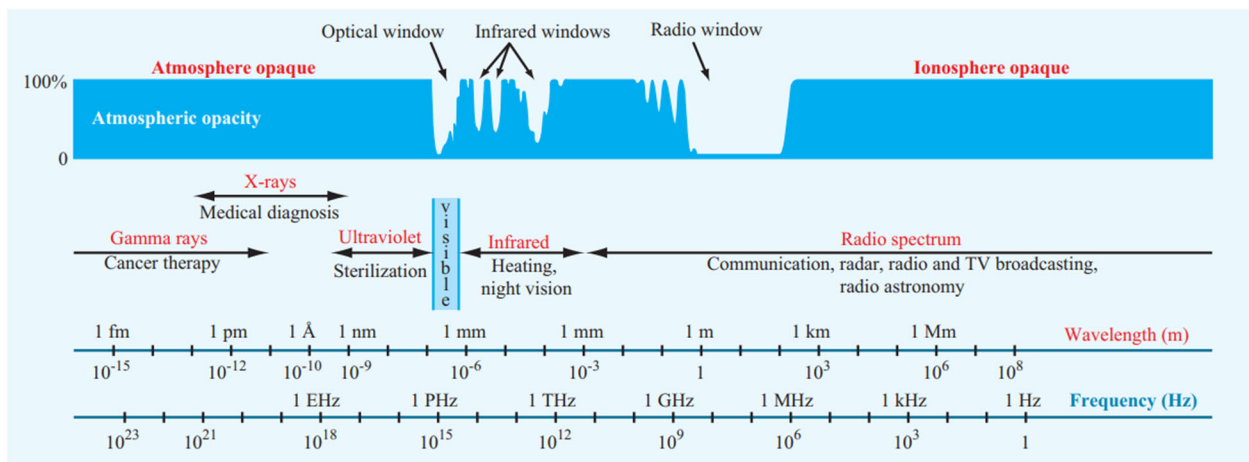
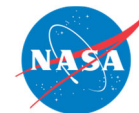


Figure 9.2: Atmospheric opacity of the electromagnetic wave spectrum with the infrared and radio windows used by spacecraft for communication. Credit: Microwave Radar and Radiometric Remote Sensing by Ulaby and Long.



RF links, generally at near-infrared bands (e.g., 1064 nm or 1550 nm). Visible light is often not used due to eye safety concerns for technicians at the terminals. The use of higher frequencies and wider bandwidths can support higher data rates, but the shorter wavelengths also result in narrower beamwidths which require pointing your communication terminal both more accurately and precisely.

This chapter organizes the state-of-the-art in small spacecraft communications technologies into two main categories: RF and FSO. Tables at the end of each section list hardware options for RF and developing FSO technologies for mission designers to consider.

This chapter is a survey of small spacecraft communications technologies as discussed in open literature and does not endeavor to be an original source. This chapter only considers literature in the public domain to identify and classify devices. Commonly used sources for data include manufacturer datasheets, press releases, conference papers, journal papers, public filings with government agencies, and news articles. There is no intention of mentioning certain companies and omitting others based on their technologies or relationship with NASA.

## 9.2 Radio Frequency Communications

A radio communication system includes a radio transmitter, a free space communication channel, and a radio receiver. At the top level, a radio transmitter system consists of a data interface, modulator, power amplifier, and an antenna. The transmitter system uses the modulator to encode digital data onto a high frequency electromagnetic wave. The power amplifier then increases the output RF power of the transmitted signal to be sent through free space to the receiver using the transmit antenna.

The radio receiver system uses a receiving antenna, low noise amplifier, and demodulator to produce digital data output from the received signal. The receiving antenna collects the electromagnetic waves and routes the signal to the receiver, which then demodulates the wave and converts the electrical signals back into the original digital message. Low noise amplifiers are sometimes employed to minimize thermal noise in certain frequency bands and/or increase the received signal strength. In many cases, the functions of the modulator and demodulator are combined into a radio transceiver that can both send and receive RF signals.

Radio frequency communications for spacecraft are conducted between 30 MHz and 60 GHz. The lower frequency bands (up to S-band) are typically more mature for SmallSat use, however extensive use of these bands has led to crowding and challenges acquiring licensing. Higher frequencies offer a better ratio of gain-to-aperture-size, but this is offset by the increased atmospheric attenuation at those frequencies and the higher free space loss that is directly proportional to the square of the frequency.

### 9.2.1 Frequency Bands

Satellite communications are conducted over a wide range of frequency bands. The typical bands considered for small satellites are UHF, S, X, and Ka. The most mature bands used for CubeSat communication are VHF and UHF frequencies. There has been a shift in recent years towards S and X, with Ka-band also being used for recent & future small satellite communications. The move to higher frequency bands has been driven by a need for higher data rates. At the higher frequencies, there is generally greater atmospheric and rain attenuation

<b>Band</b>	<b>Frequency</b>
VHF	30 to 300 MHz
UHF	300 to 1000 MHz
L	1 to 2 GHz
S	2 to 4 GHz
C	4 to 8 GHz
X	8 to 12 GHz
Ku	12 to 18 GHz
K	18 to 27 GHz
Ka	27 to 40 GHz
V	40 to 75 GHz



adding to increased free space loss. This needs to be compensated for with higher power transmission and/or high gain antennas with narrower beamwidths. Moving to higher-gain antennas increases the pointing accuracy required for closing the link. See table 9-1 for a list of RF bands.

NASA spacecraft, which use the government bands of S-band, X-band and Ka-band, may use the NASA Near Space Network (NSN). The primary frequency bands of S, X, and Ka are more advantageous than using the UHF band, which has a higher probability of local interference. Satellite Tracking, Telemetry & Command (TT&C) is typically conducted over S-band. Non-NASA spacecraft have access to a wide variety of ground system options ranging from do-it-yourself to pay-per-pass services.

In L-band, CubeSats can take advantage of legacy communications networks such as Globalstar and Iridium by using network-specific transponders to relay information to and from Earth. These networks remove dependence on dedicated ground station equipment. However, they can only be used at orbital altitudes below the communication constellation and require experimental frequency authorization.

Ku-, K-, and Ka-band communication systems are the state-of-the-art for large spacecraft, especially in spacecraft-to-spacecraft communications, but they are still young technologies in the CubeSat world. They are becoming more attractive to SmallSat designers as the lower frequencies become more congested. At the higher frequencies, rain fade becomes a significant problem for communications between a spacecraft and Earth (1). Nonetheless, the benefits of operating at higher frequencies have justified further research by both industry and government alike. At JPL, the Integrated Solar Array and Reflectarray Antenna (ISARA) mission demonstrated high bandwidth Ka-band CubeSat communications with over 100 Mbps downlink rate (2). The back of the 3U CubeSat was fitted with a high gain reflectarray antenna integrated into an existing solar array. The successful demonstration of the reflectarray on ISARA became the basis for the Mars Cube One (MarCO) mission to Mars. The MarCO mission uses two twin CubeSats for a communications relay between the InSight lander and Earth. Using a X-band reflectarray they were able to successfully complete their mission (3). Another mission to use Ka-band for DTE communications was the Kepler telescope, launched in 2009. With future missions being increasingly data hungry, we are likely to see a shift towards Ka-band and, possibly, even higher frequencies.

CubeSats have also used the unlicensed Industrial, Scientific, and Medical (ISM) bands for communications. The Ames TechEdSat team has successfully demonstrated WiFi to downlink data at 1 Mbps. Notably, a group at Singapore's Nanyang Technological University used a 2.4 GHz ZigBee radio on its VELOX-I mission to demonstrate commercial-off-the-shelf (COTS) land-based wireless systems for inter-satellite communication (4). Similarly, current investigations are looking at using wireless COTS products, such as Bluetooth-compatible hardware, for inter-satellite communications (5).

### **9.2.2 System Architecture**

A small satellite RF communications system consists of a transceiver comprised of a radio, an amplifier, and an antenna. Radios receive a message from the Command and Data Handling (CDH) subsystem, then produce and modulate an electromagnetic wave to create a signal. They are responsible for generating the signal and modulating or demodulating it. The radio is also where coding may be added to the signal. Channel coding is added to provide data error detection and correction capabilities, which ensures reliable communication under the conditions imposed by the satellite transmission path. From Shannon's Equation (6), it is known that the information capacity of a channel is related to its bandwidth and signal-to-noise ratio (SNR). The channel

capacity (information flow) can be increased by increasing the SNR or the bandwidth, and many modulation and coding schemes make effective use of this tradeoff.

Radios offer some power amplification, but often the signals from small satellites require a greater boost. The power amplifier will take the signal from the radio and increase the RF output power before sending it to the transmit antenna. On the receive side, a low noise amplifier will take the weak signal from the receive antenna and amplify it while minimizing thermal noise. A bandpass filter might be used before the LNA to reject undesired frequencies. The radio will then be able to process the stronger signal with higher accuracy. In RF communications the role of the antenna is to increase and focus the strength of the signal in a specific direction. The digital message encoded on the RF carrier signal will be sent to and from the antennas of each system. See figure 9.3 for an example transmit and receive block diagram.

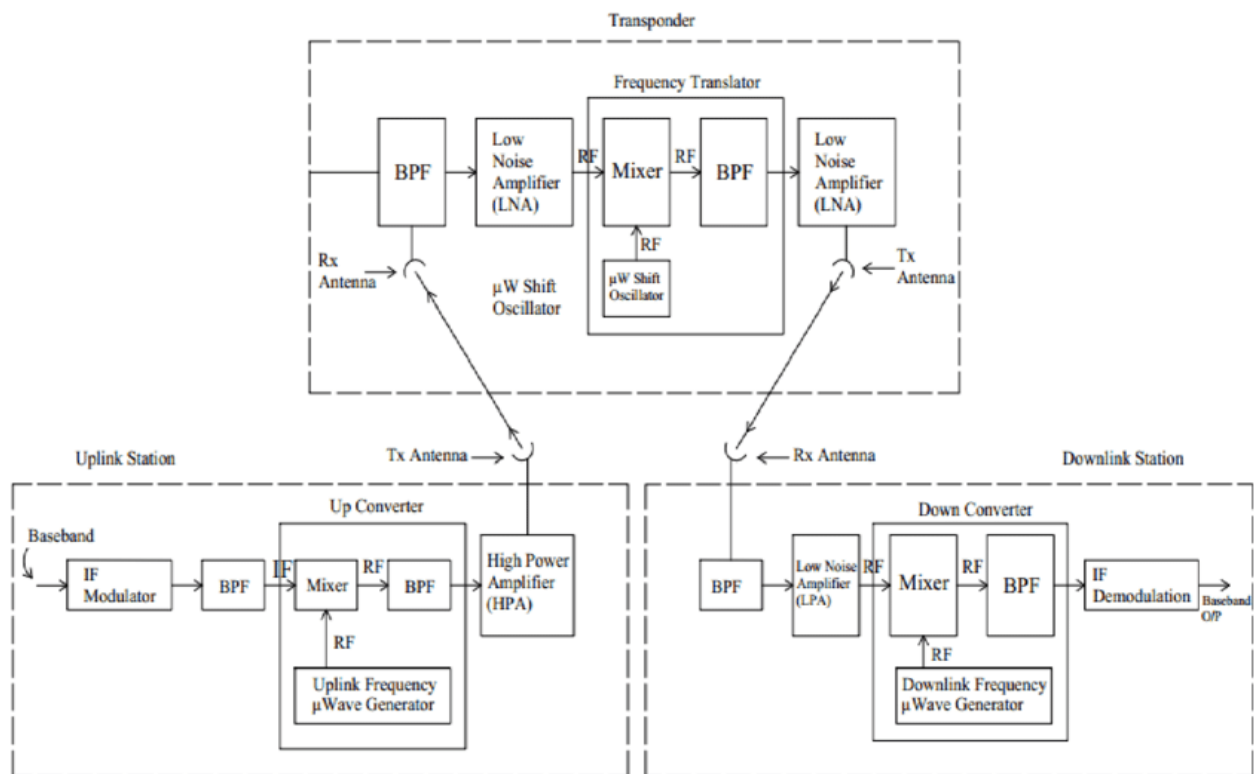


Figure 9.3: Transmit and receive block diagram. Credit: Karim et al. (2018). <http://creativecommons.org/licenses/by/4.0/>

### 9.2.3 Major Components in Smallsat Communication Systems

- Radio or Modulator/Demodulator: on the transmit side it produces, modulates, codes, and amplifies an electromagnetic wave to create a signal. Adds modulation and coding as needed. As a receiver it decodes and demodulates received signals.
- Mixers: RF mixers are used in communications systems to change the frequency of the signal. If the frequency generated by the radio is not the desired transmit frequency, then an upconverter will convert the signal to a higher frequency for transmit. Similarly, the downconverter will down convert a receive frequency to a lower one for processing.
- Filters: bandpass filters are used to reject undesired frequencies, typically before the LNA or downconverter.



- **Amplifier:** a power or gain amplifier is required for a transmit system. A low noise amplifier (LNA) is required for a receive system. LNAs, in addition to amplifying the (low power) received signal, serve to minimize the system noise temperature.
- **Antenna:** increases the strength of a signal in a specific direction, relative to the same signal strength without directionality. Transmits signals fed to it by a transmitter and receives signals propagated across free space. Antennas can be low-gain & omni-directional with a broad beam, or high-gain & directional with a narrow beam.
- **Encryption:** a cryptographic unit is an integrated encryptor/decryptor device that provides secure uplink, downlink, or crosslink for satellite communication links. Most small satellite designers will not require a cryptographic payload unit based on their threat level and may be able to use the communications radio for simple encryption schemes.
- **Spread-spectrum communication** applies a known frequency spreading function to the signal, which helps reduce interference from other transmitters, and provides more secure communications; as such, it is often used for multi-way communication networks. For example, the NASA Tracking and Data Relay Satellite (TDRS) multiple-access mode requires spread spectrum signals to support multiple simultaneous communication links.

#### 9.2.4 Design Considerations

The communications subsystem is an essential part of every spacecraft. It is required to transmit important health and telemetry data down to Earth, as well as receive commands from ground operators. Additionally, the communications system is critical to transporting mission data back to Earth. As with all spacecraft subsystems, there are power and mass constraints placed on the comm system. Based on these restrictions several trade studies need to be performed to choose the optimal design.

When designing a RF comm system, the first trades performed are for data rate, power consumption, and total mass. For example, a mission with high data rate needs would select a high frequency such as X-band for downlink and a directional high-gain antenna. Based on the ground station locations available, engineers would perform link budget analyses to determine the minimum power needed for a specific ground station antenna. This analysis would factor in rain and atmospheric attenuation, as well as modulation and coding. A few different link budget trades will be run, varying antenna size, RF output power and data rate. Each link will return a different margin of decibels, representing the reliability of the system. The engineers will proceed to calculate the final mass and power for each configuration. The mission designer will have a limit on mass and power constraints for the communications subsystem. Each configuration traded will compare data rate, power, and mass. A high data rate downlink may cost a high amount of mass for the antenna and power for the amplifier and radio. Conversely, a low-power, low-mass system may have a lower data rate.

Another factor that is considered in the design phase is pointing. Depending on the orbit of the satellite and whether the link is Uplink/Downlink, or Crosslink, the system may have a specific pointing requirement. Large satellites frequently use gimbals--platforms that can pivot to point their antennas. The addition of a gimbal will increase the overall mass and power draws of the system. CubeSats frequently trade high-gain antennas for low-gain, omni-directional ones to maintain the link regardless of directionality. CubeSats may also change their attitude to point a body-mounted antenna, rather than use a gimbal.

#### 9.2.5 Policies and Licensing

Any non-Federal US spacecraft with a transmitter must be licensed by the Federal Communications Commission (FCC). The types of RF licenses used by small satellites are: Amateur (FCC Part 97) and Experimental (FCC Part 5) (7). An amateur license type of



authorization is limited to hobbyists and non-profit use and comes with many FCC restrictions. Experimental Part 5 licenses are commonly used for university CubeSats and can be granted for a CubeSat operating in the amateur band (A SmallSat or SmallSat constellation can also apply under provisions of Part 25). A spacecraft with any sort of remote sensing capability must contact the National Oceanic and Atmospheric Administration (NOAA) to find out if a NOAA license is required. A NOAA license is not an RF license and conveys no authority for the radiation of RF energy for communication. For government missions the National Telecommunications and Information Administration (NTIA) is the licensing authority.

For Amateur licensing, there must be an FCC licensed amateur radio control operator. Downlink telemetry and communications cannot be obscured (encrypted). Use of science gathered via amateur radio downlink for profit (“pecuniary interest”) is prohibited. Frequency “assignment” in the amateur-satellite allocations requires coordination, a process administered by the International Amateur Radio Union (IARU) (8).

In 2018, the FCC adopted a Notice of Proposed Rulemaking to develop a new authorization process tailored specifically to small satellite operations, keeping in mind efficient use of spectrum and mitigation of orbital debris. Small satellites that would qualify for the new rules include those with 10 or lesser number of satellites under a single license. All individual satellites will have to be 10 cm or larger in the smallest dimension and weigh less than 180 kg. The maximum in-orbit lifetime of each individual satellite will be six years, including de-orbiting time, and they would have to be deployed under 600 km altitude. Each satellite will have a unique telemetry marker for tracking and will not release any debris (9).

### **9.2.6 Encryption**

Encryption is the process of encoding information to conceal it from outside actors. Small satellites can use a cryptographic unit to encrypt or decrypt data prior to transmission. When data is being prepared for transmission, it is broken up into packets. These packets are then scrambled according to the encryption scheme being used. An encryption scheme uses an encryption key generated by an algorithm to encode the data. The authorized receiver of the encrypted data will be able to decrypt the message using the appropriate key. Without the authorized key, decrypting the data will be extremely difficult.

With the increased proliferation of small satellites in low-Earth orbit comes an increase in vulnerabilities. Many SmallSats are comprised of COTS hardware and/or open-source software. While this strategy allows for a more flexible design approach, adversaries can gain insight into the design. Additionally, the improvement in propulsion technology for small satellites creates a potential collision threat for other low-Earth orbit spacecraft. Encryption of data in transit prevents other actors from commanding satellites or intercepting transmissions.

NASA requires any of its propulsive spacecraft within 2 million kilometers of Earth to protect their command uplink with encryption that is compliant with Level 1 of the Federal Information Processing Standard (FIPS) 140-3 (10). The FCC has also considered requiring encryption on the telemetry, tracking, and command communications as well as mission data for propulsive spacecraft, but decided not to incorporate a specific requirement at this time. A satellite with an amateur license cannot encrypt transmissions in any way and must consist of open information. The eligibility rules are listed in 47 CFR Part 97 (11).

### 9.2.7 Antennas

Antennas are used for propagating data through free space using electromagnetic waves. RF antennas are typically sized for their respective frequencies. This means that antennas are often chosen or designed specifically for their mission. COTS antennas are available for SmallSats and can be built to order. For missions that don't have high data rate requirements, a simple patch or monopole antenna with low gain and efficiency will suffice. Due to their low directionality, these antennas can generally maintain a communication link even when the spacecraft is tumbling, which is advantageous for CubeSats lacking good attitude and accurate pointing control. New developments in antenna design have put technologies like the deployable reflector antenna, reflectarray, and passive or active array antennas on the horizon for small satellites. Please see table 9-3 for information on commercially available antennas for SmallSat/CubeSats.

There are two primary classifications of antenna: fixed or deployable. Fixed antennas do not require any power or triggering mechanisms. They remain stationary in the position that they are attached to the spacecraft. This includes patch antennas, array antennas, monopole antennas, omni-directional antennas, and horn antennas (see figure 9.4). Deployable antennas require power to deploy and use mechanisms to configure into their final position. This includes whip antennas, parabolic reflectors, reflectarrays, helical and turnstile antennas (see figure 9.5).

A communications link is often characterized by the frequency and data rate. The antenna is a key design decision for meeting data rate objectives by increasing link margin. Increasing the aperture or diameter of an antenna increases the link margin, which can allow designers to increase the data rate of the system or reduce the necessary transmit power.

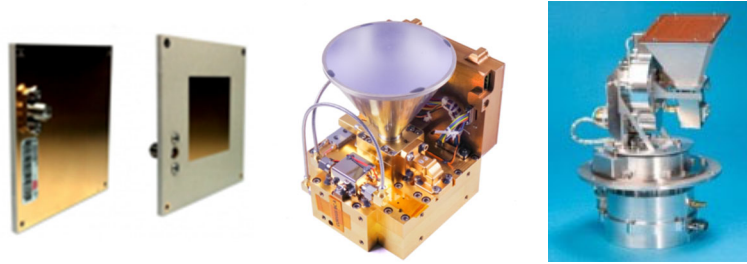


Figure 9.4: (from left to right) CubeSat-compatible S-band patch antenna (IQ Wireless), X-band high-gain antenna and pointing mechanism (Surrey Satellite Technology, Ltd.), and Ka-band transmitter with a horn antenna (Astro Digital).

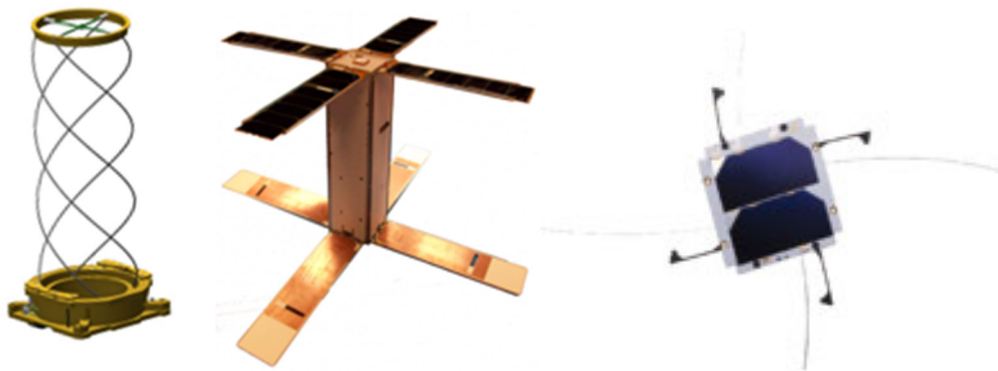


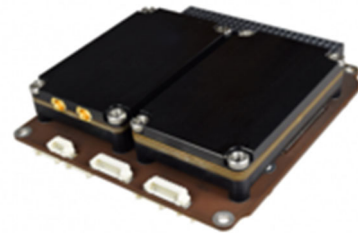
Figure 9.5: (from left to right) Example of deployable quadrifilar helical antenna (Helical Communication Technologies), SNaP spacecraft with Haigh-Farr's deployable UHF Crossed Dipole antenna (Space Missile and Defense Command), and EnduroSat UHF antenna with EnduroSat solar panels (EnduroSat).



### 9.2.8 Radios

Radios for SmallSat downlink are transceivers (transmitter and receiver in one). Transceivers convert digital information into an analog RF signal using a variety of modulation and coding schemes. Radios for TT&C are designed to be low data-rate, with high reliability and only need to transmit health data and receive commands. Traditional radios may be locked to a single frequency band and modulation/coding scheme based on their design and build. Software defined radios (SDR) have some or all of the radio's functions implemented in Digital Signal Processing (DSP) software rather than hardware, see figure 9.6 for an example of an SDR. Furthermore, spacecraft teams can change such characteristics in-flight by uploading new settings from the ground. By using Field Programmable Gate Arrays (FPGAs), SDRs have great flexibility that allows them to be used with multiple bands, filtering, adaptive modulation, and coding schemes, without much (if any) change to hardware (12). SDRs are especially attractive for use on CubeSats, as they are becoming increasingly small and efficient as electronics become smaller and require less power. NASA has been operating the Space Communications and Navigation (SCaN) Testbed on the International Space Station since 2012 for the purpose of SDR TRL advancement, among other things (13). Many radios can provide RF output power to the antenna directly. For higher power applications, an external RF amplifier or high gain antenna may be used. The reader is encouraged to refer to the SmallSat Avionics chapter for further information on FPGAs and SDRs. Please see table 9-4 for information on commercially available radios for SmallSat/CubeSats.

This report recommends efficient modulation and coding schemes for spacecraft power and bandwidth to increase the data rate and meet bandwidth constraints with the limited power and mass for CubeSat spacecraft. Advanced coding, such as the CCSDS low-density parity-check code (LDPC) family, with various code rates is a powerful technique to provide bandwidth and power tradeoffs with high-order modulation to achieve high data rate requirements for CubeSat missions. Digital Video Broadcast Satellite Second Generation (DVB-S2), a significant satellite communications standard, is a family of modulations and codes for maximizing data rates and minimizing bandwidth use, along with size, weight, and power (SWaP). DVB-S2 uses power and bandwidth efficient modulation and coding techniques to deliver performance approaching theoretical limits of RF channels. NASA's NSN has conducted testing at NASA Wallops Flight Facility (WFF) to successfully demonstrate DVB-S2 over a S-band 5 MHz channel achieving 15 Mbps with 16 APSK LDPC 9/10 code (14).



*Figure 9.6: Example of software defined radio, tunable in the range 70 MHz to 6 GHz. Credit: GomSpace.*

### 9.2.9 On the Horizon RF Communications

As CubeSat missions employ more automation, constellations could exchange information to maintain precise positions without input from the ground. Radiometric ranging is a function recently incorporated into CubeSat transceivers. A timing signal is embedded into the radio signal and is used to determine the range to the spacecraft. Using this method along with directional vectors obtained from ground antennas allows for trajectory determination of satellites beyond low-Earth orbit. Spacecraft may relay data to increase the coverage from limited ground stations. Inter-CubeSat transponders may very well become a vital element of eventual deep space missions, since CubeSats are typically limited in broadcasting power due to their small size, and may be better suited to relay information to Earth via a larger, more powerful mothership.

A CubeSat constellation may involve numerous CubeSats in the constellation (e.g., tens or hundreds). Each CubeSat is typically identical from a communication perspective. One CubeSat





may be mother ship-capable while the others may be subordinate (e.g., daughterships), however, multiple CubeSats may have the ability to fulfill the role of a mothership. CubeSat constellations optimize coverage over specific areas or improve global revisit times to fulfill mission objectives. There is growing interest among the NASA science community in using constellations of CubeSats to enhance observations for Earth and space science. NASA GSFC has conducted research on future CubeSat constellations, including CubeSat swarms, daughter ship/mother ship constellations, NEN S- and X-band direct-to-ground links, TDRS Multiple Access (MA) arrays, and Single Access modes. The MA array requires the use of spread-spectrum to support multiple simultaneous communications links to increase coverage and link availability.

Spacecraft routinely use transponders, however, networked swarms of CubeSats that pass information to each other and then eventually to ground, have not flown. Developing networked swarms is less of a hardware engineering problem than a systems and software engineering problem in that one must manage multiple dynamic communication links.

As of this 2022 edition, only the two MarCO SmallSats have operated beyond low-Earth orbit. Both satellites used a deployable reflectarray panel at X-band and were equipped with a full-duplex radio providing both UHF and X-band coverage. This allowed for near real-time updates of the InSight rover's landing. After this success, more SmallSats may be deployed beyond low-Earth orbit. The ability to provide crosslink relay hops for large spacecraft will prove to be critical for deep space missions.

IRIS Version 2 is a CubeSat/SmallSat compatible transponder developed by NASA Jet Propulsion Laboratory (JPL) as a low volume and mass, lower power and cost, software/firmware defined telecommunications subsystem for deep space technology demonstration missions (15). IRIS is designed to be radiation-hardened for deep space missions and interoperable with the NASA Deep Space Network (DSN). Launch date is currently TBD.

Several projects funded via NASA's Small Spacecraft Technology (SST) program through the Smallsat Technology Partnerships (STP) initiative have begun advancing RF Communication systems. Listed below in table 9-2 are projects that focused on RF technology advancement, and further information can be found at the STP website:

[https://www.nasa.gov/directorates/spacetech/small\\_spacecraft/smallsat-technology-partnership-initiative](https://www.nasa.gov/directorates/spacetech/small_spacecraft/smallsat-technology-partnership-initiative)

Each presentation is from the STP Technology Exposition that was held in June 2022.

<b>Project</b>	<b>University</b>	<b>Current Status</b>	<b>Reference</b>
FIGARO, 5G arrays for lunar relay operations	San Diego State	Still in development	<a href="#">STP Technology Expo presentation</a>
A Small Satellite Lunar Communications and Navigation System	University of Colorado, Boulder	Still in development	<a href="#">STP Technology Expo presentation</a>

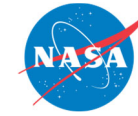
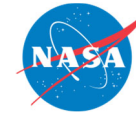


Table 9-3: Antennas

Manufacturer	Product	Type	Min Frequency	Frequency Band	Gain	Polarization	Mass	Dimensions	Flight Heritage
---	---	---	[MHz]	--	[dBi]	--	[g]	[cm]	---
Haigh-Farr, Inc.	Part Number: 17100	Crossed Dipole	307	VHF,UHF	--	RHCP	267	32x8x1	Y
GomSpace	NanoCom ANT430	Omni Canted Turnstile	400-435	VHF, UHF	1.5	Circular	30	10x10	Y
Helical Communications Technologies	Helios Deployable Antenna	Helical	400-3000	VHF, S	3	Circular	180	10x10x3.5	Y
NanoAvionics	CubeSat UHF Antenna System	Turnstile	400-500	VHF, UHF	1.37	--	33	10x10x0.7	
EnduroSat	UHF Antenna III	Whip/Burnwire	435-438	VHF, UHF	> 0	RHCP	85	10x10	Y
ISISPACE	CubeSat Antenna System for 1U/3U	Tape	--	VHF, UHF	0	Circular, Linear	89	10x10x0.7	Y
Flexitech Aerospace	600MHz - 10GHz Spiral Antenna	Spiral	600-10000	UHF, L, S, C, X	3	Circular	1283	17x17x8.5	N
NAL Research Corporation	Antenna SYN7391-A/B/C (Iridium)	Flat Mount	1610-1626.5	L	4.9	RHCP	31	4.6x4.3x1.0	Y
Flexitech Aerospace	2-2.5GHz Turnstile Antenna	Turnstile	2000-2500	S	5	Circular	173	--	N
Vulcan Wireless	ANT-S/S Unified S-Band Antenna	Patch	2025-2300	S	6.5	Circular	76	8x8x1	Y
EnduroSat	S-band Patch Antenna	Patch	2025-2110	S	7	Circular	64	10x10	Y
Syrlinks	SPAN-S-T3	Patch	2025-2290	S	4.8	Circular	117	8x8x11	Y
IQ Spacecom	S-band Patch Antenna	Patch	2100-2500	S	6	Circular	49	7x7x1	Y
ISISPACE	S-Band Patch Antenna	Patch	2200-2290	S	6.5	RHCP	50	8x8x1	N



Haigh-Farr, Inc.	S-band Patch Antenna	Patch	2245-2245	S	--	RHCP	48	4.8x6.5x6.5	Y
EnduroSat	X-band Patch Antenna	Patch	8025-8400	X	6	RHCP	2.2	--	Y
Syrlinks	SPAN-X-T2	Patch	8025-8450	X	7.6	RHCP	68	10x10x7	Y
Syrlinks	SPAN-X-T3	Patch	8025-8400	X	11.5	Circular	65	7.3x7.3x11	Y
Cesium Astro	Nightingale	Phased Array	27000-40000	Ka	30	Circular	1200	18x18x2	N
Oxford Space Systems	Helical antenna	Deployable	--	862 – 928 MHz	6.5	RHCP	~300	33	Y
Oxford Space Systems	Yagi antenna	Deployable	--	156.5 -162.5 MHz	6.5	Dual Linear	<1kg	100 x 70	Y
Oxford Space Systems	Deployable Cassegrain Wrapped Rib Antenna	Deployable	--	X-band	46 - 49	Linear	25kg to 38kg	300 - 500	N
Oxford Space Systems	Deployable Parabolic Offset Reflector	Deployable	--	C-band	42	Linear	from 12kg to 21kg	200 - 600	N
Oxford Space Systems	Deployable Hinged Rib Metal Mesh	Deployable	--	K/Ka-band	41	Linear	~2-3kg	~60	N
Redwire Space	Narwhal Antenna	Helical	100 – 4 GHz	L	6-18	Circular	0.003 2	1.25U x 1.25U x 2U	N
C3S Electronics Development LLC	CubeSat Antenna System	Dipole	400 Mhz	UHF	3.8	Linear	150-200	100 x 100 x 18 mm	Y

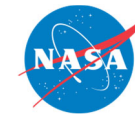
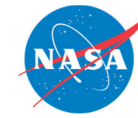
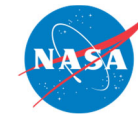


Table 9-4: Radios

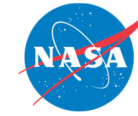
Manufacturer	Product	Type	Min Frequency	Frequency Band	Data Rate	Tx Power	Mass	Dimensions	Flight Heritage
---	---	---	[MHz]	--	[kbps]	--	[g]	[cm]	---
Space Micro	MicroSDR-C	SDR	70-3000	VHF, UHF, L, S, C	42,000	0	750	10x10x8	Y
GomSpace	NanoCom SDR	SDR	70-6000	VHF, UHF, L, S, X	--	--	271	9x9x6.6	Y
NI Ettus Research	B205mini	SDR	70-6000	VHF, UHF, L, S, X	--	10 dBm	24	8.3x5.1x8	Y
AstroDev	Helium-100	Transceiver	120-150 400-450	VHF, UHF	38.4	3 W	78	9.6x9x1.6	Y
AstroDev	Lithium-1	Transceiver	130-450	VHF, UHF	9.6	0.25-4 W	48	1.0x3.3x6.5	Y
AstroDev	Beryllium-2	Transceiver	130-450	VHF, UHF	9.6	0.25-4 W	52	1x3.3x6.5	Y
GomSpace	NanoCom AX100	Transceiver	143-150 430-440	VHF, UHF	0.1-38.4	30 dBm	24.5	6.5x4x7	Y
Spacemanic	Murgas_trx_VHF	Transceiver	144 MHz	VHF, UHF	9.6	+30dBm	25	6.7x4.2x0.7	Y
LY3H	SatCOM TP0	FM Repeater	144-146 430-440	VHF, UHF	--	217 mW	59	--	Y
ISISPACE	TRXVU	Transceiver	145.8-150.05 400.15-440	VHF, UHF	9.6	27 dBm	75	9x9.5x1.5	Y
AAC Clyde Space	TRX-U	Transceiver	390-450	UHF	19.2	2	140	8.3x5.7x1.6	Y
NanoAvionics	SatCOM UHF	Transceiver	395-440	VHF, UHF	2.4-38.4	3 W	7.5	5.6x3.3x6.6	Y
Spacemanic	Murgas_trx_UHFFlow	Transceiver	399 MHz	UHF	9.6	+30dBm	25	6.7x4.2x0.7	N
EnduroSat	UHF Transceiver Type II	Transceiver	400-403 430-440	UHF	19.2	2 W	94	10x10x2	Y
Spacemanic	Murgas_trx_UHF	Transceiver	420 MHz	UHF	9.6	+30dBm	25	6.7x4.2x0.7	Y
L3 Communications, Inc./SDL	Cadet	SDR	450	VHF, UHF	3,000	--	200	6.9x7.4x1.34	Y
AAC Clyde Space	PULSAR-VUTRX	SDR	--	VHF, UHF	9.6	1.5 W	100	9.6x9x1.6	Y



NearSpace Launch	EyeStar-D2	Transceiver	1610-1625 2484-2499	L	10,000	0.8 W	138	6.1x11.9x2.2	Y
sci_Zone, Inc.	LinkStar-STX3	Transmitter	1610-1625	L	0.009	--	48	8.6x5.3x2.9	Y
Qualcomm	GSP-1720	Transmitter	1610-1626.5 2483.5-2500	L, S	9.6	31 dBm	60	11.9x6.5x1.5	Y
NAL Research Corporation	NAL Iridium 9602-LP,	Iridium Satellite Tracker	1616-1626.5	L	--	1 W	136	6.9x5.5x2.4	Y
NearSpace Launch	EyeStar-S3	Transmitter	1616.25	L	600	20 dBm	22	1.5x2.6x5.5	Y
L3Harris	CXS-1000	Transponder	1700-2100	L,S	20,000	1-5 W	1360	10x10x11	Y
Tethers Unlimited	SWIFT-SLX	SDR	1700-2500	S	6,000	33 dBm	300	9x9.8x3.6	Y
Tethers Unlimited	SWIFT-XTS S Transceiver X Transmitter	SDR	1700-2500 7000-8500	S, X	6,000- 25,000	34 dBm	800	9x9.8x6	Y
AAC Clyde Space	TX-2400	Transmitter	2000 to 2300	S	6,000	2.5	70	6.8x3.5x1.5	Y
Syrlinks	EWC27 + OPT27- SRX S/X Transceiver	Transceiver	2025-2110	S	100,000	27-33 dBm	400	9x9.6x3.9	Y
Innoflight, Inc.	SCR-104	SDR	Tx: 2200-2300 Rx: 1760-1840 2025-2110	L, S	4500	1	290	9.8x8x3	Y
IQ Wireless GmbH	HISPICO	Transmitter	2100-2500	S	1,000	27 dBm	100	9.5x4.6x1.5	Y
Emhiser Research, Inc.	ETT-01EBA102-00	Transmitter	2200-2400	S	--	1 W	57	3x8.6x0.8	Y
Quasonix	NanoTX	Transmitter	2200.5-2394.5	S	50	1-10 W	Request	3.3x8.6x0.8	Y
IQ Wireless GmbH	SLINK-PHY	Transceiver	2200-2290 2025-2110	S	64-4,000	30 dBm	275	6.5x6.5x13.7	Y
ISISPACE	TXS	Transceiver	2200-2290	S	4.3	27-33 dBm	132	9.8x9.3x1.4	Y
Syrlinks	S-band Transponder EWC31	Transponder	2200-2290 2025-2110	S	8-2,000	27-33 dBm	--	--	Y



EnduroSat	S-band Transmitter	Transmitter	2200-2290 2400-2450	S	20,000	0.5-2 W	250	--	Y
General Dynamics	S-Band TDRSS/DSN	Transponder	Tx: 2200-2300 Rx: 2025-2220	S	12,000	0.03 W	4900	19x23x15	Y
Microhard	Nano N2420	Modem	2400-2483.5	S	230	0.1-1 W	210	5x3x0.6	Y
Honeywell	STC-MS03	Transceiver	--	S	6,250	3.16 W	1000	16x11x4.4	Y
AAC Clyde Space	PULSAR-DATA STX S-Band Transmitter	SDR	--	S	7,500	1 W	100	9.6x9x1.7	Y
Laboratory for Atmospheric and Space Physics (LASP)/Blue Canyon Technologies (BCT)	X-band Radio	SDR	Tx: 2200-2500 8000-8500 21000-33000 Rx: 1760-1840 2000-2110 21000-23000	Downlink: S, X, Ka Uplink: L, S, Ka	100,000	30 dBm	--	4.5x4.35x1.2 5	Y
Tethers Unlimited	SWIFT-XTX X Transmitter	SDR	7000-8500	X	25,000	33 dBm	300	9x9.8x6	N
General Dynamics	X-Band Small Deep Space	Transponder	7145 -7230 8400-8500	X	100,000	0.06	3200	18x17x11	Y
JPL/SDL	IRIS V2	Transponder	7200-8400	X, Ka	--	3.8 W	1200	10x10x5.6	Y
Innoflight, Inc.	SCR-106	SDR	Tx: 7900-8500 Rx: 1760-1840 2025-2110	X	150,000	0.02-2.5 W	290	9.8x8.2x2.8	N
EnduroSat	X-band Transmitter	Transmitter	7900 to 8400	X	150,000	27-33 dBm	270	9x9.6x2.6	Y
IQ Wireless GmbH	XLINK	Transceiver	8025-8500 7145-7250	X	64-25,000	30 dBm	--	<1 U	Y
Syrlinks	X-band Transmitter EWC27	Transmitter	8025-8400	X	140,000	27-33 dBm	225	9x9.6x2.6	Y
AAC Clyde Space	PULSAR-DATA XTX X-Band Transmitter	SDR	--	X	50,000	2 W	130	9.6x9x1.1	Y
Tethers Unlimited	SWIFT-KTX Ka Transmitter	SDR	20200-21200 24000-27000	Ka	25,000	33 dBm	300	9x9.8x4	N
Tethers Unlimited	SWIFT-KTRX Ka Transmitter	SDR	24000-27000	Ka	1,000,000	35 dBm	1,000	16x9.6x6	N



SpaceMicro	microKaTx-300	Transmitter	25250-27250	K	1,000,000	2	1000	10x10x8	Y
CeisumAstro	SDR-1001	SDR	300 – 6000 (adjustable)	UHF, L, S, C	up to 62,500	-	100	5x8.4x1.3	N
C3S Electronics Development LLC	Communication Subsystem	Transceiver	400 MHz	UHF	1250 bps to 150 kbps	up to 30 dBm	114	92 x 80.9 x 12.8	Y

### 9.3 Free Space Optical Communications

Free space optical communications, or lasercom, uses optical wavelengths of electromagnetic radiation to transmit messages wirelessly between user terminals. While few small satellite optical communications terminals have flown, availability is rapidly changing, and optical communication is becoming a more common wireless communication technology for small satellites.

Due to the higher frequencies used in lasercom, the amount of bandwidth available for communicating is much larger compared to RF. This increase in bandwidth over RF enables much higher data rates. The beam width of a lasercom link is also typically much narrower than a RF link (figure 9.7). The amount that a transmitted beam spreads as a function of its propagation distance is called its divergence. The divergence of a beam is proportional to the wavelength of the electromagnetic wave transmitted divided by the transmitted beam diameter. The high frequencies used in lasercom mean the wavelength of the transmitted energy is orders of magnitude smaller than RF systems. These small wavelengths mean the transmitter diameters and beam divergence of lasercom systems can also be much smaller, which enables the size, weight, and power (SWaP) of lasercom systems to be lower than similar performing RF systems. Laser communications have a low probability of intercept, are difficult to jam, and encounter very little interference because of the narrow beamwidth. At present, optical frequencies are unregulated, unlike RF systems which require a licensing process to be able to communicate with a spacecraft. Lasercom is not without its disadvantages, which include the required pointing of the beam and the impact weather has on the signal. The small beam divergence of lasercom systems means that the acceptable pointing error is much smaller. The frequencies used in lasercom systems are also susceptible to large amounts of attenuation due to moisture in clouds. This attenuation prohibits communication while there is cloud cover and incentivizes operators to build their optical ground stations in areas that have infrequent cloud cover.

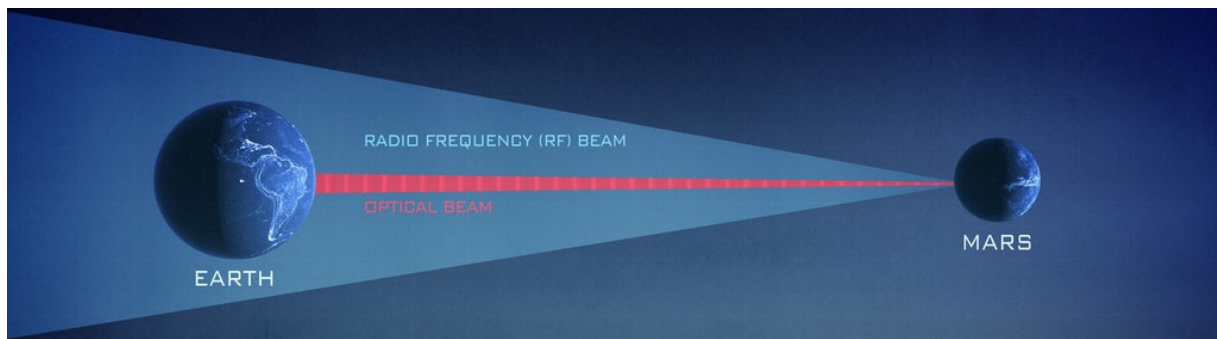


Figure 9.7: Laser vs RF link and data downlink. Credit: NASA.

While larger mission such as Geosynchronous Lightweight Technology Experiment (GeoLITE), Near Field Infrared Experiment (NFIRE), and Lunar Laser Communication Demonstration (LLCD) have demonstrated laser communications downlinks and crosslinks for over a decade, small satellites and CubeSats have also now successfully demonstrated laser communication downlinks from space. For example, the Aerospace Corporation, in cooperation with NASA ARC, launched three CubeSats in its AeroCube Optical Communication and Sensor Demonstration (OCSD) series (figure 9.8). OCSD-B & C demonstrated a 200 Mbps

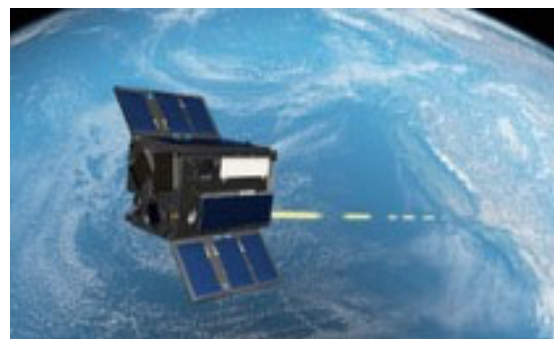


Figure 9.8: An artist rendering of laser communications for the OCSD. Credit: NASA.



downlink from a 1.5U CubeSat satellite to a 40 cm ground station (16). The Aerospace Corporation transmitter has also successfully flown on follow-on missions that were able to use lasercom systems to downlink science data (17).

### 9.3.1 System Architecture

An optical modem, optical amplifier, and optical head typically comprise a lasercom terminal (LCT) (see figure 9.9 for an example laser terminal system diagram). As with radio terminals, component locations in optical terminals can vary; for example, the modulator may not be located proximal to the optical front end. Also, the pointing mechanism might differ from the one shown in figure 9.9.

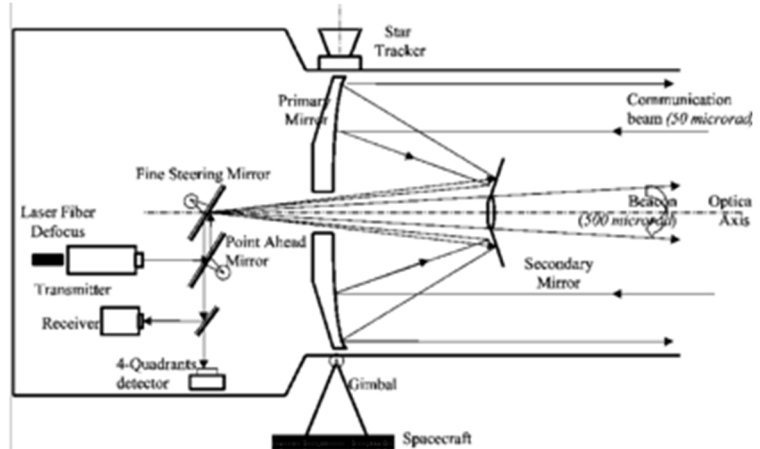


Figure 9.9: Laser terminal architecture diagram. Credit: M. Guelman et al. (2004).

The key parameters of an optical communication system are frequency, modulation, aperture size, and range. Successful optical communications links typically require high pointing accuracy. The optical communication terminal on a spacecraft typically has a two-stage pointing system, with a coarse-pointing stage and a fine-pointing stage. The optical communication system often relies heavily on the spacecraft attitude determination and control system (ADCS) for coarse-pointing, and may use a second pointing mechanism such as a gimbal as additional support for coarse pointing. Fine pointing is often implemented with additional mirrors in the payload. However, pointing that is solely dependent on spacecraft attitude control has also been demonstrated. On transmit, energy passing through the optical aperture forms a very narrow beam. The larger the aperture, the narrower the beam; this creates higher power density at a receiver for a given range. In order for two communication terminals to locate each other, they may shine higher power and broader-beam “beacon” lasers to find each other before engaging the narrower and higher data rate link. The beacon itself may also be modulated. Optical modems may be software defined and can support multiple modulation and coding schemes, similar to RF.

### 9.3.2 Optical Ground Stations

The ground stations for optical communications understandably differ significantly from RF ground stations due to the need to have the receiving aperture (typically a mirrored telescope) maintain an optical-quality surface to focus the collected optical energy onto a receiver. Optical ground stations are often located at or near astronomical telescope sites located in favorable environments. Optical ground stations are typically mounted inside protected domes or other structures to cover them during bad weather. These structures need to be opened for clear access to the sky. Since optical ground stations often have beacons, it is important to consider laser safety and proximity to airports. Typical ground-to-space beacons are tens of watts of optical power for low-Earth orbit missions. Most optical ground stations are experimental facilities used for campaigns with specific research missions, although there has been recent development in commercial optical ground stations. For a more detailed outline of existing optical ground stations, refer to Chapter 11.



### 9.3.3 Design Considerations

Lasercom terminals can offer a smaller footprint and power draw compared to an RF terminal. However, lasercom pointing requirements are significantly tighter. One of the largest challenges to mainstream implementation is the required pointing for the LCT. To manage this, each system architecture will describe the specific system of pointing used. The LCTs that have been designed, built, and operated on small satellite and CubeSat platforms have some significant differences from LCTs designed for larger spacecraft. Given the size, weight, and power constraints, SmallSat LCTs usually do not use mechanical gimbals. SmallSat lasercom systems solely or largely rely on the body pointing of the satellite to point the LCT at the ground station and may use an internal fine pointing mechanism to achieve the required pointing performance.

On SmallSat platforms, the limited volume and tight packaging is often a major challenge in the design of low-SWaP LCTs. There are thermal management challenges during operation, as it is difficult to radiate enough heat with limited surface area for radiators. There are also power constraints, due to limited surface area for solar arrays and secondary battery systems. In addition, not all SmallSat platforms can achieve the pointing requirements necessary for laser communications. Typically, precise three-axis reaction wheels and attitude determination from one or more star trackers is necessary.

While RF bands with high frequency and bandwidth are affected by clouds and rain, cloud cover can prove difficult or even insurmountable for optical communications due to the high levels of attenuation by water vapor. If the cloud coverage is too great at a specific ground station, the transmission may be held for a later time or passed off to a different ground station. With advances in intersatellite networking and the development of extensive networks of optical communication ground stations, routing data around weather may become more feasible.

The atmosphere is also a source of aberrations for optical communication systems. For example, some high-rate optical downlink terminals that require coupling the received light into fiber receivers must use adaptive optics to correct atmospheric effects on the incident wavefront. The correction of the wavefront is required because of the lack of power that would couple into the receive optical fiber due to the perturbed wavefront of the received light. Adaptive optics systems take a sample of the incident wavefront and measure the aberration to feed into the control of the adaptive optics system acting on the received light.

Lasercom crosslinks can provide a high bandwidth connection between two satellites, as well as perform ranging between the satellites, potentially with high ranging precision. Connecting two satellites across different orbit planes helps with data routing and can reduce how long it takes to route data to the end use. Lasercom crosslink systems are now in use for both commercial and government missions. Lasercom crosslink demonstrations have been performed from GEO-LEO, LEO-GEO, and LEO-LEO, and are operational as part of the European Data Relay Service (37 38), but these LCTs were developed for much larger spacecraft (19, 20). Crosslinks also have the challenge of both terminals being resource-constrained onboard a spacecraft. Space-to-ground links have an advantage in that the ground station apertures can be large with essentially unconstrained resources. The challenges facing inter-satellite optical communications also centers on pointing, acquisition, and tracking (PAT) requirements. Satellites in different orbital planes can have high relative velocities and performing pointing, acquisition, and tracking of the terminal can be a challenge. An advanced opto-mechanical system may be needed to surmount this challenge, and modifications to the receive optics may be required to manage high Doppler shift.



### 9.3.4 Policies and Licensing

Given the early stages of development for optical communication systems, both policy and regulatory approaches are still evolving. In the policy realm, there is an initial draft CCSDS Pink Book in process (CCSDS 141.0-P-1.1) with a goal to facilitate interoperability and cross-support between different communication systems. There is also an optical communication working group with NASA and ESA participation.

Regarding licensing and regulation, the situation is very different from the radio frequency domain. Currently there are no licensing requirements for laser communications. In the radio frequency spectrum, the main goal for licensing is to prevent interference between transmitters.

Lasercom interference is not currently coordinated by a regulatory body (like the ITU or NTIA in RF) for two major reasons:

- 1) Laser communications is highly directional, which makes interference unlikely, due to the narrow divergence of the transmitting beam and corresponding small beam footprint at the receiver.
- 2) The small number of laser communications systems currently deployed doesn't warrant a complex coordination body like the ITU.

However, in the US there are three regulatory entities that are concerned with aspects of outdoor laser operations: The FAA, DoD Laser Clearing House (for DoD missions) and the NASA Laser Safety Review Board (for NASA missions).

FAA coordination is required if potentially harmful laser irradiance is transmitted through navigable airspace. This includes prevention of injury as well as potential distraction of pilots by visible lasers. The FAA will most likely only be concerned about transmitters at ground stations because transmitters on spacecraft are hundreds of miles above the highest-flying aircraft and beam dispersion is large enough that there are usually no safety implications. Missions should coordinate with their local FAA service center to get approval, documented with a "letter of non-objection."

The DoD Laser Clearinghouse (LCH) works to ensure that DoD and DoD-sponsored outdoor laser use does not impact orbiting spacecraft or their sensors. That includes both US DoD and foreign assets. LCH and mission operators might enter close cooperation where LCH permits specific laser engagements. The process of coordinating with LCH to get to that point can take many months and should be started as early as possible. However, currently LCH will only engage DoD and DOD-sponsored missions.

NASA's Laser Safety Review Board (LSRB) is focused on personnel safety for all outdoor laser operations. NASA missions prepare safety documentation and submit to LSRB for review before launch. LSRB will also verify FAA concurrence. Further information on regulations can be found in ANSI Z136.6 "American National Standard for Safe Use of Lasers Outdoors" and in (39).

### 9.3.5 Mission Examples

Missions demonstrating lasercom terminals on small satellite and CubeSat platforms have shown viable pathways for overcoming the challenges associated with lasercom in order to enable high bandwidth communications. Please refer to table 9-5 for more information on lasercomm missions.

The Small Optical Transponder (SOTA) was developed by the National Institute of Information and Communications Technology (NICT) in Japan and launched in 2014. This LCT is capable of up to 10 Mbps and has successfully demonstrated a laser space-ground link from a 50 kg microsatellite (21). The Very Small Optical Transponder (VSOTA) LCT, also developed by NICT,



is capable of 1 Mbps. VSOTA was integrated into the Rapid International Scientific Experiment Satellite (RISESAT) from Tohoku University and launched in 2019 (22).

The German Aerospace Center (DLR) has been developing LCTs as part of its Optical Space Infrared Downlink System (OSIRIS) program to support lasercom from small satellites. The first, OSIRISv1 is capable of 200 Mbps downlinks and is integrated into the University of Stuttgart's Flying Laptop satellite. This LCT uses a body pointing-only approach. The OSIRISv1 LCT, launched in 2017, has completed commissioning and is being used by DLR to test their optical ground stations. The OSIRISv2 LCT, launched in 2016, is capable of 1 Gbps and is integrated into the BiROS satellite from DLR Berlin. This LCT uses closed-loop body pointing with a beacon reference. The OSIRISv2 LCT has been undergoing commissioning with parts of the terminal having been commissioned (23-25).

The Aerospace Corporation completed the first demonstration of optical communication from a CubeSat platform with the NASA-sponsored Optical Communication and Sensor Demonstration (OCSD) mission. These terminals were integrated into a 1.5U CubeSat and rely only on body pointing. The use of body pointing-only comes from using high optical power amplifiers with a larger beam divergence tuned to the pointing performance capability of their spacecraft. The terminals achieved a 200 Mbps downlink data rate to a 40 cm ground station and do not use a beacon for a pointing reference (16). This transmitter has been flown since on multiple missions such as R3 (17) and the Rogue Alpha and Beta CubeSats (18).

As part of NASA's CLICK mission, MIT developed the 1.2U CLICK-A terminal. The first phase of the mission is flying the CLICK-A downlink terminal on a 3U CubeSat to demonstrate an optical design that uses a secondary fine pointing micro-electromechanical systems (MEMS) fine-steering mirror (FSM) to achieve the necessary pointing requirements for optical communication without imposing those requirements on the spacecraft pointing or needing large gimbals. This LCT uses closed-loop fine pointing with a beacon reference and is designed to close its link with a 28 cm ground station. The terminal is integrated into a Blue Canyon Technology's XB1 spacecraft bus and was launched to and deployed from the ISS in 2022. CLICK-A ultimately serves as a risk-reduction phase for the CLICK-B/C phases of the mission described later in this section (26).

DLR has also been developing their OSIRIS4 CubeSat transmitter. This optical communication terminal is designed to demonstrate an optical downlink in a 0.3U package. This transmitter also uses a MEMS FSM fine pointing mirror and was launched on the PIXL-1 mission in 2021. A beacon is used for fine pointing reference with this terminal. This terminal is designed to be used with a 60 cm optical receiver and has been commercialized through TESAT with the product name CubeLCT (27).

Sony Computer Science Lab and the Japanese Aerospace Exploration Agency (JAXA) jointly developed a LCT called Small Optical Link for ISS (SOLISS). This LCT is capable of bidirectional 100 Mbps links and was launched to and mounted on the ISS in 2019. This LCT has been successfully demonstrated with NICT's ground station (28, 29).

MIT Lincoln Laboratory developed the TBIRD terminal, which supports 200 Gbps downlinks. The transmitter uses commercial fiber telecommunication components to support very high data rates. This project is planned to downlink to NASA JPL's Optical Communication Telescope Laboratory (OCTL), which hosts a 1 m telescope with the adaptive optics necessary to couple the received light back into a fiber transceiver card. This terminal development was sponsored by NASA and was launched on the PDT-3 6U CubeSat mission in June of 2022 (30).

Future mission launches include the CLICK-B/C terminals. The CLICK-B/C phase of the CLICK mission is developing a 1.5U crosslink LCT. The CLICK-B/C crosslink LCT is designed to



establish a 20 Mbps link at separations from 25 to 580 km. CLICK-B & C will each be integrated into its own 3U Blue Canyon Technologies XB1 spacecraft. The LCTs are designed to be capable of precision ranging up to a precision of 50 cm relative to each other. The spacecraft will be launched to and deployed from the ISS in 2023 and fly in the same orbital plane (26).

While results have not been shown on a flown mission, the CubeCat LCT is a commercial product by AAC Clyde Space that offers a bidirectional space-to-ground communication link between a CubeSat and an optical ground station. This LCT offers downlink speeds of up to 1 Gbps and an uplink data rate of 200 Kbps (31).

### **9.3.6 Future Technologies**

While free space optical communication technology development has been making strides towards fielding operational systems, other avenues of research have also been explored. Quantum key distribution is a protocol that shares a secret cryptographic key through entangled photons. Sources and optical front ends have been developed for transmitting these keys from small satellite spaceborne platforms (32, 33). The Deployable Optical Receiver Aperture (DORA) project, which is developing a 1 Gbps crosslink LCT (34), is a novel approach to deploying large apertures in space. The inter-spacecraft optical communicator (ISOC), which includes arrays of fast photodetectors and transmit telescopes to provide full-sky coverage, gigabit data rates and multiple simultaneous links, was initially developed at NASA's Jet Propulsion Laboratory with funding from NASA's Small Spacecraft Technology (SST) program from 2018 to 2020. An advanced version of the ISOC is currently being developed by Chascii Inc. with funding from NASA Small Business Innovation Research Program for cislunar applications. There are currently several ISOC versions for short-, mid-, and long-range applications that use appropriate levels of power and aperture size, respectively, to achieve gigabit connectivity (35). Another approach to expanding the communication windows for small satellites in low-Earth orbit is to form an intersatellite link to geosynchronous orbit. Major programs, such as the previously mentioned European Data Relay System use this type of link. NICT is looking to establish this type of link with a CubeSat through the CubeSOTA program (36). In addition to CubeSat terminals, larger terminals for larger SmallSats are under development by Tesat, Mynaric (26), SpaceMicro (27), and SA Photonics. DARPA has funded the Space-BACN program that seeks to develop a reconfigurable and multi-protocol inter-satellite LCT that can be supported on small satellites.

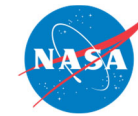


Table 9-5: LCT Technologies									
Vendor/Developer	Terminal	Platform	Data Rate	Mass	Power	Wavelength	Modulation	Launch Date	Reference
---	---	---	[Mbps]	[kg]	[W]	[nm]	---	---	---
NICT	SOTA	SOCRATES	10	5.9	16	976/800/1549	OOK	5.2014	21
DLR	OSIRISv2	BiROS	1000	1.65	37	1550	OOK	6.2016	24
DLR	OSIRISv1	Flying Laptop	200	1.3	26	1550	OOK	7.2017	23, 24, 25
Aerospace Corporation	OCSD-B&C	AeroCube-7	200	<2.3	20	1064	OOK	12.2017	16
NICT	VSOTA	RISESAT	1	<1	4.33	980/1550	OOK/PPM	1.2019	22
Sony/JAXA	SOLISS	ISS	100	9.8	36	1550	OOK	7.2019	28, 29
DLR	OSIRIS4CubeSat	PIXL-1	100	0.4	10	1550	OOK	1.2021	27
MIT Lincoln Labs	TBIRD	PDT-3	200,000	<3	100	1550	QPSK	5.2022	30
MIT	CLICK-A	CLICK	10	1.2	15	1550	PPM	7.2022	26
MIT	CLICK-B/C	CLICK	20	1.5	30	1537/1563	PPM	Est. 2023	26
AAC Clyde Space	CubeCat	---	1000	<1.33	15	1550	OOK	---	31



## 9.4 Summary

There is already strong flight heritage for many UHF/VHF and S-band communication systems for CubeSats. Less common, but with growing flight heritage, are X-band systems. Higher RF frequencies and laser communication already have CubeSat flight heritage, but with limited (or yet to be demonstrated) performance. Although there are limited Ka-band systems for CubeSats today, high-rate transmitters such as the Astro Digital AS-10075 demonstrated 320 Mbps in the Landmapper-BC 3 v2 mission. On the other hand, laser communication has been demonstrated on a CubeSat platform, but is still an uncommon technology. Improved demonstrations are in development, with some already launched and operating, to show higher data rates and increased pointing performance. Since optical communications uplink and downlink can be blocked by clouds, RF is considered complementary to maintain contact under all conditions. There is growing interest among the NASA science community in using constellations of CubeSats to enhance observations for Earth and space science.

For feedback solicitation, please email: [arc-sst-soa@mail.nasa.gov](mailto:arc-sst-soa@mail.nasa.gov). Please include a business email for further contact.

## References

- (1) J.N Pelton. "The Basics of Satellite Communications." s.l.: Professional Education International, Inc., 2006.
- (2) NASA "Integrated Solar Array and Reflectarray Antenna (ISARA) for High Bandwidth CubeSats." [Online] July 26, 2016. Available at: [https://www.nasa.gov/sites/default/files/atoms/files/isara\\_fact\\_sheet-26july2016.pdf](https://www.nasa.gov/sites/default/files/atoms/files/isara_fact_sheet-26july2016.pdf)
- (3) JPL. Mars Cube One (MarCO). Jet Propulsion Laboratory California Institute of Technology | CubeSat. [Online] Available at: <https://www.jpl.nasa.gov/cubesat/missions/marco.php>
- (4) S. Xie et al. "Wireless Sensor Network for Satellite Applications: A Survey and Case Study." Unmanned Systems, Vol. 2, pp. 261-277, 2014.
- (5) R. Schoemaker and J. Bouwmeester. "Evaluation of Bluetooth Low Energy Wireless Internal Data Communication for Nanosatellites." Small Satellites Systems and Services Symposium. pp. 1-15, 2014.
- (6) P.G. Farrell and A.P. Clark. "Modulation and coding." International Journal of Satellite Communications, 1984.
- (7) A. Datta. "New FCC rules make small satellite licensing easier, faster, and cheaper. Geospatial World | Advancing Knowledge for Sustainability." [Online] August 22, 2020. Available at: <https://www.geospatialworld.net/blogs/new-fcc-rules-make-small-satellite-licensing-easier-faster-and-cheaper/>
- (8) J. Buxton and D. Glasbrenner. "AMATEUR RADIO AND EXPERIMENTAL LICENSING FOR CUBESATS."
- (9) CalPoly. "CubeSat Licensing Support." [Online] Available at: <https://www.cubesat.org/cubesatlicensingupport>
- (10) National Institute of Standards and Technology. "Security Requirements for Cryptographic Modules, Federal Information Processing Standard (FIPS). ISO/IEC 19790:2012; ISO/IEC 24759:2014
- (11) 47 CFR Part 97 - AMATEUR RADIO SERVICE. [Online] Available at: <https://www.law.cornell.edu/cfr/text/47/part-97>
- (12) J.R. Wertz, D.F. Everett, and J.J. Puschell. "Space Mission Engineering: The New SMAD." Microcosm Press, Hawthorne, CA, 2015.
- (13) S.K. Johnson, R.C. Reinhart, and T.J. Kacpura. "CoNNeCT's approach for the development of three Software Defined Radios for space application." IEEE Aerospace Conference. pp. 1-13, Big Sky, MT, 2012.



- (14) Y. Wong et al. "NASA Near Earth Network (NEN) DVB-S2 Demonstration Testing for Enhancing Data Rates for CubeSats." 31<sup>st</sup> Annual AIAA/USU Conference on Small Satellites, Logan, UT, 2019.
- (15) JPL. "Iris V2 CubeSat Deep-Space Transponder (IRIS)." [Online] Available at: <https://www.jpl.nasa.gov/cubesat/missions/iris.php>
- (16) [101] T.S. Rose, D.W. Rowen, S.D. LaLumondiere, N.I. Werner, R. Linares, A.C. Faler, J.M. Wicker, C.M. Coffman, G.A. Maul, D.H. Chien, A.C. Utter, R.P. Welle, and S.W. Janson. "Optical communications downlink from a low-earth orbiting 1.5U CubeSat," *Opt. Express* 27, 24382-24392, 2019.
- (17) D.W. Pack, G. Kinum, P.D. Johnson, T.S. Wilkinson, C.M Coffman, J.C. Mauerhan, B.S. Hardy, R. Russell, and K. Mercy. "Landsat Imagery from a CubeSat: Results and Operational Lessons from the R3 Satellite's First 18 Months in Space." Small Satellite Conference, Logan UT, 2020.
- (18) D.W Pack, B.S Hardy, J.R. Santiago, D. Pietrowski, J.C. Mauerhan, P.F. Zittel, D.W. Rowen, C.R. Purcell, P. Thiyannaratnam, L.J. Gelinas, P.K. Su, J. Gussy, and J.M. Santiago. "Flight Operations of Two Rapidly Assembled CubeSats with Commercial Infrared Cameras: The Rogue-Alpha,Beta Program." Small Satellite Conference, Logan UT, 2021.
- (19) T. Jono, Y. Takayama, N. Kura, K. Ohinata, Y. Koyama, K. Shiratama, Z. Sodnik, B. Demellenne, A. Bird, and K. Arai. "OICETS on-orbit laser communication experiments. Page 610503, San Jose, CA, February 2006.
- (20) R. Fields, D. Kozlowski, H. Yura, R Wong, J Wicker, C. Lunde, M. Gregory, B Wandernoth, and F. Heine. "5.625 Gbps bidirectional laser communications measurements between the NFIRE satellite and an Optical Ground Station." International Conference on Space Optical Systems and Applications (ICSOS), pages 44–53, Santa Monica, CA, USA, May 2011. IEEE.
- (21) H. Takenaka, Y. Koyama, M Akioka, D. Kolev, N. Iwakiri, H. Kunimori, A. Carrasco-Casado, Y. Munemasa, E. Okamoto, M. Toyoshima. "In-orbit verification of small optical transponder (SOTA): evaluation of satellite-to-ground laser communication links." *Proc. SPIE 9739, Free-Space Laser Communication and Atmospheric Propagation XXVIII*, 973903, March 15, 2016.
- (22) H. Tomio, T. Kuwahara, S. Fujita, Y. Sato, M. Sakal, H. Kunimori, T. Kubooka, H. Takenaka, Y. Saito, M. Toyoshima. "Assembly and integration of optical downlink terminal VSOTA on microsatellite RISESAT." *Proc. SPIE 11180, International Conference on Space Optics — ICSO 2018*, 111805Z, July 12, 2019.
- (23) C. Schmidt, C. Fuchs, ""The OSIRIS program at DLR,"" *Proc. SPIE 10524, Free-Space Laser Communication and Atmospheric Propagation XXX*, 105240R, 5 February 15, 2018.
- (24) C. Fuchs, C. Schmidt, J. Keim, F. Moll, B. Rödiger, M. Lengowski, S. Gaißer, and D. Giggenbach. "Update on DLR's OSIRIS program and first results of OSIRISv1 on Flying Laptop." *Proc. SPIE 10910, Free-Space Laser Communications XXXI*, 109100S, March 4, 2019.
- (25) D. Giggenbach, C. Fuchs, C. Schmidt, B. Rödiger, S. Gaißer, S. Klinkner, D. Phung, J. Chabé, C. Courde, N. Maurice, H. Mariey, E. Samain, and G. Artaud. "Downlink communication experiments with OSIRISv1 laser terminal onboard Flying Laptop satellite." *Appl. Opt.* 61, 1938-1946, 2022.
- (26) W. Kammerer, P. Grenfell, L. Hiest, P. Serra, H. Tomio, N. Belsten, C. Lindsay, O. Čierny, K. Cahoy, M. Clark, D. Coogan, J. Conklin, D. Mayer, J. Stupl, J. Hanson. "CLICK Mission Flight Terminal Optomechanical Integration and Testing." International Conference on Space Optics — ICSO, 2022.



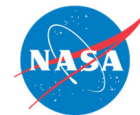


- (27) Tesat. "SMALLEST LASER COMMUNICATION TRANSMITTER WORLDWIDE." Technical Datasheet. [Online] 2022. Available at: [https://www.tesat.de/images/tesat/products/220607\\_DataSheet\\_CubeLCT100M\\_A4.pdf](https://www.tesat.de/images/tesat/products/220607_DataSheet_CubeLCT100M_A4.pdf)
- (28) K. Iwamoto, H. Komatsu, S. Ohta, Y. Kubo, T. Nakao, H. Yamazoe, T. Kamata, Y. Munemasa, H. Kunimori, M. Toyoshima, D. Koda, H. Sawada, T. Ikeda. "Experimental results on in-orbit technology demonstration of SOLISS." Proc. SPIE 11678, Free-Space Laser Communications XXXIII, 116780D, March 5, 2021.
- (29) H. Komatsu, S. Ohta, H. Yamazoe, Y. Kubo, T. Nakao, T. Ito, D. Koda, H. Sawada, T. Ikeda, Y. Munemasa, H. Kunimori, T. Kubooka, M. Toyoshima, K. Iwamoto. "The pointing performance of the optical communication terminal, SOLISS in the experimentation of bidirectional laser communication with an optical ground station." Proc. SPIE 11678, Free-Space Laser Communications XXXIII, 116780F, March 5, 2021.
- (30) Curt M. Schieler, Kathleen M. Riesing, Andrew J. Horvath, Bryan C. Bilyeu, Jesse S. Chang, Ajay S. Garg, Jade P. Wang, Bryan S. Robinson, "'200 Gbps TBIRD CubeSat downlink: pre-flight test results,'" Proc. SPIE 11993, Free-Space Laser Communications XXXIV, 119930P, March 4, 2022.
- (31) AAC Clyde Space. "LASER COMMUNICATIONS CUBECAT." Technical Datasheet. [Online] 2022. Available at: <https://www.aac-clyde.space/wp-content/uploads/2021/10/CUBECAT.pdf>
- (32) R. Bedington, J.M. Arrazola, and A. Ling. "Progress in satellite quantum key distribution." Npj Quantum Information Vol. 3, 30, 2017.
- (33) P. Serra, O. Čierny, W. Kammerer, E.S. Douglas, D.W. Kim, J.N. Ashcraft, G. Smith, C. Guthery, T. Vergoossen, A. Lohrmann, R. Bedington, C. Perumangatt, A. Ling, K. Cahoy. "Optical front-end for a quantum key distribution cubesat." Proc. SPIE 11852, International Conference on Space Optics, 118523C, June 11, 2021.
- (34) D. Jacobs, J. Bowman, M. Patterson, M. Horn, C. McCormick and M. Adkins. "Plan for On-Orbit Demonstration of the Deployable Optical Receiver Array." IEEE Aerospace Conference (AERO), pp. 1-8, 2022.
- (35) J.E. Velazco and J.S. de la Vega. "Q4 – A CubeSat Mission to Demonstrate Omnidirectional Optical Communications." IEEE Aerospace Conference, pp. 1-6, 2020.
- (36) A. Carrasco-Casado et al., "'Intersatellite-Link Demonstration Mission between CubeSOTA (LEO CubeSat) and ETS9-HICALI (GEO Satellite)." IEEE International Conference on Space Optical Systems and Applications (ICSOS), pp. 1-5, 2019.
- (37) European Space Agency. "European Data Relay Service." [Online] Available at: [https://www.esa.int/Applications/Telecommunications\\_Integrated\\_Applications/EDRS](https://www.esa.int/Applications/Telecommunications_Integrated_Applications/EDRS)
- (38) F. Heine, P. Martin-Pimentel, N. Höpcke, D. Hasler, C. Rochow, and H. Zech. "Status of tesat lasercomms activities." Free-Space Laser Communications XXXIII, vol. 11678, pp. 45-50. SPIE, 2021.
- (39) R. Lafon, J. Wu, B. Edwards. "Regulatory Considerations: Laser Safety and the Emerging Technology of Laser Communication." Commercial Laser Communications Interoperability and Regulatory Workshop, Washington, DC, June 12, 2017.



## Chapter Contents

Chapter Glossary .....	ii
10.0 Integration, Launch, and Deployment.....	252
10.1 Introduction .....	252
10.2 State-of-the-Art – Launch Integration Role.....	253
10.2.1 Launch Brokers and Services Providers.....	254
10.3 Launch Paradigms .....	254
10.3.1 Dedicated Launches .....	254
10.3.2 Traditional Rideshare Launches .....	255
10.4 Deployment Methods .....	255
10.4.1 CubeSat Dispensers.....	255
10.4.2 SmallSat Separation Systems .....	257
10.4.3 Integration Hardware .....	258
10.4.4 Orbital Maneuvering / Transfer Vehicles.....	259
10.5 International Space Station Options.....	261
10.5.1 Deployment from ISS .....	261
10.5.2 Deployment Above ISS.....	262
10.6 On the Horizon .....	263
10.6.1 Integration.....	263
10.6.2 Launch.....	263
10.6.3 Deployment .....	263
10.7 Summary.....	263
References.....	263



## Chapter Glossary

(CBOD)	Clamp Band Opening Device
(CDS)	CubeSat Design Specification
(CSLI)	CubeSat Launch Initiative
(DPAF)	Dual Payload Attach Fittings
(EAGLE)	ESPA Augmented Geostationary Laboratory Experiment
(EELV)	Evolved Expendable Launch Vehicle
(ENRCSD)	Nanoracks External CubeSat Deployer
(ESA)	European Space Agency
(ESPA)	EELV Secondary Payload Adapter
(GEO)	Geostationary Equatorial Orbit
(HEO)	Highly Elliptical Orbit
(ISS)	International Space Station
(J-SSOD)	JEM Small Satellite Orbital Deployer
(JAXA)	Japan Aerospace Exploration Agency
(JEM)	Japanese Experimental Module
(JEMRMS)	Japanese Experimental Module Remote Manipulator System
(M-OMV)	Minotaur Orbital Maneuvering Vehicle
(MEO)	Medium Earth Orbit
(MLB)	Motorized Light Bands
(MPAF)	Multi Payload Attach Fittings
(MPEP)	Multi-Purpose Experiment Platform
(NOAA)	National Oceanic and Atmospheric Administration
(NRCSD)	Nanoracks ISS CubeSat Deployer
(OMV)	Orbital Maneuvering Vehicle
(PCBM)	Cygnus Passive Common Berthing Mechanism
(SL-OMV)	Small Launch Orbital Maneuvering Vehicle
(SSMS)	Small Spacecraft Mission Service
(SSOD)	Small Satellite Orbital Deployer
(TRL)	Technology Readiness Level



## 10.0 Integration, Launch, and Deployment

### 10.1 Introduction

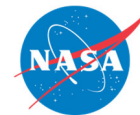
Of the more than 1,849 total Spacecraft launched in 2021, more than 1,700 were SmallSats with a mass less than 600kg. SmallSats represent more than 82% of all spacecraft launched from 2012-2021, and 16% of the total mass launched. In 2021, the SmallSat revolution was in full swing, accounting for more than 94% of all spacecraft launched. With more SmallSat and CubeSat constellations currently being planned, the demand for launch of SmallSats is expected to continually rise (1).

Since launch vehicle capability usually exceeds primary customer requirements, there is typically mass, volume, and other performance margins to consider for the inclusion of a secondary small spacecraft. Small spacecraft have an opportunity to use this surplus capacity for a potentially more cost-effective ride to space. A large market of adapters and dispensers has been created to compactly house multiple small spacecraft on existing launchers. These technologies provide a structural attachment to the launcher as well as deployment mechanisms. This method, known as “rideshare,” is still the main way of putting small spacecraft into orbit. The terms ‘rideshare’ and ‘hosted payload’ are sometimes used interchangeably, however there are distinct and subtle differences; hosted payload services offer space for a payload on a shared platform to a predetermined orbit, while rideshare services provide space for a dedicated spacecraft integrated onto the launch vehicle or separation system. For more information on hosted payloads, readers are encouraged to review the Complete Spacecraft Platforms chapter of this report.

As both SmallSat and CubeSat adapters and dispensers have become more developed, rideshares have taken on more popularity as a means to access space. Additionally, nanosatellite form factors are increasing in dimensions and mass, which require larger dispensers to accommodate these larger CubeSat sizes. Although not a new idea, using orbital maneuvering systems to deliver small spacecraft to intended orbits is another emerging technology. Several commercial companies are developing orbital tugs to be launched with launch vehicles to an approximate orbit, which then propel themselves with their on-board propulsion system to another orbit where they will deploy or serve as an integral part of their hosted small spacecraft.

Expanding future capabilities of small satellites will demand dedicated launchers. Flying the spacecraft as a dedicated payload may be the best method of ascent for missions that need a very specific orbit, near complete capability of available launcher performance, interplanetary trajectories, precisely timed rendezvous, or special environmental considerations. Technology developers and hard sciences can take advantage of the quick iteration time and low capital cost of small spacecraft to yield new and exciting advances in space capabilities and scientific understanding. The emergence of very small launch vehicles has altered the landscape by providing dedicated rides for small spacecraft to specific destinations on more flexible timelines.

NASA’s Launch Services program developed a new Indefinite Delivery/Indefinite Quantity (IDIQ) mechanism in Q1 2022: the Venture Class Acquisition of Dedicated and Rideshare (VADR) launch services. The principal purpose of the VADR IDIQ contract is to accommodate very low complexity CubeSats (up to more complex Class D missions) and provide FAA licensed launch services capable of delivering payloads to a variety of orbits. This contract mechanism provides a broad range of commercial launch services for traditional and dedicated rideshare options. The commercial approach uses a lower level of mission assurance for higher risk tolerant payloads, serving as an ideal platform for technical development that is contributing to NASA’s science and research development efforts. The 2022 Heliophysics Small Explorers Announcement of Opportunity and Mission of Opportunity are the first NASA AO’s to use this contract structure for upcoming launches. The VADR IDIQ contract provides a new mechanism for traditional and dedicated rideshare launches for risk-tolerant payloads. While the initial 13 companies have been



selected, a special on-ramp provision allows new launch services and capabilities to be proposed. (2).

The information described below is not intended to be exhaustive but provides an overview of current state-of-the-art technologies and their development status for a particular small spacecraft subsystem. It should be noted that Technology Readiness Level (TRL) designations may vary with changes specific to payload, mission requirements, reliability considerations, and/or the environment in which performance was demonstrated. Readers are highly encouraged to reach out to companies for further information regarding the performance and TRL of described technology. There is no intention of mentioning certain companies and omitting others based on their technologies or relationship with NASA.

## **10.2 State-of-the-Art – Launch Integration Role**

Launch options for a SmallSat include dedicated launch, traditional rideshare launch, or multi-mission launch, as described in the launch section below. Regardless of the approach, however, integration with the launch vehicle is a complex and critical portion of the mission. The launch integration effort for a primary spacecraft typically includes the launch service provider, the spacecraft manufacturer, the spacecraft customer, the launch range operator, and sometimes a launch service integration contractor (3). When launching on either a multi-mission or rideshare launch, the launch integration becomes even more complex.

When flying as a rideshare payload on a launch, it is generally the primary spacecraft customer who decides whether secondary spacecraft will share a ride with the primary spacecraft and, if so, how, and when the secondary spacecraft are dispensed. This is not always the case, however, as there are occasions where the launch vehicle contractor or a third-party integration company can determine rideshare possibilities. More flexibility may be available to secondary spacecraft that are funded through such a program, although the mission schedule is normally still determined by the primary spacecraft.

There are several options for identifying and booking a ride for a SmallSat. For rideshare and multi-mission launches, the spacecraft customer may choose to use a launch broker or aggregator to facilitate the manifesting, or work directly with the launch service provider. A launch broker matches a spacecraft with a launch opportunity, whereas an aggregator provides additional services related to manifesting. In the event of a dedicated launch, the spacecraft customer generally does not use a launch broker or aggregator. In both cases, however, key aspects for integration must be managed and a launch integrator can assist or coordinate those activities for the spacecraft customer.

Whether a spacecraft customer chooses to use a launch integrator or not, certification of flight is a key spacecraft responsibility. Requirements for radio frequency licensing, National Oceanic and Atmospheric Administration (NOAA) remote sensing licensing, and laser usage approval are all the responsibility of the spacecraft operator to obtain (4) (5). The launch integrator or the launch service provider will require proof of licensure before launching the satellite. They will also require additional analyses and supporting data prior to launch. This may include safety documentation, orbital debris information, materials and venting data, and spacecraft specific models (6).

For rideshare and multi-mission launches, many satellites are subject to a “do no harm” requirement to protect the primary satellite or other satellites on a multi-mission launch. A list of “do no harm” requirements are imposed on the rideshare satellite by the launch provider, launch integrator, or primary mission owner. These requirements vary by launch provider and launch integrator, but usually include restrictions on transmitters, post separation mechanical deployments, and hazardous materials. A comprehensive list of typical “do no harm” requirements is provided in TOR-2016-02946 Rev A (7).



### 10.2.1 Launch Brokers and Services Providers

A launch broker for small satellites is an individual or organization which matches a spacecraft with a launch opportunity, usually as a rideshare satellite or a multi-mission manifest spacecraft. Typically, a launch broker does not provide any additional launch integration services beyond coordinating the relationship between the spacecraft manufacturer or customer and the launch service provider. Their purpose is to fill excess capacity on a launch, and they can also bolster negotiations between the launch provider and payload for scheduling, integration, safety testing, and cost (39).

Further services can include working with the satellite customer and the launch vehicle provider to ensure that the customer's spacecraft is compatible with the launch vehicle's mission, and by performing analyses and physical integration. This service can also provide the integration hardware, such as CubeSat dispenser, separation system, or other hardware as described below, or this hardware may be provided by either the spacecraft customer or the launch services provider. It should be noted that there is no universally accepted definition of "launch broker" and the term can be used interchangeably with "launch aggregator" and "launch integrator."

## 10.3 Launch Paradigms

The SmallSat market has grown considerably over the past decade experiencing a 23% compound annual growth rate from 2009 to 2018 (10). This growth continues unabated. From 2013 to 2017 there was an average of about 140 SmallSats (less than 200 kg) launched per year. From 2017 to 2021 this number jumped to around 1700 SmallSats per year, and more than 550 SmallSats were launched in 2022. In Q2 2022, SmallSats represented 96% of spacecraft launched and 51% of the total upmass. Of these spacecraft, 200-600 kg were the most numerous type of spacecraft launched (accounting for more than 65% of total launches), while micro, nano, pico, and femto spacecraft were the next most launched spacecraft (1).

This increase in small satellite demand has caused a shift in the launch vehicle market, as well as with many companies creating or advertising launch platforms centered around small satellites. This section will detail three types of launch methods for SmallSats and the current state of these markets. While other chapters in this report cite specific companies providing "state-of-the-art" technologies, this section will provide an overview of the different types of launches available for SmallSats rather than highlighting specific companies.

### 10.3.1 Dedicated Launches

In the context of this report, dedicated launches for SmallSats are those that use launch vehicles which are generally meant to be used to launch satellites with a mass less than 180 kg. This does not mean that the maximum mass to orbit is 180 kg or less, however. For the purposes of this report, dedicated launchers will have a maximum payload of 1000 kg, as many launch vehicles being marketed for SmallSats have masses to orbit that are higher than 180 kg. The primary orbit for this type of launch is low-Earth orbit, with very few companies currently targeting highly elliptical orbit (HEO), medium-Earth orbit (MEO), or geostationary equatorial orbit (GEO). As reported in October 2019, there were 148 small launch vehicles with a maximum capability of less than 1000 kg to low-Earth orbit being tracked as current and future launch vehicles, however only eight from that list were successfully flown (11).

Dedicated launches for SmallSats have many advantages. A SmallSat on a dedicated launch controls the mission requirements in whole--what they need, when they want to launch, and where they want to go. They generally have a readiness "go / no-go" call on launch day in case something goes wrong with their satellite pre-launch. They can also request special launch



accommodations, such as a nitrogen purge or late battery charge, that are generally not available to a rideshare launch (this may be as a standard service or with an additional cost as mission-unique). The downside to a dedicated launch is that they are generally more expensive than a rideshare launch.

### **10.3.2 Traditional Rideshare Launches**

Until recently, there were only a few launchers that allowed small spacecraft to ride as primary spacecraft. The majority of small spacecraft are carried to orbit as secondary spacecraft, using the excess launch capability of larger rockets. Standard ridesharing consists of a primary mission with surplus mass, volume, and performance margins which are used by another spacecraft. Secondary spacecraft are also called auxiliary spacecraft or piggyback spacecraft. For educational small spacecraft, several initiatives have helped provide these opportunities. NASA's CubeSat launch initiative (CSLI) for example, has provided rides to a significant number of schools, non-profit organizations, and NASA centers. As of October 2022, the program launched 148 CubeSats, and continues to select CubeSats for launch (12). The European Space Agency (ESA) "Fly Your Satellite" program is a similar program which provides launch opportunities to university CubeSat teams from ESA Member States, Canada, and Slovenia (13).

From the secondary spacecraft designers' perspective, rideshare arrangements provide far more options for immediate launch with demonstrated launch vehicles. Since almost any large launcher can fit a small payload within its mass and volume margins, there is no shortage of options for craft that want to fly as a secondary spacecraft. On the other hand, there are downsides of hitching a ride. The launch date and trajectory are determined by the primary spacecraft, and the smaller craft must take what is available. In some cases, they need to be delivered to the launch provider and be integrated on the adapter weeks before the actual launch date. Generally, the secondary spacecraft are given permission to be deployed once the primary spacecraft successfully separates from the launch vehicle, but there are instances where the rideshare spacecraft separate prior to the primary satellite (14).

Multi-mission manifest launches are those that exclusively use launch vehicles to launch multiple SmallSats. These launches have shown the ability to hold and deploy dozens of satellites to multiple altitudes, though these orbits tend not to be vastly different. These types of launches are growing in popularity with many launch vehicle providers offering regular launches to the same altitude at regular intervals throughout the calendar year. While challenging, the logistics of these missions are managed by various integrators throughout the market, many of which are new to industry but are forging a new path in rideshare. Multi-mission manifest launches provide the opportunity to place large numbers of satellites into orbit on a single launch. Multi-mission manifest missions accounted for over 1500 SmallSats launched in 2021.

## **10.4 Deployment Methods**

The method by which SmallSats are deployed into orbit is a critical part of the launch process. The choice of deployment method depends on the form factor of the satellite. This section will discuss the deployment of CubeSats, which generally use CubeSat dispensers, and the deployment of free-flying SmallSats.

### **10.4.1 CubeSat Dispensers**

The CubeSat form factor is a very common standard for spacecraft up to approximately 24 kg (12U CubeSat) but can also be extended to approximately 54 kg in a 27U configuration (33). The most updated CubeSat Design Specification document is found at <http://www.cubesat.org>, a website maintained and operated by California Polytechnic State University, San Luis Obispo, the creators of the CubeSat form factor.

The CubeSat form lends itself to container-based integration systems, or dispensers, which serve as an interface between the CubeSat and the launch vehicle. It's a rectangular box with a hinged door and spring mechanism. Once the door is commanded to open, the spring deploys the CubeSat. Many companies currently manufacture dispensers for the CubeSat form factor which follow one of two constraint systems: the rail-type dispenser, and the tab-type dispenser. Due to the large number of dispenser manufacturers, the different companies are not listed here. Instead, a brief overview of the two types of dispensers is provided.

A rail-type dispenser (figure 10.1) supports CubeSats that have rails which extend the length of the CubeSat on four parallel edges. The rails on the CubeSat prevent it from rotating while inside the dispenser. After the dispenser door has been commanded to open, the rails slide along guides inside the dispenser and the CubeSat is deployed. As such, it is important that any rail-based CubeSat follow the current development specifications to ensure compliance. This type of dispenser is the most widely manufactured configuration, with more than fifteen manufacturers worldwide.

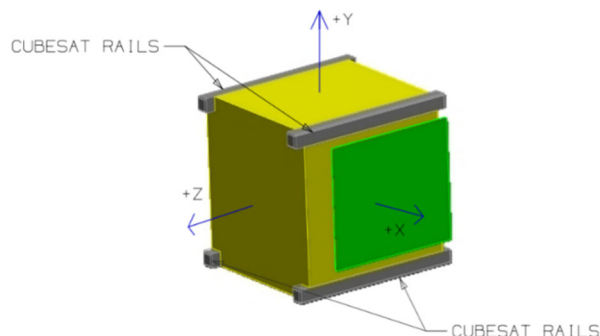


Figure 10.1: The Rail-type CubeSat. Credit: CalPoly's CubeSat Program.

A tab-type dispenser (figure 10.2) supports CubeSats with tabs which run the length of the CubeSat on two parallel edges. Typically, the dispenser grips the tabs to hold the CubeSat in place, only releasing it after the door has been commanded to open. In the past, this type of dispenser was not widely manufactured as Planetary Systems Corporation (recently acquired by Rocket Lab USA) held the patent for the design. Recently however, more developers are beginning to develop their own tab-based designs for CubeSat dispensers. There are some tab-based dispensers that do not grip the tabs. Rather, they provide a slot to accommodate the tab, which slides freely within the slot. While use of tab-type dispensers is growing, they remain a minority among dispensers purchased and used by developers.

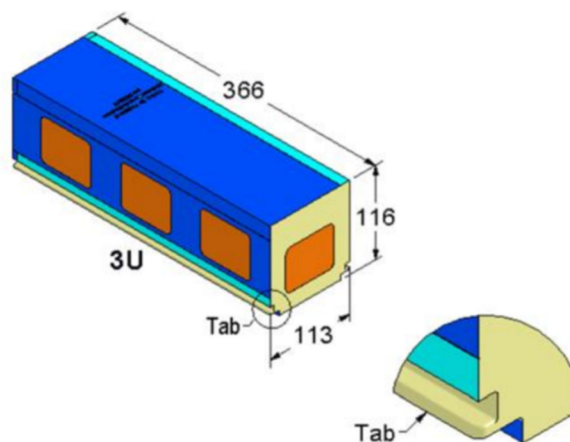


Figure 10.2: The Tab-type CubeSat. Credit: Planetary Systems Corporation.

While CubeSats can generally pick their dispenser type (rail vs. tabbed), the choice of the actual dispenser is not always a decision made by the CubeSat. In many cases, the launch vehicle provider or launch aggregator/integrator has already determined which dispensers will be installed on the launch vehicle. As each dispenser manufacturer has slightly different volumes and requirements, it is beneficial for the CubeSat to design for as wide a range of dispensers as possible to maximize launch opportunities.

Additionally, some dispenser manufacturers offer accommodations which may violate the “do no harm” requirements set forth by the launch vehicle or launch integrator, such as inhibits on



deployables and transmitters. Therefore, it is beneficial for the CubeSat to evaluate “do no harm” recommendations from a variety of organizations, as these requirements can vary from flight to flight on the same LV based on the risk posture of the primary payload and/or the mission “owner” (7).

#### 10.4.2 SmallSat Separation Systems

Small satellites which do not meet the form factor of a CubeSat, or will not be using a CubeSat dispenser for integration to the launch vehicle, require a different separation mechanism. Separation systems for SmallSats generally follow either a circular pattern or a multi-point (3 or 4 point) pattern. Depending on the launch vehicle, separation systems may already be in place and available to secondary spacecraft. It should be noted that separation systems are often some of the most complicated pieces of hardware involved with launching spacecraft. If a spacecraft is given the option to bring its own separation system to launch, great care should be taken in selection, including the development maturity and flight heritage for any separation system.

Circular separation systems use two rings held together by a clamping mechanism. One ring is attached to the launch vehicle and the other ring is attached to the spacecraft. Once the clamping mechanism is released, the two rings separate and are pushed apart by springs. Each ring then remains with the spacecraft or the launch vehicle. There are two primary types of clamping configurations, the motorized light bands (MLB) and Marman clamps.

The MLB (figure 10.3) is a motorized separation system that ranges from 8 inches to 38 inches in diameter. Smaller MLB systems are used to deploy spacecraft less than 180 kg, while larger variations may be used to separate larger spacecraft or other integration hardware such as orbital maneuvering systems, which are discussed below. The MLB’s separation system eliminates the need for pyrotechnic separation, and thus deployment results in lower shock with no post-separation debris.

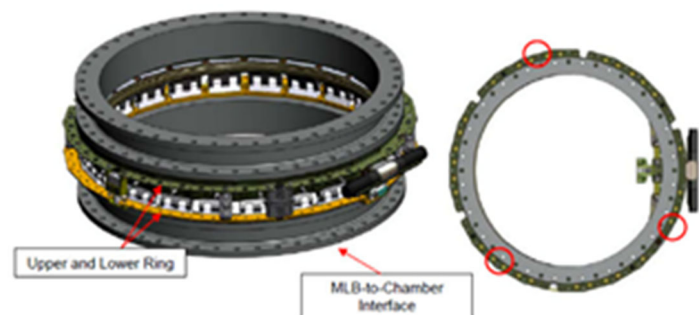


Figure 10.3: MkII Motorized Lightband. Credit: Planetary Systems Corporation.

Marman band separation systems use energy stored in a clamp band, often along with springs, to achieve separation. The Marman band is tensioned to hold the spacecraft in place. Some Marman bands use pyrotechnic devices to cut the clamping bolt, however many companies offer a low shock release mechanism which is potentially better for the spacecraft. Sierra Nevada produces a Marman band separation system known as Qwksep, which uses a series of separation springs to help deploy the spacecraft after clamp band release. RUAG Space provides several circular separation systems which use their Clamp Band Opening Device (CBOD) release mechanism to reduce shock impact on the spacecraft (15).

Several companies are now providing multi-point separation systems instead of the circular band. Using a multi-point separation system may result in mass savings over a circular separation system. However, some systems require additional simultaneous signals from the launch vehicle provider to ensure proper release. The RUAG PSM 3/8B is a low-shock separation nut developed to fit the OneWeb satellites (16). It requires additional firing commands from the launch vehicle or a dedicated sequencing system. ISISPACE has also developed the M3S Micro Satellite

Separation System (see figure 10.4) which is designed for satellites up to 100 kg but can be configured for higher masses (17).

### 10.4.3 Integration Hardware

A main driver for CubeSat utility is their adhesion to a standard that can be integrated into several different launch configurations. The physical hardware that attaches both a containerized and non-containerized small spacecraft and keeps it insulated from a rocket body include deployers, adapters, dispensers, and launchers. The purpose of this hardware is to eject the spacecraft safely into orbit, and most services offer different features, interfaces, connections, and designs for small spacecraft specifications. The exact configuration and standards vary by launch vehicle, and the determination of an appropriate and reliable launch option is part of the qualification launch process (32). With this rise in CubeSat constellation, integration hardware capable of launching multiple SmallSats simultaneously and consecutively is now a standard. This section will highlight some of the existing examples of integration flight support hardware that is applicable to both SmallSats and CubeSats, and the reader is highly encouraged to identify other integration services.

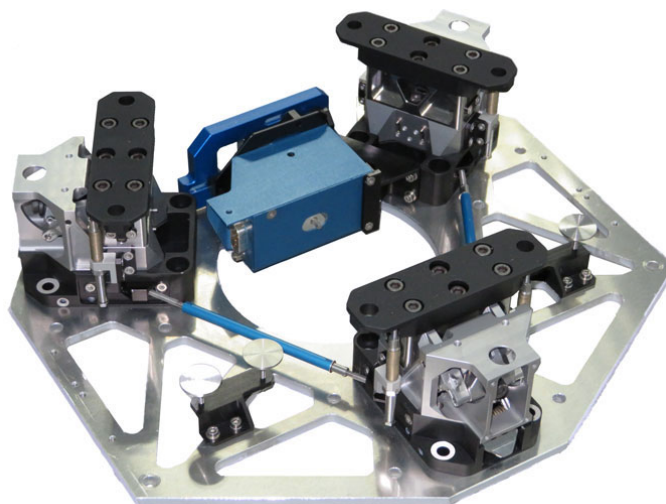


Figure 10.4: ISISPACE M3S Micro Satellite System.  
Credit: ISISPACE.

### Evolved Expendable Launch Vehicle (EELV) Secondary Payload Adapter (ESPA)

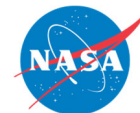
The ESPA ring (figure 10.5) is a multi-payload adapter for large primary spacecraft originally developed by Moog Space and Defense Group. Six 38 cm (15") circular ports can support six auxiliary payloads up to 257 kg each. It was used for the first time on the Atlas V STP-1 mission in 2007. The ESPA Grande (figure 10.6) uses four 61 cm (24") circular ports which can carry spacecraft up to 450 kg (991 lb) (18). Although developed by Moog, several other companies now offer similar designs in different configurations.



Figure 10.5: ESPA Ring.  
Credit: Moog, Inc.



Figure 10.6: ESPA Grande Ring.  
Credit: Moog, Inc.



### Small Spacecraft Mission Service (SSMS) Dispenser

ESA has developed the Small Spacecraft Mission Service dispenser for the Vega launch vehicle (figure 10.7). This dispenser comes in a variety of different modular parts which can be configured based on the satellite launch manifest. The modularity of the dispenser provides greater flexibility for accommodating different customers (19).

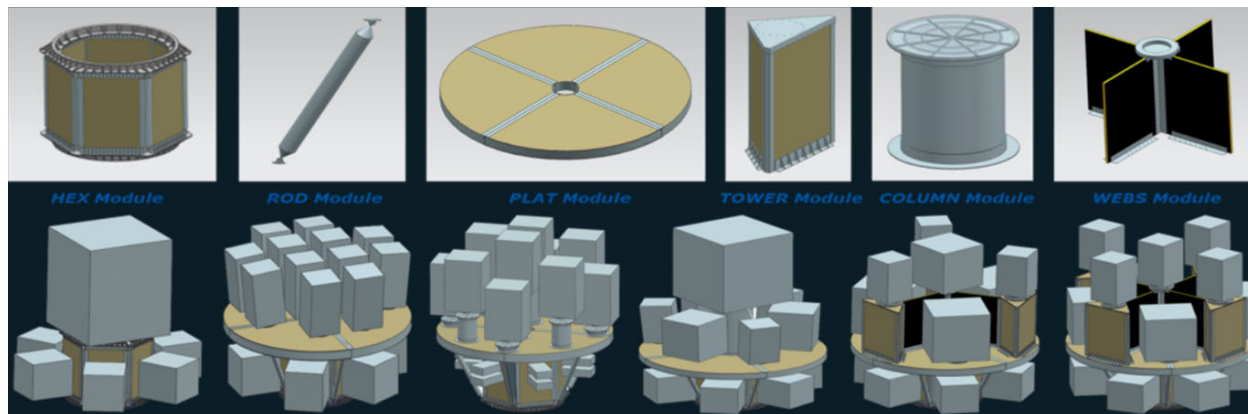


Figure 10.7: The European Space Agency Small Spacecraft Mission Service Dispenser for the Vega Launch Vehicle (19). Credit: European Space Agency.

### Dual / Multi Payload Attach Fittings (DPAF / MPAF)

Many launch vehicle providers have existing accommodations for two or more payloads which are sometimes referred to as Dual Payload Attach Fittings (DPAF) or Multi Payload Attach Fittings (MPAF). As these are generally launch vehicle specific, and occasionally mission specific, they are not discussed here.

#### 10.4.4 Orbital Maneuvering / Transfer Vehicles

One of the main disadvantages of riding as a secondary spacecraft (even on a dedicated ride-share mission) is the inability to launch into the desired orbit. The primary spacecraft determines the orbital destination, so the secondary spacecraft orbit usually does not perfectly match the customer's needs. However, by using a space tug, secondary spacecraft can maneuver much closer to their desired orbits. There are many OMVs currently planned for the market however very few if any can point to extensive flight heritage. However, this emerging technology is an area of interest in the near term for both SmallSats and CubeSats.

#### Propulsive ESPA

The ESPA Ring, discussed above, provides the structure to which SmallSats or CubeSat dispensers are mounted. However, there are several options to add propulsion to the ESPA ring to use it as a space tug.

#### Moog OMV

Moog Space and Defense has developed the Moog Orbital Maneuvering Vehicle (OMV) line of tugs (figure 10.8) which support different mission types. COMET is the baseline OMV and it can fly with several satellites mounted to it on a multi-manifest mission. Once COMET has separated from the launch vehicle, it can maneuver to reach an orbit that is more desirable for the spacecraft mounted to it. Moog has several variations on the COMET OMV for longer duration or higher-power missions (20). Moog has also developed OMVs for launch vehicles that have spacecraft interfaces smaller than 60 inches, specifically the Minotaur Orbital Maneuvering Vehicle (M-

OMV), which is packaged specifically for the Northrop Grumman Minotaur launch vehicles, and the Small Launch Orbital Maneuvering Vehicle (SL-OMV).

### Northrop Grumman ESPASStar

Northrop Grumman's ESPASStar platform (figure 10.9) is similar to the Moog COMET in that it uses an ESPA ring as part of the structure. Additionally, it provides power, pointing, telemetry, command and control for the attached satellites or payloads (21). ESPASStar was developed from the ESPA Augmented Geostationary Laboratory Experiment (EAGLE), which was developed for the Air Force Research Laboratory and was launched in April 2018. Northrop Grumman also recently launched yet another ESPASStar platform during the summer of 2022 on an AtlasV from CCSFS, marking another successful launch and deployment of this platform.

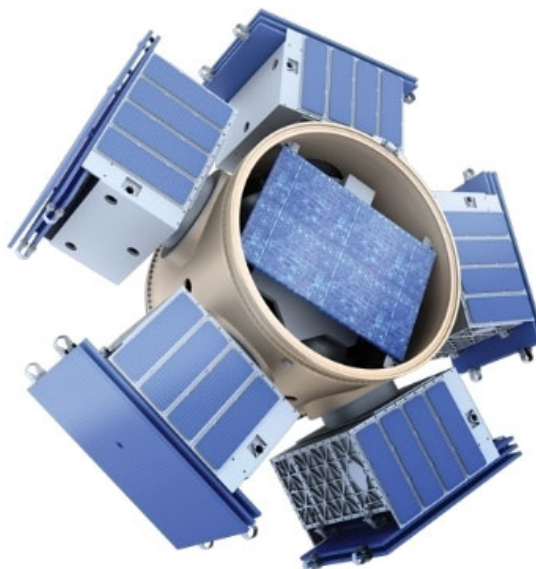


Figure 10.8: Moog OMV. Credit: Moog, Inc.



Figure 10.9: Northrop Grumman's ESPASStar Platform. Credit: Northrop Grumman.

### Spaceflight Sherpa

In addition to Moog and Northrop Grumman, Spaceflight will also offer a series of orbital transfer vehicles beginning no later than the end of 2022 (22). Spaceflight's platform, the Sherpa, is a SmallSat deployer and space tug that can host payloads. Two of the three next generation Sherpa orbital transfer vehicles are equipped with propulsion, and one is a free flyer. Both the Sherpa-FX2 and LTE1 flew on SpaceX Transporter-2 in June of 2021. The Sherpa AC-1, named for its attitude control capabilities, is a free flying satellite deployer featuring chemical propulsion that flew for the first time in May of 2022 on SpaceX Transporter-5. In addition, an updated version of the Spaceflight Sherpa the LTC-2 was launched in the Fall of 2022 on a SpaceX Transporter mission. There are currently plans for additional launches in the near term as Spaceflight continues to expand the capabilities of their Sherpa platform.

### Vigoride

Momentum Space is developing an in-space orbit transfer service for SmallSats, named Vigoride. The maximum payload mass on Vigoride is 750 kg to LEO, and it can be launched from an ESPA



or ESPA Grande ring, from ISS airlocks, or a launch vehicle. It uses water plasma engines to change the orbit prior to releasing payloads at their final orbit (23). Like all OMVs, the Vigoride is capable of changing inclination, altitude, and orbital planes. The first flight for Vigoride occurred in May of 2022, with additional launches planned for the near future.

The orbital maneuvering and transfer vehicles listed here are not an exhaustive list of all those being developed, but they provide an overview of current state-of-the-art technologies and their development status. There was no intention of mentioning certain companies and omitting others based on their technologies.

## 10.5 International Space Station Options

The International Space Station (ISS) provides several methods for deploying CubeSats and SmallSats. The sections below discuss SmallSat deployment from the ISS as well as deployment above the ISS. The ISS also accommodates hosted payloads for experiments, but those accommodations are outside the scope of this chapter as they are for individual payloads themselves and are not satellites.

### 10.5.1 Deployment from ISS

The ISS also provides several options for deploying satellites. Generally, the satellites are launched below the ISS to avoid potential contact with the ISS. Below are several options available for launching from the ISS.

#### Nanoracks ISS CubeSat Deployer (NRCSD)

Nanoracks CubeSat Deployer (NRCSD) (figure 10.10) is a self-contained CubeSat dispenser system that mechanically and electrically isolates CubeSats from the ISS, cargo resupply vehicles, and ISS crew. The NRCSD is a rectangular tube that consists of anodized aluminum plates, base plate assembly, access panels, and deployer doors. The inside walls of the NRCSD are a smooth bore design to minimize and/or preclude hang-up or jamming of CubeSat appendages during deployment, should they become released prematurely.

For deployment, the platform is moved outside via the Kibo Module's Airlock and slide table, which allows the Japanese Experimental Module Remote Manipulator System (JEMRMS) to move the dispensers to the correct orientation and provides command and control to the dispensers. Each NRCSD can hold six CubeSat units as large as a 6U (1 x 6U). The NRCSD DoubleWide can accommodate CubeSats up to 12U (2 x 6U) with Nanoracks being able to launch up to 48U per cycle. The CubeSats deploy at a 51.6° inclination, 400 – 420 km orbit 1 to 3 months after berthing at the station.



Figure 10.10: Nanoracks CubeSat Deployer. Credit: Nanoracks.

#### Nanoracks ISS MicroSatellite Deployment – Kaber Deployer Program

Nanoracks Kaber Microsat Deployer is a reusable system that provides command and control for satellite deployments into orbit from the Japanese Experimental Module Airlock Slide Table of the



ISS. The Kaber supports satellites with a form factor of up to 24U and mass of 82 kg and uses a Nanoracks separation system with circular interface similar to the separation systems discussed above. Satellites are launched to the ISS on a pressurized launch vehicle, mounted to the Kaber deployer, and deployed outside the ISS (24).

### **JEM Small Satellite Orbital Deployer (J-SSOD)**

The Japanese Experimental Module (JEM) Small Satellite Orbital Deployer (J-SSOD) is a Japanese Aerospace Exploration Agency (JAXA) developed CubeSat deployer used to launch CubeSats from the ISS. The J-SSOD can launch CubeSats up to the 6U form factor (2x3 configuration). The satellites, with their dispensers, are installed on the Multi-Purpose Experiment Platform prior to Kibo's robotic arm Japanese Experiment Module Remote Manipulator System (JEMRMS) transferring the Multi-Purpose Experiment Platform (MPEP) to the release location. At that point, the CubeSats are deployed (25).

### **Bishop Nanoracks Airlock Module**

A new airlock module, Bishop, was developed for the ISS by Nanoracks, Thales Alenia Space, and Boeing, and is the first commercialized, private module for the space station (30). Bishop provides more than five times the volume of the current Japanese Experimental Module (JEM) airlock, allowing for larger satellites and payload experiments. Bishop can host satellites and payloads, as well as deploy them, based on the needs of the mission. It has been attached to the exterior of the ISS since December 21, 2020 and has been instrumental in deploying CubeSats from the ISS (26).

## **10.5.2 Deployment Above ISS**

Regular access to the ISS is very attractive for many satellite providers. However, the lower altitude of the ISS means the in-orbit lifetime for the satellite is generally shorter. This section discusses the options that have been developed to deploy CubeSats above the ISS using a cargo resupply module.

### **Nanoracks Interchangeable CubeSat Launcher (NICL) Previously E-NRCSD**

The NICL is a system to deploy CubeSats into orbit above the ISS by using the Northrop Grumman Cygnus ISS Cargo Resupply vehicle. The first mission to use the ENRCSD was on the OA-6 mission in March 2016; the updated E-NRSD design (NICL) will have its first flight on NG-19 currently scheduled for 3/11/2023. Up to 36U of CubeSats in any form factor up to 16U can be deployed above the ISS with each Cygnus mission. CubeSats are installed in the Nanoracks deployer and mounted externally to the Cygnus vehicle before launch. They remain external to the ISS for the duration of time that Cygnus is attached to the station. The deployment altitude is dependent upon the propellant margins remaining in the Cygnus but is typically 465-500 km, meeting a minimum of 45 km above the ISS altitude (27).

### **SEOPS SlingShot**

SEOPS SlingShot is a system to deploy CubeSats into orbit above the ISS using the Northrop Grumman Cygnus ISS Cargo Resupply vehicle. The first mission to use the SlingShot was in 2019. SlingShot can fly up to 72U of CubeSats per Cygnus mission; the largest CubeSat form factor it can fly is 12U. This deployment method differs from the ENRCSD in that the satellites and their dispensers are flown to the ISS as pressurized cargo on a resupply mission. Astronauts remove the satellites and install the dispensers onto the Cygnus Passive Common Berthing Mechanism (PCBM) just prior to Cygnus' departure from the station. Once Cygnus departs the ISS, it raises to an altitude of approximately 500 km and deploys the CubeSats (28). As these CubeSats are hosted in a different location and manner than the ENRCSD CubeSats, it is possible for Cygnus to carry CubeSats in both locations on a single mission.



## 10.6 On the Horizon

### 10.6.1 Integration

From a launch broker perspective, several companies have developed online booking systems for launches similar to web-based airline ticket platforms. Some companies, including SpaceX allow one to even provide a credit card payment option for launch services (29). The premise is that you click on your preferred destination and timeline and the website provides you with launch options. As the supply of launches increases, there will most likely be an increase in demand for this type of service.

### 10.6.2 Launch

As discussed in the launch section above, there are always several new launch vehicles in development. The number continues to grow every year, and how many become realized remains to be seen.

### 10.6.3 Deployment

There are several emerging capabilities in the area of SmallSat deployment. They consist of CubeSat dispensers, SmallSat separation systems, and orbital maneuvering and transfer vehicles. The technologies listed here are not a comprehensive list.

## 10.7 Summary

A wide variety of integration and deployment systems exist to provide access to space for small spacecraft. While leveraging excess LV performance will continue to be profitable into the future, dedicated launch vehicles and new integration systems for small spacecraft are becoming popular. Dedicated launch vehicles take advantage of rapid integration and mission design flexibility, enabling small spacecraft to dictate mission parameters. New integration systems will greatly increase the mission envelope of small spacecraft riding as secondary spacecraft. Advanced systems may be used to host secondary spacecraft in-orbit, to increase mission lifetime, expand mission capabilities, and enable orbit maneuvering. In the future, these technologies may yield exciting advances in space capabilities.

The previous few years have shown an increase in the number of available launch vehicles dedicated to small spacecraft. Additionally, the CubeSat Design Specification (CDS) has been revised to include the nanosatellite classification to 12U (31), which has led to the design of dispensers that can be accommodated on a variety of launch vehicles. Regardless of the evolution of the CDS, the dispenser and bus market is symbiotic and seems to be expanding.

For feedback solicitation, please email: [arc-sst-soa@mail.nasa.gov](mailto:arc-sst-soa@mail.nasa.gov). Please include a business email.

## References

- (1) Bryce and Space Technology. "SmallSat by the Numbers, 2022." [Online] [Accessed: September 28, 2022]. Available at: [https://brycetek.com/reports/report-documents/Bryce\\_SmallSats\\_2022.pdf](https://brycetek.com/reports/report-documents/Bryce_SmallSats_2022.pdf)
- (2) NASA. "13 Companies to Provide Venture Class Launch Services for NASA," Jan 26, 2022. [Online] Available at: <https://www.nasa.gov/press-release/13-companies-to-provide-venture-class-launch-services-for-nasa>
- (3) AIAA. AIAA R-099-2001. Recommended Practice Space Launch Integration. American Institute of Aeronautics and Astronautics, Reston, VA, 2001.



- (4) E.M. Sims and B.M. Braun. "Navigating the Policy Compliance Roadmap for Small Satellites." s.l.: The Aerospace Corporation, November 2017.
- (5) Department of Defense. DoD Instruction 3100.11: Management of Laser Illumination of Objects in Space. 2016.
- (6) California Polytechnic State University, San Luis Obispo (Cal Poly) CubeSat Systems Engineer Lab. CubeSat 101 Basic Concepts and Processes for First-Time CubeSat Developers. s.l.: NASA CubeSat Launch Initiative, October 2017.
- (7) A. Read et al. "Rideshare Mission Assurance and the Do No Harm Process." s.l. : The Aerospace Corporation, February 28, 2019.
- (8) S. Kenitzer. "Three, Two, One .... Liftoff - GSA Adds Commercial Space Launch Integration Services to Schedules." [Online] March 30, 2016. Available at: <https://interact.gsa.gov/blog/three-two-one-%E2%80%A6-liftoff-gsa-adds-commercial-space-launch-integration-services-schedules>
- (9) US General Services Administration. "GSA Professional Services Schedule Space Launch Integrated Services (SLIS) Implementation Guide." March 16, 2016.
- (10) M. Puteaux and A. Najjar. Analysis | Are smallsats entering the maturity stage? SpaceNews. [Online] August 6, 2019. Available at: <https://spacenews.com/analysis-are-smallsats-entering-the-maturity-stage/>.
- (11) D. Werner. "How many small launch vehicles are being developed? Too many to track!" SpaceNews. [Online] October 24, 2019. Available at: <https://spacenews.com/carlos-launch-vehicle-update-iac/>
- (12) D. Hill. "The CubeSat Launch Initiative Celebrates its 100th CubeSat Mission Deployment." [Online] February 19, 2020. Available at: <https://www.nasa.gov/feature/the-cubesat-launch-initiative-celebrates-its-100th-cubesat-mission-deployment>
- (13) "New CubeSat Missions Selected for the Third Cycle of Fly Your Satellite." [Online] 02 03, 2020. Available at: [https://www.esa.int/Education/CubeSats\\_-\\_Fly\\_Your\\_Satellite/New\\_CubeSat\\_missions\\_selected\\_for\\_the\\_third\\_cycle\\_of\\_Fly\\_Your\\_Satellite](https://www.esa.int/Education/CubeSats_-_Fly_Your_Satellite/New_CubeSat_missions_selected_for_the_third_cycle_of_Fly_Your_Satellite)
- (14) S. Erwin. "Air Force cubesat successful deployed from Atlas 5 upper stage." Spacenews. [Online] August 08, 2019. Available at: <https://spacenews.com/air-force-cubesat-successfully-deployed-from-atlas-5-upper-stage/>
- (15) RUAG. "Payload Adapter Systems for EELV." [Online] Available at: [https://www.ruag.com/sites/default/files/2016-11/payload\\_adapter\\_system\\_for\\_EELV.pdf](https://www.ruag.com/sites/default/files/2016-11/payload_adapter_system_for_EELV.pdf)
- (16) RUAG. "Separation Nut PSM 3/8B." [Online] Available at: [https://www.ruag.com/sites/default/files/media\\_document/2019-03/Separation%20Nut%20PSM%2038B.pdf](https://www.ruag.com/sites/default/files/media_document/2019-03/Separation%20Nut%20PSM%2038B.pdf)
- (17) ISISPACE. "M3S Micro Satellite Separation System." [Online] Available at: [https://www.isispace.nl/wp-content/uploads/2018/09/M3S\\_Flyer.pdf](https://www.isispace.nl/wp-content/uploads/2018/09/M3S_Flyer.pdf)
- (18) Moog. "ESPA Overview." [Online] <https://www.csaengineering.com/products-services/espa.html>
- (19) European Space Agency. SSMS modular parts. [Online] Available at: [https://www.esa.int/ESA\\_Multimedia/Images/2019/06/SSMS\\_modular\\_parts#.XuOX3YQCe7o.link](https://www.esa.int/ESA_Multimedia/Images/2019/06/SSMS_modular_parts#.XuOX3YQCe7o.link)





- (20) Moog. The Orbital Maneuvering Vehicle. [Online] Available at: <https://www.moog.com/markets/space/omv.html>
- (21) D. Messier. "Orbital ATK Awarded USAF Contract for Long-Duration Propulsion ESPA Spacecraft." Parabolic Arc. [Online] December 12, 2017. Available at: <http://www.parabolicarc.com/2017/12/12/orbital-atk-awarded/>
- (22) Henry, Caleb: "Spaceflight Planning Three Sherpa Launches in 2021." Spacenews.com. [Online] Aug. 20, 2020. Available at: <https://spacenews.com/spaceflight-planning-three-sherpa-launches-in-2021/>
- (23) Momentus. Vigoride User's Guide V1.0. [Online] February 23, 2020. Available at: <https://momentus.space/site/wp-content/uploads/2020/02/Momentus-Vigoride-Users-Guide.pdf>.
- (24) Nanoracks. Kaber Nanoracks ISS Microsatellite Deployment System. [Online] Available at: <https://nanoracks.com/wp-content/uploads/NRMSD-overview.pdf>.
- (25) JAXA. JEM Small Satellite Orbital Deployer (J-SSOD). [Online] <https://iss.jaxa.jp/en/kiboexp/jssod/>.
- (26) A. Thompson. "The International Space Station is now home to the world's 1st commercial airlock". December 23, 2020. Accessed July 9, 2021. Available at: <https://www.space.com/nanoracks-bishop-airlock-installed-space-station>
- (27) Nanoracks. External Cygnus Deployment. [Online] Available at: <https://nanoracks.com/products/external-cygnus-deployment/>
- (28) NASA. SlingShot. [Online] Available at: [https://www.nasa.gov/mission\\_pages/station/research/experiments/explorer/Facility.html?#id=7847](https://www.nasa.gov/mission_pages/station/research/experiments/explorer/Facility.html?#id=7847)
- (29) J. Foust. "Options Grow For Smallsats Seeking Secondary Payload Opportunities." SpaceNews. [Online] August 17, 2017. Available at: <https://spacenews.com/options-grow-for-smallsats-seeking-secondary-payload-opportunities/>
- (30) N. Natario. "Commercial Space Companies In Houston Looking Forward To SpaceX Launch." [Online] May 26, 2020. Available at: <https://abc13.com/society/commercial-space-companies-looking-forward-to-spacex-launch-/6213469/>.
- (31) The CubeSat Program, Cal Poly SLO. CubeSat Design Specification (CDS) Rev 14. San Luis Obispo, California, July 14, 2020.
- (32) E.S. Nightingale, L.M. Pratt, and A. Balakrishnan. "The CubeSat Ecosystem: Examining the Launch Niche (Paper and Presentation)". IDA Science and Technology Policy Institute. December 2015.
- (33) The CubeSat Program. "Cubesat Design Specification Rev 14.1." Cal Poly San Luis Obispo, CA. 2022



## Chapter Contents

Chapter Glossary .....	ii
11.0 Ground Data Systems & Mission Operations .....	266
11.1 Introduction .....	266
11.2 Ground Systems Architecture .....	267
11.2.1 Types of Communication Infrastructures .....	268
11.3 Frequency Considerations .....	269
11.3.1 Frequency Selection: Link Budget .....	270
11.3.2 Frequency Licensing .....	270
11.4 Ground Segment Services .....	271
11.4.1 Ground Networks – NASA and Partners .....	273
11.4.2 Ground Segment as a Service (GSaaS) .....	280
11.4.3 Space Relay Network - NASA .....	287
11.4.4 Low Latency, Low rate (Short burst) Space Relay Providers .....	288
11.5 Ground Stations Components .....	289
11.5.1 Ground Station Operation .....	289
11.5.2 Component Hardware for Ground Systems (GS) .....	291
11.5.3 Ground Software .....	295
11.6 Mission and Science Operations Centers .....	299
11.6.1 Software for Mission Operations .....	301
11.7 End-to-End Communications and Compatibility Testing .....	302
11.7.1 End-to-End Hardware for Ground Systems .....	303
11.8 Cyber Security .....	308
11.9 State-of-the-Art – Ground Data and Supporting Systems .....	310
11.9.1 Technologies .....	310
11.9.2 Ground Aggregators .....	312
11.9.3 Scheduling and Mission Operations Software .....	316
11.10 On the Horizon .....	321
11.10.1 Free Space Optical Communications .....	322
11.10.2 Optical Ground Stations and Future Infrastructure Requirements .....	323
11.10.3 Techniques to Improve Optical Comm Reliability .....	329
11.10.4 Role of Optical Relays .....	330
Summary .....	330
References .....	331



## Chapter Glossary

(API)	Application Programming Interface
(ASGS)	ASRF SmallSat Ground Station
(ASRF)	Atmospheric Sciences Research Facility
(AWS)	Amazon Web Services
(C-STIS)	Celestia Satellite Test & Simulation BV
(C2)	Command & Control
(CCSDS)	Consultative Committee for Space Data Systems
(CDMA)	Code Division Multiple Access
(CPAW)	Collection Planning and Analysis Workstation
(CRC)	Cooperative Centre
(CS)	Commercial Services
(DIU)	Department of Defense's Defense Innovation Unit
(DLR)	German Aerospace Center
(DSN)	Deep Space Network
(DSOC)	Deep Space Optical Communications
(DSS-17)	Deep Space Station-17
(DTE)	Direct-to-Earth
(DVB-S2)	Digital Video Broadcast Satellite Second Generation
(EDUs)	Engineering Development Units
(EGSE)	Electrical Ground Support Equipment
(EIRP)	Effective Isotropic Radiated Power
(ESA)	European Space Agency
(ESOC)	European Space Operations Centre
(FCC)	Federal Communications Commission
(FDMA)	Frequency Division Multiple Access
(FEP)	Front End Processors
(FFRDCs)	Federally Funded Research and Development Centers
(GBPA)	Ground-Based Phase Array
(GEO)	Geosynchronous Equatorial Orbit
(GNSS)	Global navigation satellite system
(GPS)	Global Positioning System
(GSOC)	Global Security Operations Center
(GSFC)	Goddard Space Flight Center



(HEO)	Highly Elliptical Orbit
(HF)	High frequency
(I&T)	Integration and Test
(IARU)	International Amateur Radio Union
(IDL)	Interactive Data Language
(IMEI)	International Mobile Equipment Identity
(INCOSE)	International Council on Systems Engineering
(INNOVA)	IN-orbit and Networked Optical Ground Stations Experimental Verification Advanced Testbed
(ISO)	International Organization for Standardization
(ISS)	International Space Station
(ITOS)	Integrated Test and Operations System
(ITU)	International Telecommunications Union
(JPL)	Jet Propulsion Laboratory
(KSAT)	Kongsberg Satellite Services AS
(KSC)	Kennedy Space Center
(LADEE)	Lunar Atmosphere and Dust Experiment Explorer
(LCRD)	Laser Communications Relay Demonstration
(LDT)	Lowell Discovery Telescope
(LEOP)	Launch and Early Orbit Phase
(LLCD)	Lunar Laser Communications Demonstration
(LNA)	Low-Noise Amplifier
(MCS)	Mission Control Software
(MEO)	Medium Earth Orbits
(MOC)	Mission Operations Center
(MSFC)	Marshall Space Flight Center
(MSPA)	Multiple Spacecraft Per Aperture
(NEN)	Near Earth Network
(NSN)	Near Space Network
(NICT)	National Institute of Information and Communications Technology
(NIMO)	Networks Integration Management Office
(NIST)	National Institute of Standards and Technology
(NORAD)	North American Aerospace Defense Command
(NTIA)	National Telecommunications and Information Administration



(OCTL)	Optical Communications Telescope Laboratory
(OGS)	Optical ground stations
(PNT)	Position Navigation and Timing
(PPM)	Pulse Position Modulation
(PPP)	Public-Private Partnership
(PPS)	Precise Positioning System
(R&D)	Research and Development
(RF)	Radio Frequency
(SA)	Single Access
(SDR)	Software Defined Radio
(SETH)	Science Enabling Technology for Heliophysics
(SFCG)	Space Frequency Coordination Group
(SMA)	S-band multiple access
(SN)	Space Network
(SNSPD)	Superconducting Nanowire Single Photon Detector
(SOC)	Science Operations Center
(SPD-5)	Space Policy Directive 5
(SSBV)	Satellite Services B.V.
(SSC)	Swedish Space Corporation
(SWaP)	Size, Weight, and Power
(TDMA)	Time-Division Multiple Access
(TDRS)	Tracking and Data Relay Satellites
(TDRSS)	Tracking and Data Relay Satellite System
(TLE)	Two-Line Element set
(TNC)	Terminal Node Controller
(TNO)	The Netherlands Organization
(TOGS)	Transportable Optical Ground Station
(TT&C)	Telemetry, Tracking and Control
(UHF)	Ultra-High Frequency
(USRP)	Universal Software Radio Peripheral
(VHF)	Very high frequency
(VICTS)	Variable Inclination Continuous Transverse Stub
(VMs)	Virtual Machines
(WFF)	Wallops Flight Facility



## 11.0 Ground Data Systems & Mission Operations

### 11.1 Introduction

The ground segment is a critical part of the end-to-end science data return, and it includes all the ground-based elements that are used to collect and disseminate information from the satellite to the user (figure 11.1). The primary elements of a ground system are summarized in table 11-1.

There are exciting changes in the government and commercial sector ground stations and services, and the shifting synergy between these. From its inception in 1958, whenever NASA needed to receive data from one of its Earth observing satellites or talk to its astronauts in orbit, it used equipment and services it had needed to develop and build itself. Over time, commercial enterprise acquired the proficiencies necessary to reliably and securely communicate with objects in low-Earth orbit (LEO), services NASA is now pursuing to purchase as any other near-Earth space customer.

The agency combined NASA’s Near Earth Network (NEN) and NASA’s Space Network (SN) into NASA’s Near Space Network (NSN) in October of 2020. To support the commercialization initiative, NASA plans to have increased reliance on industry-provided communications services for missions close to Earth by 2030 (59). As of 2022, commercial providers do not service the Sun-Earth Lagrange Points or Deep Space, thus the Deep Space Network (DSN), and large NSN assets (18 m) continue to play a critical and needful role in returning science data from these regions for Heliophysics, Astrophysics and Planetary Science directorates.

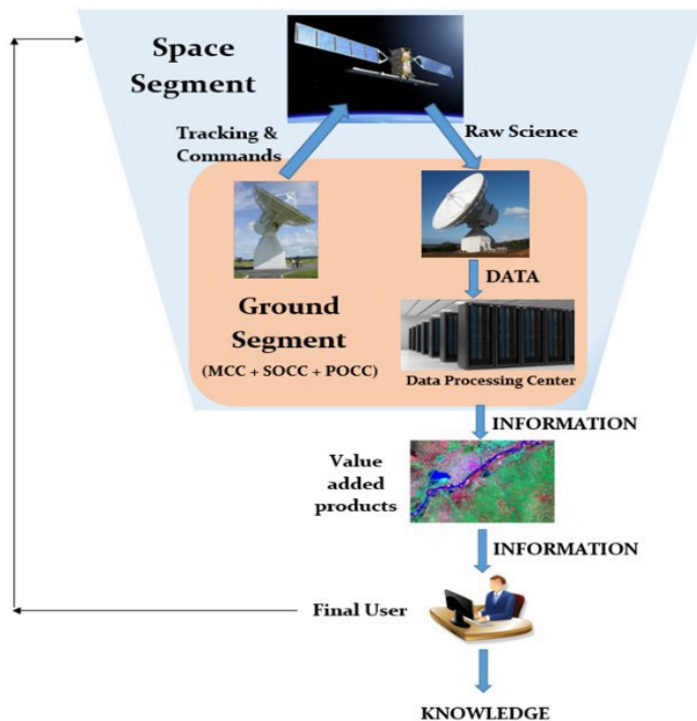


Figure 11.1: Functional relationship between the space segment, ground segment and final user for a small satellite mission. Credit: NASA.

Table 11-1: Primary Elements of a Ground System	
Element	Function
Ground Stations	Telemetry, tracking, and command interface with the spacecraft
Ground Networks	Connection between multiple ground elements
Control Centers	Management of the spacecraft operations
Remote Terminals	User interface to retrieve transmitted information for additional processing



The NSN provides Direct-to-Earth (DTE) services via a global system of commercial and NASA-owned ground stations that provide line of sight communications and tracking services to missions ranging from low-Earth orbit and extending to Sun-Earth Lagrange Points 1 & 2. These services are augmented by Space Relay services via relay satellites in geosynchronous orbit.

The ground segment design can depend on several factors which may include, but are not limited, to the following:

- Data volume to satisfy mission requirements
- Location of the ground assets relative to mission orbit parameters
- Budget limitations
- Distribution of the team
- Affiliation of who controls the spacecraft (federal vs. non-federal users)
- Regulatory requirements
- Latency requirements

The ground system is responsible for collecting and distributing the most valuable asset of the mission: the data. Using the proper ground system is key to mission success.

All small satellites use some form of a ground segment to communicate with the spacecraft, whether it be hand-held radios using an amateur frequency, or a large dish pulling down data on a non-federal or federal frequency. The commercial marketplace for Telemetry, Tracking and Commanding (TT&C) services continues to expand and has reached a maturity to enable commercialization of Direct-to-Earth (DTE) radio frequency communications services. NASA is encouraging a growing commercial market by leveraging commercial capabilities to increase efficiency and robustness of ground networks. In addition, NASA plans to enhance its communications capabilities to provide near-continuous communications support to the Artemis lunar missions through Communication Relay and Navigation services in Lunar space.

## 11.2 Ground Systems Architecture

A typical small satellite mission has the following elements within the ground system architecture:

- Ground Station Terminal: Transmitter and receiver or transceiver at the ground station to transmit and receive information, including related hardware such as antennas. These may be in a Radio Frequency (RF) or in an optical wavelength.
- Mission Operations Center (MOC):
  - Commands the spacecraft
  - Monitors spacecraft performance
  - Requests and retrieves data as necessary
- Science Operations Center (SOC):
  - Generates and disseminates science data products
  - Determines science operations to be relayed to the MOC
- Ground Station Data Storage and Network:
  - Provides live connectivity to a MOC for commands and telemetry
  - Temporarily stores data to be retrieved by the MOC and/or SOC

Figure 11.2 shows a generic small satellite ground architecture that uses NASA's Near Space Network (NSN) for nominal ground passes and the NASA Space Network (SN) for low-latency messaging.

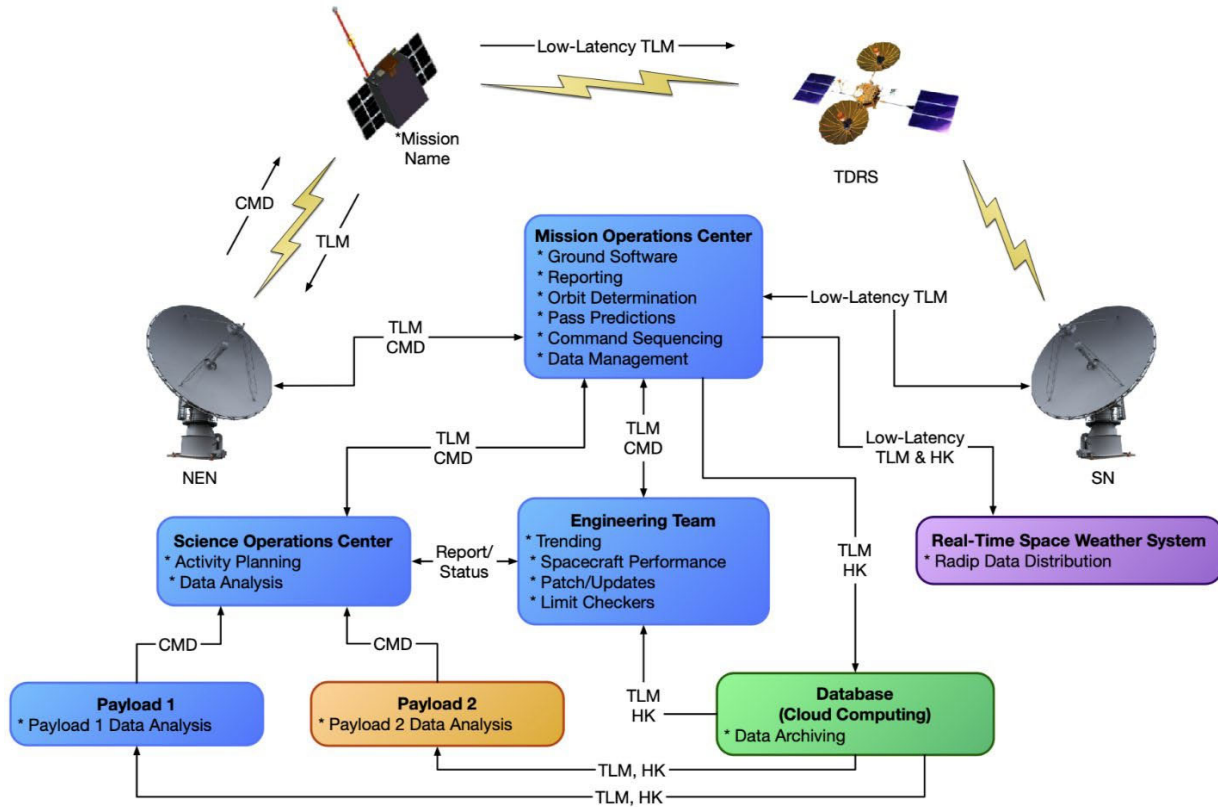


Figure 11.2: Example of a ground system architecture for a small satellite using NASA's Near Space Network. Credit: NASA.

In this architecture, the MOC is responsible for all communication to and from the spacecraft, while the SOC and engineering teams can work both directly through the MOC to process commands. This is especially helpful during commissioning and troubleshooting instances where the engineering team needs direct access to the flight system. This architecture also provides a separate database generated from the MOC of telemetry and housekeeping data that is accessible to stakeholders.

### 11.2.1 Types of Communication Infrastructures

Communications services may be either Direct-to-Earth (DTE) or augmented by space relay. DTE ground stations provide direct point-to-point access with antennas at ground stations which are strategically located and equipped with telemetry, command, and tracking services. DTE antennas for NASA small satellites are high gain parabolic dish antennas used to support S, X, and Ka bands, while some universities still use parabolic or UHF Yagi antennas. DTE ground stations could also incorporate phased array antenna systems or equipment for optical communications. The DTE services are especially effective for missions needing frequent, short-duration contacts with high data throughput. They are also capable of handling longer latency durations due to orbital dynamics and station visibility.

Space relay services involve an intermediate satellite that communicates with a ground station on the Earth's surface. Relay communication satellites for low-Earth orbit spacecraft can be in Geosynchronous Equatorial Orbit (GEO), about 36,000 km from Earth, or in low-Earth orbit. Relays are essential for providing communication and tracking when direct-to-ground communications are not feasible due to physical asset visibility constraints. It is common for a low-Earth orbit spacecraft to only be in a DTE ground station's line of sight for a portion of the orbit. The addition of space-





based relay assets can provide missions with full-time coverage and continuous access to communication and tracking services. They are most useful for missions that need continuous coverage, low latencies, and coverage of launch, critical events, or emergencies.

Communication with DTE ground stations can achieve much higher data rates than what is possible for space-based relays. When considering a GEO relay satellite, it can be ten times the distance from the low-Earth orbit spacecraft than the DTE ground station. With communication propagation losses being a function of the reciprocal of the distance squared, the same communications system can achieve orders of magnitude higher data rates with the DTE ground station. Achieving comparative data rates for a relay system would require a significant increase in power. The current low-Earth orbit relays have hardware limitations that permit data rates of 9.6 kbps or less, which is low relative to SmallSats being able to achieve 3 Mbps or more with DTE ground stations.

### 11.3 Frequency Considerations

The spacecraft transceiver and ground station need to be on a coordinated frequency to communicate. Selecting transmit and receive frequencies are a critical part of the spacecraft communications system design process. Frequencies are divided into different bands as shown in table 11-2. See a list of supported frequencies per ground station in their specific sections.

Typical bands considered for small satellites and therefore ground stations are Ultra High Frequency (UHF), S, X, and Ka. UHF was the band of choice for early small satellites, but in recent years, there has been a shift to S and X and Ka. A ground station needs to maintain antennas and receivers such that the ground receive matches the space segment's transmit frequency and vice versa. Since Transmit (Tx) and Receive (Rx) have different key drivers and requirements, many ground stations are dual or tri-band.

#### Ground Station Receive (Spacecraft Return, Telemetry)

Ground station receive frequencies are mostly S and X band from a LEO/ GEO orbit, and X and Ka band from deep space. Ka band has been implemented for transmit and is NASA's desired band for future small satellite missions. This shift has been driven by higher data return demands and frequency control. The higher frequencies permit more data to be transmitted over a given period but require more stringent pointing. UHF is appealing to some universities, due to the lower cost of hardware for both the spacecraft and ground station, good link margins, and more omnidirectional pattern capability with the spacecraft but yields lower data rates and has a higher probability for interference. Higher frequencies provide wider bandwidths, and the matching antennas have narrower beamwidths or are arrayed for a higher gain, thus more stringent pointing is required.

#### Ground Station Forward (Spacecraft Commanding)

The key driver to successfully command a satellite from the ground, is the ability to reach it. The most critical period is after a satellite's release from the launch vehicle, at which point the satellite does not yet have full control over its attitude, thus the most important thing is a wide beamwidth for the spacecraft receiving antenna(s) in the selected frequency. For this reason, ground stations

<b>Band</b>	<b>Frequency</b>
HF	3 to 30 MHz
VHF	30 to 300 MHz
UHF	300 to 1000 MHz
L	1 to 2 GHz
S	2 to 4 GHz
C	4 to 8 GHz
X	8 to 12 GHz
Ku	12 to 18 GHz
Ka	27 to 40 GHz
V	40 to 75 GHz
W	75 to 110 GHz
mm	110 to 300 GHz



are designed with more power and Low Noise Amplifiers (LNA) to counter the low gain, ideally omni-directional single patch receive antennas in the lower frequency bands.

### 11.3.1 Frequency Selection: Link Budget

Calculating the RF link budget is the first step when designing a telecommunications solution. It is a calculation of the end-to-end performance of the communications link with the constraint of maintaining a required link margin. Maintaining a 3 dB link margin is adequate for data return from a satellite in low-Earth orbit at a slant range of 1,500 km. Usually commanding to a Near Earth orbit has plenty of margin because of the high power and aperture size of the ground station, and the lower required data rate on the account of the commands' low volume. When considering deep space communication, a 3 dB link margin is desired, but for distant spacecraft, such as New Horizons at 7 billion kilometers from Earth, 1 dB or less margin may be all that is practically possible. The budget calculation adds and subtracts all the power gains and losses that a communication signal will experience within the system. Factors such as uplink amplifier gain and noise, transmit antenna gain, slant angles and corresponding free space loss, satellite transceiver noise levels and power gains, receive antenna and amplifier gains and noise, cable losses, and atmospheric attenuation are considered. There is a duality to frequency effects: free space loss over the same range is less for lower frequencies; however, the wavelength is much smaller for higher frequencies, thus a same size ground aperture provides a much higher Gain over temperature (G/T). On the spacecraft end, a multi-element high-gain Ka-band antenna array for example fits in the palm of a hand. For high volume data return, which is where communications bottlenecks occur, higher frequencies are desirable – all the way up to optical wavelengths at 1550 nm (see section 11.10.1, Free Space Optical Communications).

### 11.3.2 Frequency Licensing

RF communication frequencies are intentionally protected. Within each frequency band there are government and non-government designations amongst the frequencies. Some frequencies are government use only, others are non-government only, and some are shared. Government bodies that regulate the frequency usage in the United States are the Federal Communications Commission (FCC) and the National Telecommunications and Information Administration (NTIA). Other countries may have their own national governing bodies, and all national bodies around the world must coordinate with the International Telecommunications Union (ITU), which is the governing body at the international level. The FCC is responsible for issuing communications licenses to non-government users and the NTIA handles government users. Licenses are required for both the satellite and ground station to transmit on a designated frequency or frequencies. It is becoming more common for small satellites to use multiple bands. For example, some missions have used UHF for uplink and S- band for downlink, while others have used S-band for uplink and X-band for downlink. Some of the non-government frequencies are dedicated for amateur usage.

Early university small satellites relied heavily on the use of amateur frequency bands. In recent years, there has been movement by the International Amateur Radio Union (IARU) and the FCC to significantly limit the use of amateur frequencies for small satellites. Those interested in using these frequencies are expected to first communicate their intention with the IARU and obtain a coordination letter prior to submitting an application with the FCC. It is recommended that missions with a new communication system design apply with the FCC or NTIA once an operations concept and a spacecraft design are defined, in order to verify a proper communications approach and associated hardware has been selected. Missions using a legacy communications approach can typically wait until they have been given a launch manifest. The licensing process can take several months and needs to be completed prior to launch. Some of the processing time is associated with the FCC and NTIA having to also coordinate with the ITU. Both the FCC and ITU are working to implement more streamlined small satellite licensing options. Such improvements will be



necessary as constellations of small satellites become more prevalent.

#### 11.4 Ground Segment Services

Ground segment services may include the below four categories. The NSN is a full-service ground station network and offers all four major service categories. Not all commercial services offer all services.

- 1) Mission Integration – this includes development of service agreements, interfaces, documentation, support of reviews, etc.
- 2) Mission Planning and Scheduling – this includes performing link and loading analyses, supporting service requests, and generating and implementing operational schedules.
- 3) User Mission Data Transfer – this includes primarily spacecraft forward command and return telemetry data.
- 4) Position, Navigation and Timing (PNT) – this includes navigation.

Position information (4) is critical for commanding the spacecraft (3). Commanding may be scripted by the mission and is actuated through ground services. Challenges are usually associated with the initial satellite-to-ground station link closure. Typically, two-line elements (TLE) or state vectors are established and shared by the launch provider after deployment. This information can be used to create an initial orbit solution for ground station antenna pointing. Low-Earth orbit missions can use North American Aerospace Defense Command (NORAD) TLE data (see <https://www.space-track.org>) for satellite location. However, it could take up to a week or more for NORAD to add the new object to their tracking list. This process could be delayed further if multiple spacecraft are ejected in close proximity, and it may not be clear which NORAD element set corresponds to which spacecraft. It is not uncommon to spend weeks attempting contact with different NORAD-tracked objects until the correct one is found. The position prediction accuracy based on the NORAD TLE also diverges over time and a new TLE will be needed to maintain data link. This is typically not an issue since the TLE is updated regularly, but on-board Global Positioning System (GPS) data (if equipped) can help determine the orbital parameters for the ground station to define latest orbital parameters.

Another method is to locate the satellite as it rises from the horizon. Ground station operators can point a directional antenna 5-10 degrees above the horizon to detect the satellite and synchronize with the radio. Most antenna tracking software will commence automatic tracking after the initial acquisition is successful. A half-duplex or full-duplex system could make a difference as well. Program track instead of auto-track is used for half-duplex. With a full-duplex system, the ground antenna attempts to acquire the downlink first. Predicts (NORAD or state vectors) are still used to initially acquire the spacecraft. If the predicts are off, the antenna can initiate a mechanical scan to increase the search area. Once the downlink is acquired, the ground antenna can auto-track and automatically point at the satellite for the duration of the pass. Additional passes are scheduled during spacecraft and payload commissioning. Table 11-3 describes NSN's transport and tracking capabilities.



<b>Table 11-3: NSN Interfaces and Capabilities</b>		
<b>Interface/ Capability<sup>1</sup></b>	<b>Direct to Earth</b>	<b>Space Relay</b>
<b>Terrestrial Link Data Transport Capabilities</b>		
Data Storage <sup>1</sup>	Station Storage: 5-30 days Cloud-based: Mission-driven	7 days
Network Data Rate <sup>1</sup>	Mission-driven (up to 1.2 Gbps)	
SLE Protocols	F-CLTU, EF-CLTU (Forward) RAF, RCF, ROCF (Return)	
SLE Versions Supported <sup>2</sup>	CCSDS 910.4, CCSDS 911.1, CCSDS 911.2, CCSDS 911.5, CCSDS 912.1, CCSDS 912.11, CCSDS 912.3, CCSDS 913.1	
Offline-Data Transfer	CFDP, SFTP	
Security	Trusted Networks (Access Controls, Firewalls, Authentications, etc.)	
<b>Spacecraft Navigation Tracking Capabilities</b>		
Radiometric Tracking Services <sup>1</sup>	Tone Ranging 1-way or 2-way Doppler Antenna Angle Data	Spread Spectrum Ranging 1-way or 2-way Doppler Antenna Angle Data
Radiometric Measurement Accuracy <sup>1</sup>	<u>Range:</u> S-band: < 5 meters, 1 $\sigma$ <u>Doppler (Range-Rate):</u> S-band 1-way: $\leq 30$ mm/s, 1 $\sigma$ S-band 2-way: $\leq 15$ mm/s, 1 $\sigma$ X-band 1-way: $\leq 7$ mm/s, 1 $\sigma$ Ka-band 1-way: $\leq 2$ mm/s, 1 $\sigma$ <u>Antenna Angles:</u> S: 0.03°, X: 0.05° Ka: 0.01° (auto), 0.05° (program)	<u>Range:</u> $\leq 2.73$ meters, 1 $\sigma$ <u>Doppler (Range-Rate):</u> 1-way $\leq 1.55$ mm/s, 1 $\sigma$ 2-way $\leq 3.1$ mm/s, 1 $\sigma$ <u>Antenna Angles:</u> $\leq 0.1^\circ$
Radar Tracking Service Bands	C-band (5.4-5.9 GHz) Single Object X-Band (10.499 GHz) Multi Object	N/A
Radar Tracking Loop Gain (dB)	C-Band: 212-245 (227 Typical) X-Band: 246 (nominal)	
Other <sup>1</sup>	Ground Antenna Slew Rate:	Time Transfer Measurement:
	Azimuth and Elevation: $\geq 10^\circ/\text{sec}$ ( $10^\circ/\text{sec}^2$ ) * Train: $\geq 5^\circ/\text{sec}$ ( $5^\circ/\text{sec}^2$ ) * WS1 18-m system $\geq 2^\circ/\text{sec}$ ( $1^\circ/\text{sec}^2$ )	User Spacecraft Clock Calibration System: $\leq \pm 5 \mu\text{s}$ Return Channel Time Delay: $\pm 25\%$ of a bit period

<sup>1</sup> Services and performance (Data Rates, EIRP, G/T, etc.) are not uniform across assets.

<sup>2</sup> Additional capabilities above those listed could be supported as well.

<sup>3</sup> NASA may consider adding technologies not currently on its roadmap.

<sup>4</sup> 2nd and 3rd Generation TDRS only.



Another critical time in the life of a spacecraft is commissioning; either commissioning of the spacecraft bus, or commissioning of science instruments, including in-space calibration. During commissioning phases, additional time and support personnel are typically scheduled (1).

#### 11.4.1 Ground Networks – NASA and Partners

The ground stations, MOC, SOC, and the supporting infrastructure connecting them together, make up a ground network. Ground station antenna dish diameters, Low Noise Amplifiers, frequency feeds, station gain over temperature (G/T) requirements are carefully selected for each network and are optimized for targeted ranges. NASA’s NSN ground network provides services to satellites up to 2 million km range from Earth; NASA owns and JPL maintains the DSN for missions beyond two million km, including planetary.

At NASA’s Goddard Space Flight Center, the Exploration and Space Communications (ESC) projects division oversees the operations, maintenance and advancement of the Space Communications and Navigation (SCaN) program office’s NSN. Operating at a high-level of reliability and proficiency, the NSN provides communications and navigation services for missions within 2 million kilometers of our planet, bringing down an average of almost 30 Terabytes of critical data daily. Through space relays and ground-based assets, The NSN provides data delivery and satellite tracking services, empowering new discoveries about the universe and our home planet. JPL is responsible for managing and maintaining the DSN.

#### NASA Near Space Network

“The newly established NSN is more than just an aggregation of the NEN’s and SN’s space-based technologies, ground stations and antennas; it’s the network through which NASA and other space users will now arrange for support services for their near-Earth missions. Critically, those support services may be provisioned through government or commercial network assets in a way that is seamless to users—a cornerstone in SCaN’s effort to incorporate increasing levels of commercial service while ensuring mission needs are met.” (2)

The NSN provides direct-to-earth telemetry, commanding, ground-based tracking, and data and communications services to a wide range of customers. The network consists of NASA, commercial, and partner S-band, X-band, and Ka-band ground stations supporting spacecraft in low-Earth orbit, GEO, Highly Elliptical Orbit (HEO), Lunar orbit, and Lagrange point L1/L2 orbit up to one million miles from Earth. The NSN supports multiple robotic and launch vehicle missions with NASA-owned stations and through cooperative agreements with interagency, international, and commercial services. Table 11-4 shows the radio frequencies that the NSN supports via the NTIA.

<b>Table 11-4: NSN Supported Radio Frequencies and Bandwidths</b>		
<b>Band</b>	<b>Function</b>	<b>Frequency Band (MHz)</b>
S Uplink	Earth to Space	2,025 – 2,110
X Uplink	Earth to Space	7,190 – 7,235 (Two NEN sites to 7,200)
S Downlink	Space to Earth	2,200 – 2,300
X Downlink	Space to Earth, Earth Exploration	8,025 – 8,400
X Downlink	Space to Earth, Space Research	8,450 – 8,500
Ka Downlink	Space to Earth	25,500 – 27,000



A comprehensive list of Forward and Return capabilities per frequency are in Table 11-5. Systems are compliant with most CCSDS recommendations. The NSN consists of geographically-dispersed ground stations operated by NASA and its commercial partners (figure 11.3).



Figure 11.3: NSN Global Ground Station Locations. Credit: NASA

### Government

- NASA's Alaska Satellite Facility, Fairbanks — Supports: S/X Band — Assets: 11.3m, 11m, 9.1m
- NASA's Kennedy Uplink Station — Supports: S-band - Assets: 6.1m
- NASA's Ponce de Leon Station — Supports: S-band - Assets: 6.1m
- NASA's Wallops Ground Station (GS), Virginia — VHF, S/X Band — Assets: 11m/5m
- NASA's White Sands GS, New Mexico — Supports: VHF, S/Ka Band — Assets: 18.3m
- NASA's White Sand Complex, New Mexico — Supports VHF, S/Ka Band — Assets: 11m
- NASA's McMurdo Ground Station, Antarctica — Supports: S/X Band — Assets: 10m
- Fairbanks Command and Data Acquisition Station (NOAA partnership), Gilmore Creek, Alaska

### Commercial

- KSAT Singapore — Supports: S/X Band — Assets: 9.1m
- KSAT Svalbard, Norway — Supports: S/X Band — Assets: 11.3m/11.3m/13m
- KSAT TrollSat, Antarctica — Supports: S/X Band — Assets: 7.3m/7.3m
- SANSA Hartebeesthoek, South Africa — Supports: S/X Band — Assets: 12m/10m
- SSC Kiruna, Sweden — Supports: S/X Band — Assets: 13m/13m
- SSC Santiago, Chile — Supports: S Band — Assets: 9m/12m/13m



- SSC Space US North Pole, Alaska — Supports: S/X Band — Assets: 5m/7.3m/11m/13m
- SSC Space US Dongara, Australia — Supports: S/X Band — Assets: 13m
- SSC Space US South Point, Hawaii — Supports: S/X Band — Assets: 13m/13m

<b>Table 11-5: NSN Direct to Earth Command and Telemetry Capabilities per Frequency</b>		
<b>Interface/ Capability<sup>1</sup></b>	<b>Direct to Earth</b>	<b>Space Relay</b>
<b>Forward (Command) Communications</b>		
Frequency Bands (Near-Earth Use)	S-band: 2025-2110 MHz X-band: 7190-7235 MHz	S-band: 2025-2110 MHz Ku-band: 13.775 GHz Ka-band: 22.55-23.55 GHz <sup>4</sup>
Maximum Bandwidth	S-band: 5 MHz X-band: 10 MHz	S-band: 6 MHz Ku-band: 50 MHz Ka-band: 50 MHz <sup>4</sup>
Forward Max Data Rate <sup>1,2</sup> (prior to encoding)	S-band: 5 Mbps X-band: 5 Mbps	S-band MA: 300 Kbps S-band SA: 4.2 Mbps Ku-band: 50 Mbps Ka-band SA: 50 Mbps <sup>4</sup>
Antenna System EIRP (dBW) <sup>1</sup>	S-band: 51-81 (56 Typical) X-band: 85-86	S-band MA: 42 <sup>4</sup> S-band SA: 48.5 <sup>4</sup> Ku-band SA: 48.5 <sup>4</sup> Ka-band SA: 63 <sup>4</sup>
Modulation <sup>2,3</sup>	PM, FM, PCM, PCM/PM, PCM/PSK/PM, BPSK, QPSK, OQPSK, UQPSK	Spread spectrum: BPSK or UQPSK Non-spread: BPSK, QPSK, OQPSK, PCM/PM, or PCM/PSK/PM
Encoding <sup>2,3</sup>	Uncoded, or LDPC ½ or 7/8	Uncoded, Rate ½ Conv., Reed-Solomon, Concatenated (½ Conv. + RS), LDPC ½ or 7/8
Polarization	Circular (LHC, RHC)	Circular (LHC, RHC) (LHC only for MA services)
<b>Return (Telemetry) Communications</b>		
Frequency Bands (Near-Earth Use)	S-band: 2200-2290 MHz X-band: 8025-8400 MHz X-band (SRS): 8450-8500 MHz Ka-band: 25.5 – 27 GHz <sup>4</sup>	S-band: 2200-2290 MHz Ku-band: 15.0034 GHz Ka-band: 25.25 – 27.5 GHz <sup>4</sup>
Maximum Bandwidth	S-band: 5 MHz X-band: 375 MHz X-band (SRS): 10 MHz Ka-band: 1500 MHz	S-band (MAR & SAR): 6 MHz Ku/Ka-band: 225 MHz <sup>4</sup> Ka-band (Wide): 650 MHz <sup>4</sup>



Return Max Data Rate <sup>1,2</sup> (prior to encoding)	<u>Rates will vary – examples:</u> S-band: 2.2 Mbps (PACE) X-band: 220 Mbps (ICESat-2) X-band (SRS): 13.1 Mbps (IRIS) Ka-band: 3.5 Gbps (NISAR)	S-band MA: 1 Mbps S-band SA: 14.1 Mbps Ku/Ka-band: 600 Mbps <sup>4</sup> Ka-band (Wide): 1200 Mbps <sup>4</sup>
Antenna System G/T (dBW) <sup>1</sup>	S-band: 19.1-29.6 (21 Typical) X-band: 30.5-37.8 (32 Typical) Ka-band: 38-45 (41.3 Typical)	S-band MA: 3.2 (for LEO) S-band SA: 9.5 (for LEO) Ku-band: 24.4 (for LEO) Ka-band: 26.5 (for LEO) <sup>4</sup>
Demodulation <sup>2,3</sup>	PM, FM, PCM, PCM/PM, PCM/PSK/PM, BPSK, QPSK, OQPSK, AQPSK, SQPN, 8PSK	Spread spectrum: BPSK or UQPSK Non-spread: BPSK, QPSK, OQPSK, PCM/PM, or PCM/PSK/PM
Decoding <sup>2,3</sup>	Uncoded, Rate ½ Conv. and/or Reed-Solomon, LDPC ½ or 7/8, or Turbo Rate ½	Uncoded, Rate ½ Conv., Reed-Solomon, Concatenated (½ Conv. + RS), LDPC ½ or 7/8, Rate 7/8 TPC
Polarization	Circular (LHC, RHC)	Circular (LHC, RHC) (LHC only for MA services)

<sup>1</sup> Services and performance (Data Rates, EIRP, G/T, etc.) are not uniform across assets.

<sup>2</sup> Additional capabilities above those listed could be supported as well.

<sup>3</sup> NASA may consider adding technologies not currently on its roadmap.

<sup>4</sup> 2nd and 3rd Generation TDRS only.

While NASA's NSN is often reserved for NASA-funded missions, other ground network options exist for non-government-funded satellite operators. One common option, especially amongst amateur operators, is to take advantage of the UHF and VHF amateur network around the world.

The NSN is exploring how to provide higher data rates for CubeSat missions with techniques such as Digital Video Broadcast Satellite Second Generation (DVB-S2). Higher data rates either increase science return or reduce the number of minutes per day of required ground station contacts. Higher data rates also enable mother-daughter small satellite constellations, where the mother spacecraft handles the communication with Earth for multiple daughter spacecraft. Functions such as Multiple Satellite per Aperture (MSPA) are planned to be implemented on the Lunar Exploration Ground Sites (LEGS) mission (see the State of the Art section).

The NSN facilitates Commercial Services (CS) and negotiated a bulk-buy discount for all NASA missions. This allows for contacts on the NSN Contractor/University Operated and CS apertures to be at no-cost for NASA missions. The NSN does schedule CS in accordance with NASA mission-defined priority. The Networks Integration Management Office (NIMO) at NASA GSFC is the liaison for customers that wish to use NSN services. NIMO has a variety of services and capabilities available and can coordinate support from providers throughout NASA, other US agencies, US commercial entities, and foreign governments. Some of the services that NIMO can provide include:

- Requirements Development
- Communications Design Support & Guidance





- Optical Communications Analysis
- Network Feasibility Analysis
- Spectrum Management
- RF Compatibility Testing
- Launch Support

Network Feasibility Analysis includes determining NSN station loading as a function of the mission's priority and determining the availability of planned stations for the contacts requested. Prior to the mission deployment, the NSN commits to providing the requested stations and contact time as outlined in the network feasibility analysis.

*For new customer mission service requests please fill out the NSN Service Inquiry Form at: <http://go.nasa.gov/NSNServiceInquiry>.*

*If interested in more information on using the Near Space Network (NSN), please also refer to <https://esc.gsfc.nasa.gov/projects/NSN>.*

### **NASA Deep Space Network**

The DSN is optimized to conduct telecommunication and tracking operations with space missions in GEO. This includes missions at lunar distances, the Sun-Earth LaGrange points, and in highly elliptical Earth orbits, as well as missions to other planets and beyond. The DSN has supported, or is currently supporting, missions to the Sun as well as every planet in the Solar System (including dwarf planet Pluto). Two missions (Voyager I and Voyager II) have reached interstellar space and still communicate with the DSN. The DSN offers services to a wide variety of mission customers, as shown in table 11-6.

<b>Table 11-6: DSN Customers, Mission Characteristics, Frequencies, and Services</b>	
<b>Customers</b> <ul style="list-style-type: none"> <li>• NASA</li> <li>• Other Government Agencies</li> <li>• International Partners</li> </ul>	<b>Mission Phases</b> <ul style="list-style-type: none"> <li>• Launch and Early Orbit Phase (LEOP)</li> <li>• Cruise</li> <li>• Orbital</li> <li>• In-Situ</li> </ul>
<b>Mission Trajectories</b> <ul style="list-style-type: none"> <li>• Geostationary or GEO</li> <li>• HEO</li> <li>• Lunar</li> <li>• LaGrange</li> <li>• Earth Drift Away</li> <li>• Planetary</li> </ul>	<b>Frequency Bands – Includes Near-Earth and Deep Space Bands, Uplink and Downlink, Command, Telemetry, and Tracking Services</b> <ul style="list-style-type: none"> <li>• S-Band (2 GHz)</li> <li>• X-Band (7, 8 GHz)</li> <li>• Ka-Band (26, 32 GHz)</li> </ul>

DSN services include:

- Command Services
- Telemetry Services
- Tracking Services
- Calibration and Modeling Services
- Standard Interfaces



- Radio Science, Radio Astronomy and Very Long Baseline Interferometry Services
- Radar Science Services
- Service Management

Custom and tailored DSN services can also be arranged for missions and customers. DSN-provided data services are accessed via well-defined, standard data and control interfaces:

- The CCSDS
- The Space Frequency Coordination Group (SFCG)
- The ITU
- The International Organization for Standardization (ISO)
- De facto standards widely applied within industry
- Common interfaces specified by the DSN

The use of data service interface standards enable interoperability with similar services from other providers.

Figure 11.4 shows the DSN antennas and their locations. Each DSN ground station in California (United States), Madrid (Spain), and Canberra (Australia) currently as of 2021 was operating four 34 m Beam Wave Guide antennas and one 70 m antenna. By the late 2020s, this is planned to increase to include one 70 m plus four 34 m antennas at each DSN site.

The DSN supports RF testing using the following facilities:

- Development and Test Facility (DTF-21), located near NASA Jet Propulsion Laboratory (JPL)
- Compatibility Test Trailer (CTT-22), able to come to the spacecraft site

For more information on DSN, please see:

<https://www.nasa.gov/directorates/heo/scan/services/networks/dsn>  
<https://deepspace.jpl.nasa.gov/about/commitments-office/> <https://deepspace.jpl.nasa.gov>

### Swedish Space Corporation

Swedish Space Corporation (SSC) is a global provider of ground station services, including support to launch and early operations, on-orbit Telemetry, Tracking and Control (TT&C) and data downlink, and even lunar services (see <https://sscspace.com/>). The SSC Infinity Network is specifically designed for constellations of small satellites in low-Earth orbits. The global network provides TT&C and data download and delivery services to SmallSat operators, and customer interfaces consist of web-based portals for pass scheduling on 5-meter and smaller antennas. SSC Infinity also uses standard configurations and standardized ground system hardware, limiting the number of mission configurations to help keep costs lower for satellite operators.

Using ground services will generally require some degree of pre-coordination (or “onboarding”) between the operator and provider, which is usually done before launch. This will vary between providers but may include contracting mechanisms; frequency licensing and coordination between the operator and the provider; compatibility testing; and the sharing of mission and vehicle specific information to ensure the ground stations are properly configured for the operator to use. Once the onboarding process is complete, satellite operators can schedule passes between their satellite(s) and desired ground station(s) in advance (the time window varies for each provider). The schedules for each ground station are deconflicted based on scheduling priority, and all frequency and modulation adjustments for the satellite are completed in advance of the pass by the service provider.



Figure 11.4: DSN antennas and their locations. Credit: NASA.

### KSAT<sup>LITE</sup>

Besides the KSAT 9m – 13m antennas, the same corporation operates KSAT<sup>LITE</sup> as a low-cost, high-reliability ground station antenna network designed to support missions operating in low-Earth orbit. Kongsberg Satellite Services AS (KSAT) operates 50+ KSAT<sup>LITE</sup> antennas at 12+ ground station sites across the globe (figure 11.5) and is expanding the network with additional antennas and sites to accommodate the expanding market for missions to low-Earth orbit. KSAT<sup>LITE</sup> is an extension of the existing KSAT ground station antenna network with lower costs, increased flexibility, and improved availability and pass selection. The KSAT network has uniquely located polar stations in the Arctic and Antarctic regions, providing 100% availability on passes for spacecraft in polar orbit. The network also includes mid-latitude ground stations, providing access for diverse orbits and mission profiles. The baseline KSAT<sup>LITE</sup> 3.7-meter antennas provide X-band and S-band for downlink and S-band for uplink. In addition, KSAT<sup>LITE</sup> offers Ka-band downlink and



VHF and UHF capacities to support a variety of system configurations (3). Together with the European Space Agency (ESA) European Space Operations Centre (ESOC), KSAT<sup>LITE</sup> is integrating a network of optical ground stations, and the first station of the Optical Nuclear Network was installed in Greece in January 2021 (4). These stations will support both SmallSats and larger missions that demand a higher throughput or more secure downlink solutions.



Figure 11.5: 2022 KSATLITE ground network map. Credit: KSAT.

#### 11.4.2 Ground Segment as a Service (GSaaS)

Ground Station as a Service (GSaaS) is a managed service which enables customers to communicate, downlink, & process data from their satellites/spacecrafts on as a pay-as-you go basis without needing them to build their own satellite ground stations. These services are usually scalable and use edge cloud services as an intermediate for customers data (5) (6).

##### AWS Ground Station

AWS Ground Station is a managed service (figure 11.6.) that lets customers control satellite communications, process satellite data, and scale satellite operations. Customers can stream satellite data from any of the AWS antennas to the Amazon Elastic Compute Cloud (EC2) for real-time processing or directly store data in the Amazon Simple Storage Service (S3). Additionally, customers can easily integrate their space workloads with other AWS services in near real-time using Amazon's low-latency, high-bandwidth global network. For example, customers who downlink terabytes of data daily can easily access AWS services such as Amazon SageMaker to quickly derive useful information. Other AWS services include Amazon VPC, Amazon Rekognition, and Amazon Kinesis Data Streams. These services allow operators to reduce data processing and analysis times for use cases like weather prediction or natural disaster imagery from hours to minutes or seconds. This also enables operators to quickly create business rules and workflows to organize, structure, and route the satellite data before it can be analyzed and incorporated into key applications such as imaging analysis and weather forecasting (7). A map of the AWS Ground Station antenna regions is shown in figure 11.7.

## How GSaaS works

- Provides global network of ground stations
- On-boarding and Scheduling
- Downlink direct broadcast data
- Allows uplink for command and control
- DB data received by VPC instance
- Data delivered to S3 for processing and distribution

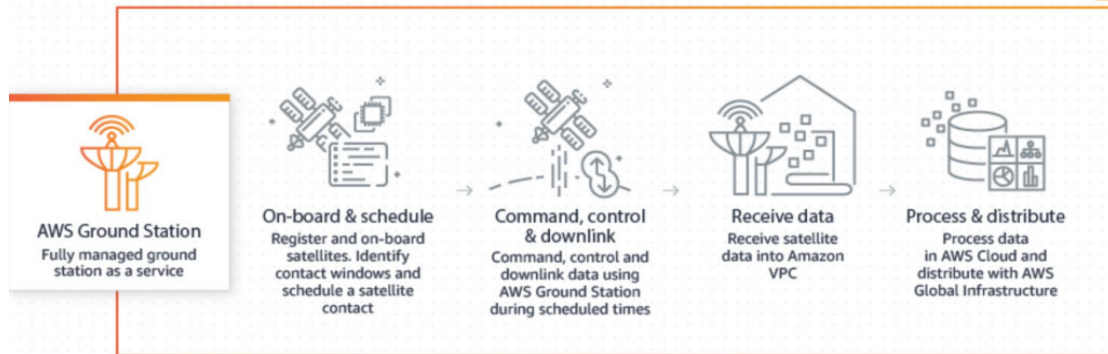
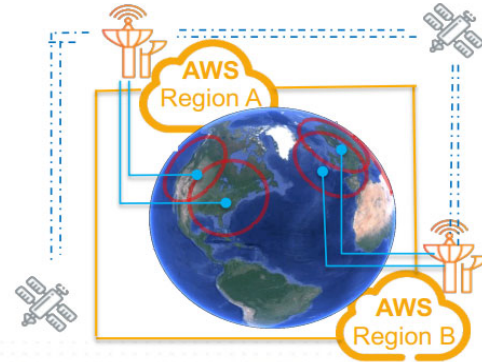


Figure 11.6. GSaaS Flow Chart. Credits: NASA/Amazon Web Services.



Figure 11.7. AWS Ground Station Locations (2021). Credit: Amazon Web Services

AWS Ground Station offers 5.4-meter apertures at each of the antenna regions. AWS Ground Station provides satellite antennas direct access to AWS services for faster, simpler, and more cost-effective storage and processing of downloaded data. Frequencies and link parameters are as follows:

- S-band uplink: 2025-2120 MHz
- S-band downlink: 2200-2300 MHz with G/T of 16 dB/K

- X-band downlink: 7750-8400 MHz with G/T of 30.5 dB/K

AWS Ground Station antennas are interconnected via Amazon’s low-latency, highly reliable, scalable, and secure global network backbone. As of 2022, the AWS Cloud spans 87 Availability Zones within 27 geographic regions around the world, with announced plans for 21 more Availability Zones and 7 more AWS Regions in Australia, Canada, India, Israel, New Zealand, Spain, and Switzerland.

**Scheduling:** AWS Ground Station provides an easy-to-use graphical console that allows operators to reserve contacts and antenna time for their satellite communications. They can review, cancel, and reschedule contact reservations up to 15 minutes prior to scheduled antenna times. Access can be scheduled to AWS Ground Station antennas on a per-minute basis, so operators only pay for the scheduled time. They can access any antenna in the ground station network, and there are no long-term commitments.

### Viasat

Viasat, a leader in ground antenna design, with multiple ground antennas delivered to NASA and industry since the 1960s, has recently become a ground station provider. This move leverages decades of hardware engineering, with an envisioned Real Time Network encompassing “in-house” assets and partner stations, complemented by a satellite relay network philosophy in GEO orbit for low latency (near-real time) applications. A map of Ground Assets is shown in figure 11.8. Viasat operates generous 7.3 m and 5.4 m antennas operating in 3 frequency bands (table 11-7). Future stations are planned in South Africa, Japan, Alaska and Argentina (8).

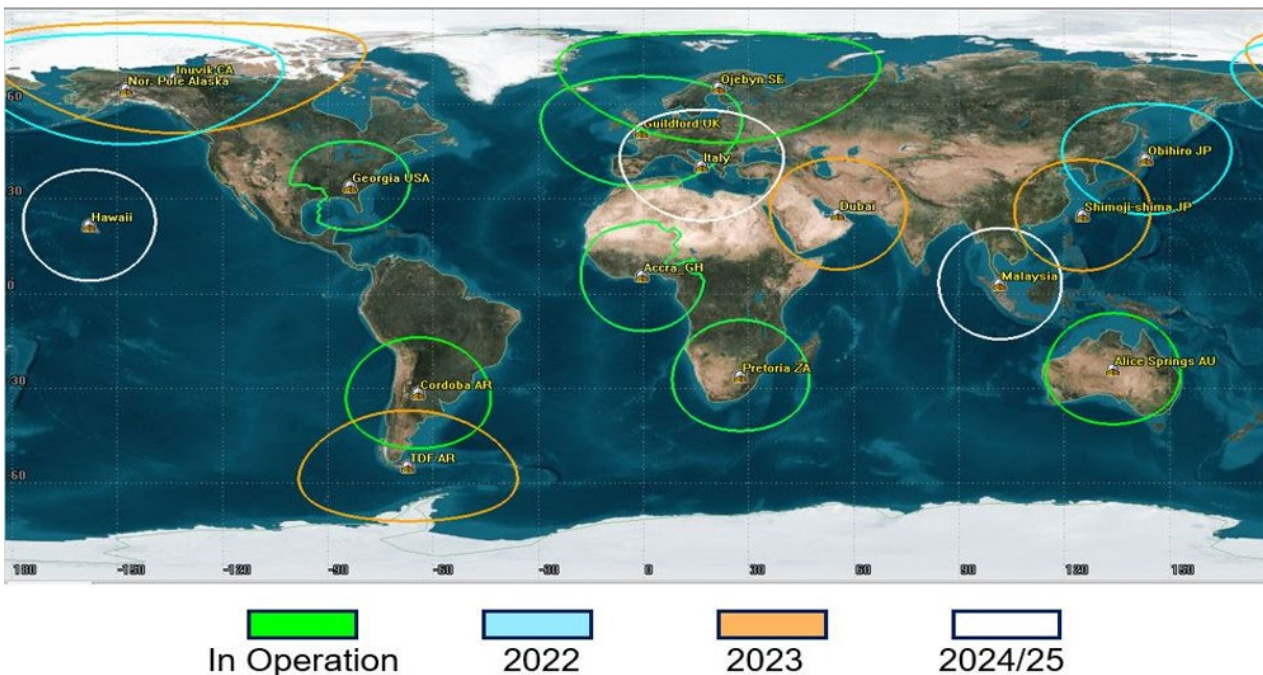


Figure 11.8: Viasat RTE Global Ground Stations. Credit: Viasat.

**Table 11-7: Viasat RTE Global Ground Stations and Parameters**

Site Location	Antenna	S-band Uplink	S-band Downlink	X-band Downlink	Ka-band Downlink
Pendergrass, GA	5.4 m X-Y Full motion 5 °/sec max speed	2025-2110 MHz EIRP: 53.2 dBW Selectable RHCP or LHCP	2200-2290 MHz G/T: 17 dB/K Selectable RHCP or LHCP	8025-8400 MHz G/T: 30 dB/K Simultaneous RHCP and LHCP	N/A
Guildford, UK	5.4 m X-Y Full motion 5 °/sec max speed	2025-2110 MHz EIRP: 53.2 dBW Selectable RHCP or LHCP	2200-2290 MHz G/T: 17 dB/K Selectable RHCP or LHCP	8025-8400 MHz G/T: 30 dB/K Simultaneous RHCP and LHCP	N/A
Alice Springs, AU*	7.3 m X-Y Full motion 6 °/sec max speed quantity 2	2025-2110 MHz EIRP: 65.0 dBW Selectable RHCP or LHCP	2200-2290 MHz G/T: 18 dB/K Selectable RHCP or LHCP	8025-8400 MHz G/T: 32 dB/K Simultaneous RHCP and LHCP	25500-27000 MHz G/T: 34.5 dB/K Simultaneous RHCP and LHCP
Ghana*	7.3 m X-Y Full motion 6 °/sec max speed	2025-2110 MHz EIRP: 65.0 dBW Selectable RHCP or LHCP	2200-2290 MHz G/T: 18 dB/K Selectable RHCP or LHCP	8025-8400 MHz G/T: 32 dB/K Simultaneous RHCP and LHCP	25500-27000 MHz G/T: 34.5 dB/K Simultaneous RHCP and LHCP
Cordoba, AR	5.4 m X-Y Full motion 5 °/sec max speed	2025-2110 MHz EIRP: 53.2 dBW Selectable RHCP or LHCP	2200-2290 MHz G/T: 17 dB/K Selectable RHCP or LHCP	8025-8400 MHz G/T: 30 dB/K Simultaneous RHCP and LHCP	N/A
Öjebyn, Sweden	7.3 m X-Y Full motion 6 °/sec max speed	2025-2110 MHz EIRP: 55.2 dBW Selectable RHCP or LHCP	2200-2290 MHz G/T: 18 dB/K Selectable RHCP or LHCP	8025-8400 MHz G/T: 32 dB/K Simultaneous RHCP and LHCP	25500-27000 MHz G/T: 34.5 dB/K Simultaneous RHCP and LHCP



Pretoria, South Africa (PRY)	7.3 m X-Y Full motion 6 °/sec max speed	2025-2110 MHz EIRP: 55.2 dBW Selectable RHCP or LHCP	2200-2290 MHz G/T: 18 dB/K Simultaneous RHCP and LHCP	8025-8400 MHz G/T: 32 dB/K Simultaneous RHCP and LHCP	25500-27000 MHz G/T: 34.5 dB/K Simultaneous RHCP and LHCP
Obihiro, Japan (OBO)	7.3 m X-Y Full motion 6 °/sec max speed	2025-2110 MHz EIRP: 55.2 dBW Selectable RHCP or LHCP	2200-2290 MHz G/T: 18 dB/K Simultaneous RHCP and LHCP	8025-8400 MHz G/T: 32 dB/K Simultaneous RHCP and LHCP	25500-27000 MHz G/T: 34.5 dB/K Simultaneous RHCP and LHCP
Shimoji- shima, Japan (SHI)	7.3 m X-Y Full motion 6 °/sec max speed	2025-2110 MHz EIRP: 55.2 dBW Selectable RHCP or LHCP	2200-2290 MHz G/T: 18 dB/K Simultaneous RHCP and LHCP	8025-8400 MHz G/T: 32 dB/K Simultaneous RHCP and LHCP	25500-27000 MHz G/T: 34.5 dB/K Simultaneous RHCP and LHCP
North Pole Alaska USA 7.3 m (NTP01)	7.3 m El-Az- Train El & Az: 15 °/s max speed Train 6 °/s max	2025 – 2120 MHz EIRP: 53 dBW Selectable RHCP or LHCP	2200–2300 MHz G/T: 19 dB/K Simultaneous RHCP and LHCP	8000–8500 MHz G/T: 32 dB/K Simultaneous RHCP or LHCP	N/A
North Pole Alaska USA (9.1 m (NTP02)	9.1 m El-Az- Train	2042–2052 MHz EIRP 38 dBW Selectable RHCP or LHCP	N/A	8000–8500 MHz G/T: 34 dB/K RHCP	N/A
Canada (YEV)	7.3 m X-Y Full motion 6 °/sec max speed	2025-2110 MHz EIRP: 55.2 dBW Selectable RHCP or LHCP	2200-2290 MHz G/T: 18 dB/K Simultaneous RHCP and LHCP	8025-8400 MHz G/T: 32 dB/K Simultaneous RHCP and LHCP	25500-27000 MHz G/T: 34.5 dB/K Simultaneous RHCP and LHCP

\*Additional L-band uplink 1755-1850 MHz. EIRP: 63.4 dBW

Viasat's Real-Time Earth (RTE) ground segment service enables communications for next-generation and legacy LEO satellites using S, X, and Ka-bands. RTE offers downlinks from low megabits per second to multiple gigabits per second empowered by cutting edge software-defined radios. The service includes high-speed connectivity for backhaul, real-time data streaming, and real-time monitoring of passes.

Viasat's fully automated system allows users their choice of machine-to-machine or manual GUI-based scheduling over a highly resilient cloud-based platform. Instantaneous confirmation of your



pass without human intervention lowers your cost and risk of human error. Data is delivered to your choice of cloud provider, operations center, or government cloud destination.

Viasat's Real-Time Earth Space Relay is designed to leverage the ViaSat-3 global constellation with a newly developed terminal that will enable on-demand and cost-effective communications for LEO spacecraft anywhere and at any time in their global orbit. Viasat won a portion of the NASA Communications Service Provider contract with its integrated RTE ground solution, which will include on-orbit demonstrations in 2025 that allow users to select between the low latency space relay and the high throughput global ground network (8).

## SpaceLink

Vendors like SpaceLink are responding to the fact that NASA is actively moving towards procuring commercially provisioned communications services for its near-Earth missions. The private sector is to provide direct-to-earth (DTE) communications by 2023 and Lunar Space Relay (LSR) navigation and communication services by the mid-2020s.

SpaceLink is creating a TDRSS-like capability to significantly increase throughput, provide persistent links to space-borne assets, and securely deliver data near real-time (figure 11.9). Increased human spaceflight missions and proliferated LEO constellations have created ground station bottlenecks and a conflicted Radio Frequency (RF) spectrum for many satellite operators. At the same time, market demand marches inexorably toward immediate data delivery. Expansion and commercialization of Lunar activities will only compound the problem for RF-based space and ground communications.

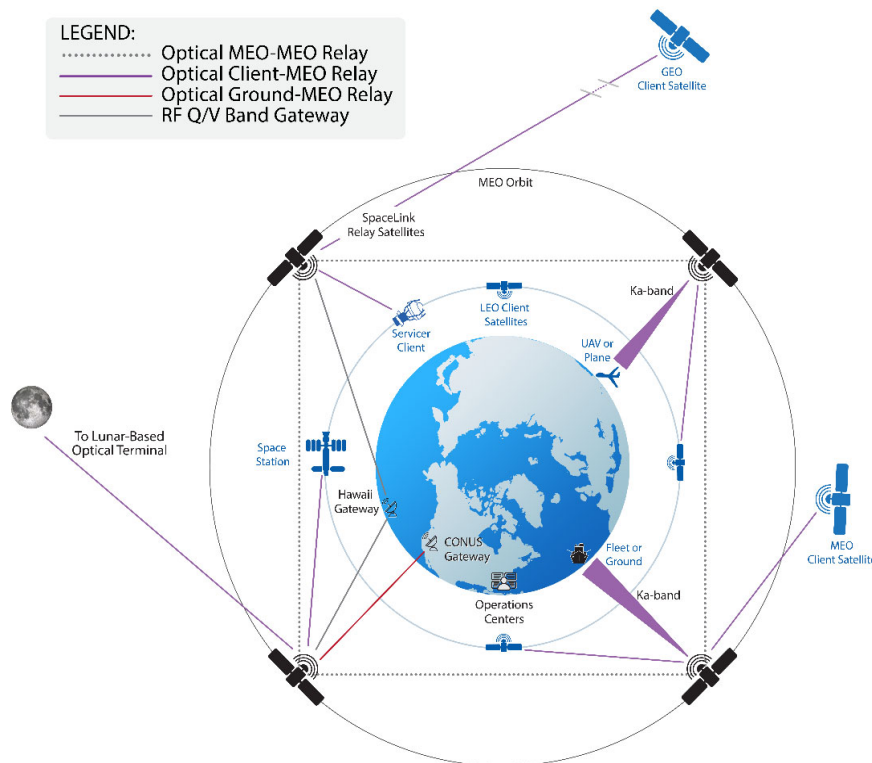


Figure 11.9. SpaceLink Architecture (Block 0). Credit: SpaceLink.

SpaceLink is deploying a hybrid approach to address these challenges with its optical and RF-based space and ground network. Launching in 2024, SpaceLink's network of four Medium Earth Orbit (MEO) satellites and ground stations will provide a commercial relay service for continuous optical and Ka-band connectivity to near-Earth spacecraft, space stations, and platforms.



SpaceLink's hybrid RF/optical approach to its space and ground segments is commercially unique, offering our customers secure, high-throughput, and high-availability services for their communication needs in near-Earth orbit. SpaceLink is compatible with the Space Development Agency's (SDA) optical communications standard. Both downlink and uplink can be supported with a single user terminal and offers simultaneous relay transmission through our system. Satellite TT&C are also accommodated in near real-time, leveraging the large uplink/downlink bandwidth. Our RF/optical technologies and relay network are elastic and can scale with increasing users and bandwidth demands. The SpaceLink roadmap extends to the Lunar regions supporting future NASA/Artemis and commercially fielded missions (see <https://www.eosspacelink.com/>).

### Leaf Space

Leaf Space is a Ground-Segment-as-a-Service provider, operating a globally distributed ground stations network tailored to support SmallSats in low-Earth orbit. Founded in 2014, Leaf Space has experience supporting a vast array of different satellite missions, applications and data needs - from orbital transfer vehicles to synthetic-aperture radar.

Called *Leaf Line*, Leaf Space's network enables TT&C and payload data transmissions to and from the satellite operators' mission control software and cloud platform of choice, see figure 11.10. It does so via a simple interface, a proprietary autonomous scheduling software, and global coverage ideal for both mid and high-inclination orbits. Leaf Line antennas are either fully owned or managed on an exclusive basis, ensuring maximum availability, flexibility, and independence of operations. Leaf Line is powered and orchestrated by a cloud architecture, and is designed to support multiple satellite missions and operators at the same time. The network's architecture allows seamless use of any of the antennas with a single integration procedure and no difference in operations or performances. Through Leaf Line, Leaf Space works with its customers to execute both routine operations and complex tasks such as LEOP or MSPA data downlink for formation flying satellite clusters.

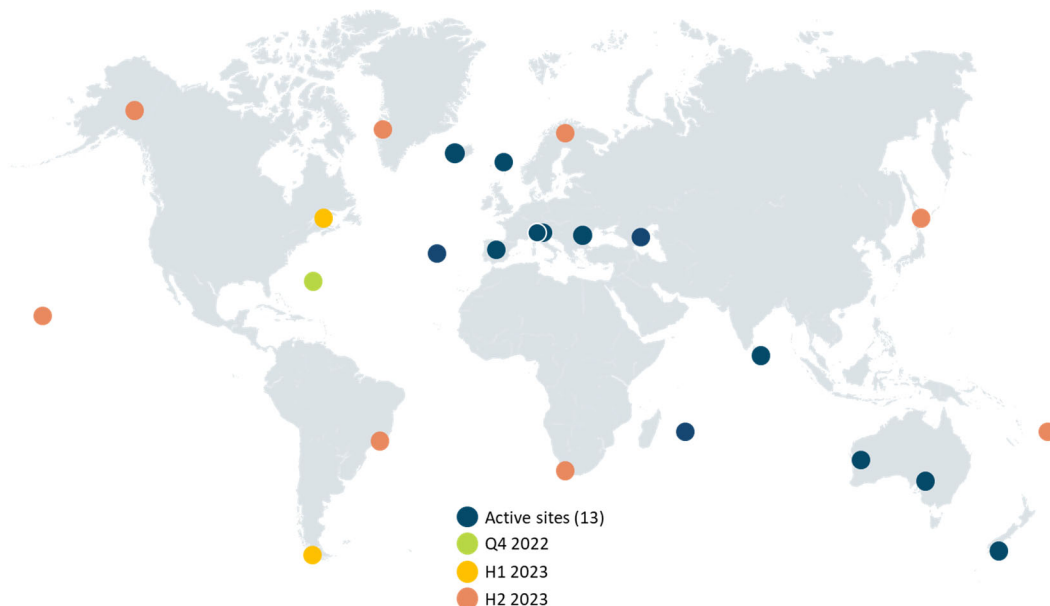


Figure 11.10: The Leaf Line network, October 2022. Credit: Leaf Space.

Leaf Line is characterized by ~3.7m antennas supporting operations in S-band uplink (2025-2110 MHz, EIRP: 50 dBW) and downlink (2200-2290 MHz, G/T: 12.8 dB/K) and X-band downlink (8025-8400 MHz, G/T: 25.4 dB/K), as well as by UHF antennas (uplink and downlink). In 2023,



the Leaf Line network will be upgraded to support Ka-band downlink (25.5-27 GHz) at selected sites, whilst it will keep expanding in terms of sites, capacity, and antenna performances. With an eye towards the future of the sector, Leaf Space is working to integrate optical ground systems as well as cislunar-oriented solutions to its existing network.

In addition to providing access to the Leaf Line network, Leaf Space can procure, deploy and operate dedicated ground stations (service offering called *Leaf Key*), enabling operators with particular frequencies, access or data requirements to leverage Leaf Space's cloud architecture and ground segment experience without compromising on antenna time. For more information on the company or on how Leaf Space can support current and future missions, please contact [sales@leaf.space](mailto:sales@leaf.space) or visit <https://leaf.space>.

### **Laser Light**

Laser Light Communications operates a Global Network platform, delivering a first-of-a-kind 21st century data service that will transform the way high volume communications traffic is carried. Using a hybrid infrastructure spanning terrestrial, subsea, and space domains; an end-to-end software defined architecture offering all-optical: up to 400 Gbps connectivity and provisioning within minutes (see <https://www.laserlightcomms.com/>).

#### Network On Demand

- Pay-as-you-go: only pay for the duration you use the service with no upfront or fixed costs
- Cost Effective: automation and end-to-end control yields significant operating cost savings
- Secure: highly targeted, dynamic, laser links are extremely difficult to intercept and can be encrypted
- High Capacity/ Performance: data delivery at up to 400 Gbps in the most direct route from origination to destination, automatically bypassing points of congestion

#### Data Transport as a Service

- Pay-as-you-go: only pay for volume you use when you use it with no upfront or fixed costs
- Cost Effective: automation and end-to-end control yield significant operating costs savings
- Secure: highly targeted, dynamic, laser links are extremely difficult to intercept and can be encrypted
- High Capacity/Performance: data delivery at optical speeds -- up to 400 Gbps directly from the point of origination to the point of destination, automatically bypassing points of congestion along the way

### **11.4.3 Space Relay Network - NASA**

Unlike a traditional ground network that goes direct from a "client" satellite to a ground station on the ground, space relay networks consist of communication satellites that relay data from the "client" satellite down to a ground station. While some no longer consider it state-of-the-art, NASA's Tracking and Data Relay Satellite System (TDRSS), shown in figure 11.11, is one of the most well-known space relay networks. TDRSS relays data from the International Space Station (ISS) and the Hubble Space Telescope to NASA ground stations around the world.

Space relay networks can be beneficial for small satellites in low-Earth orbit because those SmallSats are only in view of a ground station for a portion of their orbit. However, depending on the orbit of the relay satellites, a low-Earth orbit SmallSat could be in view of a relay satellite for

most of its orbit. This makes a relay network beneficial for a SmallSat, especially right after SmallSat deployment when a ground station is still trying to locate the satellite. The space relay can transmit satellite telemetry, tracking, and control data to the ground, enabling faster satellite identification. This proves to be even more valuable when the satellite is deployed with several others for a given rideshare opportunity. This data can also contain satellite health information to give mission teams either peace of mind while awaiting acquisition by the ground station, or information for troubleshooting prior to the commissioning phase. Another benefit is the ability to



Figure 11.11: NASA's Tracking and Data Relay Satellite System. Credit: NASA.

obtain real-time event notifications without the need for prior scheduling. Scientists are interested in using this technology to alert the science community when certain phenomenon are observed. Space relay networks often require special hardware or software that must be added to a satellite before launch. In general, a satellite operator will purchase a modem compatible with the relay network and fly it on their satellite to access the network. It is common for the network providers to license their proprietary chipset to developers who build the modem hardware and serve as a service broker. Because of this added hardware component, the decision to leverage a space relay network must be made before the satellite has been launched.

#### 11.4.4 Low Latency, Low rate (Short burst) Space Relay Providers

Space relay solutions are less common than traditional direct-to-Earth solutions, but there are a few options that exist for small satellites, see table 11-8. To access the space relay, a satellite operator purchases a modem from the relay manufacturer and flies that on their satellite to access the relay services. In general, space relays are ideal for obtaining satellite TT&C data (health and safety of the vehicle) rather than for large data downlinks.



<b>Product</b>	<b>Manufacturer</b>	<b>TRL</b>	<b>Specifications</b>
Iridium Global Network	Iridium	9	LEO relay requiring 9600 series transceivers onboard the satellite
Fast Pixel Network	Analytical Space	6	Establish a data transport network in LEO

**The Iridium network** is one example satellite customers can rely on for delivering low latency messages. Iridium uses a combination of Frequency Division Multiple Access (FDMA) and Time-Division Multiple Access (TDMA) for its communication waveforms. L-band (1616 – 1626.5 Mhz) is used for uplink and downlink between the user spacecraft and the Iridium spacecraft. Inter-satellite communication links between Iridium satellites is accomplished through Ka-band (23.18 – 23.28 GHz). Operators install an Iridium transceiver (9600 series) onboard their spacecraft to communicate with the Iridium network. Messages are relayed through Iridium’s Short Burst Data Service, which is hosted on Iridium’s cloud platform for easy user operation. For each transceiver unit, a data plan must be chosen and purchased, much like cellular phone data plans, and the plan details are linked to the unit’s ID, which is referred to as International Mobile Equipment Identity (IMEI). The special feature of this system is that it has as an option for “IMEI-to-IMEI” transmission. When an Iridium IMEI is activated, five output destinations may be specified. Most vendors allow for a combination of emails addresses, fixed IP address, or another device with an IMEI ID (6).

Iridium has announced the commercial availability of its Certus 100 ‘midband’ service providing 88 kbps connectivity via small antennas and battery-powered devices, for basic data communications and IoT applications (9).

**Analytical Space** is another company to watch for future services. Their recent contract puts a LEO relay in space to aggregate data from GEO satellites. Through Fast Pixel Network, Analytical Space Inc. plans to establish a data transport network in low-Earth orbit to ingest data from geospatial intelligence satellites, send the data from node to node via high speed optical intersatellite links, and deliver the data to military, intelligence and commercial customers (10 High speed MEO and GEO commercial relays are not presently operating, but several are planned. These are listed under the State-of-the-Art Ground Data and Supporting Systems section (11.9).

## **11.5 Ground Stations Components**

The hardware for ground stations consists of the tracking antenna, its feed, and the modem that converts the RF waveform into digital packets and vice versa.

### **11.5.1 Ground Station Operation**

A DTE ground station is comprised of a system of hardware and software working together to convert the RF signal from a satellite signal into digital data. The first key element of the system is the antenna. It is chosen based on the frequency and gain required to talk with a satellite. NASA uses parabolic reflector antennas for RF ground satellite communications, while some universities use dish or Yagi antennas.

The dish antenna uses a parabolic reflector to collect signals from the spacecraft and focus them onto a feed antenna. The feed antenna is typically a horn antenna with a circular aperture. The size of a dish is at least several wavelengths in diameter at the frequency of operation and can be increased for higher gains. The distance between the feed antenna and parabolic reflector can also be several wavelengths. For example, a Ka-band 34 m deep space antenna with a feed distance of 15 m would be approximately 3,000 wavelengths for the dish diameter and 1,500 wavelengths for the feed distance relative to a 1 cm Ka-band wavelength. The gain of a dish reflector (figure 11.12) is frequency-dependent and it is directly related to the square of its diameter. Dish antennas are available in sizes from 1 meter to 70 meters in diameter.



*Figure 11.12: Ground Antenna in Fairbanks, Alaska. Credit: NASA/ Clare Skelly.*

The antenna collects RF waves and the antenna feed converts the electromagnetic waves into conducted RF electrical signals. The feed consists of a resonant pickup that is tuned to the transmit or receive frequency, a low gain low-noise amplifier, a sharp filter, and a second low noise amplifier with more gain than the first amplifier. These elements condition the signal. The signal then traverses through a coaxial cable to a nearby location where a radio demodulates the RF signal into digital data. In the uplink direction, the radio modulates the data bits onto an RF carrier which is amplified to 10 or more watts. The amplified RF resonates in the antenna feed, and the antenna amplifies the electromagnetic waves and focuses them towards the satellite.

It is desirable to have significant antenna gain, but as the gain increases, the beamwidth of the antenna decreases. There is a practical compromise where the beamwidth is so small that tracking is difficult and when the antenna gets so large that it is difficult to procure or manage. A typical antenna pattern is shown in figure 11.13. There is a center lobe where most of the transmitted energy is contained. The remaining energy is stored in the sidelobes on either side of the main lobe. The diminished side lobes are intentional so that ground noise from other emitters on Earth are not collected when receiving and so that interference to terrestrial systems is not created when transmitting. The blue arrows in the figure indicate the full-width-half-max gain point at about  $\pm 6^\circ$ , which should result in an antenna pointing error of less than  $6^\circ$  and the full-width-half-max gain of 16 dBi to be used in a link budget. If more gain is needed, then the antenna will increase in size and the beamwidth will correspondingly decrease.

Directional antennas point towards the satellite as it moves over the ground station. Pointing adjustments are necessary in both the vertical (elevation) and horizontal (azimuth) directions. These movements are accomplished using motors and gears. Tracking software is used to predict the satellite's future location. The satellite position and time are processed through additional software that converts this information into commands for the motor controller. Time is an important factor and GPS time is used by the computer generating the satellite position estimate. A dedicated GPS receiver is connected to the computer for that purpose.

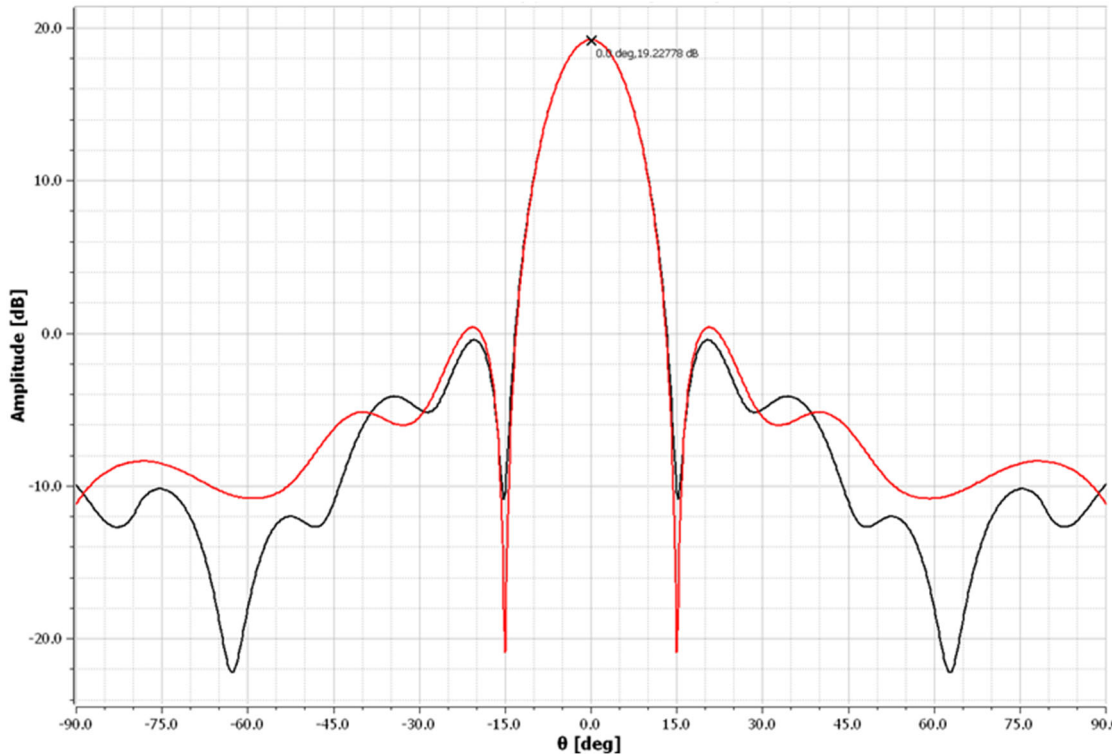


Figure 11.13: Antenna pattern from a 1.8-meter diameter parabolic dish operating at 915 Mhz with a high gain center lobe and diminished side lobes. Credit: NASA.

The cost of a DTE ground station is directly correlated with the size of the aperture, which drives the ground station foundation, pedestal, motors, and gears. The Yagi is less expensive. It sustains low wind loads and therefore can use a smaller foundation for support. In contrast, the dish antenna reflector sustains comparatively high wind loading and therefore needs a stronger concrete foundation and larger motors and gear box elements than the Yagi antenna.

**11.5.2 Component Hardware for Ground Systems (GS)**

This section lists examples of GS components and some supporting equipment. Table 11-9 lists example products in each category. The antenna feed consists of the RF pickup, LNA and mechanical filters located directly on the antenna. A radome is an RF transparent enclosure that protects the antenna from weather.

Table 11-9: Ground System Components		
Product	Manufacturer	Type of Product
Tracking Antenna	Viasat, Safran	Antennas for small satellites in and S, X and Ka-band frequencies
Antenna Feed	See End-to-End Hardware Section 11.7.2	RF pickup, mechanical filters, low noise amplifier



Radio, Software Defined	NI Ettus Research	USRP X410, up to 7.2 GHz with RFSOC advanced FPGA and meeting wide bandwidth requirements. USRP X310: DC-6 GHz with up to 160 MHz of baseband bandwidth, multiple high-speed interfaces
Data Receiver	Safran Data Systems	Cortex CRT (low data rate) and HDR (high data rate (previously by Zodiac)
Modem, for TT&C and Payload Reception	Safran Data Systems	Satcore, plug-and-play modem for TT&C and Payload Reception
Digital Processing	Kratos	SpectraNet: Digital IF product that converts analog signals at RF frequencies up to S-band into digital IF packets.
Radome	Infinite Technologies	Antenna radomes
Ground Station Dongle	GAUSS	A USB low-power board to simulate ground station in laboratory conditions. The USB dongle integrates both a low-power UHF transceiver and a TNC, thus miniaturizing common ground station rack systems
Integrated Testing Systems (EGSE) & Ground Station TT&C Modems	Celestia Satellite Test & Simulation	Hardware and software elements all operating within a single reference platform and environment

### Cortex HDR

Several NSN, SSC and NOAA stations use the Cortex HDR High Data Rate Receiver, which performs demodulation, decoding and frame synchronization on the (X-band) data stream. Each virtual channel in the AOS frame that is received by the station X-band receiving system will be written into separate files. Files are separated into small one-minute file sizes for a single VCID that allow for faster turn-around time on the data and smaller transmission cycles in case of transfer problems. File-based data is stored in a buffer (e.g., for 7 days) used for retransmissions and failure recovery when necessary. At the end of a pass, ground stations such as the NSN ones, perform an automatic secure file transfer protocol (SFTP)/secure copy protocol (SCP) push to the customer. If the customer wants to “replay” a data set they may use the self-service /SFTP/SCP interface on the system to pull their data to their site. Alternatively, the customer may choose to manually retrieve files and not select automatic file transfer (11).

### USRP X310 and X410 Open-Source Software Defined Radio for SatCom Applications

The NI Ettus Research brand includes the Universal Software Radio Peripheral (USRP™) family of products. The USRP is one of the most popular open platforms for small satellite communications with options from high-performance to low-cost to highly deployable. One of the most popular hardware units for satellite communication applications is the USRP X310 with the UBX RF daughterboard. The USRP X310 is a high-performance software defined radio with the ability to transmit and receive modulated signals. With up to 160 MHz of instantaneous bandwidth and a frequency tuning range up to 6 GHz, the X310 with UBX has the raw hardware performance to cover many ground station satellite communication needs. The USRP family supports a wide range of software tool chains from LabVIEW to GNU Radio, with many existing IP modules for





modulation and demodulation. The USRP X310 is intended for lab environments, however, it can be built in rugged weatherproof configurations. Many small satellite researchers are using the USRP as their ground station equipment for its adaptability with open-source software and its embedded FPGA pre-processing capability. The USRP X310 offers 2 channels, 10 GIGE and PCIE bus, whereas the NI Ettus USRP X410 is equipped with two dual 100 GbE interfaces capable of moving much more data (12).

### **Kratos SpectralNet**

SpectralNet eliminates the distance constraints of RF transport by digitizing RF signals for transport over IP networks in a way that preserves both frequency and timing characteristics, and then uniquely restores the RF signals at their destination. By eliminating the distance constraints between antennas and signal processing equipment, this technology enables operators to deploy new ground architectures with numerous advantages, such as the ability to mitigate the effects of rain fade for Ku/Ka satellites, reduce costs by centralizing operations, simplify disaster recovery and system maintenance, optimize antenna placement, and develop a migration path toward virtual ground systems. SpectralNet does all of this while protecting the operator's current investment in existing equipment (13).

### **Integrated Testing Systems & Ground Station TT&C Modems**

Celestia Satellite Test & Simulation BV (C-STS) provides ground-based solutions in the domains of satellite simulation, testing, communication, and data processing. Established in 1985, Satellite Services B.V. (SSBV) was acquired by Celestia Technologies Group in 2016 and re-branded to Celestia Satellite Test & Simulation B.V. to continue as a competence center for Electrical Ground Support Equipment (EGSE) and TT&C solutions. Celestia STS has more than 30 years of experience in the space industry. More than 300 EGSEs and TT&C modems were delivered to space agencies, large system integrators, and specialized flight-equipment manufacturers around the world.

On-board computers, mass memory units, and transponders are tested every day with C-STS equipment. Celestia EGSE solutions have been used in more than 80% of all European Space Agency (ESA) missions. Celestia STS testing equipment is available in standard functionality or configured to meet specific customer needs. System options include:

- Telemetry and Telecommand Processing System
  - TM acquisition and simulation
  - TC generation and acquisition
  - Bit error rate tester
  - TC authentication
  - TM/TC deciphering (API/DLL/LAN)
  - Includes control and monitor software for data processing and visualization
- Wizardlink High-Rate Interface System
  - Up to 4 Wizardlink channels in parallel
  - Up to 2Gbps data rate perchannel
  - Includes software for high speed ingest, processing, data archiving, and export
- LVDS High-Rate Interface System
  - Up to 4 parallel LVDS inputs and outputs
  - 8-bit parallel up to 1Gbps perchannel
  - Teaming of 2 LVDS input and output channels to 16-bits



- 16-bit parallel up to 2Gbps per channel
- Includes software for high speed ingest, processing, data archiving, and export
- TT&C Integrated Modem and Baseband unit
  - Single or dual channel modulation and demodulation
  - Ranging measurement
  - Doppler simulation
  - Bit error rate tester
- Level Zero Processor Software for High-Speed Data Processing
  - Data directly from the local disk drive or shared network drive
  - Processing of TM data from bitstream to frame and packet level
  - Configurable frame and packet checking rules
  - Configurable frame and packet output data storage and sorting
  - Live frame and/or packet distribution via LAN
  - Real-time statistical analysis, error checking, and reporting
- Optical Digital Convertor
  - Processing of optical detector signals to simulate optical communications

Efforts are on-going to improve product capability with a focus on modular, flexible, scalable multichannel systems that take advantage of the latest technologies. In June 2021, an agreement between the Netherlands Organization (TNO), Celestia, and the Netherlands Organization for Applied Scientific Research to commercialize optical modems (14).

### **Infinite Technologies Radomes**

A successfully designed radome provides a protective cover and has minimal effect on the electrical functionality of the antenna. Figure 11.14 provides an example of a radome supplied by Infinite Technologies. Radomes provide the antenna system with a controlled environment, shielding sensitive equipment from weather related stresses such as wind, snow, ice, salt spray, etc. A radome can increase the useful life of the antenna and decrease overall maintenance costs for the system. Consideration for a radome should be given early in the design phase of the system, as a radome will allow for lighter duty and less expensive components such as drive motors and foundations due to the elimination of wind loads on the antenna. Also, the controlled environment inside the radome provides greater system availability allowing the antenna to operate in more adverse environmental conditions with minimal signal degradation. A radome will also provide maintenance personnel protection from weather during antenna maintenance (15).

For a radome to be a benefit, the unique attributes of the system being protected must be taken into consideration. A well-designed radome addresses these factors and can avoid negatively affecting the performance of the antenna system. Careful selection of a radome can improve overall system performance and readiness by:

- Allowing operation in severe weather by protecting the antenna from wind, rain, snow, hail, sand, salt spray, insects, animals, UV damage, windblown debris, and wide temperature fluctuations
- Providing security for the antenna system and protecting it from observation, vandalism etc.
- Providing a controlled environment which minimizes downtime, extends component and system operating life

- Permitting the use of more economical antenna pedestals, foundations, and drive system components



Figure 11.14: Infinite Technologies small radome. Credit: Infinite Technologies

### 11.5.3 Ground Software

Ground Station Software include visualizing and calculating the satellite location in orbit and controlling the tracking antenna. Command and control software manages command scripts to be sent to the satellite and can display and analyze telemetry. Many software options are open source and free. Other software may be purchased from companies with a long history in ground segment solutions who had previously provided hardware products to do these tasks (table 11-10).

Table 11-10: Software for Ground Systems			
Product	Manufacturer	TRL	Type of Product
softFEP	AMERGINT	9	Emulation ground systems software
quantumFEP	Kratos	9	Software that performs data formatting and interface conversion for commands and telemetry, with full support for NSA Type 1 and AES encryption/decryption devices
Gpredict	Alexandru Csete	9	Open-source software that tracks satellites and provides orbit prediction in real-time. Radio and antenna rotator control for autonomous tracking



GNU Radio	GNU Project	9	Free software development toolkit that provides signal processing blocks to implement software-defined radios and signal processing systems
HWCNTRL	DeWitt & Associates	9	Ground station control program with an automation software package

### **AMERGINT softFEP**

AMERGINT softFEP applications are deployed virtually on cloud architectures or hosted on dedicated servers. The applications perform control center data formatting and interface conversion for commands and telemetry, with full support for NSA Type 1 and AES encryption/decryption devices. SoftFEP applications are built on a proven library of more than 1,000 software devices. This allows each softFEP application to be tailored to the requirements specific to the ground system. Processing chains configured via Python scripts move satellite downlink data from Earth receipt for processing and uplink data to the radiating site. Deploying softFEP on multiple virtual machines (VMs) or within the cloud is inherent in the product architecture. Virtualized softFEP deployments support a wide range of ground system architectures while taking advantage of cloud-computing benefits. When applications are deployed in VMs, they can be hosted locally or run remotely in a cloud and interoperate across network connections. Customers have deployed their softFEP applications as independent network gateways, black front-end processors, red front-end processors, and data recorders, flowing data between the VMs as a satellite contact is processed (16).

### **Kratos quantumFEP**

The quantumFEP satellite front-end software provides the digital processing and network connectivity needed between the Command & Control (C2) system and the RF signal processing equipment. All the digital processing functions in a typical small satellite ground system are included: command and telemetry processing, recording, AES COMSEC security, CSSDS processing, packet level FEC, and network gateway interface support. Monitoring and control can be done using the HTML5 user interface or using REST or application programming interface GEMS APIs. Figure 11.15 provides an illustration for quantumFEP system architecture (17).

Key features of quantumFEP are:

- Can be used on machines, a private cloud, or with cloud provider
- Suitable for all types of SmallSat programs – SmallSats, CubeSats, NanoSats, and MicroSats
- Compatibility tested with widely used groundmodems
- Built-in test functions reduce Integration and Test (I&T) effort – ultimately reducing cost
- Configurable as mission requirements change or as new missions come online
- Commercial AES Encryption/Decryption standard feature with built in AES Key Manager
- Standard TCP/IP, GEMS, REST and VITA-49 interfaces make integration a snap
- Pure Software Implementation for signal processing functions
- Access and control from anywhere through the web with no client software to install or maintain

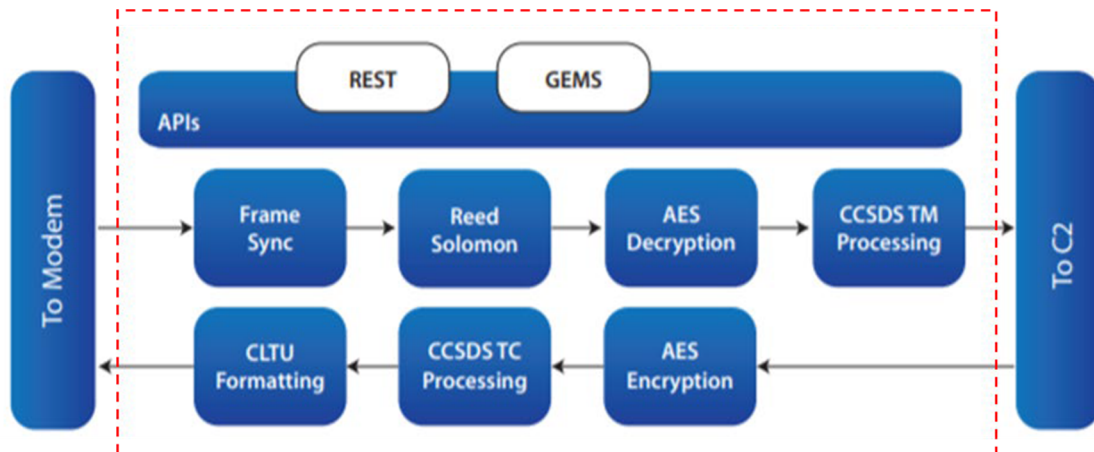


Figure 11.15: Kratos quantumFEP system architecture. Credit: Kratos.

## Gpredict

Gpredict is a real-time satellite tracking and orbit prediction application. It can track a large number of satellites and display their position and other data in lists, tables, maps, and polar plots (radar view) as shown in figure 11.16. It can also predict the time of future passes for a satellite and provide detailed information about each pass. Gpredict is different from other satellite tracking programs in that it allows the satellites to be grouped into visualization modules. Each of these modules can be configured independently from others, allowing unlimited flexibility in the look and feel of the modules. It will also allow satellite tracking relative to different observer locations at the same time (18).

The following are key features of the software:

- Fast and accurate real-time satellite tracking using the NORAD SGP4/SDP4 algorithms
- No software limit on the number of satellites or ground stations
- Appealing visual presentation of the satellite data using maps, tables and polar plots (radar views)
- Allows satellites to be grouped into modules, each module having its own visual layout, and being customizable on its own. Of course, several modules can be used at the same time
- Radio and antenna rotator control for autonomous tracking
- Efficient and detailed predictions of future satellite passes. Prediction parameters and conditions can be fine-tuned by the user to allow both general and very specialized predictions
- Context sensitive pop-up menus allow future passes to be quickly predicted by clicking on any satellite
- Exhaustive configuration options allowing advanced users to customize both the functionality and look & feel of the program
- Automatic updates of the Keplerian Elements from the web via HTTP, FTP, or from local files
- With a robust design and multi-platform implementation, Gpredict can be integrated into modern computer desktop environments, including Linux, BSD, Windows, and

## Mac OS X

- As free software licensed under the terms and conditions of the GNU General Public License, it can be freely used, learned from, modified, and re-distributed

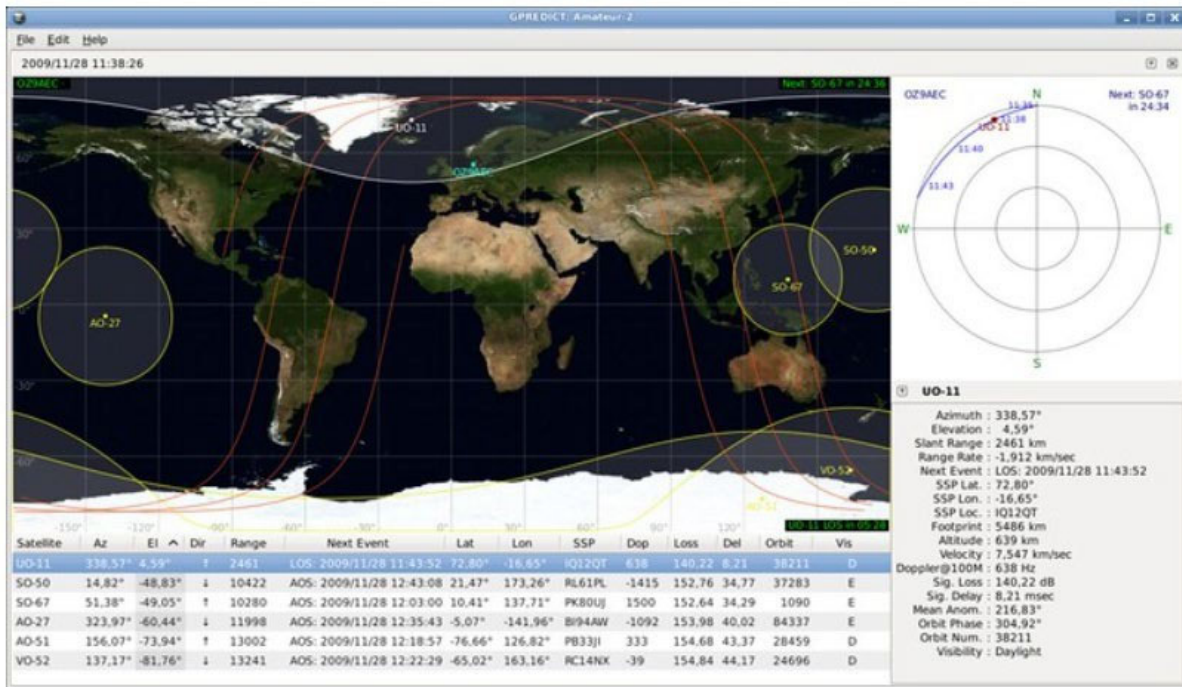


Figure 11.16: Gpredict graphical display with multiple satellites. Credit: Gpredict.

## GNU Radio

GNU Radio is a free & open-source software development toolkit for developing radio systems in software as opposed to completely in hardware. It can be used with readily available low-cost external RF hardware and runs on most modern computers to create software-defined radios. It can also be used without hardware in a simulation-like environment.

GNU Radio performs all the signal processing. It can be used to write applications to receive data out of digital streams or to push data into digital streams, which are then transmitted using hardware. GNU Radio has filters, channel codes, synchronization elements, equalizers, demodulators, vocoders, decoders, and many other elements (referred to as *blocks*) typically found in radio systems. More importantly, it includes a method of connecting these blocks and then manages how data is passed from one block to another. Extending GNU Radio is also quite easy; if a specific block is found to be missing, it can be quickly created and added.

Since GNU Radio is software, it can only handle digital data. Usually, complex baseband samples are the input data type for receivers and the output data type for transmitters. Analog hardware is then used to shift the signal to the desired center frequency. That requirement aside, any data type can be passed from one block to another—be it bits, bytes, vectors, bursts, or more complex data types. Figure 11.17 shows an example GNU Radio block diagram (19).

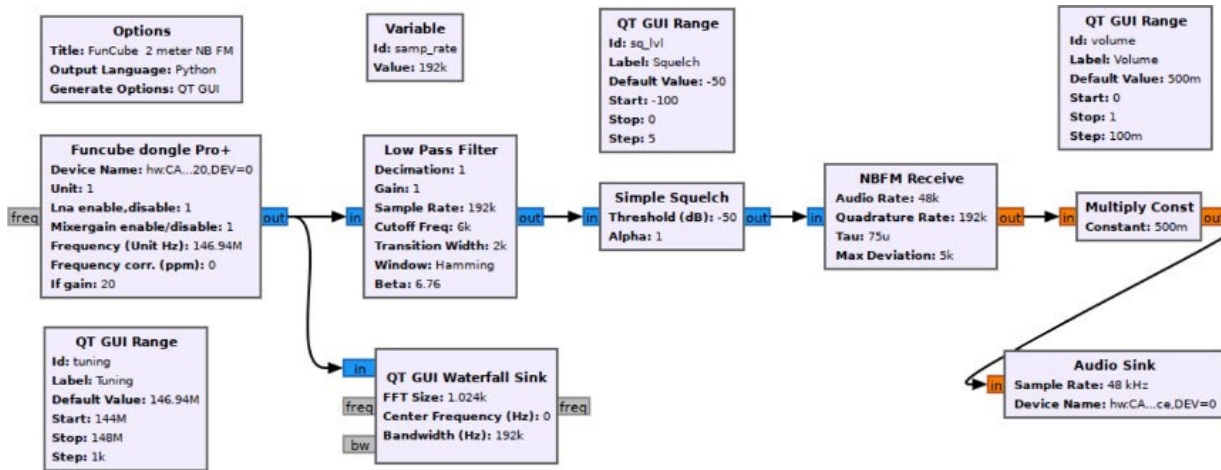


Figure 11.17: GNU Radio block diagram example for a 2-meter NBFM receiver. Credit: GNU Radio.

## HWCNTRL

HWCNTRL is a satellite ground station control program that is installed in more than 30 sites throughout the world. This automation software package can support multiple antennas and instruments simultaneously. Satellite passes are generated by user request based on the ephemeris set, and users can select specific passes to be added to the schedule. Scheduled events can be single-use or reoccurring on a daily or weekly basis. A control/status screen is accessible for each instrument in the system, and the user can view and change the settings of any instrument through these screens (20).

## 11.6 Mission and Science Operations Centers

The MOC is where all satellite commanding is generated, ground station control is managed, and satellite telemetry is archived. It is typically a physical location where everything required to operate the satellite is located. It is often in a secure room with controlled access to protect the satellite operating equipment and prevent unauthorized satellite control. Inside the room are typically several terminals so that multiple subsystem experts can be reviewing telemetry or running their analysis programs concurrently. An example of a MOC with multiple terminals is shown in figure 11.18.

The size of the MOC is determined by the complexity of the mission. There are more experts on during critical events or to resolve an anomaly. For a SmallSat mission, the complexity is usually lower and the MOC is a much smaller room. In addition to the terminals and telemetry analysis software are other resources for managing the satellite. These may include physical models of the satellite to study when contemplating anomalous telemetry. In the case of CubeSats, due to their small size, a functioning spacecraft engineering model may be useful to test commands and reproduce anomalies.

All tasking requests for future satellite operations are managed by the mission operations team. They will generate command plans, simulate satellite response to verify those plans, and if confidence in the simulations is not sufficient, they will run the commands on engineering model hardware prior to approving them for upload. The MOC team will also manage downloads. They will decide what ground resources are available when. If the MOC does not own its ground

stations, a request for contact will be submitted to the ground station managing company. The MOC submits data necessary for commanding the satellite for upload which includes commands and parameter settings for the payloads, a schedule of events for the flight computer, and ephemeris and pointing tables for the attitude control system along with its own timeline of events. When the contact is complete, the data will be sent back to the MOC by the ground station.

Prior to a launch, there will be rehearsals with everyone at their stations, and simulated telemetry with anomalous readings inserted will be used to test the team. This ensures that they are ready with the proper analysis software or integration test data available to quickly diagnose the problem and propose a plan of action. At the time of launch, the MOC will be fully populated, as this is a critical event. Telemetry will have to be interpreted and acted upon in short order.



Figure 11.18: MOC at NASA Ames Research Center. Credit: NASA.

The SOC is the focal point for all mission science data. The science team will use it to store and analyze the data. From that analysis, the science team generates satellite tasking requests that are sent to the mission operations team. External requests for additional data collection come through the science team first to assess feasibility with the instrumentation before tasking requests are made to the operations team.

The SOC is typically separate from the MOC. The payload developer will have their own operations center located at their facility with easy access to supporting resources. Before cloud data storage, the SOC was a physical place where data servers resided to archive the mission science data. Prior to secure network solutions, dedicated computers were located inside the SOC that would run programs written specifically to analyze the science data. If the mission was secure and the data classified, then the physical SOC would be protected behind a locked door. Missions that do not produce classified data can take advantage of a virtual SOC instead of a physical location and the science data and special programs for analyzing data can reside in the cloud. The virtual SOC allows scientists to log on from anywhere and perform work without the need to come to a physical location and pass through secure doors. In the future, as cyber security techniques improve, it is likely that more and more secure missions will be comfortable with the virtual SOC solution and only the highest classification missions will maintain a secure physical SOC.







passes, and interfacing with the MOC. One software computes the pointing direction by using a Two-Line Element set (TLE) to define the satellite motion, an accurate model of the pointing system mount, and GPS time. It generates motor commands as a function of time. The motor controller uses these commands to actively track the satellite during a pass. During the pass, another software suite is used to monitor the link, process and encode commands for transmission, handle any signal formatting or encryption, and demodulate and decode the received transmissions. This software also manages the network connection with the MOC over which the TLE is passed, as well as data for uploading and requests for data to be downloaded. When the contact is complete, the data received from the satellite is transferred back to the MOC. The ground station may also have its own telemetry for that contact. That data is used to trend its performance. Trending the performance of each contact provides insight and notice of degradation for both the satellite and the ground station. The ground station may also use scheduling software when handling multiple missions. This software uses orbit simulation and current TLE information to determine when the contacts are expected. It will indicate when there are conflicts between contact opportunities and can assist with schedule optimization. A schedule is generated for a given period and then programmed into the ground station control system for execution. This process can be automated, but there is typically an operator on staff to monitor the system.

For the MOC, mission planning software is necessary for missions that require complex satellite behavior such as pointing at a target during science data collection. The software will include a model of the satellite dynamics and the capability of its components. The event is planned by listing a series of actions that must occur in a certain order and are spaced out by times that are approximated. The software will simulate the satellite response and then the times and actions are iteratively adjusted as needed to optimize the plan and not cause a satellite fault condition. The output of the plan is all the commands and databases that are required by the satellite. This output is submitted to the ground station ingest software for upload at a time prior to the planned event.

The SOC uses software to handle the receipt, unpacking, reconstruction and post processing of the mission science data. Using an ISS payload as an example, the science data is downlinked via TDRSS to NASA Marshall Space Flight Center (MSFC) where it is separated into different science streams and piped to the correct payload SOC. At the SOC, but outside the company firewall, a computer is constantly running and ready to receive the data from MSFC. On that computer, the TRK software provided by NASA is running and it properly handshakes with the MSFC software assuring the data transfer. The science team periodically retrieves the data and safely brings it through the corporate firewall into the SOC. The science team writes parsing software to unpack the data which is stored in CCSDS format. They write another software to arrange the data back into the original image seen by the payload. Still more custom software will process the image to produce post-processed data products that are stored in the SOC archive and distributed to interested customers. The computer languages vary but Interactive Data Language (IDL) and Python are common choices for this type of software.

## **11.7 End-to-End Communications and Compatibility Testing**

A SmallSat undergoes various tests through its development cycle to verify proper functionality. For the communication subsystem, end-to-end communication and compatibility testing with the selected ground network is its most critical test. Compatibility testing verifies that the ground station can properly communicate with the satellite on the uplink and downlink RF channels. Ideally, compatibility would be validated by testing the flight spacecraft with the actual ground station that will be supporting the mission. This may not be practical for larger or high-cost satellites, due to logistics associated with shipping and risk of damage. Two alternatives to shipping the satellites are typically used. One includes sending a replicate set of ground station hardware to the satellite facility for testing. A second option is to test with only the flight or an ETU radio (also



common to include the flight computer) at the ground station or at a test lab configured with the ground station hardware. Drawbacks to the alternative options would include not testing the exact command path or determining whether ground sensitivity is sufficient.

For CubeSats, it is commonly feasible to bring the CubeSat to the ground station for testing. If that is not feasible, then at a minimum, the radio and flight processor (or Engineering Development Units [EDUs]) should be used. Testing at the ground station allows for the entire equipment chain to be part of the test, including the low-noise amplifier (LNA) and transmit/receive switch, if used. It is desirable to first test in a closed-loop configuration, where the satellite is connected to the ground system at the antenna port via a cable (with appropriate attenuators in line). If the satellite is fully integrated, disconnecting the flight antenna may not be feasible. In this case, a small monopole antenna located indoors near the CubeSat can be connected to the ground system. The monopole antenna connection to the ground system may vary depending on the ground antenna configuration but should include as much of the ground system electronics as practical.

Some missions elect to include an outdoor open-loop test with the CubeSat and ground antenna. This method allows for the entire ground system, including the ground antenna, to be included in the test. However, the ground antenna typically cannot point directly at the CubeSat due to mechanical limitations or to limit the received signal so the ground system RF components will not be overdriven. Off-pointing and reflections from the ground and local structures can also make it difficult to achieve a valid test.

End-to-end network testing primarily validates the ground station to MOC interface. This test verifies that the MOC can properly receive downlink data from the ground station and verifies that the ground station can receive and process uplink command data from it. Initial end-to-end testing will validate network connectivity, showing that network connections can be established and firewall rules at the ground station and MOC are in place. Once network connectivity is established, the MOC can transmit commands to the ground station for capture. The ground station can then transmit simulated or recorded data to the MOC for validation.

It is preferable to conduct initial end-to-end network testing prior to compatibility testing. In cases where the satellite can be brought to the ground station, a full end-to-end test can be conducted. Command transmissions from the MOC, through the network and ground system to the satellite can be validated. A complete end-to-end telemetry dataflow from the satellite to the control center can also be validated.

### **11.7.1 End-to-End Hardware for Ground Systems**

A complete ground system can be provided as a kit with all the necessary components bundled together and setup to work seamlessly. These end-to-end solutions include the antenna, its controller, and the RF feed with all the necessary filtering and low noise amplification for the particular wavelength of interest. They use a software defined radio or a dedicated transceiver to convert between digital packets and RF waveforms. Software is included to process the satellite position and direct the antenna to track it. Additional software is used to archive and display the information within the digital packets. Three vendors, GAUSS, Innovative Solutions In Space (ISISPACE) and GomSpace, listed in table 11-11 provide solutions for the low-cost CubeSat and small satellite market. One vendor, Surrey Satellite Technology Limited, offers a higher end system, installation service, and personnel support. The final vendor listed, Kratos, offers a different end-to-end solution that begins with the digitized RF waveform. The Kratos Quantum software then demodulates, filters, unpacks, parses, displays, and archives the data (17).



<b>Table 11-11: End-to-End Hardware for Ground Systems</b>			
<b>Product</b>	<b>Manufacturer</b>	<b>TRL</b>	<b>Type of Product</b>
Complete Ground Solution	GAUSS	9	Small satellite provider offering a complete ground solution. UHF, VHF, and S-band
Complete Ground Solution	ISISPACE	9	Small satellite provider offering a complete ground solution. UHF, VHF, and S-band
Complete Ground Solution	GomSpace	9	Small satellite provider offering a complete ground solution. UHF, VHF, and S-band
Surrey Ground Segment	Surrey Satellite Technology Ltd.	9	Major contractor who will install ground stations capable of S-band for U/L and D/L and X-band for D/L
Quantum	Kratos	9	Major contractor with a complete ground solution

### **GAUSS Ground Station Kit**

The GAUSS ground station is a turnkey solution. It can be configured with UHF, VHF and S-band on the same pointing system. An example of the associated hardware is shown in figure 11.20. Hardware features of the systems offered include (21-23):

- High gain Yagi-Uda VHF and UHF antennas (>16 dBi for UHF)
- Low-noise amplifiers and band-pass filters for VHF and UHF bands
- Low-loss RF coaxial cables
- 1.5-meter parabolic dish for higher frequencies downlink (up to 6 GHz, default feed is for S-band)
- VHF: uplink and downlink up to 100 W using radio and Terminal Node Controller (TNC), software defined radio (SDR) optional
- UHF: uplink and downlink up to 70 W, using radio and TNC, SDR optional
- TX using ICOM-9100 hardware, RX recording and decoding via SDR
- Several RF and electrical fuses for lightning protection
- S-Band: downlink using SDR for recording and post-processing of I/Q RF data
- Az/EI rotor for high-torque maneuvering
- Hardware components power switch on/off to minimize power consumption
- Full HD camera for instant antenna monitoring and picture logging

The features of the software that accompanies the system include:

- Automatic TLE download from publicly available repositories
- SGP4 propagator as suggested by USAF NORAD's Space-Track
- Rotor control (compatibility with several rotor controllers, e.g. Yaesu, RF Hamdesign)
- Assisted rotor pointing calibration and verification using Sun position
- Fully compatible with ICOM-9100 satellite radio and GAUSS USB ground dongle



Figure 11.20: (left) GAUSS ground station hardware, transceiver and (right) tracking antenna. Credit: GAUSS Srl.

- Separated Doppler shift corrections for uplink and downlink frequencies
- DUPLEX TX/RX mode
- Instant weather check and logging to operate the ground station safely
- Lightning detection for safe antennas operation
- Instant logging of all subsystems operation
- Ground map with live Earth clouds
- Compatible with several TNCs (Kantronics, Symek, Paccomm, Kenwood)
- Email report to ground station operators
- Instant email alerts for non-nominal conditions of the satellite or GS hardware components
- Session programming for weeks of unattended ground station operations
- GUI command recording for easy session programming
- One button programming to include a whole set of commands in the session
- Manual override during pass for last-minute command addition
- Control and handling of multiple satellites using configurable priorities
- Satellite TLM decoding, graphing, and archiving into a database accessible by web
- Integrated satellite payload data handling and decoding (e.g., for image file processing)
- TCP/IP connections for remote ground station & TNC operations

### **Innovative Solutions In-Space Ground Station Kit**

The ISISPACE small satellite ground station is a low-cost, turnkey solution that is designed to communicate with satellites in low-Earth orbit that operate in either amateur frequency bands or commercial bands. The frequency bands covered are S-band, UHF, and VHF. The ground station consists of an antenna and a 19" rack which houses the transceiver, rotor control and computer which make the system very compact. Examples of these components are shown in figure 11.21. The transceiver makes use of a SDR that provides flexibility to swiftly reconfigure modulation/coding/data-rate on the run. Most of the commonly used

modulation schemes and coding methods are already implemented, and any customization requests can also be handled (24).



Figure 11.21: (left) ISIS ground station hardware, transceiver rack and tracking antenna (right). Credit: ISPSPACE.

### GomSpace Ground Station Solutions

The GomSpace end-to-end solution is unique from other vendor offerings because a generic software defined radio is replaced with their AX100 or TR-600 radios, depending on the type of radio the in-orbit satellite uses to communicate. Using the same transceiver hardware on both sides of the link simplifies the configuration and validation testing steps in the integration and test (I&T) phase of the project. While the GomSpace solution does not work with satellites that do not use the GomSpace transceivers, the benefit is lower cost and simpler ground segment equipment (25). GomSpace also offers the Hands-off Operations Platform (HOOP), a satellite operations service to permit autonomous satellite operations for single spacecraft and constellations. The HOOP is compatible with GomSpace ground stations and leading ground station network providers and has been operational since 2020 (26).

### Surrey Satellite Technology Ltd. Ground Station Kit

Surrey can provide complete turnkey ground segment solutions for a range of space platforms, including all the hardware and software necessary to operate, maintain, process and archive data. Services provide by Surrey include:

- S- and X-band ground stations with full motion antenna systems from 2.4 meter to 7.3 meter in diameter, with radome options available for harsh climates
- SSTL Pilot Satellite Control Software
- Mission planning systems
- Radiometric and geometric image processing
- Data storage solutions
- Site surveys, groundsegment installation and training
- Technical and maintenance support packages

In addition, Surrey can work with customers to integrate their ground segment solutions with existing ground infrastructure or with 3rd-party ground station networks (27).

## Kratos Ground Station Solutions

The Kratos unique ground solution begins with their SpectralNet modem Digital IF product that converts analog signals at RF frequencies up to S-band into digital IF packets. It is the start of the Kratos digital processing product line chain. Kratos Quantum software operates on a fully digitized RF waveform. For example, a ground station service company would maintain the antennas and modems and use a very good internet connection to ship huge amount of data either into the cloud for storage and processing with the Kratos Quantum software, or to the customer MOC.

Kratos provides quantum as an integrated virtualized system supporting a satellite ground infrastructure architecture that is cloud and platform agnostic. Figure 11.22 provides a visualization for the system concept. All components are available separately to support an existing C2 solution or third-party ground network with existing signal processing and antenna resources. The quantum system includes:

- (1) quantumCMD for small spacecraft C2;
- (2) quantumFEP that connects C2 systems to RF signal processing equipment: handling command and telemetry stream formatting, encryption/decryption devices, CCSDS processing, and network interfaces to either quantumRadio or third-party ground antenna networks;
- (3) quantumRadio, the signal processing solution when C2 and digital front-end processing are already addressed quantumRadio, the signal;
- (4) quantumDRA a data recording and archiving application supporting CCSDS/non-CCSDS header and channel data routing with IP-based interfaces;
- (5) quantumRX, a fully virtualized wideband software receiver, specifically tuned to streaming Earth observations in near-real time with 600 MHz bandwidth using Digital IF digitizers;
- (6) quantumTX, a fully virtualized wideband software transmitter, specifically tuned for Earth Observation and Remote Sensing satellites with over 1Gbps throughput for uplinks.

QuantumRadio is a purely software modem for RF signal processing on the ground or in the cloud. It can be accessed from anywhere via the web with no client software to maintain or install. QuantumRadio supports a wide range of uplink/downlink frequency bands at low to high data rates and has been tested for compatibility on a variety of widely used space radios (28).

In 2021 Kratos introduced a virtualized architecture solution called OpenSpace. As an enterprise level, end-to-end system, it will provide the SmallSat community the flexibility to scale on-demand as their operations grow in size and capability. By leveraging Digital IF over IP with time, deterministic latency, and software defined networks, OpenSpace allows virtualized functions such as modems, channelizers, recorder and combiners to be orchestrated in a cloud environment. The virtual architecture lends itself to upgrades and/or updates automatically, ensuring ongoing reliability and security. In addition, the ability to test software releases in real-



Figure 11.22: Visualization for the Kratos quantum system concept. Credit: Kratos.

time, allows ground equipment strings to be included in continuous integration and continuous delivery cycles. Software defined architectures are more agile, programmable, and automated, enabling the ground system to work in tandem with dynamic satellite payloads. By shifting from RF signals and analog equipment to a virtualized, IP-based infrastructure, orchestration can occur on the fly. Figure 11.23 provides an illustration of the OpenSpace architecture concept (29).

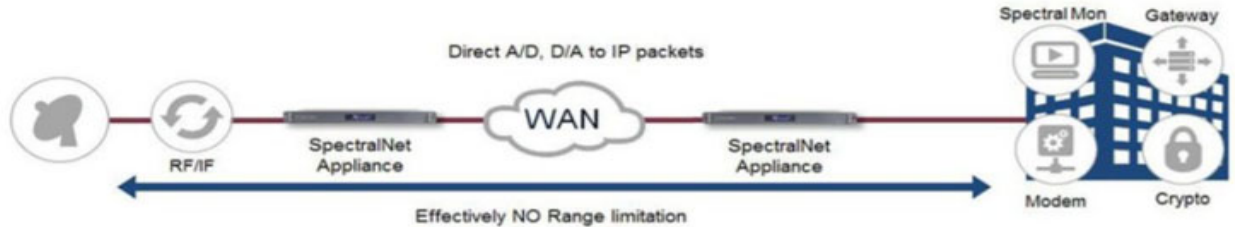


Figure 11.23: Kratos OpenSpace architecture concept keeps most of the RF ground equipment remote from the ground station. Credit: Kratos.

## 11.8 Cyber Security

Security of a space system needs to consider all aspects of the system, including the space platform, payloads, and all supporting functions. To a remote attacker, the most accessible portion of a spacecraft is the end-to-end command path as accessed through direct contact (RF link), subversion of any command path transports (space or ground networks), and subversion of the command authority (e.g., MOC). Another enticing option for an attacker is to cause a mission impact through manipulation of key space system dependencies, such as the Global Navigation Satellite System (GNSS), ground stations, and external service or data providers. Related concerns include degrading or denying the use of the command path through jamming or denial of service of the command path and supporting functions. Finally, vulnerabilities in any system, sub-system, or component, can be exploited by an attacker in creative ways to ultimately gain the ability to affect the overall system. Supply chain risk management is needed to address some portions of these challenges.

Effective space system security efforts begin early in the lifecycle and continue through to mission termination. Early architecture and design decisions will have the most significant impact on the overall system's security outcomes and can help avoid rework in later phases. Integrating cybersecurity capabilities into a system fits well into standard system engineering practices. Many organizations are establishing a sub-discipline for systems security engineering, to serve as a focal point within the mission team to enable system security. This may overlap with or work closely with related roles such as a cybersecurity systems engineer. The International Council on Systems Engineering (INCOSE) has established a working group to support system security engineering, and NASA is actively implementing a system security engineering capability (30).

Operators need to maintain command authority over their spacecraft, preventing unauthorized access. Use of authenticated encryption, between the point where the command sequence is generated and the spacecraft, is the best method to ensure command authority and data integrity. Encryption provides confidentiality, and authentication ensures that a trusted source initiated the command. This approach generally addresses initial concerns about an attacker attempting to gain access through use or subversion of the command path to the spacecraft.

Key spacecraft external dependencies can be manipulated to cause a mission impact. Example dependencies might include the ground station and GNSS signal. Ground station impacts could disrupt data flows with the spacecraft. Jamming and measurement spoofing of GNSS signals has become common in various regions, with observed impacts in the maritime and airspace domains.





Orbiting systems have detected similar effects. Space systems should be prepared to tolerate loss or interference with GNSS signals.

For the overall space system and its component parts to function properly and securely, each part must in turn be sufficiently secure. Traditional cybersecurity efforts apply well to most software and terrestrial systems. Attention to the security of each component, as well as ensuring the interplay between components is secure, will help protect the overall system. On-board security should also be considered, particularly for multi-customer and multi-payload spacecraft. Increasingly, spacecraft developers should consider that external defenses (e.g., command authentication or encryption) may be bypassed or subverted (similar to how network firewalls may be bypassed). Without further consideration, the on-board systems are likely vulnerable to further exploitation.

Supply chain risk management is an essential related discipline. Particularly for key components and software, understanding the vendor's sourcing, manufacturing approach, and cybersecurity and assurance management will help ensure any associated risk can be identified and managed. If a vendor relies on other vendors, additional scrutiny may be appropriate. Review of the sourcing may address whether the vendor is rebranding, assembling/integrating, or internally manufacturing components, and whether there is sufficient control to deliver a trustworthy product. Reviewing the manufacturing approach, whether hardware, software, or some combination, allows the customer to determine whether the vendor uses repeatable processes that yield deterministic and trustworthy results. And understanding how the vendor addresses cybersecurity, quality, and protection topics in their components provides insight into whether or not it is appropriate to integrate the component into the overall system.

### **U.S. National Guidance and Regulations**

In September 2020, the U.S. National Space Council issued Space Policy Directive 5 (SPD-5), Cybersecurity Principles for Space Systems. Amongst other elements, the directive calls for use of "risk-based cybersecurity-informed engineering," anticipating and adapting to evolving malicious activities, and recommending capabilities to maintain positive control of space vehicles. Another element implies that Federal agencies may issue or update guidance, rules, or regulations to adopt the principles in this directive (31).

U.S. regulatory agencies, such as the Federal Communications Commission (FCC), have considered and not yet issued rules that may require specific cybersecurity measures to be adopted. Prior proposed (and not issued) rules included requirements for encryption on the telemetry, tracking, and command communications for propulsive spacecraft.

### **U.S. Agency Guidance**

Several U.S. government agencies and their support ecosystem have made various frameworks, standards, and other guidance available to address cybersecurity and protection concerns.

### **NASA Technical Standard**

NASA requires its missions, including small satellites, to comply with NASA STD-1006 "Space System Protection Requirements." This standard covers protection of the "command stack," critical information, Position Navigation and Timing (PNT) sub-system resilience, and reporting detected and unexplained interference. The tailoring guidance within the standard allows for some flexibility in certain small satellite scenarios, such as non-maneuverable systems. Protecting the command stack involves use of encryption complying with FIPS 140 (level one). PNT resilience addresses the loss of or temporary interference with external PNT services, such as a GNSS (32).



## **National Institute of Standards and Technology (NIST)**

NIST has several useful publications addressing cybersecurity and system security engineering. The NIST Cybersecurity Framework is a voluntary guidance framework that can be used by organizations to manage cybersecurity risk. The framework provides a structured and tailorable approach for organizational security capabilities and includes informative references to other NIST documents (e.g., SP 800-53), as well as other standards or guidance organizations (e.g., International Organization for Standardization, ISO). NIST's SP 800-160 Volumes I and II offer a thorough approach for system security engineering practices. In particular, SP800-160 Vol I's Appendix F, Design Principles for Security, can be used as an effective foundation for systems security (33-36).

### **Additional Resources**

Two U.S. Federally Funded Research and Development Centers (FFRDCs), the Aerospace Corporation (37) and MITRE (38), have published guidance for space system cybersecurity. These FFRDCs are expecting to make additional recommendations widely available. Aerospace's "Defending Spacecraft in the Cyber Domain" includes a brief survey of known cybersecurity initiatives and standards, challenges with legacy engineering approaches, emerging threats, and principles for "cyber-resilient spacecraft." The paper also includes a section specific to small satellites. MITRE has published a paper "Cyber Best Practices for Small Satellite" that briefly addresses cyber threats to space systems and includes a discussion on applying lessons learned from other industries to space systems.

### **Consultative Committee for Space Data Systems (CCSDS)**

CCSDS provides a variety of guidance documents for implementing security measures in various aspects of the mission. For an introduction to the CCSDS approach and available guidance, see CCSDS 350.7-G-2 "Security Guide for Mission Planners" that provides a perspective on approaching security in space systems (39). The CCSDS 350.0-G-3 "The Application of Security to CCSDS Protocols" informative guidance document provides an introduction and discussion on various topics, including protecting the command path (40).

## **11.9 State-of-the-Art – Ground Data and Supporting Systems**

### **11.9.1 Technologies**

#### **Multiple Spacecraft Per Aperture**

The Annual Small Satellite Conference on the grounds of Utah State University is the premier event amongst small satellite stakeholders, and its themes reflect the trends of the times. In 2021 one of the key talks was on how to "Maximize Contact Availability of SmallSat Clusters through MSPA Technique on GSaaS," (41).

As scientists are increasingly interested in characterizing fields (going beyond single point measurements) requiring swarms of satellites, as well as the emergence of Distributed Satellite Missions (multiple satellites working in concert towards one common goal), MSPA is a critical enabler. While it is not a new concept, few ground stations have invested in such upgrade. The DSN has the capability to track multiple spacecraft per antenna (MSPA) (up to four) if they are all within the scheduled antenna's beam. The 34 m antennas at each complex can be combined into an array, with or without the co-located 70 m antenna. The combined G/T depends on several factors but is approximately increased by the sum of the antenna areas from the arrayed apertures minus approximately 0.3 dB combining loss. For instance, arraying four 34-meter antennas results in an increase of 5.72 dB.

## Automation and Modeling

The MOC of the future will include a “lights out” or fully automated option. This requires software on the ground station side to run the antenna automatically. Automation software will receive a list of times that the antenna should track the satellite and it will manage that list. It will send TLEs and data to the antenna with no one present, receive downlinked telemetry, and archive it. Software automatically parses the telemetry, compares key watch items to defined limits, and alerts the team via email or phone text message. FreeFlyer by a.i. solutions combines astrodynamics/ spacecraft propagation, coverage and contact analysis (including swarms), attitude and maneuver modeling and orbit determination (42).

## Large Ground Antennas: to the Moon and Beyond

For years there had been a gap between NSN’s largest 18m and DSN’s 34/70m antennas, and such large antennas were not available from commercial ground providers. This gap has now been filled.

In 2022 Viasat introduced “new 19/24m aperture antennas (figure 11.24) at their Antenna Systems campus in Duluth, GA supporting several ongoing programs. The size and architecture of these larger apertures support not only current programs but offer the flexibility as well as scalability to support future and forward planning missions.” (Bill Lawyer, Business Development Director at Viasat, Inc.) (43).



*Figure 11.24: Viasat’s new Large-Aperture Space-to-Ground Communication Antennas ready to support Lunar, Cislunar, Deep Space and DoD Missions. Credit: Viasat.*

## NASA Lunar Exploration Ground Sites (LEGS)

SCaN announces the LEGS with its mission is to provide direct-to-earth communication and navigation services for missions operating from 36,000 kilometers (km) in the GEO to cis Lunar and other orbits out to 2 million km. To fully support distant orbits there will be three LEGS sites equally spaced around the Earth. The Ground sites use CCSDS Modulation and coding schemes for forward and return data. Specialized/unique Mod-Cods are optional. User Local Equipment on-site is optional. The 18m assets are listed as White Sands, USA: 32.544863, -106.612504



Matjiesfontein, South Africa: -33.231224, 20.58163 (TBD) and Pacific Region TBD. MSPA is planned for up to 4 simultaneous return services per aperture (Max 3 for Ka). Use of LEGS for other than Artemis support is TBD. See table 11-12 for projected performance of LEGS assets.

**Table 11-12: Projected Performance of LEGS Assets Pending Finalization**

RF Performance Criterion	Radio Frequency Performance (Return)		
	S-Band	X-Band	Ka-Band
G/T (minimum)	28 dB/K	39 dB/K	47.5 dB/K

### 11.9.2 Ground Aggregators

Section 11.4 lists those Ground Service providers who own and or operate their own brand of ground assets. Irrespective of the nature of ownership, satellite operators are reliant on the limited ground stations they have access to. Satellite operators have well defined windows for exchanging information with their satellites. To meet evolving demand from within the fast-growing segment of the space industry, multiple aggregator models have evolved from private market participants. Services from companies such as RBC Signals, Infostellar, Amazon Web Services, and Spaceit are offered through specialist ground station capacity aggregator platforms. These are digital solutions enabling ground station operators to provide their excess capacity to a global user base. Since this is very similar to the business model of Uber, these aggregator services represent the ongoing “Uber-ization” of ground station services within the space industry. The downstream service markets are observing new players with new products and services. With increasing competition, the differentiating factors are shrinking in number. When the upstream capabilities start resembling each other, the key differentiators will include the ability to communicate with the satellites on-demand (44).

#### RBC Signals

RBC Signals is a global space communications provider serving government and commercial satellite operators in GEO, low-Earth orbit, & MEO with an improved model for the delivery and processing of data from satellites in orbit (see <https://rbcsignals.com/>). The company’s worldwide network includes both company-owned and partner-owned antennas, capitalizing on the sharing economy model, for best-in-class services offering affordability, flexibility, and low latency. Their team has deep relationships across the entire space value chain and decades of experience building, operating, and maintaining ground stations for the direct reception and processing of Earth observation satellite data.

RBC has aggregated a growing network of over 70 antennas in nearly 50 locations worldwide offering unmatched capabilities. A map of these locations is shown in figure 11.25. As of 2022, RBC owns about 15% of the ground stations, and the rest are partner stations. For customers needing turnkey access to existing antennas, RBC Signals offers ground station antenna-as-a-service, with the flexibility to secure unlimited satellite passes (“core”) or ‘pay-by-the-pass/minute/GB’. This is made possible through a combination of their own network of highly capable systems and the unique ‘sharing economy’ model, wherein they leverage the unused excess capacity of dozens of partner-owned antennas worldwide. RBC Signals also offers turnkey bring-your-own-antenna hosting solutions that pair customer- owned equipment with reliable, high-end ground infrastructure almost anywhere in the world. RBC employs a distributed compute architecture where most processing occurs at a data center/cloud, with some processing on the satellite or at the terrestrial edge at the ground station. RBC Signals can host AWS and Microsoft on premise cloud infrastructure, as well as virtual servers at the ground.

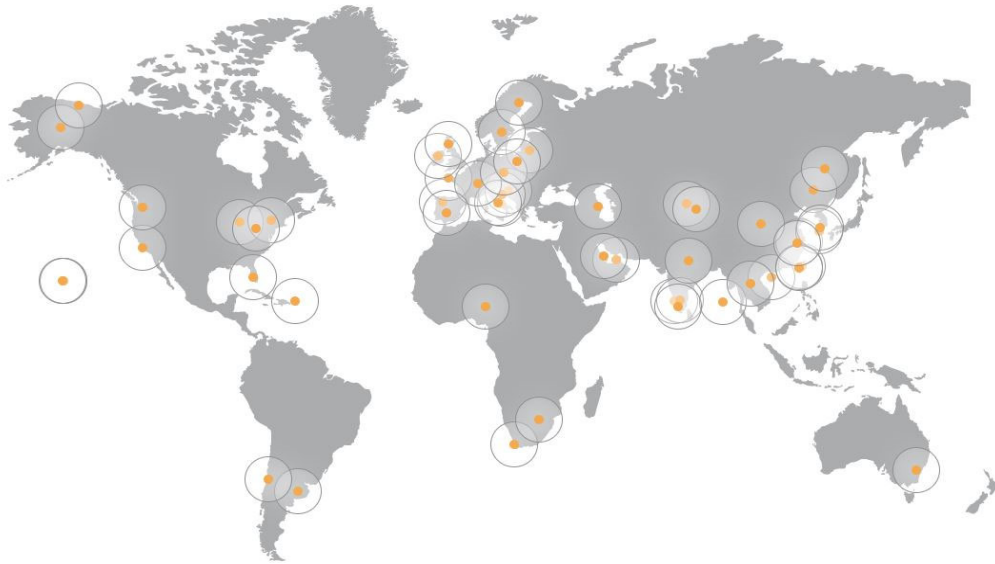


Figure 11.25: RBC Signals ground network map. Credit: RBC Signals.

### Atlas Global Network

ATLAS Space Operations, Inc. is a U.S. owned, non-traditional small business that provides satellite RF communications services to the government and commercial sectors (see <https://atlasground.com/>). Through geographical dispersion and cloud services, ATLAS Space Operations provides a resilient capability that delivers low latency data. Integral to the ATLAS mission success model is a global network of operational ground sites, which work together as a mission architecture to meet customer requirements.

All ATLAS ground stations are built upon the Freedom™ Software Platform (figure 11.26), which facilitates dynamic demand and scalable growth. ATLAS' Global Antenna Network is fully integrated with the Freedom™ Software, providing users low latency, secure communications solution. Including: automated network operations, set-and-forget scheduling, mixed modem capability, real-time metrics, and single secure VPN access. Once integrated into the ATLAS Network, a single secure VPN enables access and load balancing of network resources. Freedom™ Core Services advance operations beyond legacy constructs and enable users the freedom and flexibility to reliably schedule satellite passes with minimal human interaction. Entire data processing and forwarding workflows can be automated within the cloud to ensure your data is ready for use as soon as it arrives at the Mission Operations Center.

Atlas supports deploying clusters and serverless instances onto Amazon Web Services (AWS). Atlas hardware parameters are found in table 11-13. In addition to S- band and X-band capabilities, ATLAS can provide VHF, UHF services in Japan and Guam. The existing and planned ATLAS antenna systems support RF connectivity for low-Earth orbit, MEO, GEO, and L1 orbits, and ATLAS is actively pursuing technology development for deep space capabilities. Figure 11.27 shows the ATLAS Space Operations network map for current and future sites. Potential sites for future hybrid RF/optical ground stations include: Yuma, NM; Malaga, Spain; Cape Town, S. Africa; Kenya; Botswana; Alexandropoulos, Greece; and Alice Springs, Australia.

A summary of government and commercial ground systems and aggregators is in table 11-14.

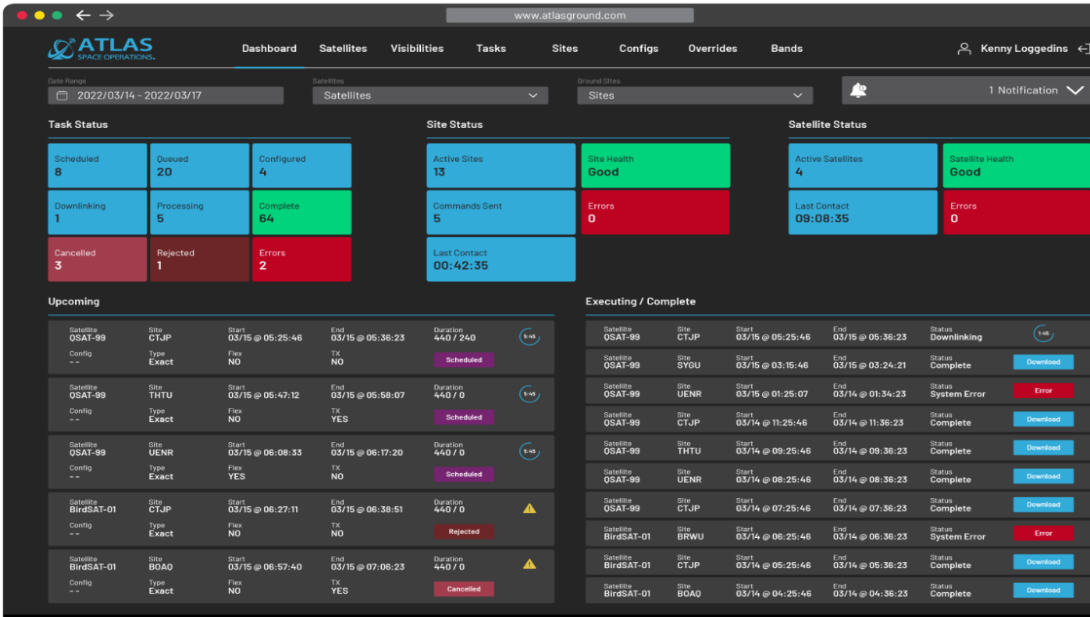


Figure 11.26. The Freedom™ Software Platform is a simple and scalable ground network management system. Credit: ATLAS Space.

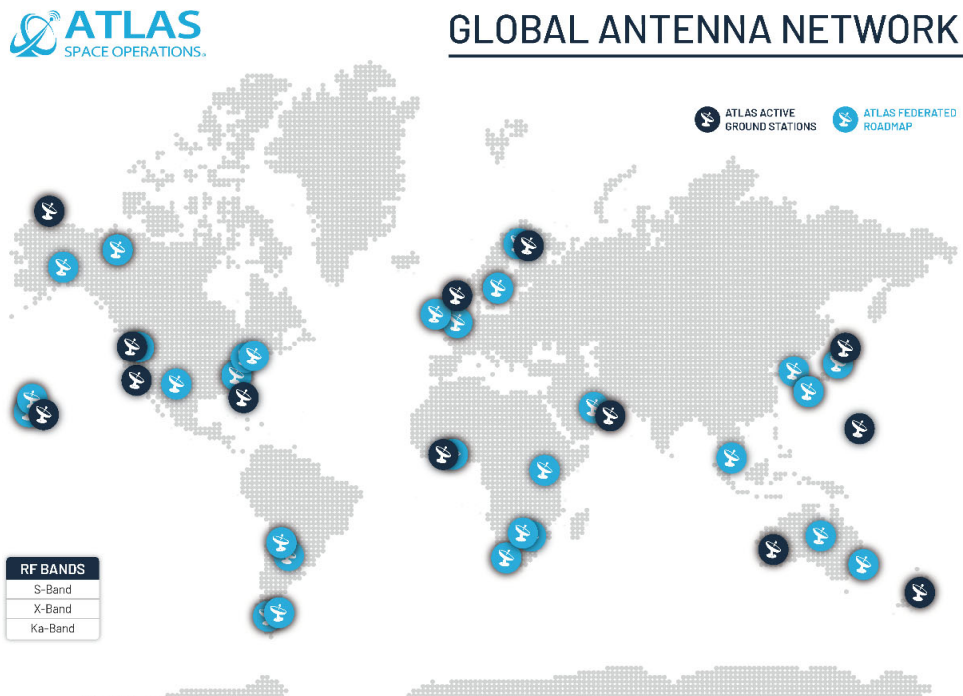
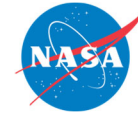


Figure 11.27: ATLAS Space Operations ground network map. Credit: ATLAS Space Operations



**Table 11-13: ATLAS Worldwide Ground Station Network**

<b>Atlas Network</b>	<b>Dish size</b>	<b>S-band Tx</b>	<b>S-band Rx</b>	<b>S-band G/T</b>	<b>X-band D/L</b>	<b>X-band G/T</b>
<b>Locations</b>	m	MHz	MHz	dBi/K	MHz	dBi/K
Utqiagvik (Barrow), AK	3.7	2025-2110	2200-2300	12.8	7900-8400	26.4
Sodankylä, Finland	7.3	2025-2110	2200-2300	19.81	7750-8400	32.11
Dundee, Scotland	3.7	2025-2120	2200-2400	3.6	7800-8400	26.5
Brewster, WA	7.6	2025-2120	2200-2300	11.3	7900-8500	31
Chitose, Japan	3.4	2025-2120	2200-2300	10.89	7900-8500	25.91
Mojave, CA	3.0	2025-2110	2200-2300	11.31	7900-8500	25.93
Miami, FL	11.3	-	-	-	8000-8500	35
Dubai, United Arab Emirates	3.7	2025-2120	2200-2300	12.8	7900-8500	25.4
Harmon, Guam	3.7	2025-2110	2200-2300	13.68	7900-8400	26.15
Sunyani, Ghana	3.0	2025-2110	2200-2300	12.4	-	-
Tahiti, French Polynesia	3.7	2025-2120	2200-2300	13.96	7900-8400	27.48
Mingenew, Australia	5.0	2025-2120	2200-2300	14	8025-8400	29.5
Awarua, New Zealand	3.7	2025-2120	2200-2300	13.7	8025-8400	27



<b>Table 11-14: Service Providers for DTE Ground System Network</b>			
<b>Product</b>	<b>Dish Sizes</b>	<b>Services</b>	<b>MSPA</b>
ATLAS Global Network	Various partners with other stations	S-band, X-band, UHF (Ka-band in 2017) Built on AWS cloud infrastructure	Partner dependent
KSAT and KSAT lite by Kongsberg Sat. Services	> 10 m part of NSN or 3.7 m (KSATlite)	X-band and S-band D/L and S-band U/L. VHF, UHF, Ka-band D/L. KSATlite designed specifically for SmallSats	No
SSC Infinity by Swedish Space Corporation	13 m 7.3 m NSN partner	Designed specifically for SmallSats; Uses standardized HW	Not found
AWS Ground Station by Amazon	5.4 m	Built on AWS cloud infrastructure	Not found
Viasat	7.3 m 5.4 m		No
Leaf Space	3.7 m		Yes
NASA, Near Space Network	9 to 11 m, & 5 m	Global network operating in S, X, and Ka- bands that can reach LEO, GEO, HEO, and Lunar orbits; up to 2 mil km	Legacy: NoLEGS (18m): planned, Yes
NASA/ JPL, Deep Space Network	34 m & 70 m	Operating at S, X, K, Ka bands. Includes Morehead State 21m in X-band. 8 m optical receive aperture planned for 2030s	Yes
NASA UHF Ground Station	18 m	Operates in UHF (400 – 470 MHz)	No
RBC Signals Global Ground Station Network		VHF, UHF, S, C, X, Ku, and Ka-bands	Partner Dependent

### 11.9.3 Scheduling and Mission Operations Software

With the growing number of ground operators and aggregators, to take advantage of the plethora of assets, scheduling is emerging as the single most important enabler. As individual providers may have their own scheduling formats, for seamless operations, a common scheduler is critical, and this is true for the NASA commercialization efforts as well. The Atlas Freedom™ Software Platform (figure 11.26) is a good example for an aggregate scheduler. Additional scheduling platforms are presented below.

#### Scheduling: InfoStellar

InfoStellar offers the following services in UHF, S and X-bands. A simple selection from the GUI



(e.g., X-band downlink, S-band uplink) returned 10 live and 13 planned ground stations (figure 11.28). Table 11-15 lists the frequency bands offered by InfoStellar.

Table 11-15: Select Frequency Bands by InfoStellar			
Downlink		Uplink	
X Band 8 – 12GHz	S Band 2 – 4GHz	S Band 2 – 4GHz	UHF Band 300MHz – 1GHz
UHF Band 300MHz – 1GHz	None No Uplink Channel	VHF Band 30 – 300MHz	None No Uplink Channel



Figure 11.28: The StellarStation Ground Station Search Tool returned 10 live and 13 planned ground stations offering X and S band communications. Credit: InfoStellar.

With multiple commercial small-satellite operators in the market, the need for enhanced mission operations is much more than an industry-wide requirement (44).

The following section provides an overview of mission operations and scheduling software products that can be integrated into a MOC (see table 11-16). While the specific aspects of each of these products is discussed below, they all have some common features. In general, these software applications cover functions related to mission scheduling and tasking, commanding and telemetry, and monitoring and control. Many of them also have automation features that enable “lights-out” operations or reduced manpower requirements.

All these products are highly customizable. They can not only adapt to multiple missions, satellites, and ground stations, but these products also allow for customized visualizations, analyses, and user interface views. Additionally, many of these products are cloud-based or have a web interface to enable easier access for an operator from almost anywhere.



<b>Table 11-16: Mission Operations and Scheduling Software</b>			
<b>Product</b>	<b>Manufacturer</b>	<b>TRL</b>	<b>Type of Product</b>
COSMOS	OpenC3	9	Open-source command and control system that can be used in all phases of testing and operations
Galaxy	The Hammers Company	9	Command and telemetry system that has been available since 2000
Orbit Logic Family of Products	Orbit Logic	9	Group of mission planning and scheduling products for both aerial and satellite imaging applications
ACE Premier Family of Products	Braxton Technologies	8+	Group of hardware and software components for end-to-end Satellite Operations Center (SOC)
Mission Control Software	Bright Ascension	8+	Monitoring and control interface with “lights-out” automation features built-in
Major Tom	Xplore	8+	Cloud-based command and telemetry system that can interface with some COTS flight software

### **OpenC3 COSMOS**

OpenC3 COSMOS is a free, open-source, open-architecture, command, control and communications system providing commanding, scripting, and data visualization capabilities for embedded systems and systems of systems. With the release of version 5, COSMOS is now a fully containerized and microservice based architecture, with a web frontend. COSMOS is intended for use during all phases of testing (board, box, and integrated system) and during operations. OpenC3 COSMOS is made up of a set of applications that can be grouped into four categories: real-time commanding and scripting; telemetry visualization; offline analysis; and utilities. Figure 11.29 shows how data flows through the microservices and is made available to users through an API and from a web-based interface. Any embedded system that provides a communication interface can be connected to COSMOS. All real-time communications of both commands and telemetry are logged in a cloud-native data store, which can use local hardware, or cloud-based buckets for potentially infinite storage. Additionally, program specific tools can be written using the open-source OpenC3 COSMOS libraries, and these tools can interact with the commands and telemetry of all targets connected to the system as well (45).

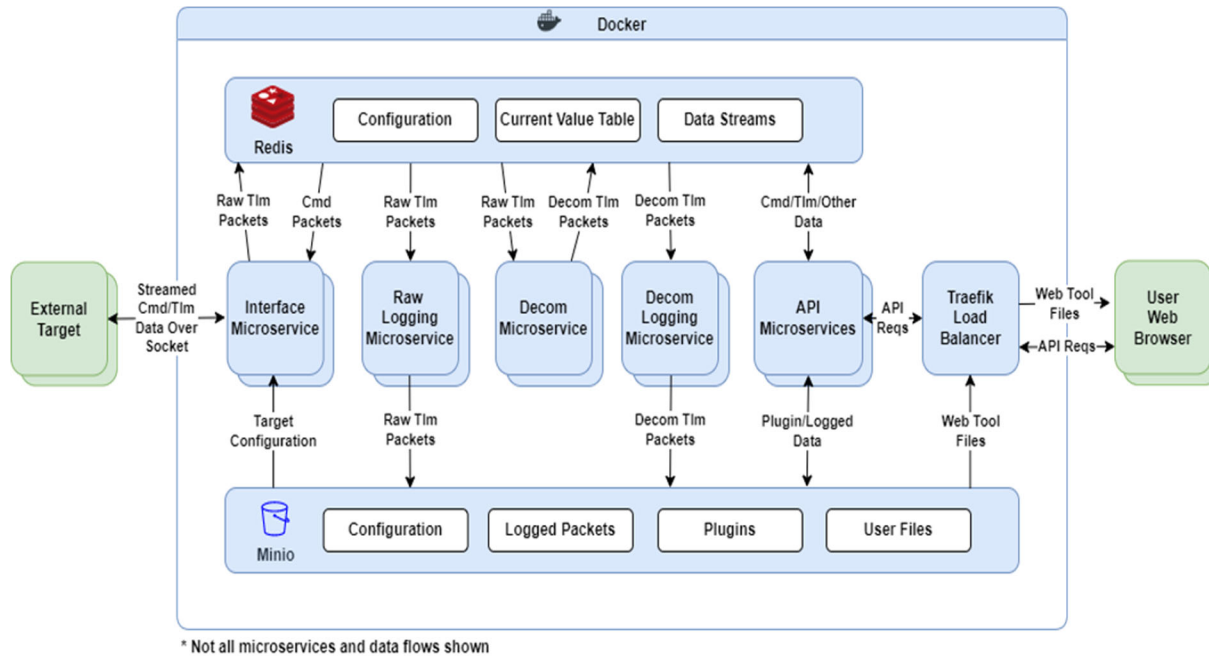


Figure 11.29: COSMOS5 architecture and context diagram. Credit: OpenC3, Inc. <https://openc3.com/>

## Galaxy

Galaxy is a command and telemetry system that is derived directly from the Integrated Test and Operations System (ITOS) telemetry and command system developed by the Hammers Company with NASA GSFC. It has been available commercially since 2000. Galaxy can accept telemetry from, and send commands to, multiple spacecraft and ground stations simultaneously. Users can customize Galaxy for a particular mission via a database in which they provide telemetry and command specifications. Users can design telemetry displays, plots, sequential prints, configuration monitors, and spacecraft commands and table loads in simple text files stored on the computer's file system. Most displays can be viewed remotely over the web or by using remote Galaxy instances. Additionally, Galaxy is CCSDS compliant, and it can communicate over a wide variety of transports and protocols including TCP/IP networking, synchronous and asynchronous serial ports, SpaceWire, military standard (MIL-STD-1553), and the GMSEC message bus (46).

## Major Tom

Major Tom is a commanding and telemetry system that allows operators to use the same tool, workflow, and processes during development, testing, and operations. Key features include simplified dashboards for commanding and telemetry data; an API that allows an operator to build custom automation; and the ability to support multi-satellite operations. Major Tom leverages a cloud-based deployment for simplicity and can be integrated with some COTS ground stations and flight software, including Xplore's own open-source flight software. Figure 11.30 provides a screenshot of the user interface (47).

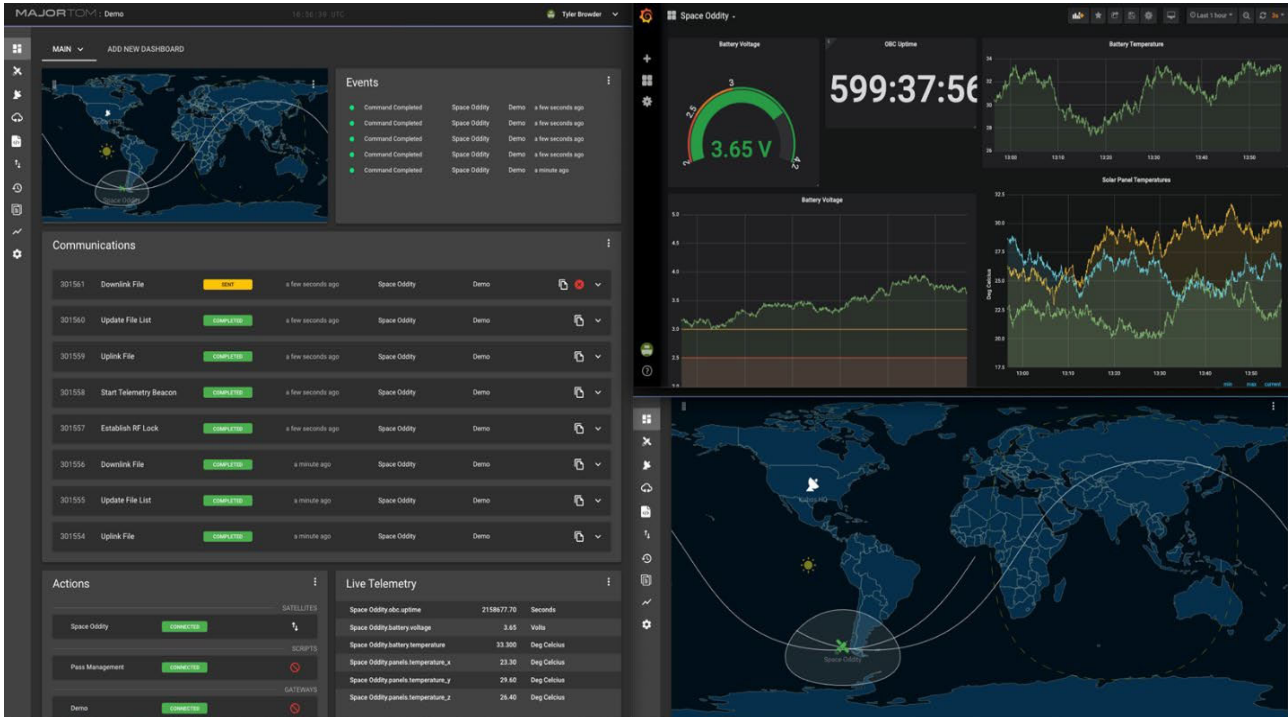


Figure 11.30: Major Tom user interface screenshot. Credit: Xplore.

### Orbit Logic Family of Products

Orbit Logic specializes in mission planning, scheduling, and space situational awareness software. The software suite consists of multiple applications that support analysis and operations for aerial and satellite imaging and space-to-ground networking. The mobile, web, desktop, and onboard scheduling applications have a variety of features, including: configurable systems, constraints, and goals; high performance algorithms; deconflicted scheduling plans; visualizations and animations on the user interface, and flexible process flows and automation. Figure 11.31 provides a screenshot for Orbit Logic’s Collection Planning and Analysis Workstation (CPAW) (48).

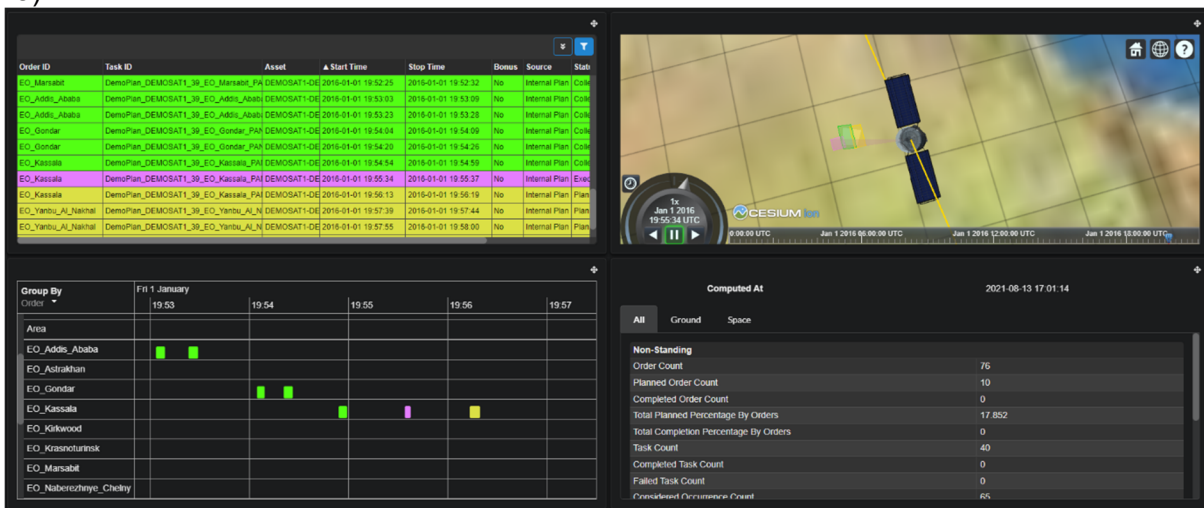


Figure 11.31: Orbit Logic CPAW dashboard. Credit: Orbit Logic.



## ACE CrtIPoint

The ACE CrtIPoint from Parsons (acquired Braxton Technologies January 2021) is an automated space vehicle and ground station command and control (C2) application with a plug-in architecture that provides nearly lights-out TT&C operations. ACE CrtIPoint includes the hardware and software components necessary for a satellite MOC. Key applications include: integration with antenna scheduling; ground station control and status; data forwarding for analysis; command plan execution; anomaly detection; and a turnkey TT&C system. COTS capabilities plug into standardized environments, allowing the product to be ready immediately within a range of mission architectures (49).

## Bright Ascension Mission Control Software

Bright Ascension's Mission Control Software (MCS) ground software provides a monitoring and control interface to implement changes during development and flight. An example of the interface is shown in figure 11.32. MCS consists of an integrated graphical environment with dedicated views and layouts that can be created, saved, and customized for different stages of the mission. MCS also supports a wide range of ground station interfaces and protocols to fit both in-house and commercial ground stations. Additionally, MCS includes automation features to enable unattended (or "lights-out") operations (50).

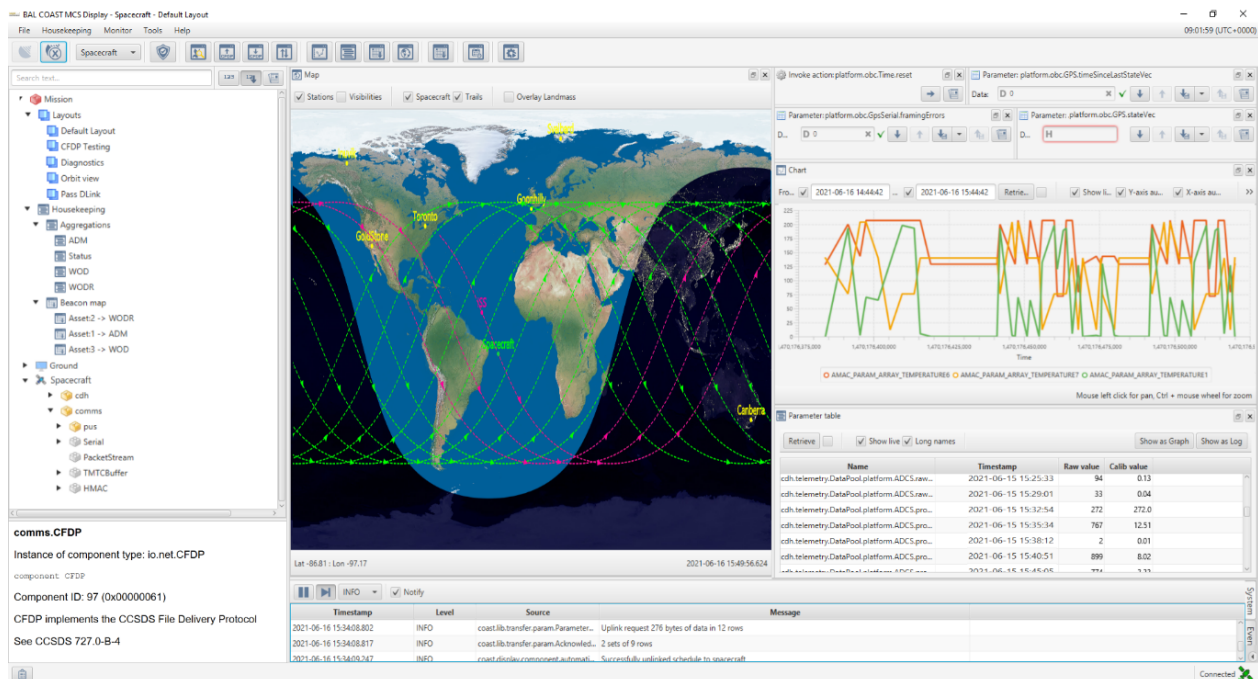


Figure 11.32: Bright Ascension Mission Control Software interface screenshot. Credit: Bright Ascension.

## 11.10 On the Horizon

Ground data systems must continue to evolve to keep up with the furious pace of small satellite technology. Advancements in onboard processing and data storage will demand more capability in getting data to the ground. Mass production of small satellites is quickly becoming a reality and large constellations are now starting to find their way to orbit. This will require ground system technology that can communicate with multiple satellites simultaneously. Free Space Optical



communications and phased array ground systems are emerging solutions to these needs. While both technologies have seen years of investment, they are now just starting to find their way into the ground networks. While it may still be years before becoming a staple for these networks, the following sections provide insight to the state of these technologies and where they are headed in the future.

### **11.10.1 Free Space Optical Communications**

Increasing demand for data from NASA missions has led to a migration over the past few decades to increasingly higher RF bands (X, K, and Ka) and ultimately to the optical and near-infrared regime. Free Space Optical (FSO) communications are expected to increase data rates by two orders of magnitude over traditional RF links (see Communications chapter for more on FSO communications). The next generation systems will incorporate optical communications, and several early flight demonstrations and uses of optical communications in the coming decade are expected to be transformational for NASA and other space organizations. Whereas Ka-band frequencies go up to 40 GHz frequency, the optical signal reaches up to 200,000 GHz. Higher frequencies have the potential for huge increases in data rates, theoretically proportional to frequency-squared if all other factors are equal. At optical wavelengths, other factors, such as atmospheric losses, receiver sensitivity, aperture, and power, must also be considered, but nonetheless, optical communications offer the potential for orders of magnitude improvement in data throughput.

For space applications, lasers are being used as the light source. Laser systems with dynamic systems such as fast-steering mirrors are used to accurately point the laser on the spacecraft to the ground terminal. Other methods using laser arrays for beam pointing are also being developed to reduce the need for complex dynamic systems. Data is transmitted in the form of hundreds of millions of short pulses of laser light every second. The light is made of photons and the optical ground terminals are setup to collect the light at the photon level. In fact, the ground terminals are designed for an environment where relatively few photons may be received from the transmitter spacecraft, especially from deep space. Direct photon detection with Pulse Position Modulation (PPM) is used instead of the common RF technique of direct carrier coherent modulation to convey information. PPM modulation uses a time interval that is divided into a number of possible pulse locations, but only a single pulse is placed in one of the possible positions, determined by the information being transmitted. To detect extremely faint optical signals with relatively few photons through the atmosphere, optical ground stations can use a superconducting nanowire single photon detector (SNSPD), which, to increase the sensitivity of the nanowires, uses a 1-Kelvin cryocooler. A real-time signal processing receiver uses time-stamped photon arrivals to synchronize, demodulate, decode, and de-interleave signals to extract information code-words. Hence, while the specific technologies employed differ in some respects from those used in radio frequency ground terminals, the higher-level functions performed by the optical communication ground terminal are similar.

Optical communication is attractive for mission designers using small, resource-constrained spacecraft, because it offers a path to relatively high data rates with relatively small, low-power spacecraft equipment. The same volume and power savings can be experienced on the ground terminal side as well. This is driven by the size of the wavelengths. Because RF wavelengths are longer, the size of their transmission beam covers a wider area, therefore, the capture antennas for RF data transmissions must be very large. Laser wavelengths are 10,000 times shorter, allowing data to be transmitted across narrower, tighter beams. This results in the ability to deliver the same amount of signal power to much smaller collecting areas. The reduction in antenna size applies for ground and space receivers, which allows for size and mass reductions on the spacecraft side.



NASA made great strides with its optical communication demonstration on the Lunar Atmosphere and Dust Experiment Explorer (LADEE) mission. The pivotal NASA Lunar Laser Communications Demonstration (LLCD) was able to achieve 622 Mbps from a lunar distance. NASA has several exciting optical communications demonstrations, including O2O, Illuma-T, T-Bird and the Laser Communications Relay Demonstration (LCRD). LCRD is supported by Optical Ground Station (OGS)-1 at OCTL, and OGS2 in Hawaii (51).

Northern Sky Research (NSR) predicts growth for optical communications, which needs to be matched by OGS (figure 11.33). “The demand now is not for just one gigabit per second, not 10 gigabits per second, but tens if not hundreds of gigabits per second. And it’s growing exponentially. The only way to achieve that is by starting to use optical communications or laser communications to augment or to complement RF communications” (Barry Matsumori, CEO of BridgeComm, 2022) (52).

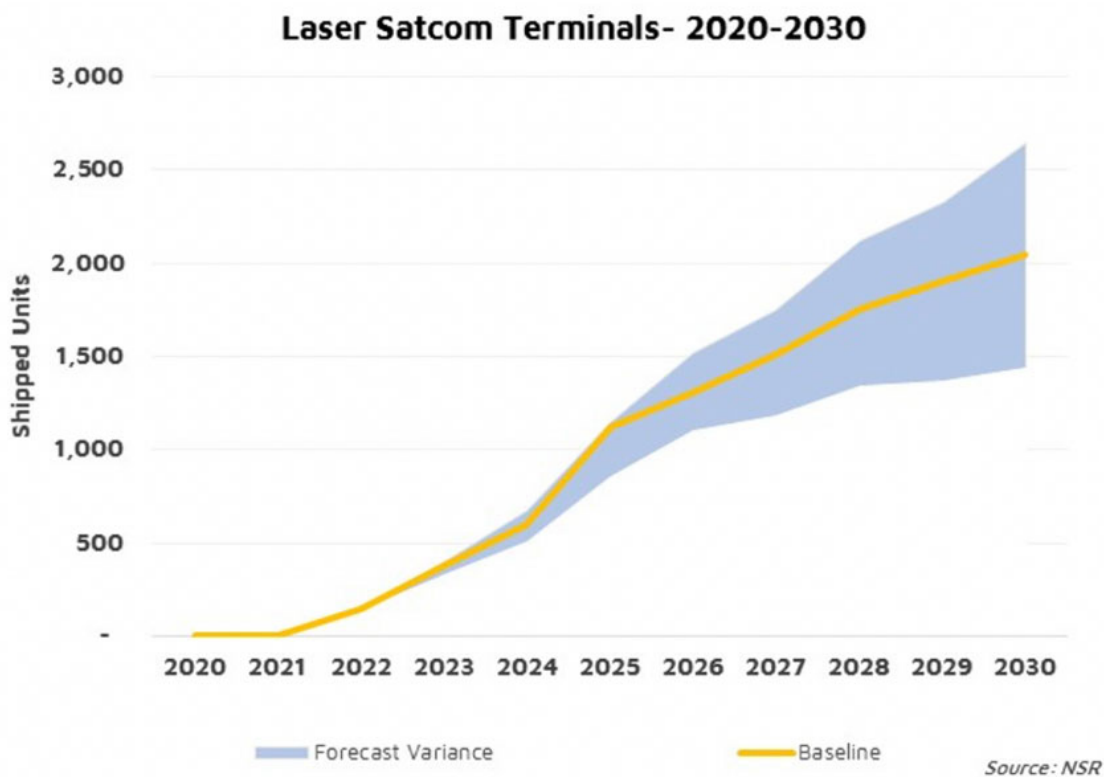


Figure 11.33: Laser terminals future forecast. Credit: Northern Sky Research.

### 11.10.2 Optical Ground Stations and Future Infrastructure Requirements

OGS contain notably different equipment than RF stations, including an optics assembly, photon counter assembly (usually involving a photon counting nanowire detector and cryostat), and signal processing assembly with a time-to-digital converter. Since optical communications use a frequency higher than RF, (e.g., 1,550 nm downlink and 1,065 nm uplink wavelengths), the optical dishes can be smaller than RF antennas. To receive optical signals from a low-Earth orbit, 40 – 60 cm telescopes are sufficient. For successful deep space optical communications, calculations show that 3 m, 4 m, or even 8 m diameter ground apertures are required, depending on the distance from Earth. For these size apertures, when a 3 – 8 m OGS is not available, partnerships can be formed with large astronomy telescopes. For example, JPL-designed OGS equipment has

been integrated at the Palomar Observatory (Hale 5-m telescope) for future use by the Deep Space Optical Communications (DSOC) demonstration. Note that OGS for LEO and deep space need different types of modems. It is also important for OGS to have spatial diversity. Weather, atmospheric conditions, turbulence, and aerosols in the air can degrade laser propagation. Because certain types and depth of cloud covers can cause signal loss, probability of link success increases with multiple diverse locations.

For interoperability between SmallSats and public and private optical ground stations, a common communications standard is key. The Consultative Committee for Space Data Systems (CCSDS) and Space Development Agency (SDA) provide recommendations for communications standards, including optical communications. Adhering to these standards by both SmallSats and ground stations allows for multi-mission optical ground stations.

JPL is operating the Optical Communications Telescope Laboratory (OCTL) at Table Mountain, CA, with a 1 m telescope, as shown in figure 11.34. This dish was used for the LADEE mission and offered great performance from a lunar distance (53).



*Figure 11.34: JPL's OCTL showing a 1-meter optical aperture. Credit: NASA JPL.*

JPL most notably operates the Deep Space Network (DSN), supporting 2-way RF communications and ranging services. Given the existing infrastructure, it is advantageous to augment a DSN RF antenna by installing optical segments at its center, making it a dual-purpose, RF-Optical hybrid antenna. The installation is being implemented in two phases.

In 2022 a small prototype RF-Optical system, including the mirror, cameras, and backend has been installed into DSS-13 (figure 11.35) at the Goldstone Deep Space Communications Complex. DSS-13 is the R&D 34 m BWG antenna at Goldstone. The combination of seven small (0.5m) mirrors comprises a synthesized prototype optical aperture of about 1.3 m diameter. As of 2022, the seven-segment prototype mirror system has been undergoing alignment, test, and checkout. Control was verified to maintain segment position to <1 microradian, with first light successfully received from natural light sources. 1550 nm light was measured through the 100-meter fiber at the pedestal. JPL was able to track multiple sources across the sky from 20-80 degrees elevation.



*Figure 11.35: JPL's DSS-13, a 34m RF antenna, showing a 1.3-meter optical aperture in its center. Credit: NASA JPL.*

A JPL designed communications detector and optical receiver been installed and tested over the air on DSS-13 as well. Other demo opportunities which could occur during the wait for Psyche (launch now delayed until next year) are being investigated.

The operational RF-Optical hybrid will ultimately include 64 mirrors each of 1m diameter, installed as a segmented 8 m optical receive aperture/mirror physically inside one of the new DSN 34 m



radio frequency ground terminals (DSS-23, in California). The final phase includes completion of the full 64-segment aperture on DSS-23, as illustrated in figure 11.36, including a full year of field tests. This 8 m equivalent optical ground aperture will be operational in the early 2030s.

DSS-23 will be capable of a full set of RF services with the 34 m antenna in addition to high-rate optical communications with its 8 m optical assembly. Before the full operational readiness dates for optical communications, the 1.3 m partial optical systems will be usable at various times for best effort demonstration optical communications passes in the near-Earth or Lunar regimes, as well as for deep space missions.

The DSS-23 optical receiver is the same design that JPL is delivering to the Palomar Observatory for use with the DSOC optical communications technology demonstration on the NASA Psyche mission. This receiver is also being installed in ground terminals at White Sands and other locations for other near- and deep-space missions, as well as Artemis. One exciting implication of this 8m equivalent optical aperture is that it meets the 230 Mbps downlink data rate requirement for human exploration of Mars.

Looking at the broader optical communications landscape, over the past decade the community has been confronted with a chicken and egg problem: due to the lack of a ground segment, the FSO space segment has been slow to develop, and additional investments have not been made due to the low number of satellites flying an FSO ground segment. Further, due to the experimental nature of the first flying optical payloads, there has not been sufficient operational budget to pay for optical ground station services. Nevertheless, optical downlinks have the potential to become an essential part of data downlinks, especially in the new-space domain (54).

## Europe

The European Optical Nucleus Network was formed between ESA ESOC, Germany Aerospace Centre (DLR), Global Security Operations Center (GSOC) and KSAT. Parties agreed to have an interoperable multi-mission approach based on the Consultative Committee for Space Data Systems (CCSDS) standards. Starting locations and characteristics are summarized in table 11-16. The Nemea OGS (figure 11.37) was operational as of 2022 after initial investments in the first commercial OGS, with the other stations soon to follow. The goal is to bring all building blocks together into an automated, cost-efficient, operational, multi-mission optical ground station service. This groundbreaking OGS uses modified COTS components to reduce cost, and could also be a blueprint for future stations. KSAT co-located its first OGS with KSAT RF antennas in the mid-latitudes at Nemea, due to the temperate weather and sharing the existing infrastructure. The OGS is compliant to the Optical On-Off Keying (CCSDS 141b1) draft standard and is designed to be cost competitive to the KSAT<sup>LITE</sup> service which KSAT is currently offering in the RF domain. The



*Figure 11.36: Artist overlay of built DSN RF antenna and planned 8m optical segments at its center. Credit: NASA.*



*Figure 11.37: KSAT's low-complexity optical ground station in Nemea (2021).*



telescope is mounted >3 m above the ground to avoid ground layer turbulence. The dome is a one-part, completely retractable structure with UV resistant plastic fabric. It is not connected to the telescope foundation to avoid coupling of vibrations caused by wind to the telescope system.

<b>Table 11-16: European Optical Nucleus Network OGS Key Parameters</b>			
	<b>Nemea</b>	<b>Almeria</b>	<b>Tenerife</b>
<b>Downlink wavelength support range</b>	1529-1569nm	1529-1569nm	1529.5-1568 nm
<b>Telescope main aperture diameter</b>	50 cm	60 cm	80 cm
<b>Elevation angle support range</b>	20° to 90°	10° to 85°	10° to 87° (LEO) 10° to 89° (GEO)
<b>Max. operation wind speed</b>	15 m/s (18 m/s gust)	15 m/s (18 m/s gust)	14m/s
<b>Operational min. sun-distance</b>	20°	20°	TBC
<b>Tracking modes</b>	Program-track Auto-track	Program-track Auto-track	Program-track Auto-track
<b>Temperature operational range</b>	-15°C to 40°C	-5°C to 35°C	TBC
<b>Acquisition Beacon Source</b>	1589.3nm, 5W (peak)	1589 – 1591nm, 5W (peak) TBC	1591.26 nm, 5 W 1590.4 nm, 8 W
<b>Acquisition beacon divergence angle (1/e<sup>2</sup> full-angle)</b>	632 μrad	1000 μrad TBC	500 μrad
<b>FoV of auto-track system</b>	8.5x6.8 arcmin	15x12 arcmin TBC	8.6 arcmin (diameter)
<b>Absolute pointing error*</b>	< 5 arcsec	< 10 arcsec	< +/- 103 arcsec (99% confidence)
<b>Auto-track accuracy</b>	1 arcsec RMS max. error 3 arcsec	1 arcsec RMS	0.41 arcsec RMS
<b>Site (mean) clear-sky probability</b>	Summer: 80-95% Winter <60%	Summer: >75% Winter: >55%	81%
<b>Site long term average seeing</b>	Day: 2.7 arcsec Night: 3.6 arcsec	TBD	Day: 2.2 arcsec Night: 1.8 arcsec
<b>Site WAN connectivity</b>	10 Gbps	10 Gbps	10 Gbps
<b>Location coordinates</b>	Lat. 37°50'42.5"N Long. 22°37'24.0"E 278.7 m above sea level	Lat. 37°5'36.3"N Long. 2°21'31,1"W 498 m above sea level	Lat. 28°17'58.7"N Long 16°30'38.5"W 2382 m above sea level

- KSAT co-located its first OGS with KSAT RF antennas in the mid-latitudes at Nemea, due to the temperate weather and sharing the existing infrastructure,
- The OGS is compliant to the Optical On-Off Keying (CCSDS 141b1) draft standard and is designed to become cost competitive to the KSAT<sup>LITE</sup> service, which KSAT currently offers in the RF domain.



- The goal was to bring all building blocks together into an automated, cost-efficient, operational, multi-mission optical ground station service.
- For cost reduction modified COTS components have been selected.
- The telescope is mounted more than three meters above the ground to avoid ground layer turbulence.
- The dome is a one-part completely retractable structure with UV resistant plastic fabric. It is not connected to the telescope foundation to avoid coupling of vibrations caused by wind to the telescope system.

The First Data Link Between Commercial Optical Terminals has been validated through a temporary Sony optical terminal placed on the ISS, with a channel data-rate of 150 Mbit/s with BER varying from  $1e-3$  and  $<1e-6$ .

### Japan

The National Institute of Information and Communications Technology (NICT) optical ground station in Japan also received transmission from the SOLISS system by Sony CSL installed on the Kibo's exposed facility on the ISS (55). In 2021 NICT also reported that the 1 m optical ground station in Koganei, Tokyo received via optical communication images taken by the satellite's camera the using the SOTA optical communications device mounted on a 50 kg class microsatellite.

### Germany

The DLR German Aerospace Center is another organization active in optical communications. About 25 km west of Munich, Germany is their Optical Ground Station Oberpfaffenhofen (OGS-OP) that houses a 40 cm Cassegrain telescope (56). The German Aerospace Center has also developed a transportable optical ground station (TOGS). It has a 60 cm deployable telescope in a Ritchey- Chretien-Cassegrain configuration with a focal ratio of  $f/2.5$ . The telescope is supported by an altazimuth mount on a structure with four adjustable legs for leveling the mount and compensating for rough terrain. It has been successfully used to track the OPALS instrument on the ISS and serves as the primary ground station for the OSIRIS payload on the BiROS satellite. The German Aerospace Center OGS-OP and TOGS are shown in figure 11.38.

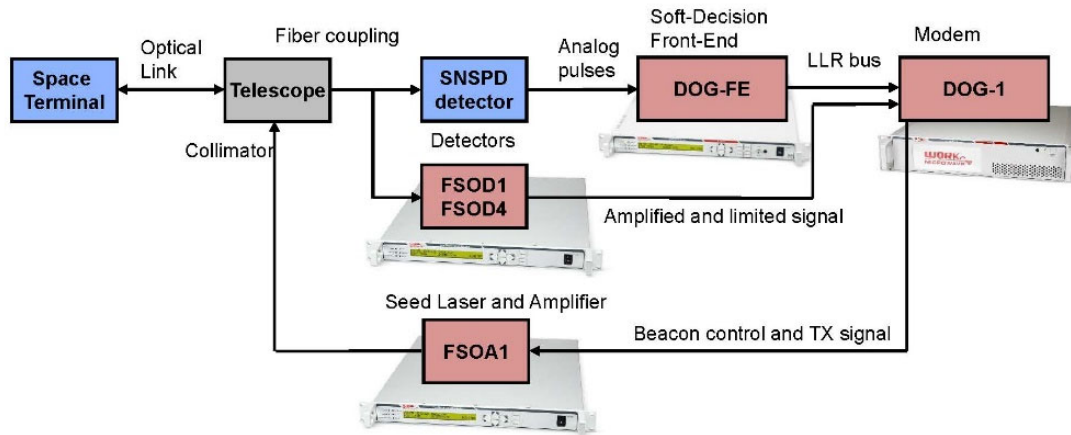


Figure 11.38: (left) OGS-OP and (right) TOGS. Credit: German Aerospace Center. <https://creativecommons.org/licenses/by/3.0/de/legalcode>.

WORK Microwave is a supplier for Optical Ground Stations (such as the one at Nemea), that also offers integration services for Ground Segment providers such as KSAT to develop OGS upon request. A soft quote for turn-key sub-1 meter OGS is ~ \$4 million (in 2022). Figure 11.39 reflects components available through WORK Microwave, while the balance of parts are sourced from

trusted partners. Two meter+ telescopes are also available. Two meter+ telescopes are also available. More info on [www.optical-ground-station.com](http://www.optical-ground-station.com).

## Space-to-Earth Communication Chain



Copyright ©2022 WORK Microwave GmbH

2

Figure 11.39: Optical Communications GS Space-to-Earth Communication Chain ([www.optical-ground-station.com](http://www.optical-ground-station.com)). Credit: WORK Microwave Inc.

### Australia – New Zealand

The Australian Optical Ground Station Network (AOGSN) will eventually be made up of four ground stations in Western Australia, South Australia, the Australian National University (Australian Capital Territory), and New Zealand. The plan is to tie these stations together to produce a communication network that can support optical, RF, and future quantum communications. In spring 2021, Thales Australia signed a research extension with SmartSat Cooperative Centre (CRC) for the development of advanced optical communications technologies (57).

Sascha Schediwy, head of the research group responsible for designing and building the WA Optical Ground Station (figure 11.40), believes lasers will play a crucial role in the next human missions to the Moon. "It's likely to be how we'll see high-definition footage of the first woman to walk on the Moon," Dr Schediwy said ([abc.net.au](http://abc.net.au)).

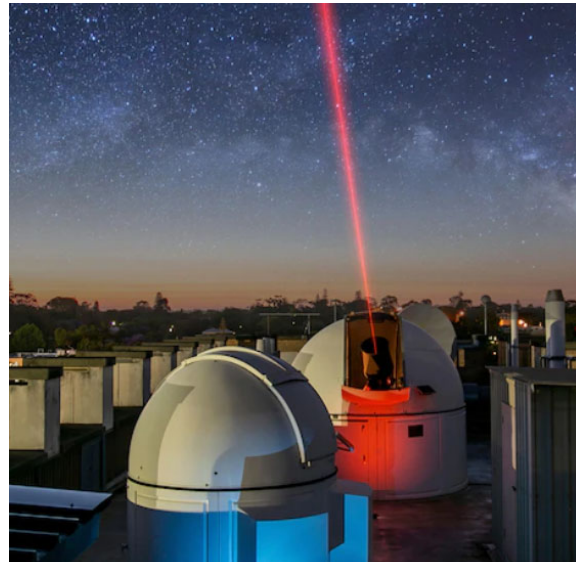


Figure 11.40: The 70 cm Western Australian Optical Ground Station (WAOGS) is installed on a rooftop at the University of Western Australia. Credit: The International Centre for Radio Astronomy Research.

## United States

In the U.S. the Aerospace Corporation is a player in the Optical Communication arena. Their manned OGS 40 cm telescope, located in El Segundo, CA, demonstrated 200 Mbps from 725 km. It is operating at 1064 nm wavelength, thus it is not compatible with other optical ground stations or most COTS optical space terminals.

### 11.10.3 Techniques to Improve Optical Comm Reliability

Laser communication is essential for future telecom networks to supplement RF communications and enable:

- Very high throughput links (> 10 Gb/s and up to Tb/s)
- Communication without frequency band limitation
- Highly secure, stealthy, non-interceptable links

It is essential for operational use cases:

- Multispectral observation of Earth from space (very bandwidth intensive)
- Securing sovereign communication
- Telecommunication constellations that rely on very broad bandwidth links

## Caillabs

Caillabs has developed a unique range of beam shaping products to counter the effects of atmospheric turbulence (see <https://www.caillabs.com/en/>). The company has used this technology to develop turnkey laser communication solutions, from single components to the entire station. Based on Caillabs' Multi-Plane Light Conversion (MPLC) technology, TILBA-ATMO compensates for atmospheric turbulence, improving free-space optical links. TILBA-ATMO is an easy-to-integrate product that takes a perturbed beam, corrects it and couples it into a standard single-mode fiber (figure 11.41). TILBA-ATMO makes it possible to use conventional telecom equipment and direct or coherent modulation formats to provide robust high throughput links to optical ground stations. In an open-air trial with DLR, link stability with TILBA-ATMO was similar

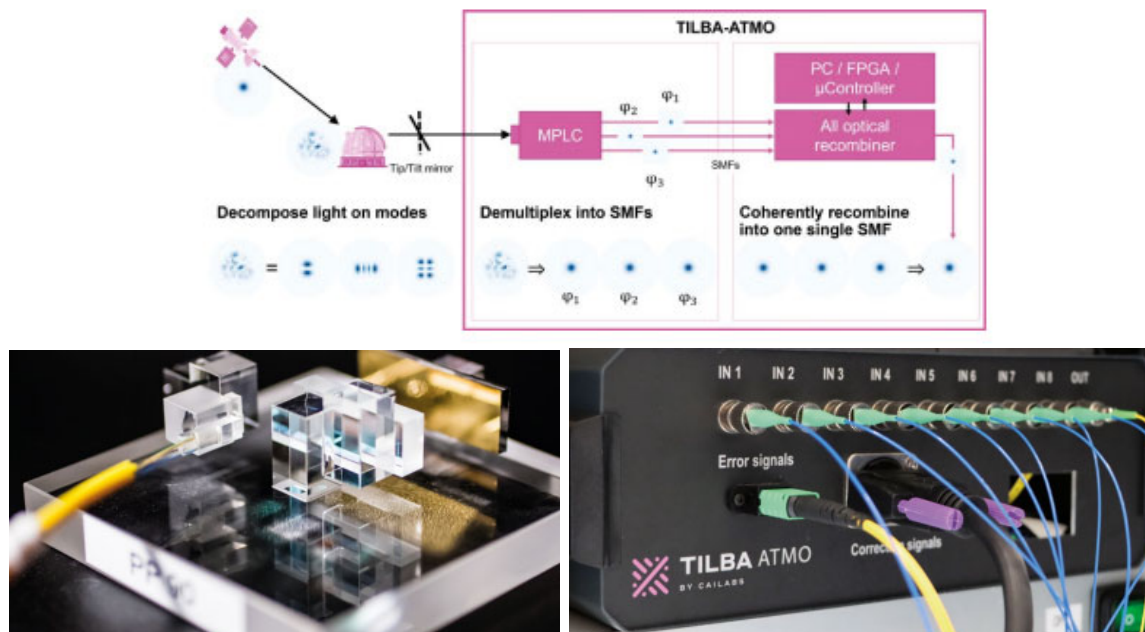


Figure 11.41: Caillabs Tilba Atmo equipment. Credit: Caillabs.

to that of the adaptive optics unit in low and medium turbulence, and more effective in strong scintillation conditions.

#### 11.10.4 Role of Optical Relays

Optical inter-satellite links are “critical to the success of the Space Development Agency’s low Earth orbit constellation” known as Transport Layer. SDA-Funded Laser Terminal Technology could connect to multiple satellites simultaneously. Each satellite in the Pentagon’s “planned mesh network of communications satellites could have as many as four laser links so they can talk to other satellites, airplanes, ships and ground stations.” BridgeComm, which recently received an SDA contract, “developed a so-called ‘one-to-many’ optical communications technology for point-to-multipoint transmissions” which could “help reduce the cost of building constellations by requiring fewer terminals,” Michael Abad-Santos, senior vice president of business development and strategy at BridgeComm] said. BridgeComm first demonstrated “point to multipoint optical communications in 2019 in a project with Boeing, and has since continued to mature the technology,” Abad-Santos said (58).

WarpSpace is a private Japanese company developing an inter-satellite communication system based on laser communication (figure 11.42). The WarpHub InterSat link relays will enable low latency data delivery from Leo and GEO orbits, and later on will connect to the Lunar Gateway or planetary deep space via optical communications (see <https://warpspace.jp/>).

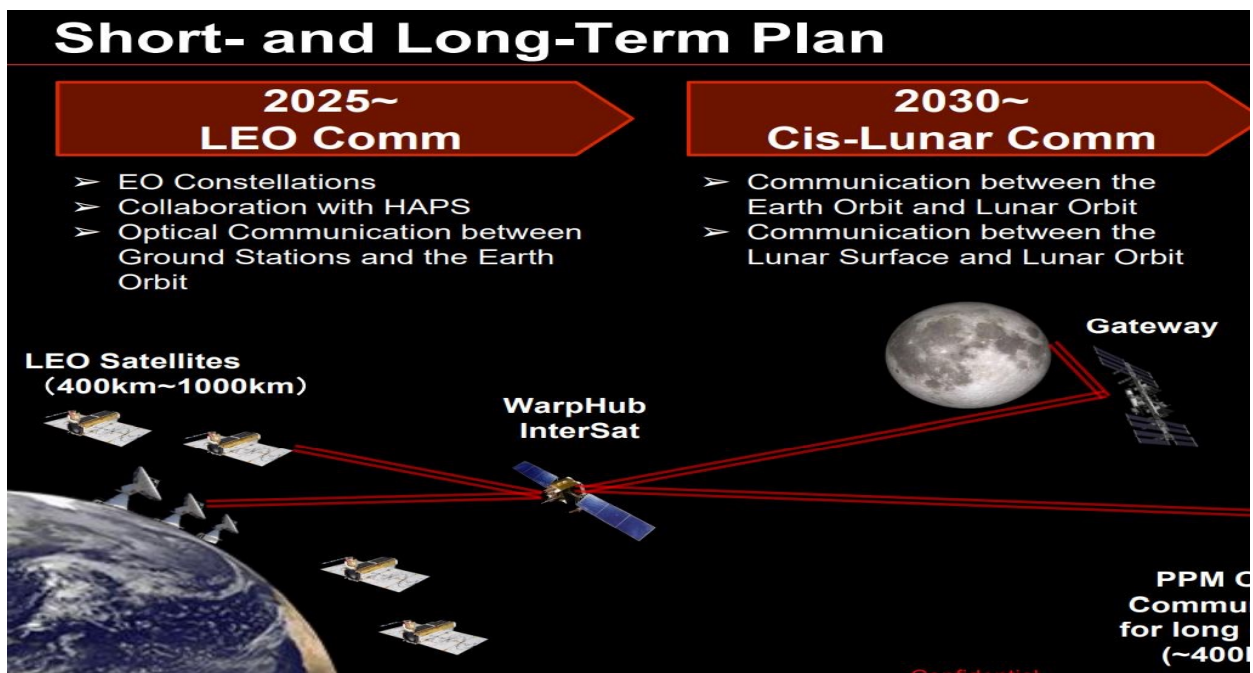


Figure 11.42: WarpSpace plans a satellite network in MEO orbit by 2025 with optical communications hardware able to be reached by any LEO satellite by 2025. Credit: WarpSpace.

### 11.11 Summary

The ground segment serves as the gateway to getting valuable data collected by the satellite into the hands of the user. It is a critical component of the satellite system that requires attention at the earliest stages of mission planning. Understanding what ground solution best meets the needs of the mission has a direct impact on the spacecraft design, concept of operations, launch schedule, mission operations cost, and expected data volume for processing. Much effort also goes into preparing for the interaction between the satellite and ground network. Developing



software and simulations, drafting operations manuals, conducting operations rehearsals, and performing compatibility tests are all par for the course. Post launch, the ground station also plays a key role in locating and commissioning the spacecraft.

In looking forward to the future of ground systems, the clear objective is how to bring the data down more efficiently. Great strides are being made with optical communications where it is possible to have increases in data per pass that are orders of magnitude above what can be achieved with RF communications. Optical communication technology is now being infused into ground system architectures, and flight hardware is becoming miniaturized enough to fit within small satellites. The ability of these systems to quickly change beam directions and acquire multiple targets will be critical for communicating with constellations of small satellites.

While the tried and true RF ground system solution remains the workhorse for small satellites, the innovative nature of the small satellite platform will soon challenge the community to adapt to systems capable of handling hundreds of satellites and high data volumes. Efforts are ongoing to keep pace, but only time will tell whether ground systems will advance or impede the small satellite revolution.

For feedback solicitation, please e-mail: [arc-sst-soa@mail.nasa.gov](mailto:arc-sst-soa@mail.nasa.gov). Please include a business e-mail so someone may contact you further.

## References

- (1) NASA. "NSN Brochure." [Online] 2021. Accessed July 2022. Available at: [https://explorers.larc.nasa.gov/2023APPROBE/pdf\\_files/Prog05e.%20NSN%20Brochure.pdf](https://explorers.larc.nasa.gov/2023APPROBE/pdf_files/Prog05e.%20NSN%20Brochure.pdf)
- (2) NASA. "Space Communications and Navigation," [Online] 2021 Accessed July 2022. Available at: [https://www.nasa.gov/directorates/heo/scan/services/networks/near\\_space\\_network](https://www.nasa.gov/directorates/heo/scan/services/networks/near_space_network)
- (3) KSAT, "KSATLITE," [Online] Accessed July 2022. Available at: <https://www.ksat.no/ground-network-services/ksatlite/>.
- (4) KSAT: Kongsberg Satellite Services: "Optical Communications: ESA-ESOC Optical Nucleus Network for Direct-to-Earth communications services up to Lunar distances." [Online] [Cited July 30, 2021]. <https://www.ksat.no/ground-network-services/new-technologies/optical-comms/>
- (5) Uppal, Rajesh. "Satellite Ground Segment as a Service (GSaaS) driven by New Space requirements," [Online] Accessed July 2022. Available at: <https://idstch.com/space/satellite-ground-segment-as-a-service-gsaas-driven-by-new-space-requirements/>
- (6) Nguyen, Louis. "Ground Stations as a Service (GSaaS) for Near Real-time Direct Broadcast Earth Science Satellite Data," [Online] Accessed June 2021. Available at: [https://esto.nasa.gov/forums/estf2021/Presentations/June10/Nguyen\\_GSON\\_ESTF2021.pdf](https://esto.nasa.gov/forums/estf2021/Presentations/June10/Nguyen_GSON_ESTF2021.pdf)
- (7) Amazon. AWS Ground Station Features. AWS. [Online] 2020. Accessed 2022. Available at: <https://aws.amazon.com/ground-station/features/>.
- (8) Viasat, "Real-time Earth Rethinking ground segment as a service" [Online] Accessed July 2022. Available at: <https://www.viasat.com/content/dam/us-site/antenna-systems/documents/viasat-real-time-earth-brochure.pdf>
- (9) R. O'Dwyer. "Iridium 88kbps service commercially available," [Online] November 11, 2021. Accessed July 2022. Available at: <https://smartmaritimetwork.com/2021/11/11/iridium-88kbps-service-commercially-available/>



- (10) D. Werner. "Analytical Space wins \$26.4 million to establish optical network," [Online] February 10, 2021. Accessed: July 2022. Available at: <https://spacenews.com/analytical-space-wins-26-4-million-to-establish-optical-network/>
- (11) Safran Data Systems. "Cortex HDR, High Data Rate Receiver for Space Science and Earth Observation," [Online] Accessed July 2022. Available at: [https://www.safran-group.com/sites/default/files/2021-05/col000016.4.0\\_cortex\\_hdr\\_a4\\_2.pdf](https://www.safran-group.com/sites/default/files/2021-05/col000016.4.0_cortex_hdr_a4_2.pdf)
- (12) NI Ettus Research. "Products," [Online] Accessed July 2022. Available at: <https://www.ettus.com/product-categories/usrp-x-series/>
- (13) Kratos. "SpectralNet," [Online] Accessed July 2022. Available at: <https://www.kratosdefense.com/products/space/networks/network-devices/spectralnet>
- (14) Celestia STS. "TNO and Celestia STS sign agreement to commercialize Optical Modem." June 30, 2021. [Online] Accessed July 18, 2021. Available at: <https://celestia-sts.com/2021/tno-and-celestia-sts-sign-agreement-to-commercialise-optical-modem/>
- (15) Infinite Technologies Incorporated. "RADOMES FUNCTION" *Radomes & Composite Structures*, [Online] Accessed July 2022. Available at: <https://compositeradomes.com/radomes/what-is-a-radomes-function/>
- (16) Amergint Technologies. "softFEP Datasheet," [Online] Accessed July 2022. Available at: [https://www.amergint.com/wp-content/uploads/AMERGINT\\_Datasheet\\_Software\\_Front-End\\_Processor\\_V2-2.pdf](https://www.amergint.com/wp-content/uploads/AMERGINT_Datasheet_Software_Front-End_Processor_V2-2.pdf)
- (17) Kratos. "quantumFEP Datasheet." [Online] Accessed July 2022. Available at: <https://www.kratosdefense.com/-/media/k/pdf/s/sa/os-014-openspace-quantumfep.pdf>
- (18) Csete, Alexandru. "About Gpredict," [Online] October 2020. Accessed: July 2022. Available at: <http://gpredict.oz9aec.net/>
- (19) GNU Radio. GNU Radio Main Page. Wikipedia. [Online] March 5, 2022. Accessed July 2022. [https://wiki.gnuradio.org/index.php/Main\\_Page](https://wiki.gnuradio.org/index.php/Main_Page)
- (20) DeWitt, Henry. Satellite Ground Station Control. DeWitt & Associates. [Online] Accessed: July 2022. Available at: <http://www.dewitt-assoc.com/groundStation.html>
- (21) GAUSS SRL "Group of Astrodynamics for the Use of Space Systems (G.A.U.S.S. Srl): . Ground Station," [Online] 2022. Accessed July 2022. Available at: <https://www.gaussteam.com/services/ground-station/>
- (22) GAUSS SRL. GAUSS UHF Mini Ground Dongle Datasheet. [Online] Accessed July 2022. Available at: [https://www.gaussteam.com/wordpress/wp-content/uploads/2018/04/GAUSSRadio\\_Miniground\\_Datasheet.pdf](https://www.gaussteam.com/wordpress/wp-content/uploads/2018/04/GAUSSRadio_Miniground_Datasheet.pdf)
- (23) GAUSS Srl. "Ground Station & Software." [Online] Accessed July 2022. Available at: [https://www.gaussteam.com/wordpress/wp-content/uploads/2018/01/Flyer\\_GroundStation\\_Software\\_1.pdf](https://www.gaussteam.com/wordpress/wp-content/uploads/2018/01/Flyer_GroundStation_Software_1.pdf)
- (24) Innovative Solutions in Space. "Ground Stations," [Online] Accessed July 2022. Available at: <https://www.isispace.nl/products/ground-stations/>
- (25) GomSpace. "Ground Systems," [Online] Accessed July 2022. Available at: <https://gomspace.com/shop/subsystems/ground-systems/default.aspx>
- (26) GomSpace. "Hands-off Operations Platform (HOOP)," [Online] Accessed October 2022. Available at: <https://gomspace.com/hoop.aspx>
- (27) Surrey Satellite Technology Ltd. "Space Services," [Online] Accessed July 2022. Available at: <https://www.sstl.co.uk/what-we-do/space-services>
- (28) Kratos. "Quantum Radio," [Online] Accessed July 2022. Available at: <https://www.kratosdefense.com/products/space/satellites/ttc-devices-and-software/quantumradio>
- (29) Kratos. "Be Future-Ready to Manage Tomorrow's Space Ground Network," [Online] Accessed July 2022. Available at: <https://www.kratosdefense.com/systems-and-platforms/space-systems/dynamic-ground/architecture>
- (30) INCOSE - International Council on Systems Engineering: "Systems Security Engineering:





- Mission and Objectives.” [Online] Accessed July 12, 2021. Available at: <https://www.incose.org/incose-member-resources/working-groups/analytic/systems-security-engineering>
- (31) National Security and Defense: “Memorandum on Space Policy Directive-5—Cybersecurity Principles for Space Systems” [Online] September 4, 2020. Accessed July 12, 2021. Available at: <https://trumpwhitehouse.archives.gov/presidential-actions/memorandum-space-policy-directive-5-cybersecurity-principles-space-systems/>
- (32) NASA. “Space System Protection Standard” NASA-STD-1006 w/Change 1. [Online] October 29, 2019. Accessed July 12, 2021. Available at: <https://standards.nasa.gov/standard/nasa/nasa-std-1006-wchange-1>
- (33) NASA. “NASA’s Commercial Communications Services,” [Online] Accessed August 01, 2022. Available at: [https://www.nasa.gov/directorates/heo/scan/services/nasas\\_commercial\\_communications\\_services](https://www.nasa.gov/directorates/heo/scan/services/nasas_commercial_communications_services)
- (34) R. Ross (NIST), V. Pillitteri (NIST), R. Graubart (MITRE), D. Bodeau (MITRE), R. McQuaid (MITRE): “Developing Cyber Resilient Systems: A Systems Security Engineering Approach.” SP 800-160 Vol. 2. November 2019.
- (35) R. Ross (NIST), M. McEvilley (MITRE), J. Oren (Legg Mason). “Systems Security Engineering: Considerations for a Multidisciplinary Approach in the Engineering of Trustworthy Secure Systems. “ NIST SP 800-160 Vol. 1, November 2016 (Updated March 21, 2018). Accessed July 12, 2021. Available at: <https://csrc.nist.gov/publications/detail/sp/800-160/vol-1/final>
- (36) National Institute of Standards and Technology : “Cybersecurity Framework” [Online] Accessed July 12, 2021. Available at: <https://www.nist.gov/cyberframework>
- (37) The Aerospace Corporation: “Defending Spacecraft in the Cyber Domain.” [Online] [Cited July 30, 2021]. <https://aerospace.org/paper/defending-spacecraft-cyber-domain>
- (38) S. Visner and S. C. Kordella, The MITRE Corporation: “Cyber Best Practices for Small Satellites.” (November 2020). <https://www.mitre.org/publications/technical-papers/cyber-best-practices-for-small-satellites>
- (39) Consultative Committee for Space Data Systems: “Report Concerning Space Data System Standards.” CCSDS 350.7-G-2, Green Book, Issue 2. April 2019.
- (40) Consultative Committee for Space Data Systems: “Report on the Application of Security to CCSDS Protocols.” CCSDS 350.0-G-3, Green Book, Issue 3. March 2019.
- (41) G.P Bortoletto, D. Melli, F. Stigliano, D. Martin, F. Gardosi. “Maximize contact availability of smallsat clusters through MSPA technique on GSaaS,” Presented at SmallSat Conference, Logan, UT. 2021. Available at: <https://digitalcommons.usu.edu/smallsat/2021/all2021/44/>
- (42) Shannon Terry, A.I. Solutions, Inc. “What are Space Ground Systems?” [Online] Accessed July 2022. Available at: <https://ai-solutions.com/about-us/news-multimedia/what-are-space-ground-systems/>
- (43) R. Jewett, “Viasat Releases New Large-Aperture Space-to-Ground Communication Antennas,” ViaSatellite, January 20, 2022. [Online] Accessed July 2022. Available at: <https://www.satellitetoday.com/ground-systems/2022/01/20/viasat-releases-new-large-aperture-space-to-ground-communication-antennas/>
- (44) Sampathkumar, Arun Kumar. Uber-ization of Ground Stations. “The Small Satellite Market’s Enabling Aggregator Wave,” [Online]. Accessed September 23, 2022. Available at: <https://interactive.satellitetoday.com/via/august-2021/uber-ization-of->



- [ground-stations-the-small-satellite-markets-enabling-aggregator-wave/](#)
- (45) OpenC3, Inc. "Documentation," [Online] Accessed 2022. Available at: <https://openc3.com/docs/v5/>
- (46) The Hammers Company. Galaxy. [Online] Accessed 2020. Available at: <https://hammers.com/galaxy>
- (47) Xplore. Major Tom. [Online] Accessed July 2022. Available at: <https://www.xplore.com/services/operations-as-a-service/major-tom.html>
- (48) Orbit Logic. [Online] Accessed 2020. Available at: <https://www.orbitlogic.com/index.html>
- (49) Parsons. "Automated Command And Control For Smarter Space Operations," [Online] Accessed 2022. Available at: <https://www.parsons.com/products/ace-ctrlpoint/>
- (50) Bright Ascension. Mission Control Software. [Online] Accessed 2020. Available at: <https://www.brightascension.com/products/ground-control-software/>
- (51) NASA. July 15, 2018. "LLCD: 2013-2014," [Online] Accessed 2022. Available at: <https://www.nasa.gov/directorates/heo/scan/opticalcommunications/llcd/>
- (52) Waterman, S. "Space Lasers Come of Age: Optical Communications for Satellites Are Ready for Prime Time," [Online] February 22, 2022. Accessed July 2022. Available. [https://interactive.satellitetoday.com/via/march-2022/space-lasers-come-of-age-optical-communications-for-satellites-are-ready-for-prime-time/\\_fragment.html](https://interactive.satellitetoday.com/via/march-2022/space-lasers-come-of-age-optical-communications-for-satellites-are-ready-for-prime-time/_fragment.html)
- (53) NASA. Lunar Laser Communication Demonstration: NASA's First Space Laser Communication System Demonstration Fact Sheet," [Online] Accessed 2022. Available at: "[https://www.nasa.gov/sites/default/files/llcdfactsheet.final\\_web.pdf](https://www.nasa.gov/sites/default/files/llcdfactsheet.final_web.pdf)
- (54) Krynitz, Martin and Heese, Clemens and Knopp, Marcus Thomas and Schulz, Klaus-Jürgen and Henniger, Hennes. "The European Optical Nucleus Network," 16th International Conference on Space Operations (SpaceOps 2021), 03.-05. May 2021.
- (55) National Institute of Information and Communications Technology (NICT). "Small Optical Link for International Space Station (SOLISS) Succeeds in Bidirectional Laser Communication Between Space and Ground Station," [Online] April 30, 2020. Accessed 2022. Available at: <https://www.nict.go.jp/en/press/2020/04/30-1.html>
- (56) Florian Moll, Amita Shrestha, Christian Fuchs. Ground stations for aeronautical and space laser communications at German Aerospace Center. Publisher: Proc. SPIE 9647, Advanced Free-Space Optical Communication Techniques and Applications. <https://core.ac.uk/reader/31021696>
- (57) Thales: "Beam me up! Thales & Goonhilly Earth Station collaborate on research into laser beams as data pipes." June 8, 2021. [Online]. Accessed July 23, 2021. Available at: <https://www.thalesgroup.com/en/australia/press-release/beam-me-thales-goonhilly-earth-station-collaborate-research-laser-beams>
- (58) S. Erwin. "DoD space agency funds development of laser terminal that connects to multiple satellites at once," [Online] March 10, 2022. Accessed July 23, 2021. Available at: <https://spacenews.com/dod-space-agency-funds-development-of-laser-terminal-that-connects-to-multiple-satellite-at-once/>
- (59) NASA. "NASA to Commercialize Near-Earth Communications Services," [Online] October 26, 2022. Accessed July 23, 2021. Available at: <https://www.nasa.gov/feature/Goddard/2020/nasa-to-commercialize-near-earth-communications-services>



## Chapter Contents

Glossary .....	ii
12.0 Identification and Tracking Systems .....	335
12.1 Introduction .....	335
12.2 Identification and Tracking Ground Systems.....	336
12.3 Tracking Aids .....	337
12.4 Devices that Communicate Position and ID via Radio .....	338
12.5 Devices that use Coded Light Signals.....	339
12.5.1 Van Atta Arrays and RF Interrogation Receivers.....	340
12.5.2 Laser-Interrogated Corner Cube Reflectors.....	341
12.5.3 Passive Increase in Albedo .....	342
12.6 Future Efforts .....	342
12.7 Summary.....	343
References.....	343



## Chapter Glossary

(18 SDS)	U.S. Space Force 18 <sup>th</sup> Space Defense Squadron
(19 SDS)	U.S. Space Force 19 <sup>th</sup> Space Defense Squadron
(AGI)	Analytical Graphics, Inc.
(CARA)	Conjunction Assessment Risk Analysis
(CCR)	Corner Cube Reflectors
(CNES)	French Space Agency
(COTS)	Commercial-off-the-Shelf
(CUBIT)	CubeSat Identification Tag
(D/T/I)	Detection, Tracking and Identification
(EGTN)	ExoAnalytic Global Telescope Network
(ELROI)	Extremely Low Resource Optical Identifier
(FCC)	Federal Communications Commission
(GEO)	Geosynchronous Equatorial Orbit
(GPS)	Global Positioning System
(GUI)	Graphical User Interface
(HEO)	Highly Elliptical Orbit
(HUSIR)	Haystack Ultrawideband Satellite Imaging Radar
(IDs)	Identification
(ILRS)	International Laser Ranging Service
(JSpOC)	Joint Space Operations Center
(LEDs)	Light Emitting Diodes
(MEO)	Medium Earth Orbit
(NID)	NASA Interim Directive
(NTE)	Nanosatellite Tracking Experiment
(NTIA)	National Telecommunications and Information Administration
(OCAP)	Orbital Conjunction Assessment Plan
(PNT)	Positioning, Navigation, and Timing
(RF)	Radio Frequency
(SRI)	Stanford Research Institute
(SSA)	Space Situational Awareness
(SSN)	Space Surveillance Network
(SWaP)	Size, Weight, and Power
(TLE)	Two-Line Element
(USIR)	Ultrawideband Satellite Imaging Radar



## 12.0 Identification and Tracking Systems

### 12.1 Introduction

In the past, most launches involved a single, large satellite launching on a dedicated launch vehicle. Small satellites as secondary payloads were sometimes ‘dropped off’ along the way to the primary payload’s orbit or rode along to the final orbit with the primary payload. In either case, it typically was not that difficult to distinguish between primary and secondary payloads via size and operational parameters.

Recently, however, multi-manifest or “rideshare” launches have become more common, and providers (1-3) are launching multiple CubeSats, or bundling CubeSats and other smaller payloads with larger payloads to fill up the excess capacity of almost any given launch vehicle. For technical and cost reasons, such launches generally deploy small satellites and CubeSats into very similar orbits over a short time window. “Batch” launches with a lack of separation between satellites can prevent effective tracking and create “CubeSat confusion” (4). When CubeSats are deployed close together in space and time they can be hard to distinguish from each other by tracking radars, making it difficult to determine which orbits correlate to which spacecraft, preventing a unique orbital state from being added to the catalog of on-orbit objects (5, 6). At times it can take weeks to months to sort out which object is which, while some may never be uniquely identified at all.

Due to their standardized shape and size, CubeSats look very similar to one another, especially when they are in orbit hundreds of kilometers away. If there are unidentified objects from a launch, then the possible number of associations of object identifications (IDs) to tracked objects scales as  $n!$  ( $n$ -factorial, where  $n$  is the number of unidentified space objects from the launch). For example, if there are just two objects, say a payload and an upper stage, there are two ways in which you can associate the IDs with the tracked objects, and even that can be a challenge (7). However, if there are ten unidentified objects, there are 3,628,800 possible combinations; with 20 this rises to  $2.4 \times 10^{18}$  combinations. The magnitude of the problem gets big quickly.

Small satellites can improve their chances of being identified and tracked through good coordination with tracking agencies pre-launch, through community sharing of Two-Line Element (TLE) sets and other position data in clearly defined, consistent, standard formats, and through careful selection of deployment direction and timing (8). Good design choices can also improve the chances of small satellites surviving launch and early orbit (9) and can even make use of in-space commercial radio networks as a “back-up” method of communicating should primary systems fail (10). However, despite improvements in both design and coordination, many small satellites still go unidentified. This has led to the introduction of tracking aids – independent systems that help owners and trackers identify small satellites and CubeSats, in some cases even if the satellite is malfunctioning.

The information described below is not intended to be exhaustive but provides an overview of current state-of-the-art technologies and their development status for a particular small spacecraft subsystem. It should be noted that Technology Readiness Level (TRL) designations may vary with changes specific to payload, mission requirements, reliability considerations, and/or the environment in which performance was demonstrated. Readers are highly encouraged to reach out to companies for further information regarding the performance and TRL of described technology. There is no intention of mentioning certain companies and omitting others based on their technologies or relationship with NASA.



## 12.2 Identification and Tracking Ground Systems

Initially established in 2005, the Joint Space Operations Center (JSpOC) was performing space surveillance and providing foundational Space Situational Awareness (SSA) for the US Department of Defense as well as for other agencies and space entities. Since July 2016, that role is provided by the 18<sup>th</sup> Space Defense Squadron (18 SDS), located at Vandenberg Space Force Base in California, which assumed all catalog maintenance functions including detection, tracking and identification (D/T/I) of artificial objects in Earth orbit and maintaining the space catalog which is publicly available on [space-track.org](http://space-track.org). As part of their activities, they provide launch support, re-entry assessment, and other SSA functions; orbital safety activities, such as conjunction assessment (which identifies close approaches between launch and other catalogued in-orbit objects) are provided by the 19<sup>th</sup> Space Defense Squadron (19 SDS), located at the Naval Support Facility at Dahlgren, VA. Maintaining the catalog is achieved via the US Space Surveillance Network (SSN) that is formed by a suite of sensors around the world (29). 18 SDS is currently tracking more than 45,000 objects in Earth orbit and can provide data for pieces as small as 10 cm<sup>3</sup>. They issue TLEs that are updated on a regular basis and can be used to compute predicted orbit position for spacecraft communications acquisition and other purposes. They also produce precision vectors with covariance that can be used to perform conjunction analyses.

The US Air Force next generation SSA sensor, known as the Space Fence, was declared operational in March 2020 and can track objects below the previous 10 cm<sup>3</sup> limit. It is located on Kwajalein Island, in the Republic of the Marshall Islands and consists of a S-band radar system to track objects primarily in low-Earth orbit, although it can track objects in medium-Earth orbit (MEO) and geostationary equatorial orbit (GEO) as well. The 20<sup>th</sup> Space Control Squadron based in Huntsville, Alabama, manages the Space Fence and provides data to the 18 SDS to augment the space catalogue (30). Another major antenna in the SSN is the Haystack Ultrawideband Satellite Imaging Radar (HUSIR), which is the highest-resolution, long-range sensor in the world. HUSIR simultaneously generates X- and W-band images that can provide valuable information about the size, shape and orientation of Earth orbiting objects (31). These are just several examples of sensors that make up the SSN, many having specific unique capabilities that support the SSN's various functions, including conjunction assessment.

The NASA Conjunction Assessment Risk Analysis (CARA) program acts as an important intermediary between 18/19 SDS and NASA satellite missions. CARA usually gathers daily orbit ephemeris and covariance files from the spacecraft operations teams and provides this data to 18/19 SDS for screening and close approach prediction. CARA provides risk assessment of these predicted close approaches to NASA missions beyond the 19 SDS support provided to non-NASA users, including operations concept development, probability of collision computation, high interest event notification, and conjunction geometry analysis among other functions. In 2012, the French Space Agency (CNES) created a conjunction risk assessment team called CAESAR that provides risk assessment services to their missions (34) (35).

NASA recently released a best practices handbook entitled "Spacecraft Conjunction Assessment and Collision Avoidance Best Practices Handbook," which is a great reference for satellite operators with respect to collision avoidance topics (32). The NASA Interim Directive (NID) provides information on the minimum collision avoidance requirements and associated operational protocols for NASA space flight programs, projects, and vehicles to protect the space environment and reduce the risk of collision (33).

Besides government assets, several commercial entities are providing tracking capabilities that can be purchased by stakeholders. These include Analytical Graphics, Inc. (AGI) which provides data from a network of commercial sensors through its Commercial Space Operations Center. ExoAnalytic also has a global telescope network (EGTN) consisting of over 25 observatories and



275 telescopes tracking orbiting objects in GEO, highly elliptical orbit (HEO), and MEO. The EGTN can collect angles and brightness measurements. They maintain a proprietary catalog of satellites and space debris that are regularly tracked and cataloged. This includes a historical archive of over 100 million object measurements (26).

LeoLabs is another commercial entity providing detailed information for spacecraft tracking. They use a group of distributed Earth-based, phased-array radars to make a commercial-off-the-shelf (COTS) satellite tracking service targeted to the specific requirements of SmallSat operators in low-Earth orbit. They currently have two radar stations in the United States and radar sites in New Zealand, Costa Rica, and the Azores. There are currently four functioning radars as of 2022, with plans for six radars strategically located around the world to robustly track objects down to 2 cm in size. The predicted performance also includes a revisit time of over 10 observations per day for specific objects, and a low-Earth orbit catalog of over 250,000 pieces. Through their LeoTrack platform, they can use their radar data to perform precision tracking and curate orbit information products for satellites as small as 1U. Their system includes an open-source graphical user interface (GUI) capable of displaying all the catalog in real time, as well as fundamental orbit information about each individual object. They recently announced a commercial launch and early orbit service, with SpaceX as their initial customer (39).

Catalogs provided by these commercial entities are different from the one maintained by 18 SDS in accuracy and objects included. Spacecraft owner/operators should be aware of the differences before choosing to use a particular service for a particular purpose. For conjunction assessment purposes, having multiple differing solutions can be confusing when attempting to make a decision. The Department of Commerce was charged in Space Policy Directive-3 with creating a space traffic coordination system that enables commercial capabilities for conjunction assessment. In the future they may offer a conjunction assessment service that merges data from multiple sources in one solution as they work to transition the service currently provided by 19 SDS.

### **12.3 Tracking Aids**

For spacecraft that cannot be routinely tracked by the SSN, it is important to ensure trackability by another means to enable other owner/operators to know where your spacecraft is to prevent debris-producing collisions. This is especially important for SmallSats that have orbital lifetimes that exceed operational lifetimes, and the risk to orbital neighbors remains after tracking activities have stopped. For NASA spacecraft, trackability is assessed as part of the Orbital Conjunction Assessment Plan (OCAP) required during design by NID 7120.132.

Tracking aids come in several categories, each with benefits and drawbacks (11). Table 12-1 discusses the broad categories available, with representative examples discussed below. Size, weight, and cost vary for each of the examples, but all can be considered compatible with a CubeSat mission; see the references for detailed information on size, weight, and power (SWaP) and cost. Once the augmented tracking is collected, ephemeris data would be produced and made available to CARA/19 SDS for screening.

Table 12-1: Types of Tracking Aids			
Technology scheme	Description and reference mission	TRL	Citation
CubeSat position and ID via radio	A position, navigation, and timing (PNT) receiver is attached to a CubeSat, along with a radio to transmit the information via a LEO communications provider (or directly to the ground); example: BlackBox, Blinker.	7-9	(12) (13)
Coded light signals from light source on exterior of CubeSat	Exterior-mounted LEDs with large-aperture telescopes to receive the signal or diffused LED lasers with ground-based photon-counting cameras.	6-7	(14) (15)
Radio Frequency interrogation of an exterior Van Atta array	For example, exterior mounted radio frequency identification (RFID) tag & commensurate radar.	7-9	(16)
Laser interrogated corner cube reflectors (CCR)	One or several small CCRs can be attached to CubeSat exterior; ground-based laser and receiver telescope needed to distinguish number of CCRs.	7-9	(17)
Passive augmentations to visibility	Use of high-albedo paint or tape, improving overall conductance of the exterior of the satellite or other methods to increase visibility.	7-9	

## 12.4 Devices that Communicate Position and ID via Radio

The most comprehensive (but also potentially the most complex and SWaP-intensive) option involves equipping a small satellite with an independent positioning, navigation, and timing (PNT) receiver and independent radio capable of transmitting data to an independent communications provider. An example technology is the Black Box system (figure 12.1), described by NearSpace Launch, Inc., in a recent conference paper (18). This system comes in several form factors for mounting internally or externally to a small satellite or CubeSat. The patch antenna shown in the first image is approximately 10 cm by 8 cm and can weigh as little as 22 grams; larger systems

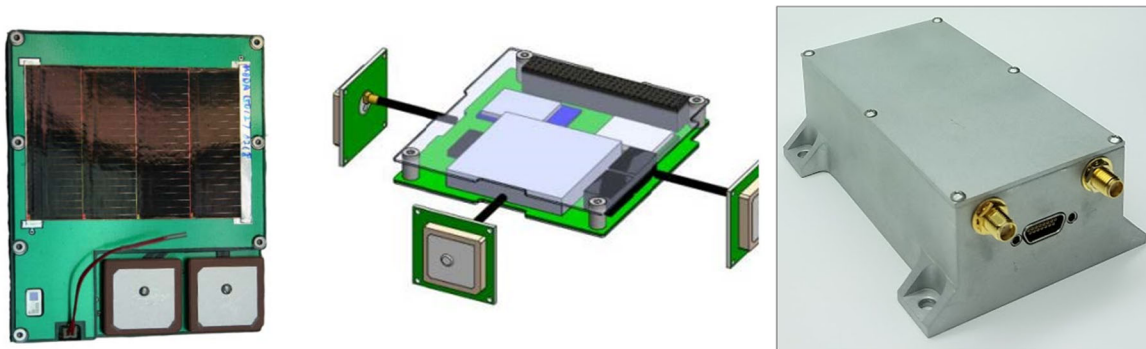


Figure 12.1: (left) Thin Patch or Stamp Black Box for side mounting. (Middle) PC104 Black Box for internal stack mounting. (Right) Standard Black Box for larger satellites. TRL 9: flown on spaceflight launch. Solar array and antennas not shown. Credit: NearSpace Launch, Inc.





such as the one shown in the third image of figure 12.1 have flown and are considered TRL 9. These systems combine a low-power GPS receiver with a low-power radio capable of communicating with a low-Earth orbit communication provider (in the case of Black Box, the Global Star network) and operate independently from the spacecraft's regular command and telemetry links. Externally mounted versions often include solar cells for independent power generation. A Black Box system is currently flying on Spaceflight Sherpa-FX orbital transfer vehicle, launched on January 24, 2021, and is returning GPS fixes to the developer. The GPS fixes were analyzed and reports were presented at the October 2021 and October 2022 International Astronautical Congress (41, 42).

A similar concept under development is The Aerospace Corporation's 'Blinker' (13), in which a GPS receiver and low-power radio are externally mounted to a CubeSat. GPS positions ("tags") are recorded, stored, and then radioed when the satellite is over an Aerospace Corporation ground station (which is separate and independent from the CubeSat's mission ground station). Research and development are being conducted to automatically convert the GPS tags into ephemeris information that can be directly ingested by space situational awareness centers (in this case the 18 SDS via Space-Track.org) as an owner/operator initial ephemeris that would be propagated by 19 SDS and screened for conjunction assessment.

The advantages to such a system are that it provides complete data on a satellite's position and requires no specialized ground equipment (other than the equipment used by the communications provider). Some such systems are independently powered and can provide data even if the host satellite never powers up, though others are dependent on spacecraft power to function. These systems are the most complex of the tracking aids described, however, and despite their relatively small size, are still the most SWaP-intensive of the options examined. Systems that rely on power from the host vehicle are also useless if the host vehicle suffers a power anomaly or failure. Having an additional onboard radio that communicates with other space assets necessitates additional oversight by the Federal Communications Commission (FCC) (or National Telecommunications and Information Administration (NTIA) for US Government missions licensing and coordination).

## 12.5 Devices that use Coded Light Signals

Identification systems and devices that make use of light emitting diodes (LEDs) and coded light signals have the advantage of being relatively simple and capable of identifying satellites uniquely. However, all systems flown to date have required power from the host satellite, leading to issues with detection (19) if the host satellite does not power up. Current implementations are also relatively large, though future systems are expected to be much smaller and may include independent power. Devices such as the Extremely Low Resource Optical Identifier (ELROI) beacon (figure 12.2), under development by Los Alamos National Lab (19), use exterior-mounted LEDs or diode lasers that blink in a prescribed sequence to uniquely identify satellites. The ELROI system is designed to be independently powered by a small solar cell and battery, and is packaged into a system as small as a Scrabble tile, though only larger systems – with power provided by the host satellite – have flown.

The emitters on such devices can be regular LEDs or diffused diode lasers but require specialized ground equipment – either a large-aperture telescope or a photon-counting camera – to track the object as it passes overhead. Figure 12.3 shows how the ELROI system works: a photon-counting camera attached to a telescope tracks the signal from a diode laser and decodes the ID of the host satellite from the on/off pattern of flashes.

Another similar system (36) proposes to use red, blue, and green LED lights on specific faces of the satellite, which blink in a unique pattern, and standard astronomical optical telescopes to track and identify the LED flash pattern (14). LEDSAT, a CubeSat to test this concept on-orbit, launched

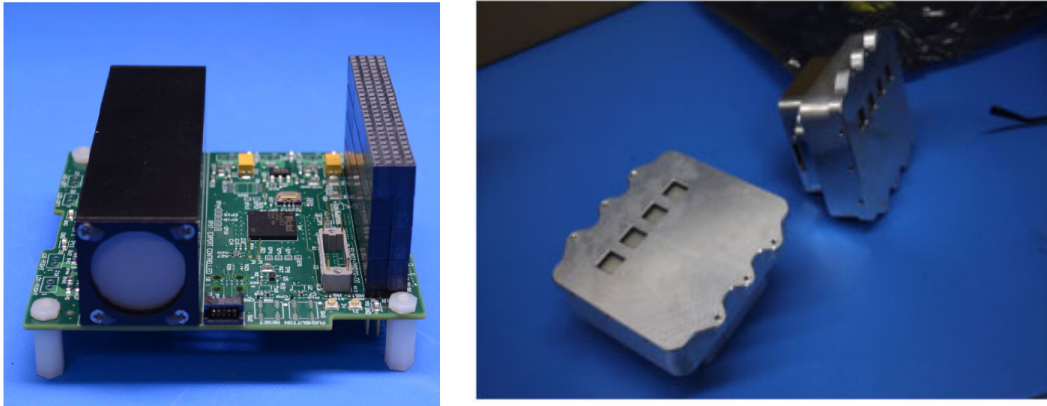


Figure 12.2: (left) ELROI PC104 beacon unit that was installed on NMTSat.d (right) Two ELROI beacon units delivered for a launch in 2021. Credit: Los Alamos National Laboratory.

in August 2021 (37). A test of an exterior-mounted blue LED on a CubeSat was attempted in March 2021, but was indeterminate due to a lengthy period of bad weather at the single designated telescope site.

LED-based systems require relatively clear night-time skies for identification, and dedicated ground equipment (telescope and sensor). The light sources are too faint to allow blind searching of the sky for the satellite; orbital information from a SSA provider is also required to find and track the CubeSat, although the process of tracking the satellite via an optical telescope allows the orbital ephemeris to be updated. Therefore this tracking enhancement alone cannot be used for identifying and cataloging the spacecraft. Issues with attitude control on the host satellite can also complicate the identification process. In addition, using LEDs or other light sources on a satellite while in Earth’s shadow should be done carefully to minimize interference with astronomical observations. The SatCon1 report (38) on page 6 lists several recommendations to be followed: 1) assure the light source is fainter than apparent magnitude of  $V \sim 7$  (and the fainter the better), and 2) advance notice of any illumination times, including accurate orbital elements.

**12.5.1 Van Atta Arrays and RF Interrogation Receivers**

Another method for increasing the ability to track and possible identification of small satellites involves devices that respond when interrogated by a radio frequency (RF)

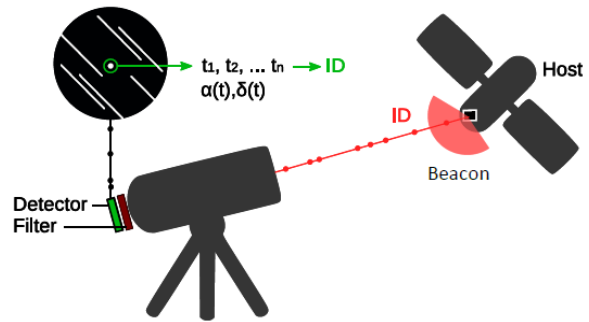
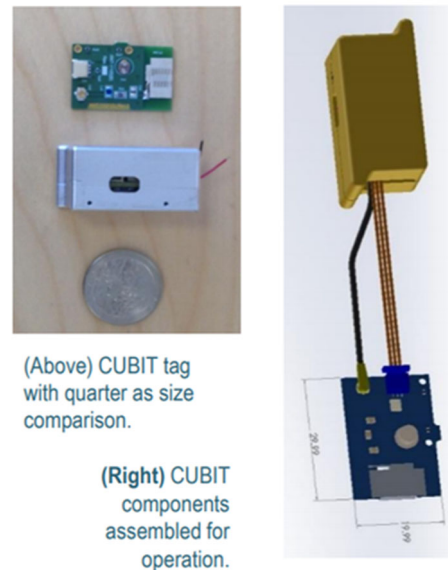


Figure 12.3: ELROI Optical Detection System. Credit: Los Alamos National Laboratory.



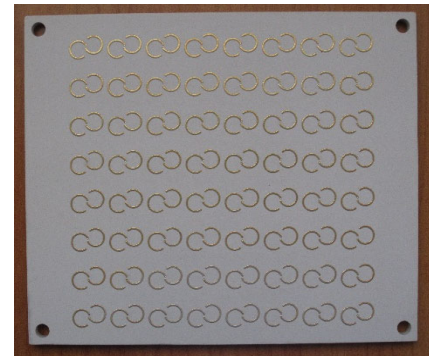
(Above) CUBIT tag with quarter as size comparison.

(Right) CUBIT components assembled for operation.

Figure 12.4: CUBIT. Credit: SRI International.

signal of appropriate wavelength. One such system, the CubeSat Identification Tag (CUBIT) shown in figure 12.4, is similar to the RFID devices used in proximity badges (16). Built by SRI International and partnered with NASA Ames, CUBIT responds with a short burst of information when interrogated by a radio signal of the correct frequency. CUBIT is relatively small and designed to be independent of host vehicle power. The implementations that have flown contain a small battery suitable for 30 days of in-orbit life, which covers the most critical early orbit identification period. It could therefore be coupled with a coded light emitter to overcome the inability of that system to allow object identification. The device is separated into an internally mounted electronics unit attached to an exterior antenna to minimize the exterior footprint of the unit. Two units have flown and were successfully demonstrated in space onboard TechEdSat-6 in 2017 and TechEdSat-7 in 2020. A relatively large ground architecture (in CUBIT's case, a 30 m antenna and an array of antennas) are required to interrogate the system and successfully acquire the low-power response. CUBIT is patent-pending, and SRI has reached commercialization agreements with potential vendors. Future research will continue with a recently awarded AFWERX Phase 1 study.

Another example of an RF-interrogated device is a Van Atta array, a passive device which re-radiates RF energy back toward the source of that energy (20). One such device, the Nanosatellite Tracking Experiment (NTE) consists of a 64-element Van Atta array of tiny, paired antennas tuned to a Ku-band RF frequency, as shown in figure 12.5 (21). When interrogated at the proper frequency range, the incident RF field received by each antenna is fed to a corresponding antenna via a passive transmission line, where it is re-radiated. This significantly increases the radar cross-section of the object, allowing it to be more easily tracked. Unique identification is difficult, however, and requires specialized ground stations which tend to be expensive to operate. A satellite carrying a Van Atta array device will be distinguishable from one not carrying such a device, or from one carrying a device tuned to a different frequency band, but two satellites carrying the same Van Atta array will return the same signature. The RF interrogation also requires a ground source of the appropriate frequency. However, Van Atta array devices are entirely passive and extremely low SWaP, making them easy to include on small satellites and CubeSats. NTE devices have flown in space but results from those flight experiments have not been published to date.



*Figure 12.5: NTE Van Atta array retro-reflector in the Ku-band, fits standard 1U panel, tuned to HAX RADAR frequency. Credit: Naval Information Warfare Center.*

### 12.5.2 Laser-Interrogated Corner Cube Reflectors

Corner cube reflectors (CCRs), long used in the space industry, are special mirrors designed to reflect laser light back in the direction from which it arrived. They require no internal energy source. When illuminated by a laser, they provide a return signal that can be detected on the ground by a fast camera, as seen in figure 12.6. Putting a different number of CCRs on a set of CubeSats allows the ground station to differentiate between the CubeSats (i.e., a CubeSat with one CCR will produce a different return signal from another with two CCRs or three CCRs, etc.). One can use a laser and telescope system like those employed by the International Laser Ranging Service (ILRS) (23), which are high TRL and have been operating for decades. Precise orbital information is required to lase the CubeSat and receive a return signal, and the number of satellites that can be uniquely identified is limited by the number of corner cube reflectors that can be attached.

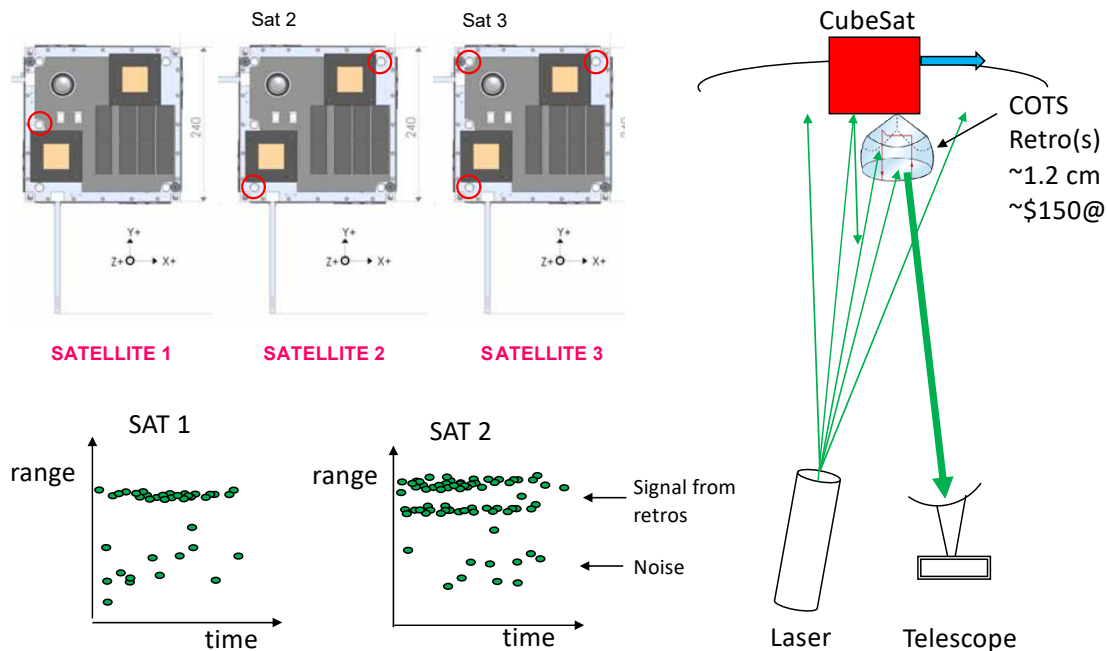


Figure 12.6: Corner Cube Reflectors. Credit: The Aerospace Corporation.

### 12.5.3 Passive Increase in Albedo

The simplest method of increasing trackability of satellites involves using high-albedo paint, special tape, or other simple methods to increase the optical or radar visibility of a small satellite, allowing it to be more easily detected by ground-based systems (24). White-colored thermal paint has been used for years to increase the ability of satellites to reject heat, which also helps make the satellites more visible and more trackable. Additionally, CubeSats often deploy a mission-specific configuration of wire antennas and/or cylindrical boom structures which can serve as unique identifiers using ground-based optical or radar characterization (25). Such approaches are simple, require little to no SWaP, and are readily available, but don't uniquely identify the satellite, and are limited in their effectiveness.

### 12.6 Future Efforts

Many in the community are aware of the "CubeSat confusion" issue, and there is a ground-swell of desire to make progress in mitigating this problem. Regulators have recognized the issue (27), and one of the consolidators, SpaceFlight, Inc., has announced their Sherpa orbital transfer vehicle will take tracking and identification technologies into space as hosted payloads aboard some of their upcoming dispenser satellite flights to increase their TRLs (28).

On the horizon, High Earth Robotics plans to create the Argus constellation – twelve optical 6U HERO-1 nanosatellites with space telescope payloads in GEO that can identify objects, take high resolution images of damaged satellites, and help identify solutions to avoid further decomposition. The constellation is intended to be resilient to interference and communications link interruption (40).



## 12.7 Summary

Small satellites and CubeSats are likely to continue increasing in popularity, and multi-manifest launches provide a very cost-effective way to get large numbers of satellites to space. Improving the ability to identify and track small satellites in space – especially those deployed in batches from a single launch vehicle – can help both small satellite owners and the entire space enterprise avoid the pitfalls of “CubeSat confusion.” It is important that the end-to-end cost and resulting capability are evaluated when choosing an option to ensure that the needed function is available.

For feedback solicitation, please email: [arc-sst-soa@mail.nasa.gov](mailto:arc-sst-soa@mail.nasa.gov). Please include a business email so someone may contact you further.

## References

- (1) Spaceflight. [Online] 2021. Accessed March 3, 2021. Available at: <https://spaceflight.com>
- (2) Nanoracks. “Nanoracks Books CubeSat Rideshare and Habitat Building Demonstration in Single SpaceX Falcon 9 Launch”. [Online] 2019. Accessed March 3, 2020. Available at: <https://nanoracks.com/rideshare-habitat-building-demonstration/>
- (3) Kirtland Airforce Base. “Space Test Program”. [Online] 2007. Accessed April 8, 2020. Available at: <https://www.kirtland.af.mil/About-Us/Fact-Sheets/Display/Article/826059/space-test-program/>,
- (4) M.A. Skinner. “CubeSat Confusion: how to avoid ‘dead on arrival’.” International Astronomical Congress 71st meeting, October 12-14, 2020.
- (5) I. Klotz. “SpaceX Rideshare Mission Spawns 12 Orphan CubeSats.” Aerospace Daily and Defense Report, August 12, 2019.
- (6) L. Grush. “Why the Air Force Still Cannot Identify more than a Dozen Satellites from One December Launch: The case of the unknown satellites.” [Online] 2019. Available at: <https://www.theverge.com/2019/4/2/18277344/space-situational-awareness-air-force-tracking-sso-a-spaceflight-CubeSats>
- (7) J. Bloch et al. “The ALEXIS Mission Recovery.” 17<sup>th</sup> annual American Astronomical Society (AAS) guidance and control conference, Keystone, CO, 1994.
- (8) B. Braun and S. Herrin. “The More, the Messier: ORS-3 lessons for multi-payload mission deployments.” 1-10. 10.1109/AERO.2016.7500582. 2016.
- (9) C.C. Venturini. “Improving Mission Success of CubeSats.” [Online] Aerospace Report number TOR-2017-01689. June 12, 2017. Accessed May 15, 2019. Available at: [https://www.nasa.gov/sites/default/files/atoms/files/improving\\_mission\\_success\\_of\\_CubeSats\\_-\\_tor-2017-01689.pdf](https://www.nasa.gov/sites/default/files/atoms/files/improving_mission_success_of_CubeSats_-_tor-2017-01689.pdf)
- (10) H.D. Voss et al.: “Globalstar Communication Link for CubeSats: TSAT, GEARRS1, and GEARRS2.” 29th AIAA/USU Conference on Small Satellites, Logan UT, August 9, 2015.
- (11) M.A. Skinner. “Making Small Satellites Visible: Nanosat tracking and identification techniques and technologies.” International Astronomical Congress 70th meeting, Washington DC, October 21-25, 2019.
- (12) H.D. Voss, J.F. Dailey, M.B. Orvis. “‘Black Box’ Beacon for Mission Success, Insurance, and Debris Mitigation.” 32nd Annual AIAA/USU Conference on Small Satellites, Logan UT. 2018.
- (13) A.J. Abraham. “GPS Transponders for Space Traffic Management.” Center for Space Policy & Strategy, Aerospace Corporation, April 2018.
- (14) J. Cutler, P. Seitzer, C.H. Lee *et al.* “Improved Orbit Determination of LEO CubeSats: Project LEDsat.” AMOS Technologies Conference, Maui, Hawai`i. September 2017



- (15) D.M. Palmer R.M. Holmes. "ELROI: A License Plate for Your Satellite." Journal of Spacecraft and Rockets, Vol. 55, No. 4, pp. 1014-1023, 2018.
- (16) S. Phan. "Spaceflight Industries' SSO-A Flight Launches with SRI International's CUBIT Technology Onboard, Developed to Track and Identify Low Earth Orbit Satellites." [Online] Accessed October 30, 2019. Available at: <https://www.sri.com/blog/spaceflight-industries-ssso-flight-launches-sri-internationals-cubit-technology-onboard>
- (17) G. Kirchner, L. Grunwaldt, R. Neubert, F. Koidl, M. Barschke, Z. Yoon, H. Fiedler, C. Hollenstein. "Laser Ranging to Nano- Satellites in LEO Orbits: Plans, Issues, Simulations." 18th International Workshop on Laser Ranging, Fujiyoshida, Japan. 2013.
- (18) H.D. Voss et. al.: "Black Box' RF Sat-Link for Space Debris, Mission Success and Risk Mitigation." First International Orbital Debris Conference, Sugar Land, TX. 2019.
- (19) D.M. Palmer et. al. "Progress Towards the ELROI Satellite License Plate." 34<sup>th</sup> Annual Conference on Small Satellites, Logan, UT. 2020.
- (20) D. Bird. "Design and Manufacture of a Low-Profile Radar Retro-Reflector." RTO SCI Symposium on "Sensors and Sensor Denial by Camouflage, Concealment and Deception", Brussels, Belgium, April 19-20, 2004, and published in RTO-MP-SCI-145.
- (21) D. Lane et. al. "Nanosatellite Tracking using Passive Retro-Reflectors." SSC20-WKIV-04, 34<sup>th</sup> Annual Conference on Small Satellites, Logan, UT, 2020.
- ~~(22) N/A~~
- (23) NASA. "ILRS Overview," [Online] May 9, 2016. Accessed July 2022. Available at: <https://ilrs.gsfc.nasa.gov/about/Overview.html>
- (24) D. Hall. "Optical CubeSat Discrimination." AMOS Technical Conference, September 2008.
- (25) C. Chong and M. Shozo. "Metrics for feature-aided track association." 9th International Conference on Information Fusion, IEEE, 2006.
- (26) ExoAnalytics Solutions. "Space Domain Awareness (SDA)." [Online] 2020. Accessed March 18, 2020. Available at: <https://exoanalytic.com/space-domain-awareness>
- (27) US Federal Communications Commission, "Orbital Debris in the New Space Age, Report and Order and Further Notice of Proposed Rulemaking." FCC-20-54, paragraph 62, April 24, 2020.
- (28) J. Sorensen. "SpaceFlight Inc. Unveils Next-gen Orbital Transfer Vehicle to Fly Aboard Next SpaceX Rideshare Mission." [Online] July 15, 2020. Accessed: 2020. Available at: <https://spaceflight.com/spaceflight-inc-unveils-next-gen-orbital-transfer-vehicle-to-fly-aboard-next-spacex-rideshare-mission/>
- (29) Launch Conjunction Assessment Handbook. LAUNCHCONJUNCTION ASSESSMENT HANDBOOK VERSION 1.0, DECEMBER 2018. 18 SPCS Process for Launch Conjunction Assessment, JFSCC, 18th Space Control Squadron Combined Space Operations Center (CSpOC)Vandenberg Air Force Base, California, [www.space-track.org](http://www.space-track.org)
- (30) S. Erwin. "Space Fence surveillance radar site declared operational". [Online] Accessed September 29, 2020. Available at: <https://spacenews.com/space-fence-surveillance-radar-site-declared-operational/>
- (31) Massachusetts Institute of Technology, Lincoln Labs. "Haystack Ultrawideband Satellite Imaging Radar." [Online] 2022. Accessed July 2022. Available at: <https://www.il.mit.edu/r-d/projects/haystack-ultrawideband-satellite-imaging-radar>
- (32) NASA. "NASA Releases Best Practices Handbook to Help Improve Space Safety." [Online] December 15, 2020. Accessed 2021. Available at: <https://www.nasa.gov/press-release/nasa-releases-best-practices-handbook-to-help-improve-space-safety>
- (33) NASA. NID 7120.132 Collision Avoidance for Space Environment Protection. November 19, 2021.
- (34) D. Murakami, S. Nag, M. Lifson, P. Kopardekar. "Space Traffic Management with a NASA UAS Traffic Management (UTM) Inspired Architecture." AAIAA SciTech Forum, San Diego, California, 7-11 January 2019.



- (35) NASA. "Conjunction Assessment Risk Analysis." [Online] 2022. Accessed 2022. Available at: <https://cms.nasa.gov/conjunction-assessment>
- (36) P. Marzioli, A. Gianfermo, L. Frezza, D. Amadio, N. Picci, F. Curiano, M.G. Pancalli, E. Vestito, J. Schachter, M. Szczerba, D. Gu, A. Lin, J. Cutler, S. Pirrotta, F. Santoni, P. Seitzer, F. Piergentili. "Usage of Light Emitting Diodes (LEDs) for improved satellite tracking." *Acta Astronautica* 179 (2021) 228–237.
- (37) European Space Agency. "LEDSAT passes Flight Acceptance Review and now has a ticket to orbit." [Online] June 15, 2021. Accessed 2021. Available at: [https://www.esa.int/Education/CubeSats\\_-\\_Fly\\_Your\\_Satellite/LEDSAT\\_passes\\_Flight\\_Acceptance\\_Review\\_and\\_now\\_has\\_a\\_ticket\\_to\\_orbit](https://www.esa.int/Education/CubeSats_-_Fly_Your_Satellite/LEDSAT_passes_Flight_Acceptance_Review_and_now_has_a_ticket_to_orbit)
- (38) C. Walker et al. "Impact of Satellite Constellations on Optical Astronomy and Recommendations Toward Mitigations." NSF's NOIRLab (Communications, Education & Engagement division).
- (39) Engagement division).
- (40) M. Boggett. "LeoLabs Partners with SpaceX to Track Starlink Satellite Deployments". [Online] 2020. Accessed June 16, 2021. Available at: [https://medium.com/@leolabs\\_space/leolabs-partners-with-spacex-to-track-starlink-satellite-deployments-4e579052546f](https://medium.com/@leolabs_space/leolabs-partners-with-spacex-to-track-starlink-satellite-deployments-4e579052546f)
- (41) M. Skinner, M. Coletti, M.C. Voss, T. Svitek, J.C. Lee, K. Auman, H. Patel, E.J. Moyer. "Mitigating CubeSat Confusion: results of in-flight technical demonstrations of candidate tracking and identification technologies." 72nd International Astronautical Congress (IAC), Dubai, United Arab Emirates, 25-29 October 2021.
- (42) M. Skinner, K. Auman, E.J. Moyer, M.C. Voss, J.C. Lee, R. Olcott, H.E. Weiher, A.M. Goodyear, D.A. Hinkley. "Mitigating CubeSat Confusion: further results of in-flight technical demonstrations of candidate tracking and identification technologies," 73rd International Astronautical Congress (IAC), Paris, France, 18-22 September 2022.



## Chapter Contents

Chapter Glossary .....	ii
13.0 Deorbit Systems .....	346
13.1 Introduction .....	346
13.2 State-of-the-Art – Passive Systems .....	348
13.2.1 Main High TRL Drag Devices .....	348
13.2.2 Deployable Booms .....	353
13.2.3 Electromagnetic Tethers.....	355
13.3 State-of-the-Art – Active Systems .....	355
13.3.1 TechEdSat Series Exo-Brake .....	355
13.3.2 RemoveDebris Consortium Partners .....	356
13.3.3 Astroscale.....	357
13.3.4 ClearSpace.....	357
13.3.5 Momentum.....	358
13.3.6 D-orbit.....	358
13.3.7 Altius Space Machines .....	358
13.4 Summary.....	359
References.....	360





## Chapter Glossary

(ADCS)	Attitude Determination and Control System
(AEOLDOS)	Aerodynamic End-of-Life Deorbit system for CubeSats
(AFRL)	Air Force Research Laboratory
(ARC)	Ames Research Center
(CRD2)	Commercial Removal of Debris Demonstration
(D3)	Drag Deorbit Device
(DOM)	De-orbit Mechanism
(EOL)	End-Of-Life
(FURL)	Flexible Unfurlable and Refurlable Lightweight
(GCD)	Game Changing Development
(GTO)	Geosynchronous Transfer Orbit
(HSC)	High Strain Composite
(IADC)	Inter-Agency Space Debris Coordination Committee
(ISS)	International Space Station
(JAXA)	Japan Exploration Space Agency
(MSFC)	Marshall Space Flight Center
(RODEO)	Roll-Out DeOrbiting Device
(SBIR)	Small Business Innovation Research
(SSO)	Sun-synchronous orbit
(STMD)	Space Technology Mission Directorate
(TRL)	Technology Readiness Levels
(UTIAS-SFL)	University of Toronto Institute for Aerospace Studies Space Flight Laboratory
(VESPA)	Vega Secondary Payload Adapter

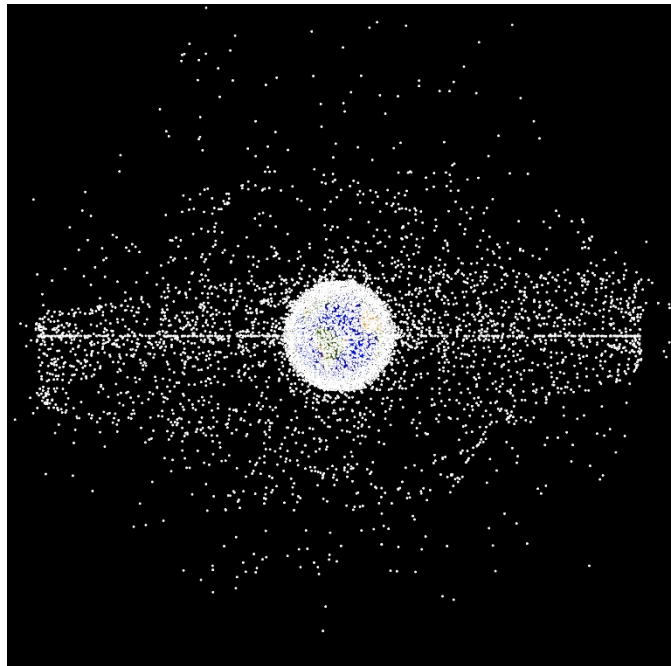


## 13.0 Deorbit Systems

### 13.1 Introduction

The threats of space debris are increasing with the launch of multi-satellite constellations, particularly in low-Earth orbit (LEO). Currently, the general guideline is that satellites in LEO must deorbit or be placed in graveyard orbit within a maximum of 25 years after the completion of their mission (1). However, on September 29, 2022, the Federal Communications Commission (FCC) adopted a new rule to reduce this requirement to 5 years for US-licensed satellites, as well as those from other countries that seek to access the US market (40) (64). Therefore, spacecraft under 2000 km in altitude will have to deorbit as soon as it is applicable and no longer than 5 years after end of mission. This requirement will apply to spacecraft launched two years after the rule is approved. Up to the date of publication of this report, this rule does not specifically apply to NASA satellites that are not licensed through the FCC. As of November 2022, it is estimated that only a small percentage of NASA satellites launched every year may have to follow this rule. Current discussions at the agency and federal level are ongoing to determine the final policies (64).

The rate of decay in LEO depends on several factors. In particular, the initial orbit allocation and the ballistic coefficient play a fundamental role on the ability to comply with the regulations. Estimates of the accumulation of orbital debris suggest approximately 500,000 objects with a diameter 1 – 10 cm, and over 25,000 pieces with diameters >10 cm, are in orbit between geostationary equatorial and low-Earth orbit altitudes (2). Of the 11,370 satellites that have been placed in orbit 60% are still in orbit and only 35% are still operational. As of November 2022, it is estimated that all the space debris in orbit exceeds a collective mass of 9000 metric tons (2)(63). Figure 13.1 is a representation of the debris around Earth. The objective of the NASA Orbital Debris Program Office along with the Inter-Agency Space Debris Coordination Committee (IADC) is to limit the creation of space debris. NASA requires that all spacecraft must either deorbit within 25 years or move into a graveyard orbit for safe storage, while the IADC is a non-binding recommendation (3). However, as explained earlier in this chapter, the new FCC rule will reduce this value to just 5 years (40) for most commercial spacecraft (64).



*Figure 13.1: Illustration of all known space debris in orbit around Earth. Credit: NASA.*

Small spacecraft missions typically stay in LEO, as it is a more accessible, less expensive orbit to reach, and there are rideshare opportunities from several commercial launch providers. Additionally, the proximity to Earth can relax spacecraft mass, power and propulsive constraints, and also the radiation environment in LEO is relatively benign for altitudes below 1000 km. Small spacecraft launched at or around the International Space Station (ISS) altitude (~400 km) naturally decay in under 5 years. However, at orbital altitudes beyond 500 km, there is no guarantee that a small spacecraft will naturally decay in 5 years to comply with the new FCC rule,



due to potential low atmospheric density conditions and the differences in ballistic coefficient, as seen in figure 13.2. To ensure compliance with the 5-year requirement, satellites would need to increase their ballistic coefficient (or area to mass ratio). Deorbit technologies such as drag devices are important in this context since they can provide a way to effectively address this issue.

Figure 13.2 shows various representative small satellites with various masses, drag areas and initial orbits, under two atmospheric density conditions, near the maximum and the minimum solar cycle. For instance, a 6U CubeSat with  $0.06 \text{ m}^2$  drag area and 14 kg of dry mass decays at a faster rate than a more massive satellite with 100 kg and  $0.5 \text{ m}^2$  of drag area, showing the important effect

the ballistic coefficient plays in the orbit propagation. The majority of launched small spacecraft do not carry on-board propulsion, making them unable to achieve graveyard orbits for decommissioning. Therefore, they need to rely on deorbit techniques such as increasing the drag area by rotating the spacecraft if they are in low altitudes. Some spacecraft, if their exposed drag area is not enough to meet the new 5-year requirement, can use deorbit devices such as drag sails (passive systems) or external deorbit services (active systems) to deorbit.

In addition, the varying solar weather conditions affect the deorbit performance for a given altitude. The drag force that satellites experience is increased when the Sun is at the maximum of the solar cycle, producing a faster decay. When the Sun emits extra energy in the atmosphere, higher density layers occupy LEO altitudes, producing a stronger drag force as a result (66). The solar maximum typically occurs every 11 years and can have a severe impact on orbital lifetimes, so some missions plan their launch periods around the solar cycle. With the new 5-year rule, more companies may want to consider the solar cycle for their launch plans as the deorbit time can be reduced by more than 10 years in some cases as seen in figure 13.2.

Passive deorbit systems have gained maturity since the last iteration of this report, and there are more devices with high Technology Readiness Levels ( $\text{TRL} \geq 8$ ) that are guaranteed to satisfy the stricter 5-year requirement. Several missions have demonstrated passive deorbit systems, and an increasing number of small spacecraft have been carrying these devices.

Traditionally passive systems were the main option for deorbiting due to their increased simplicity. However, recently active methods are gaining traction. On one hand, active deorbiting requires attitude control and, in some case, also surplus propellant post-mission, such as a steered drag

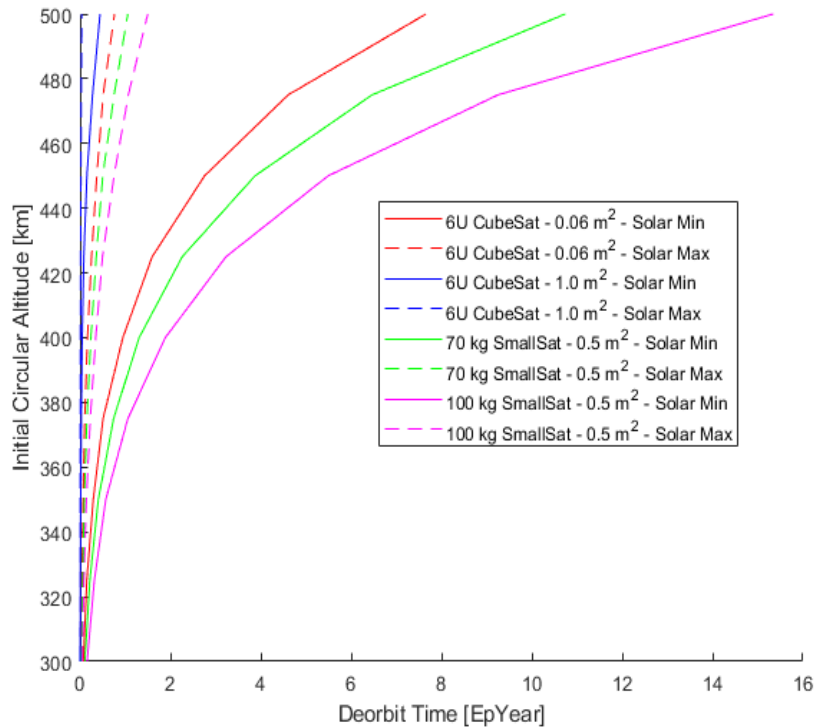


Figure 13.2: Initial orbit altitudes yield different lifetimes depending on the ballistic coefficient of the spacecraft. Three representative area-to-mass ratios are shown. Note that the propagation stops at 25 years, but the initial altitudes yield even longer times. Credit: NASA.



sail that relies on a functioning attitude control system, or on actuators for pointing the sail. On the other hand, some of the new active deorbiting solutions include a separate spacecraft that can attach to the defunct satellite to bring it down to lower orbits where the satellites can complete the deorbit using their own drag decay. Some recent small spacecraft like the European RemoveDebris project have even implemented a variety of active and passive deorbit systems within the same mission. This technology demonstration mission included both active and passive systems such as a net experiment, a harpoon, and a more traditional drag sail. The mission tested these systems to prove feasibility of such technologies in space by deploying two separate 2U CubeSats from the main spacecraft to simulate space debris. After the mission was completed, the passive system was deployed and is currently deorbiting the main satellite to burn in the atmosphere.

Propulsive devices have also been used for deorbiting techniques; however, this approach is still considered risky due to potential failure or malfunction of either the spacecraft, up until its final stage of decommission, or the propulsive technology itself. Even if the spacecraft carries enough excess propellant for its own active decay approach, it may also need adequate attitude control and navigation capabilities after the mission for a controlled reentry. This method may require navigation and mission operation capabilities, making it inconvenient and more costly for some small spacecraft missions (4). Overall, active deorbiting methods are still challenging for small spacecraft, as this demand increases design complexity and uses valuable mass and volume. This report studies the state-of-the-art for both systems, excluding spacecraft that carry their own propulsive means. For those systems, please refer to the Propulsion chapter of this report.

The information described below is not intended to be exhaustive but provides an overview of current state-of-the-art technologies and their development status for a particular small spacecraft subsystem. It should be noted that TRL designations may vary with changes specific to payload, mission requirements, reliability considerations, and/or the environment in which performance was demonstrated. Readers are highly encouraged to reach out to companies for further information regarding the performance and TRL of described technology. There is no intention of mentioning certain companies and omitting others based on their technologies or relationship with NASA.

## **13.2 State-of-the-Art – Passive Systems**

Passive deorbit methods require no further active control after deployment. Recent developments have increased the number of available options with flight heritage. This chapter will emphasize recent developments rather than past missions. In addition, the chapter aims to discuss devices used exclusively for deorbit purposes, excluding technologies such as solar sails that are used for other propulsive applications.

### **13.2.1 High TRL Drag Sails**

Drag devices represent the most common deorbit device for satellites orbiting in low-Earth orbit. They present an advantage due to simplicity and by not occupying large volumes while stowed. For certain area-to-mass ratios in altitudes equal to or lower than 800 km, drag devices can be deployed to increase the drag area for faster deorbiting in compliance with the new 5-year requirement. Recently, this technology has been implemented in several small spacecraft missions, and several companies and institutions are developing prototypes that are increasingly more mature, providing solutions to the space debris problem for missions that do not have resources for an active system. Table 13-1 displays current state-of-the-art technology for passive deorbit systems. These are the most developed technologies for deorbiting systems as of 2022.



Table 13-1: Launched Drag Sails

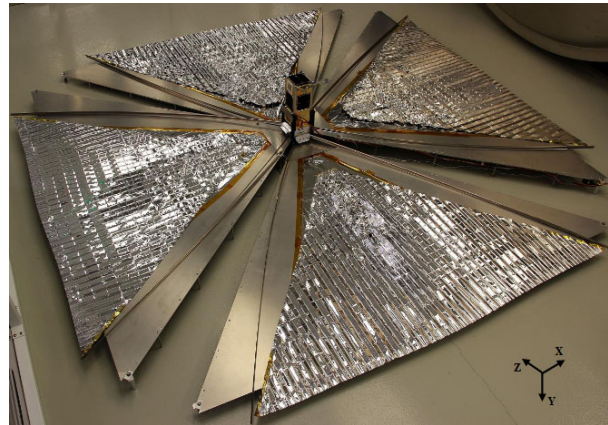
Product	Manufacturer	Mission host and launch mass (kg)	Device mass (kg)	Initial orbit (alt and inc)	Launch Year	Deployment Year	Drag area (m <sup>2</sup> )	TRL	Ref
NanoSail-D2	NASA MSFC/ARC	FASTSAT (4.2 kg)	N/A	650 km 72 deg	2010	2011	10	7-9	(1)
Drag-Net	MMA Design	ORS-3 Deployed a Minotaur Upper Stage (100 kg)	2.8	N/A	2016	2016	14	7-9	(5)
Icarus-1	Cranfield Aerospace Solutions	SSTL TechDemoSat-1 (157 kg)	3.5	635 km	2014	2019	6.7	7-9	(6)
Icarus-3	Cranfield Aerospace Solutions	Carbonite-1 (80 kg)	2.3	650 km 98 deg	2015	Future (in-orbit)	2	7-9	(6)
DOM	Cranfield Aerospace Solutions	ESEO (45 kg)	0.5	572 × 588 km 97.77 deg	2018	Future (in-orbit)	0.5	7-9	(6)
Terminator Tape	Tethers Unlimited, Inc.	Prox-1 (71 kg)	0.808	717 km 24 deg	2019	2019	10.5	7-9	(7)
DragSail	Surrey Space Centre	InflateSail (3.2 kg)	N/A	505 km 97.44 deg	2017	2017	10	7-9	(8)
Exo-Brake	NASA	TES-5 (3.4 kg)	TBC	405 km 51.5 deg	2014	2015	0.35	7-9	(9)
Exo-Brake	NASA	TES-7 (3 kg)	TBC	485 × 513 km 60.7 deg	2021	2021	1.2	8-9	(43)
Exo-Brake	NASA	TES-13 (4 kg)	TBC	505 km 45 deg	2022	2022	0.083	8-9	(43)
Exo-Brake	NASA	TES-15 (4.5 kg)	TBC	215 × 270 km 137 deg	2022	2022	0.087	8-9	(43)



removeDebris	Surrey Space Centre	removeDebris (100 kg)	N/A	405 km 51.5 deg	2018	2019	16	7-9	(10)
CanX-7	UTIAS-SFL	3U CubeSat (3.6)	0.8 (4 modules of 0.2)	688 km 98 deg	2016	2017	4	7-9	(11)

Several small spacecraft missions have built and launched passive deorbit technologies in the past using a drag sail or boom. The NanoSail-D2 mission, which was deployed in 2011 from the minisatellite *FASTSat-HSV* into a 650 km altitude and 72° inclined orbit, demonstrated the deorbit capability of a low mass, high surface area sail. The 3U spacecraft, developed at NASA Marshall Space Flight Center (MSFC), reentered Earth's atmosphere in September 2011.

CanX-7, still in orbit at an initial 800 km Sun-synchronous orbit (SSO), deployed a drag sail in May 2017. The sail was developed and tested at University of Toronto Institute for Aerospace Studies Space Flight Laboratory (UTIAS-SFL) (figure 13.3).



*Figure 13.3: CanX-7 deployed drag sail during testing. Credit: Cotten et al. (2017).*

The CanX-7 deorbit technology consists of a thin film sail that is divided in four individual modules that each provide 1 m<sup>2</sup> of drag area. These sail sections are deployed mechanically with spring booms, which help to preserve the geometry. Each module also has electronics for individual telemetry and command. This feature allows different sections to be controlled separately to mitigate risk of a single failure, and to allow custom adaptability to various spacecraft geometries and ballistic coefficient requirements for other missions. For the 2017 deployment, all four segments functioned successfully. The deorbit performance was measured after a month. The deorbit profile showed that the effects of the sail segments accounted for an altitude decay rate at the time of measurement of 20 km/year, which results in a significant increase from the previous 0.5 km/year. These rates are expected to increase as the atmospheric density increases exponentially with lower altitudes (11).

The Technology Educational Satellite, also known as TechEdSat-n (TES-n), program at NASA Ames Research Center (ARC) has contributed significantly to the development of drag devices. It consists of a series of nanosatellite technology demonstrations in collaboration with several universities including San Jose State University and the University of Idaho. One of the main goals of the program is to test and improve deorbiting techniques and develop a unique targeting capability with their own drag device design known as the Exo-Brake. The Exo-Brake deorbit system is an atmospheric braking system that distinguishes itself from other drag devices since it is more akin to a parachute instead of a solar sail due to its primary tension-based elements. This becomes fundamental for accurate deorbit targeting since the device must retain its shape without collapsing during those critical reentry moments occurring at the atmosphere interface altitude of 100 km, known as the Von Karman line (12). The Exo-Brake has been used as both a passive and a controlled active deorbit system, therefore it is included in both sections.

The Exo-Brake development is funded by the Entry Systems Modeling project within the NASA Space Technology Mission Directorate's (STMD) Game Changing Development (GCD) program. The Exo-Brake was first implemented as a passive deorbit device on the TechEdSat missions TES-3, TES-4, and TES-5. Recent CubeSats have also used it for controlled mission deorbiting. Two of the four TechEdSat spacecraft using a passive Exo-Brake were TES-5 and TES-7, while TES-13 and TES-15 also used variations of the TES-7 design. TES-5 was deployed from the ISS in March 2017 and demonstrated this deorbiting capability after 144 days in orbit with the Exo-Brake deploying at 400 km. TES-7, a 2U CubeSat that launched January 2021, onboard Virgin

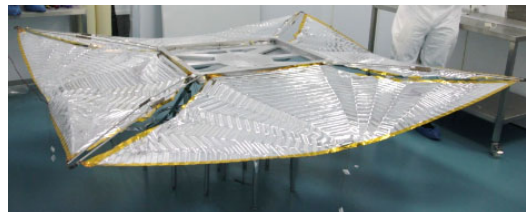


Orbit's LauncherOne rocket, was placed into orbit at 500 km (13) and decayed May 2022. TES-13 was launched January 2022 with other CubeSats on the third successful Virgin LauncherOne flight and carried an Exo-Brake onboard to demonstrate autonomous navigation and reentry over specific Earth locations. TES-15 was launched October 2022 aboard a Firefly Aerospace Alpha Launcher. Its primary objective was to test an Exo-Brake designed to sustain much higher temperatures than in previous missions. The satellite also included a simple ablator in the nose cap that is expected to last deeper into the atmosphere before burning up. After this experiment, TES-15 should be able to validate higher heating rates and the flight dynamics ability to target an Earth entry point (43). The satellite reentered on October 7, 2022, and the team is analyzing the data to study the performance of this latest flight (44).

The Surrey Space Centre based in the United Kingdom has developed the DragSail technology, which was implemented in a family of missions. The Inflatesail 3U CubeSat first demonstrated this technology. The European Commission QB50 program and the DEPLOYTECH partnership that included German Aerospace Centre (DLR) and NASA Marshall Space Flight Center, among others, funded it. This mission was launched in 2017 and included a mast/drag-sail technology that successfully deorbited the satellite in just 72 days. This achievement was the first time a spacecraft has deorbited using European inflatable and drag-sail methods (8).

The RemoveDebris mission was developed under the European Commission FP7 program by a consortium of several institutions such as Airbus and the Surrey Space Centre. The mission consisted of a 100 kg small spacecraft that was deployed from the ISS in 2018. One of the experiments it carried was a passive drag augmentation device consisting of a sail. The sail was deployed in March 2019, however, trajectory data showed it only partially deployed since no significant altitude change was measured. The lessons learned from this incident were implemented in another version for the Space Flight Industries' SSO-A mission that incorporated two of these sails. In that case, the assembly did not include an inflatable boom (10).

As part of the ESA CleanSat program, Cranfield Aerospace Solutions in the United Kingdom has also developed a variety of drag augmentation systems. The first demonstrated technology was the Icarus-1, which flew in the TechDemoSat-1 mission from SSTL, launched in 2014. Another version also flew in the Carbonite-1 spacecraft, launched in 2015. The concept is similar to other drag devices in which the drag increases by deploying a membrane sustained by rigid booms. The Icarus technology consists of a thin aluminum structure located around the satellite side panel that contains four stowed Kapton trapezoidal sails and booms. The mass of the system is 3.5 kg for about 5 m<sup>2</sup> of sail area for the Icarus-1, and 2.3 kg for 2 m<sup>2</sup> for the Icarus-3 (figure 13.4). Both sails deployed successfully and are expected to deorbit both spacecraft in less than 10 years. The second technology developed by Cranfield Aerospace Solutions is a de-orbit mechanism (DOM) device which consists of a version of the drag sail presented in a smaller cuboid outline. The mechanical system varies from Icarus since the sails are triangular and the booms work as tape springs themselves. This system flew in the European Student Earth Orbiter on a 45 kg satellite that carried several student payloads. Among them, the Cranfield University DOM module will deorbit the spacecraft after decommissioning. The sail has an area of 0.5 m<sup>2</sup> with a mass of 0.5 kg (6).



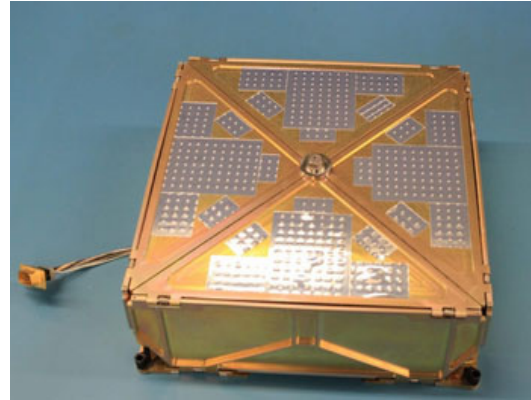
*Figure 13.4: Icarus-3 drag sail implemented in the Carbonite-1 mission. Credit: Cranfield Aerospace Solutions.*

MMA Design LLC, a company from Colorado, has patented the dragNET de-orbit system. The 2.8 kg module (figure 13.5) deorbited the ORS-3 Minotaur Upper Stage in 2.1 years after launch in November 2013. DragNet features four stowed thin membranes that deploy through a single



heater-powered actuator. The sail has an area of 14 m<sup>2</sup> that can effectively deorbit a 180 kg spacecraft at an altitude of 850 km in less than 10 years (5).

Redwire Space holds an exclusive license for the Flexible Unfurlable and Refurlable Lightweight (FURL) solar sail developed and tested by the Air Force Research Laboratory (AFRL). FURL extends and retracts with four booms stored around a common hub. Small satellites can employ solar sails to control attitude, change planes or remain in their proper orbits and then retract the sail once it reaches its destination. This technology could be applied to deorbit applications as well.



*Figure 13.5: DragNet module. Credit: MMA Design LLC.*

Purdue University has developed a drag device with a pyramid geometry that can deorbit a satellite placed in a geosynchronous transfer orbit (GTO). The Aerodynamic Deorbit Experiment (ADE), developed jointly with CalPoly and Georgia Tech, will consist of a 1U CubeSat technology demonstration deployed from a Centaur upper stage in a future Atlas V rocket from United Launch Alliance. Once deployed, the device will occupy an area of about 1 m<sup>2</sup> to decrease the ballistic coefficient of the spacecraft and reduce the perigee altitude during each pass. Consequently, the expected lifetime of the ADE mission will be 50 – 250 days instead of the estimated seven years (21). The technology has been licensed to Vestigo Aerospace which is commercializing the drag device with their Spinnaker series of drag sails and has been awarded funding from NASA's Phase II Small Business Innovation Research (SBIR) Program (37). The company, which is licensing the technology through Purdue University, expects to start sales in 2023 for small satellites. An initial flight test was attempted in September 2021 aboard the first Firefly Aerospace Alpha rocket. The Spinnaker3 concept sail consisted of a 18 m<sup>2</sup> sail, and was supposed to deorbit the upper stage of the launch vehicle, however the launch ended with an explosion shortly after liftoff (45). Vestigo is developing two main products, a sail targeted for small satellites that has a surface area of 1.77 m<sup>2</sup> and a larger 18 m<sup>2</sup> sail for objects weighing up to 1000 kg (46).

In June 2022, China launched a Long March 2D rocket that carried a 25 m<sup>2</sup> drag sail attached to the payload adapter on the rocket upper stage. The 300 kg object could deorbit within two years due to this technology (48).

BAMA 1 was a 3U CubeSat developed by the University of Alabama that carried a drag sail module to rapidly deorbit the satellite. It was launched aboard the Astra Rocket 3.3 but was unable to reach orbit due to launch failure (49).

### **13.2.2 Deployable Booms**

Deployable booms, while not strictly a deorbit device themselves, compose a vital part of many deorbit systems. They are structural components that can be stowed during launch, then deployed once in space to provide the support structure required for various drag sail designs. More specific information regarding deployable booms can be found in Chapter 6: Structures, Materials, and Mechanisms.

In 2019, the first ROC-FALL drag-based deorbit device was launched on the General Atomics OTB-1 spacecraft (38). Built by Redwire Space, the ROC-FALL device consists of a rectangular sail supported by a High Strain Composite (HSC) boom that is co-wrapped on a spool and restrained with a strap for stowage. The ROC-FALL system is scalable both in width and length to accommodate a variety of spacecraft sizes, and the heritage system sail measures 3.8 x 0.45

m in deployed area and rolls to a 0.04 x 0.45 m tube + supporting mechanism. The ROC-FALL is tip-rolled and passively deployed from the spacecraft. Redwire Space offers a variety of deployable boom technologies with a wide range of applications on small spacecrafts including open lattice mast, rollable tubes, and telescopic booms that can be applied on small spacecraft.

The University of Florida has developed the Drag Deorbit Device (D3) 2U CubeSat which provides attitude stabilization and modulation of the satellite drag area at the same time, making the overall solution an alternative to regular ADCS units. Four 3.7 m long tape spring booms form the D3, which can deorbit a 15 kg satellite from an altitude of 700 km. A final design has already been tested and simulated, including thermal vacuum and fatigue testing (18) (19). Figure 13.6 shows two images of the final design. The mission was selected by NASA through the CubeSat Launch Initiative, which included eligibility for placement on the ELaNa-45 launch manifest (20). On September 6, 2022, D3 was successfully placed in orbit by the NanoRacks NRCSD CubeSat deployer that is located on the International Space Station (47).

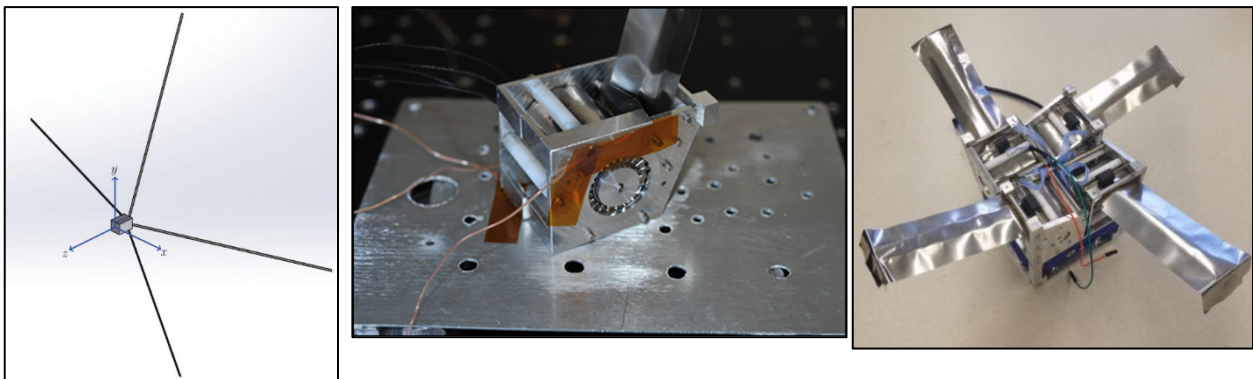


Figure 13.6: D3 CAD design (left), boom inside thermal vacuum chamber (center), and prototype design (right). Credit: Omar et al., 2019, and Martin et al., 2019.

Composite Technology Development, Inc. has developed the Roll-Out DeOrbiting device (RODEO) that consists of a lightweight film attached to a simple, ultra-lightweight, roll-out composite boom structure (figure 13.7). This is a self-deploying system where the stored strain energy of the packaged boom provides the necessary deployment force. It was successfully deployed on suborbital RocketSat-8 (138 kg) on August 13, 2013 (14).



Figure 13.7: RODEO stowed. Credit: Composite Technology Development, Inc.

### 13.2.3 Electromagnetic Tethers

In addition to drag sails, an electromagnetic tether has proven to be an effective deorbit method. This technology uses a conductive tether to generate an electromagnetic force as the tether system moves relative to Earth's magnetic field. Tethers Unlimited (now Amergint Technologies) developed terminator tape that uses a burn-wire release mechanism to actuate the ejection of the terminator's cover, deploying a 70 m long

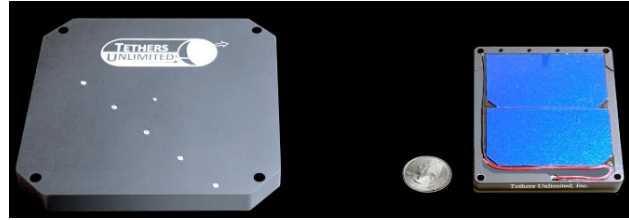


Figure 13.8: Image of the NSTT (left) and the CSTT modules. Credit: Amergint Technologies.

conductive tape at the conclusion of the small spacecraft mission (7). There are currently two main modules. The first, NSTT for NanoSats has a mass of 0.808 kg. The second, CSTT, is made for CubeSats and has a mass of just 0.083 kg. Figure 13.8 shows an image of both systems respectively (16). The 70 m long NSTT has been implemented in the 71 kg Prox-1 satellite, launched in mid-2019 by AFRL.

DragRacer, an experiment jointly developed by Tethers Unlimited, Millennium Space Systems, RocketLab, and TriSept Corp., consisted of a satellite (Alchemy) with the terminator tape, and another satellite (Augury) without it, to characterize the tape performance (17). Alchemy reentered in July 2021 while Augury is still in orbit.

The AeroSpace Corporation 2 kg and 1.5 AeroCube 5A and 5B CubeSats, launched in 2015, also incorporated a version of the terminator tape.

## 13.3 State-of-the-Art – Active Systems

Several companies have been increasingly offering active spacecraft-based deorbit systems. Space startups such as AstroScale, ClearSpace, and D-orbit have long-term plans and have already started initial technology demonstration missions. These systems consist of separate, dedicated spacecraft that attach to decommissioned satellites to place them into decaying or graveyard orbits. In December 2019, Iridium stated that they would like to pay for an active deorbit system to remove 30 of their defunct satellites (22). In addition, for NASA missions, the NASA STD-8719.14C document stipulates that all spacecraft using controlled reentry processes, the designed trajectory must guarantee that no remaining debris that could impact with a kinetic energy greater than 15 Joules is nearer than 370 km from foreign landmasses, or within 50 km from any territory of the United States and the permanent ice pack of Antarctica (10) (65).

This section covers some of the main stakeholders in the industry that are working towards the implementation of active space debris removal, as well as some other promising technologies that can potentially be used for actively deorbiting spacecraft in the future.

### 13.3.1 TechEdSat Series Exo-Brake

The Exo-Brake introduced earlier in the passive systems also has active control capability. The TES-6 mission was the first to implement this technology with a 3.5U CubeSat with a mass of 3.51 kg that deployed its Exo-Brake from the rear of the satellite. It targeted a reentry over Wallops Flight Facility by modulating the drag device to adjust the ballistic coefficient as orbital determination about the satellite state became available over time. The Iridium gateway enabled the command of the brake, which proved to significantly affect the reentry time and consequently, the location of the Wallops target area. The spacecraft overshot the intended target range slightly as shown in the second image, since it could not achieve a lower 4 – 5 kg m<sup>-2</sup> ballistic coefficient configuration, which would have yielded suitable results if placed at 300 km (see figure 13.9).



Figure 13.9: Targeting of the TES-10 Exo-brake is achieved by modifying the drag area of the modulating Exo-brake. (Left) The plot includes actual GPS readings and the approximate ballistic coefficient achieved at different parts of the mission. (Right) The simulated reentry location of TES-10. The spacecraft overshot but still demonstrated the capability to target a particular location by modifying its ballistic coefficient. Credits: Jose Alvarellos et al. 2021/Sanny Omar/NASA.

However, the mission successfully demonstrated the reentry experiment and the command/control capability by overflying Wallops right before reentering. This technology was going to be demonstrated again in the TES-8 mission, although a power system failure occurred before the targeting process. It should be noted that the Exo-Brake was successfully deployed on TES-8, an improved version of the previous TES-5 and TES-6 devices. The TES-8 ballistic coefficient range was wider ( $6 - 18 \text{ kg m}^{-2}$ ), and enabled better control authority for targeting. TES-10 and upcoming TES-11 are also incorporating this design (12). TES-10 (figure 13.10) marked the second targeted deorbit flight test and successfully overflow NASA Wallops Flight Facility much like TES-6 (33). TES-15 reentered seven days after deployment, and the team is evaluating the data to determine the performance of a new version of the Exo-Brake.



Figure 13.10: TES-10 deployment from the ISS in July 2020. Credit: NASA.

### 13.3.2 RemoveDebris Consortium Partners

The RemoveDebris mission carried two 2U CubeSats that were ejected from the mothership to simulate space debris and demonstrate active deorbit capabilities. The first CubeSat, known as DebrisSat-1, deployed at a very low velocity from the main spacecraft and subsequently inflated a balloon that provided a larger target area. A 5 m diameter net was ejected from the main spacecraft just 144 seconds after deployment, capturing the CubeSat at a distance of  $\sim 11 \text{ m}$  from the mothercraft. The object, once enveloped in the net, re-entered the atmosphere in March 2019 (10). The RemoveDebris mission also carried another active debris technology consisting of a harpoon. In this scenario, a target platform attached to a boom was deployed from the main spacecraft. The mothership then released the harpoon at  $19 \text{ m/s}$  to hit the platform in the center. Once that occurred, the 1.5 m boom that connected the two objects snapped on one end. However, a tether secured the target in place, avoiding the creation of new debris. This resulted in the first demonstration of a harpoon technology in space. The harpoon target assembly had a dry mass of  $4.3 \text{ kg}$  (10).



### 13.3.3 Astroscale

Astroscale is a company founded in Japan with offices in the UK, the US, and Singapore. Their two main objectives are to provide services to address the end-of-life (EOL) scenario of newly launched satellites, and to proactively remove existing space debris. They collaborate with a variety of governmental and international organizations around the world (such as the US government, ESA, the European Union, or the United Nations) to position themselves as leaders of a more sustainable low-Earth orbit environment.

As part of the EOL campaign, the ELSA-d mission, which launched on March 22, 2021, consists of two spacecraft, with one acting as a 'servicer' and the other as a 'client' (29). They have launch masses of ~175 kg and ~17 kg respectively. The concept of operations is to perform rendezvous maneuvers by releasing the client from the servicer repeatedly to demonstrate the capability of finding and docking with existing debris. The technology demonstrations include search and inspection of the targets, as well as rendezvous of both tumbling and non-tumbling cases (29). In January 2022, the servicer spacecraft successfully released the client counterpart and initiated autonomous relative navigation over the course of multiple orbits as part of the mission plan (41). The ELSA-M spacecraft will leverage the lessons learned and technology demonstrated in this precursor mission to support a range of future satellite operators that may carry a compatible magnetic capture mechanism such as the Astroscale Docking Plate. The ELSA-M in-orbit demonstrator is planned to launch by the end of 2024 (54). It is important to note that several science missions undertake extensive efforts to make their spacecraft magnetically neutral, which may be a concern for this method and its application in some cases.

Regarding their active debris removal campaign, Astroscale is also working with national space agencies to incorporate solutions to remove critical debris such as rocket upper stages or defunct satellites. This campaign started with a partnership with the Japanese Space Agency (JAXA) in February 2020. This collaboration will result in the implementation of the Commercial Removal of Debris Demonstration project (CRD2) which consists of the removal of a large space debris object performed in two mission phases. Astroscale will be involved in both phases. The first phase consists of a satellite that identifies and acquires data from a JAXA rocket upper stage. The Active Debris Removal by Astroscale-Japan (ADRAS-J) satellite which will complete this first phase is scheduled to launch aboard a Rocket Lab Electron rocket in 2022 (42). Once deployed, the satellite is supposed to rendezvous with the upper stage to demonstrate proximity operations and obtain images to better understand the space debris environment (51). In August 2022, Astroscale was also selected to participate in the Phase II of the CRD2 project. The company will be responsible for the Front-Loading Technology Study which will focus on the ground test of hardware and software for close proximity operations and the capture mechanism design. This study is a requirement for satellite providers in the CRD2 Phase 2 mission (51).

Astroscale announced in May a \$3.5 million funding award from OneWeb, the global communications network, to further develop their technology with the goal of commercial services starting in 2024. The next iteration consists of the ELSA-M satellite which will be capable of deorbiting multiple satellites per mission. OneWeb has also committed to including a docking plate on their satellites that would facilitate future deorbit missions (31). In September 2022, Astroscale secured funding from the UK Space Agency to keep developing the latest mission phase of the Cleaning Outer Space Mission through Innovative Capture (COSMIC). This mission will be an evolution of the Astroscale ELSA-M platform with a goal of removing two defunct British satellites by 2026 (55).

### 13.3.4 ClearSpace

ClearSpace is a Swiss company founded as a spin-off from the Ecole Polytechnique Federale de Lausanne research institute. Their plans also include service contracts for active debris removal.



One of their proposed missions, ClearSpace One, which has been backed by ESA, will find, target, and capture a non-cooperative, tumbling 100 kg Vega Secondary Payload Adapter (VESPA) upper stage. The chaser spacecraft will be launched into a 500 km orbit for commissioning and initial testing before raising its altitude to the VESPA's 660 km orbit, where it will attempt rendezvous and capture. ClearSpace One will use a group of robotic arms to grab the upper stage, and then both spacecraft will be deorbited together to a lower orbit for final disintegration in the atmosphere. The mission is planned to launch in 2025 to help establish a market for in-orbit servicing and debris removal (25).

In October 2021, the UK Space Agency commissioned ClearSpace to develop a feasibility study to remove at least two UK defunct satellites. The study was successfully completed in March 2022 and a new contract was awarded to perform a second phase of the project, which will finish with the preliminary design review in 2023 of the Clearing of the LEO Environment with Active Removal (CLEAR) mission. This mission plans to remove two UK objects that have been in orbit for more than 10 years in an altitude of over 700 km, with a deorbit time longer than a hundred years (53).

### 13.3.5 Momentum

Momentum is a company founded in 2017 and based in California that operates space transportation systems that can propel or deorbit other spacecraft. Their Vigoride platform can carry satellites with masses up to 250 kg. With a wet mass of 215 kg, it can provide up to  $1.6 \text{ km s}^{-1}$  for 50 kg payload, through a water plasma propulsion system (26). Although the main objective of this system is to provide enhanced propulsive capability to their customers, the platform is suitable for active deorbiting. Momentum launched its first Vigoride transfer vehicle on May 25, 2022, and successfully deployed three satellite payloads to their respective orbits as of September 2022 (56).

### 13.3.6 D-orbit

D-orbit is a space transportation company founded in 2011 in Italy, with subsidiaries in Portugal, the United Kingdom, and the United States. It provides transportation services onboard their ION CubeSat carrier platform that can provide precision deployment and is able to host satellites from 1 to 12U. The first mission Origin released 12 SuperDove satellites for the Earth-observation company Planet, deploying the first in September 2020 with the last SuperDove deployed about a month later (34). The most recent Pulse mission finished deploying 20 satellites May 11, 2021 (35). Future versions of this technology may consider other applications such as retrieving orbiting spacecraft to deorbit them. In June 2022, D-Orbit secured a contract with ESA to improve the performance and reduce the cost of its ION transfer vehicle. Over six flights, D-Orbit has already deployed over 80 satellites successfully into their orbits (57).

In addition, D-orbit provides an external solid motor booster specifically for deorbiting purposes. This independent module, known as D-Orbit Decommissioning Device (D3) shown in figure 13.11, is a proprietary solution that is optimized for end-of-life maneuvers (27). However, it is important to note that, as compared to some other technologies in this active systems section, this technology would need to be added prior to launch.

### 13.3.7 Altius Space Machines

In 2019, the satellite constellation company OneWeb signed a partnership with Altius Space Machines from Boulder, Colorado, to include a grappling fixture on all their future launched satellites in an effort to make space more sustainable. On January 14, 2021, it was announced that the first batch of DogTags were launched into space on OneWeb satellites (36). The Altius

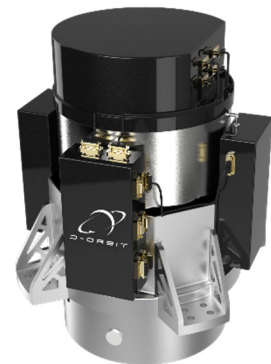
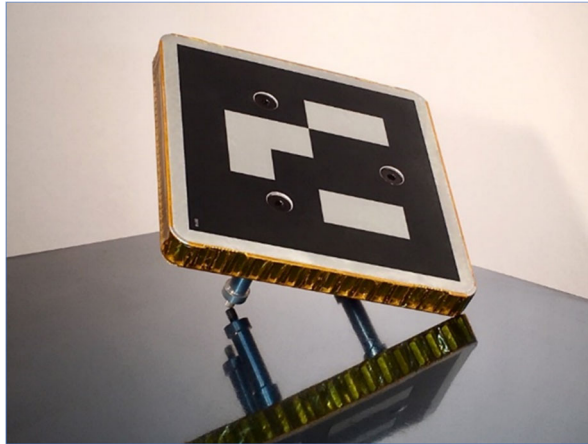


Figure 13.11: D-Orbit D3 module. Credit: D-orbit.



Bounding Volume	150mm x150mm x 65mm
Total Mass	250g
Mounting Interface	3x M5x0.8 threaded inserts on an 84.5mm bolt-hole circle
Compatible Gripping Methods	<ul style="list-style-type: none"> <li>Magnetic Capture</li> <li>Adhesive Capture <ul style="list-style-type: none"> <li>- Electrostatic</li> <li>- Gecko</li> <li>- Hot-Melt</li> </ul> </li> <li>- Chemical</li> <li>Mechanical Capture <ul style="list-style-type: none"> <li>- Pinch-Grasp</li> <li>- Snare</li> </ul> </li> <li>Penetrating Capture (Harpoon)</li> </ul>

Figure 13.12: Flight DogTags. Credits: T. Maclay, J. Goff, J.P. Sheean, and E.Han (2020).

DogTag consists of a universal interface for small satellites that is inexpensive and lightweight. The fixture design enables various grappling techniques to enable servicing or decommissioning. It uses magnetic capabilities as its primary capture mechanism but is also compatible with other techniques to accommodate other potential customers and act as a standard interface (28). More specifically, it is compatible with magnetic attraction, adhesives, mechanical, and harpooning captures. Figure 13.12 includes an image of the flight DogTags and a table of its main features. In February 2022, an ArianeSpace Soyuz launch vehicle carried 34 OneWeb satellites into orbit with corresponding Altius DogTags to mitigate future space debris. In total, over 300 DogTags have already been launched to space (50).

### 13.3.8 Other Transfer Vehicle Projects

Other companies are also developing their own the transfer vehicle technology for the LEO environment. These include UARX Space, based in Spain, which is developing its Orbit Solutions to Simplify Injection and Exploration (OSSIE) transfer vehicle. This spacecraft is designed to be modular and scalable to satisfy customer requirements by using either electric or chemical propulsion (52).

SpaceLogistics Inc., a subsidiary of Northrop Grumman announced the first flight of their Mission Robotic Vehicle (MRV) for 2024. The MRV will be aboard a SpaceX rocket and it will be equipped with a robotic arm (58).

Spaceflight Inc. has developed a complete family of transfer vehicles. The Sherpa-NG program is designed to minimize deployment times while maximizing mission assurance (59). Spaceflight Inc.'s Sherpa-LTC2 transfer vehicle was launched in September 2022 (60).

Inversion, a start-up founded in Los Angeles in 2022, plans to develop reentry capsules to bring cargo back to Earth from space. The capsules are compatible with any commercial launch vehicle, and are designed to de-orbit and land with a parachute (61). They have developed two designs, Ray and Arc, which are planned to be finalized by 2023 and 2025, respectively (62).

## 13.4 Summary

Space debris regulations are becoming more stringent. Consequently, several deorbit technologies have been matured significantly over the course of the last few years. Traditionally passive systems have been more common, have flown on various missions, and have increased to TRL 9 after successful technology demonstrations. Drag sails are the main technology for passive systems, and several companies have already commercialized and sold these products.



Other systems such as electromagnetic tethers, deployable booms, or the NASA TechEdSat series Exo-Brake have also already been prototyped and demonstrated in space, now with navigation capabilities and increased reliability. On the other hand, the investment in active systems has grown significantly. Several companies are offering transfer vehicles to remove debris or deorbit spacecraft at the end of their mission. Compatible systems to enable spacecraft rendezvous and removal are being developed in parallel as well. As an example, the RemoveDebris mission has successfully tested two different active methods, a net and a harpoon, for future implementation in active debris removal operations. Companies such as Astroscale or ClearSpace are developing missions to remove defunct satellites, and are launching precursor technology demonstration spacecraft in the initial stages of their roadmaps. In conclusion, the various deorbit technologies have seen a significant TRL increase since the last iteration of this report and the robustness of the technologies is expected to grow even further as demand for deorbiting services increases with additional launches and new regulations.

For feedback solicitation, please email: [arc-sst-soa@mail.nasa.gov](mailto:arc-sst-soa@mail.nasa.gov). Please include a business email so someone may contact you further.

## References

- (1) NASA. "Process for Limiting Orbital Debris." [Online] 2021 Available at: [standards.nasa.gov](https://standards.nasa.gov).
- (2) NASA. "NASA Orbital Debris Program Office," [Online] 2022. Available at: <https://www.orbitaldebris.jsc.nasa.gov/faq/>
- (3) NASA. "*Process for Limiting Orbital Debris*. s.l.: NASA-STD-8719.14C, 2021."
- (4) G. Bonin, et al. "*The CanX-7 Drag Sail Demonstration Mission: Enabling Environmental Stewardship for Nano- and Microsatellites*." 2013, 27th Annual AIAA/USU Conference on Small Satellites.
- (5) MMA Design. "dragNET™ De-Orbit System: *MA Design: Products*," [Online] 2020. Available at: <https://mmadesignllc.com/product/dragnet-de-orbit-system/>
- (6) C. Palla, J. Kingston, and S. Hobbs. "Development of Commercial Drag-Augmentation for Small Satellites." 7th European Conference on Space Debris ESA Space Debris Office, 2017.
- (7) R. P. Hoyt, I. M. Barnes, N. R. Voronka, and J. T. Slostadin. "*The Terminator Tape: A Cost-Effective De-Orbit Module for End-of-Life Disposal of LEO Satellites*," AIAA Space 2009 Conference.
- (8) C. Underwood et al. "*InflateSail de-orbit flight demonstration results and follow-on drag-sail applications*," s.l.: Acta Astronautica, 2019, Vols. 162, pages 344-358. ISSN: 0094-5765.
- (9) Murbach, M. , et al. "*TechEdSat 5/PhoneSat 5 (T5/P5)*," Conference on Small Satellites, 2016, Logan UT.
- (10) A. Guglielmo, et al. "*The active space debris removal mission RemoveDebris. Part 2: in orbit operations*," s.l.: Acta Astronautica, Elsevier, 2020, Vols. 168, pp. 310-322.
- (11) B. Cotten, I. Bennett, R. Zee. "*E On-Orbit Results from the CanX-7 Drag Sail Deorbit Mission*." s.l.: 131stAnnual AIAA/USUConference on Small SatellitesSSC17-X-06 , 2006.





- (12) Murbach, M., et al. "*The Exo-Brake as an Inexpensive Means of Achieving Sample Return from Low Earth Orbit – Recent Flight Tests.*" Washington, D.C.: 70th International Astronautical Congress (IAC), 2019.
- (13) G. Figliozzi. "TechEDSat-7's Flight Mission Begins." [Online] January 27, 2021. Accessed May 26, 2021. Available at: <https://www.nasa.gov/image-feature/ames/techedsat-7-s-flight-mission-begins>.
- (14) Turse, D., et al. "*Flight Testing of a Low Cost De-Orbiting Device for Small Satellites.*" Proceedings of the 42nd Aerospace Mechanisms Symposium, 2013.
- ~~(15) P. Harkness, M. McRobb, P. Lutzkendorf, R. Milligan, A. Feeney, and C. Clark. "*Development status of AEOLDOS: A deorbit module for small satellites.*" 2014.~~
- (16) R. Hoyt et al. "*The Terminator Tape: A Cost-Effective De-Orbit Module for End-of-Life Disposal of LEO Satellites.*" AIAA SPACE 2009 Conference & Exposition. 2020.
- (17) C. Henry. "Tethers Unlimited says early results of deorbit hardware test promising," . [Online] January 23, 2020. Available at: <https://spacenews.com/tethers-unlimited-says-early-results-of-deorbit-hardware-test-promising/>.
- (18) S. Omar et al. "*CubeSat Mission to Demonstrate Aerodynamically Controlled Re-Entry using the Drag De-Orbit Device (D3).*" 32nd Annual AIAA/USU Conference on Small Satellites, Logan UT, 2018.
- (19) T. Martin, S. Omar, and R. Bevilacqua. "*Controlled Spacecraft Re-Entry of a Drag De-Orbit Device (D3),*" s.l.: University of Florida, Journal of Undergraduate Research, 2019, Vol. 21.
- (20) NASA. "NASA Announces Tenth Round of Candidates for CubeSat Space Missions. [Online] March 14, 2019. Available at: <https://www.nasa.gov/feature/nasa-announces-tenth-round-of-candidates-for-cubesat-space-missions>.
- (21) Purdue University: Missions: "ADE (Aerodynamic Deorbit Experiment)." [Online] 2017. Accessed July 1, 2021. Available at: <https://engineering.purdue.edu/CubeSat/missions/ade>
- (22) C. Henry. "Iridium would pay to deorbit its 30 defunct satellites — for the right price. *Spacenews.* [Online] December 30, 2019. Available at: <https://spacenews.com/iridium-would-pay-to-deorbit-its-30-defunct-satellites-for-the-right-price/>.
- ~~(23) C. Blackerby et al. "*The ELSA-d End-of-life Debris Removal Mission: Preparing for Launch.*" 70th International Astronautical Congress (IAC), Washington D. C., 2019.~~
- ~~(24) Astroscale. "End of Life (EOL)." *Astroscale.* [Online] October 2019.~~
- (25) ClearSpace One. Find: How do we locate satellites or debris? *ClearSpace Today.* [Online] 2020. Accessed March 28, 2020. Available at: <https://clearspace.today/546-2/>.
- (26) Momentus. "Vigoride User Guide." 2020.
- (27) *Controlled Spacecraft Re-Entry of a Drag De-Orbit Device (D3).* Martin, Tanya, Omar, Sanny and Bevilacqua, Riccardo. 1, University of Florida : Journal of Undergraduate Research, 2019, Vol. 21.
- (28) T. Maclay, et al. "*The development of commercially viable ADR services: Introduction of a small-satellite grappling interface.*" s.l. : First International Orbital Debris Conference, 2019.



- (29) Astroscale Press Release. Astroscale Celebrates Successful Launch of ELSA-d. *Spacenews*. [Online] March 23, 2021. Accessed June 1, 2021. Available at: <https://astroscale.com/astroscale-celebrates-successful-launch-of-elsa-d/>
- ~~(30) Astroscale ELSA-d Launch Press Kit. 2021.~~
- (31) Astroscale Press Release. "Astroscale UK Signs £2.5 Million Agreement to Develop Space Debris Removal Technology Innovations with OneWeb." [Online] May 24, 2021. <https://astroscale.com/astroscale-uk-signs-2-5-million-agreement-to-develop-space-debris-removal-technology-innovations-with-oneweb/>
- ~~(32) J. Foust. "Momentus delays first Vigoride launch." [Online] January 7, 2021. <https://spacenews.com/momentus-delays-first-vigoride-launch/>~~
- (33) F. Tavares. "TechEDsat-10 Deploys from the Space Station." [Online] August 5, 2020. Accessed May 26, 2021. Available at: <https://www.nasa.gov/image-feature/ames/techedsat-10-deploys>.
- (34) D-Orbit. "D-Orbit announces successful ORIGIN mission." [Online] October 20, 2020. Accessed July 1, 2021. Available at: <http://spaceref.com/news/viewpr.html?pid=56501>
- (35) D-Orbit. "D-Orbit Successfully Completes Deployment Phase of Ongoing PULSE Mission, Deploys 20 Satellites In-Orbit, and Executes Orbital Maneuvers." [Online] May 18, 2021. Accessed July 1, 2021. Available at: <https://www.globenewswire.com/en/news-release/2021/05/18/2231548/0/en/D-Orbit-Successfully-Completes-Deployment-Phase-of-Ongoing-PULSE-Mission-Deploys-20-Satellites-In-Orbit-and-Executes-Orbital-Maneuvers.html>
- (36) Altius Space Machines. "Voyager Subsidiary, Altius Space Machines, Inc. Announces Successful First Orbital Launch of DogTags Aboard OneWeb's Satellites." [Online] January 14, 2021. Accessed June 28, 2021. Available at: <https://www.altius-space.com/blog/voyager-subsidiary-altius-space-machines-inc-announces-successful-first-orbital-launch-of-dogtags-aboard-onewebs-satellites/>
- (37) Vestigo Aerospace. "Vestigo Aerospace Awarded NASA Phase II SBIR." [Online] 2021. Accessed July 3, 2021. Available at: <https://www.altius-space.com/blog/voyager-subsidiary-altius-space-machines-inc-announces-successful-first-orbital-launch-of-dogtags-aboard-onewebs-satellites/>
- ~~(38) Davis, B., Tomchek, A., Turse, D., VanHalle, R., Medina, K., Francis, W., Person, C., "Planning for End of Life Satellite Disposal; The Story of a High Strain Composite Tip-Rolled De Orbit Sail", 22nd Annual AIAA/USU Conference on Small Satellites, [SSC18-XII-6, pp. 1-7], Logan, Utah, 2018~~
- (39) J. Foust. "FCC approves new orbital debris rule - SpaceNews," September 29 2022. Accessed September 29, 2022. Available at: <https://spacenews.com/fcc-approves-new-orbital-debris-rule/>
- (40) Forshaw et al. "Operational Progress Update on the ELSA-D Debris Removal Mission." 73<sup>rd</sup> Astronautical Congress, 2022.
- (41) Astroscale. "Astroscale Forges Ahead with UK Active Debris Removal Mission with Support from UK Space Agency." Accessed October 10, 2022. Available at: <https://astroscale.com/astroscale-forges-ahead-with-uk-active-debris-removal-mission-with-support-from-uk-space-agency/>
- (42) NASA. "TechEdSat mission Series." Accessed October 10, 2022. Available at: <https://www.nasa.gov/ames/techedsat> [Accessed
- (43) J. Foust. "Firefly says Alpha launch a success despite payload reentries," [Online] October 10, 2022. Accessed October 12, 2022. Available at: <https://spacenews.com/firefly-says-alpha-launch-a-success-despite-payload-reentries/>



- (44) E. Howell. "Spinnaker dragsail." [Online] September 23, 2022. Accessed October 12, 2022. Available at: <https://www.space.com/satellite-deorbiting-drag-sail-spinnaker-funding>
- (45) L. Martin. "How drag sails could help solve our space junk problem." [Online] April 11, 2022. Accessed October 12, 2022. Available at: <https://astronomy.com/news/2022/04/how-drag-sails-could-help-our-space-junk-problem>
- (46) L. Russell. "De-orbit Drag Device (D3) Successfully Placed in Orbit by NanoRacks." [Online] September 14, 2022. September 14, 2022. Available at: <https://www.satelliteevolution.com/post/de-orbit-drag-device-d3-successfully-placed-in-orbit-by-nanoracks>
- (47) A. Jones. "China deploys deorbiting 'drag sail' to aid fight against space junk." [Online] July 11, 2022. Accessed October 12, 2022. Available at: <https://www.space.com/china-deploys-drag-sail-space-junk>
- (48) M. Wall. "Astra rocket suffers catastrophic failure in 1st Florida launch, 4 satellites lost." [Online] February 10, 2022. Accessed October 12, 2022. Available at: <https://www.space.com/astra-first-florida-launch-failure-february-2022>
- (49) Voyager Space. "AltiUS Space Machines Celebrates First Successful Launch of 2022." [Online] February 16, 2022. Accessed October 12, 2022. Available at: <https://altius-space.com/first-successful-launch-of-2022/>
- (50) Astroscale. "Astroscale Selected as Contract Partner for Front-Loading Technology Study in Phase II of JAXA's Commercial Removal of Debris Demonstration Project." [Online] August 22, 2022. Accessed October 12, 2022. Available at: <https://astroscale.com/astroscale-selected-as-contract-partner-for-front-loading-technology-study-in-phase-ii-of-jaxas-commercial-removal-of-debris-demonstration-project/>
- (51) UARX Space Solutions. "Orbit Solutions to Simplify Injection and Exploration." [Online] 2022. Accessed October 12, 2022. Available at: <https://www.uarx.com/projects/ossie.php>
- (52) ClearSpace. "ClearSpace secures a major UK contract to help clean up space." [Online] September 26, 2022. Accessed October 2022. Available at: <https://clearspace.today/clearspace-secures-a-major-uk-contract-to-help-clean-up-space/>
- (53) Astroscale, ELSA-M. <https://astroscale.com/elsa-m/>
- (54) Astroscale. "ELSA-M." [Online] 2022. Accessed October 2022. Available at: <https://astroscale.com/astroscale-forges-ahead-with-uk-active-debris-removal-mission-with-support-from-uk-space-agency/>
- (55) Momentus. "Momentus First Demonstration Mission Status Update #5." [Online] September 8, 2022. Accessed October 2022. Available at: <https://investors.momentus.space/news-releases/news-release-details/momentus-first-demonstration-mission-status-update-5>
- (56) D. Werner. "D-Orbit charts ambitious course for space logistics business." [Online] June 15, 2022. Accessed October 2022. Available at: <https://spacenews.com/d-orbit-ambitions/>
- (57) S. Erwin. "Northrop Grumman to launch new satellite-servicing mission in 2024." [Online] February 21, 2022. Accessed October 2022. Available at: <https://spacenews.com/northrop-grumman-to-launch-new-satellite-servicing-mission-in-2024/>
- (58) Spaceflight, Inc. "Sherpa Program: New Orbital Transfer Vehicles Launch Smallsats to Custom Orbital Destinations." [Online] 2022. Accessed October 2022. Available at: <https://spaceflight.com/sherpa/>



- (59) J. Foust. "Sherpa tug starts raising orbit more than a month after launch." [Online] October 5, 2022. Accessed October 12, 2022. Available at: <https://spacenews.com/sherpa-tug-yet-to-start-raising-orbit-a-month-after-launch/>
- (60) S. Erwin. "Startup raises \$10 million to develop 'return vehicle' for space cargo." [Online] November 16, 2022. Accessed October 2022. Available at: <https://spacenews.com/startup-raises-10-million-to-develop-return-vehicle-for-space-cargo/>
- (61) Inversion. [Online] 2022. Accessed October 12, 2022. Available at: <https://www.inversionspace.com/>
- (62) NASA. "NASA Orbital Debris Program Office." [Online] 2022. Accessed October 20, 2022. Available at: <https://orbitaldebris.jsc.nasa.gov>
- (63) Federal Communications Commission. "Space Innovation; Mitigation of Orbital Debris in the New Space Age." September 8, 2022. Second Report and Order, IB Docket Nos. 22-271 and 18-313 <https://docs.fcc.gov/public/attachments/DOC-387024A1.pdf>
- (64) NASA. "Process for limiting orbital debris." NASA-STD-8719.14C. Available at: [https://www.nasa.gov/sites/default/files/atoms/files/process\\_for\\_limiting\\_orbital\\_debris.pdf](https://www.nasa.gov/sites/default/files/atoms/files/process_for_limiting_orbital_debris.pdf)
- (65) National Oceanic and Atmospheric Administration. "Drag Force and Solar cycle." [Online] Accessed November 1, 2022. Available at: <https://www.swpc.noaa.gov/impacts/satellite-drag>



## Summary

This report provides an extensive overview and assessment of the state-of-the-art (SoA) for small spacecraft technologies publicly available as of October 2022. The reader should be aware that the pace of SmallSat technology advancement overall is rapidly accelerating and varies per subsystem chapter. Technology maturation and miniaturization continues to expand small spacecraft capabilities with the rise in complex SmallSat mission designs. These improved capabilities have broadened the common SmallSat platform resulting in larger CubeSats and smaller SmallSats; the traditional CubeSat platforms of 1U and 3U volume now include up to 27U form factors, and SmallSats once designed as <400 kg are now <100 kg with similar capability for less cost.

While still fairly dominated by the traditional CubeSat form factor, this SoA report is starting to reflect increased interest in the more capable SmallSat platforms. The significant surge in SmallSat launch opportunities and services such as rideshares, hosted payloads, and dedicated launchers indicate the transition to a modernized SmallSat paradigm. With the rise in SmallSat accessibility and improved state-of-the-art technology, several SmallSat missions are actively working on rideshares (or dedicated rides) to destinations in years 2022-2024 that will greatly enhance the deep space presence and science data collection capabilities of SmallSats. Hosted payload services are also increasingly available for larger SmallSats and other commercial satellites that can accommodate additional instrumentation or technologies for demonstration. Dedicated launches provide rapid integration and greater mission design flexibility, allowing spacecraft designers to better dictate mission parameters, and a wide variety of integration and deployment systems are now available to facilitate access to space for small spacecraft.

This 2022 SoA edition reports specific subsystem growth with recent flight demonstrations of innovative technologies on SmallSat missions, enhanced ground station support, improved technical efficiency, emerging sensor technology, and in rideshare opportunities. The successful flights of PTD-3 and CLICK have initiated optical communication technology on spacecraft and the surplus of optical ground station networks support this shift in data collection. In development for small spacecraft, LiDAR sensor technology has applications for improved altimetry and relative navigation that can be applicable for rendezvous, docking, and formation flying. The Solid-state Architecture Batteries for Enhanced Rechargeability and Safety (SABER) project at NASA GRC is developing solid-state batteries with significantly higher energy than the current state-of-the-art lithium-ion batteries and with less hazardous qualities. There has been particular consideration on deployment mechanisms for multiple small spacecraft subsystems such as antennas booms, gravity gradient, stabilization, sensors, sails, and solar panels, and these technologies are gaining space heritage through operations. There is a spike in position, navigation, and timing technology progression in inertial sensors and atomic clocks, and magnetic navigation for near-Earth environments. In Q1 2022, NASA's Launch Services program developed a new Indefinite Delivery/Indefinite Quantity (IDIQ) mechanism: the Venture Class Acquisition of Dedicated and Rideshare (VADR) launch services with the principal purpose to accommodate very low complexity CubeSats (up to more complex Class D missions) and provide FAA licensed launch services capable of delivering payloads to a variety of orbits. The 2022 Heliophysics Small Explorers Announcement of Opportunity and Mission of Opportunity are the first to use this contract structure for upcoming launches (1).

In the past decade, CubeSats have demonstrated current state-of-the-art subsystem technology in a variety of science missions and technology demonstrations, giving the SmallSat community a realistic expectation of their advanced capabilities. The common CubeSat form factor is evolving from its initial 1U cube design to accommodate more specific and complex science missions; PocketQubes are now used more widely, and the DiskSat structure will make its debut in the next few years as an alternative to the "CubeSat" concept. The launch of Artemis I will provide a deeper



understanding of CubeSat capabilities, achievable destinations, and what the CubeSats form factor may look like in the future. Artemis I will not only expand our knowledge of the lunar surface and help provide a foundation for deep space human exploration, it will also contribute to bridging major SmallSat technology gaps, such as in-space propulsion, long distance communications, optical communications, and controlled landing on foreign surfaces. A main limiting factor in SmallSat technological advancement is carrying the necessary propellant on a CubeSat, and Artemis I is the first rocket to drop off CubeSats beyond Earth orbit thus decreasing the amount of required propellant a CubeSat will need on board for in-space propulsion and control landing beyond Earth. In addition to performing technology demonstrations, most of the Artemis I 6U payloads also have a science objective to study the Moon or perform deep space biological or space weather experiments. The continued presence of SmallSats in deep space will foster the continuation of SmallSat technology growth and available launch opportunities. This year alone, NASA launched the most CubeSat/ SmallSat missions across its Science Mission Directorate divisions and Science Technology Mission Directorate programs.

NASA is working with several American companies to deliver science and technology to the lunar surface through the Commercial Lunar Payload Services (CLPS) initiative. Under the Artemis program, these commercial deliveries present SmallSat designers with opportunities to perform science experiments, test technologies and demonstrate capabilities to help NASA explore the Moon and prepare for human missions. NASA has initially selected 14 companies to deliver payloads for NASA, including payload integration and operations and launch services to the surface of the Moon. The NASA CLPS program will begin delivering science payloads to the Moon in 2023. CLPS contracts are indefinite delivery, indefinite quantity contracts with a cumulative maximum contract value of \$2.6 billion through 2028. Companies of varying sizes can work with selected vendors and are encouraged to fly commercial payloads in addition to the NASA payloads (2).

This report will be updated annually as emerging technologies mature and become state of the art. Any current technologies that were inadvertently overlooked in this version may be included in subsequent editions. Updates to technologies listed in this report could be also modified in subsequent revisions. This report is also available online at: <https://www.nasa.gov/smallsat-institute/sst-soa>. Technology inputs, updates, or corrections can be made by reaching out to the editor of this report at [arc-sst-soa@mail.nasa.gov](mailto:arc-sst-soa@mail.nasa.gov).

## References

- (1) NASA Press Release. [Online] Jan 26, 2022. Accessed November 2022. Available at: <https://www.nasa.gov/press-release/13-companies-to-provide-venture-class-launch-services-for-nasa>
- (2) NASA. "Commercial Lunar Payload Services." [Online] July 21, 2022. Accessed November 2022. Available at: <https://www.nasa.gov/clps>



# NASA Procedural Requirements

**COMPLIANCE IS MANDATORY FOR NASA EMPLOYEES**

**NPR 7123.1C**

Effective Date: February 14,  
2020  
 Expiration Date: February 14,  
2025

[Printable Format \(PDF\)](#)

## Subject: NASA Systems Engineering Processes and Requirements (w/Change 2)

Responsible Office: Office of the Chief Engineer

| [TOC](#) | [ChangeHistory](#) | [Preface](#) | [Chapter1](#) | [Chapter2](#) | [Chapter3](#) | [Chapter4](#) | [Chapter5](#) | [Chapter6](#) | [AppendixA](#) | [AppendixB](#) | [AppendixC](#) | [AppendixD](#) | [AppendixE](#) | [AppendixF](#) | [AppendixG](#) | [AppendixH](#) | [AppendixI](#) | [AppendixJ](#) | [AppendixK](#) | [ALL](#) |

### Appendix E. Technology Readiness Levels

TRL	Definition	Hardware Description	Software Description	Success criteria
1	Basic principles observed and reported.	Scientific knowledge generated underpinning hardware technology concepts/applications.	Scientific knowledge generated underpinning basic properties of software architecture and mathematical formulation.	Peer reviewed documentation of research underlying the proposed concept/application.
Examples: <ul style="list-style-type: none"> <li>a. Initial Paper published providing representative examples of phenomenon as well as supporting equations for a concept.</li> <li>b. Conference presentations on concepts and basic observations presented within the scientific community.</li> </ul>				
2	Technology concept and/or application formulated.	Invention begins, practical application is identified but is speculative, no experimental proof or detailed analysis is available to support the conjecture.	Practical application is identified but is speculative; no experimental proof or detailed analysis is available to support the conjecture. Basic properties of algorithms, representations, and concepts defined. Basic principles coded. Experiments	Documented description of the application/concept that addresses feasibility and benefit.

			performed with synthetic data.	
Examples: Carbon nanotube composites were created for lightweight, high-strength structural materials for space structures.				
3	Analytical and experimental proof-of-concept of critical function and/or characteristics.	Research and development are initiated, including analytical and laboratory studies to validate predictions regarding the technology.	Development of limited functionality to validate critical properties and predictions using non-integrated software components.	Documented analytical/experimental results validating predictions of key parameters.
<p>Examples:</p> <ul style="list-style-type: none"> <li>a. High efficiency Gallium Arsenide solar panels for space application is conceived for use over a wide temperature range. The concept critically relies on improved welding technology for the cell assembly. Samples of solar cell assemblies are manufactured and submitted to a preliminary thermal environment test at ambient pressure for demonstrating the concept viability.</li> <li>b. A fiber optic laser gyroscope is envisioned using optical fibers for the light propagation and Sagnac Effect. The overall concept is modeled including the laser source, the optical fiber loop, and the phase shift measurement. The laser injection in the optical fiber and the detection principles are supported by dedicated experiments.</li> <li>c. In Situ Resource Utilization: Demonstrated the application of a cryofreezer for CO2 acquisition and microwave processor for water extraction from soils.</li> </ul>				
4	Component and/or breadboard validation in a laboratory environment.	A low fidelity system/component breadboard is built and operated to demonstrate basic functionality in a laboratory environment.	Key, functionality critical software components are integrated and functionally validated to establish interoperability and begin architecture development. Relevant environments defined and performance in the environment predicted.	Documented test performance demonstrating agreement with analytical predictions. Documented definition of potentially relevant environment.
<p>Examples:</p> <ul style="list-style-type: none"> <li>a. a. Fiber optic laser gyroscope: A breadboard model is built including the proposed laser diode, optical fiber and detection system. The angular velocity measurement performance is demonstrated in the laboratory for one axis rotation.</li> <li>b. b. Bi-liquid chemical propulsion engine: A breadboard of the engine is built and thrust performance is demonstrated at ambient pressure. Calculations are done to estimate</li> </ul>				



	<p>the theoretical performance in the expected environment (e.g., pressure, temperature).</p> <p>c. c. A new fuzzy logic approach to avionics is validated in a lab environment by testing the algorithms in a partially computer-based, partially bench-top component (with fiber optic gyros) demonstration in a controls lab using simulated vehicle inputs.</p> <p>d. d. Variable Specific Impulse Magnetosphere Rocket (VASIMR): 100 kW magnetoplasma engine operated 10 hours cumulative (up to 3 minutes continuous) in a laboratory vacuum chamber.</p>			
5	<p>Component and/or brassboard validated in a relevant environment.</p>	<p>A medium-fidelity component and/or brassboard, with realistic support elements, is built and operated for validation in a relevant environment so as to demonstrate overall performance in critical areas.</p>	<p>End-to-end software elements implemented and interfaced with existing systems/simulations conforming to target environment. End-to-end software system tested in relevant environment, meeting predicted performance. Operational environment performance predicted. Implementations.</p>	<p>Documented test performance demonstrating agreement with analytical predictions. Documented definition of scaling requirements. Performance predictions are made for subsequent development phases.</p>
	<p>Examples:</p> <p>a. A 6.0-meter deployable space telescope comprised of multiple petals is proposed for near infrared astronomy operating at 30K. Optical performance of individual petals in a cold environment is a critical function and is driven by material selection. A series of 1m mirrors (corresponding to a single petal) were fabricated from different materials and tested at 30K to evaluate performance and to select the final material for the telescope. Performance was extrapolated to the full-sized mirror.</p> <p>b. For a launch vehicle, TRL 5 is the level demonstrating the availability of the technology at subscale level (e.g., the fuel management is a critical function for a re-ignitable upper stage). The demonstration of the management of the propellant is achieved on the ground at a subscale level.</p> <p>c. ISS Additive Manufacturing Facility: Characterization tests compare parts and material properties of polymer specimens printed on ISS to copies printed on the ground.</p>			

6	System/sub-system model or prototype demonstration in a relevant environment.	A high-fidelity prototype of the system/subsystems that adequately addresses all critical scaling issues is built and tested in a relevant environment to demonstrate performance under critical environmental conditions.	Prototype implementations of the software demonstrated on full-scale, realistic problems. Partially integrated with existing hardware/software systems. Limited documentation available. Engineering feasibility fully demonstrated.	Documented test performance demonstrating agreement with analytical predictions.
<p>Examples:</p> <ul style="list-style-type: none"> <li>a. A remote sensing camera includes a large 3-meter telescope, a detection assembly, a cooling cabin for the detector cooling, and an electronics control unit. All elements have been demonstrated at TRL 6 except for the mirror assembly and its optical performance in orbit, which is driven by the distance between the primary and secondary mirrors needing to be stable within a fraction of a micrometer. The corresponding critical part includes the two mirrors and their supporting structure. A full-scale prototype consisting of the two mirrors and the supporting structure is built and tested in the relevant environment (e.g., including thermo-elastic distortions and launch vibrations) for demonstrating the required stability can effectively be met with the proposed design.</li> <li>b. Vacuum Pressure Integrated Suit Test (VPIST): Demonstrated the integrated performance of the Orion suit loop when integrated with human-suited test subjects in a vacuum chamber.</li> </ul>				
7	System prototype demonstration in an operational environment.	A high-fidelity prototype or engineering unit that adequately addresses all critical scaling issues is built and functions in the actual operational environment and platform (ground, airborne, or space).	Prototype software exists having all key functionality available for demonstration and test. Well integrated with operational hardware/software systems demonstrating operational feasibility. Most software bugs removed. Limited documentation available.	Documented test performance demonstrating agreement with analytical predictions.

- Examples:
- a. Mars Pathfinder Rover flight and operation on Mars as a technology demonstration for future micro-rovers based on that system design.
  - b. First flight test of a new launch vehicle, which is a performance demonstration in the operational environment. Design changes could follow as a result of the flight test.
  - c. In-space demonstration missions for technology (e.g., autonomous robotics and deep space atomic clock). Successful flight demonstration could result in use of the technology in a future operational mission
  - d. Robotic External Leak Locator (RELL): Originally flown as a technology demonstrator, the test article was subsequently put to use to help operators locate the likely spot where ammonia was leaking from the International Space Station (ISS) External Active Thermal Control System Loop B.

8	Actual system completed and "flight qualified" through test and demonstration.	The final product in its final configuration is successfully demonstrated through test and analysis for its intended operational environment and platform (ground, airborne, or space). If necessary*, life testing has been completed.	All software has been thoroughly debugged and fully integrated with all operational hardware and software systems. All user documentation, training documentation, and maintenance documentation completed. All functionality successfully demonstrated in simulated operational scenarios. Verification and Validation completed.	Documented test performance verifying analytical predictions.
---	--	---	--	---

**Note:**

\*"If necessary" refers to the need to life test either for worn out mechanisms, for temperature stability over time, and for performance over time in extreme environments. An evaluation on a case-by-case basis should be made to determine the system/systems that warrant life testing and the tests begun early in the technology development process to enable completion by TRL 8. It is preferable to have the technology life test initiated and completed at the earliest possible stage in development. Some components may require life testing on or after TRL 5.

Examples:

- a. a. The level is reached when the final product is qualified for the operational environment through test and analysis. Examples are when Cassini and Galileo were qualified, but not yet flown.

	d. b. Interim Cryo Propulsion Stage (ICPS): A Delta Cryogenic Second Stage modified to meet Space Launch System requirements for Exploration Mission-1 (EM-1). Qualified and accepted by NASA for flight on EM-1.			
9	Actual system flight proven through successful mission operations.	The final product is successfully operated in an actual mission.	All software has been thoroughly debugged and fully integrated with all operational hardware and software systems. All documentation has been completed. Sustaining software support is in place. System has been successfully operated in the operational environment.	Documented mission operational results.
Examples: <ul style="list-style-type: none"> <li>a. Flown spacecraft (e.g., Cassini, Hubble Space telescope).</li> <li>b. Technologies flown in an operational environment.</li> <li>c. Nanoracks CubeSat Deployer: Commercially developed and operated small satellite deployer on-board the ISS.</li> </ul>				

*Note: In cases of conflict between NASA directives concerning TRL definitions, NPR 7123.1 will take precedence.*

[| TOC](#) | [| ChangeHistory](#) | [| Preface](#) | [| Chapter1](#) | [| Chapter2](#) | [| Chapter3](#) | [| Chapter4](#) | [| Chapter5](#) | [| Chapter6](#) | [| AppendixA](#) | [| AppendixB](#) | [| AppendixC](#) | [| AppendixD](#) | [| AppendixE](#) | [| AppendixF](#) | [| AppendixG](#) | [| AppendixH](#) | [| AppendixI](#) | [| AppendixJ](#) | [| AppendixK](#) | [| ALL](#) |

[| NODIS Library](#) | [| Program Formulation\(7000s\)](#) | [| Search](#) |

**DISTRIBUTION:**  
**NODIS**

---

**This document does not bind the public, except as authorized by law or as incorporated into a contract. This document is uncontrolled when printed. Check the NASA Online Directives Information System (NODIS) Library to verify that this is the correct version before use: <https://nodis3.gsfc.nasa.gov>.**

---