

NASA/TM–20220018116



The Design and Development of Wind Tunnel Instrumentation

Ainsley Morgan Iwersen

December 2022

NASA STI Program ... in Profile

Since its founding, NASA has been dedicated to the advancement of aeronautics and space science. The NASA scientific and technical information (STI) program plays a key part in helping NASA maintain this important role.

The NASA STI program operates under the auspices of the Agency Chief Information Officer. It collects, organizes, provides for archiving, and disseminates NASA's STI. The NASA STI program provides access to the NTRS Registered and its public interface, the NASA Technical Reports Server, thus providing one of the largest collections of aeronautical and space science STI in the world. Results are published in both non-NASA channels and by NASA in the NASA STI Report Series, which includes the following report types:

- **TECHNICAL PUBLICATION.** Reports of completed research or a major significant phase of research that present the results of NASA Programs and include extensive data or theoretical analysis. Includes compilations of significant scientific and technical data and information deemed to be of continuing reference value. NASA counterpart of peer-reviewed formal professional papers but has less stringent limitations on manuscript length and extent of graphic presentations.
- **TECHNICAL MEMORANDUM.** Scientific and technical findings that are preliminary or of specialized interest, e.g., quick release reports, working papers, and bibliographies that contain minimal annotation. Does not contain extensive analysis.
- **CONTRACTOR REPORT.** Scientific and technical findings by NASA-sponsored contractors and grantees.

- **CONFERENCE PUBLICATION.** Collected papers from scientific and technical conferences, symposia, seminars, or other meetings sponsored or co-sponsored by NASA.
- **SPECIAL PUBLICATION.** Scientific, technical, or historical information from NASA programs, projects, and missions, often concerned with subjects having substantial public interest.
- **TECHNICAL TRANSLATION.** English-language translations of foreign scientific and technical material pertinent to NASA's mission.

Specialized services also include organizing and publishing research results, distributing specialized research announcements and feeds, providing information desk and personal search support, and enabling data exchange services.

For more information about the NASA STI program, see the following:

- Access the NASA STI program home page at <http://www.sti.nasa.gov>
- E-mail your question to help@sti.nasa.gov
- Phone the NASA STI Information Desk at 757-864-9658
- Write to:
NASA STI Information Desk
Mail Stop 148
NASA Langley Research Center
Hampton, VA 23681-2199

NASA/TM–20220018116



The Design and Development of Wind Tunnel Instrumentation

*Ainsley Morgan Iwersen (Intern)
Boise State University, Boise, ID
Goddard Space Flight Center, Greenbelt, MD*

National Aeronautics and
Space Administration

Goddard Space Flight Center
Greenbelt, Maryland 20771

December 2022

Trade names and trademarks are used in this report for identification only. Their usage does not constitute an official endorsement, either expressed or implied, by the National Aeronautics and Space Administration.

Level of Review: This material has been technically reviewed by technical management.

The Design and Development of Wind Tunnel Instrumentation

Ainsley Iwersen

Boise State University, Boise, Idaho 83725

This report presents the work at NASA Wallops Flight Facility in the Balloon Research and Development Lab completed over the Fall of 2022. All three projects this past cycle were focused on designing, developing, and implementing wind tunnel instrumentation into an X-Stream Wind Tunnel. The first project, the Load Cell Project, focused on implementing a 3-axis Interface Load Cell into the test section of the wind tunnel. In addition to this, a load cell mount adapter was designed to connect the sting to the load cell, in order to measure the loads placed on the object being tested. The majority of this project was completed by the previous Summer 2022 BRDL intern; however, this semester focused on implementing the previous intern's design in the wind tunnel, along with designing and developing the load cell adapter. The next project, NEWTSS (Navigational Electrical Wind Tunnel Stepper System), focused on designing and developing a linear stage to move a Pitot tube vertically within the wind tunnel test section. The purpose was to create a way to ensure measurements could be taken at any point on the y-axis of the wind tunnel when testing. The third project was to take propeller design parameters, draw a 2-blade propeller in CAD according to those parameters, 3D print the propeller, and test the model using a Dynamometer Series 1580 thrust stand. Overall, this internship provided an opportunity to work on end-to-end projects, in addition to an opportunity to design, source materials, and increase CAD and programming skills.

Table of Contents

0.0 List of Acrostics	4
1.0 Load Cell Project	4
1.1 Overall Design/Configuration	5
Figure 1: Load Cell Mount	5
1.2 Mounting Plate	6
Figure 4: Mounting Plate CAD Model	6
1.3 Load Cell Adapter	6
Figure 5: Load Cell Adapter	7
Figure 6: Final Load Cell Adapter Design	7
1.4 Programming	7
Equation 1: Voltage to Wind Speed Conversion	8
1.5 Wiring	8
Figure 7: Load Cell Configuration Diagram	9
2.0 NEWTSS	9
2.1 NEWTSS Overall Design	9
Figure 8: NEWTSS CAD Assembly	9
Figure 9: NEWTSS Assembled in Wind Tunnel	10
2.2 Mechanical Components	10
2.2.1 Stepper Motor	10
Equation 2: Needed Holding Torque Calculations	11
2.2.2 Pinion	11
Figure 10: Stepper Motor and Pinion	11
Figure 11: Stainless Steel Pinion	11
2.2.3 L-Bracket	11
Figure 12: L-Bracket CAD Model	12
2.2.4 Roller	12
Figure 13: Roller CAD Model	12
2.2.5 Holding Bracket	12
Figure 14: Holding Bracket	13
2.2.6 Gear Rack	13
Figure 15: Brass Gear Rack CAD Model	13
2.2.7 Clips	13
Figure 16: Clip CAD Model	14
2.2.8 Platform	14
Figure 17: Platform	14
2.3 Electronics	14
2.3.1 Programming	14
Figure 18: Arduino Serial Monitor Interface	15
2.3.2 Wiring	15
Figure 20: NEWTSS Wiring Diagram	16
3.0 Propeller Project	16
Figure 21: Dynamometer Series 1580 Thrust Stand and Enclosure	16
3.1 Drawing the Propellers in CAD	17
Figure 22: 2-Blade NACA 0015 Propeller CAD Model	17
Figure 23: Airfoil Plotter Tool	18
3.2 Printing the Propellers	18
Figure 24: NACA 0015 3D Printed Propellers	19
4.0 Conclusion	19
5.0 References	19

0.0 List of Acrostics

Acrostic

BPO
BRDL
CAD
DAQ
NASA
NEWTSS
WFF

Definition

Balloon Program Office
Balloon Research and Development Lab
Computer-Aided Design
Data Acquisition
National Aeronautics and Space Administration
Navigational Electrical Wind Tunnel Stepper System
Wallops Flight Facility

1.0 Load Cell Project

A load cell mount was designed, modeled and fabricated in order to create a way to attach a 3-axis Interface Load Cell to a wind tunnel test section. This was to test the loads in the x-, y-, and z-axes imposed by various wind speeds on 3D-printed models of both partially and fully inflated balloons. The data from these tests will aid in better understanding the movement and trajectories of NASA's Super Pressure Balloons. In the following sections, the overall design of the Load Cell Mount will be discussed and shown, in addition to the design of an adapter needed to attach the Interface Load Cell to the sting which holds the 3D-printed balloon models.

In addition to the design of the Load Cell Mount and Load Cell Adapter, the entirety of the mount needed assembling within the wind tunnel test section, and a program in LabVIEW was created to read and display the loads applied on each of the 3D printed models.

1.1 Overall Design/Configuration

The load cell mount was designed to attach a load cell to a wind tunnel to measure loads on 3D-printed models of both partially and fully inflated balloons. The load cell mount attaches to the bottom Lexan panel of the wind tunnel using (4) Black-Oxide Alloy Steel Hex Drive Flat Head Screws, (4) Aluminum Unthreaded Spacers, and (4) 8-32 Thread Size Low-Strength Steel Hex Nuts. The sting, the rod that attaches to the Interface Load Cell through a load cell adapter, will be further discussed in **Section 1.3**.

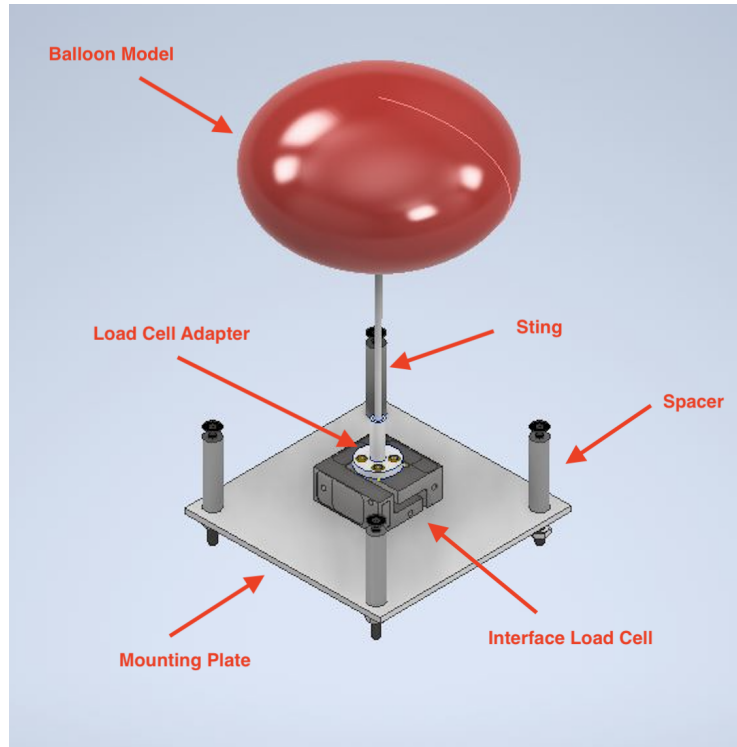

Figure 1: Load Cell Mount

Figure 1 depicts the assembled Load Cell Mount attached to the wind tunnel test section's bottom Lexan panel in Inventor AutoDesk.

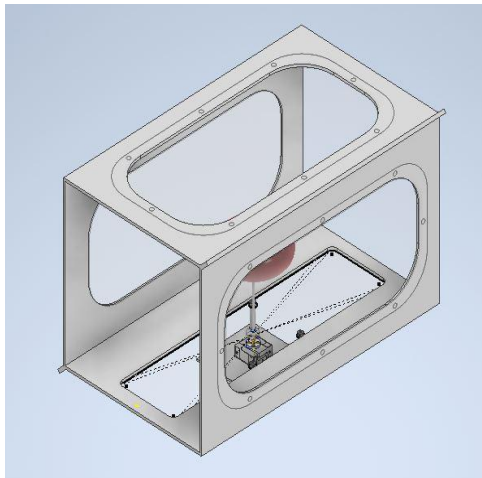

Figure 2a

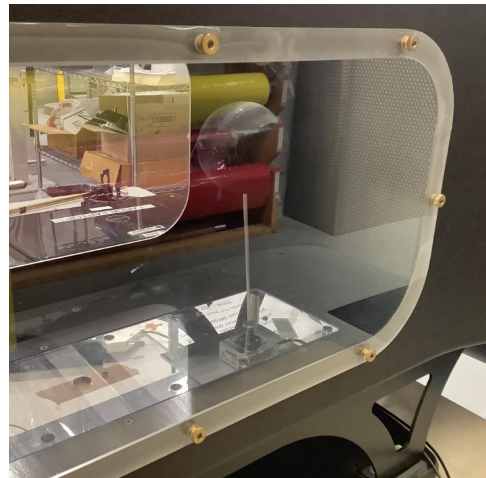

Figure 2b

Figure 2: Load Cell Mounted Inside Wind Tunnel

1.2 Mounting Plate

After a review of the previous Load Cell Mount design, Dr. Christopher Yoder determined the plate could be reduced from a thickness of 3/8th to 1/8th. The mounting plate is composed of Aluminum 6061 and is 4.72 inches in width, and 4.72 inches in length.

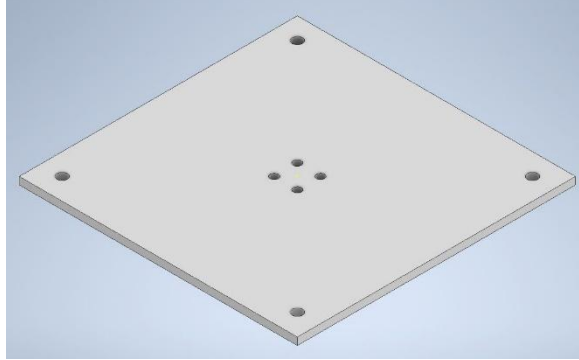

Figure 4: Mounting Plate CAD Model

1.3 Load Cell Adapter

The original load cell mount adapter was composed of PLA (Polylactic Acid) filament and 3D printed, with a barbed brass insert placed within the center hole. This would allow a threaded rod to screw into the insert. After printing a handful of the load cell mount adapters, the adapter was deemed too unstable as a 3D print and for testing objects in the wind tunnel. The most significant issue encountered was when screwing the object to be tested onto the sting rod. The bottom of the rod would become unscrewed from the barbed insert, or the barbed insert would become unattached from the center hole of the adapter. Because of this, the rod being utilized as the sting became unstable after the object to be tested was put in place. The 1/8th inch sting was also deemed too unstable after breaking within the wind tunnel test section when being screwed in place.

As a result of these aforementioned issues, the final adapter was composed of Aluminum 6061, and instead of using a barbed insert, the center hole was threaded with a 10-24 thread. The center hole was also widened to accommodate a wider and increasingly stable 3/16th inch diameter sting. Many of the fillets were also taken out in the final design to make it easier to machine. The adapter's design essentially stayed the same; however, the material was changed to increase stability.



Figure 5: Load Cell Adapter

Figure 5 depicts the original 3D printed load cell adapter attached to the 3-axis Interface Load Cell

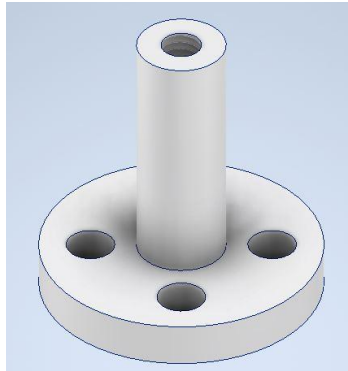

Figure 6: Final Load Cell Adapter Design

1.4 Programming

The Load Cell LabVIEW VI is the basis for every piece of wind tunnel instrumentation that must be programmed to function within the wind tunnel. This is done to ensure that all instrumentation can be run off the same program and computer, instead of needing multiple programs and applications to be run at the same time.

The LabVIEW VI is capable of reading loads from each axis of the 3-axis Interface Load Cell, graphing said loads, and graphing the wind speed of the tunnel on a separate plot. The following is also printed onto a CSV file and saved: date and time the data was taken, voltage, wind speed, and corresponding loads on the x-,y-, and z-axes. The wind speed is calculated within the LabVIEW VI by converting the voltage from the pressure transducer into pressure, which is then square rooted to result in wind speed. This equation was formulated from Bernoulli’s Equation and is shown below in **Equation 1**. The component being multiplied by 0.2 at the beginning of the equation is the voltage from the NI-DAQmx 6001. A NI-DAQmx 6001 was also utilized to aid in reading loads from the load cell. As a result, the Data Acquisition (DAQ) Assistant feature was used to implement the NI-DAQmx 6001 into the overall VI, replacing the need to manually create that specific portion of the VI.

$$\begin{aligned}
 V &= \text{voltage} \\
 (V)(0.2) &= x \\
 (x)(249) &= b \\
 (b)(2) &= r \\
 \sqrt{r/1.225} &= \text{Wind speed}
 \end{aligned}$$

Equation 1: Voltage to Wind Speed Conversion

1.5 Wiring

The load cell must connect to an Amplifier in order to amplify the voltage for it to be readable, after which the voltage will travel to NI-DAQmx 6001. Cable 1 is used to provide power to the Amplifier, while Cable 2 is used to connect the load cell to the Amplifier using a 37-pin DSUB connector. Cable 3 utilizes a 15-pin DSUB which connects to the opposite end of the Amplifier. However, the other end of Cable 3 is open with 20 wires protruding from the end. A multimeter was utilized in order to determine which wires connected to which pins on the 15-pin DSUB. After this, the 3A40 3-Axis Load Cell datasheet was used to determine which wire was required to connect with each channel on the NI-DAQmx 6001. The correctly matched wires and channels are shown in **Figure 7**.

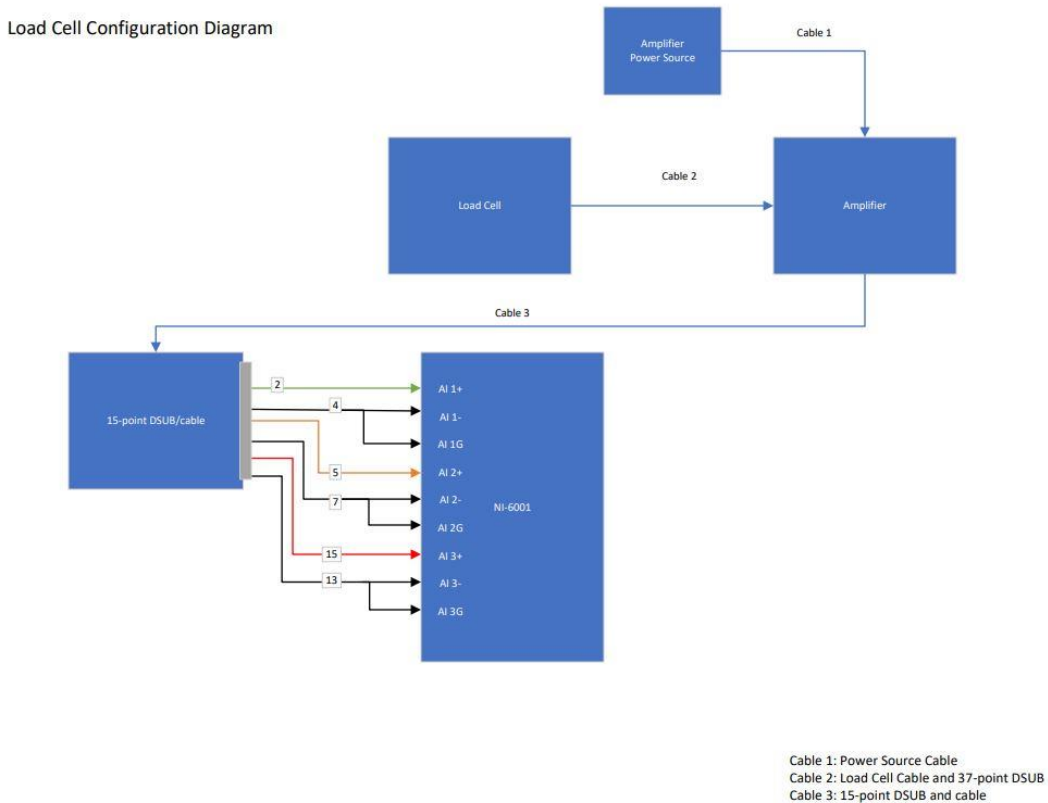

Figure 7: Load Cell Configuration Diagram

2.0 NEWTSS

The purpose of NEWTSS (Navigational Electrical Wind Tunnel Stepper System) is to enable the vertical movement of a Pitot tube within a wind tunnel test section, in order to take measurements more efficiently during the testing of 3D printed partially and fully inflated balloon models. NEWTSS is electronically powered and utilizes user input and LabVIEW to move to certain locations within the wind tunnel test section. The following sections will describe the overall design and function of NEWTSS, each 3D printed component, and its use, along with how the LabVIEW VI and Arduino were utilized and implemented.

2.1 NEWTSS Overall Design

NEWTSS is based on the concept of a rack and pinion system, in which the pinion is able to drive the rack up and down within the wind tunnel test section. The pinion turns through the use of a NEMA 11 stepper motor, which is driven by a DRV8834 stepper motor driver, an Arduino Mega board, and LabVIEW. Two 3D-printed components, the Roller and the Holding Bracket, are used to stabilize the pinion, gear rack, and Pitot tube. The gear rack is attached to the Pitot tube through the use of (2) 3D printed clips, along with (2) 2-56 Thread Size, $\frac{3}{8}$ " long, 18-8 Stainless Steel Socket Head Screws, and (2) 18-8 Stainless Steel Narrow Hex Nuts. An overall platform is used to place all the components on and provide a space to add any additional components if desired or needed. Each component is shown labeled below in **Figure 8**. NEWTSS was successfully implemented into the wind tunnel test section, as shown in **Figure 9**.

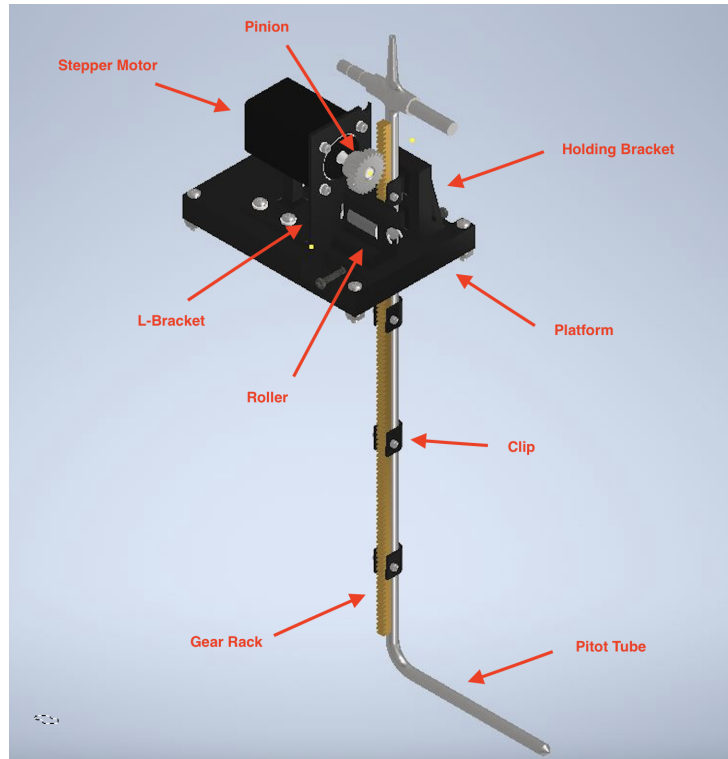

Figure 8: NEWTSS CAD Assembly

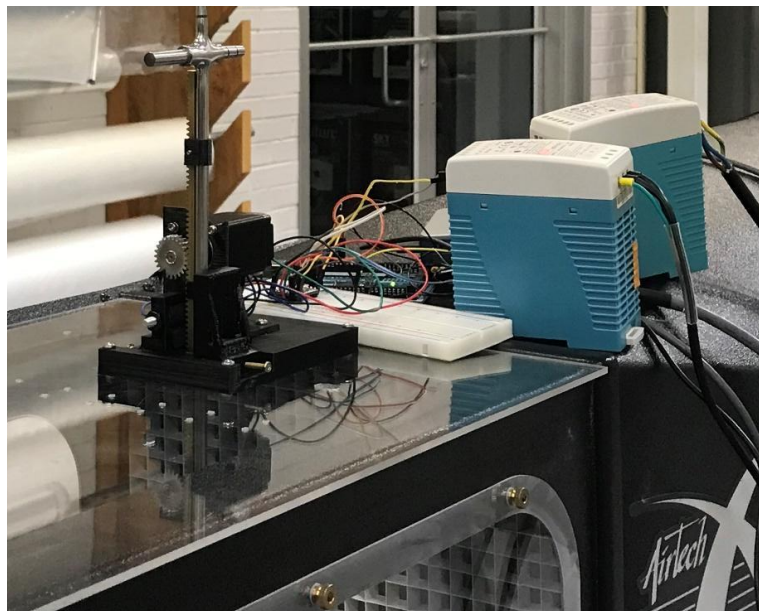

Figure 9: NEWTSS Assembled in Wind Tunnel

Figure 9 depicts NEWTSS implemented and assembled within the wind tunnel test section. Two variable power sources are also shown, one to power the NI-DAQ 6001 and one to power the stepper motor.

2.2 Mechanical Components

2.2.1 Stepper Motor

A NEMA 11-size hybrid bipolar stepper motor was used for this design due to the required torque, the calculations for which are shown below in **Equation 2**, with a safety factor of 3. The stepper motor has a step angle of 1.8 degrees (200 steps/revolution), and a holding torque of 950 g-cm (Pololu - Stepper Motor). The motor is fastened to the L-Bracket using (4) M2.5x0.45 mm, 4 mm long, 18-8 Stainless Steel Socket Head Screws, and (4) 18-8 Stainless Steel Washers.

$$m_{rack} = \text{mass of gear rack}$$

$$m_{pitot} = \text{mass of Pitot tube}$$

$$T_m = \text{needed holding torque}$$

$$m_{rack} = 0.044 \text{ kg}$$

$$m_{pitot} = 0.122 \text{ kg}$$

$$F = mg$$

$$F = (0.122 + 0.044)(9.81)$$

$$F = 1.62846 \text{ N}$$

$$r = \text{pinion pitch radius} + \text{gear rack pitch height} + \text{pitot tube radius}$$

$$r = 0.375 + 0.157 + 0.119 + 0.055$$

$$r = 0.0179324$$

$$T_m = rF$$

$$T_m = (0.0179324 \text{ m})(1.62846 \text{ N})$$

$$T_m = 0.0292 \text{ Nm} = 29.2 \text{ mNm}$$

$$\text{Required torque with safety factor of 3} = (29.2)(3) = 87.6 \text{ Nm}$$

$$\text{Final torque needed} = 87.6 \text{ Nm}$$

Equation 2: Needed Holding Torque Calculations

2.2.2 Pinion

The design utilizes a pinion composed of 303 Stainless Steel with a set screw, round bore, 32 pitch, and 24 teeth. The inner diameter of the pinion is 0.25", the pitch diameter is 0.75", and the outer diameter is 0.81". The face width is 3/16". The pinion can be seen press-fit onto the stepper motor in **Figure 10**, and the CAD model of the pinion can be seen in **Figure 11**.

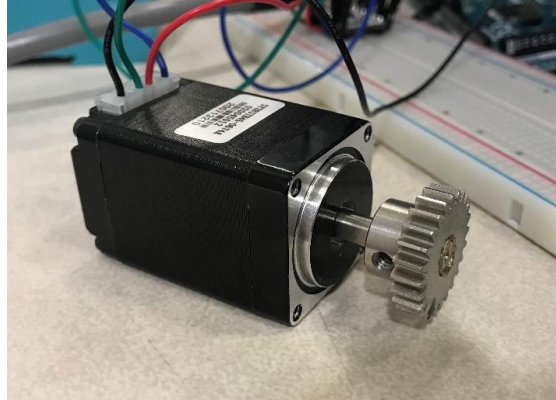

Figure 10: Stepper Motor and Pinion



Figure 11: Stainless Steel Pinion

2.2.3 L-Bracket

The L-Bracket is used to hold the stepper motor in place and is mounted to the platform. The L-Bracket is composed of PLA and is 3D printed. The L-Bracket is shown below in **Figure 12**.

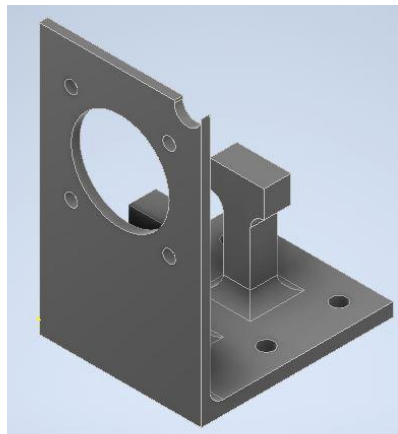

Figure 12: L-Bracket CAD Model

2.2.4 Roller

The Roller was designed and developed to press onto the gear rack, and when combined with the Holding Bracket (described below), puts enough pressure on the gear rack and Pitot tube to keep both in place. The Roller was designed to attach to and detach from the platform for ease of assembly and disassembly. The Roller slides in place on the Platform and is driven further forward laterally using a hex head screw which is press-fit into the part and is shown below in **Figure 13**. A hex nut is attached to the Roller and as the user turns the screw, the hex nut causes the Roller to move. Increased pressure can be placed on the gear rack by turning the screw clockwise, and released by turning the screw counterclockwise.

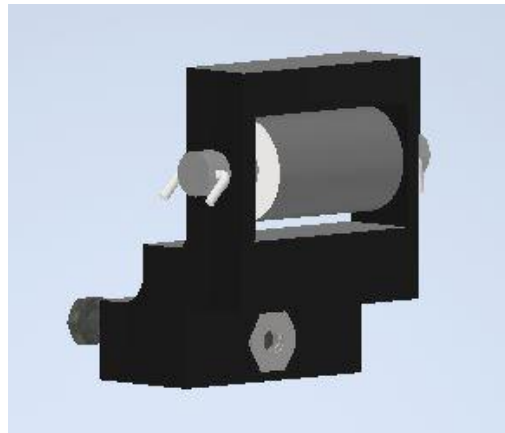

Figure 13: Roller CAD Model

2.2.5 Holding Bracket

The Holding Bracket was designed similarly to the Roller, utilizing a hex head screw and hex nut as described in **Section 2.2.4**. The Holding Bracket has two U-shaped features, which can be seen in **Figure 14**, that are designed for the Pitot tube to slide through when changing position within the wind tunnel. These U-shaped features also apply enough friction onto the Pitot tube to prevent any slipping, and the lateral sliding motion caused by the hex head screw and hex nut allows the Holding Bracket to apply enough pressure onto the Pitot tube in order to keep it in place with the gear rack. Utilizing both the Roller and the Holding Bracket, a sufficient amount of pressure is placed on the Pitot tube and the gear rack at the same time in order to prevent both from falling through the square-shaped hole in the Platform. The Holding Bracket is composed of PLA and is 3D printed.

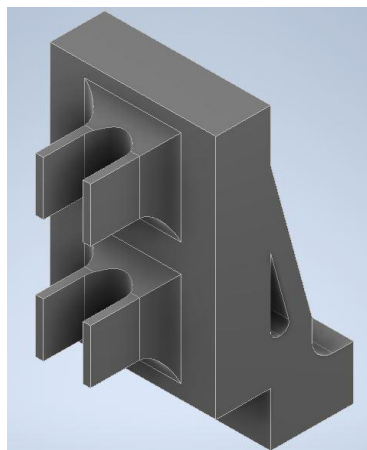

Figure 14: Holding Bracket

2.2.6 Gear Rack

The brass gear rack is rectangular, with a 32 pitch and pressure angle of 20 degrees. The gear rack is pictured below in **Figure 15**. The gear rack had four holes drilled into it, each approximately 2.6 inches apart. Each of these holes held a 3D-printed clip and was used to connect the gear rack to the Pitot tube. Only the two outer holes ended up being used, as the two inner clips got stuck on the Roller and Holding Bracket.

There was some initial concern about using two different types of metals, with the pinion being made of stainless steel and the gear rack being made of brass; however, because the pinion requires a minimal amount of force to lift the gear rack and Pitot tube, it was deemed non-concerning to use the two different types of materials.



Figure 15: Brass Gear Rack CAD Model

2.2.7 Clips

The clips are designed to attach the Pitot tube to the gear rack. An adhesive was not used as it was desired for the gear rack to be detached from the Pitot tube if necessary. The clips are press fit onto the Pitot tube and gear rack, with a small bolt that is slid through the hole in the clip, as shown in **Figure 16**, and a hole in the gear rack. The bolt is secured with a hex nut to prevent slippage. The clips are 0.54 inches in length, 0.35 inches in width, and 0.50 inches in height. The clips are composed of PLA and are 3D printed.



Figure 16: Clip CAD Model

2.2.8 Platform

The platform is used to hold all components of the design. The platform is approximately 4 inches in length, 2.7 inches in width, and 0.5 inches in height. There is a small square cut-out near the front of the design which allows the gear rack and Pitot tube to slide up and down. The square cut-out is 0.55 inches in length, 0.55 inches in width, and 0.5 inches in height. The platform is composed of PLA and is 3D printed.

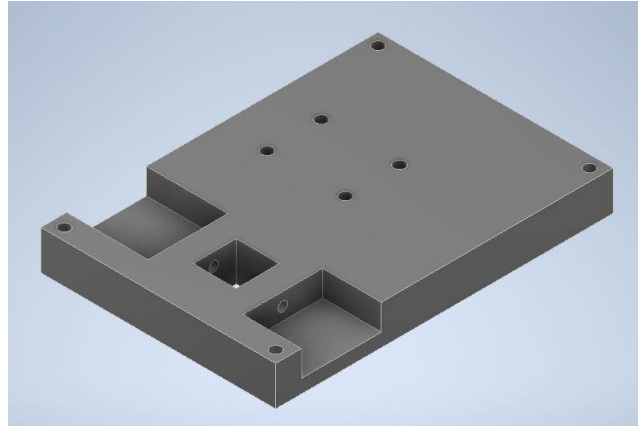

Figure 17: Platform

2.3 Electronics

2.3.1 Programming

When originally programming the stepper motor, Arduino was solely used. For testing purposes and becoming familiar with programming in Arduino, a program was created in which the user would input a specific number of steps, and the stepper would move that number of steps. To move the Pitot tube in a downward direction, the user would input a positive number in order to move the pinion in a clockwise direction. To move the Pitot tube in an upward direction, the user would input a negative number in order to move the pinion in a counterclockwise direction. This interface with the serial monitor is shown in **Figure 18**.

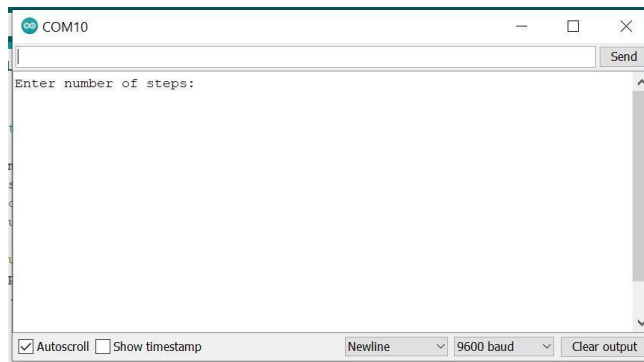

Figure 18: Arduino Serial Monitor Interface

Ultimately, a combination of LabVIEW and Arduino was used to control the movement of the stepper motor, and therefore the vertical motion of the Pitot tube, as the wind tunnel is controlled through LabVIEW. In order to ensure the stepper motor moved to the desired position within the wind tunnel test section, LabVIEW was used to send an analog voltage output to a NI-DAQmx 6001, which is connected to an Arduino Mega board. Another program was

created within Arduino IDE to read this analog voltage output, convert the voltage to a position, and set the speed of the stepper motor. This program was uploaded to the Arduino Mega board, as the board is able to hold code even when not connected to a computer. Within the LabVIEW VI, the user is able to input a new position in terms of percentage for the Pitot tube to move to within the wind tunnel. As a reference for the user, the top of the wind tunnel is considered 0 percent, and the bottom of the wind tunnel is considered to be 100 percent. The user can move anywhere between these two points by utilizing the interface, which is shown in **Figure 19**.

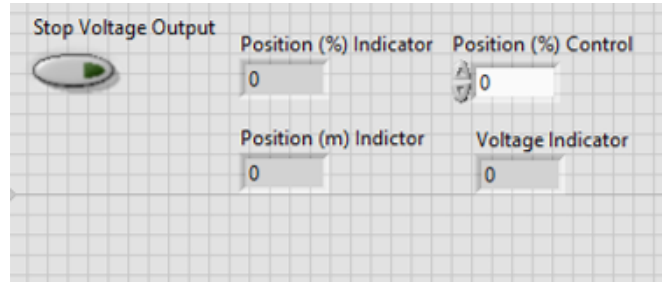

Figure 19: LabVIEW Stepper Motor Position User Interface

2.3.2 Wiring

The wiring diagram for NEWTSS is shown below in **Figure 20**. The Arduino Mega is powered by a 5 V variable power source and the stepper motor is powered through a 12 V variable power source which is wired into the stepper motor driver. The stepper motor required 0.67 Amps per phase, which exceeded the 0.05 Amps that the Arduino Mega board is able to handle (Pololu - Stepper Motor). As a result, a DRV8834 stepper motor driver was used as it is able to handle a maximum of 2 Amps per phase (Pololu - DRV8834). Due to the fact that an analog voltage output from the Arduino Mega to the NI-DAQmx 6001 was used to control how many steps the stepper motor moved, the Arduino Mega was connected to the ai0 channel on the NI-DAQmx 6001, as shown in **Figure 20**.

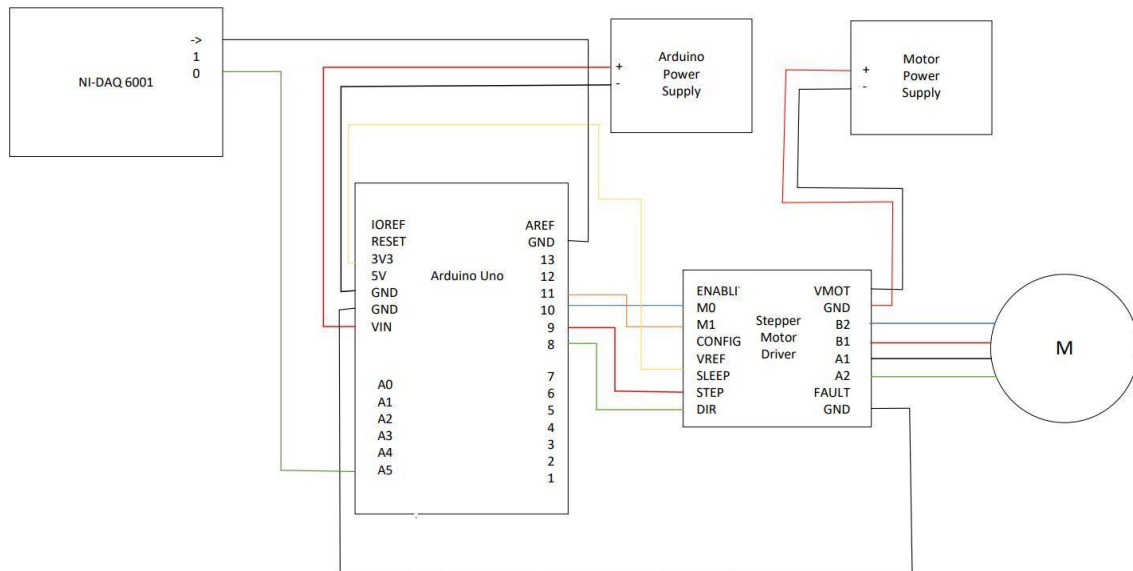

Figure 20: NEWTSS Wiring Diagram

3.0 Propeller Project

The purpose of testing the propellers is to test various designs of low Reynolds number propeller geometries and optimize those designs for low-power high thrust applications on scientific balloons. Before testing of the propellers could begin, the Dynamometer Series 1580/1585 thrust stand needed to be assembled, along with sourcing an ESC and brushless DC motor that was compatible with said thrust stand, as pictured below.

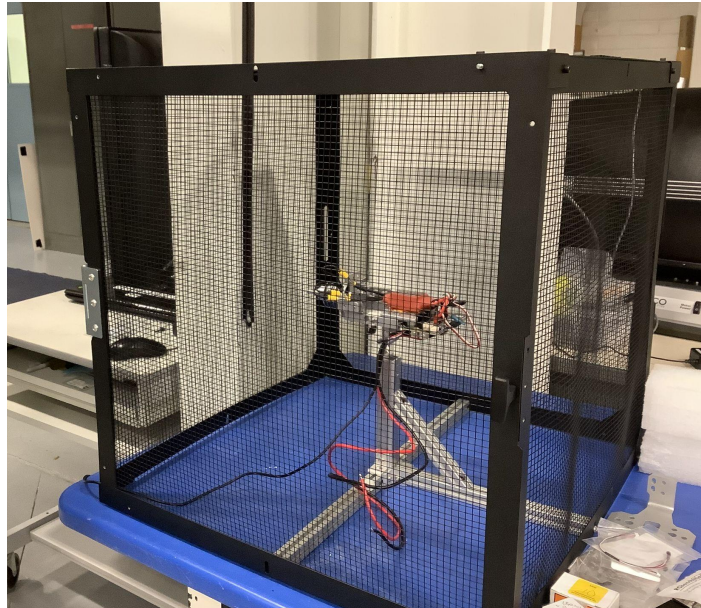

Figure 21: Dynamometer Series 1580 Thrust Stand and Enclosure

3.1 Drawing the Propellers in CAD

The following set of parameters were followed when drawing the first propeller in Inventor AutoDesk.

1. Utilize NACA 0015 airfoil
2. Adapt to a motor shaft of 3.17 mm
3. 2-blade propeller
4. CCW rotation
5. Airfoil chord: 0.7 in
6. Maximum overall diameter: 7.0 in
7. Propeller blade span: 3.0 in
8. Root Pitch Angle: 7 degrees
9. Tip Pitch Angle: 2 degrees
10. Linear transition from root to tip

To create the airfoils needed for the CAD model, the Airfoil Plotter tool through airfoiltools.com was utilized and the points were exported to a Microsoft Excel file. These points were then imported into Inventor AutoDesk and an airfoil was created with those points within CAD. Within the Airfoil Plotter tool, the Pitch angle was able to be specified in degrees. Utilizing this feature, one airfoil with a pitch angle of 7 degrees and another with a pitch angle of 2 degrees were created. After importing these to Inventor, they were blended together to create a propeller blade, as shown in **Figure 22**.

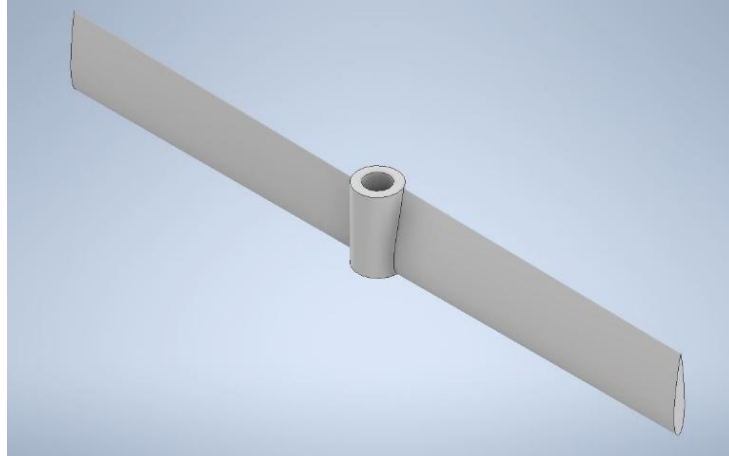

Figure 22: 2-Blade NACA 0015 Propeller CAD Model

Name = NACA 0015
 Chord = 17.78mm Radius = 0mm Thickness = 100% Origin = 0% Pitch = 2°

[Open full size plan in new window](#) [Open paginated plan in new window for multi page printing](#)
[CSV file of coordinates](#) [SVG image as text file](#)
[Restore defaults](#) [Download PDF file](#)

Airfoil	naca0015-ii - NACA 0015	Choose from database list or add you own airfoils here
Chord (mm)	17.78	Chord width in millimetres. (1 inch = 25.40mm)
Radius (mm)	0	Radius of camber in millimetres. Zero for no curve
Thickness (%)	100	Thickness adjustment. 100% is normal thickness. 50% is half. 200% is double
Origin (%)	0	Adjust the position of the origin e.g. 50% is mid chord
Pitch (degrees)	2	Pitch or angle of attack. 180 flips the plot
Halo (mm)	0	Line parallel to airfoil for wing covering or jig. Negative values are external, positive internal.
Halo (mm)	0	Second line parallel to airfoil as above
Colour	Colour	Colour palette or black & white
Line thickness (%)	100	Scale the line thickness (10% to 500%)
Reverse	<input type="checkbox"/>	Plot a mirror image
Data box	<input checked="" type="checkbox"/>	Print the airfoil data on the image
Camber line	<input type="checkbox"/>	Show camber line on image
X grid (mm)	10	X grid size in millimetres
Y grid (mm)	10	Y grid size in millimetres
Paper width (mm)	280	Used for printing plan. A4 landscape approx 280mm
Paper height (mm)	180	Used for printing plan. A4 landscape approx 180mm
<input type="button" value="Plot"/>		

Figure 23: Airfoil Plotter Tool

3.2 Printing the Propellers

It was desired for the 3D printed propellers to be smoothly finished to ensure the most accurate data could be gleaned from them when testing. However, the first few prints proved to be rough and unsuitable for testing. The propellers were printed vertically, as shown in **Figure 22**, and were originally printed with no support. It was found that printing the propellers with a raft was the best solution as it prevented any rough finish from occurring on the bottom of the propeller. I began with printing a 2-blade propeller that utilized a NACA 0015 airfoil. The four print attempts, among which is the final successful print, are shown below in **Figure 24**.



Figure 24: NACA 0015 3D Printed Propellers

4.0 Conclusion

As the Fall 2022 internship comes to an end, there are still aspects of each of these projects that need to be completed, which the Spring 2023 intern will be tasked with. Regarding the Load Cell Project, the use of the Load Cell Mount in the testing of 3D printed models of both partially and fully inflated balloons will be continued. Regarding NEWETSS, the tasks will mainly consist of refining the system. These tasks will include implementing limit switches within the wind tunnel to accurately pinpoint the position of the Pitot tube within the wind tunnel, in addition to bringing the electronics out of the prototyping phase by soldering the components together. The Spring 2023 intern will also be responsible for creating a way to mount the electronics in an organized fashion to the top of the wind tunnel test section. As the Propeller Project was recently started, and now that the set-up of the project has been completed, propellers will continue to be drawn up in CAD based on data and parameters provided by Dr. Christopher Yoder. The propellers will also continue to be 3D printed and tested using the Dynamometer Series 1580 thrust stand.

5.0 References

Yoder, Dr. C. (2022, August 22-November 29). Personal communication [Personal interview]

Load Cell / BSC4 Analog Bridge Amplifier Calibration Certificate, certificate, Interface Force Measurement Solutions, viewed 13 October 2022

Force Transducer Calibration Certificate 3-Axis Load Cell, certificate, Interface Force Measurement Solutions, viewed 14 October 2022

3A40 3-Axis Load Cell, electronic datasheet, Interface Force Measurement Solutions, viewed 14 October 2022, <www.interfaceforce.com/wp-content/uploads/3A40-1.pdf>

Pololu Robotics & Electronics. (n.d.). *Pololu - Stepper Motor: Bipolar, 200 steps/REV, 28×45mm, 4.5V, 0.67 A/phase*. Pololu Robotics & Electronics. Retrieved October 15, 2022, from <https://www.pololu.com/product/1206/specs>

Pololu Robotics & Electronics. (n.d.). *Pololu - DRV8834 low-voltage stepper motor driver carrier*. Pololu Robotics & Electronics. Retrieved October 16, 2022, from <https://www.pololu.com/product/2134>