

Acoustic Liners

(with a few OSU connections)

Michael Jones

NASA Langley Research Center

Oklahoma State University, April 26, 2013

Outline



- **Background**
- **Demo**
- **Extended and Local-Reacting Liners**
- **Acoustic Impedance**
- **NASA Liner Evaluation Tools**
- **Novel Applications and Concepts**
- **NASA Opportunities**

Background



Aircraft Engine Nacelle

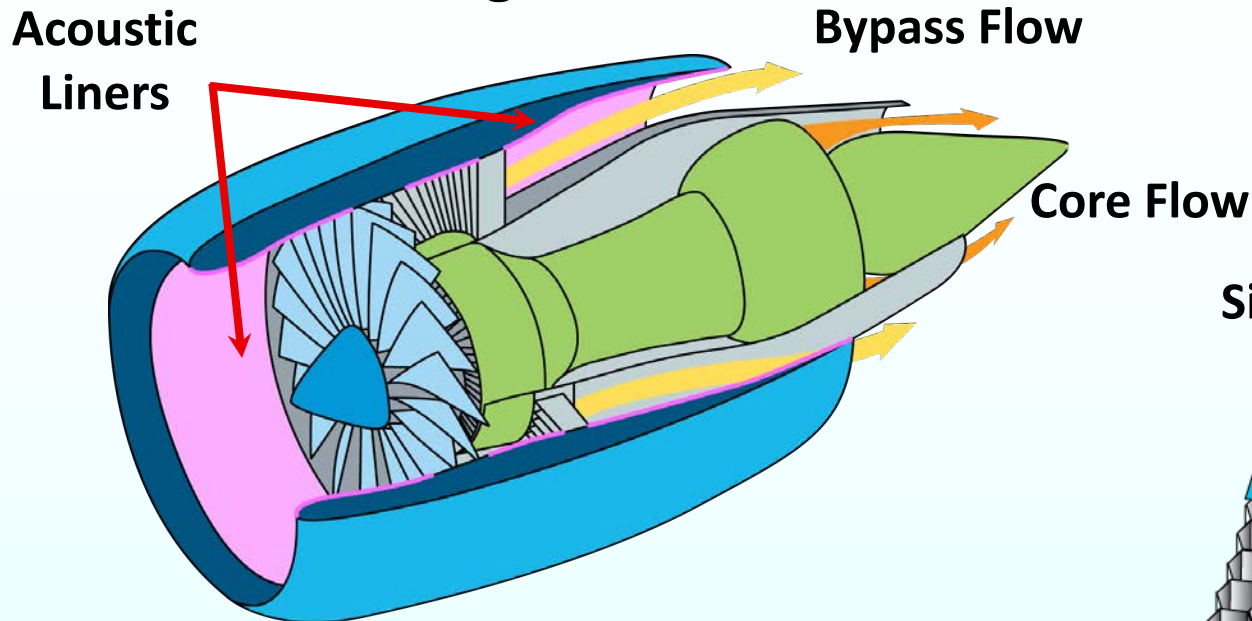

Single Layer Liner

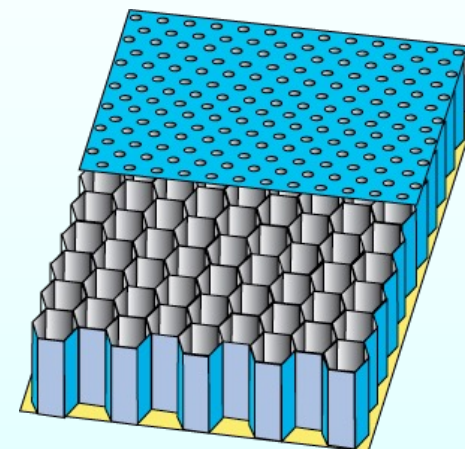

(a bit more than just a hole in the wall)

Tiltduct

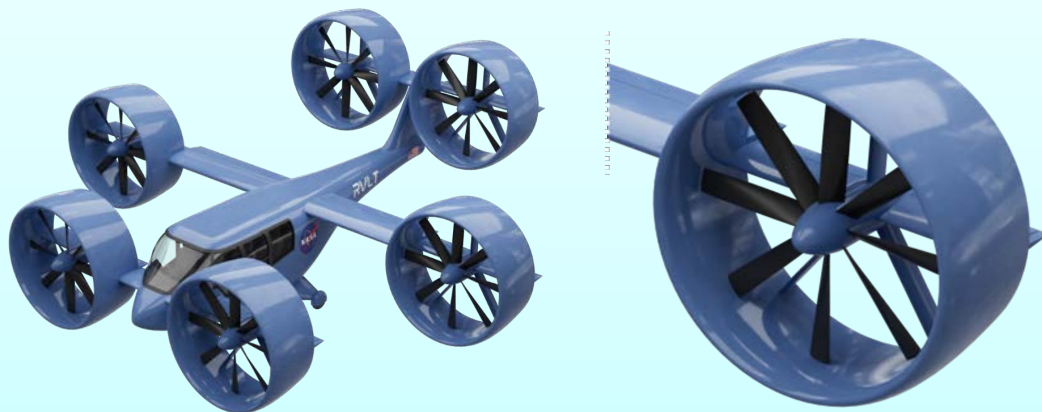

Background



Extended reacting liner

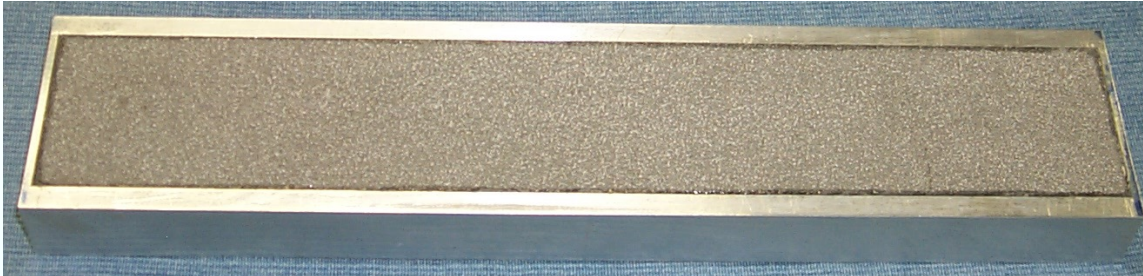

Local reacting liner

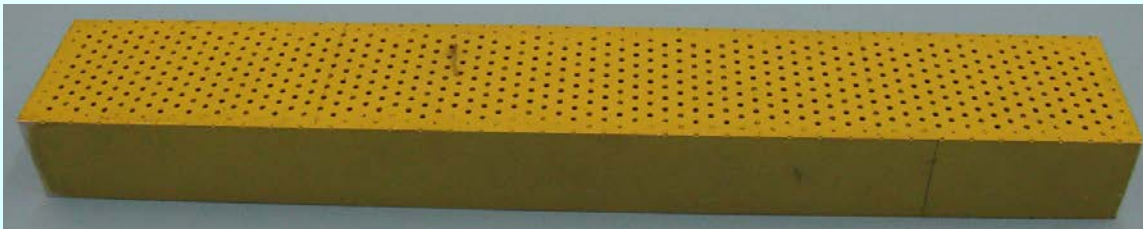

Demo

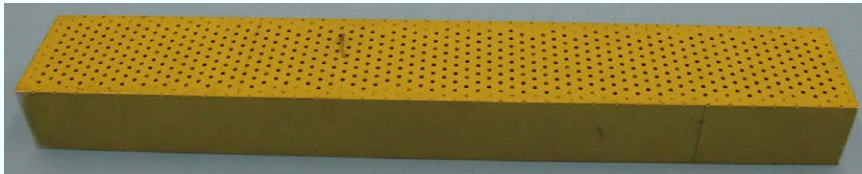
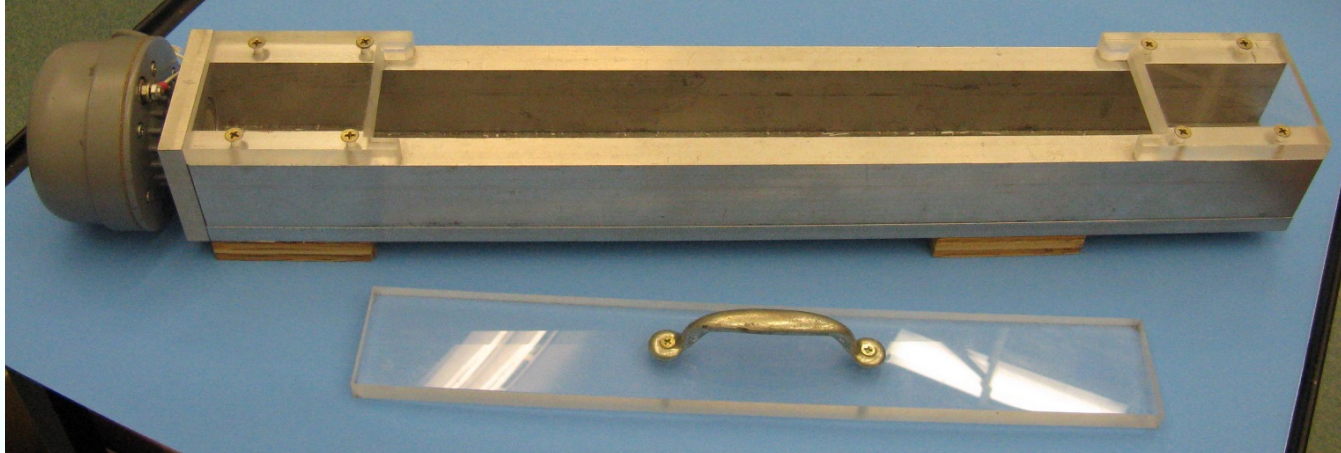

Local-Reaction Liner

Conventional, single-layer liner
Typically (incorrectly) labeled as SDOF

Extended-Reaction Liner
Unconventional, bulk liner
Wire mesh over ceramic beads



Demo



1.0 kHz, Hardwall

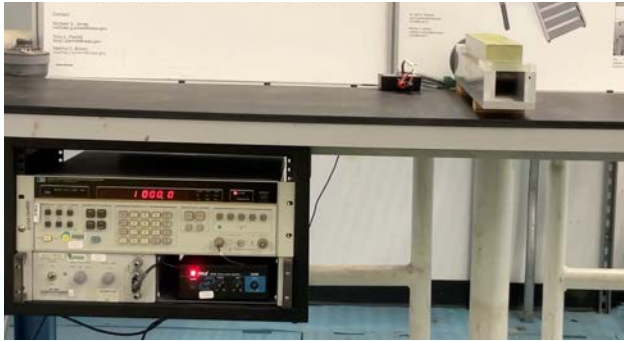

1.0 kHz, Local Reacting Liner

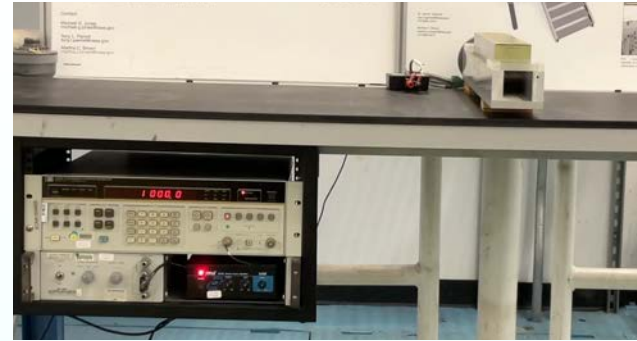

1.4 kHz, Hardwall

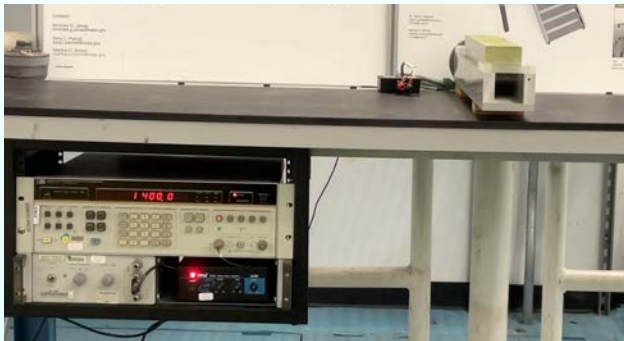

1.4 kHz, Local Reacting Liner

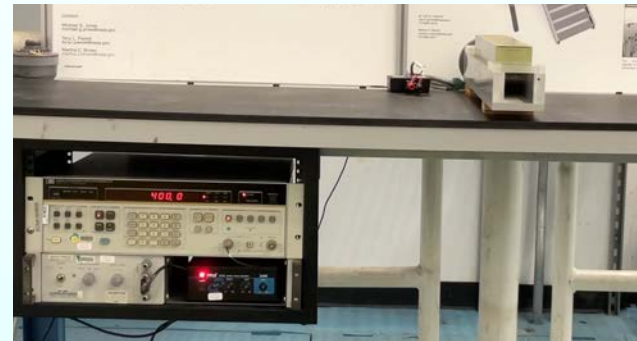

Broadband, Local Reacting Liner

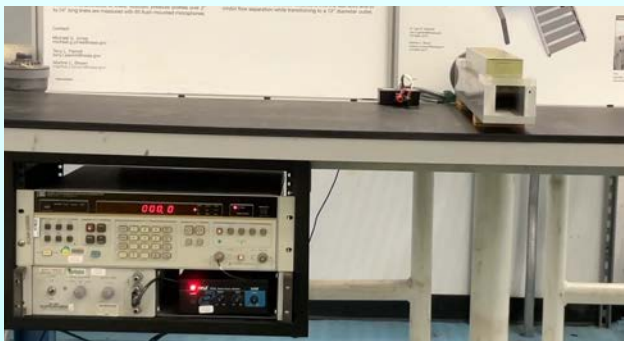

Broadband, Extended Reacting Liner

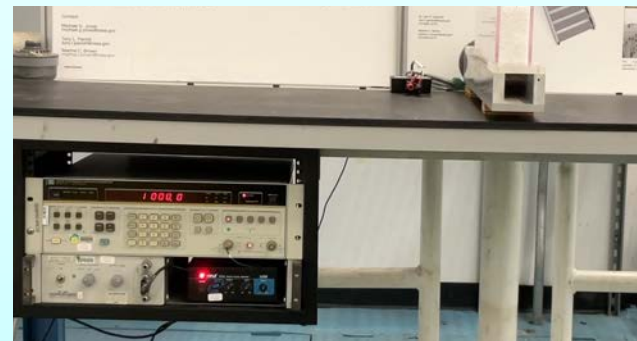

Extended-Reacting “Bulk” Liner

Zero-resistance facesheet + unblocked lateral wave

- Continuous distribution of resistance
- Attenuated internal wave propagation, reduced internal sound speed

Salient features

- Subdued depth-related resonance
- Improved absorption bandwidth
- Difficult to implement (weight, durability, fluid retention, etc.)
- Renewed interest (e.g., over-the-rotor, variable density)

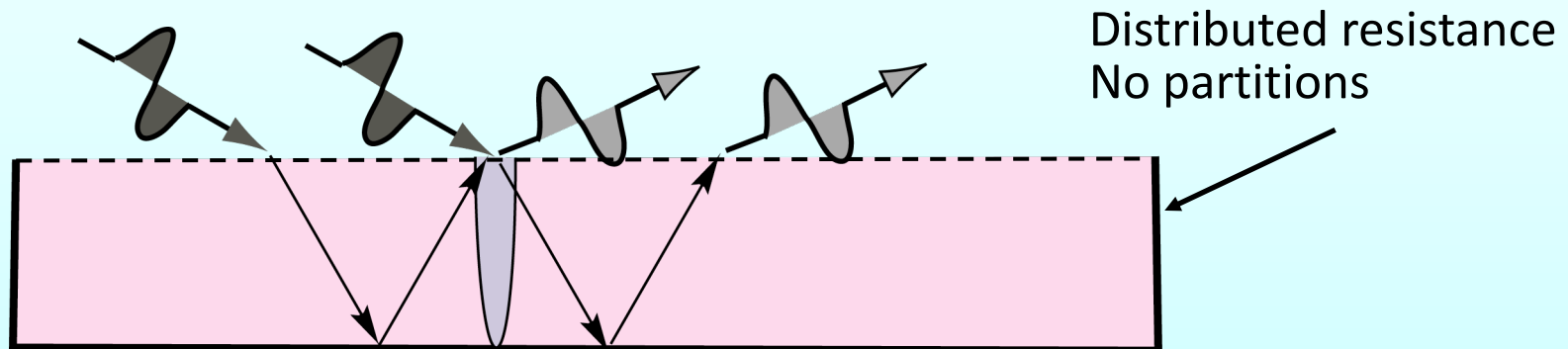
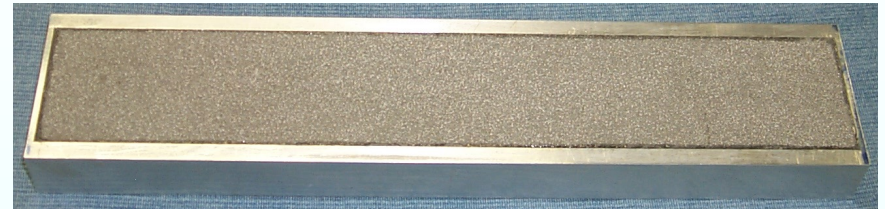

Local-Reacting Liner

“Thin” resistive facesheet + blocked lateral wave

- Spatially concentrated absorption
- Enhanced fluid pumping

Salient features

- Strong resonance
- Bandwidth limited absorption
- Very good for tones



This is focus of our research and this presentation

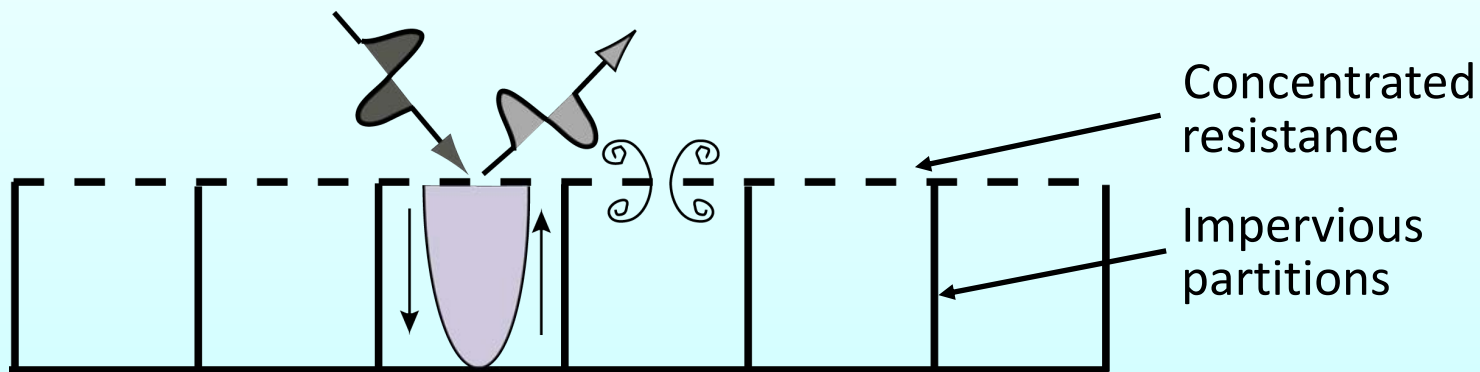

Conventional Liners

Single Degree of Freedom (SDOF)

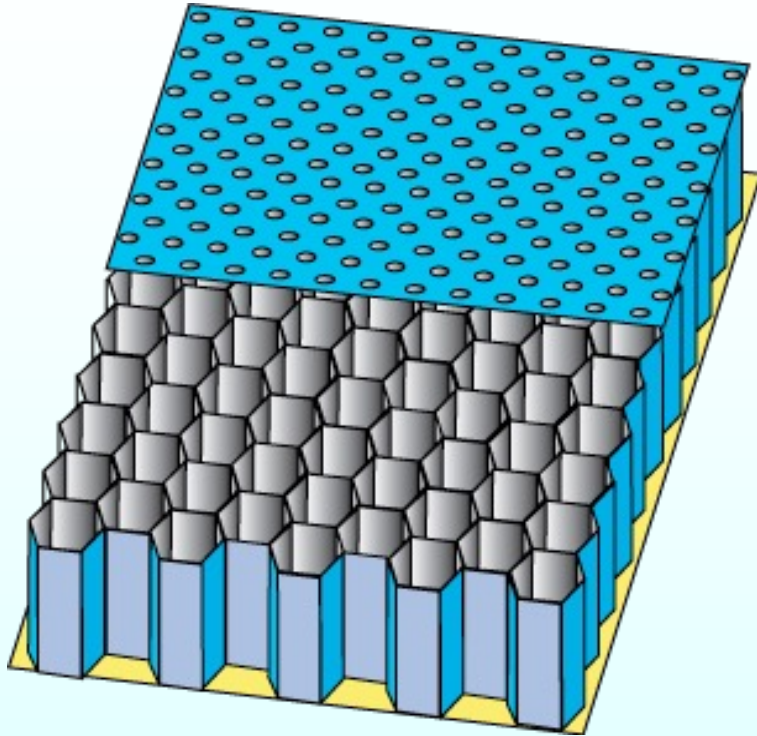

Two Degree of Freedom (2DOF)

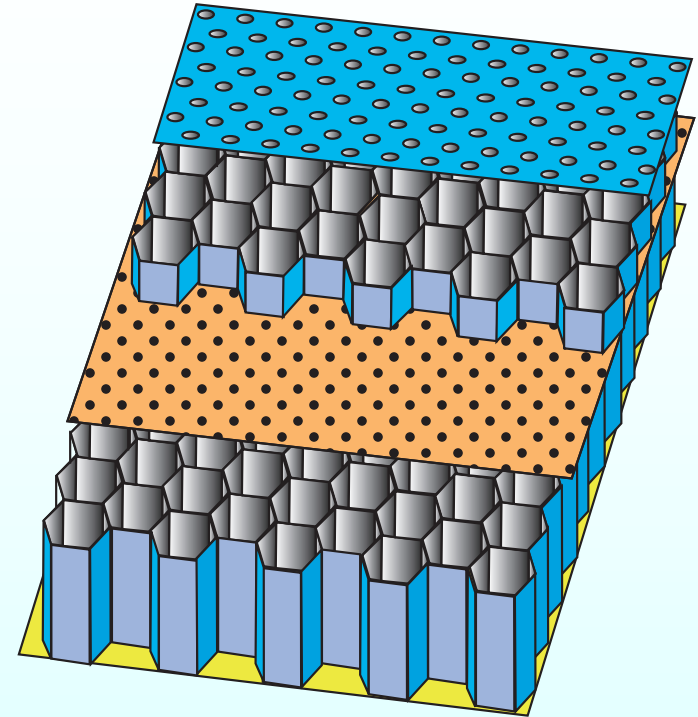

SDOF: acoustic performance dominated by depth mode (quarter-wavelength resonator), viscothermal losses

2DOF: sound absorption over a wider frequency range due to two interacting quarter-wavelength resonators

Key Parameter: **acoustic impedance, ζ** , at surface of liner

Acoustic Impedance

What is it?

- **Definition:**

$$\zeta = \theta + i\chi = \frac{\tilde{p}}{\tilde{v} \cdot \hat{n}}$$

Key parameter
Acoustic Impedance, ζ

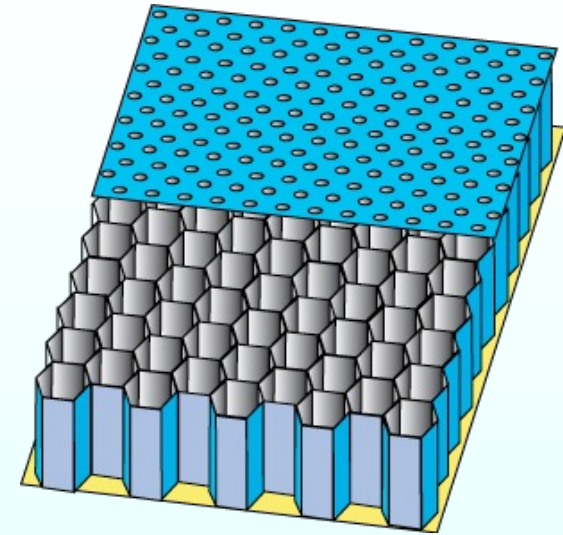

- **Resistance, θ :** A measure of the forces (e.g., viscous scrubbing losses) that dissipate energy
- **Reactance, χ :** “Gate” that determines the frequencies where energy conversion process is optimized

Acoustic Impedance

Why should I care?

- Intrinsic property of acoustic liner
- Independent of duct geometry
 - Detailed study in controlled environment (e.g., GFIT)
 - Suitable for predictions in aircraft engine nacelles

NASA Grazing Flow Impedance Tube

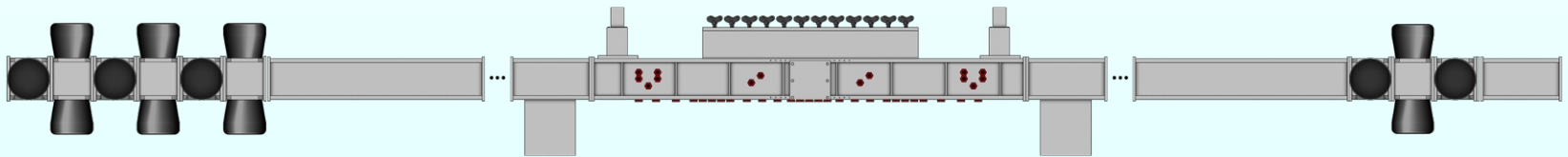

Propagation codes predict sound transmission through a duct. Acoustic liners are represented via impedance boundary condition.

Acoustic Impedance

What is a good impedance?

Function of:

- duct geometry
- aeroacoustic environment

Engine Design Trends

1960's – 1970's: BPR ~ 4

- Needed liners that absorbed tones (BPF, 2BPF, 3BPF)

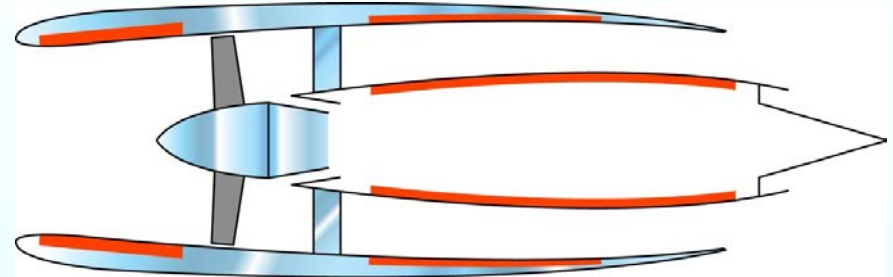

1990's – present: BPR > 9

- Need liners that absorb tones (low frequency) and broadband

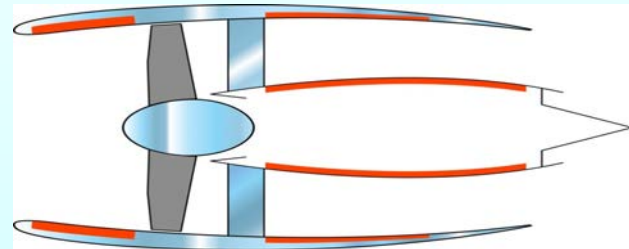

Configuration Effect on Absorption

Single-Layer Liner

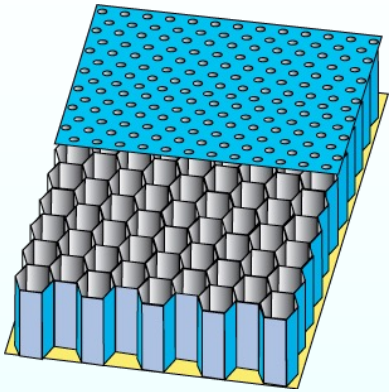

Two-Layer Liner

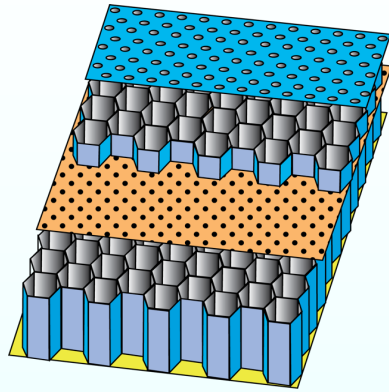

Metallic Foam Liner

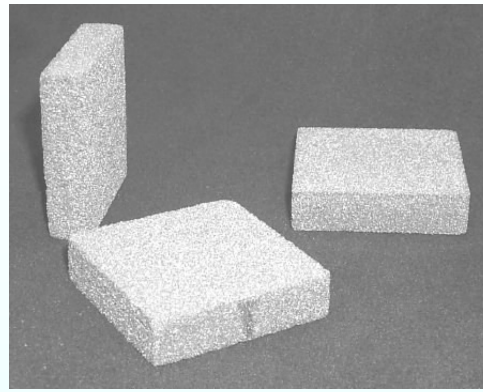

Variable-Depth Liner

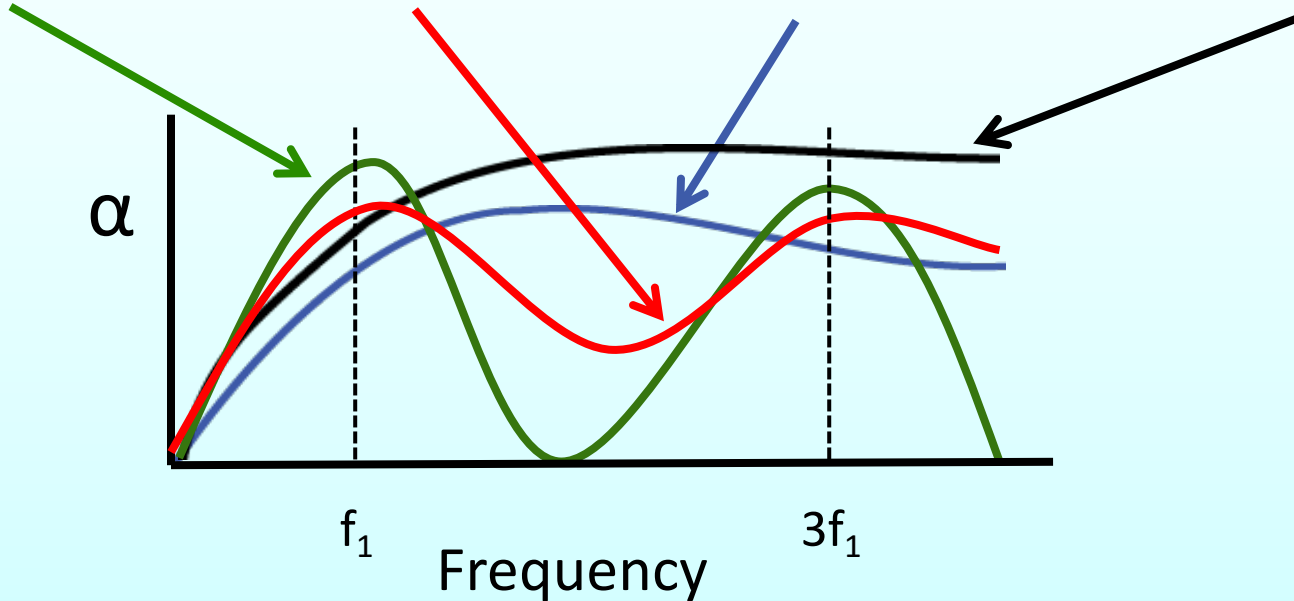
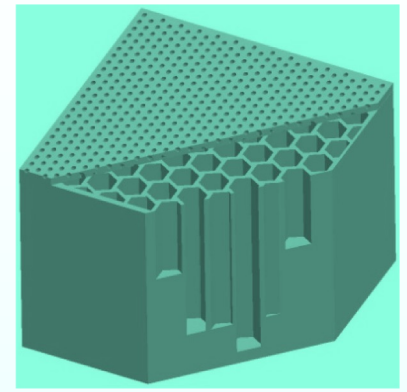

NASA Liner Technology Facility

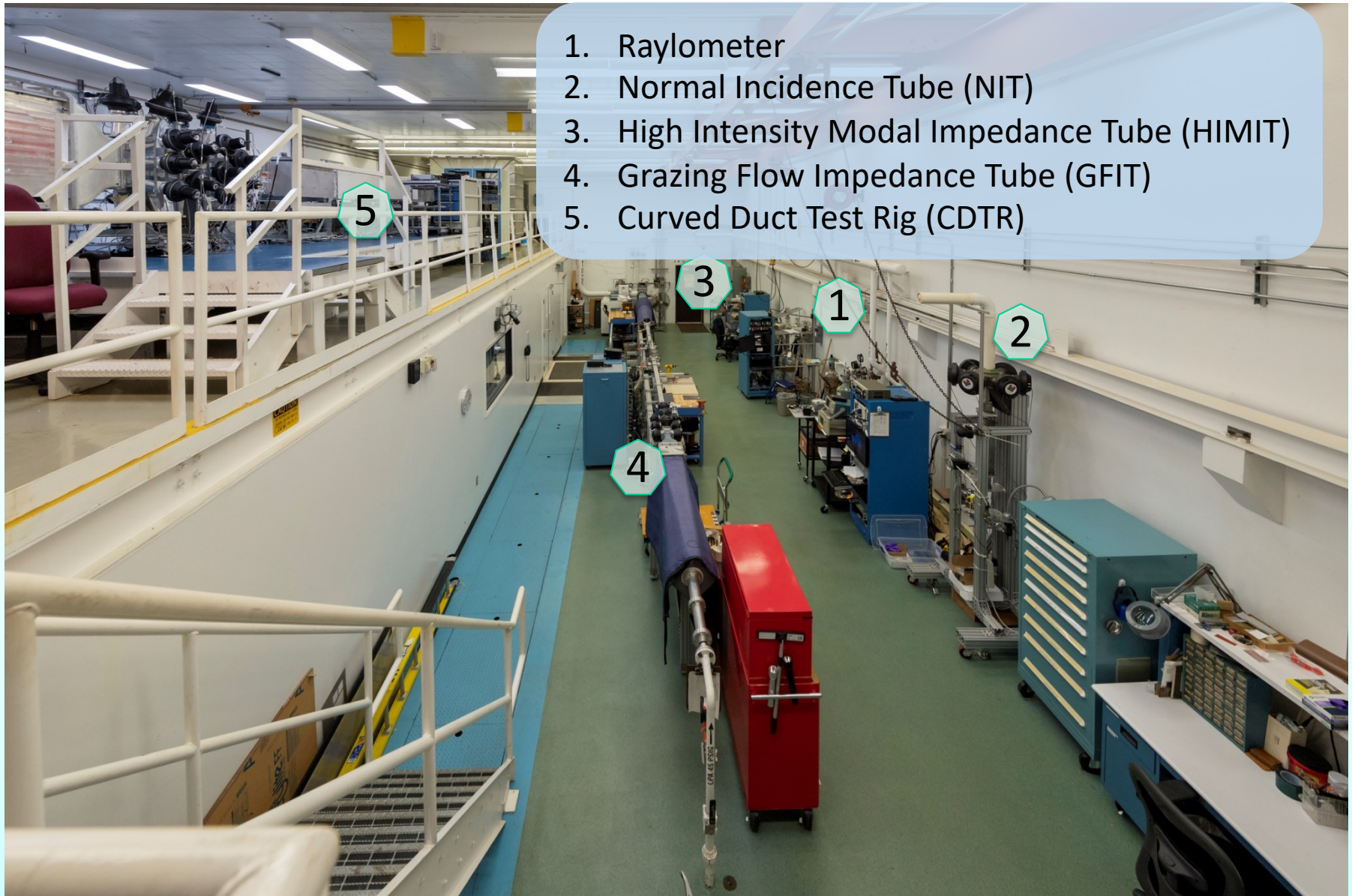

1. Raylometer
2. Normal Incidence Tube (NIT)
3. High Intensity Modal Impedance Tube (HIMIT)
4. Grazing Flow Impedance Tube (GFIT)
5. Curved Duct Test Rig (CDTR)

Acoustic Impedance Eduction



Raylometer

$R_f \rightarrow \theta(0 \text{ Hz})$



$$R_f = \frac{\Delta P_s}{u}$$

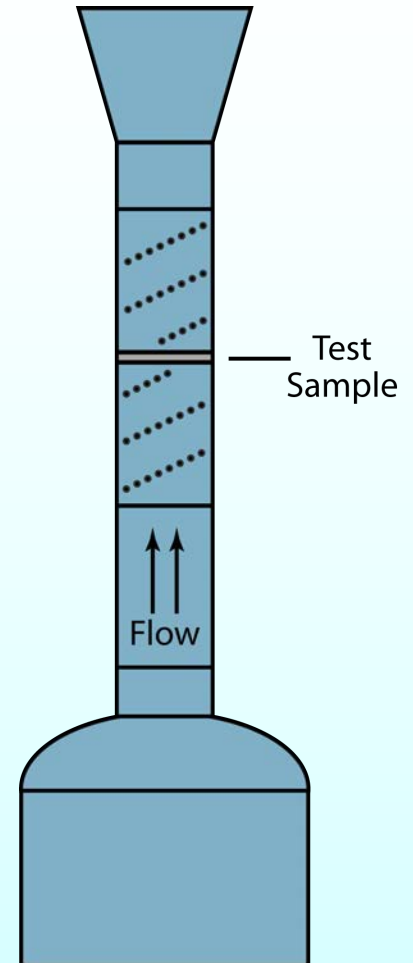
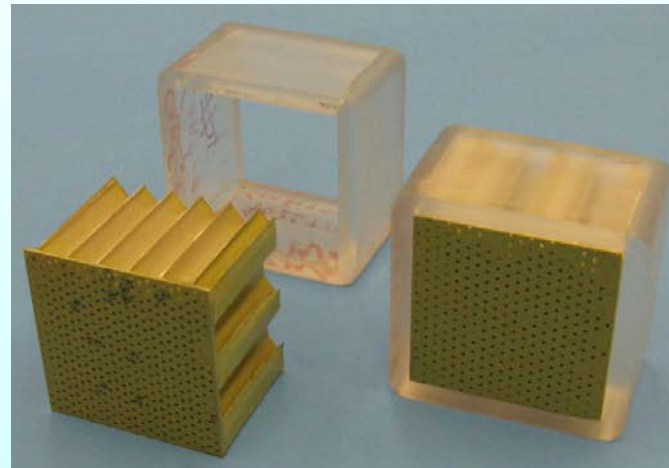

Acoustic Impedance Eduction

Normal Incidence Tube (NIT)

$\zeta(f, \text{SPL})$ at $M=0$, plane wave source : ≤ 3 kHz, 150 dB

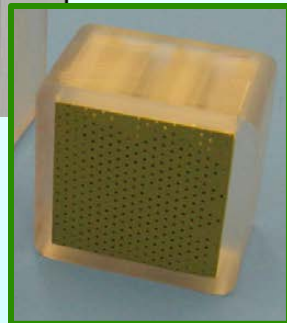

$$\left. \begin{array}{l} P_j = [P_i e^{i\Gamma x_j} + P_r e^{-i\Gamma x_j}] e^{-i\omega t} \\ P(x_1) \text{ and } P(x_2) \Rightarrow P_i \text{ and } P_r \end{array} \right\} R = \frac{P_r}{P_i} \Rightarrow \zeta = \frac{1 + R}{1 - R}$$

High Intensity Modal Impedance Tube

$\zeta(f, \text{SPL})$ at $M=0$, higher-order mode : ≤ 6 kHz, $\sim 160+$ dB



Acoustic Impedance Eduction



Grazing Flow Impedance Tube (GFIT)

$\zeta(f, SPL, M)$, plane wave source

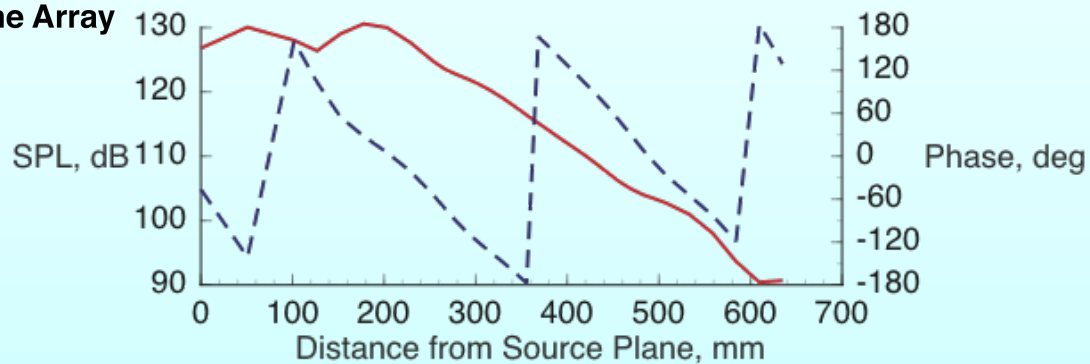
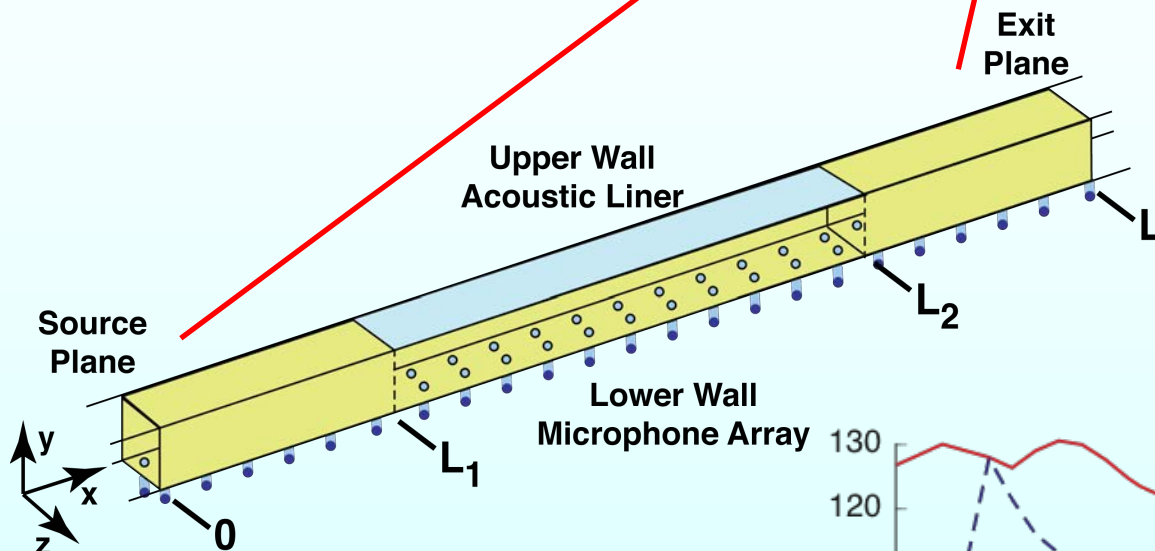
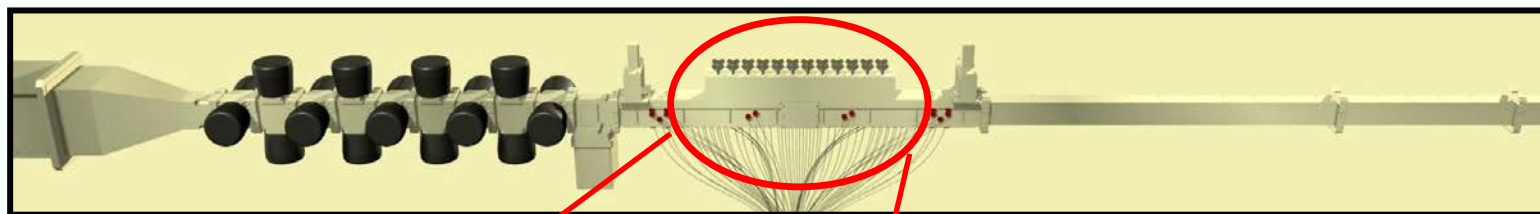



Acoustic Impedance Education

Grazing Flow Impedance Tube (GFIT)

$\zeta(f, \text{SPL}, M)$, plane wave source

Finite Element Method: Iterative Approach

- Assume an impedance, ζ
- Compute $p_{\text{pred}}(x)$; compare with measured $p_{\text{meas}}(x)$
- If they match within acceptable tolerance \rightarrow correct ζ
- If not, iterate on ζ and try again

Aeroacoustic Propagation Model

Convected Helmholtz:
$$(1 - M_0^2) \frac{\partial^2 p}{\partial x^2} + \frac{\partial^2 p}{\partial y^2} - 2ikM_0 \frac{\partial p}{\partial x} + k^2 p = 0$$

Boundary Conditions

Liner (Myers):
$$-\frac{\partial p}{\partial y} = ik \left(\frac{p}{\zeta} \right) + 2M_0 \frac{\partial}{\partial x} \left(\frac{p}{\zeta} \right) + \frac{M_0^2}{ik} \frac{\partial^2}{\partial x^2} \left(\frac{p}{\zeta} \right)$$

Rigid Wall:
$$\frac{\partial p}{\partial y} = 0$$

Source:
$$p_s(y)$$

Exit:
$$p_e(y)$$

Curved Duct Test Rig (CDTR)

Evaluate effects of higher-order modes

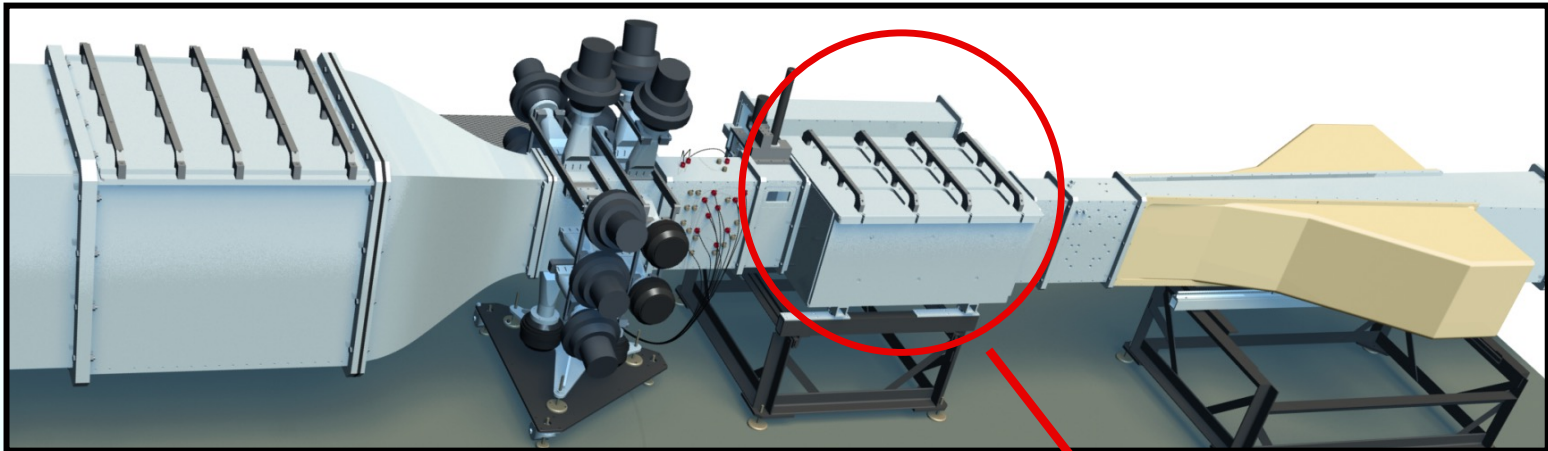

Use reduced impedance as BC in
aeroacoustic propagation code to
predict sound absorption in realistic
environment

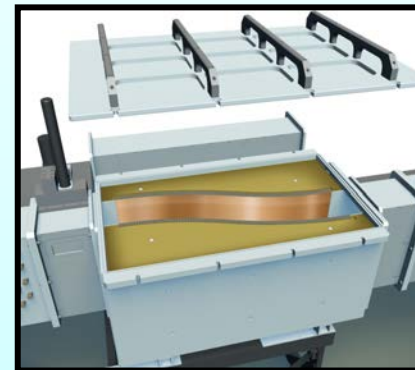

Validation Experiments



**Static Engine
Test Rig**

Photos provided by NASA GRC
and Honeywell Corporation

Novel Applications

**Over-the-Rotor
Liner**

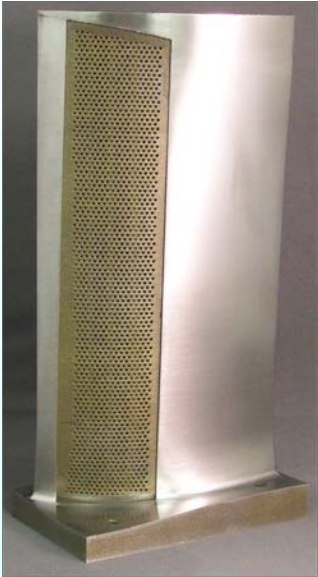
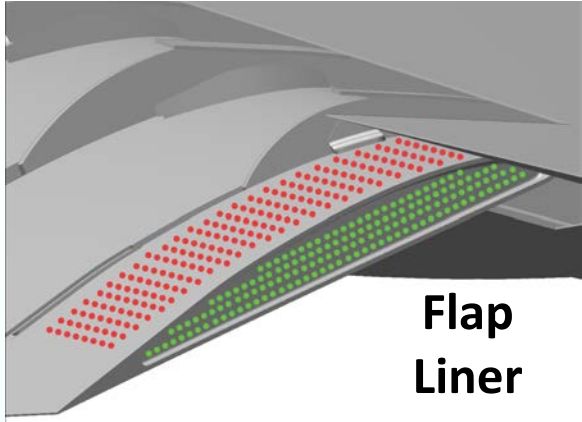
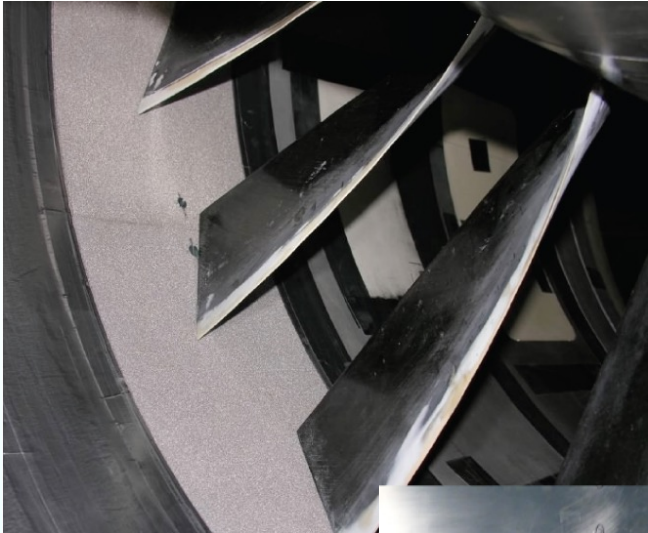

Soft Vane

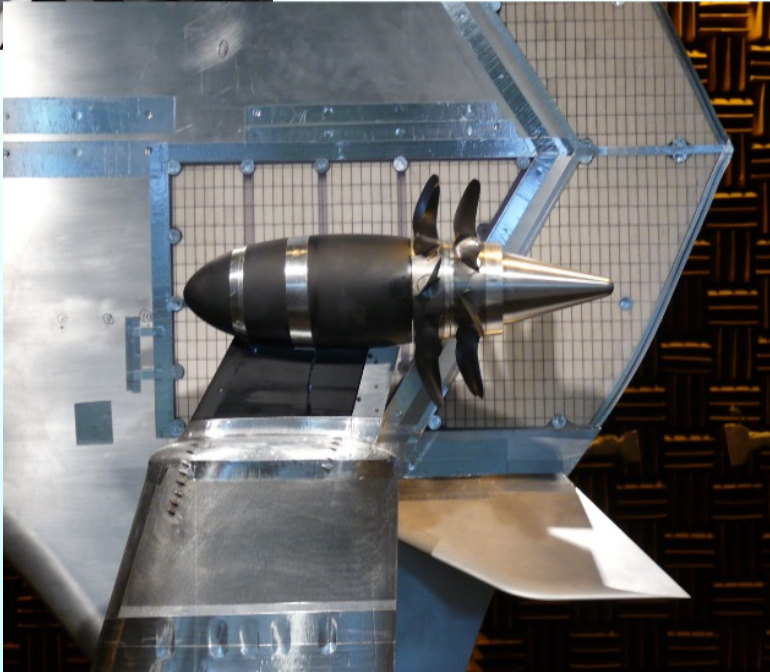

**External
Liners**

Photos provided by NASA GRC
and The Boeing Company

Novel Applications

- Increasing interest in multifunctional liners
- Example: thermoacoustic metaliner absorbs sound AND achieves desired temperature gradient (NASA SAA with OSU: Manimala, Biswas, and Kresl)

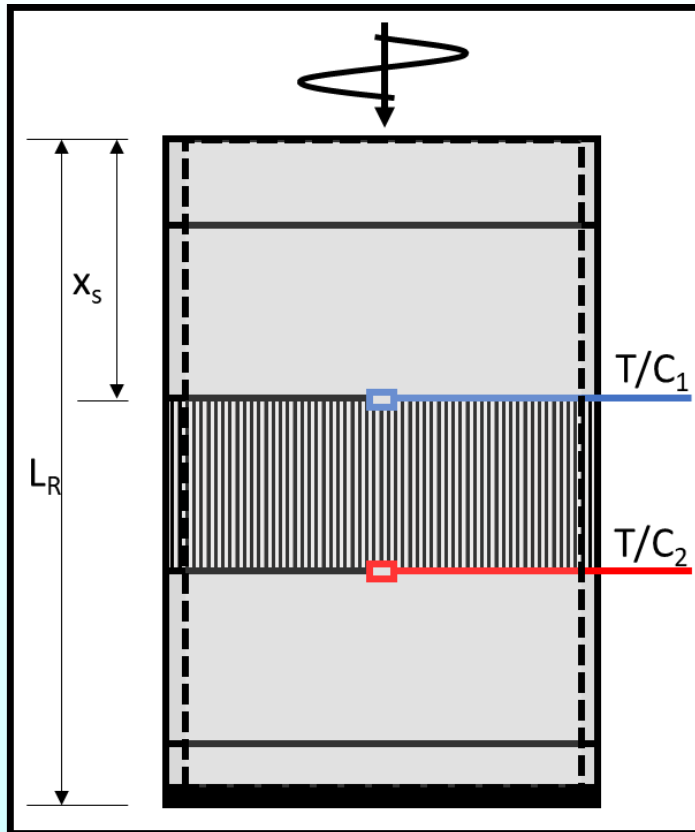

Sketch provided by
OSU (Manimala)

MDOF

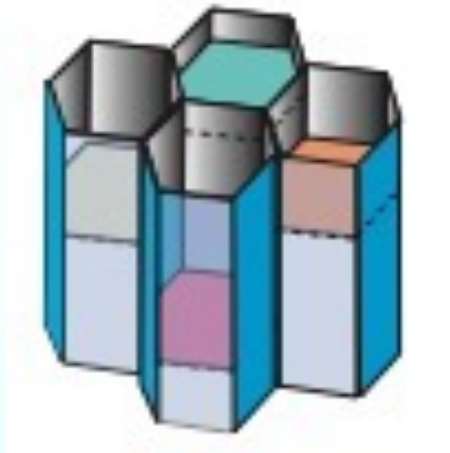

- Vary the impedance in adjacent chambers to achieve an improved effective impedance, resulting in improved broadband attenuation.
- Variability must be confined to spatial extent of approximately $\lambda/3$.
- Multi-degree-of-freedom configurations (MDOF) are flyable today.
- Advances in additive manufacturing have enabled numerous novel liner concepts. One concept of global interest is the variable-depth liner (VDL, Chambers PhD).
- Bent chambers enable low-frequency sound absorption.

VDL

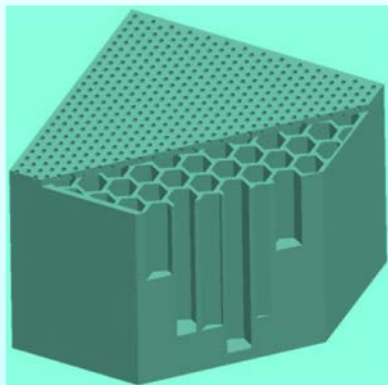

Bent Chamber

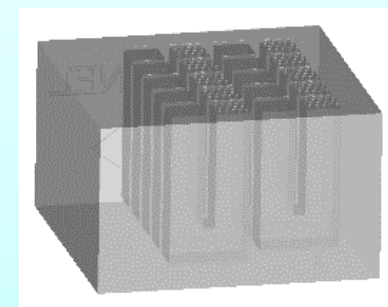

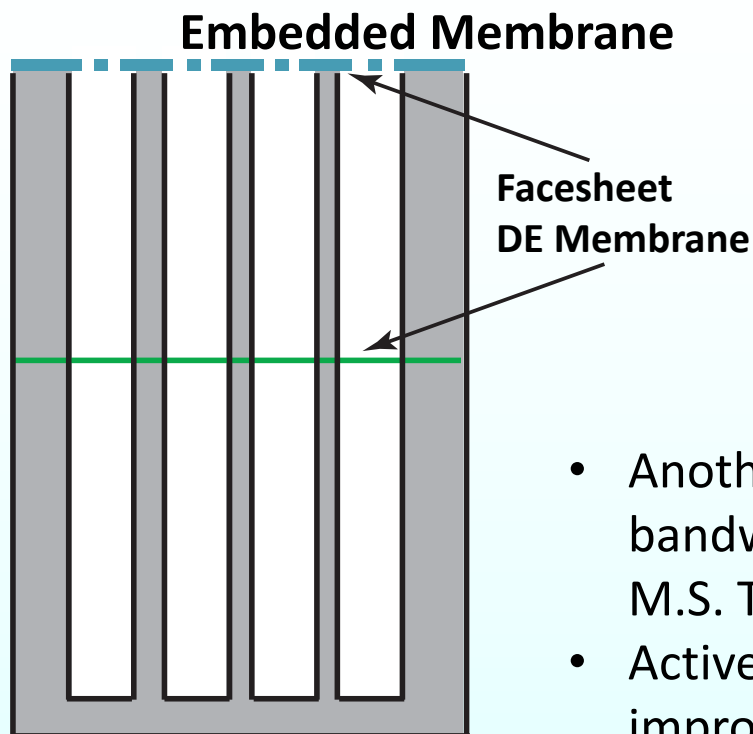

- Another way to increase sound absorption bandwidth is to insert a membrane (Svetgoff M.S. Thesis).
- Active components can be used to achieve improved performance. This configuration uses an embedded dielectric elastomer membrane (Solano PhD).

Novel Concepts

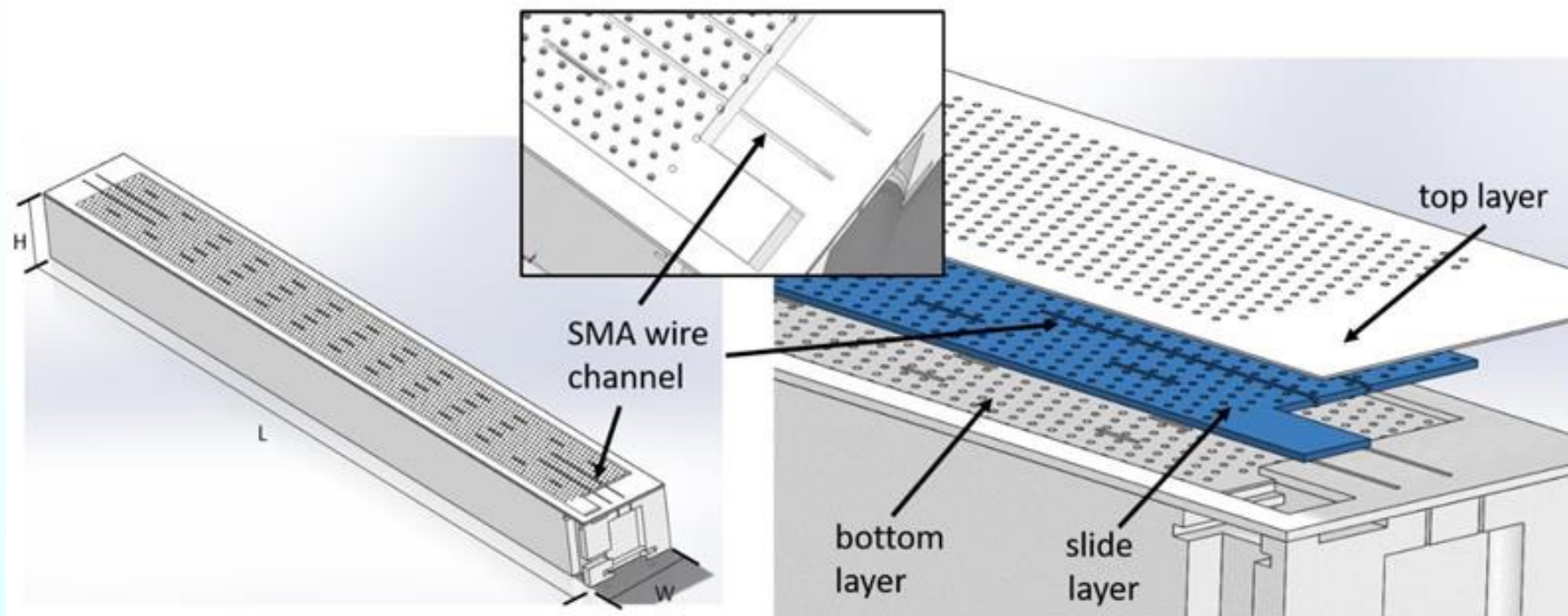

- A shaped memory alloy (SMA) is used to slide a movable perforated sheet between two static perforated sheets to achieve controllable porosity, thereby enabling active partial impedance control (Boeing/FSU NRA).
- Concept was previously investigated (without SMA) at GTRI (Ahuja/Gaeta).

From Modeling to Flight Test

- Develop, evaluate, and improve impedance prediction models
 - Excellent review of pre-2000 history compiled by Dr. Gaeta
- Connect them with propagation codes, both in-house (CDL) and commercial (ACTRAN, COMSOL), to predict sound field in increasingly complex aeroacoustic environments
- Flight test (2018) with B737MAX – used full toolset to design inlet with 3DOF core and slotted facesheet; achieved significant noise and drag reductions relative to current production inlet



Photo provided by
The Boeing Company

NASA Opportunities



- NASA Student Programs
<http://www.nasa.gov/centers/langley/education/forstudents.html>
- Langley Internship (~10 week program, typically during summer)
- Collaborations (Space Act Agreements)
 - Dr. Manimala: thermoacoustic liners
- EPSCoR Agreements

Questions?

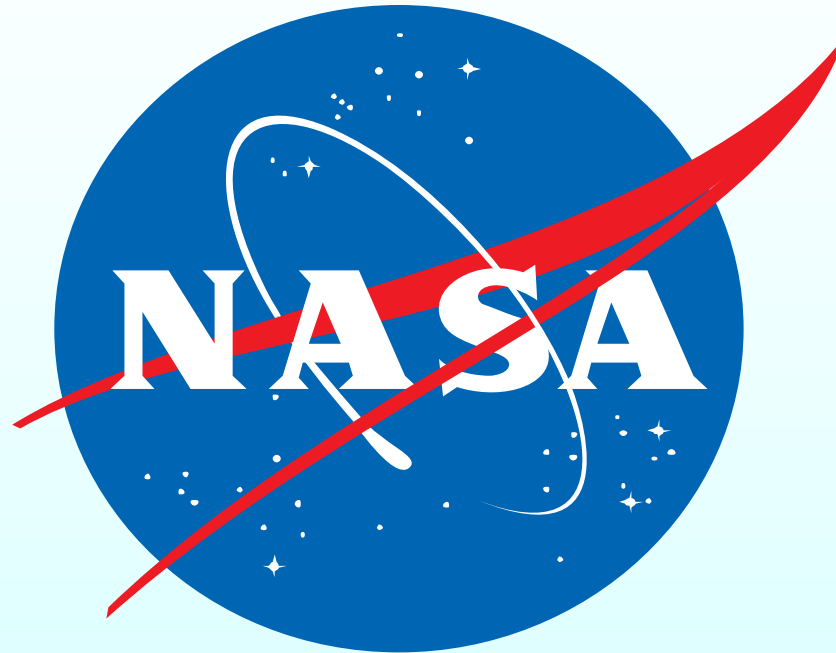

Backup Slides



Technology Readiness Level (TRL)



1. Basic principles observed and reported
2. Technology concept and/or application formulated
3. Proof-of concept demonstrated
4. Component validation in laboratory environment
5. Component validation in relevant environment
6. System/subsystem model or prototype demonstration in relevant environment (e.g., static engine test)

**NASA
Focus**

7. System prototype demonstration (e.g., flight test)
8. Actual system completed and “flight qualified” through test and demonstration
9. Actual system “flight proven” through successful mission operations