

# PRIME-1

## Polar Resources Ice Mining Experiment-1

NASA's First Polar Drilling and Volatiles Detection  
Mission on the Moon

J.W. Quinn<sup>1</sup>, J.E. Captain<sup>1</sup>, A.S. Eichenbaum<sup>1</sup>, R. Augilar-Ayala<sup>1</sup>, J.E. Kleinhenz<sup>1</sup>, K.A. Zacny<sup>2</sup>, P.C. Chu<sup>2</sup> and V.R. Vendiola<sup>2</sup>, <sup>1</sup>NASA (Mailstop UB-E, KSC, FL 32899 Jacqueline.W.Quinn@nasa.gov), <sup>2</sup>Honeybee Robotics (2408 Lincoln Ave Altadena, CA 91001 kazacny@honeybeerobotics.com).

- NASA is leveraging novel public/private partnerships with industry to meet the Agency's objective to return to the surface of the Moon and develop a sustainable lunar ecosystem
- NASA's initial approach to fulfill this goal was to fly payloads that could be ready to land on the Moon early this decade, some of which would help inform ISRU objectives
- PRIME-1 is a Space Technology Mission Directorate ISRU payload
- The instruments that make up PRIME-1 are:
  - MSolo (Mass Spectrometer observing lunar operations)
  - TRIDENT (The Regolith Ice Drill Exploring New Terrain)
- PRIME-1 will attempt to acquire a direct measurement of polar volatiles, informing our understanding of the lateral and vertical distribution of the volatiles at the landing location down to a meter deep from Intuitive Machine's Nova-C lander

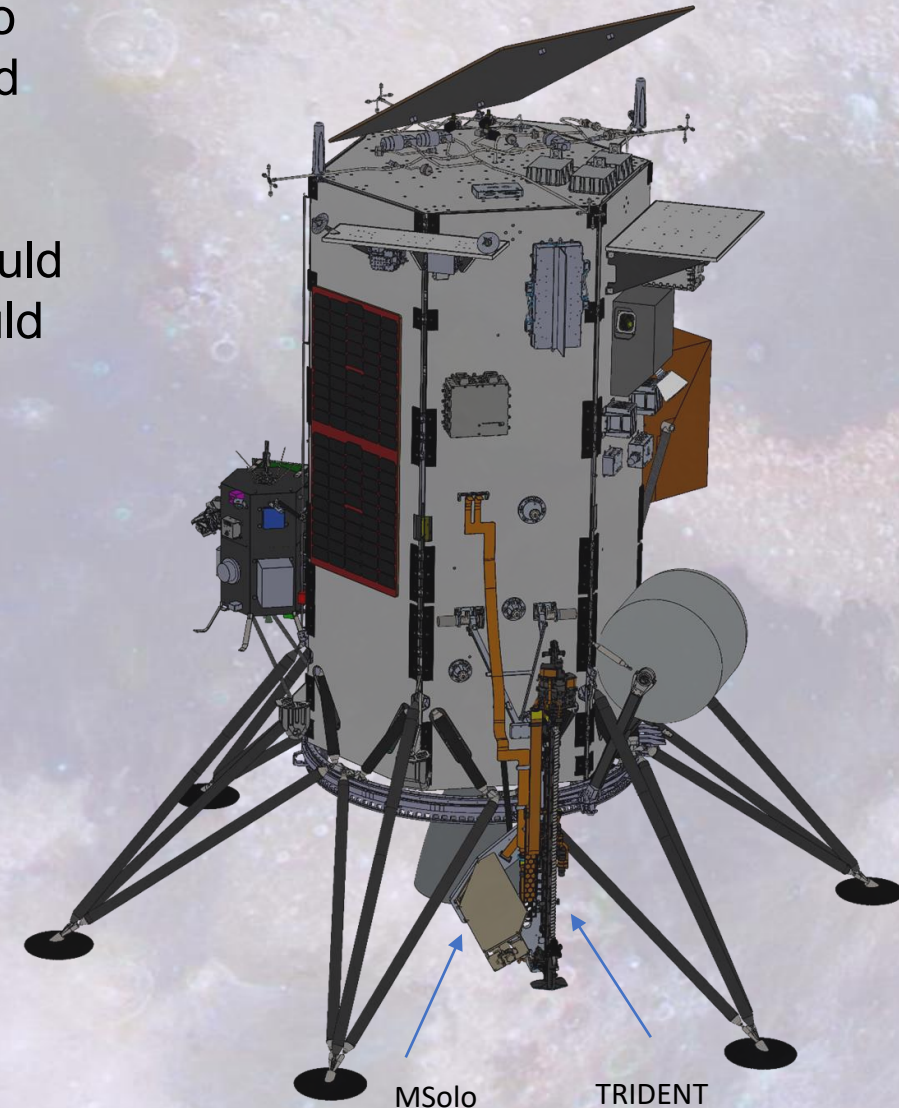

➤ Contributing partners and/or stakeholders

- Honeybee Robotics – TRIDENT drill commercial partner (CA and CO offices)
- INFICON – MSolo mass spectrometer commercial partner (NY)
- Blue Sun – SBIR Phase III Virtual Machine Language (CO)
- National Science Foundation (NSF) – SHREC (Space, High-performance, and Resilient Computing) Space Processor design
- SMD – Commercial Lunar Payload Services (CLPS) carrier contract and Science modeling (two SSERVI nodes participating)



MSolo on vibration test fixture

➤ Mission Infusion

- PRIME-1 is currently targeting a late CY 2023 CLPS mission to Shackleton's connecting ridge at the lunar south pole; carried by Intuitive Machines
- PRIME-1 will help to inform the Agency plan for ISRU prospecting at the lunar poles
- PRIME-1 will inform VIPER mission ops
- Any data acquired from the operation of PRIME-1 will be uploaded to the Planetary Data System for use by the lunar science community and the ISRU community



TRIDENT mounted on Intuitive Machines  
3PO Pallet

PRIME-1

MSolo



## PRIME-1 Mission Objectives

<b>Objective #1</b>	TRIDENT will drill into the lunar subsurface up to a meter deep and deliver regolith cuttings to the surface for water and other volatiles evaluation by MSolo
<b>Objective #2</b>	MSolo will measure within its field of view, the composition of gases emanating near the TRIDENT drill before, during and after drilling activities

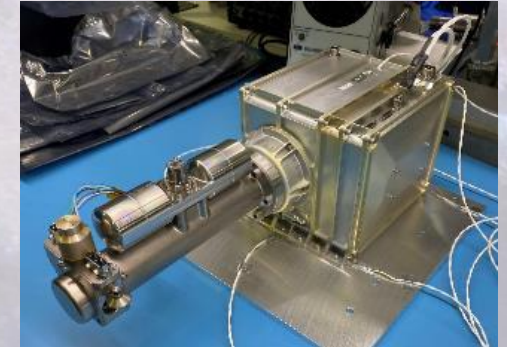

MSolo flight unit

## PRIME-1 Level 1 Requirements

<b>Requirement #1</b>	PRIME-1 shall operate on the surface at a lunar polar region
<b>Requirement #2</b>	PRIME-1 shall expose a subsurface regolith sample from up to a 1-meter depth drill hole
<b>Requirement #3</b>	PRIME-1 shall analyze the exposed subsurface regolith sample to detect water and other volatiles

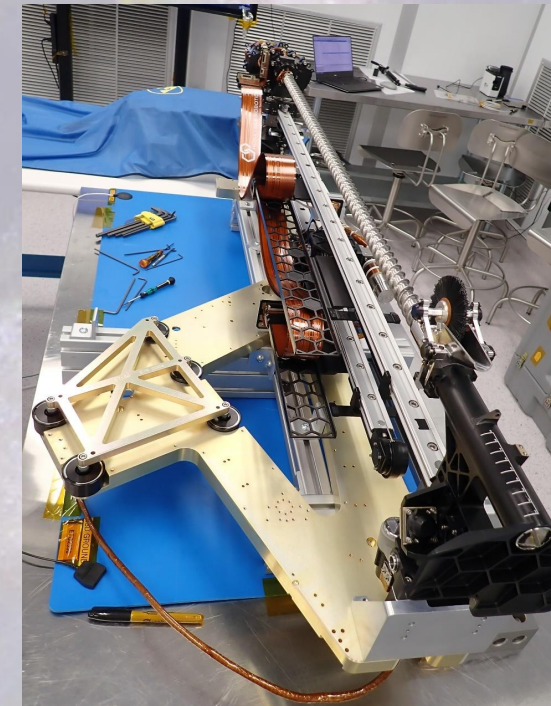

PRIME-1 mechanical fit check on Intuitive Machines' Primary Payload Precision Off-loader (3PO) platform

..... Project Start    
 ▣ Project Milestone    
 ◆ GCD (Key) Milestone    
 ▼ Controlled Milestone

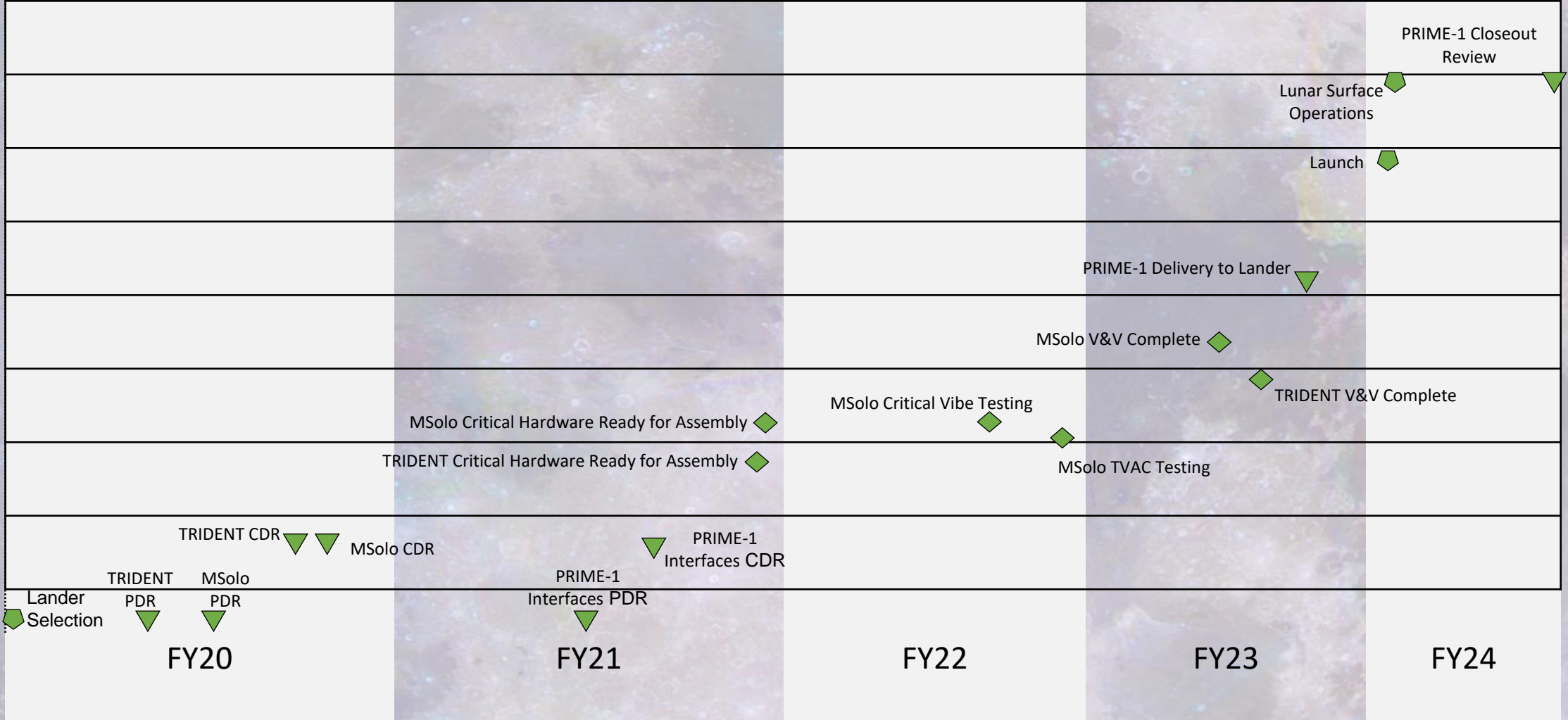

- TRIDENT (The Regolith and Ice Drill for Exploring New Terrains) subsystem includes the hardware to physically **excavate/extract regolith from the lunar surface up to a depth of 1 meter**.
- Excavation device will be instrumented to **measure forces/displacements** in order to determine critical bulk properties of the regolith. This information will be used to understand the working environment and **bound critical excavation parameters for future larger scale regolith mining** equipment and processes.
- TRIDENT captures regolith in **8-10 cm increments** down to a depth of 1 meter. Material captured by the drill is transported to the surface to be analyzed by **MSolo**. TRIDENT measures **strength of the lunar regolith as well as subsurface temperatures** during drilling operations.

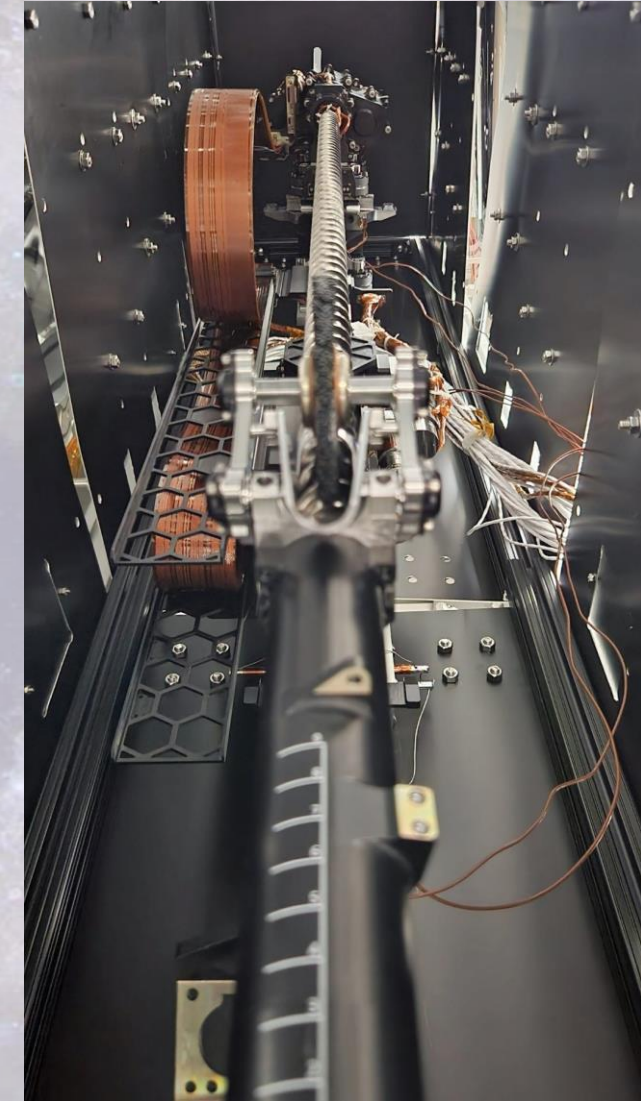

- TRIDENT Instrument consists of three major sub-systems:
  - Drill Mechanism & Launch Locks
  - Avionics
  - Cable Harness

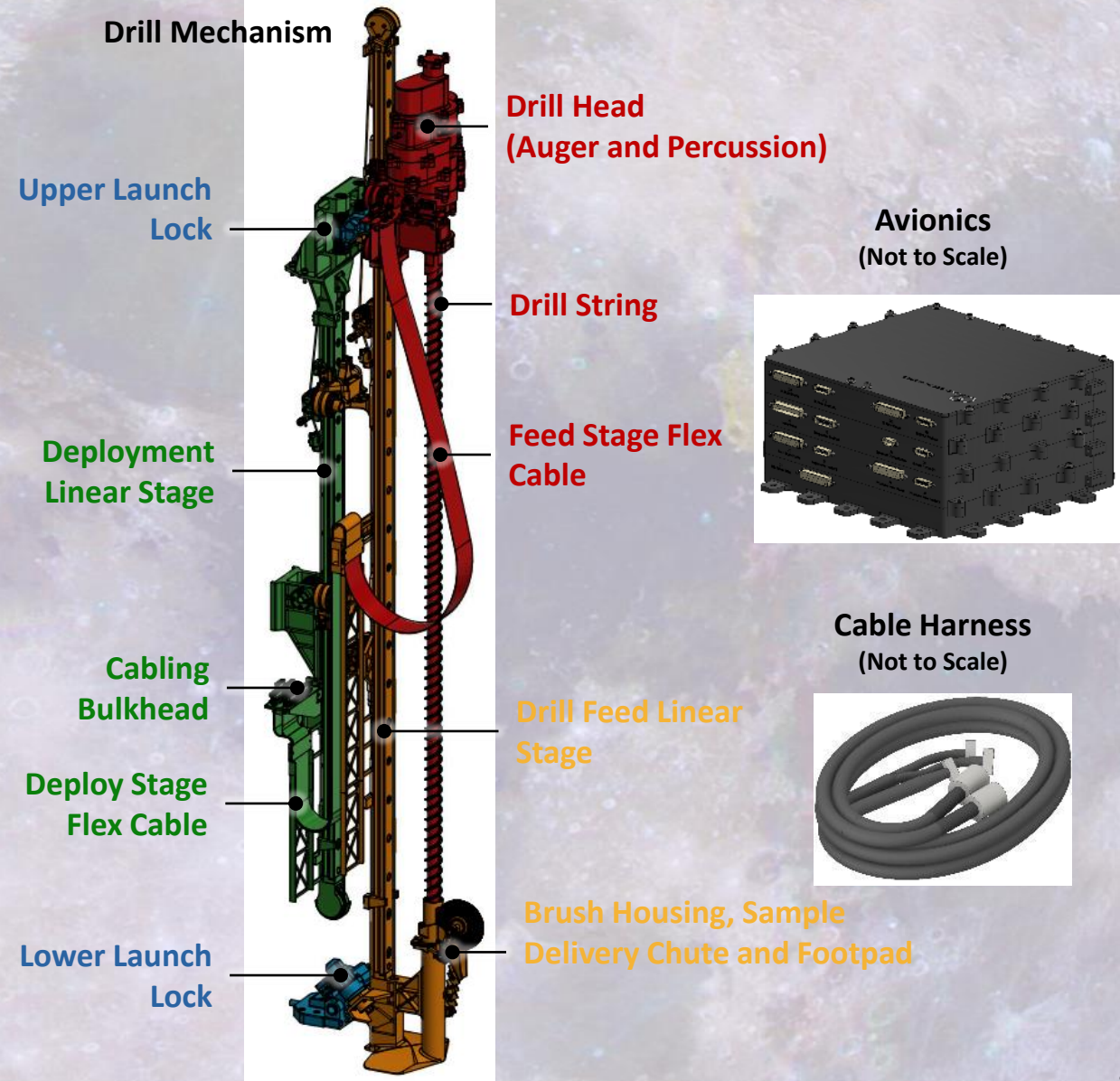
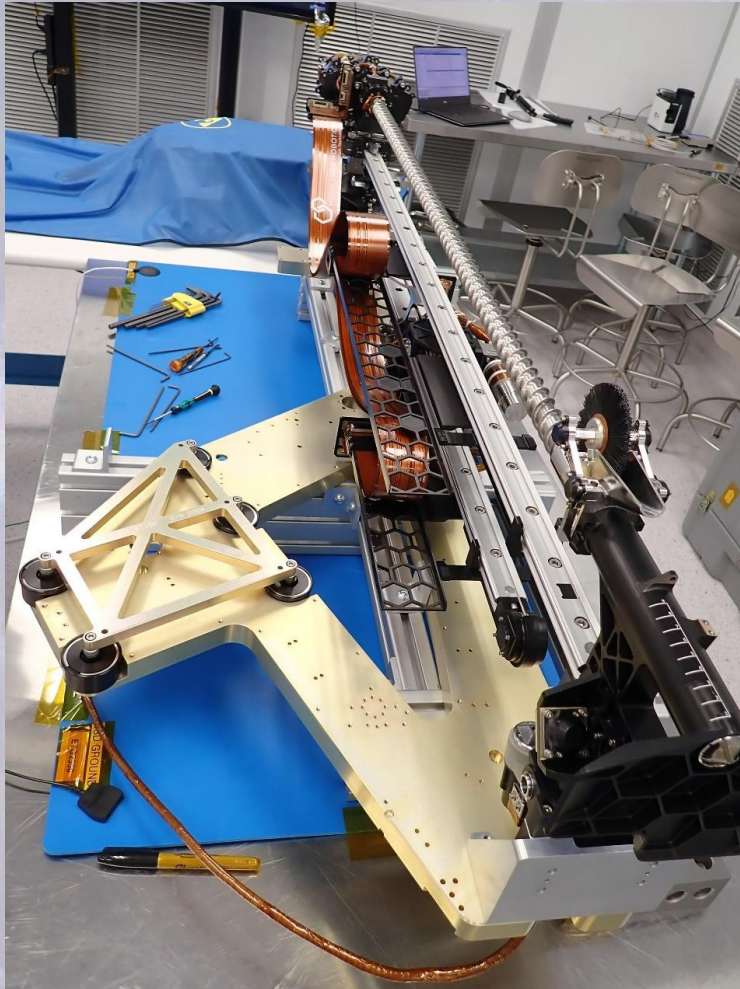

## TRIDENT Science Data

### Bit Temperature Sensor (#):

- Subsurface Temp vs Depth

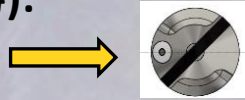

### Cuttings cone (\*):

- Angle of Repose
- Density at Dr of ~0%

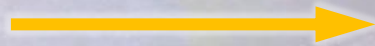

### Footpad sinkage provides (#):

- Bearing capacity



### Drilling Power (#):

- Material Strength vs. Depth
- Loose ice grains vs ice cemented regolith



### Heater (#):

- Thermal Conductivity (with Temp. Sensor)

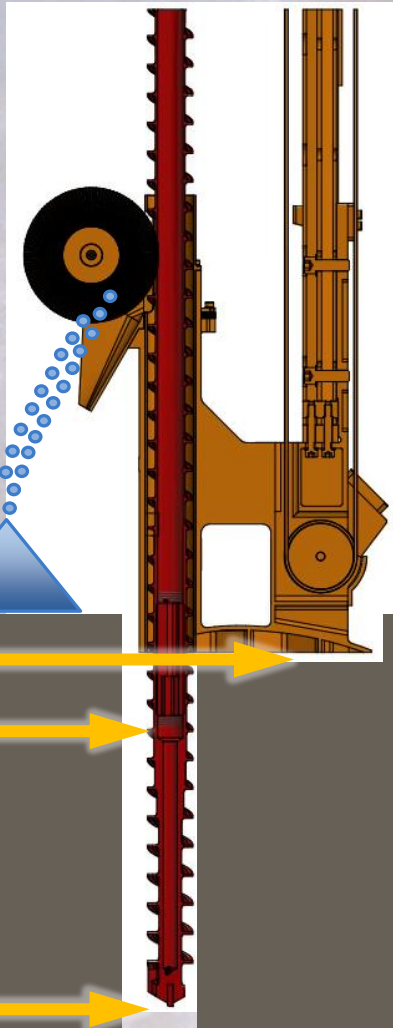

## Engineering Specifications

Parameter	Value
Bit Diam. (mm)	25.4
Nominal Auger Spin (RPM)	120
Auger Average Output Torque (N-m)	5.5
Auger Average Power Consumption (W)	87
Percussion Impact Energy (Joules/Blow)	2
Nominal Percussion Rate (BPM)*	972
Feed Stage Stroke (mm)	1240
<b>Maximum Drill Depth (mm)</b>	<b>1020</b>
Deployment Stage Stroke (mm)	380
Z Stage Force Cont. (N)	500
<b>CBE Drill and Launch Locks Mass (kg)</b>	<b>~22</b>
<b>CBE Avionics + Harness Mass (kg)</b>	<b>~7</b>

- The cuttings pile size increases with each bite, evenly falling into a cone shape on the surface.

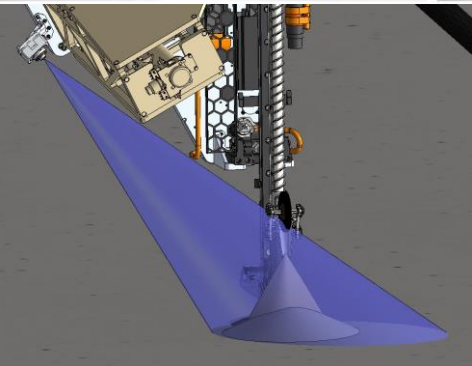
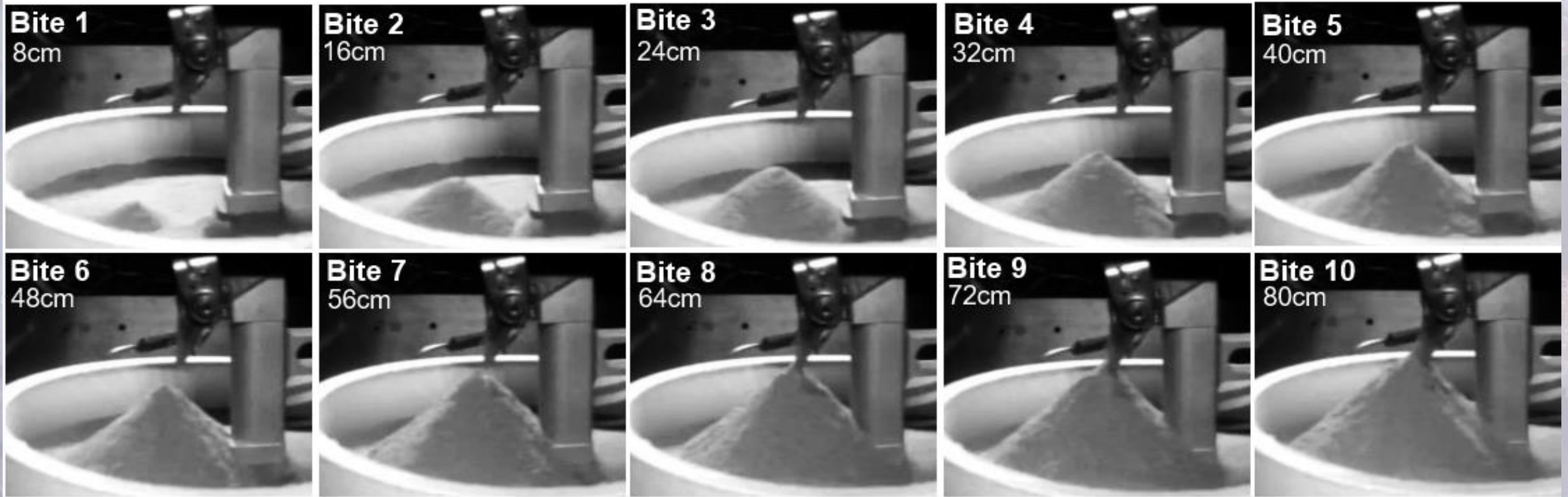

The lander partner will provide regular camera imagery of the cuttings pile while in flight.  
- Images provided every minute during active operations, every 5min during analysis hold periods

- Lower Power
- Stratigraphy is preserved in 8-10 cm “Bites”
- Accurate material strength determination
- More accurate downhole temperature
- Reduced risk of freezing-in

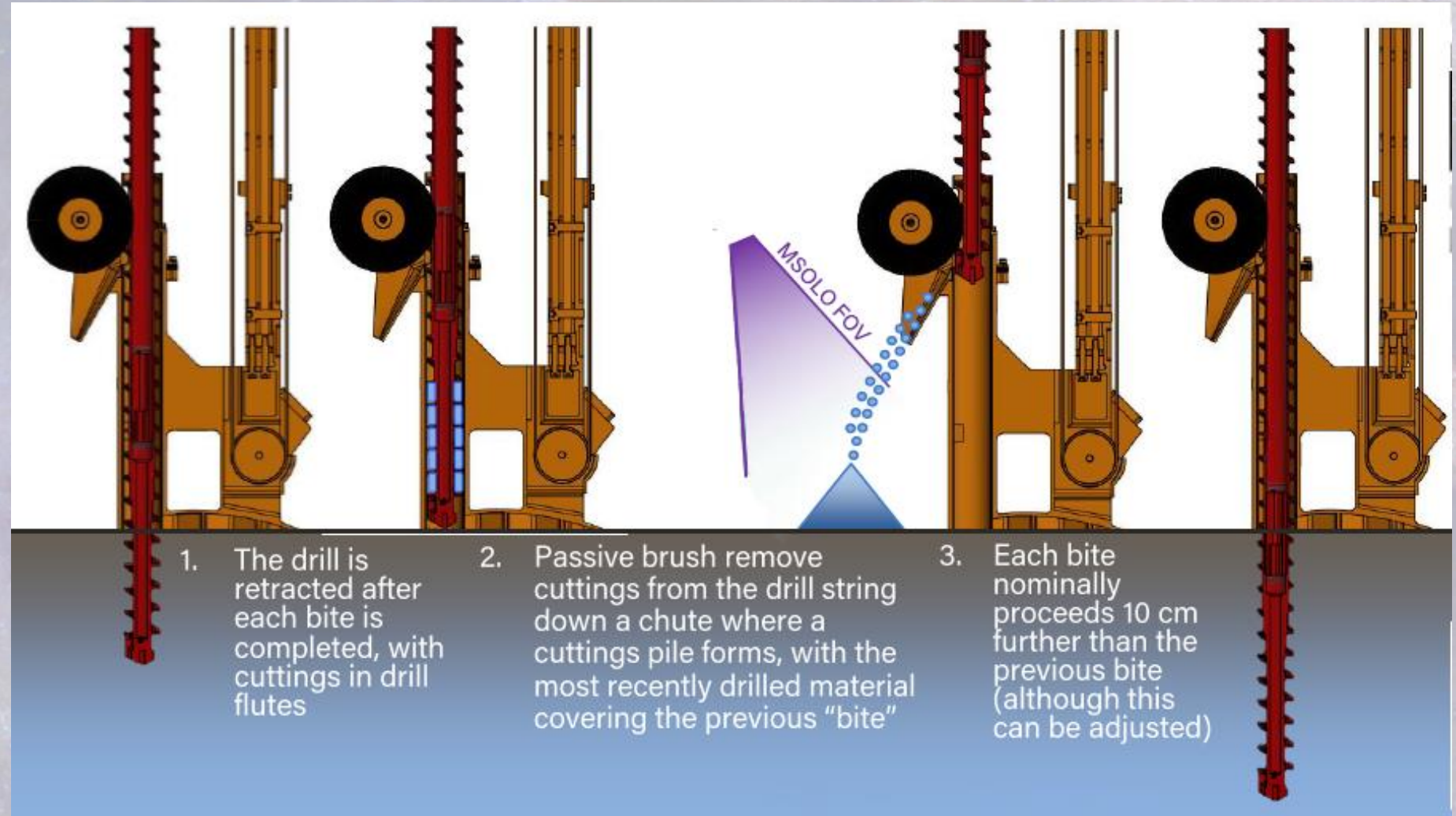

# MSolo-a modified for spaceflight commercial-off-the-shelf (COTS) Mass Spectrometer

- INFICON Quadrupole mass spectrometer
- Open or Cross Beam Ion Source (COTS)
- Electron impact ionization - Dual  $Y_2O_3$ /Ir filaments (COTS)
- Faraday Cup and Electron Multiplier Detectors (COTS)
- Calibration Gas System (KSC)
- Chassis designed to build on instrument avionics and include spaceflight control computer (SHREC) and power board

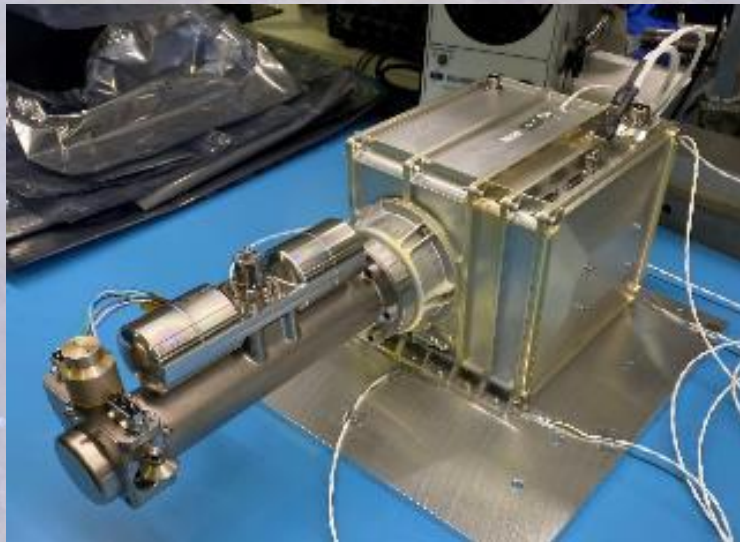

Cross  
Beam  
Ion  
Source



Open  
Ion  
Source



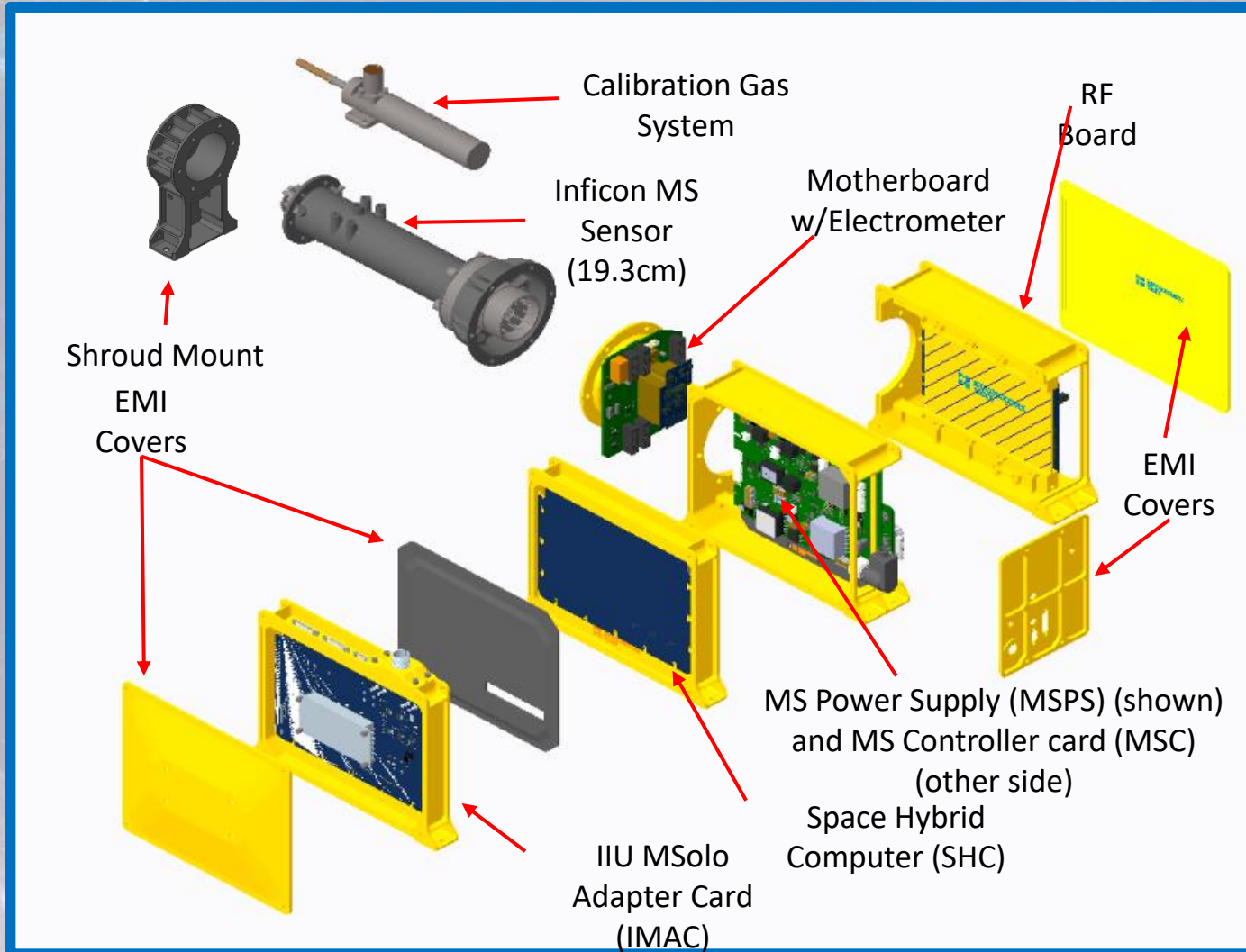

## Ruggedization for Spaceflight

- Calibration Gas System
- Thermal upgrades
- Structural Upgrades
- Onboard computer designed
- Avionics board redesign
- New chassis to support COTS MS Boards, new power boards and onboard computer
- Software designed to be compatible with RS422 and COTS firmware/operation



- Designed for analysis of molecular or pseudo-molecular beams traveling axially to the sensor
- Less sensitive to overall background gas composition, enhanced directional sensitivity
- Allows accurate sampling of a dynamic system, especially a flux from a particular source
- Apertures in shroud along with the ion source configuration provide increased tolerance to particulate contamination





Inlet hole is aligned with anode cage in crossbeam configuration

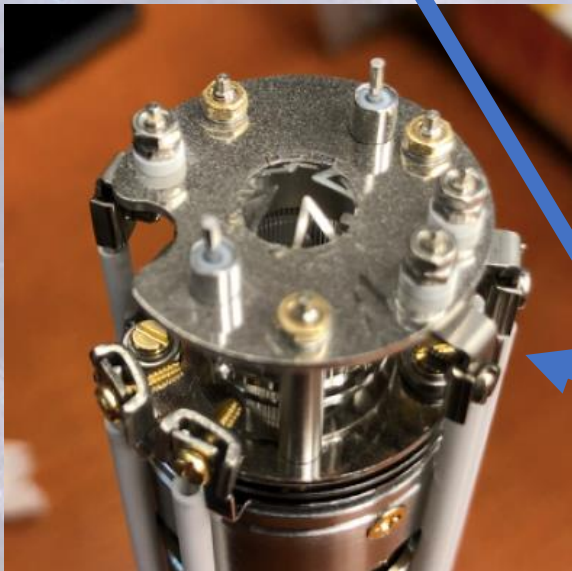

OIS covered in fine layer of simulant after eruption from soil bin, no simulant visually observed on the crossbeam



# MSolo Water Signatures (blue) and Quantification

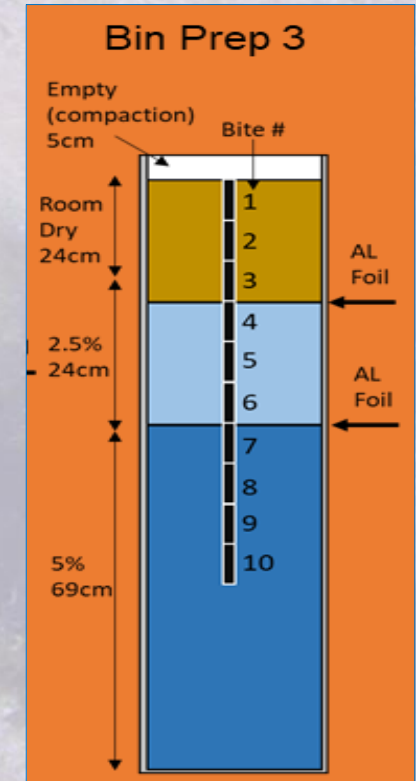
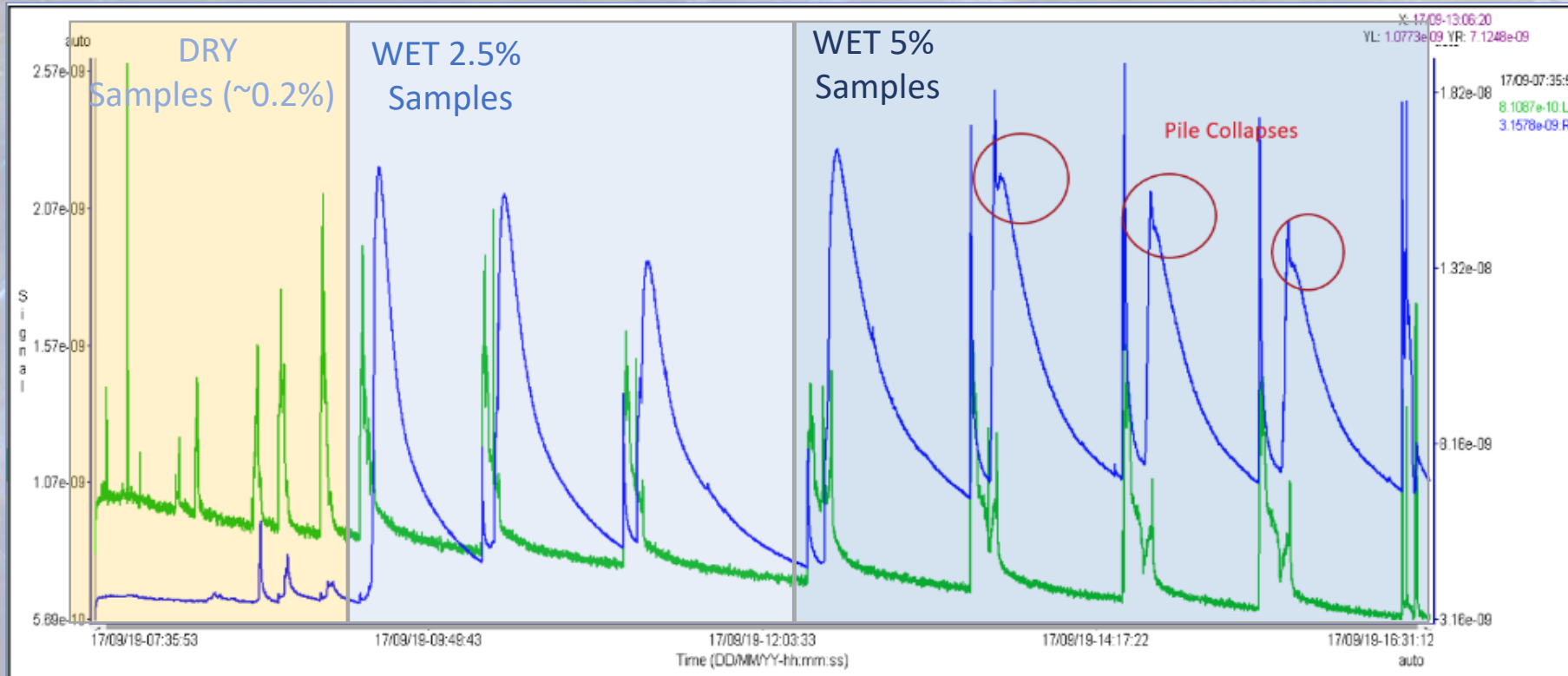

- TRIDENT Test #5 water signal correlates well with water concentration in layer: Low signal for dry layer bites, large water signals from 2.5wt% water layer and larger signals for 5wt% water in soil brought to surface.
- Pile collapses and chute interference occurs on bites 8, 9 and 10 affecting the quantification of these bites

# Long MSolo analysis time

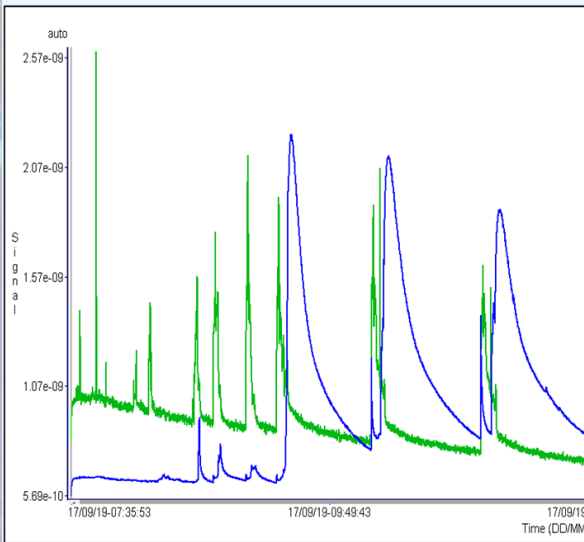

Data from TVAC tests showing water signal decay (blue).

- PRIME-1 will be able to implement a long analysis time for MSolo, looking at the water signal decay which is used to:
  - Understand the volatile diffusion and desorption informs ISRU – i.e. desorption during excavation
  - Used to verify diffusion models run under TVAC Earth based conditions and then extended to a general model to estimate Lunar soil water content
- In the VIPER mission, the timeline does not allow for the full signal decay
  - The peak intensity will be used to interpret the water estimates using the model developed with PRIME and ground test

Water Quantification Estimate:  
 Combined data set from TVAC tests shows agreement with peak water signal from all timelines, even better correlation with water flux signal.

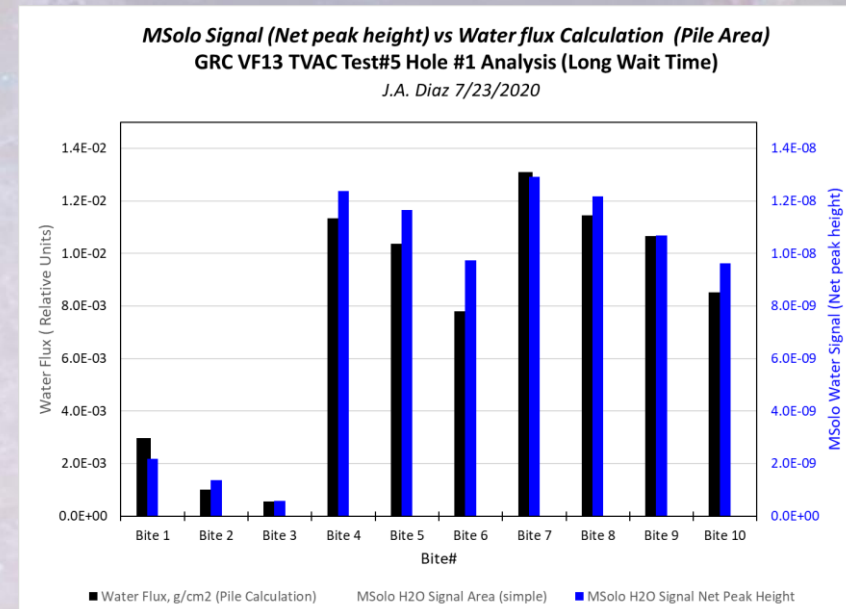

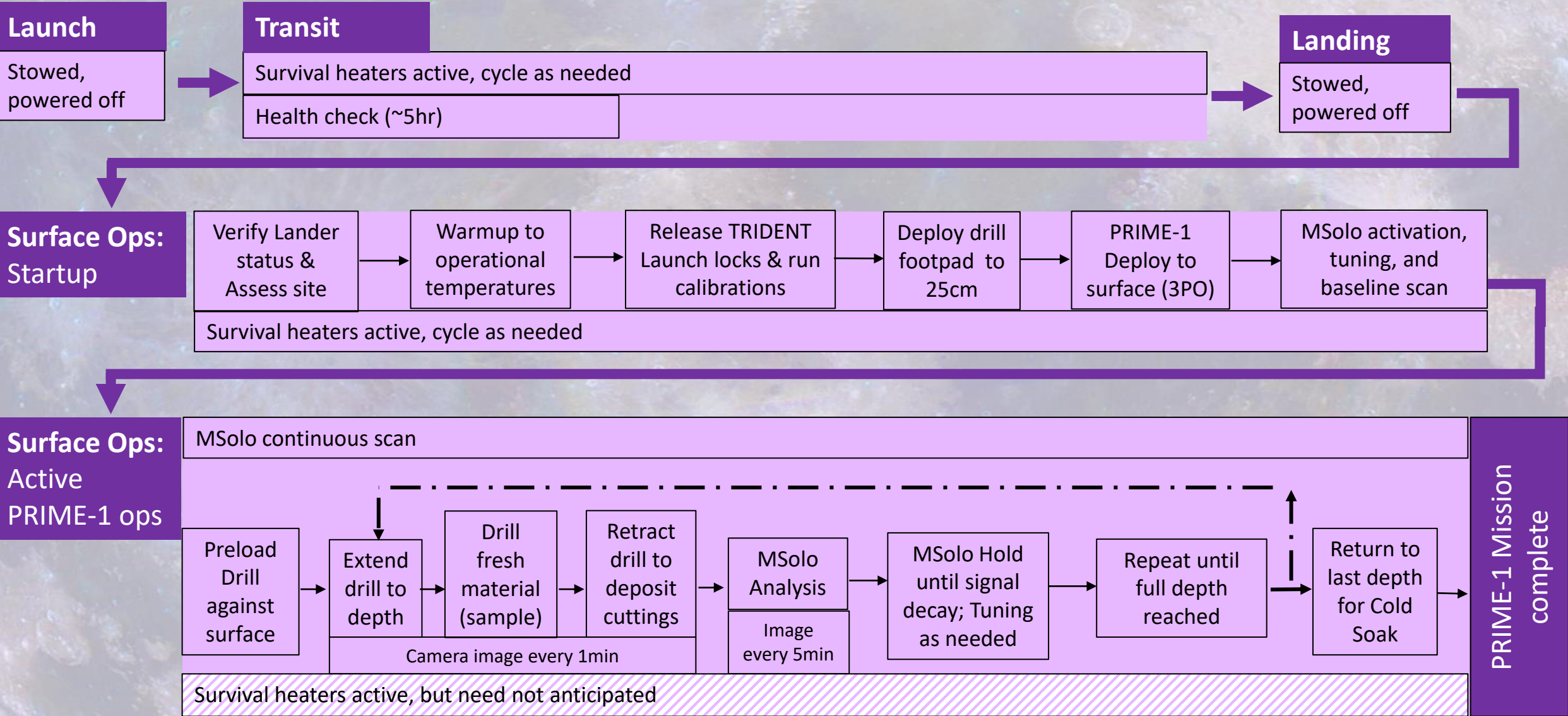

JHUAPL//01-Sep-2023 00:00:00

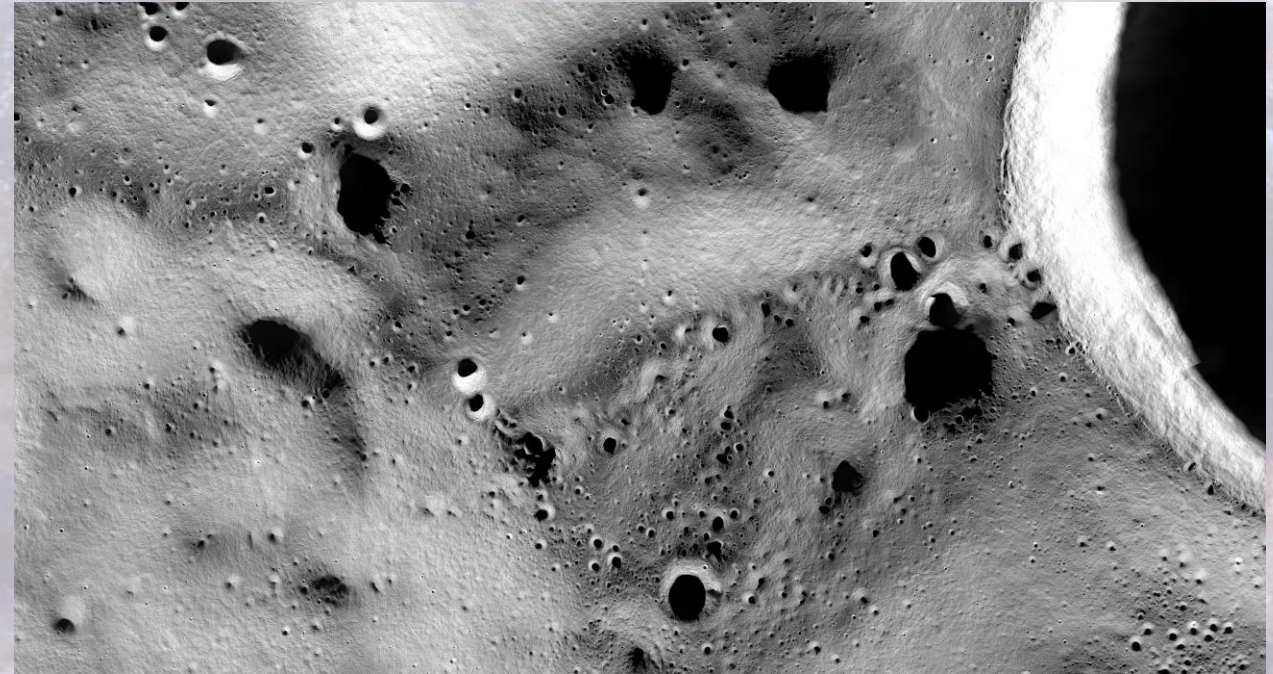

Instantaneous lighting merge mosaic created by Jeff Leeburn/APL

- Shackleton's Connecting Ridge
- Late 2023
- Falcon 9
- Intuitive Machines Nova-C Lander
- PRIME-1 payload operations approximately 72 hours in duration