



VORONOI
ALGORITHMIC
SPACE
TRANSPORT

PROF. MICHAEL FOX
MICHAELFOX@CSUPOMONA.EDU

TSBM

XHAB

vertical habitability layout
+ fabrication studies

department of architecture
at california state polytechnic
university, pomona



JPL

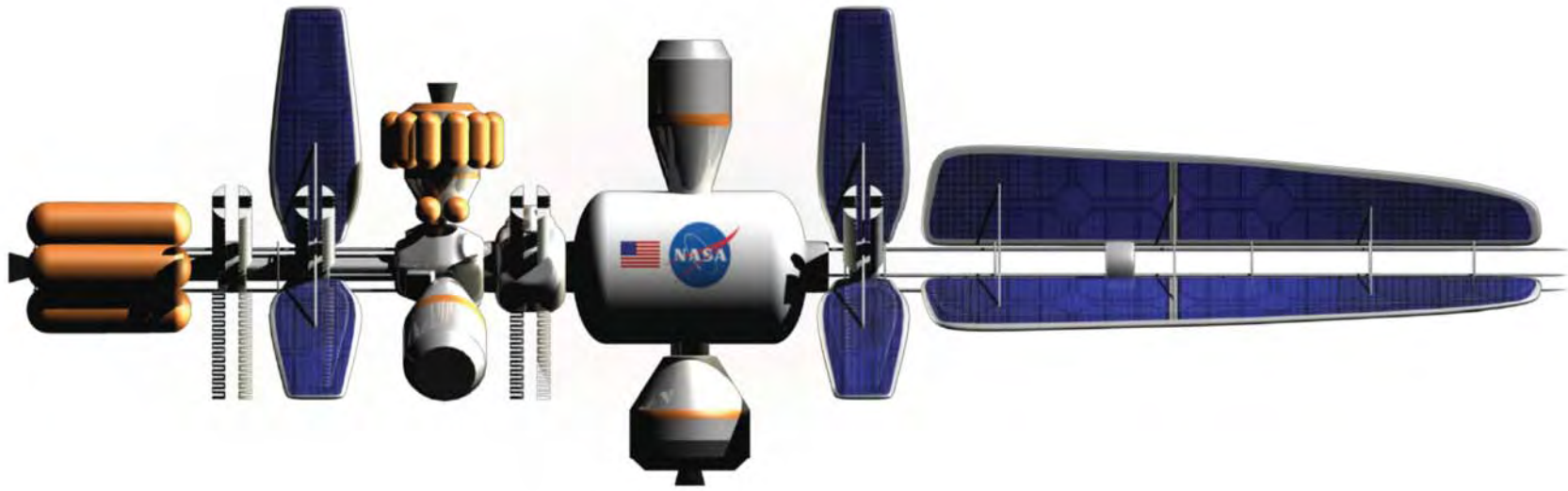

PROJECT INFO

FALL '12

WINTER '13

SPRING '13



PROJECT INFO



GOALS + OBJECTIVES
TIMELINE
G-TEAM



goals + objectives

- [] Design the interior of a vertical habitat, with a well-documented link back to the process of design (continuing the work completed the first quarter, with parametrically-derived volumes, internal layout, etc).
- [] A full-size low-fidelity 3-D spatial (mockup of the vertical habitat).

APPROACH

- [] Trade and Analysis Cycle (3-Stage):
 - [] Minimal Baseline Functionality: Core, Peripheral and Hybridized Organization
 - [] Simple Enhanced Functionality: Kinetics
 - [] Advanced Enhanced Functionality: Digital Fabrication
- [] Develop Final Vertically Oriented Deep Space Habitat Design
 - Concept:
 - [] Analyze, Evaluate, and Synthesize Concept
- [] Physical Mock-Up
 - [] Simulated Missions Testing
 - [] Digital Fabrication

timeline

[] The proposal is organized into phases correlated to the deliverables. The sequence of coursework is strategically integrated into the overall design process which includes 5 general phases that are in-line with the dates for the project review milestones set forth in the solicitation:

- 1 Background Research and Survey (Fall 2012) September 19, 2012 Requirements and Systems Definition Review
- 2 Trade and Analysis Study (Fall 2012) October 24, 2012 Preliminary Design Review
- 3 Final Design Development (BIM Model) (Fall 2012) December 05, 2012 Critical Design Review
Physical Construction Mock-up/ BIM and Physical Model Reconciliation// (Winter/Spring 2013)
- 4 February 13, 2013 Progress Checkpoint Review #1
- 5 March 15, 2013 Winter 2013 Final Review
- 6 April 3, 2013 Progress Checkpoint Review #2
- 7 May 29, 2013 Final Presentation

The screenshot displays the GTeam web interface. At the top, the browser address bar shows the URL <https://prj11.prod.gteam.com/4as6zlnwjmu/phome>. The page header includes navigation links: Xhab Studio, Khoe Huynh Tu, Account, Support, Feedback, and Sign out. Below the header, there are tabs for Activity, Files, Sync, Invite, and Settings. A left sidebar contains a 'Filter' section with options: All, Files, Sync, Downloads, Users, Messages, Comments, and Releases. The main content area is titled 'Activity' and shows a list of recent actions:

- Khoe Huynh Tu** downloaded 22 file(s) 44 minutes ago. [Add reply](#)
- Andrew Cartwright** downloaded 1 file(s) 4 hours ago. [Add reply](#)
- Andrew Cartwright** commented 18 hours ago. Comment: "Hea structural Mode guys Fox decided not to go with the pressure switch on the base so I am done with it actually added 4 more lights for more wow factor. I Can drop it off at anytime where you need it.. Let me know.. GCOD LUCK!" [Add reply](#)
- Andrew Cartwright** added Base-light.jpg 1 day ago - Last reply 1 day ago. [Add reply](#)
- Daniel Flores** added 13 files 15 days ago - Last reply 13 days ago. [Add reply](#)
- Daniel Flores** synced to the project 15 days ago. [Add reply](#)
- Daniel Flores** added 1 folder 15 days ago. [Add reply](#)

Comments on the file upload:

- Luis Sinibaldi** replied 14 days ago: "Thank you. I'm going to take a look at these. :)"
- Luis Sinibaldi** replied 14 days ago: "Images look good. I don't see the tube for the oxygen?"
- Khoe Huynh Tu** replied 13 days ago: "These renders look pretty awesome!"





FALL 2013

DESIGN DEVELOPMENT



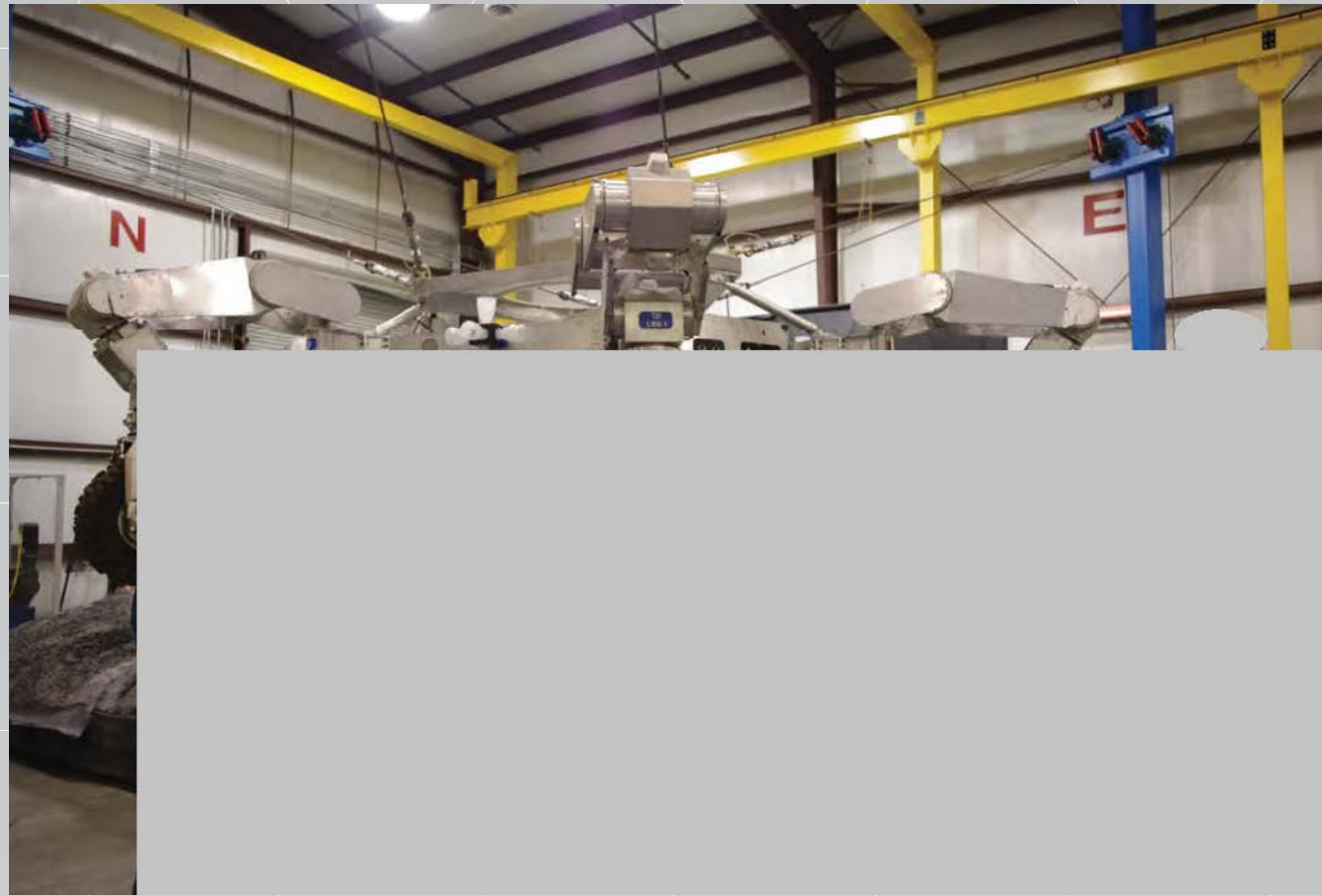

DESIGN OF A VERTICALLY ORIENTED DEEP SPACE HABITAT

LOAD: 4 ASTRONAUTS

DURATION: 60 DAY MISSION

APPROX.

DIMENSIONS: 20' DIAMETER
24' 3" HEIGHT

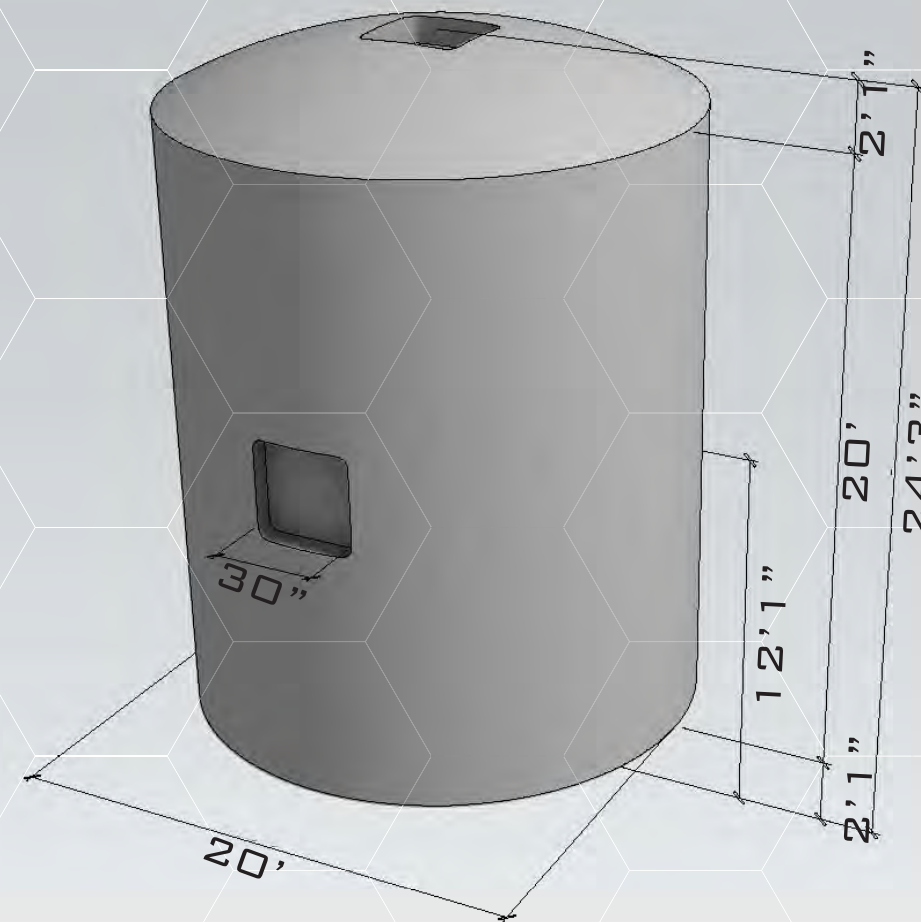

ABOVE: IMAGE TAKEN AT JPL

BELOW: IMAGE OF STUDIO SPACE (HALF HEIGHT MOCK-UP OF HAB)

FLEX HAB

MARTIN SAET

- THE HABITAT IS CONCEPTUALIZED AS A NUMBER OF FLEXIBLE VOLUMES HELD WITHIN A RIGID SHELL.
- THESE STRUCTURES ENCLOSE THE MAXIMUM POSSIBLE VOLUME WITH THE MINIMUM POSSIBLE MATERIAL
- SPACES ARE KEPT LARGE FOR THE PSYCHOLOGICAL HEALTH OF ASTRONAUTS.
- VOLUMES CAN ADJUST TO ACCOMMODATE DAY OR NIGHT ACTIVITIES.

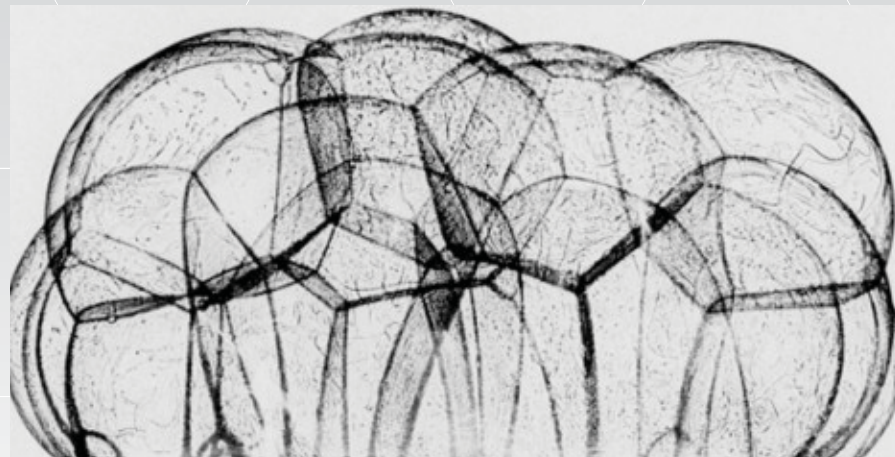
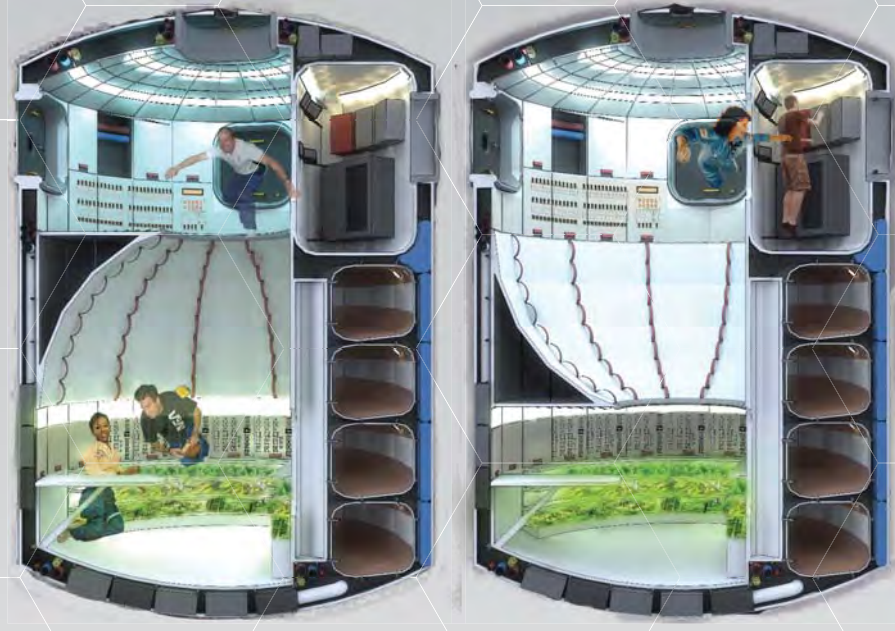
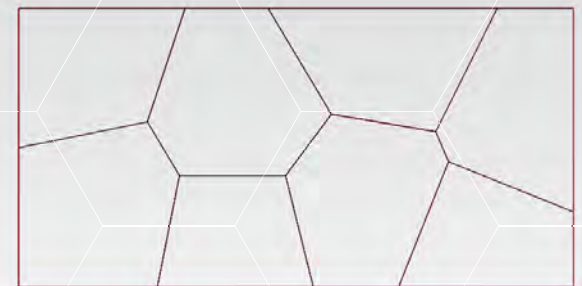
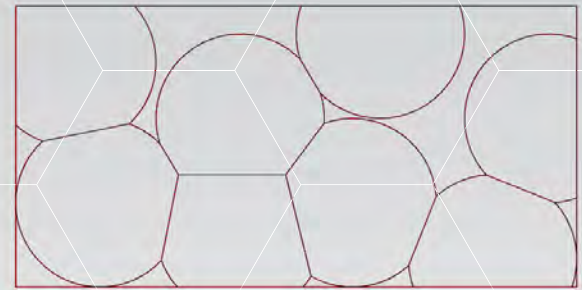

DS RIM HAB

JAMES COLTON

- INFLATABLE MEMBRANES TO CREATE POD LIKE SPACES
- RESIDUAL SPACES CREATE LARGER VOLUMES FOR USE
- ROBOTIC DEPLOYABILITY FROM A RIGID CORE MAKES THIS POSSIBLE
- THE MANIPULATION OF SPACES TO ALLOW LARGER PRIMARY VOLUMES

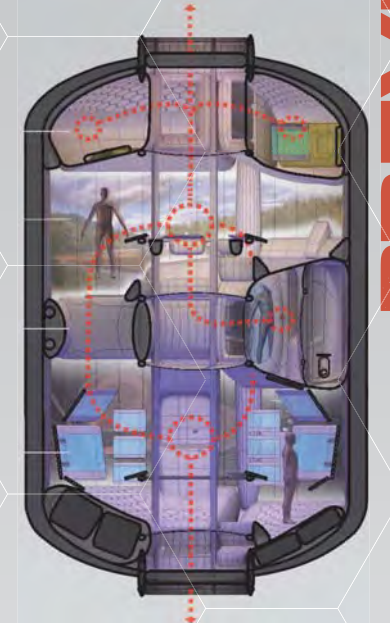
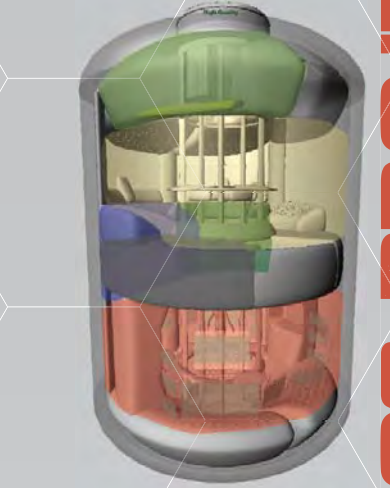
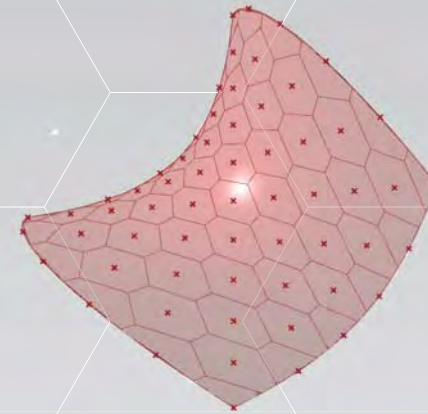

LD-TISH
AARON GOMEZ

- GOAL IS TO USE AN EFFICIENT STRUCTURE THAT WOULD CREATE A SPATIAL ORGANIZATION BUT ALSO REDUCE COST.
- THUS PROVIDING AN INEXPENSIVE AND EASILY REPRODUCIBLE SYSTEM WHICH CAN ALSO CREATE MANY DIFFERENT CONFIGURATIONS.

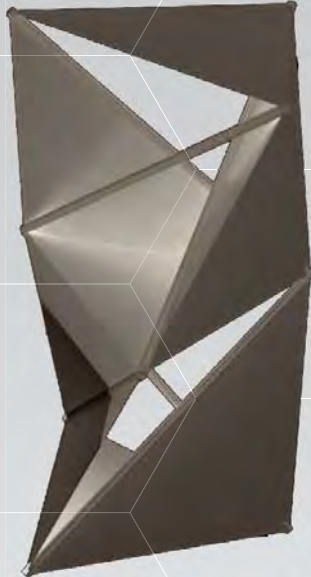
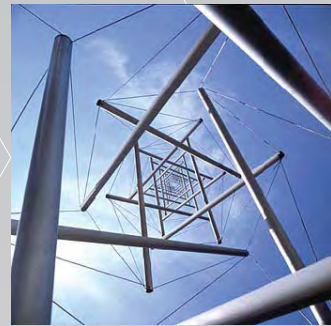

SPACE HABITATION
JASON FRIEDRICH

- A VARIABLE INTERIOR WHICH RESPONDS TO THEIR NEEDS WHETHER IT IS OVER TIME OR FUNCTION BECOMES A NECESSITY
- ROTATION OF THE CORE IS CONVERTED TO TELESCOPING ACTION AT ONE END DRIVING THE VARIABLE PROGRAMMATIC ELEMENTS

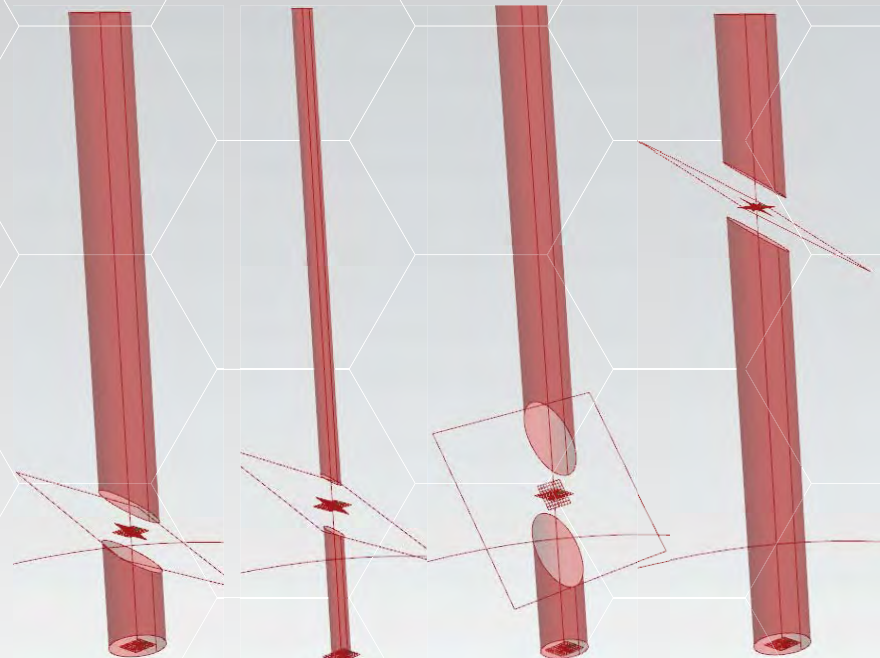
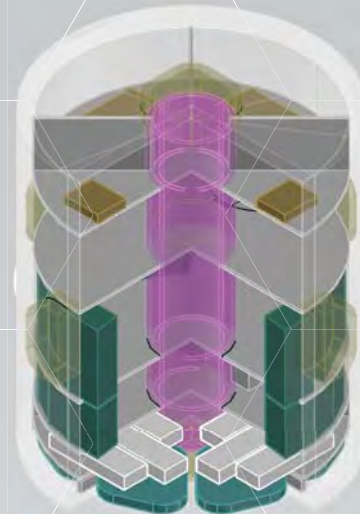
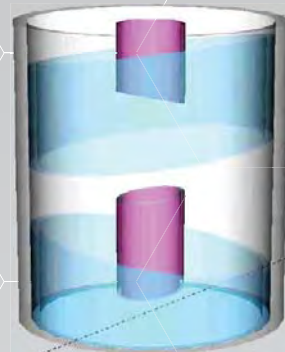

LRV
ANDREW CARTWRIGHT

- THE DESIGN PROCESS CONSISTED BY ANALYZING THE LAGRANGIAN POINTS FOR SPATIAL AND ORGANIZATIONS PRINCIPALS.
- THE LAGRANGIAN POINTS REPRESENT THE IDEA OF BALANCE OF UNEQUAL PARTS WHICH IN SENSE RELATES TO THE IDEA OF EQUILIBRIUM
- THE SPATIAL CHARACTERISTICS OF THE VOLUMES GAVE RISE TO A UNIQUE DUAL SPATIAL ENVIRONMENT.

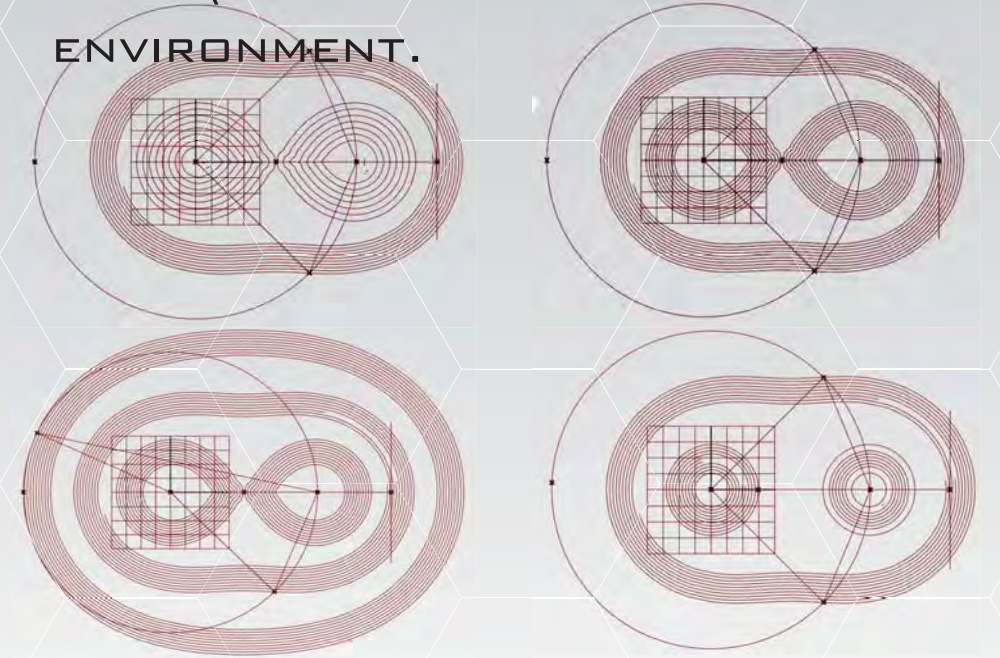
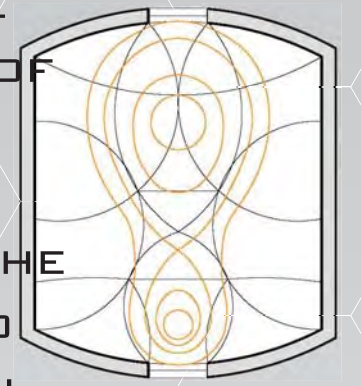
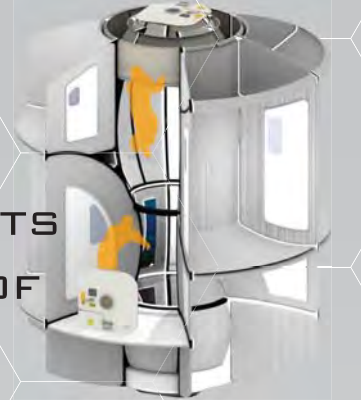
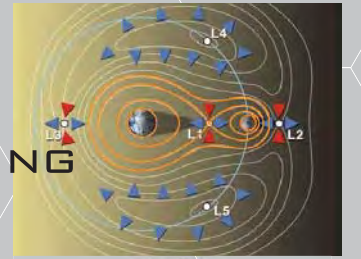

FML HAB

KEN LEE

- MODULAR DESIGN ALLOWS FOR AN OPTIMAL CONSIDERATION IN BOTH VOLUME BASED SPACES AND SURFACE BASED SPACES. DUE TO THE ZERO G CONDITIONS OF SPACE, BOTH TYPES OF SPACES ARE NEEDED.
- MODULAR SYSTEM SET UP A PRECEDENCE WHICH ALLOWS THE INHABITANTS TO EDIT OR READJUST AS THE MISSION CONTINUES



SHELS

JENA CARDENAS

- CREATION OF A VARIETY OF SPACE TO ALLOW FOR DIFFERENT LEVELS OF PRIVACY AS WELL AS DIFFERENT SIZED SPACES.
- ACCOMMODATES DIVERSE PROGRAMMATIC FUNCTIONS SUCH AS PRIVATE CREW QUARTERS VS. COLLABORATIVE WORKING ENVIRONMENT.
- ALLOWS THE CREW TO EXPERIENCE A VARIETY OF SPACE ON A LONG MISSION IN A SMALL ENCLOSED SEMI-PUBLIC ENVIRONMENT.

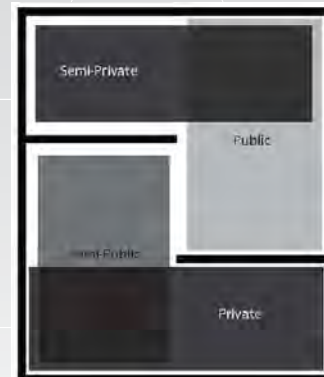
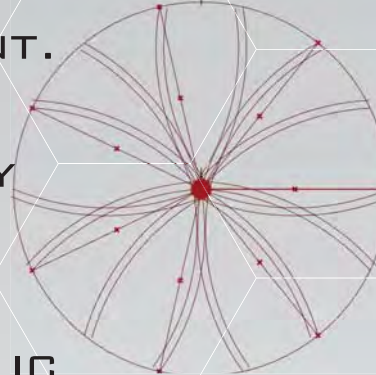
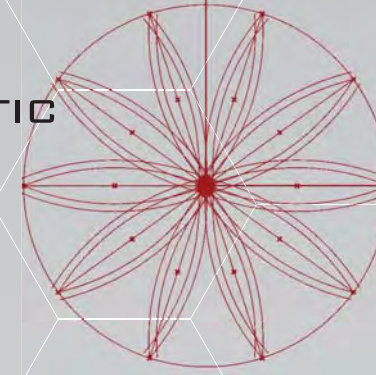
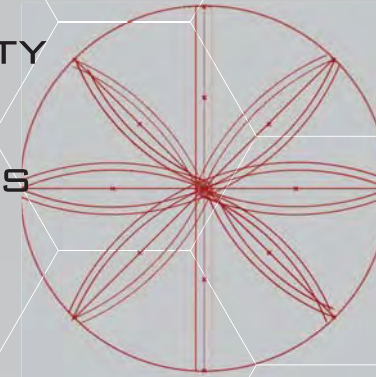

THE KAV HAB

VERONICA HERNANDEZ

- THE CIRCULATION TORUS CONNECTS ALL OF THE DIFFERENT MODULES THAT THE CREW NEEDS TO USE TO WORK, PLAY, SLEEP, AND CLEAN.
- THE CAPSULE IN THE CENTER WOULD EXPAND AND COLLAPSE BASED ON THE FUNCTIONAL NEED BY THE CREW MEMBERS AT DIFFERENT TIMES OF THE DAY.

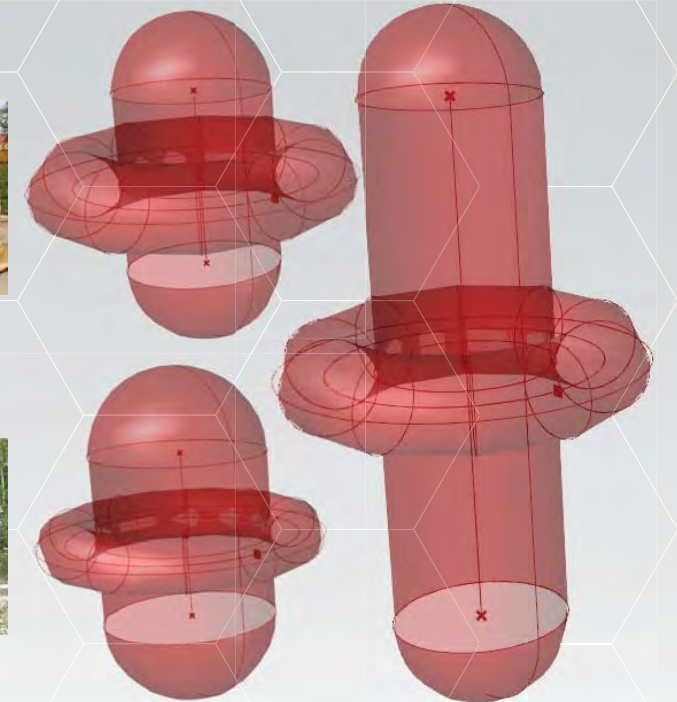

NON-TRADITIONAL WORKFLOW

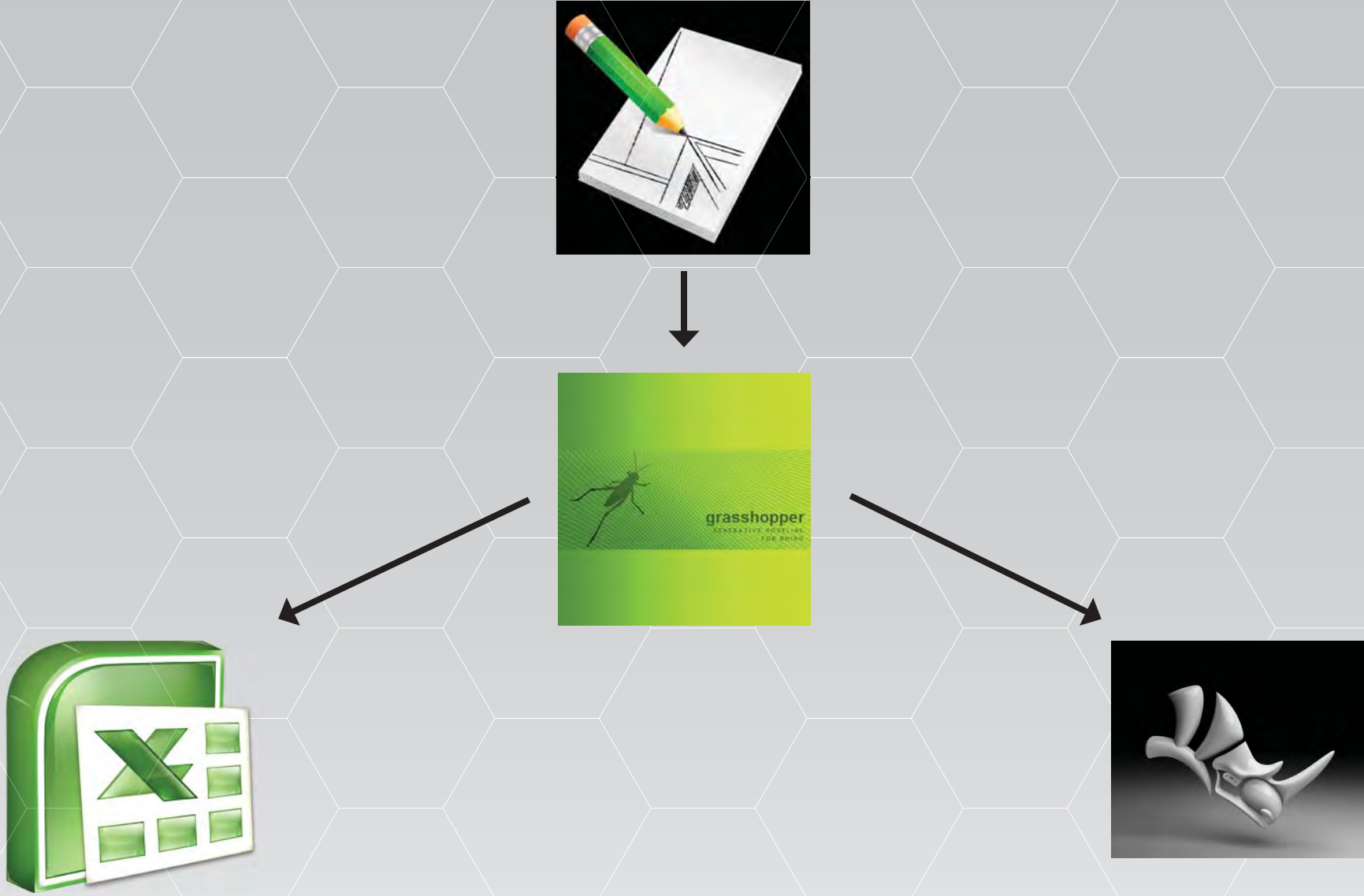

OUR APPROACH: OVERVIEW

SKETCH:

A HAND DRAWING METHOD THAT
ALLOWS FOR EXPLORATION OF
INITIAL DESIGN IDEAS.

USED FOR SCHEMATIC DESIGN.
OR IN THE CASE OF THIS PROJECT
TAKEN FROM PREVIOUS PROJECT
VARIATIONS EXPLORED DURING
INITIAL INDIVIDUAL DESIGN PHASE
OF PROJECT.

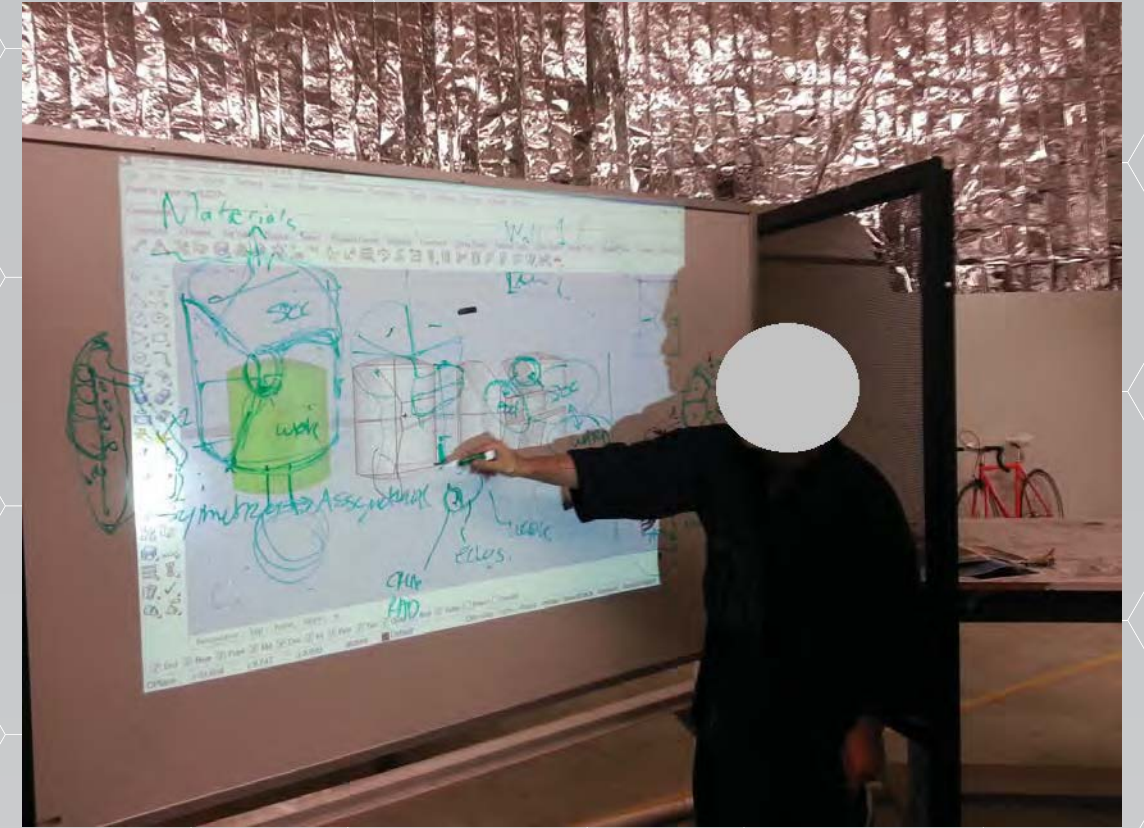

GRASSHOPPER:

A VISUAL PROGRAMMING LANGUAGE DEVELOPED BY DAVID RUTTEN.

USES A SERIES OF LINKED ALGORITHMIC COMPONENTS THAT RESULT IN 3D PARAMETRIC GEOMETRY VISUALIZED IN RHINOCEROS 3D.

USED FOR CREATING QUICK VISUAL VARIATIONS OF SCHEMES FOR THE PROJECT.

VARIOUS PLUG-IN ARE AVAILABLE THAT CAN BE USED TO OPTIMIZE AND TEST THE DESIGN. FOR EXAMPLE MILLIPEDE IS A PLUG IN THAT ALLOWS FOR OPTIMIZATION OF SPACES AND SURFACE AREAS.

[HTTP://WWW.GRASSHOPPER3D.COM/](http://www.grasshopper3d.com/)

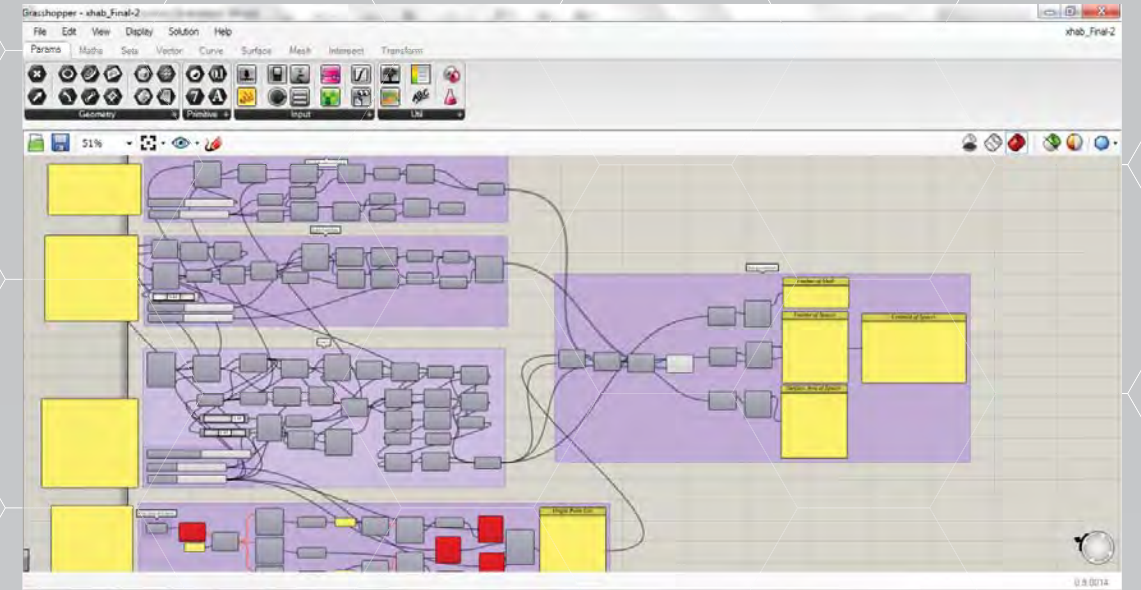

EXCEL:

A SPREAD SHEET APPLICATION THAT ALLOWS DATA IMPUTE AND COMPARISONS IN GRAPHIC FORM.

USED FOR OUTPUT OF DATA FROM GRASSHOPPER THAT ALLOW COMPARISONS OF SCHEMATIC VARIATIONS. THIS INCLUDES VOLUME, MASS, AND SURFACE AREA DATA THAT IS EXTRACTED FROM THE 3D MODEL.

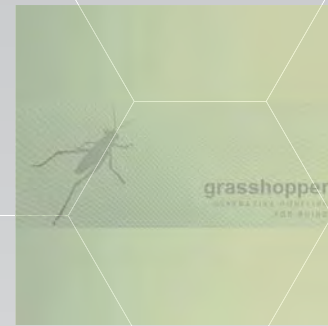
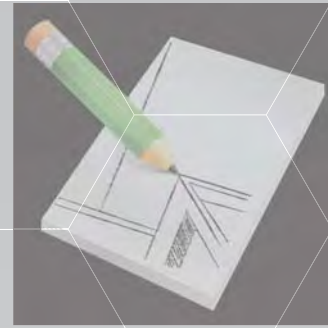

Interior Space 1	Interior Space 2	Interior Space 3
Total Surface Area: 712.9 ft ²	Total Surface Area: 280.7 ft ²	Total Surface Area: 280.7 ft ²
Percentage of Wall Type: Structural: 40% Interior: 60%	Percentage of Wall Type: Structural: 40% Interior: 60%	Percentage of Wall Type: Structural: 50% Interior: 50%
Total Weight of Walls: 2119.197383 lbs	Total Weight of Walls: 827.4568167 lbs	Total Weight of Walls: 769.2115667 lbs
Total Cost of Walls: \$ 4,008.47	Total Cost of Walls: \$ 1,565.14	Total Cost of Walls: \$ 1,558.12
Volume of Wall: 67.89641967 ft ³	Volume of Wall: 28.43258333 ft ³	Volume of Wall: 25.73083333 ft ³
Volume of Space: 2494.201583 ft ³	Volume of Space: 408.5674167 ft ³	Volume of Space: 409.2691667 ft ³

Interior Space 4	General Information	Interior Space 5
Total Surface Area: 354.9 ft ²	Grand Total Weight: 9695.681917 lbs	Total Surface Area: 354.9 ft ²
Percentage of Wall Type: Structural: 40% Interior: 60%	Grand Total Cost: \$ 18,618.25	Percentage of Wall Type: Structural: 40% Interior: 60%
Total Weight of Walls: 1046.18605 lbs	Structural Wall Percentage: 42.50%	Total Weight of Walls: 1046.18605 lbs
Total Cost of Walls: \$ 1,978.86	Interior Wall Percentage: 57.50%	Total Cost of Walls: \$ 1,978.86
Volume of Wall: 33.41975 ft ³	Total Volume of Wall: 312.3550533 ft ³	Volume of Wall: 33.41975 ft ³
Volume of Space: 641.58025 ft ³	Total Volume of Space: 8029.144917 ft ³	Volume of Space: 641.58025 ft ³

Interior Space 6	Interior Space 7	Interior Space 8
Total Surface Area: 478.1 ft ²	Total Surface Area: 164.3 ft ²	Total Surface Area: 683.5 ft ²
Percentage of Wall Type: Structural: 50% Interior: 50%	Percentage of Wall Type: Structural: 40% Interior: 60%	Percentage of Wall Type: Structural: 40% Interior: 60%
Total Weight of Walls: 1310.153167 lbs	Total Weight of Walls: 544.7596 lbs	Total Weight of Walls: 2032.531083 lbs

RHINOCEROS 3D:

A NURBS-BASED 3D GRAPHIC MODELING SOFTWARE DEVELOPED BY ROBERT MCNEEL. NURBS, ALSO KNOWN AS NON-UNIFORM RATIONAL BASIS SPLINE A MATHEMATICAL MODEL THAT IS USED TO GENERATE REPRESENTATIVE CURVES AND SURFACES.

USED TO “BAKE” GEOMETRY FROM GRASSHOPPER AND CREATE “DUMB” GEOMETRY THAT IS STATIC. CONCRETE POINTS CAN THEN BE USED FOR 3D MODELING IN WHICH THICKNESS CAN BE APPLIED TO THE GEOMETRY AND RENDERINGS CAN BE MADE. CAN ALSO BE USED TO EXTRACT POINTS TO BE MODELED IN AUTODESK REVIT OR OTHER MODELING SOFTWARE.

[HTTP://WWW.RHINO3D.COM/](http://www.rhino3d.com/)

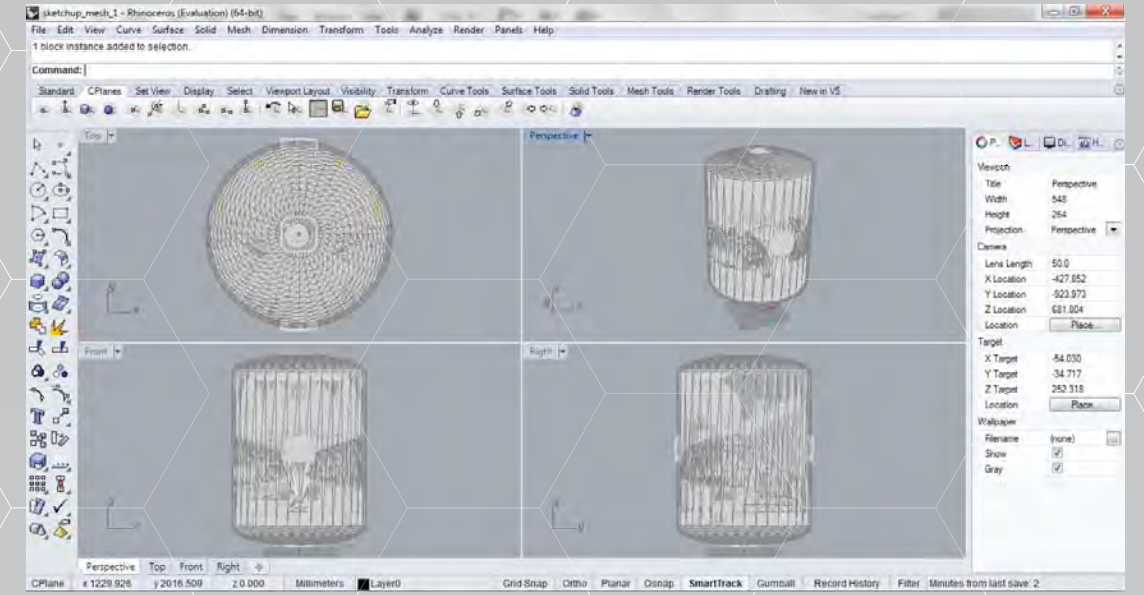

G-TEAM

A GEHRY TECHNOLOGIES ONLINE COLLABORATIVE INTERFACE.



ONLINE MODEL VIEWER, FILE SHARING AND CHAT FUNCTIONS. ADD SUMMARY, REVISION HISTORY.



COMPARED TO FACEBOOK/DROPBOX BUT FOR ARCHITECTS.

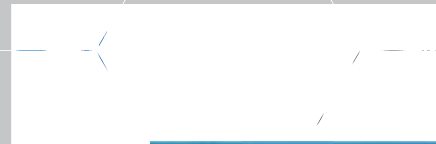

GEHRY TECHNOLOGIES

OUR APPROACH: DETAILED

CONCEPT

PARTI

ORGANIZATION

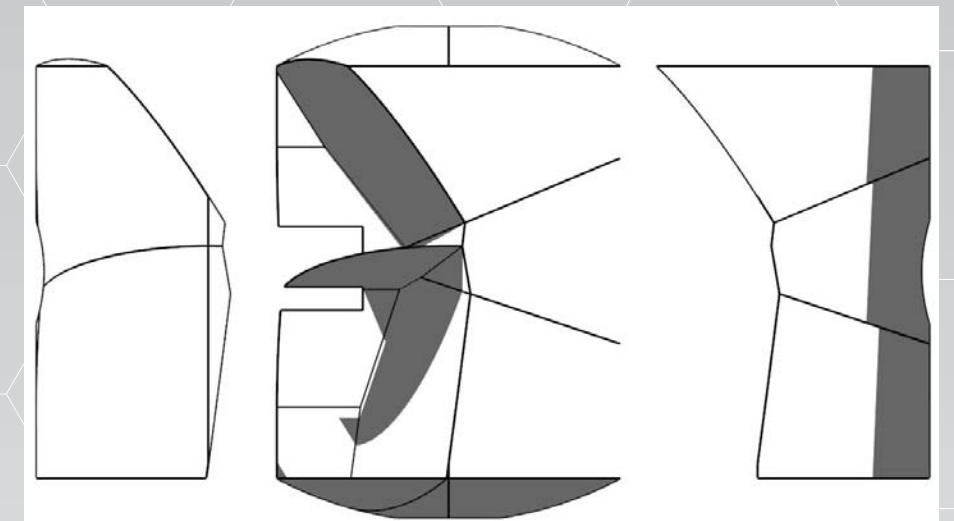
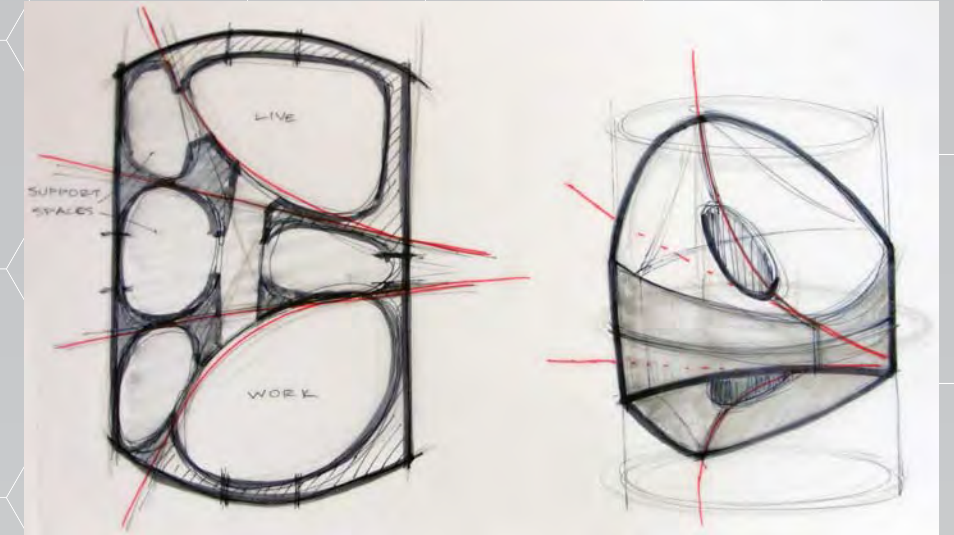
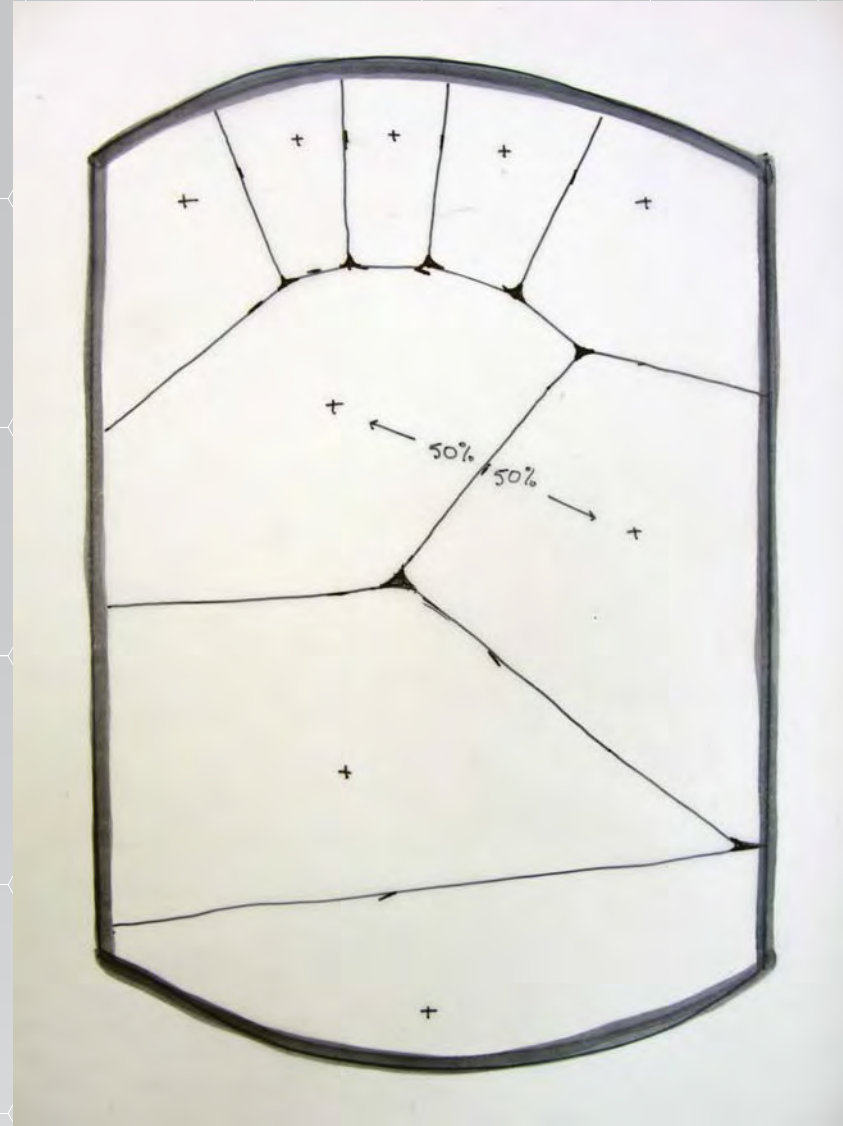
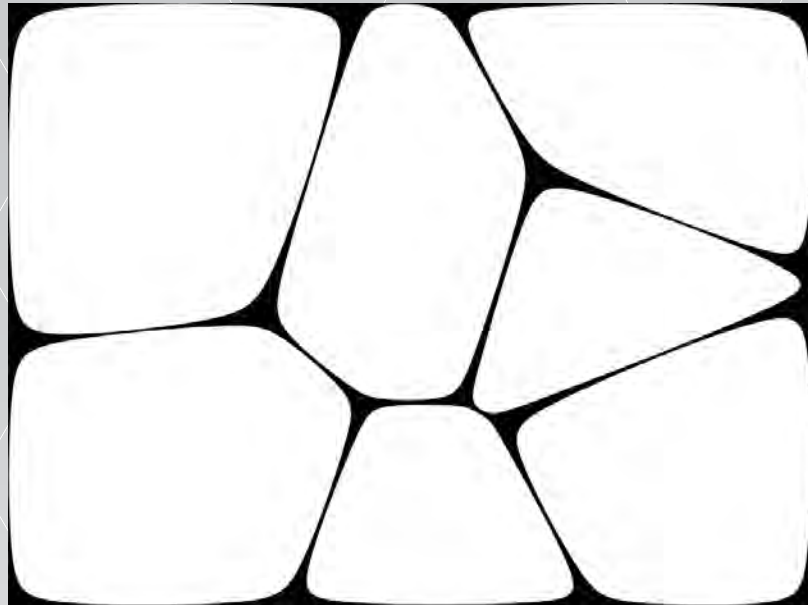
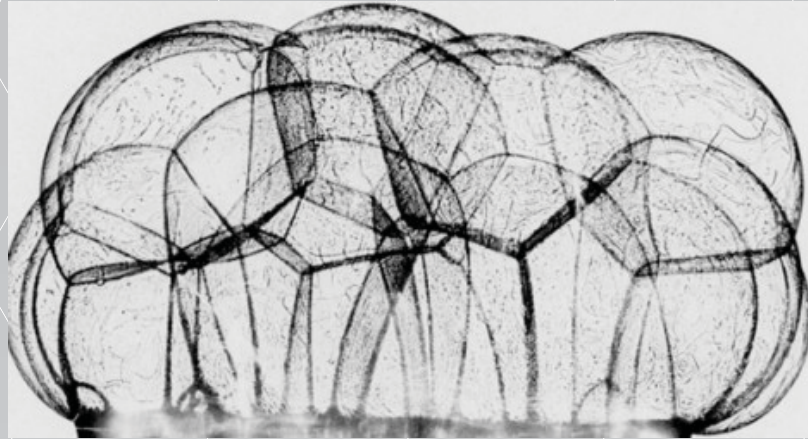

SOAP BUBBLES AND VORONOI DIAGRAMS ARE SYSTEMS BASED ON MATHEMATICAL, PARAMETRIC RULES. BOTH SYSTEMS OPTIMIZE BOUNDARIES BETWEEN SPACES.

WE START OUR DESIGN PROCESS WITH CONCEPT SKETCHES AND ANALYSIS OF PREVIOUS DESIGNS TO FIND A SET OF POINTS. BY INPUTTING THESE POINTS INTO A VORONOI SCRIPT, WE GENERATE A SET OF SPACES THAT ENCLOSE THE MAXIMUM POSSIBLE VOLUME WITH THE LEAST POSSIBLE MATERIAL.

ALTHOUGH OUR CONTROL OF THE FINAL CONCEPT IS INDIRECT, THE GRASSHOPPER WILL ALWAYS PRODUCE AN EFFICIENT SOLUTION TO THE POINTS WE GIVE IT.

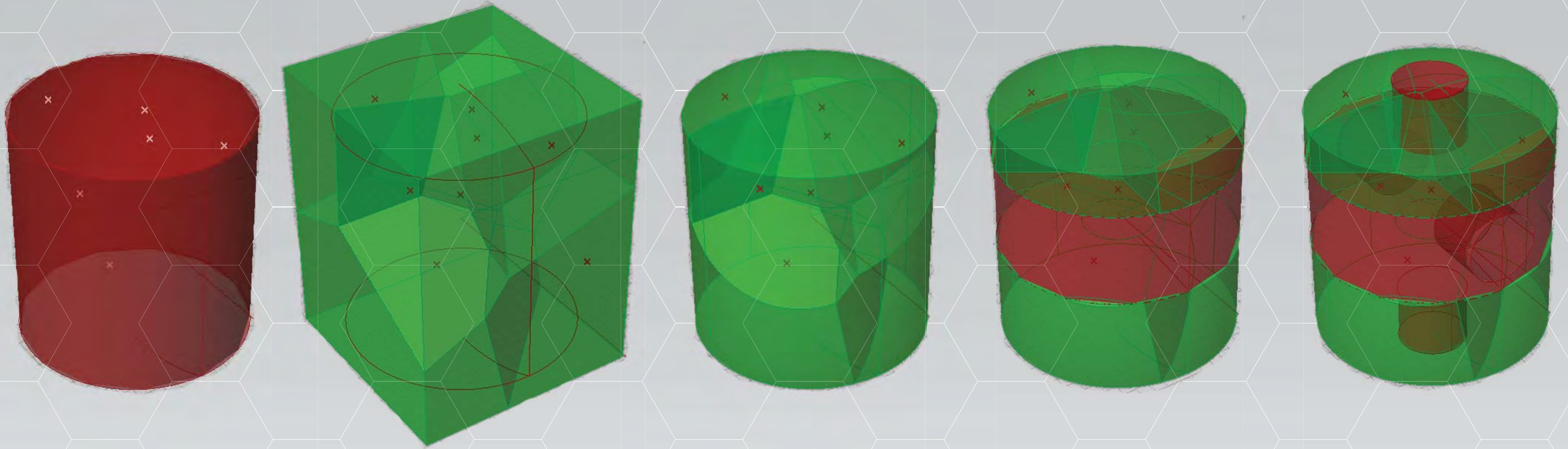

USE OF A PURELY VORONOI ORGANIZATION IN EXPLORING THE HABITAT DESIGN.

SPACES BECOME MORE HABITABLE, HOWEVER, DIFFICULT TO CONTROL POINTS TO MAKE NECESSARY SPACES BECAUSE OF THE NATURE OF THE VORONOI EQUATION.

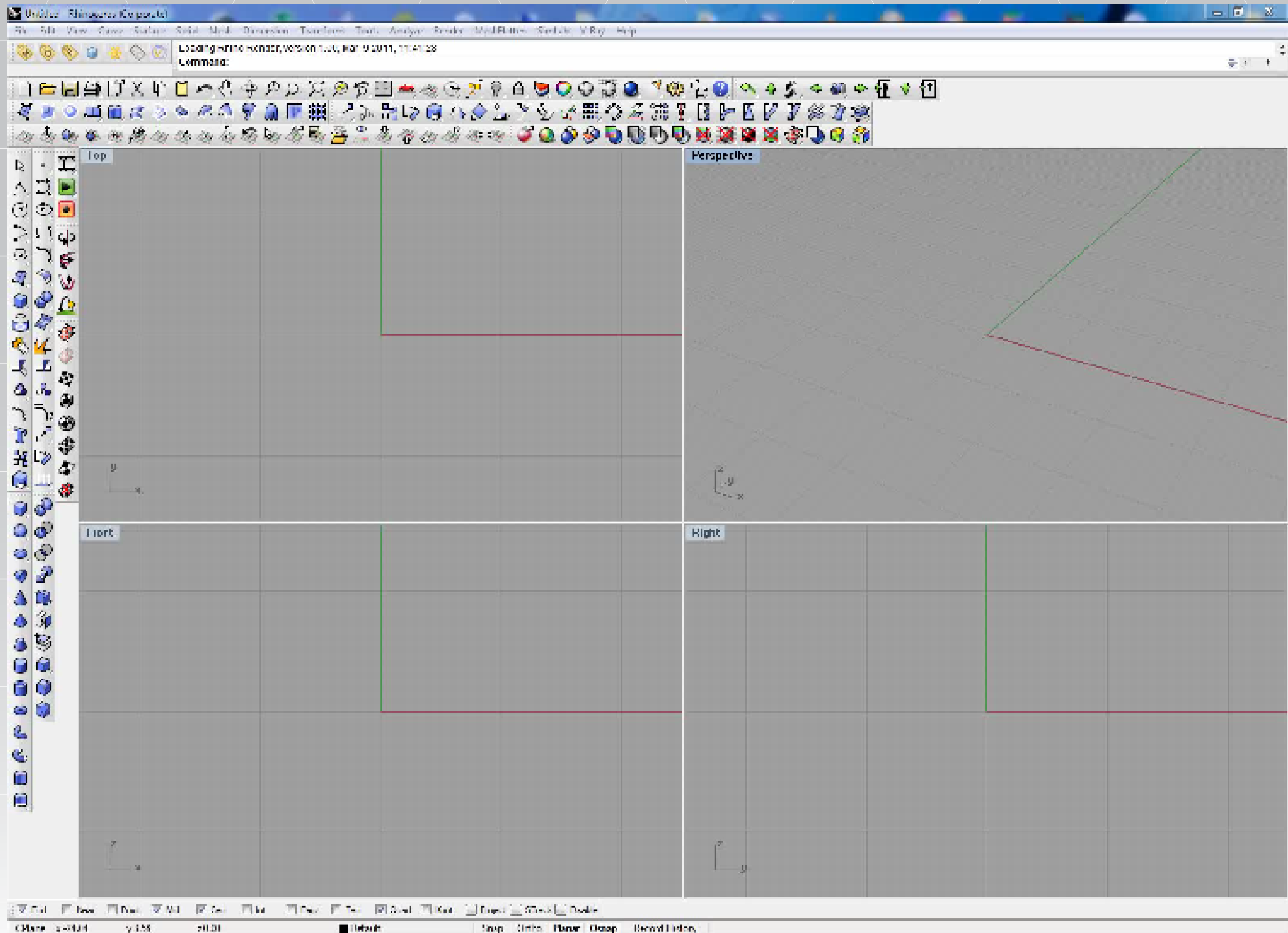

OUR APPROACH: DETAILED

GRASSHOPPER:

UTILIZING HIERARCHY OF CONSTRUCTING THE HAB WITHIN GRASSHOPPER.

MOST ARE DEPENDENT ON ONLY 3 FACTORS

1. INNER SHELL RADIUS
2. INNER SHELL HEIGHT
3. CAP RADIUS

*D (DEPENDENT FACTOR)

THE WORKFLOW OF THE HAB AS FOLLOWS
INNER SHELL

- A. RADIUS
- B. HEIGHT
- C. CAP RADIUS

TOP & SIDE HATCHES

- A. RADIUS
- B. DEPTH
- C. POSITION (D)
- D. ROTATION

OUTER SHELL

- A. THICKNESS

SPATIAL POINTS

- A. EXCEL LINK
- B. X,Y,Z VALUES PERCENTAGE (D)

VORONOI

- A. ALL FACTORS ARE DEPENDENT ON ALL OTHER FACTORS ABOVE.

DESIGN IS DYNAMIC AND NOT DEPENDANT ON A UNIT OR KNOWN SPATIAL POSITION.

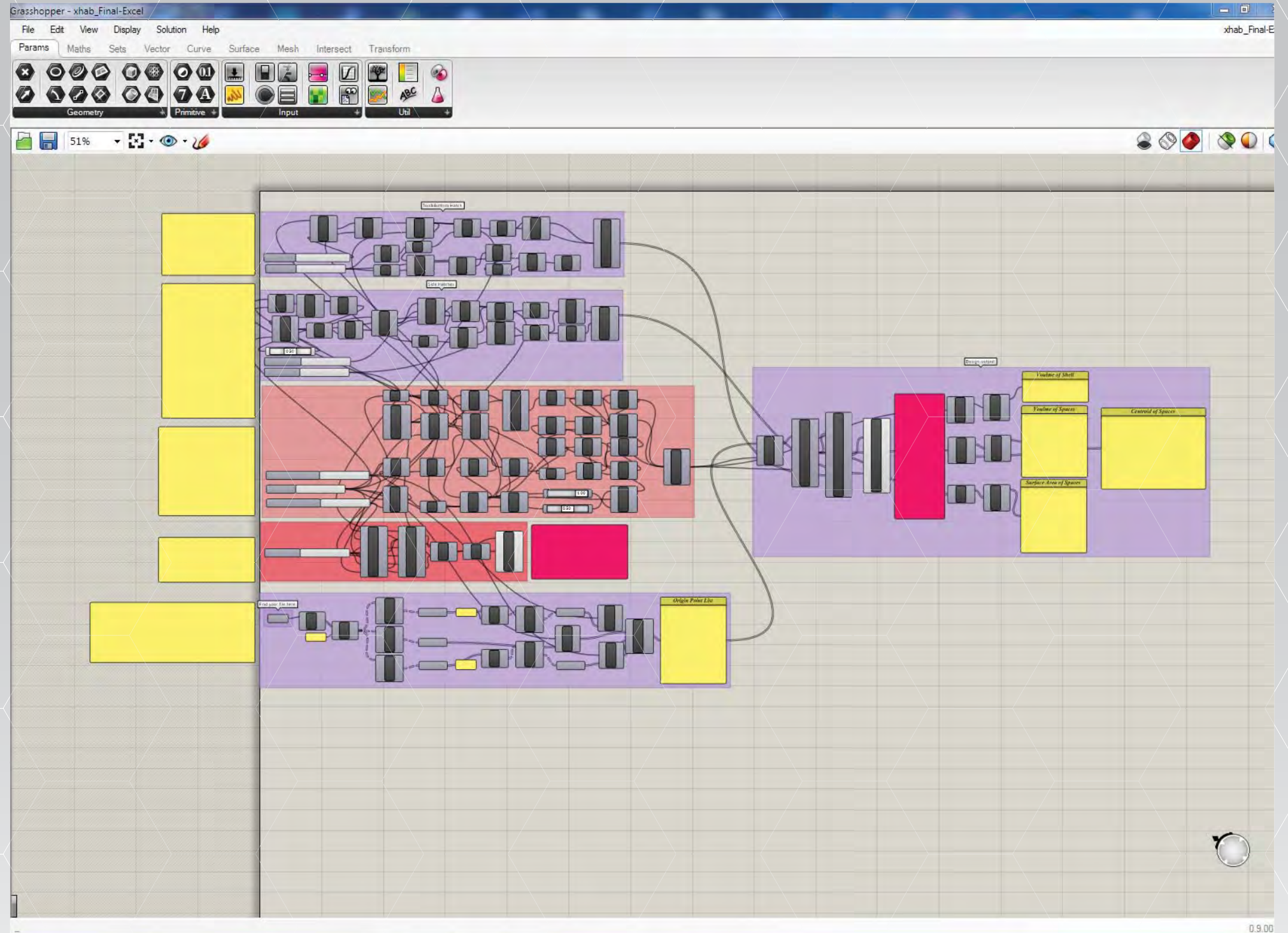

Change the Shell Height, Radius, and Cap height As needed.
 Default
 Cap 25%
 Height 12 feet
 Radius 10 feet

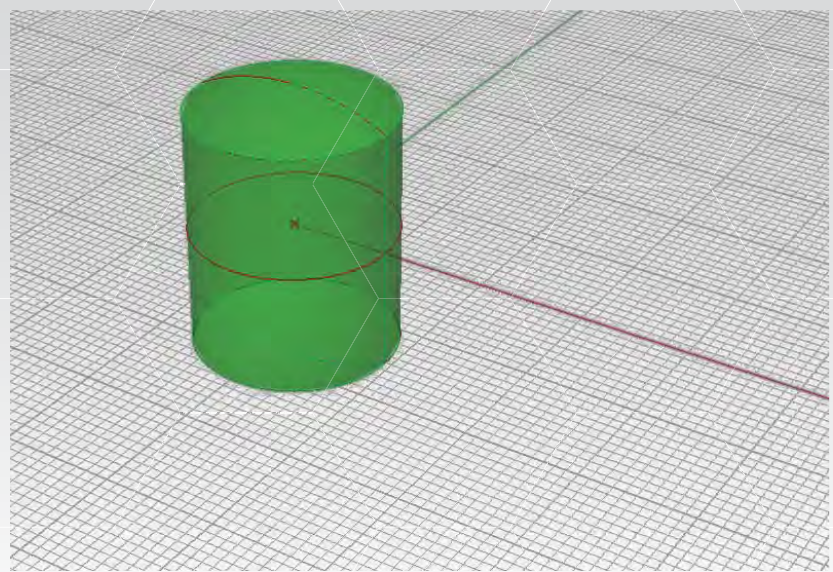
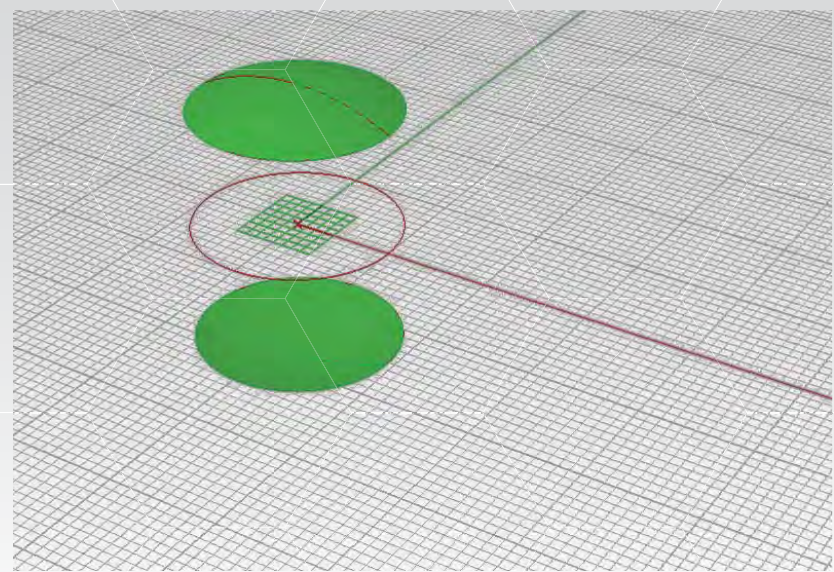
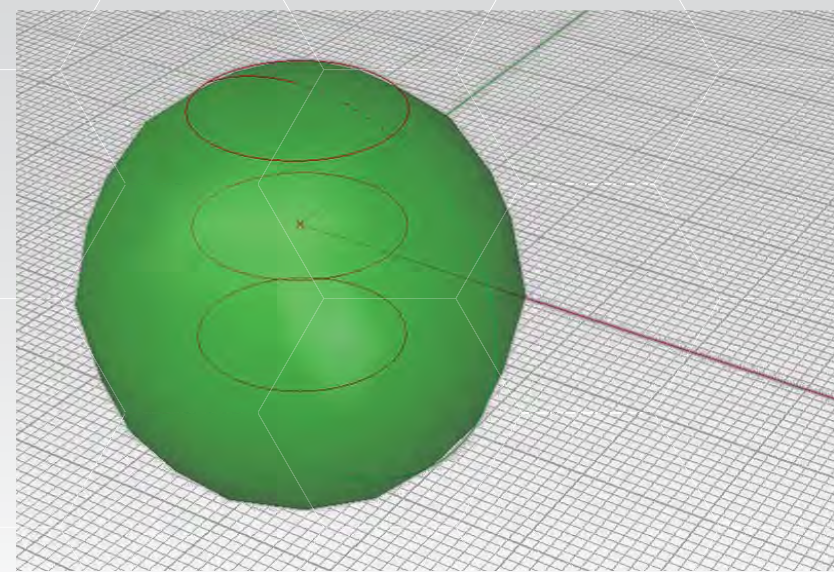
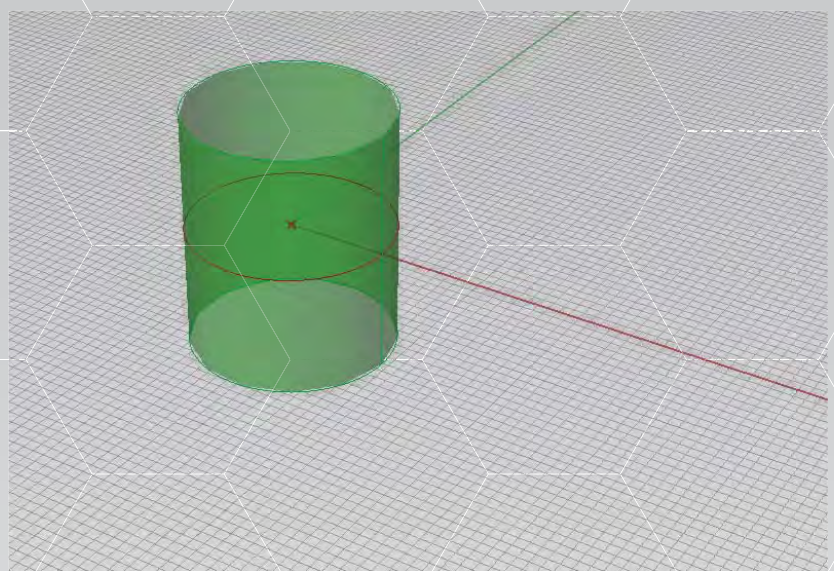
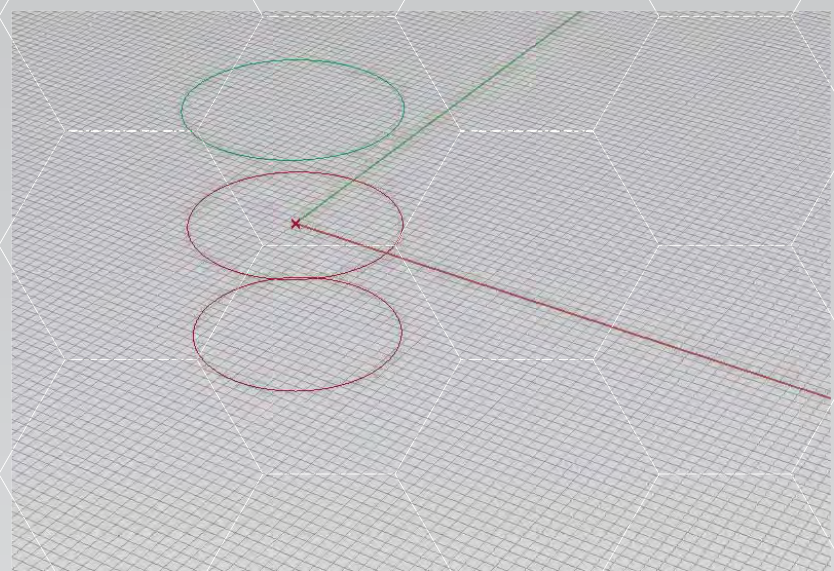
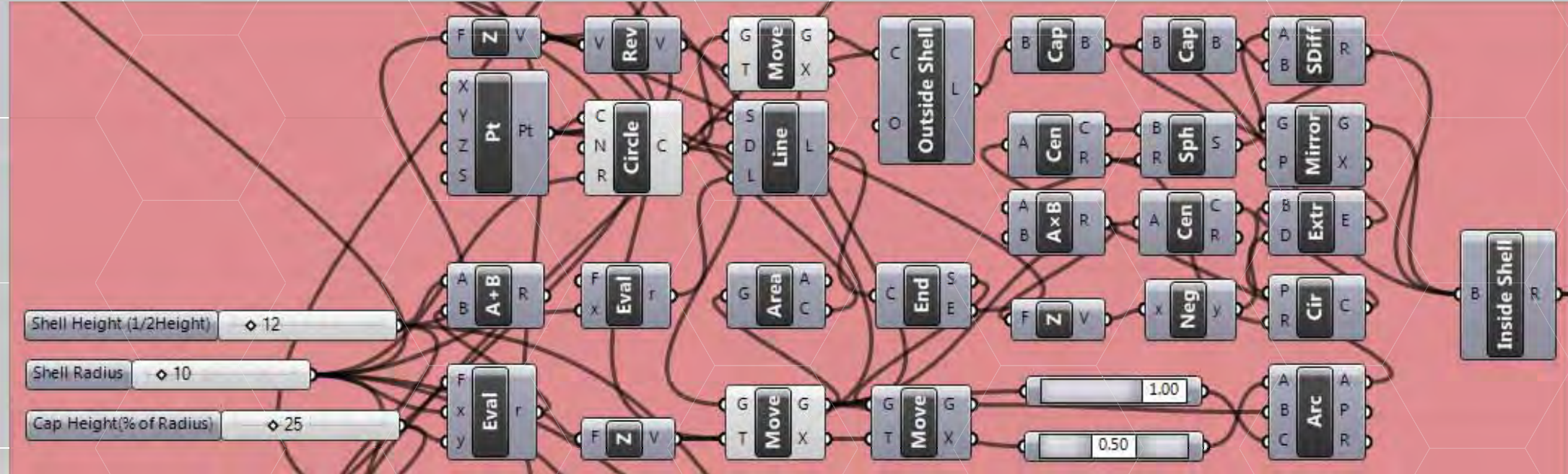

OUR APPROACH: DETAILED

Change Hatch Depth & Radius as Needed..
 Default is Radius 3 Feet, Depth 5 feet

Right Click on top Slider for range of Hatch Position

Slide Bottom slider for Rotation

Default 1/2 (0.50), 3 Feet, 90 Degrees

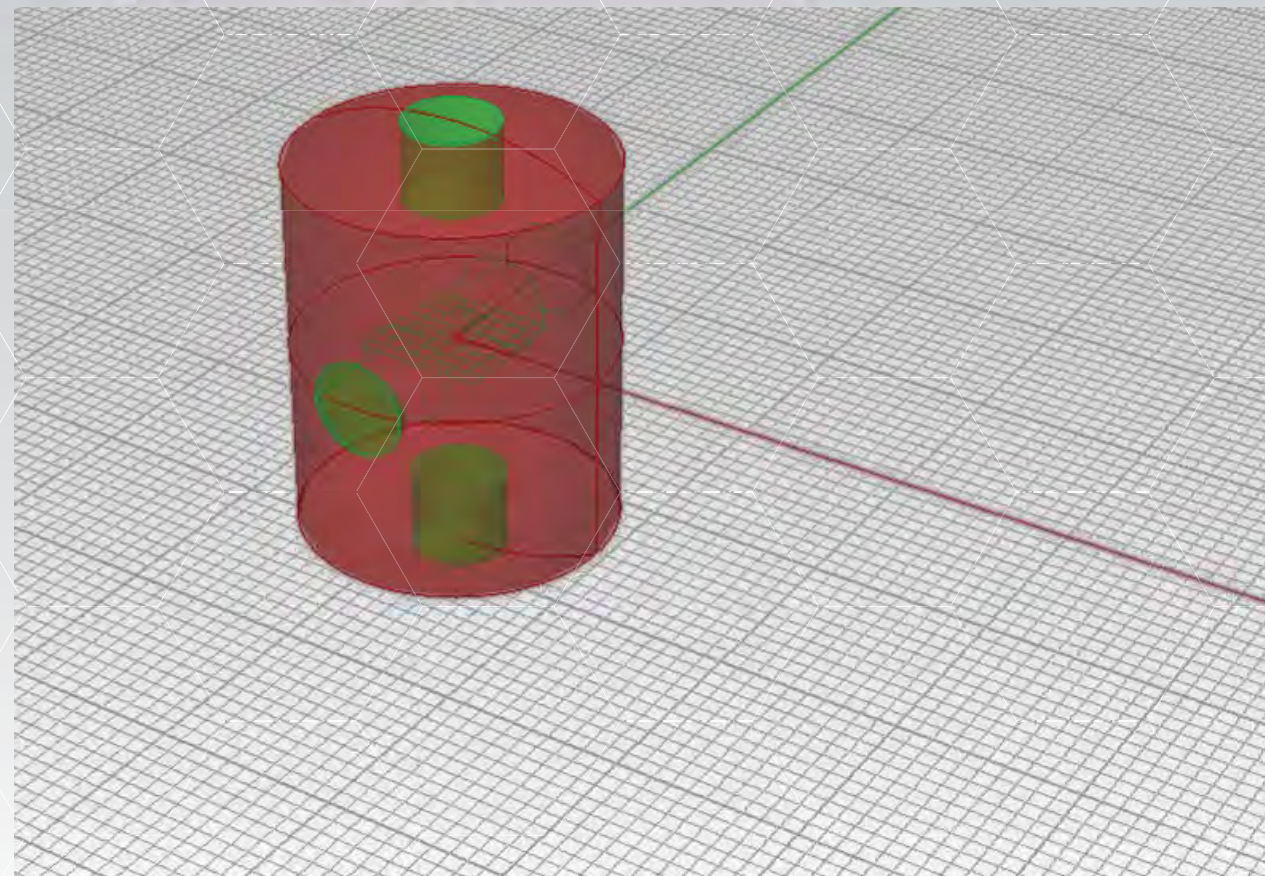
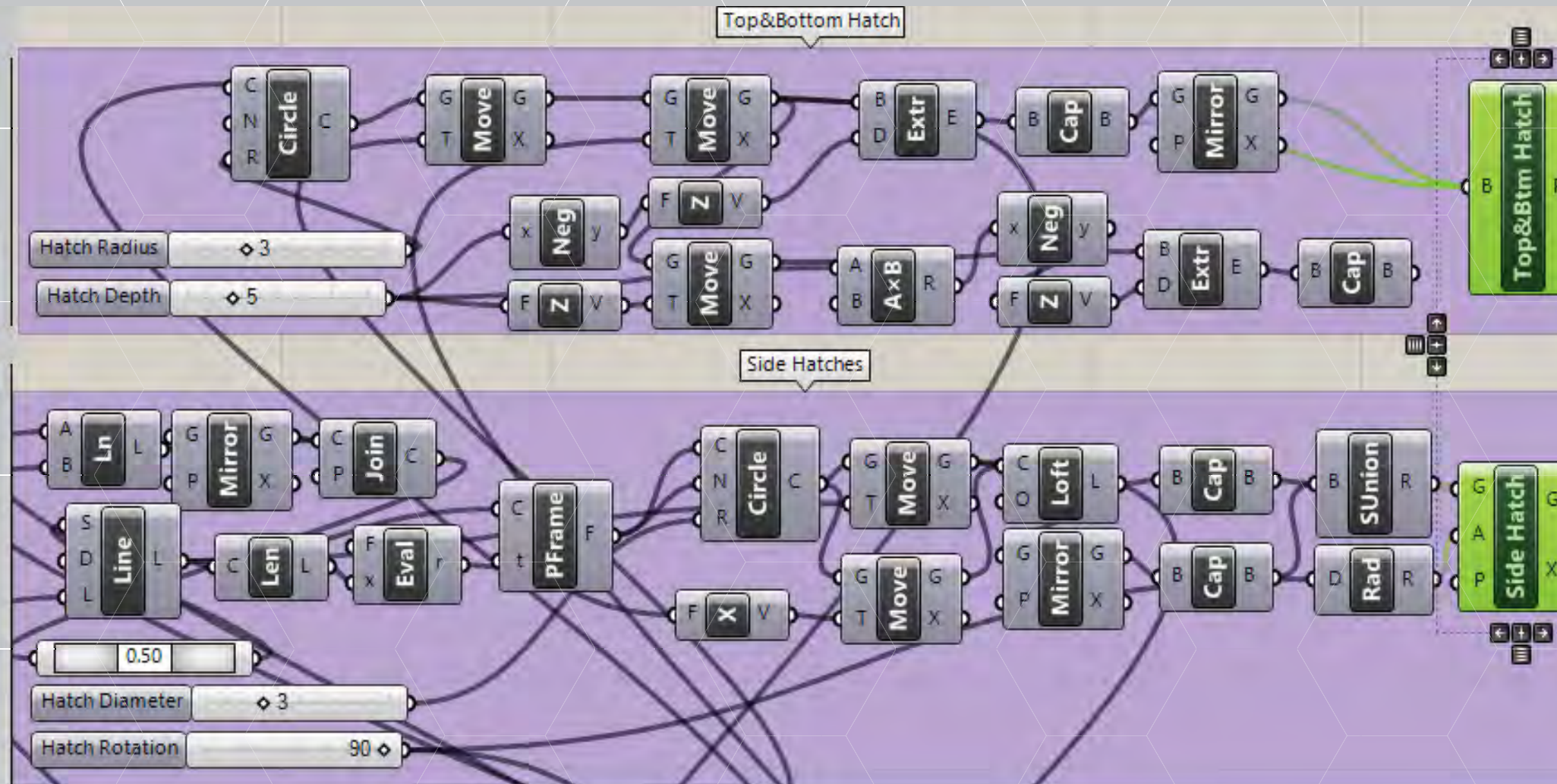

Adjust Shell thickness as needed for structure.

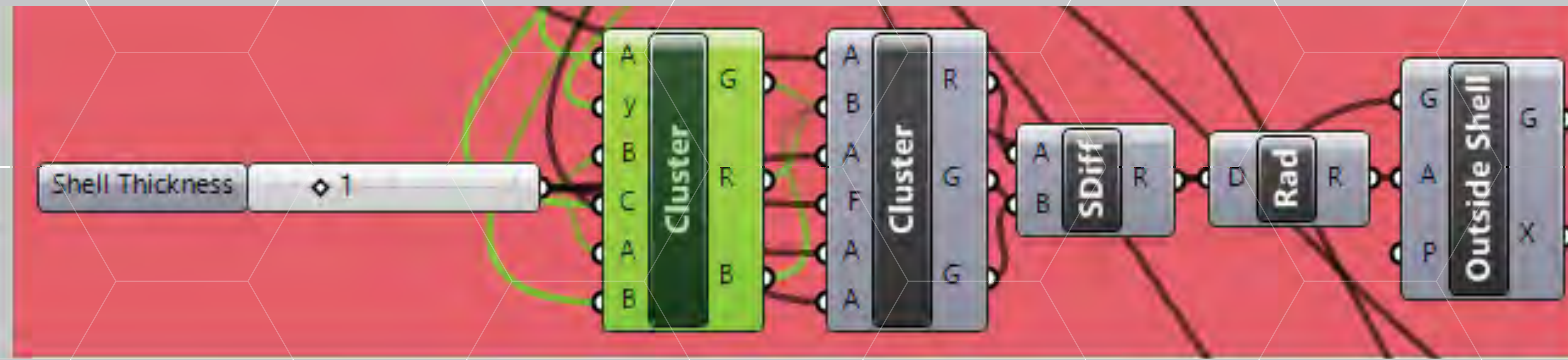

Right click and select preview to turn on and off outside shell

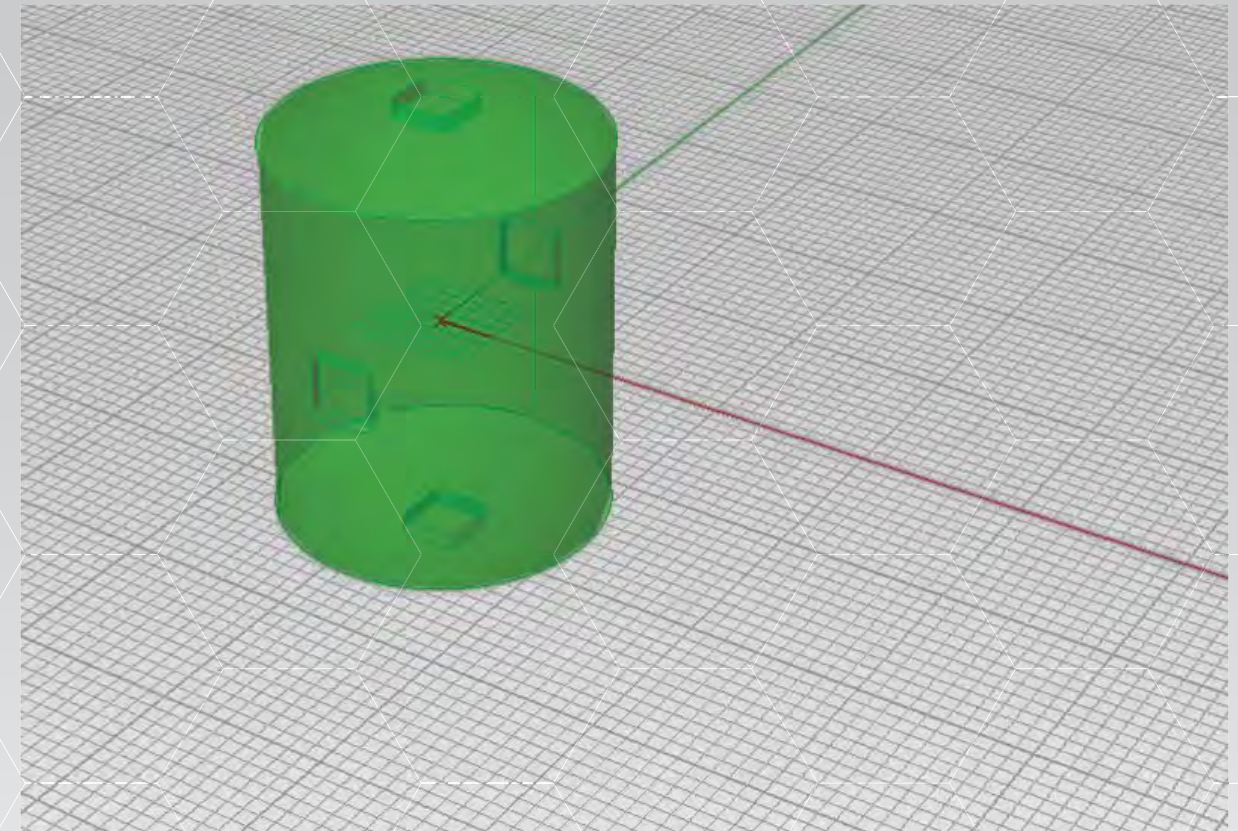
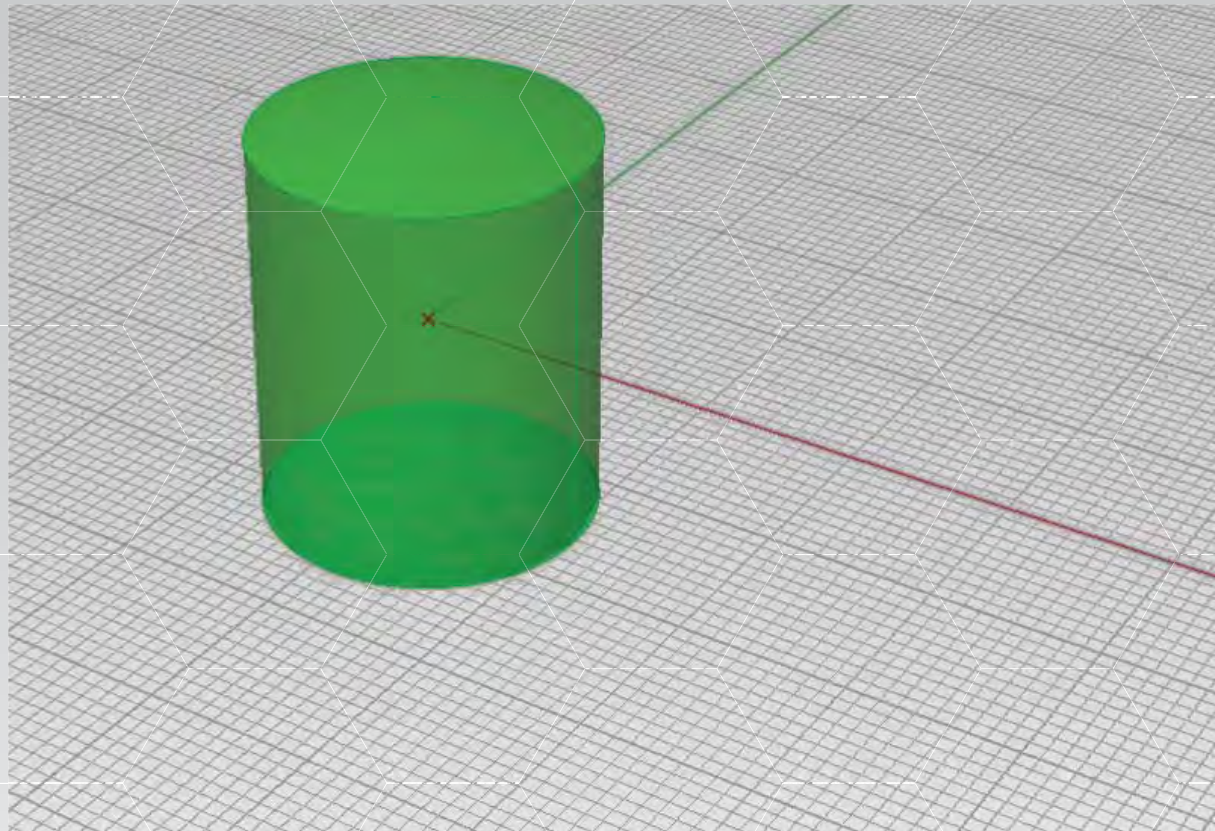

To update points right click on path and add one path to a csv file to update. or modify Xhab-PrecentagePoints.csv

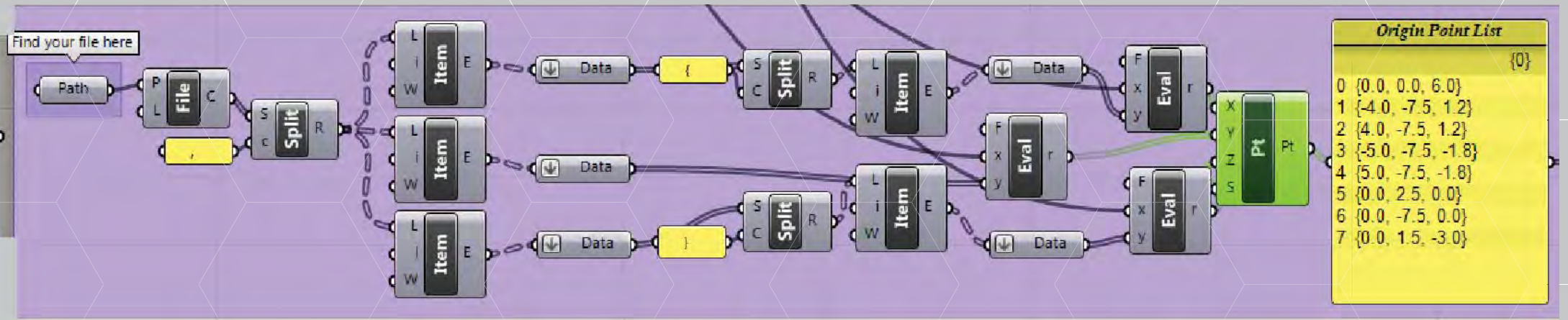

Origin Point List	
0	{0}
1	{0.0, 0.0, 6.0}
2	{-4.0, -7.5, 1.2}
3	{4.0, -7.5, 1.2}
4	{-5.0, -7.5, -1.8}
5	{5.0, -7.5, -1.8}
6	{0.0, 2.5, 0.0}
7	{0.0, -7.5, 0.0}
8	{0.0, 1.5, -3.0}



	A	B	C
1	{0	0	50}
2	{-40	-75	10}
3	{40	-75	10}
4	{-50	-75	-15}
5	{50	-75	-15}
6	{0	25	0}
7	{0	-75	0}
8	{0	15	-25}
9			

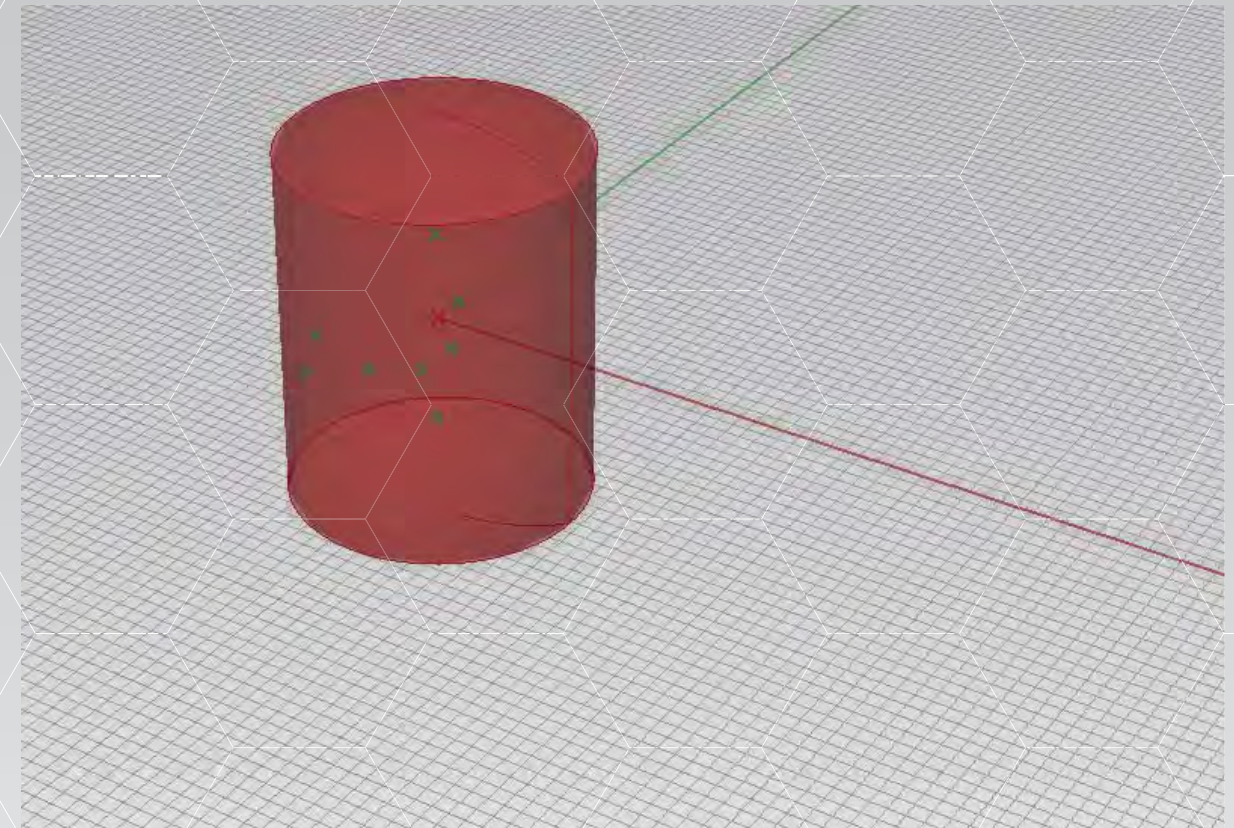

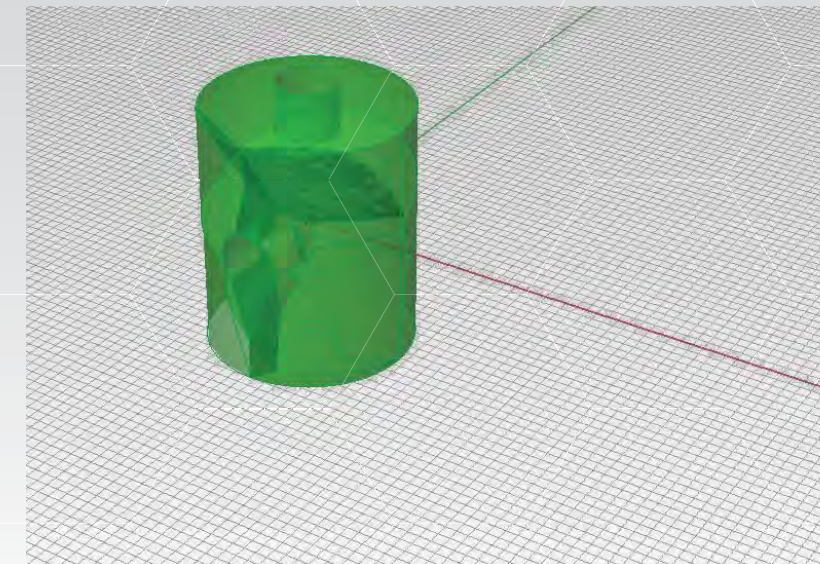
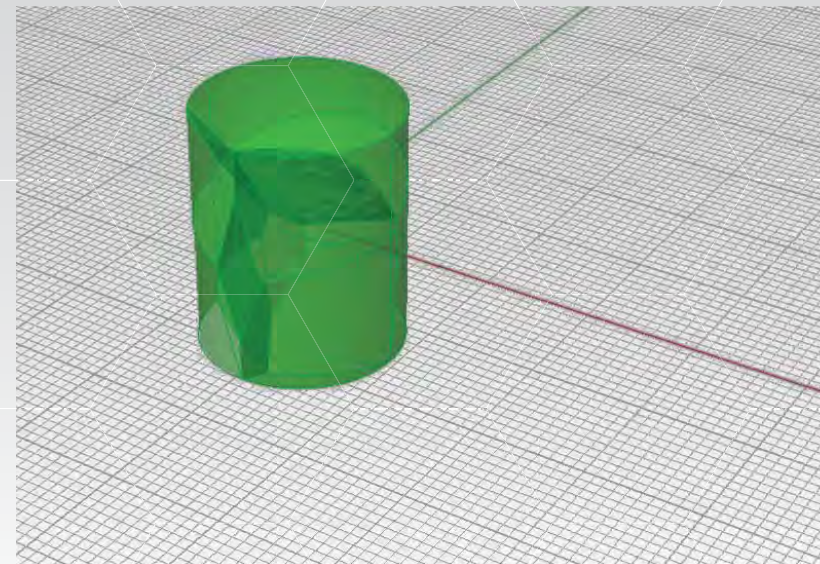
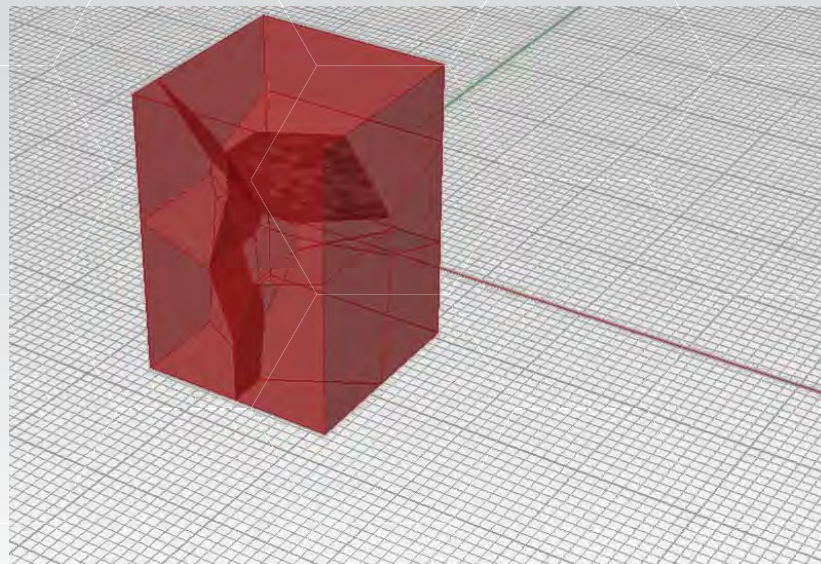
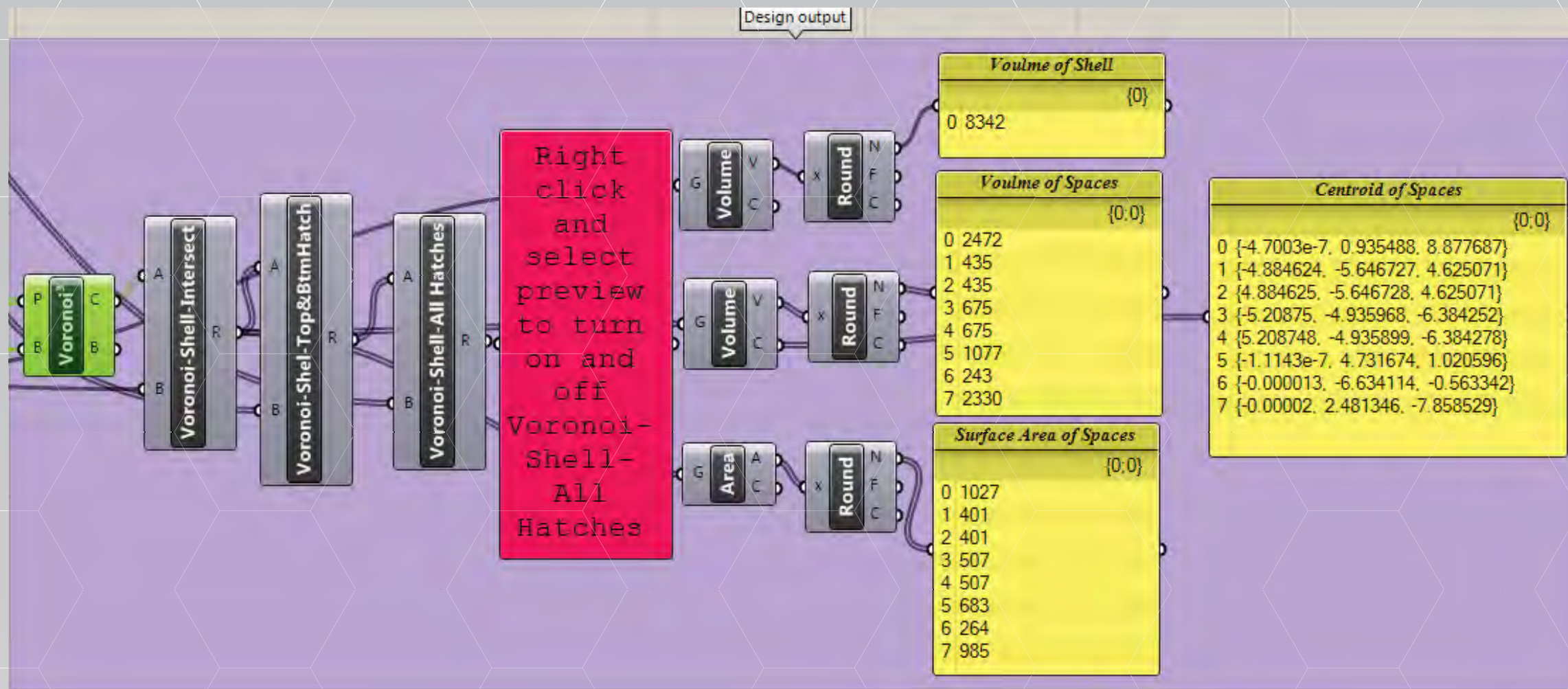

WITH ALL THE VARIABLES MODIFIED TO THE REQUIREMENTS TIME TO GENERATE SOLID 3D FORMS TO BUILD ON.

1. SELECT THE OUTSIDE SHELL
A. RIGHT CLICK AND BAKE
2. SELECT THE VORONOI-SHELL-ALL HATCHES
A. RIGHT CLICK AND BAKE

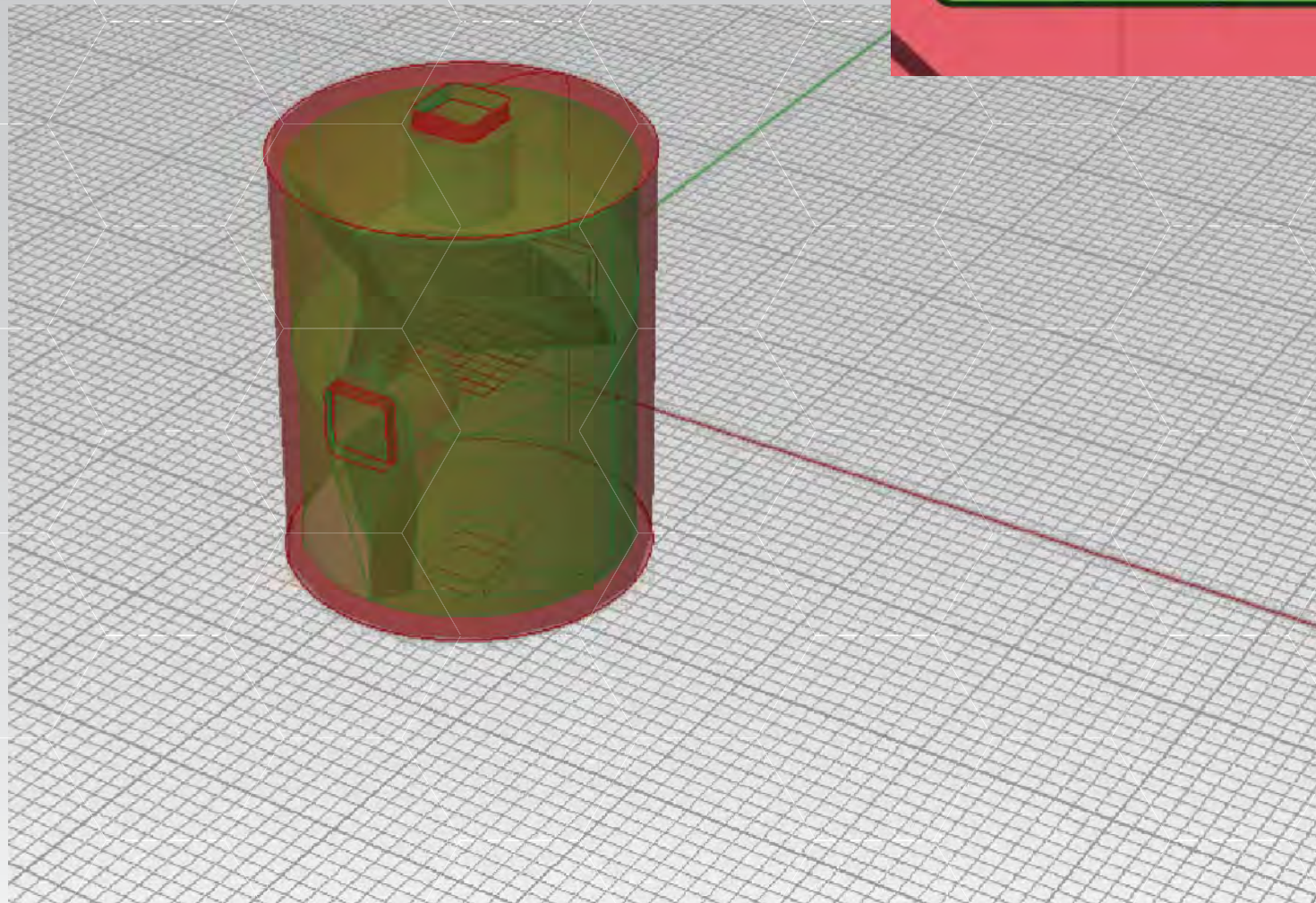
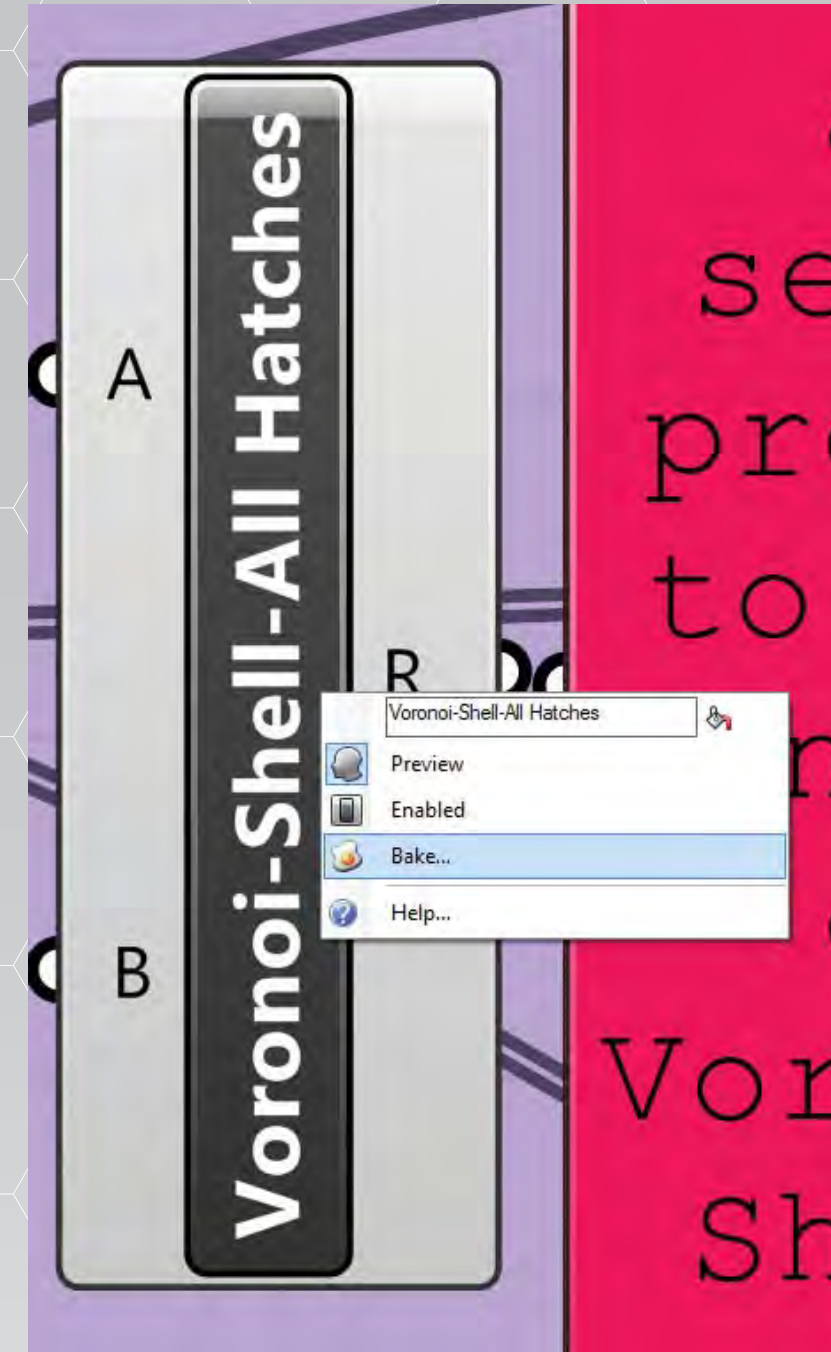
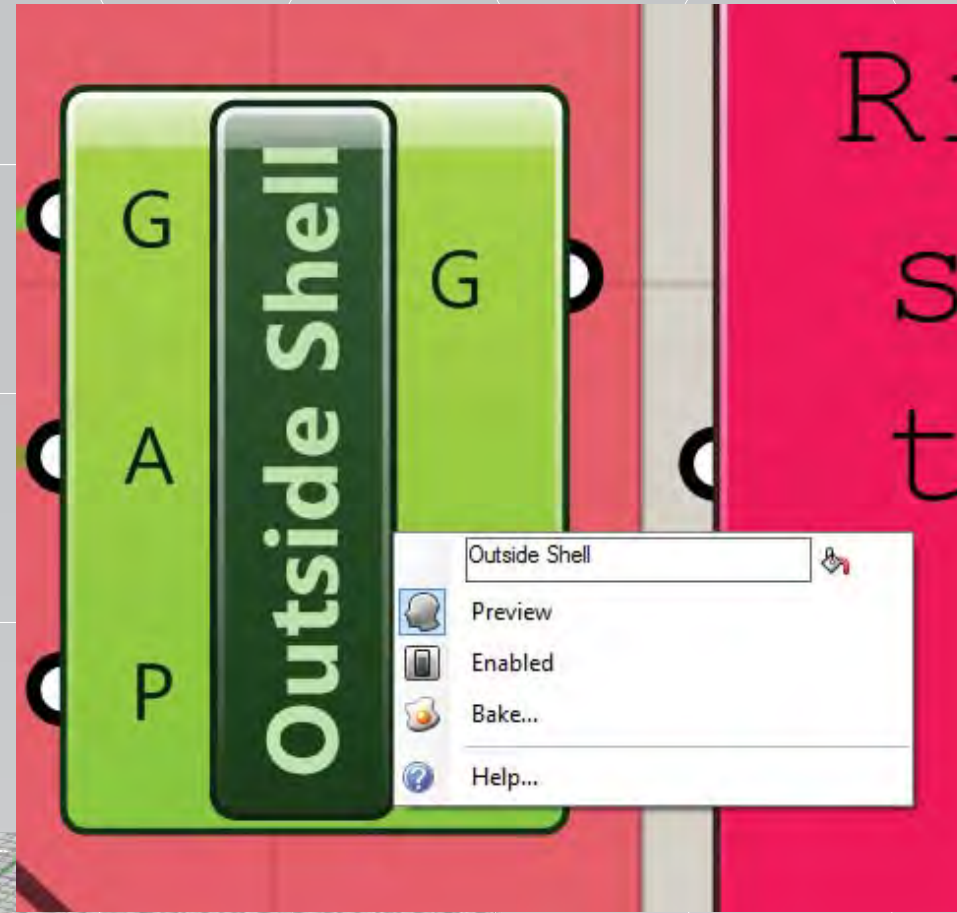

FINISHED GRASSHOPPER CONCEPT MODEL

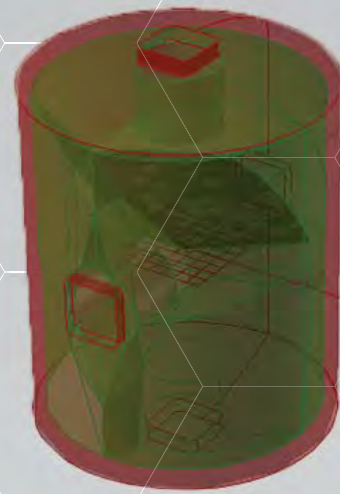

BAKED MODEL

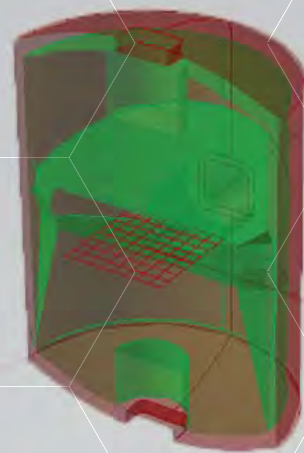

BAKED MODEL USING
CLIPPING VIEW

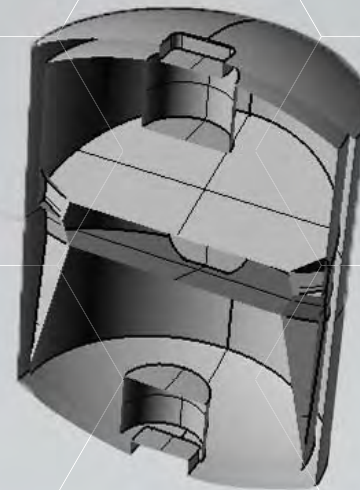

BAKED MODEL USING
CLIPPING VIEW

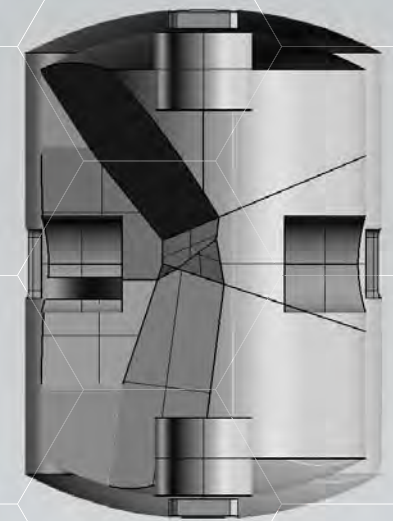

PROGRAM



SOLID/VOID

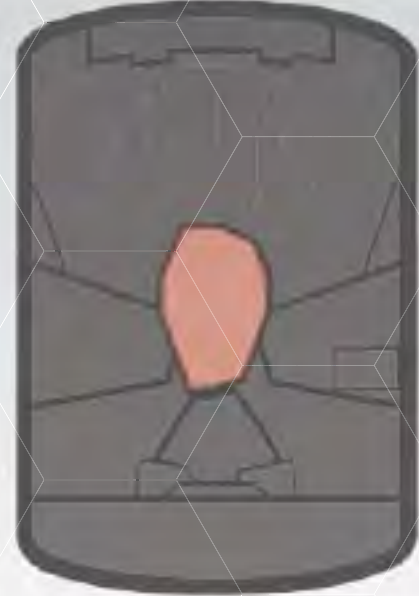
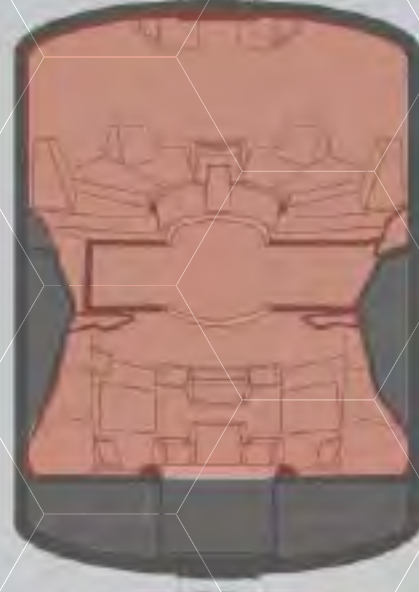

CIRCULATION

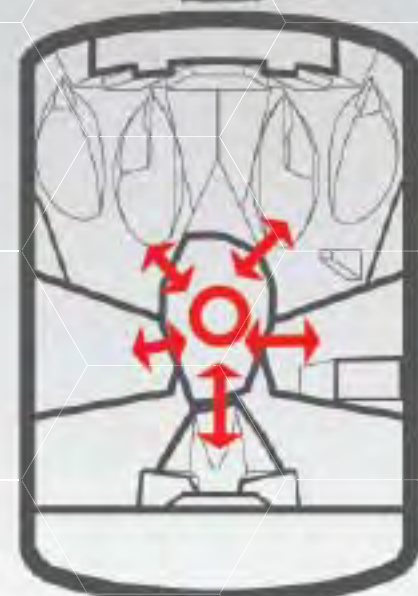
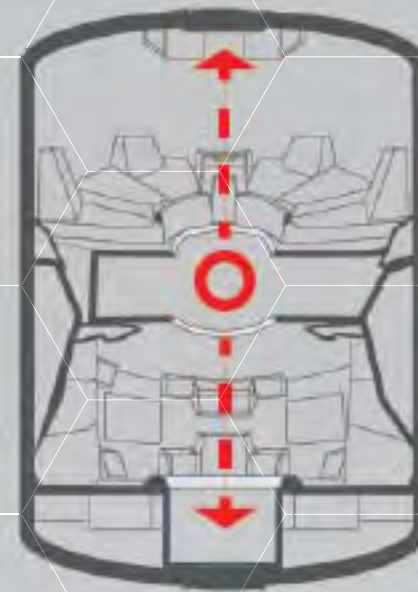

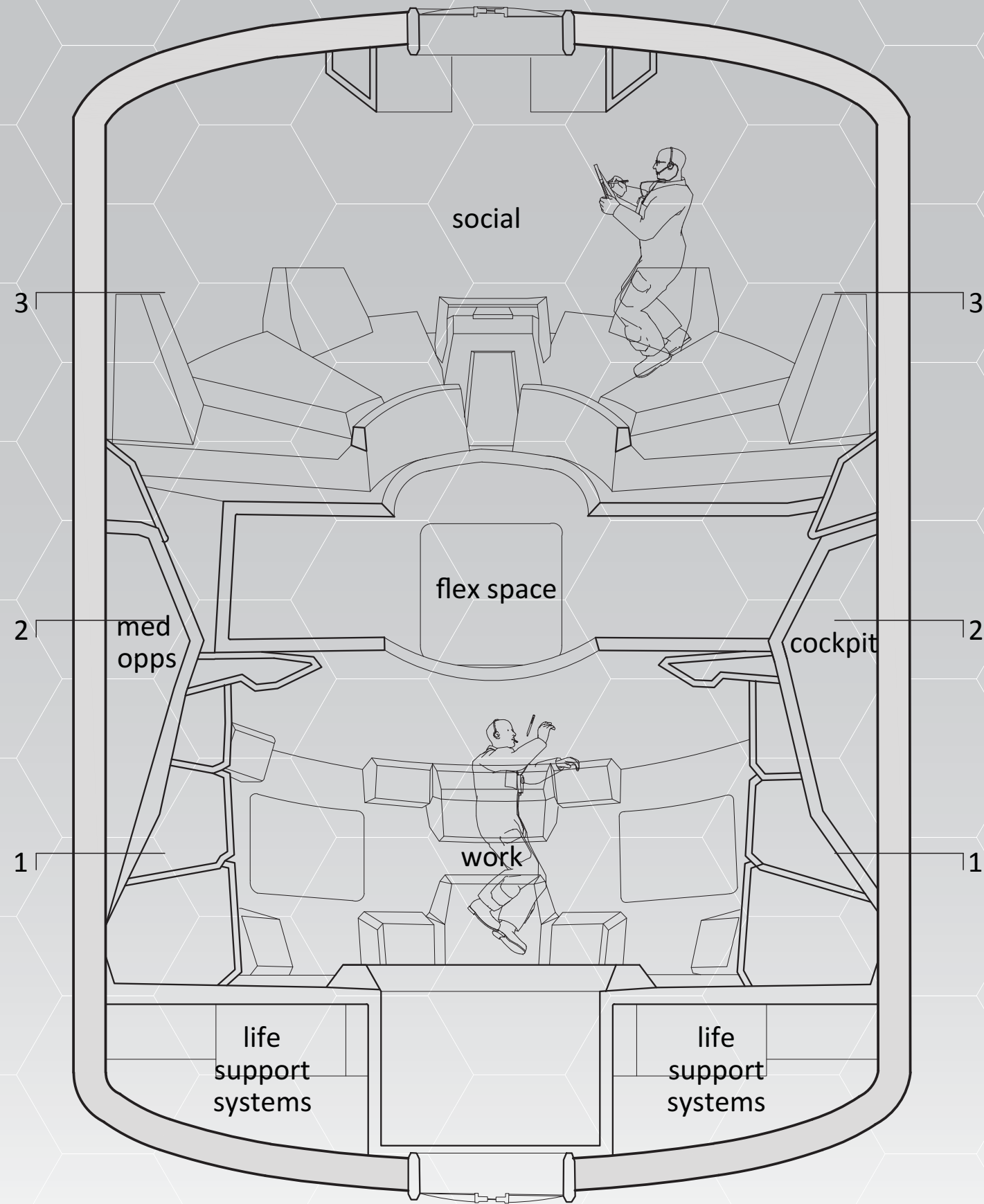

section - a-a

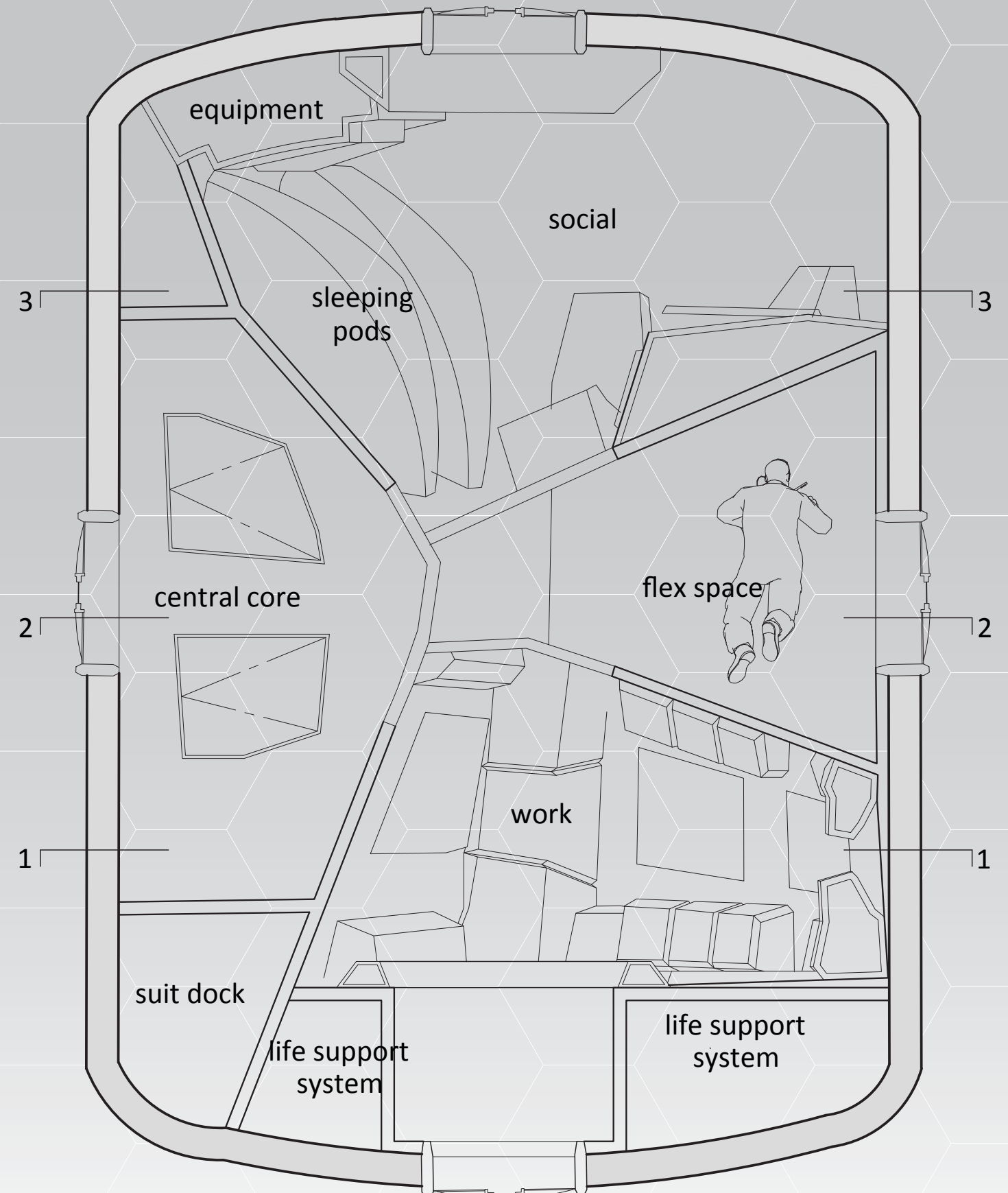

section - b-b

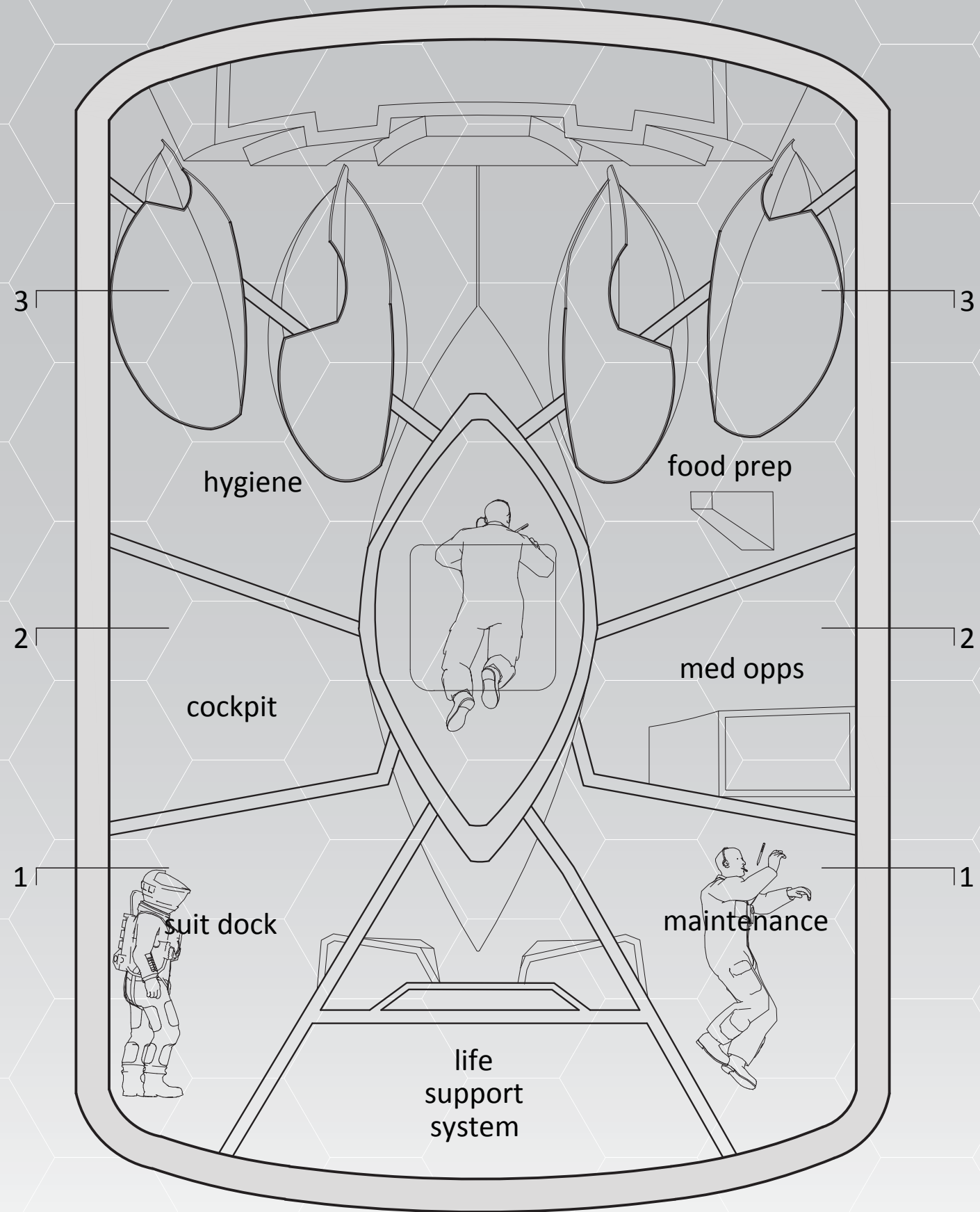

section - c-c

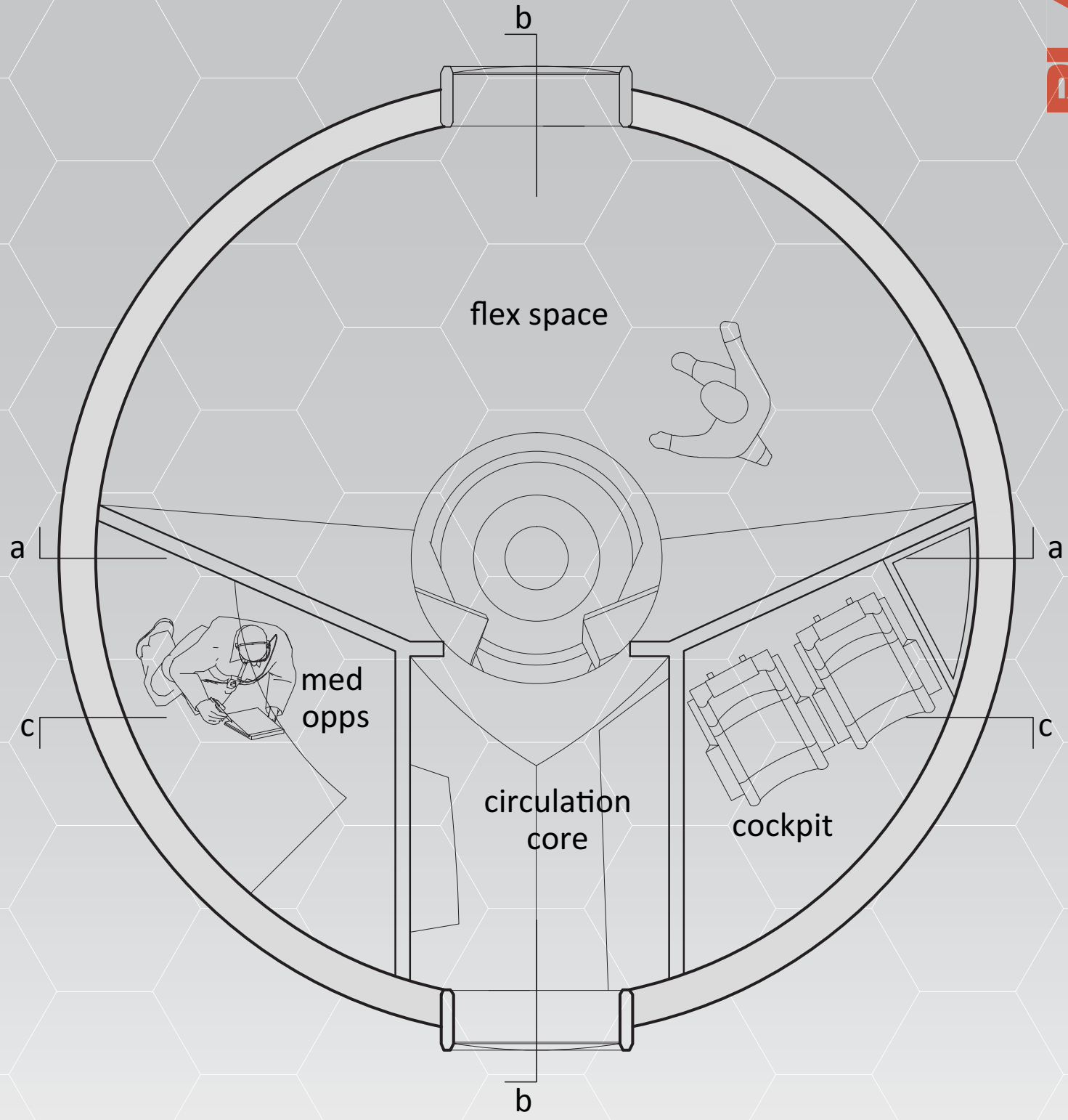
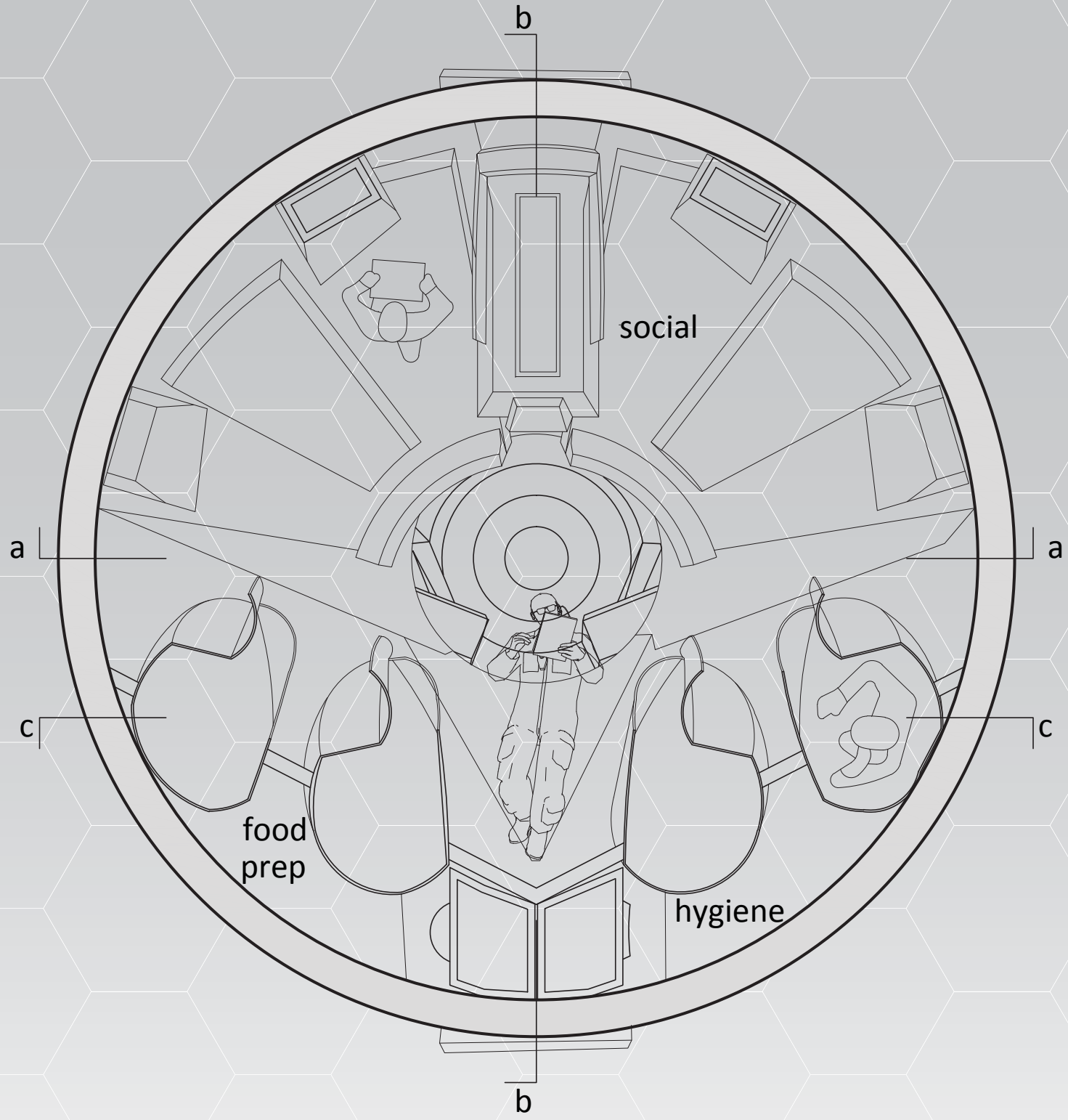

plan - 1-1

plan - 2-2

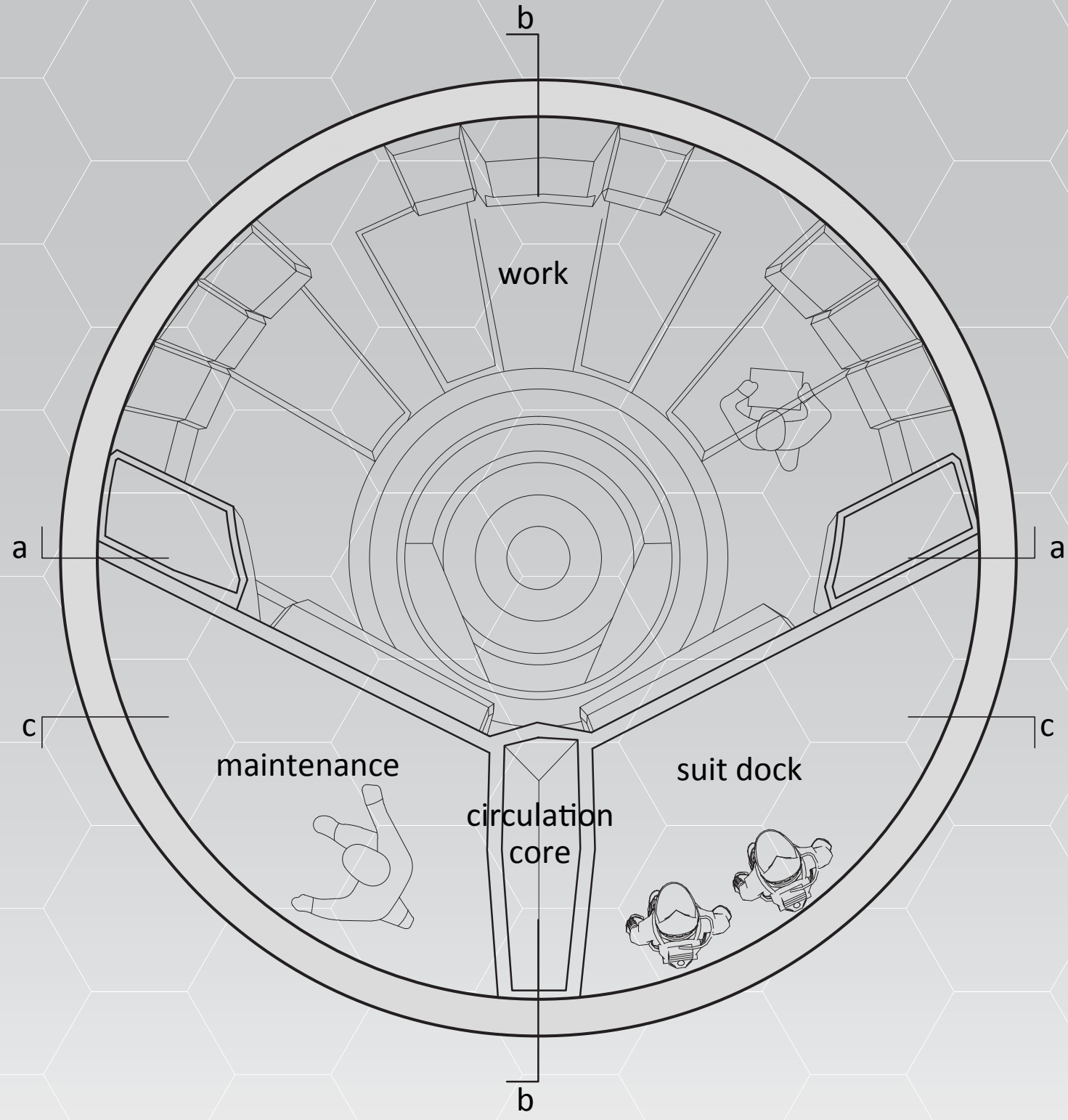

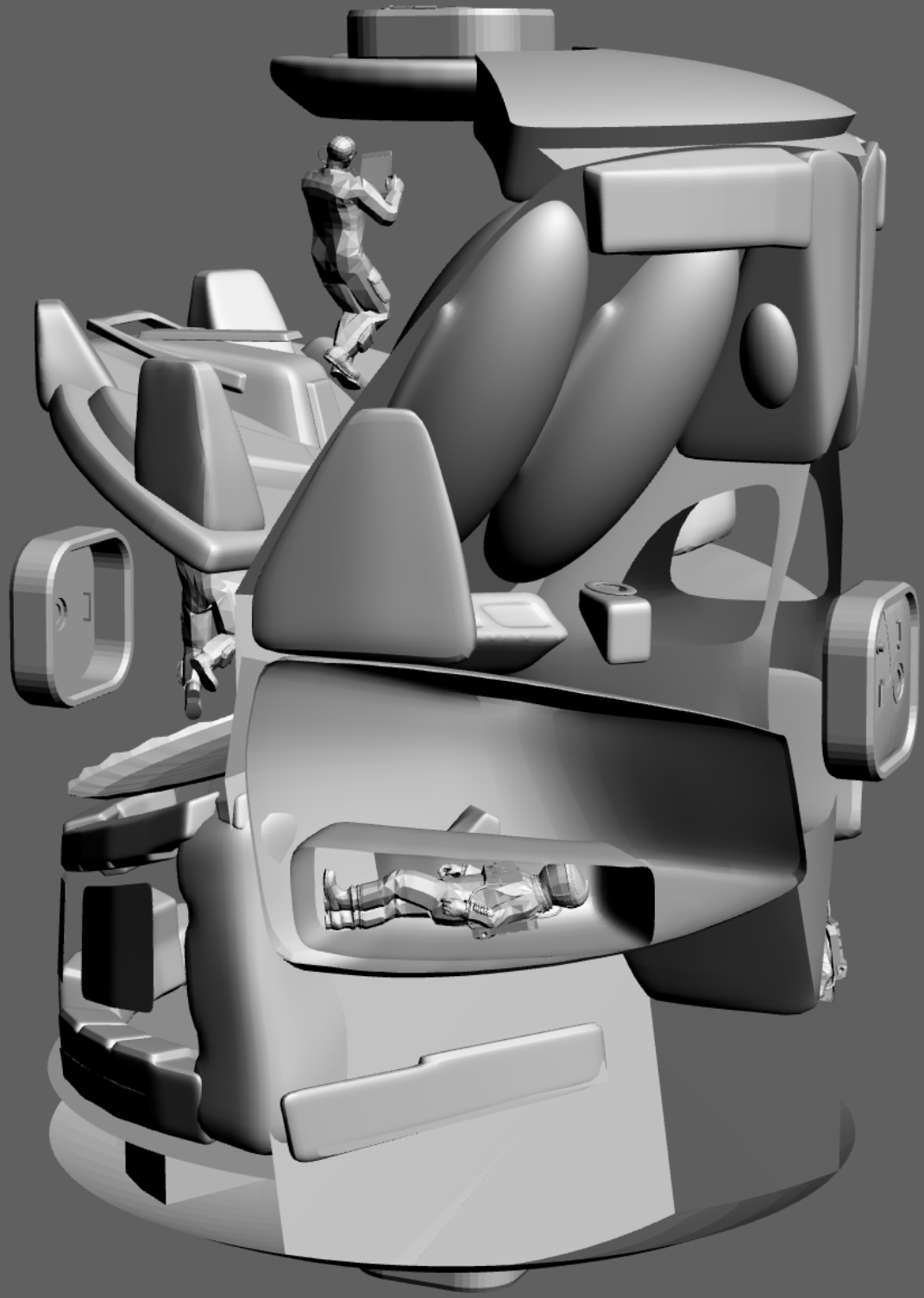

DIGITAL MODEL

SLEEPING PODS

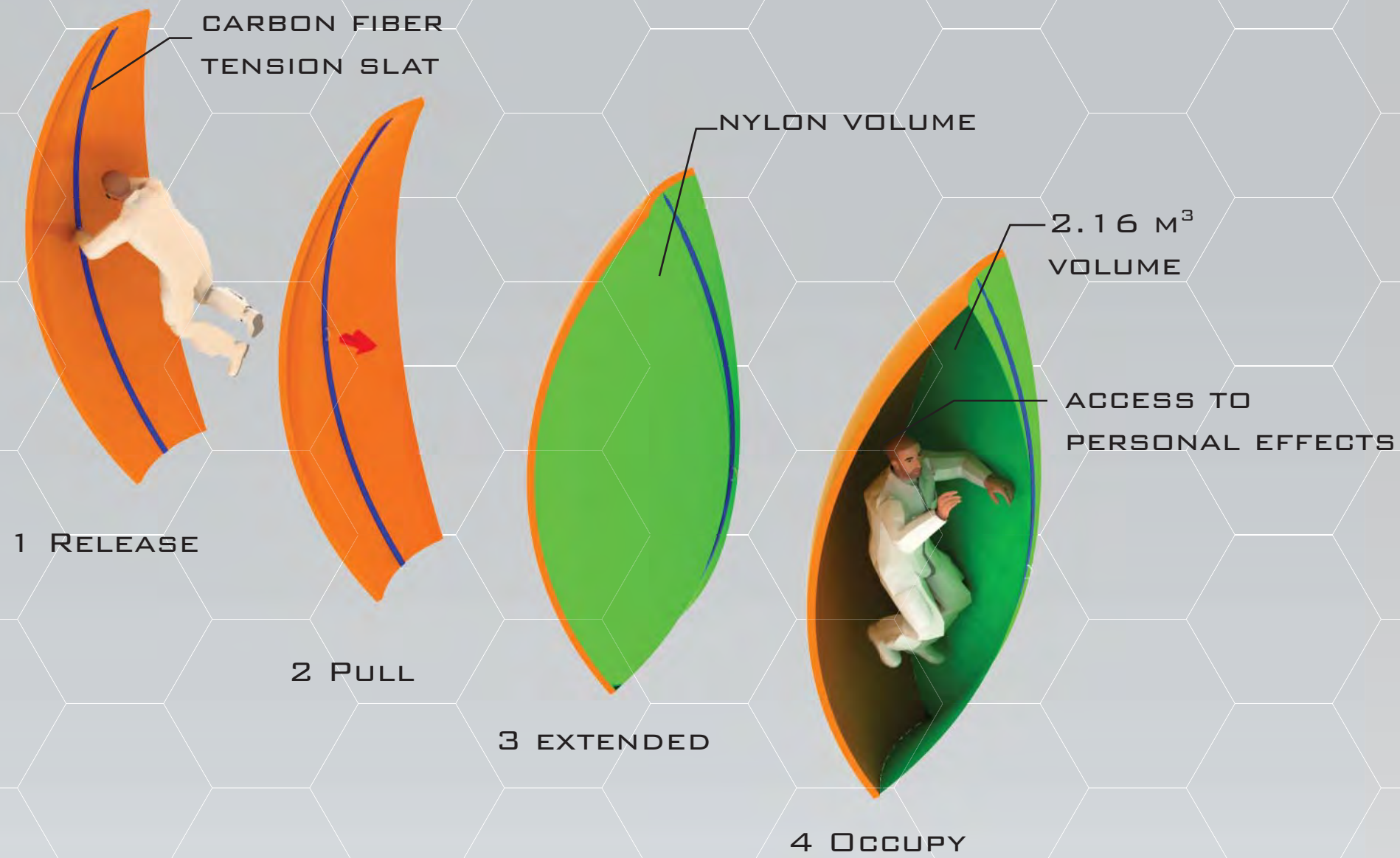

SAFE HAVEN

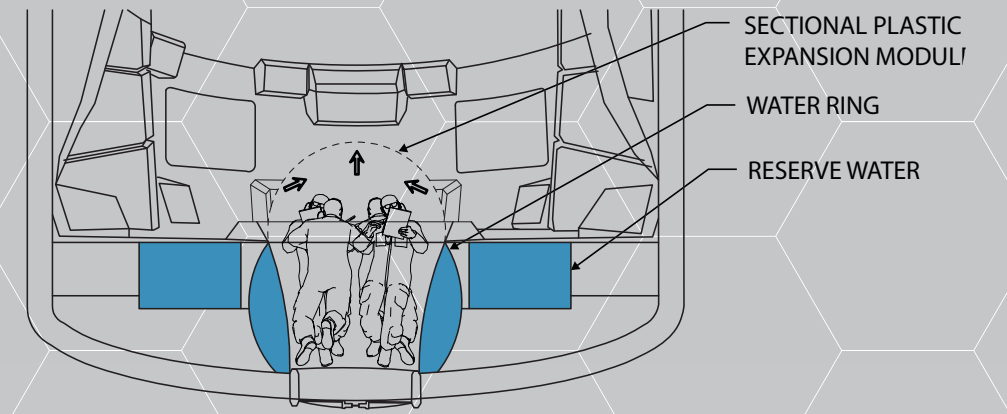

1 - Crew enters and closes expandable volume

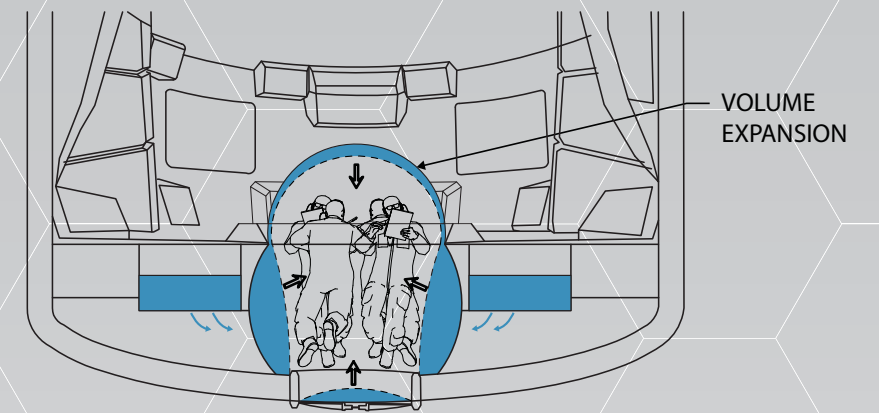

2 - Crew releases reserve water into volume

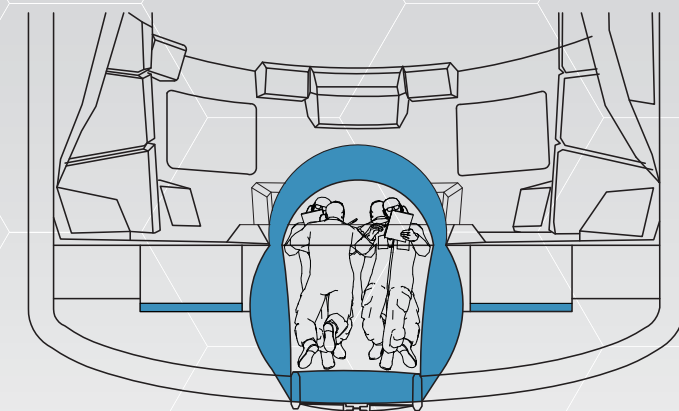

3 - Crew protected by 4 m³ water

STRUCTURE & MATERIALS

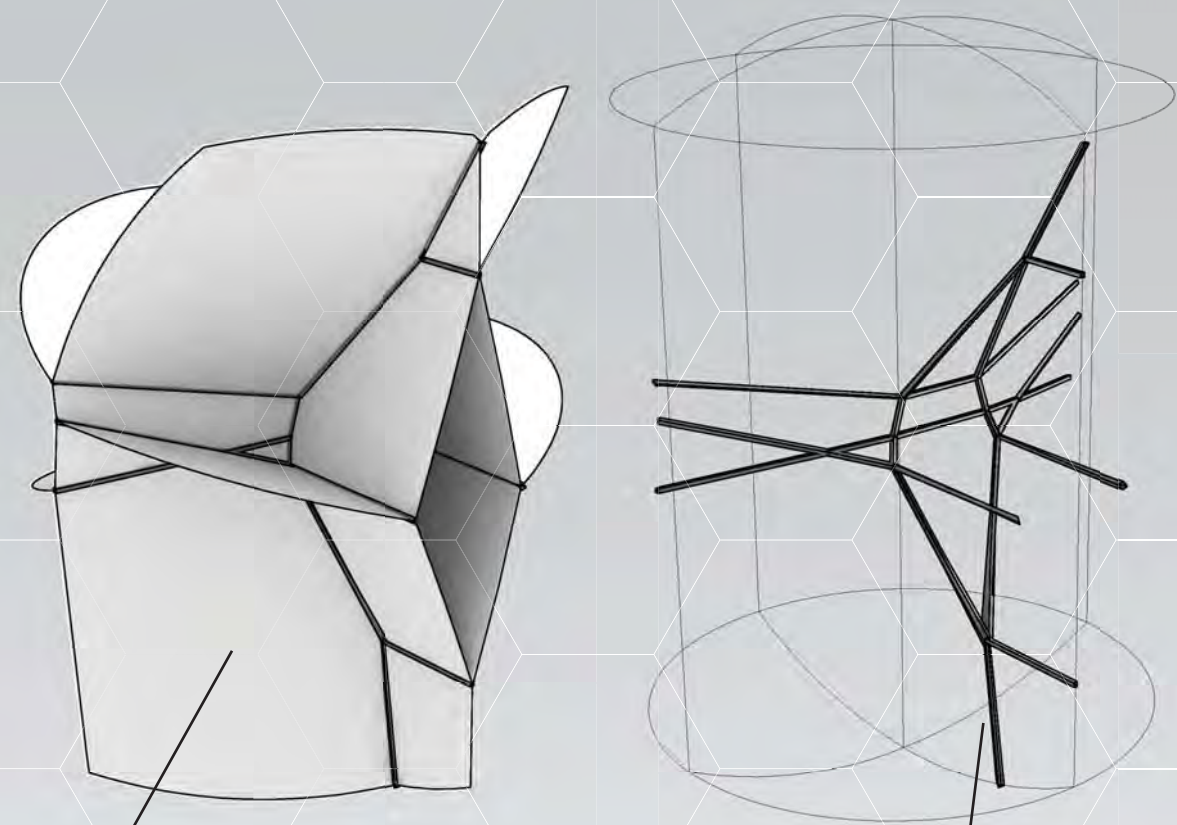

CARBON-FIBER SANDWICH
PANELS
CARBON-FIBER FRAME

SYSTEMS



WATER AND ATMOSPHERE MANAGEMENT
Duct system carries water supply, oxygen and
waste stored in the bottom portion of the habitat



ELECTRICAL SYSTEMS
Duct system also carries electricity and
mechanical throughout the habitat

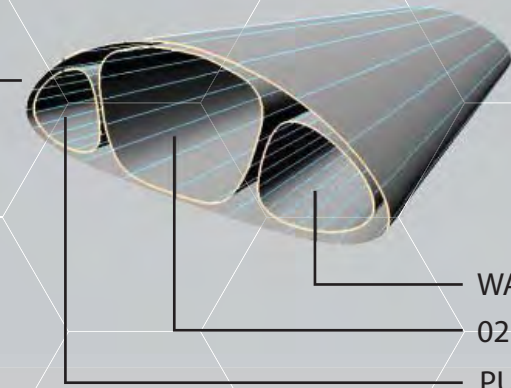

WASTE WATER FLOW
O2 ATMOSPHERE DUCT
PURIFIED WATER SUPPLY

HABITAT DUCT SYSTEM

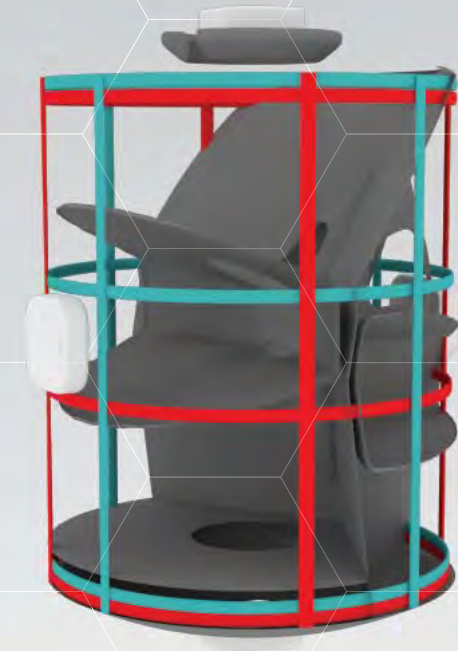

COMBINATION OF SYSTEMS



- 
Crew Quarters, Social Space & Recreation
 Four Sleeping Pods
 Personal Workspaces
- 
Hygiene Module
 Light Hygiene/Personal Hygiene
 Dressing/undressing
- 
Galley
 Food Storage
 Preparation
 Clean up
- 
Wardroom Meeting Area & Flex Space
 Eating & Meeting Table
 Lab/Social Flexible Space
- 
Cockpit
 Flight Navigation Controls
 EVA Controls
- 
Suitlock / Suitports
 EVA Suit Storage
 Airlock
 Particulate Control
- 
Medical Operations Workstation
 Crew Diagnostics
 Prognostics
- 
General Operations Workstation
 Mission Operations
 Equipment Maintenance/Repair
- 
Laboratory Work Space
 Physical Science
 Payload Science
 Workstations
- 
Water Supply & Waste Management Systems
 Environmental Control
 Life Support
 Communications & Telemetry
 Navigation & Attitude Determination Systems



Crew Quarters, Social Space & Recreation

Volume: **2,419 cu.ft.**

Contains:

- 4 Sleeping Pods**
- 4 Personal Work Spaces & Exercise Station**

The largest interior volume encloses three functions: crew quarters, social, and recreation spaces.

Crew sleeping pods opening on the main space are arranged along the interior bulkhead separating it from hygiene and the galley.

Pods expand to provide individual laptop work space and dressing/undressing areas. Pods stow allowing additional space for crew exercise equipment including resistive and aerobic workouts.

The adjacent flex space provides additional expansion space if needed.



Wardroom Meeting Area & Flex Space

Volume: **1,042 cu.ft.**

Contains:

- Stowable Meeting Table**

The third largest volume is located between the Laboratory and REcreation spaces and houses the deployable wardroom/meeting table.

Interior panels may be dynamically repositioned to join the flex wardroom with either of the adjoining spaces according to crew schedule or lab experiment needs.



Laboratory Work Space

Volume: **1,595 cu.ft.**

Contains:

- Physical Science Workstation**
- Payload Science Workstation**

Located adjacent to the Flex Space, the laboratory work space accommodates both mission and payload science experiment equipment racks. Circulation is vertically along the vessel core.



Galley

Volume: **414 cu.ft.**

Contains:

- Logistics Storage,**
- Meal Preparation**

The galley supports functions of food storage and preparation as well as clean up activities.



Hygiene Module

Volume: **414 cu.ft.**

Contains:

- Sink**
- Vacuum Toilet**
- Shower**

The hygiene module houses the Personal Hygiene Station which provides private hygiene, full body cleansing and dressing/undressing functions. Stowage of hygiene supplies is also contained within this unit.



Water Supply & Waste management System

Volume: **684 cu.ft.**

Contains:
**Water for 60 Days
Food & Drink
Cleaning Supplies**

Water supplies and waste management systems are housed in a compartment at the lowest deck to minimize launch loads imposed by high mass equipment. Waste management system treats water for reuse.

This volume also incloses Communications and Telemetry (C&T), Navigation & Attitude Determination, and Environmental Control & Life Support Systems.

Cocking port access is through the center.



Medical Operations Workstation

Volume: **292cu.ft.**

Contains:
**Crew Autonomy Equipment
Medical Supply Storage**

Crew diagnostics/prognostics functions take place in this unit supporting the medical needs of an autonomous crew on long duration missions.



General Maintenance Workstation

Volume: **292 cu.ft.**



Contains:
**Equipment Maintenance/Repair
Supplies/Parts**

Maintenance and repair of electronic, mechanical and EVA suits takes place within this workstation as well as spar parts storage, scavenging and recycling.



Cockpit

Volume: **357 cu.ft.**

Contains:
**Flight Controls,
Tele-robotics Workstation,
Intra-vehicular Activity Workstation**

Vertically oriented along the direction of travel, the cockpit supports mission critical functions of flight control and navigation.

Command and Data Handling (C&DH), Passive Automated Rendezvous & Docking, Integrated Systems Health Management (ISHM) and Crew Autonomy (diagnostics/prognostics) are also housed in this compartment.



Suitlock / Suitport

Volume: **357 cu.ft.**

Contains:
**Crew Suitports
EVA Suitlock
Particulate Contamination Control**

The airlock is located near the center of the capsule between the interior circulation aisle and the exterior hatch. It supports mission and contingency EVA activities while maintaining atmospheric pressure integrity of the vessel.

Faux Bim.xlsx - Microsoft Excel

File Home Insert Page Layout Formulas Data Review View

From Access From Web From Text From Other Sources Existing Connections Refresh All Edit Links Connections Sort & Filter Filter Clear Reapply Advanced Text to Columns Remove Duplicates Data Validation Consolidate What-If Analysis Group Ungroup Subtotal Show Detail Hide Detail Outline

A2

	A	B	C	D	E	F	G	H	I	J	K	L	M	N	O	P	Q	R	S	T	U	V	W	X	
1	Area of Spaces				Centroid of Space				Volumn of Space																
2	1027				[-4.7003e-7	0.935488	8.877687]				2472														
3	401				[-4.884624	-5.646727	4.625071]				435														
4	401				[4.884625	-5.646728	4.625071]				435														
5	507				[-5.20875	-4.935968	-6.384252]				675														
6	507				[5.208748	-4.935899	-6.384278]				675														
7	683				[-1.1143e-7	4.731674	1.020596]				1077														
8	264				[-0.000013	-6.634114	-0.563342]				243														
9	985				[-0.00002	2.481346	-7.858529]				2330														
10																									
11																									
12																									
13	Point Space				Points of Origin				Percentage of Point																
14	{0.0	1.5	7.2}		0	0	6		{0	0	50}														
15	{-5.0	-7.5	1.2}		-4	-7.5	1.2		{-40	-75	10}														
16	{5.0	-7.5	1.68}		4	-7.5	1.2		{40	-75	10}														
17	{-5.0	-7.5	-1.8}		-5	-7.5	-1.8		{-50	-75	-15}														
18	{5.0	-7.5	-1.8}		5	-7.5	-1.8		{50	-75	-15}														
19	{0.0	2.5	0.0}		0	2.5	0		{0	25	0}														
20	{0.0	4	-4.8}		0	-7.5	0		{0	-75	0}														
21					0	1.5	-3		{0	15	-25}														
22																									
23																									
24																									
25																									
26																									
27																									
28																									
29																									
30																									
31																									
32																									
33																									
34																									

Material Sheet Frame Config Wall Configuration Processed Output Data Original Output Data

Ready 100%

Material Properties Chart:					
Structural Materials:		Panel Core:			
	Aluminum	Carbon Fiber	Fiberglass	Honeycomb	Expanded Polystyrene
Weight:					
	170 lbs/ft ³	83 lbs/ft ³	2.5 lbs/ft ³	1 lbs/ft ³	1.5 lbs/ft ³
Cost:					

Frame Material Breakdown	
General Material:	Carbon Fiber
Weight:	83 lb/ft ³
Cost:	\$
Structural Thickness:	1 in
Percentage of Material:	15%
Percentage of Hollow Space:	85%
Total Weight:	1.038 lb/
Total Cost:	ft ³ /ft ³

Panel Material Breakdown			
Variation: 1		Variation: 2	
Panel Siding Material:	Carbon Fiber	Panel Siding Material:	Aluminum
Weight:	83 lb/ft ³	Weight:	170 lb/ft ³
Cost:	\$ /ft ³	Cost:	\$ /ft ³
Thickness of Material:	0.125 in	Thickness of Material:	0.125 in
Panel Core Material:	Honeycomb	Panel Core Material:	Fiberglass
Weight:	1 lb/ft ³	Weight:	2.5 lb/ft ³
Cost:	\$ /ft ³	Cost:	\$ /ft ³
Thickness of Material:	0.5 in	Thickness of Material:	0.5 in
Total Thickness:	0.75 in	Total Thickness:	0.75 in
Total Weight:	1.771 lb/ft ²	Total Weight:	3.646 lb/ft ²
Total Cost:	\$ /ft ²	Total Cost:	\$ /ft ²

Through Researched Material Properties, Excel can convert the grasshopper Output into usable Data for Mass Consideration, Cost Estimates, Volumn of Spaces. By Creating variations on Panels allow for a optimized solution that is both cost effective and lightweight without losing desired properties.



Social Space	
Total Surface Area:	821.6 ft ²
Percentage of Wall:	
Frame:	10%
Panels:	90%
Total Weight of Walls:	1394.67
Total Cost of Walls:	lbs\$
Volumn of Wall:	53.06 ft ³
Volumn of Space:	2418.94 ft ³



Cockpit	
Total Surface Area:	223.08 ft ²
Percentage of Wall:	
Frame:	10%
Panel:	90%
Total Weight of Walls:	378.68
Total Cost of Walls:	lbs\$
Volumn of Wall:	14.41 ft ³
Volumn of Space:	356.84 ft ³

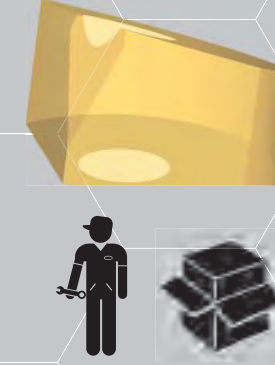

General Operations	
Total Surface Area:	182.52 ft ²
Percentage of Wall:	
Frame:	10%
Panels:	90%
Total Weight of Walls:	309.83
Total Cost of Walls:	lbs\$
Volumn of Wall:	11.79 ft ³
Volumn of Space:	291.96 ft ³



Hygiene Module	
Total Surface Area:	320.8 ft ²
Percentage of Wall:	
Frame:	10%
Panel:	90%
Total Weight of Walls:	544.56 lbs
Total Cost of Walls:	\$
Volumn of Wall:	20.72 ft ³
Volumn of Space:	414.28 ft ³

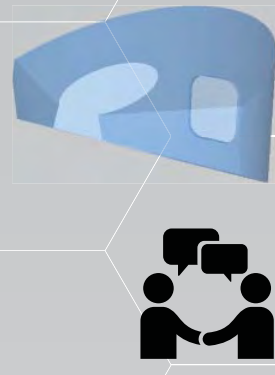

Wardroom/ Flexspace	
Total Surface Area:	546.4 ft ²
Percentage of Wall:	
Frame:	10%
Panels:	90%
Total Weight of Walls:	927.51
Total Cost of Walls:	lbs\$
Volumn of Wall:	35.29 ft ³
Volumn of Space:	1041.71 ft ³

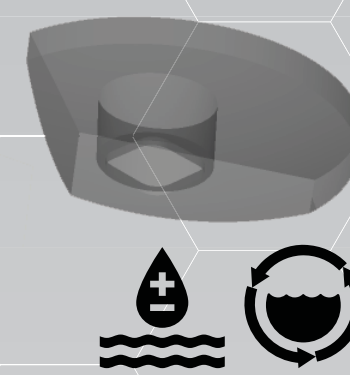

Water/Waste Management	
Total Surface Area:	236.4 ft ²
Percentage of Wall:	
Frame:	10%
Panel:	90%
Total Weight of Walls:	817.55
Total Cost of Walls:	lbs\$
Volumn of Wall:	15.27 ft ³
Volumn of Space:	683.73 ft ³



Galley	
Total Surface Area:	320.8 ft ²
Percentage of Wall:	
Frame:	10%
Panels:	90%
Total Weight of Walls:	544.56 lbs
Total Cost of Walls:	\$
Volumn of Wall:	20.72 ft ³
Volumn of Space:	414.28 ft ³

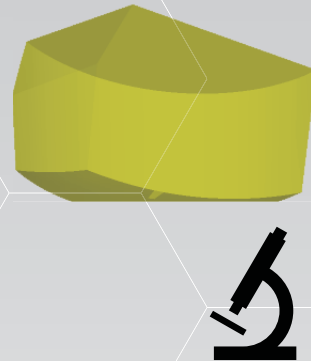

Laboratory Workspace	
Total Surface Area:	551.6 ft ²
Percentage of Wall:	
Frame:	10%
Panels:	90%
Total Weight of Walls:	936.34
Total Cost of Walls:	lbs\$
Volumn of Wall:	35.62 ft ³
Volumn of Space:	1595.38 ft ³

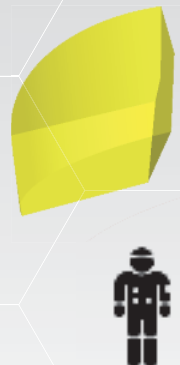

Suit Dock	
Total Surface Area:	223.08 ft ²
Percentage of Wall:	
Frame:	10%
Panel:	90%
Total Weight of Walls:	378.68 lbs
Total Cost of Walls:	\$
Volumn of Wall:	14.41 ft ³
Volumn of Space:	356.84 ft ³



Medical Operations	
Total Surface Area:	182.52 ft ²
Percentage of Wall:	
Frame:	10%
Panels:	90%
Total Weight of Walls:	309.83 lbs
Total Cost of Walls:	\$
Volumn of Wall:	11.79 ft ³
Volumn of Space:	291.96 ft ³

General Information	
Combined Weight of Material:	5922.54
Combined Cost of Material:	lbs\$
Frame Percentage:	10%
Panel Percentage:	90%
Total Volumn of Wall:	246.71 ft ³
Total Volumn of Space:	8095.29 ft ³
Total Volumn of Xhab:	8342 ft ³
Percentage of Usable Space	97.04%
Percentage of Stowage Space	7%
Percentage of Life Support Space Usage	8%
Percentage of Equipment Space Usage	12%
Percentage of Usable Open Space	69.66%



WINTER 2013

DESIGN DEVELOPMENT FROM
WINTER 2013 + FULL
SCALE PROJECT MOCK UP

4

design process

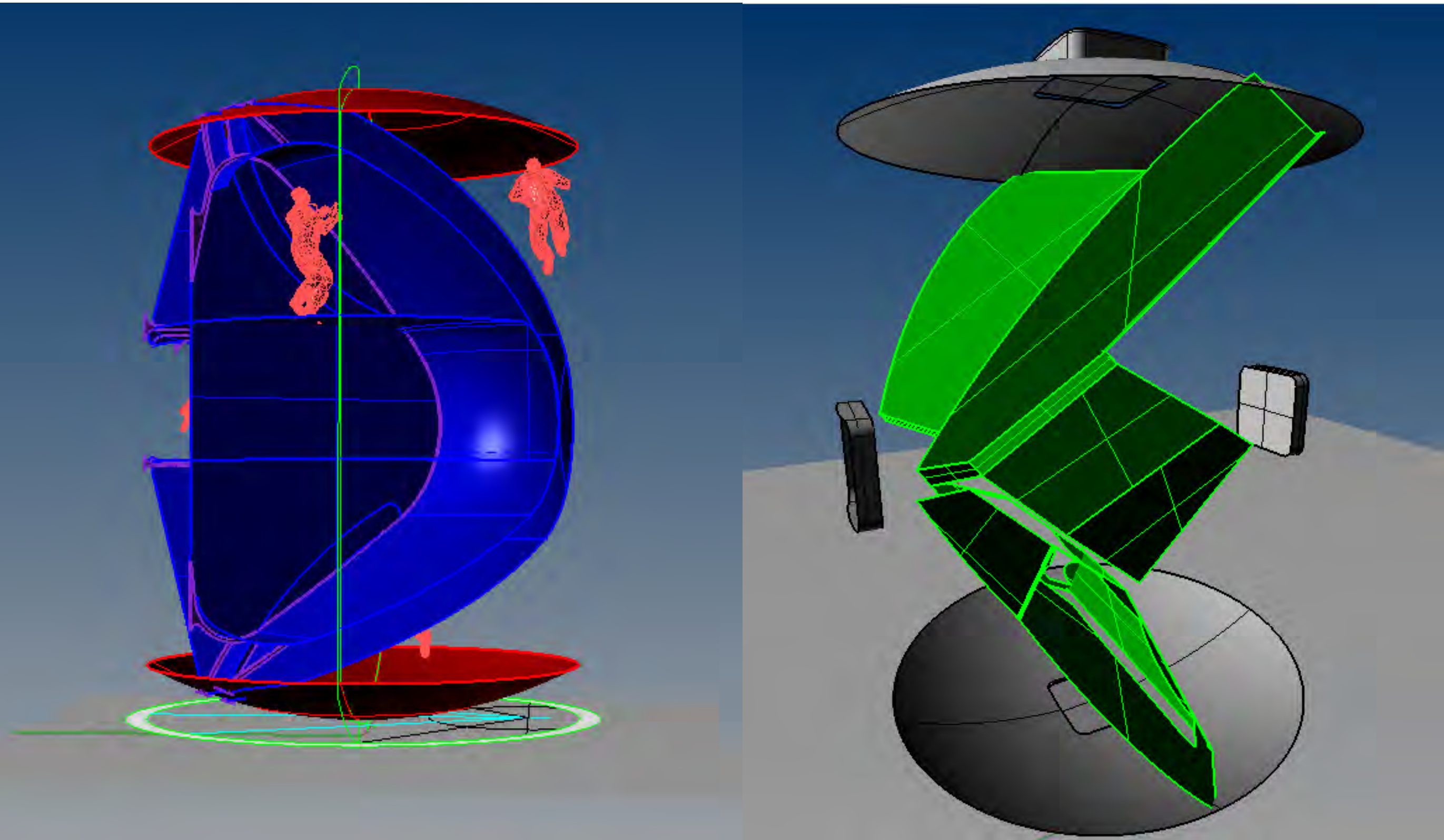

circulation

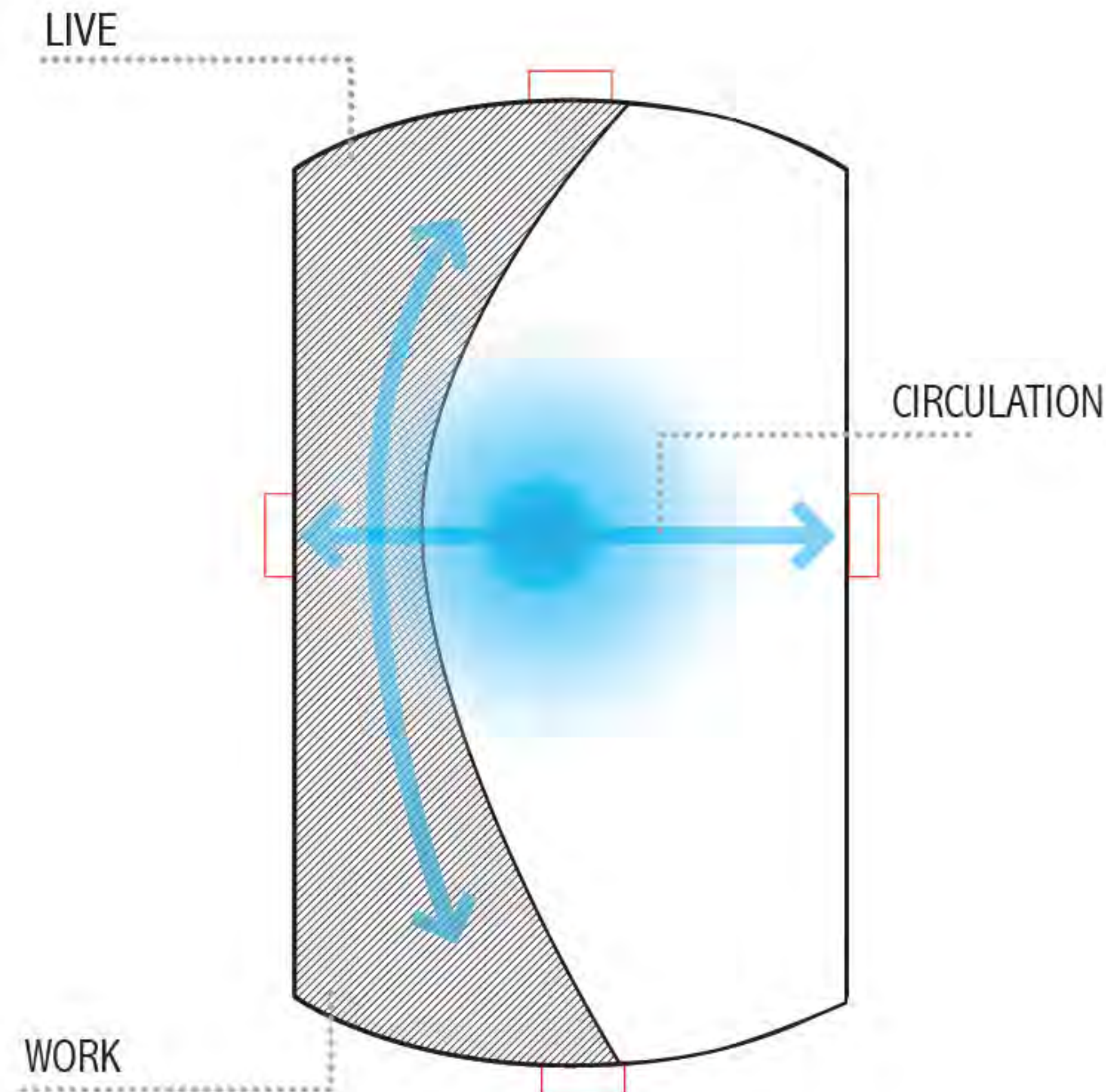

spatial division

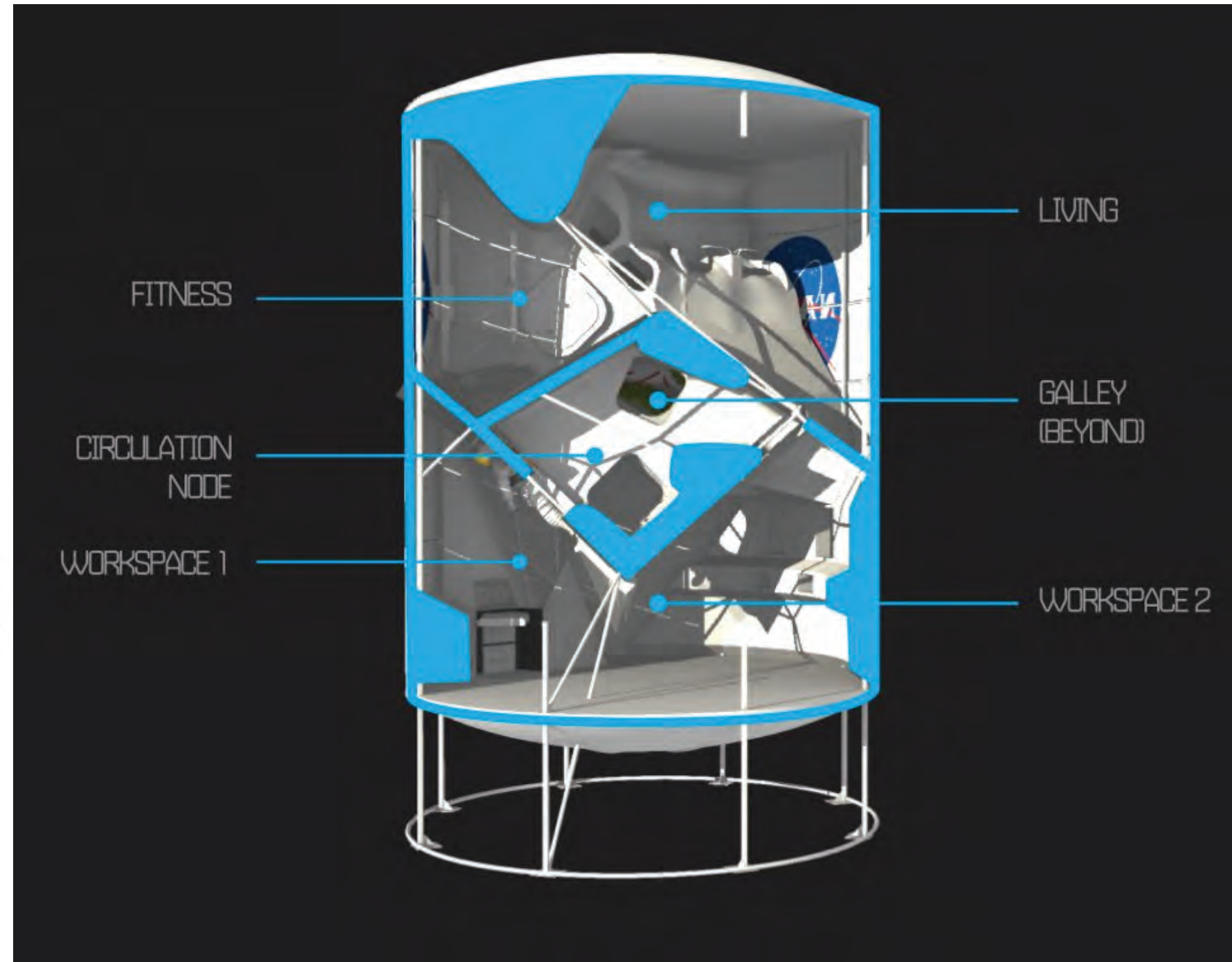
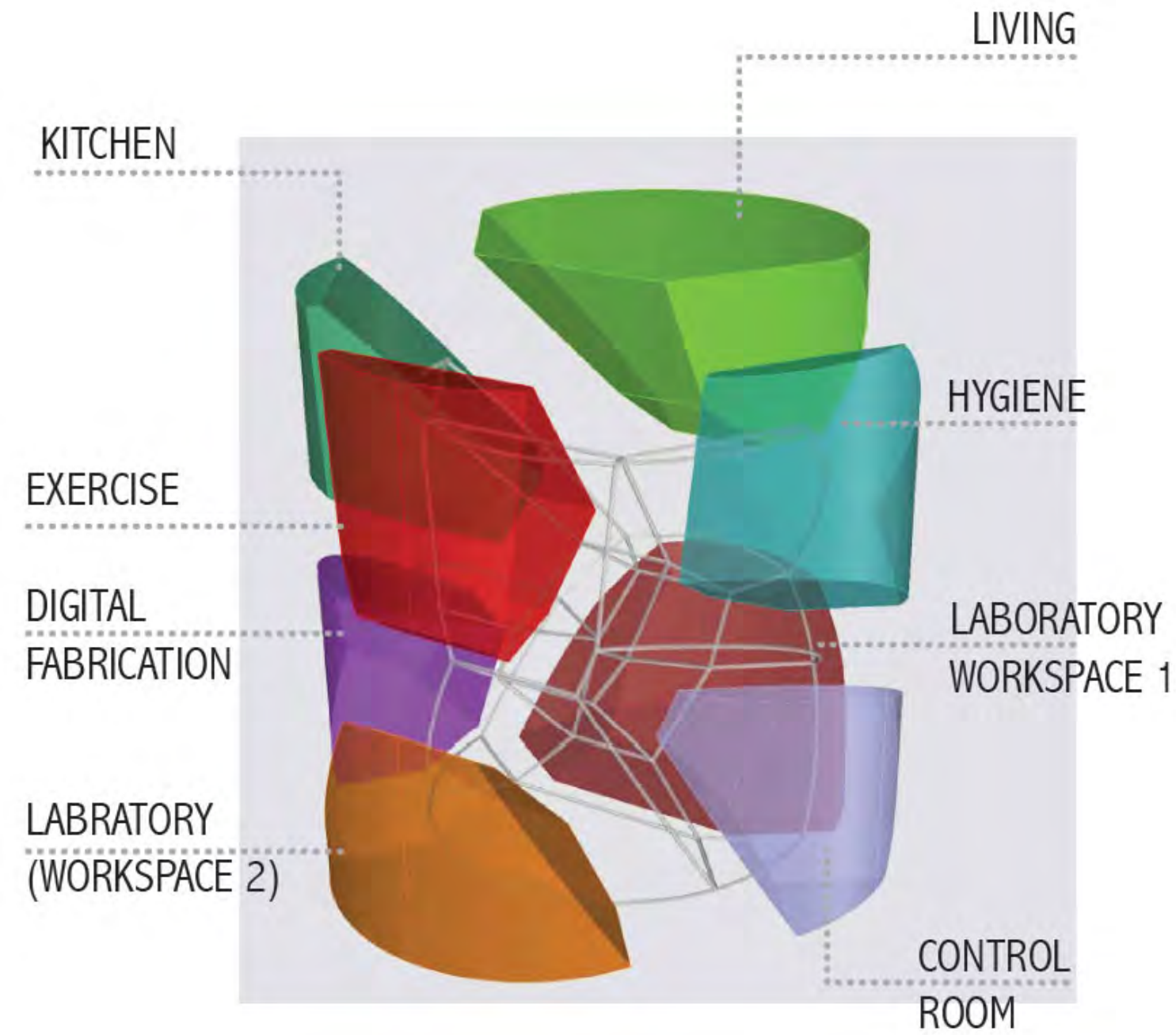

structure

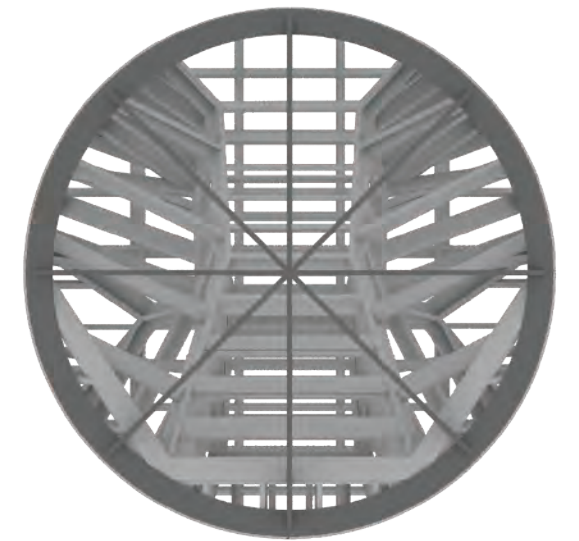
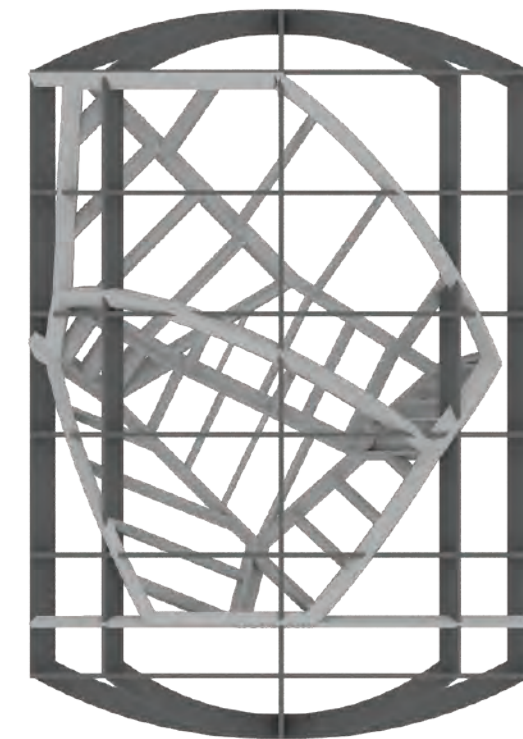
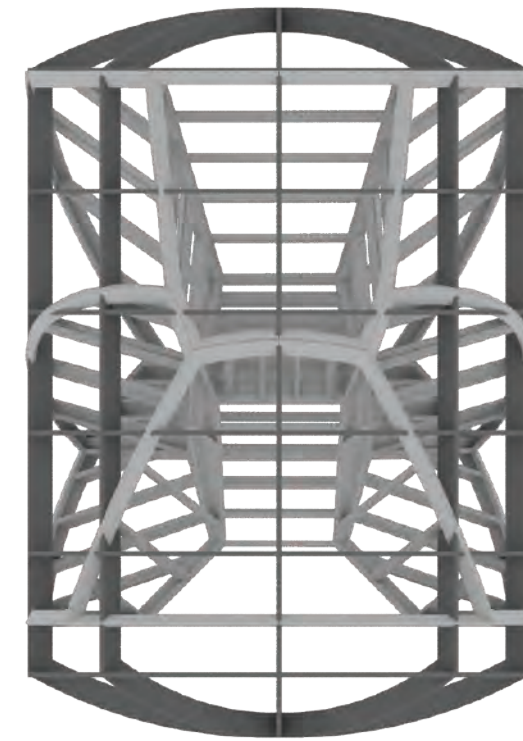

structure

The structure of the deep space habitat is the product of the GRASSHOPPER script that determined the spacial organization. Through a voronoi function, driven off of a desired geometry, the interior volumes took form. Using this script, a basic structural model could be created and extracted. After extracting the model, it can be manipulated more precisely to achieve a logical and efficient structural system. The GRASSHOPPER script also allows for data to be extracted, giving relevant information about the structure such as total volume which can aid in the calculation of weight.

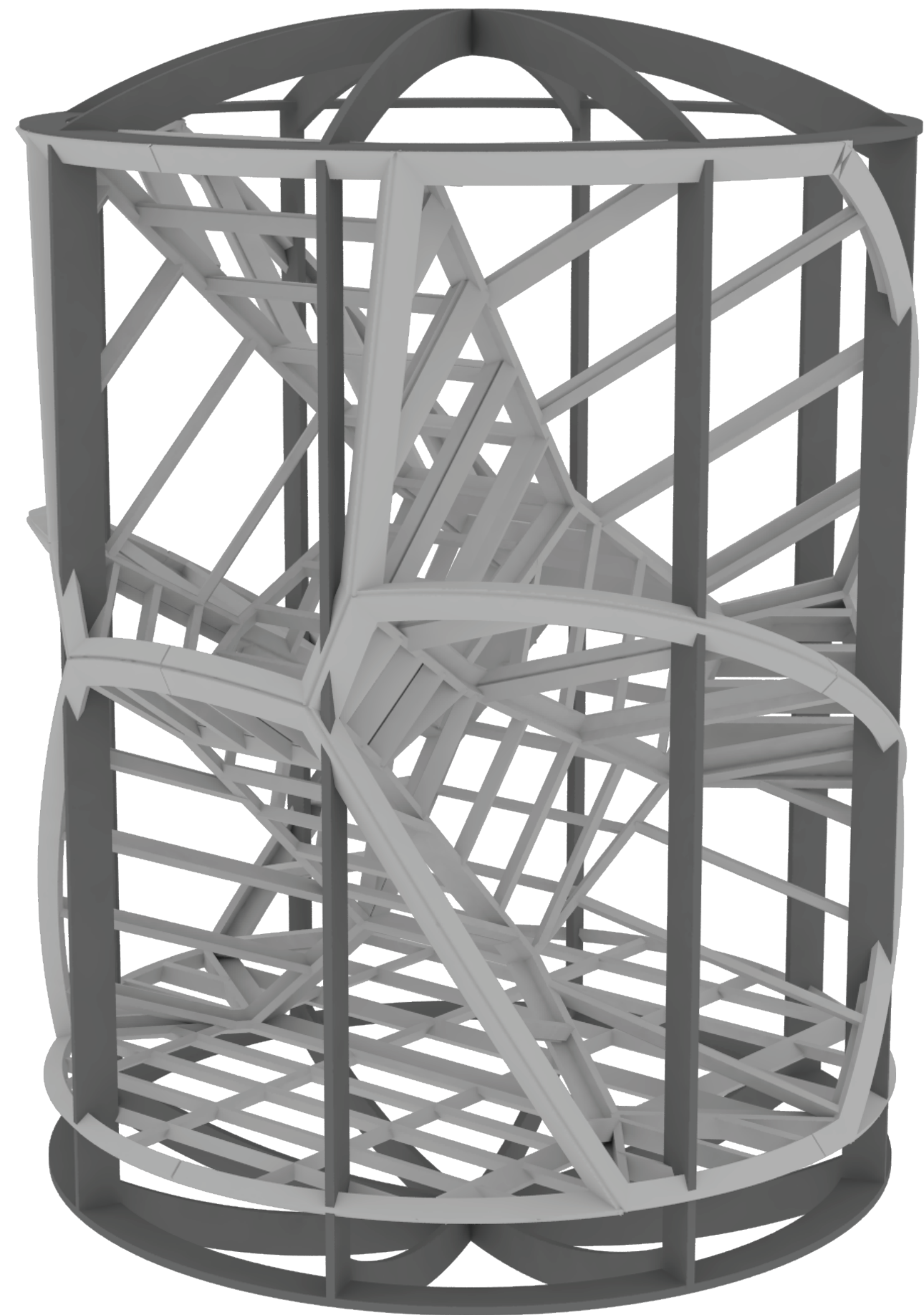

structure

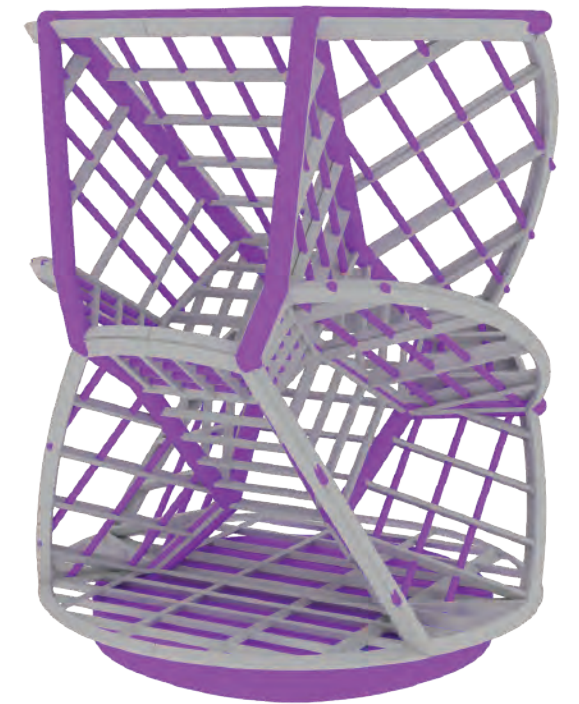
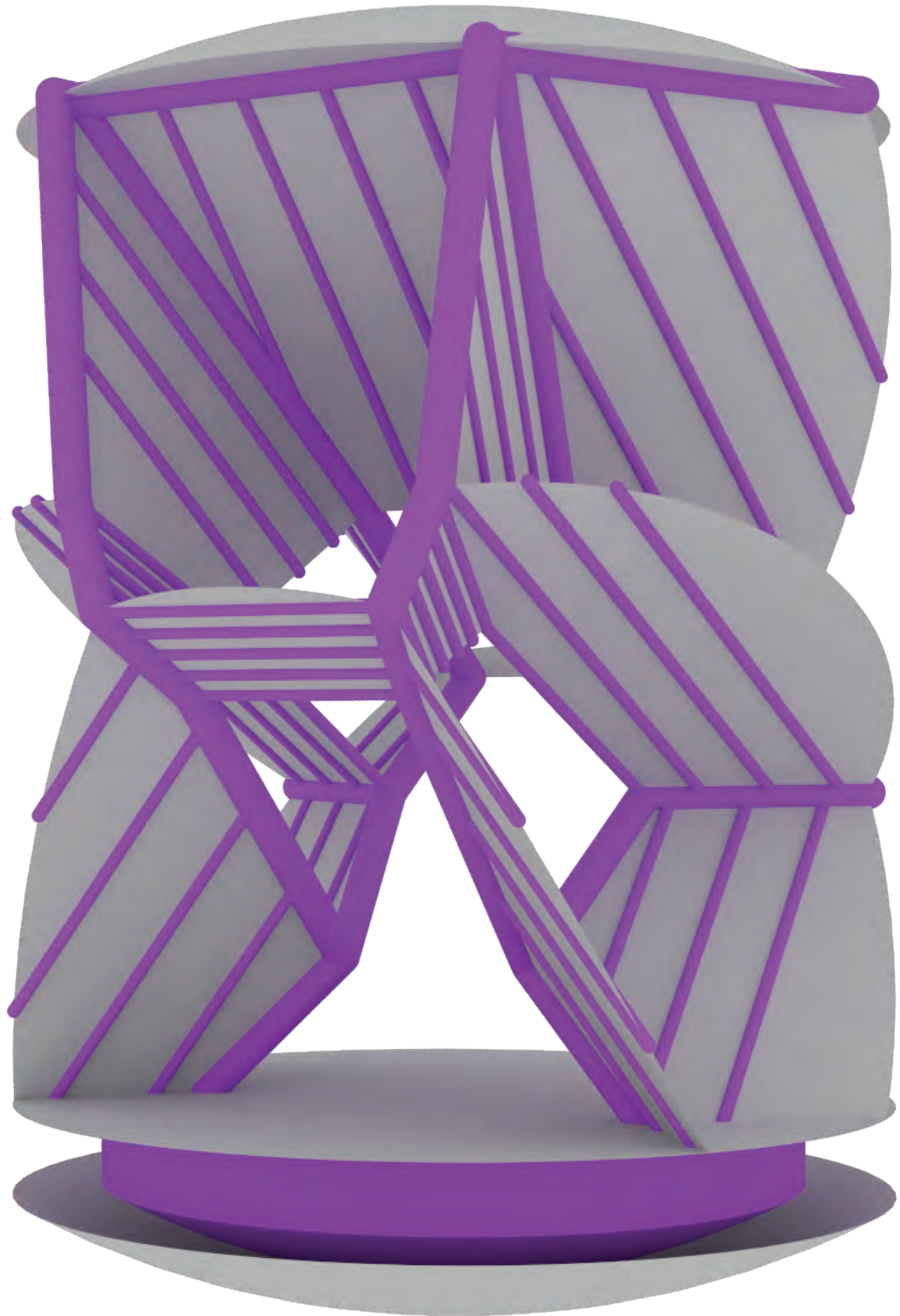

structure

The systems approach to the habitat is designed to utilize the space between the interior volumes to act as the channels for the electrical, mechanical, and plumbing systems. The heart of the major systems is located in an allocated volume at the base of the habitat. Those systems reach the habitable areas by branching upwards through the poche space in the interior partitions paralleling the structure. The system has major causeways to feed each space and smaller branches that extend into the partitions.

The systems and structure occupy the same spaces so they must be integrated with each other. The mechanical, electrical, and plumbing systems major paths utilize structural members as guides through the partitions. The branches extend perpendicular to the structural members, passing through perforations. This way all the systems can maximize the space between habitable volumes.

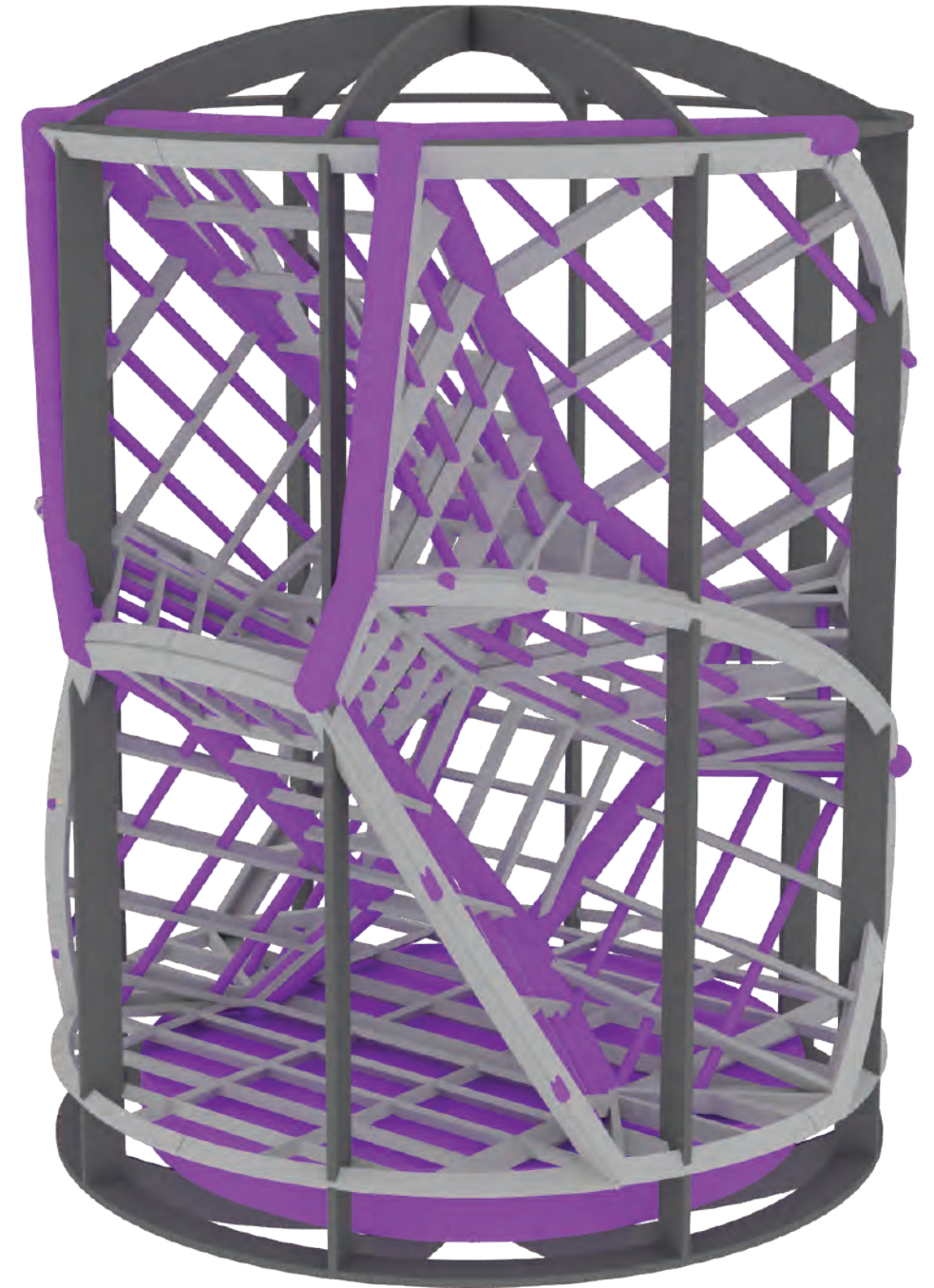

node design

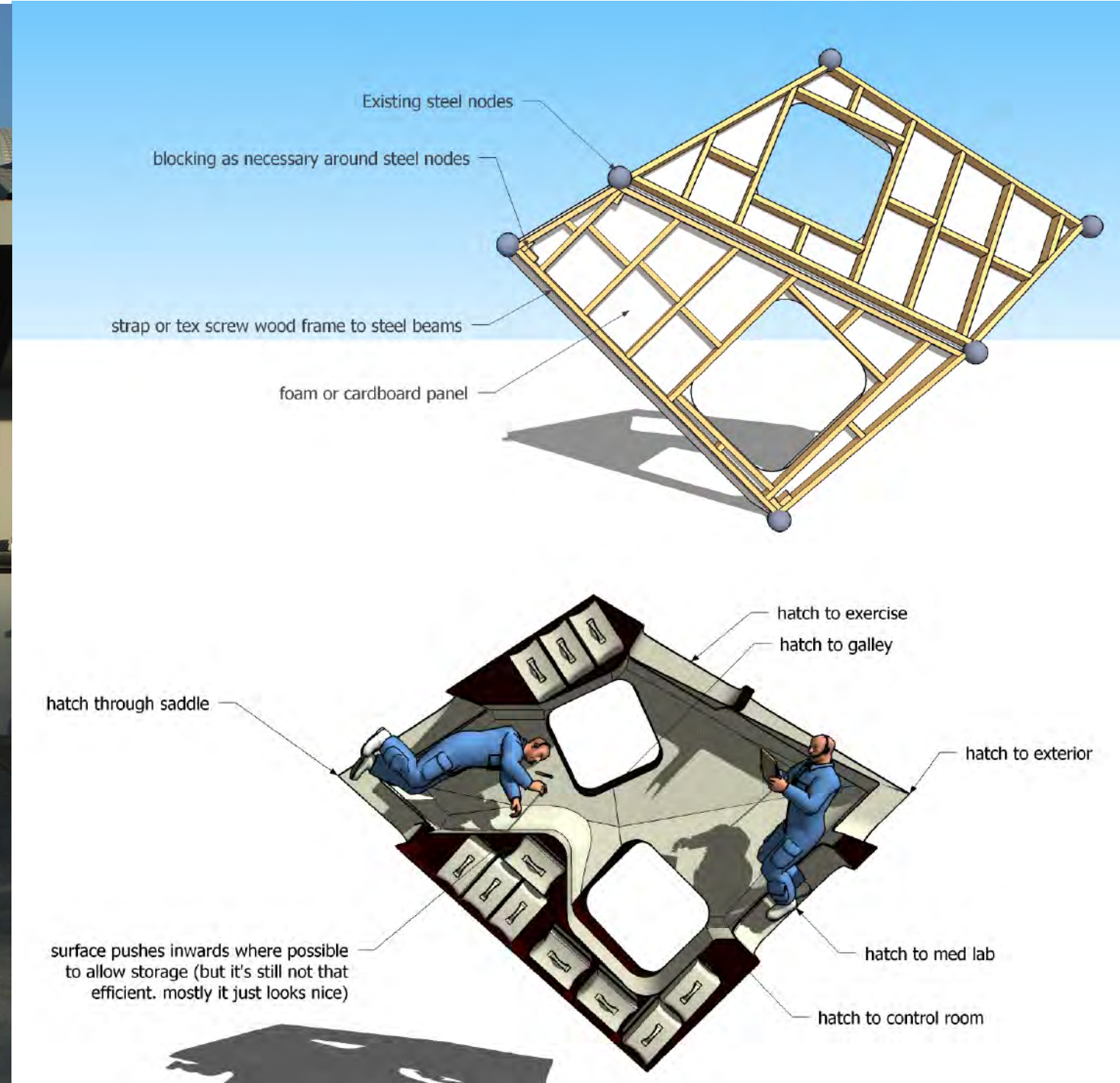

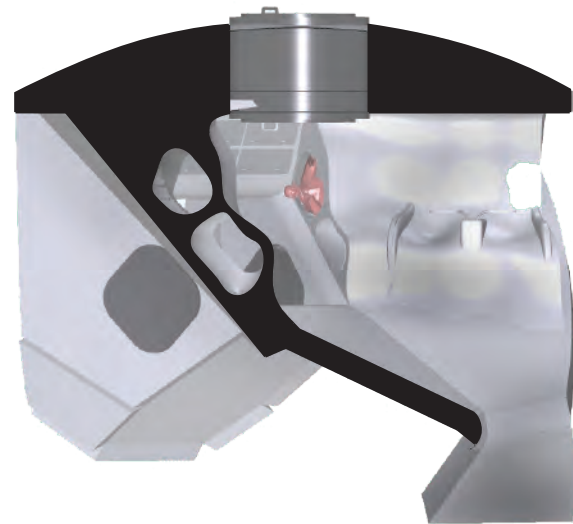
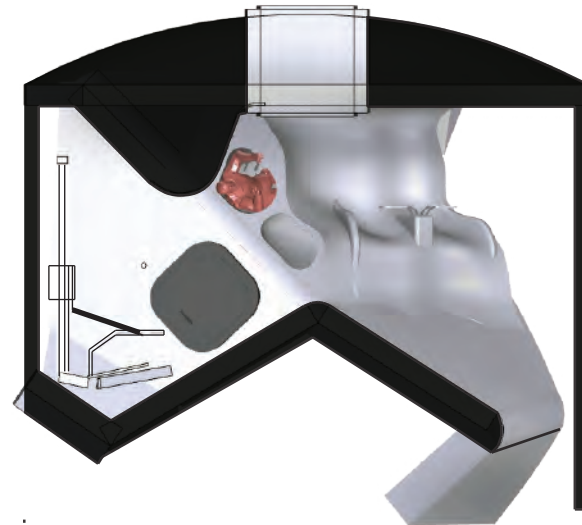
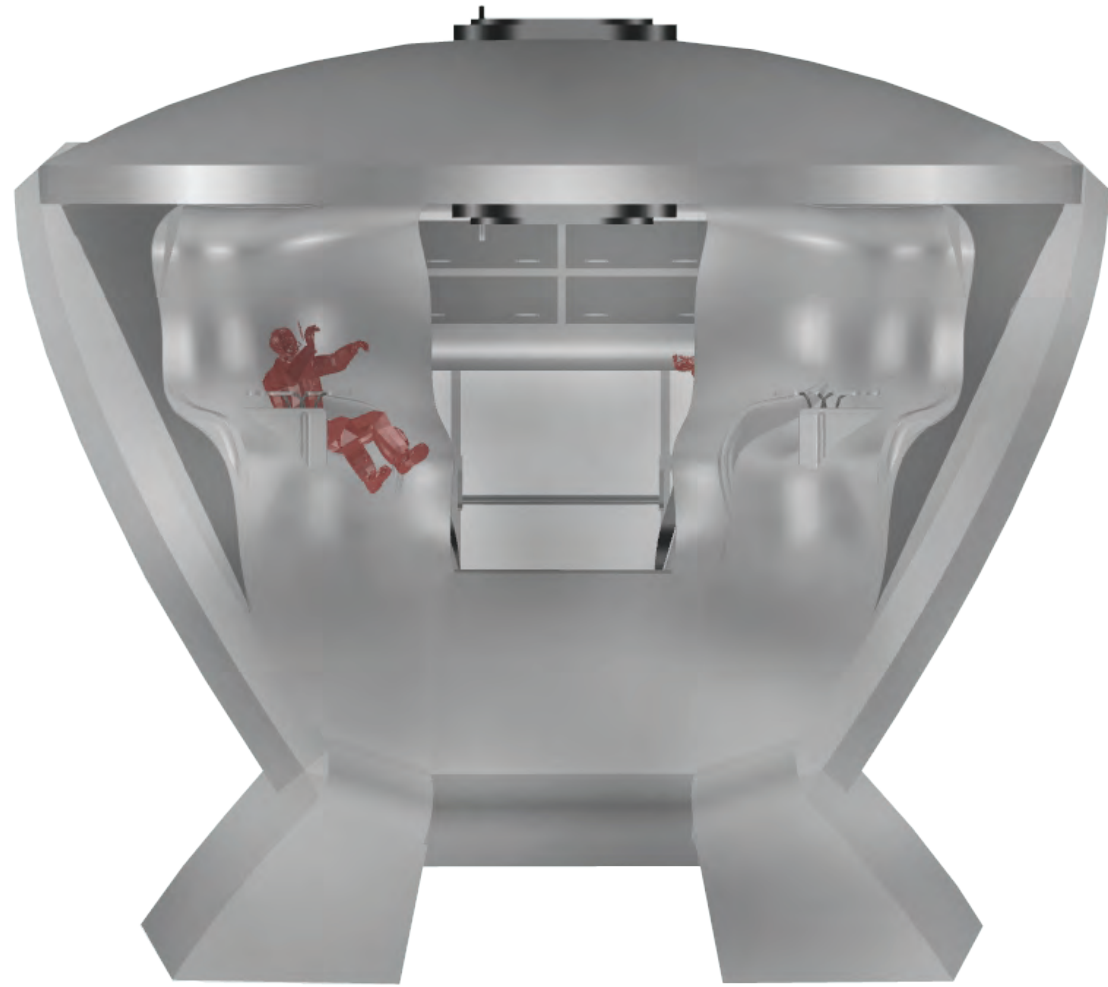

kitchen/galley

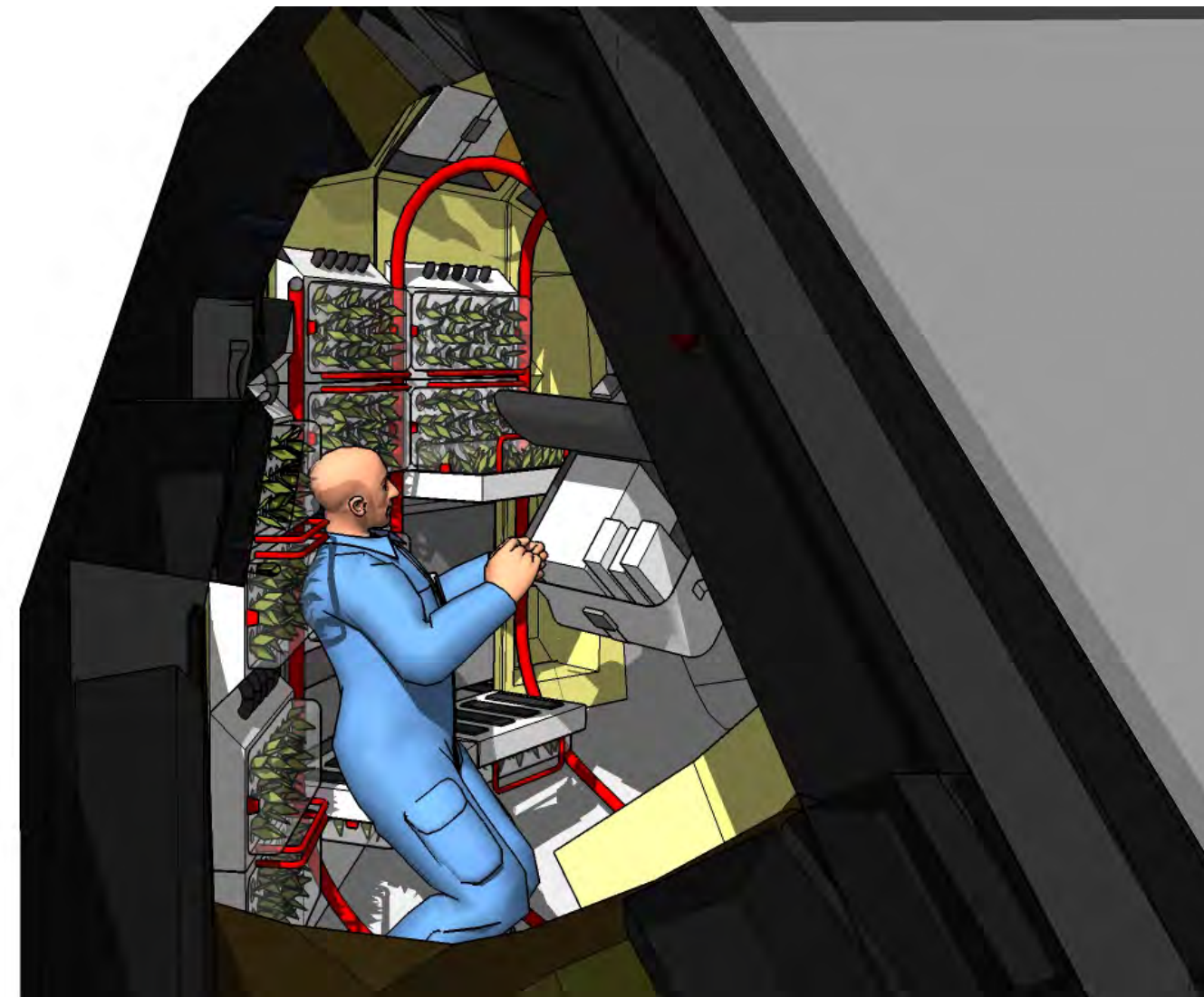
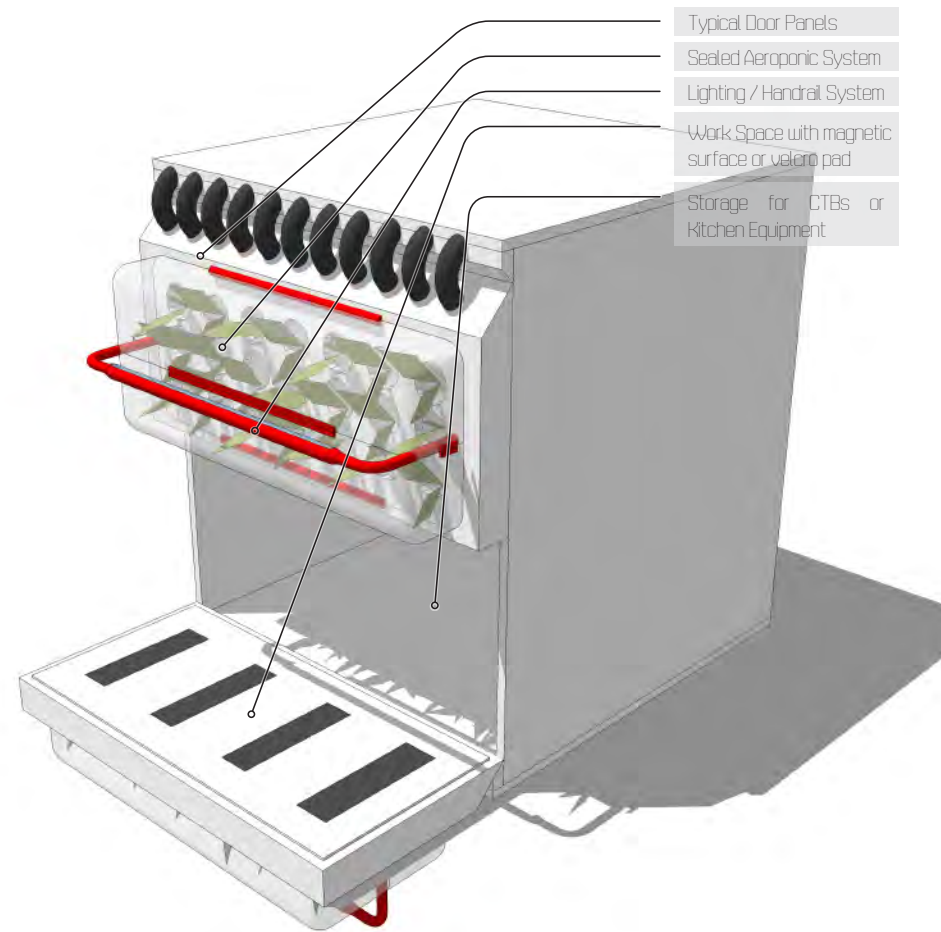

hygiene

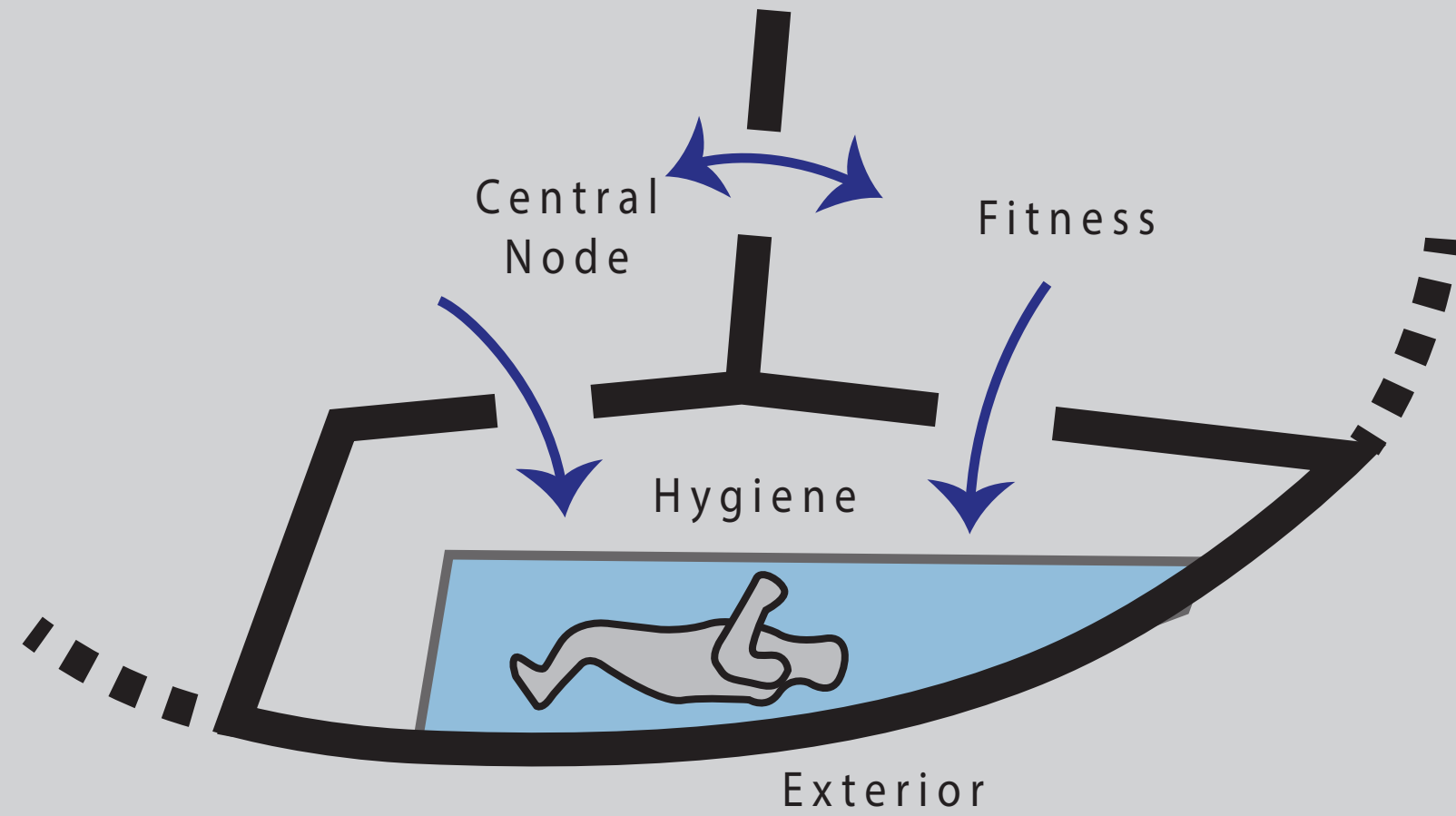
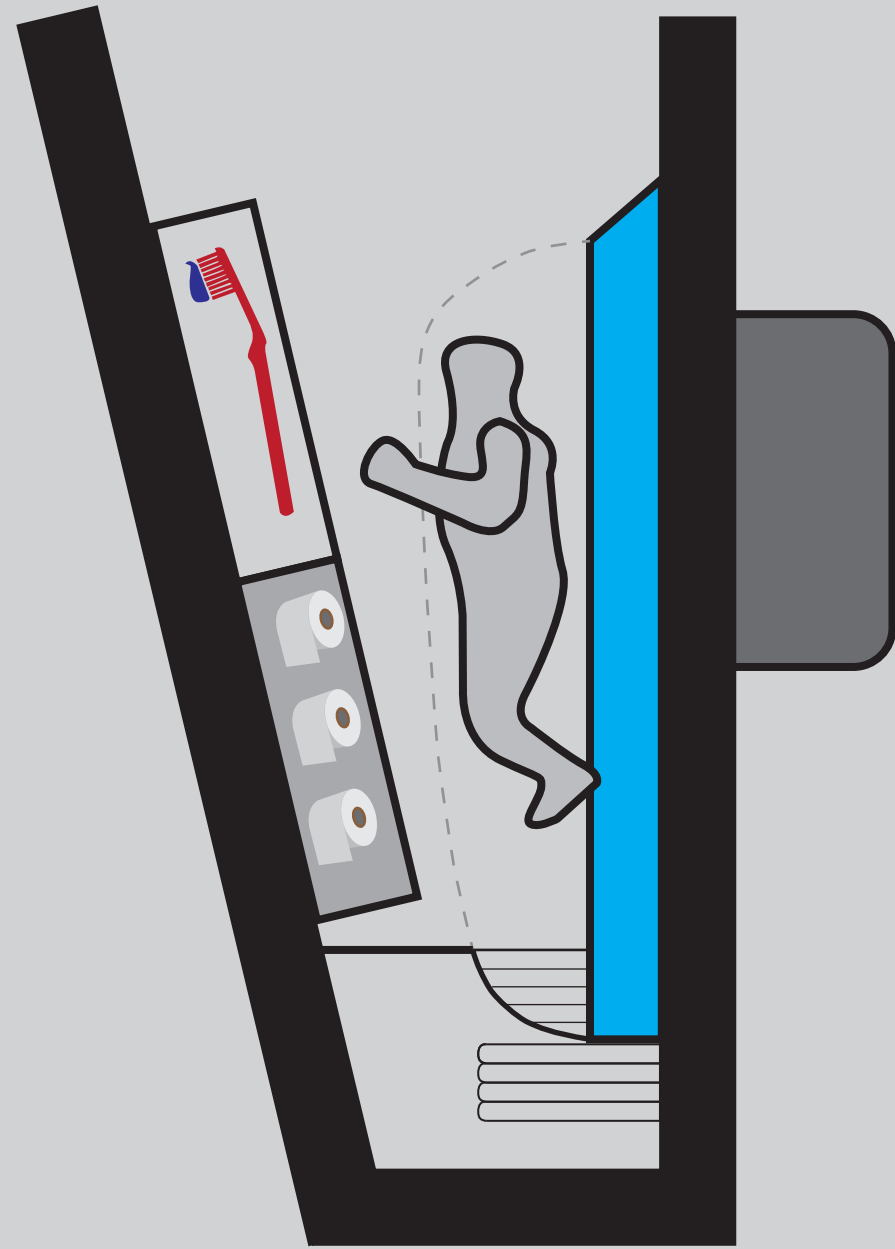

main workstation

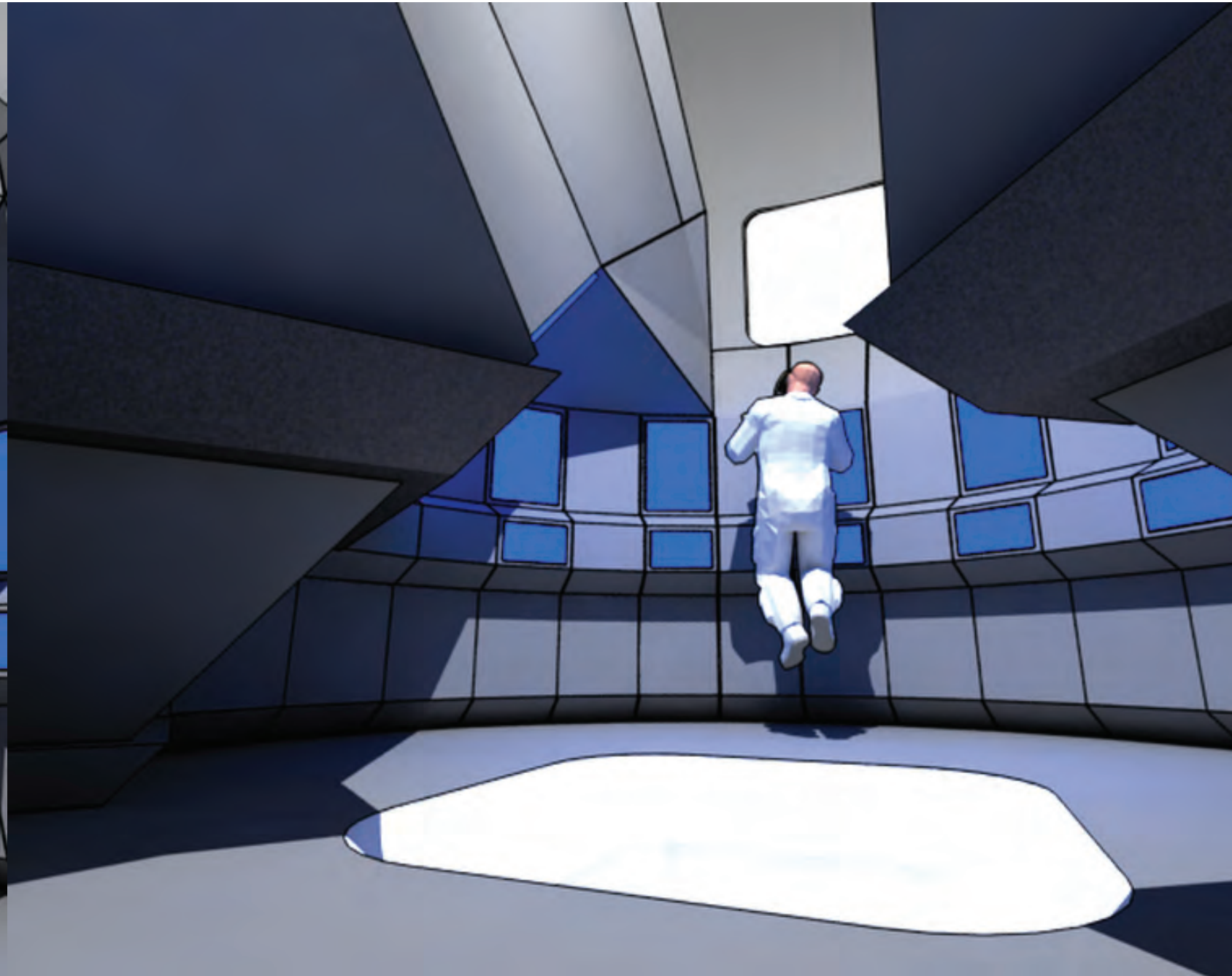
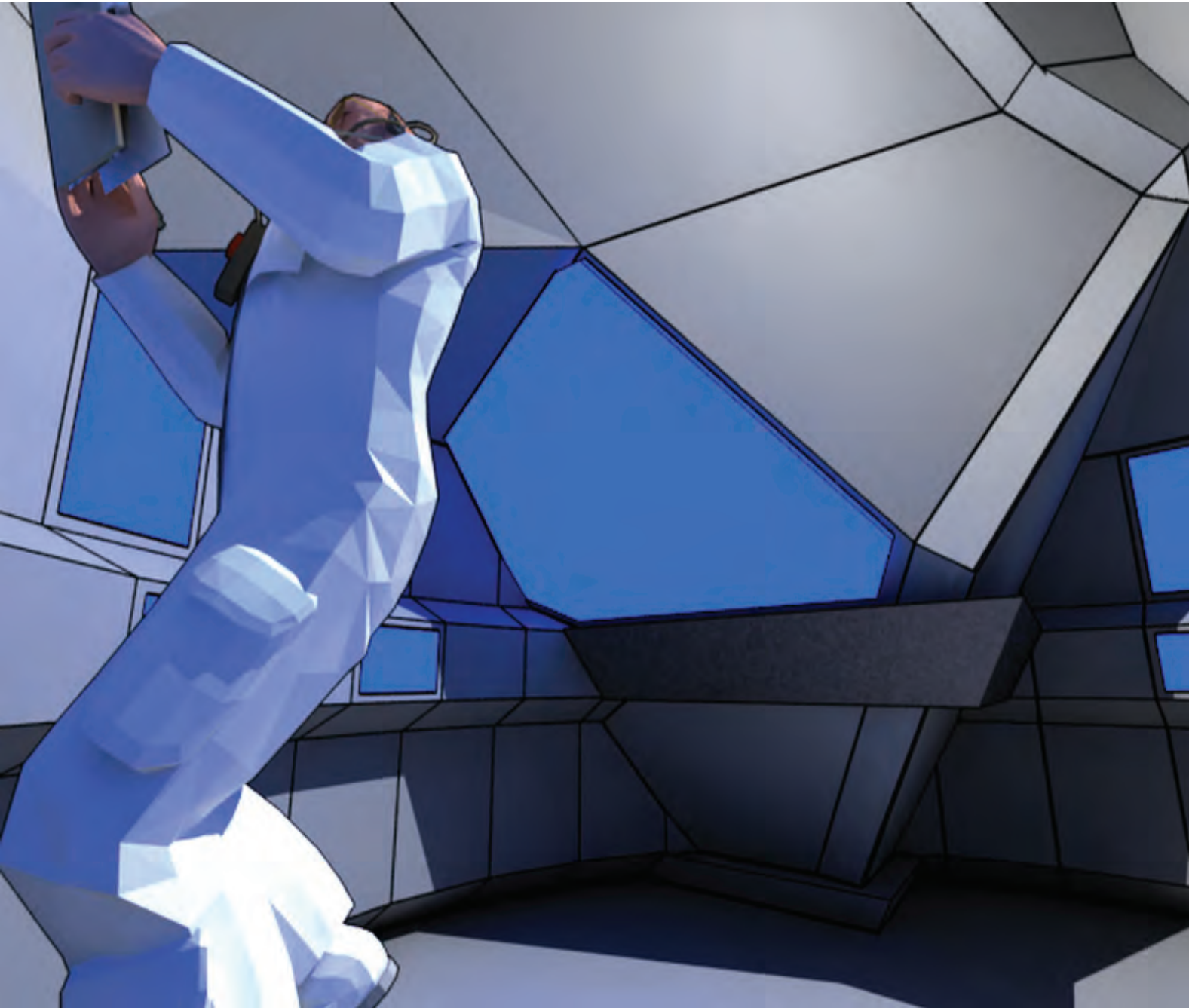

secondary workstation

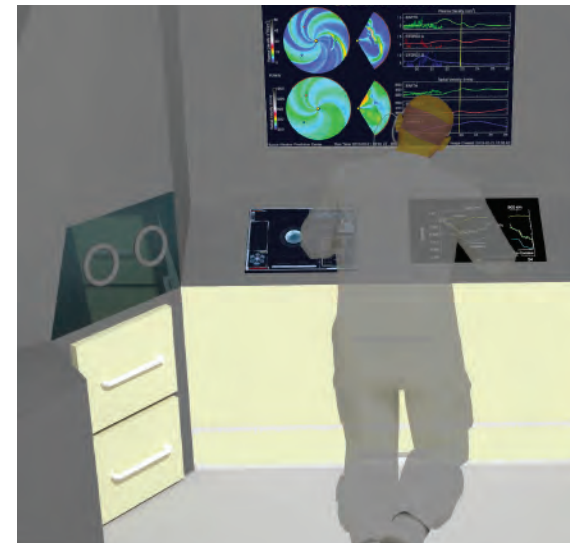

general maintenance

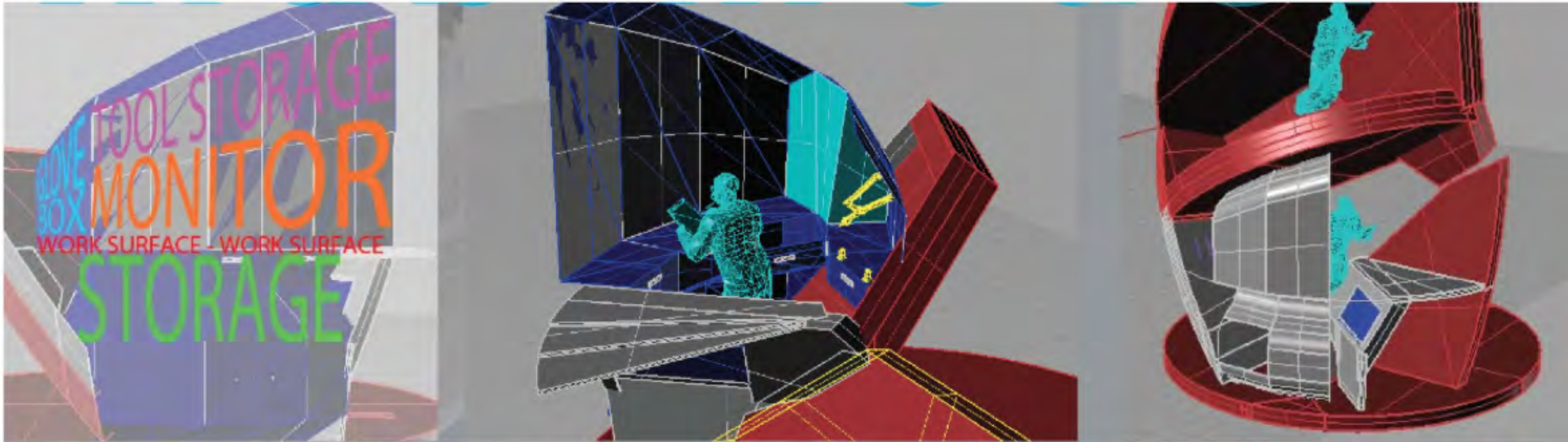

control room

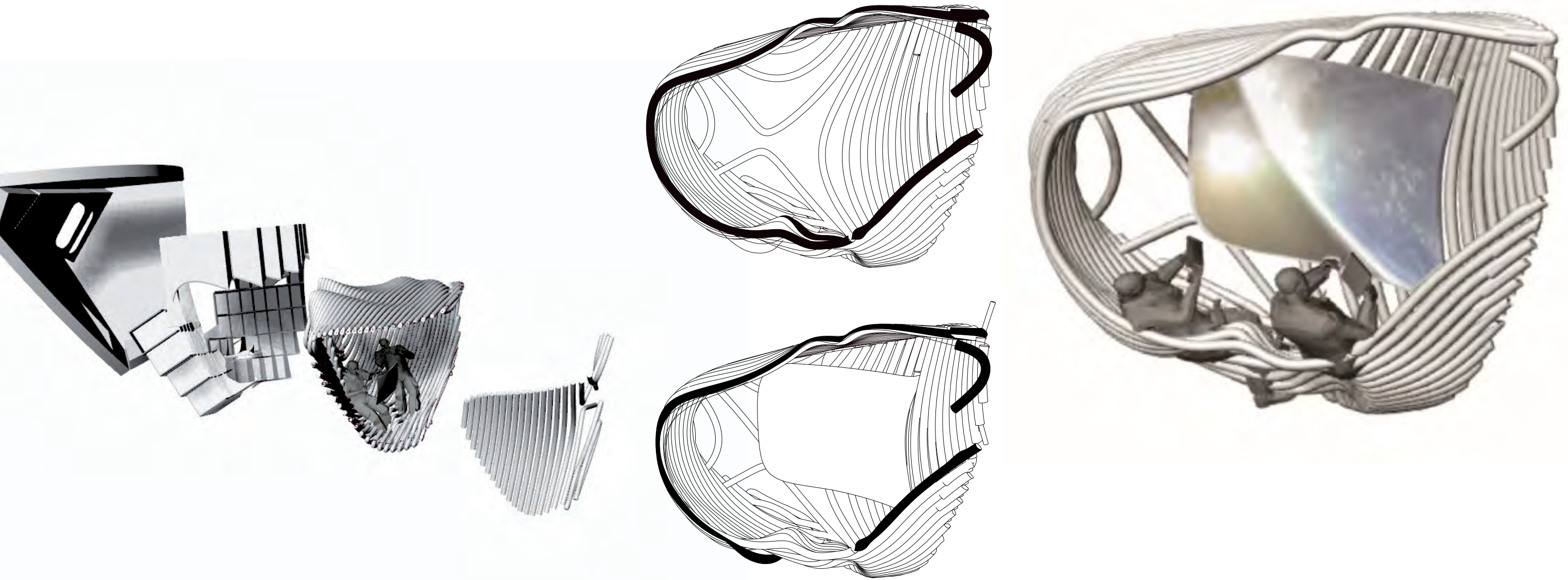

physical mockup



physical mockup



physical mockup



physical mockup



physical mockup



wind tunnel

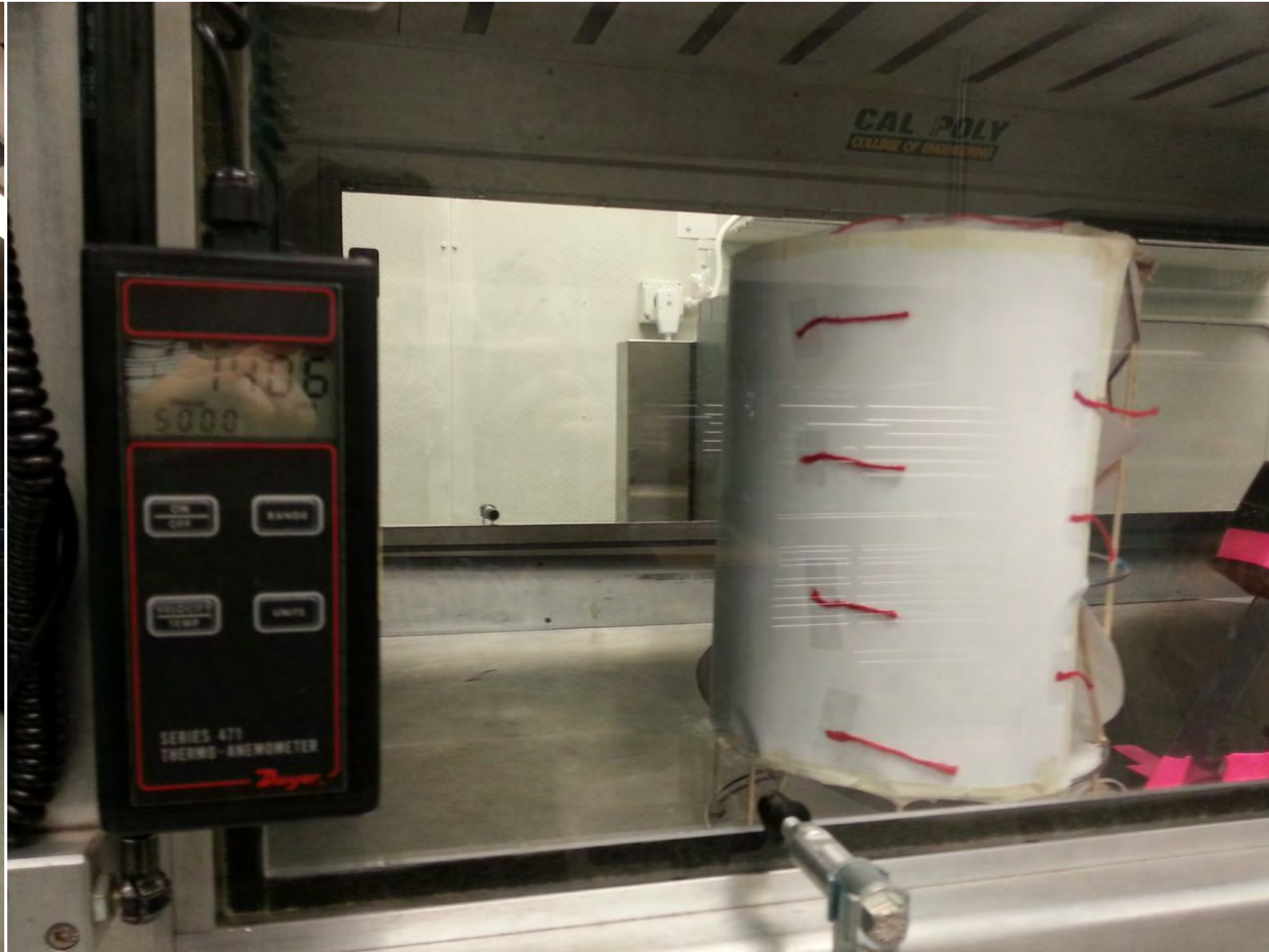



SPRING 2013

DIGITAL FABRICATION
AND
DESIGN CONTINUATION



objectives

[] Starting Spring 2013, the NASA studio moved forward with new guidance and team to complete the work of the work of the first two quarters of the 2012-2013 year. In the horizon, there were several new sub-goals and objectives.

- 1 Digital Fabrication
- 2 Tours/dissemination
- 3 Fieldtrip to Johnson Space Center in Houston, Texas
- 4 Workstation - Internship at Jet Propulsion Laboratory in Pasadena, California

JPL internship: FMW



1. FMW collapsed

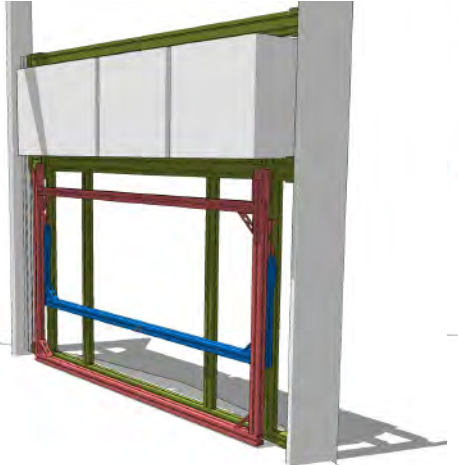

2. Work table unfolded

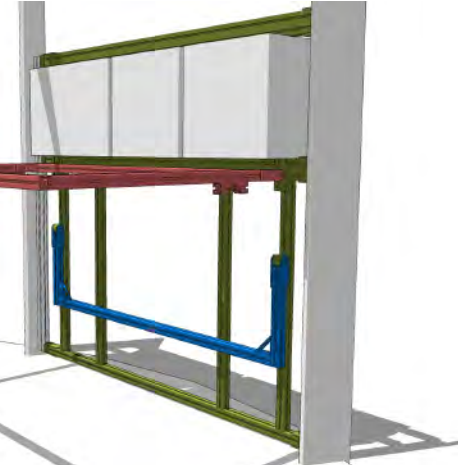

3. Work table bracing unfolded

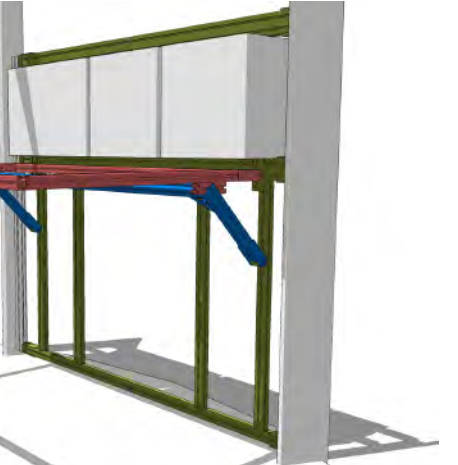

4. Machinery moved into place

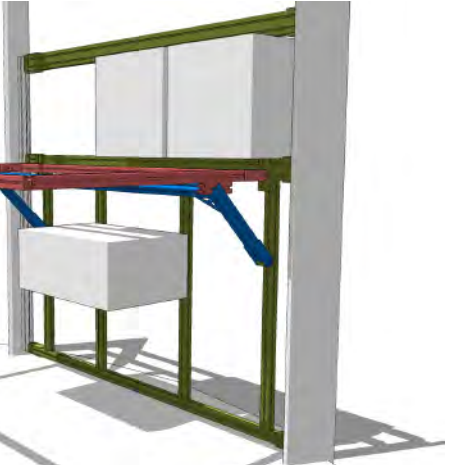

5. Dust containment hood attached

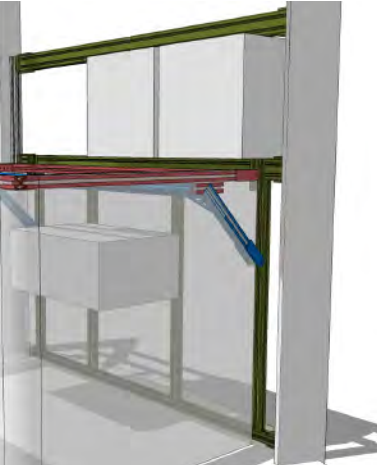

workstation

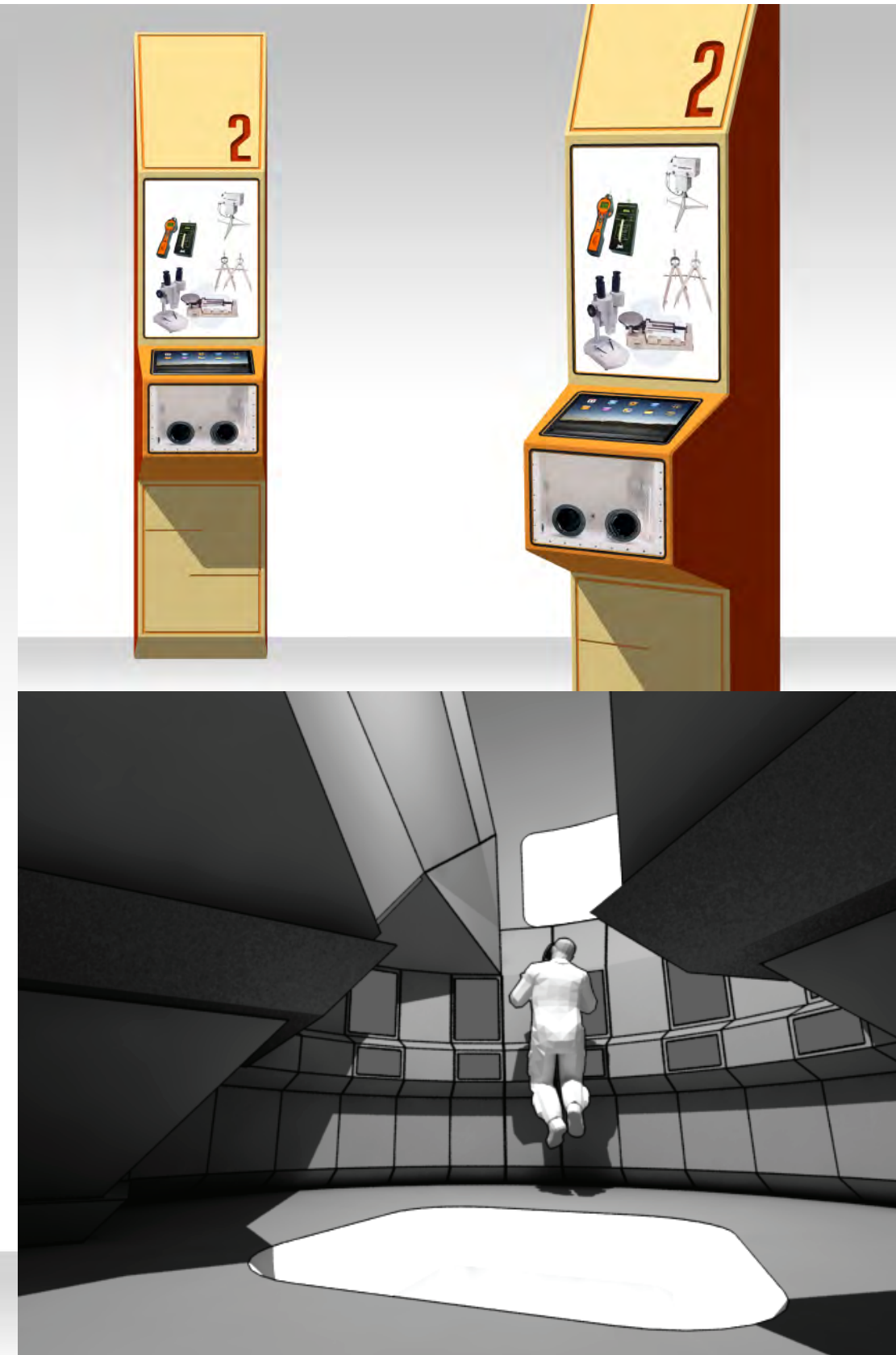
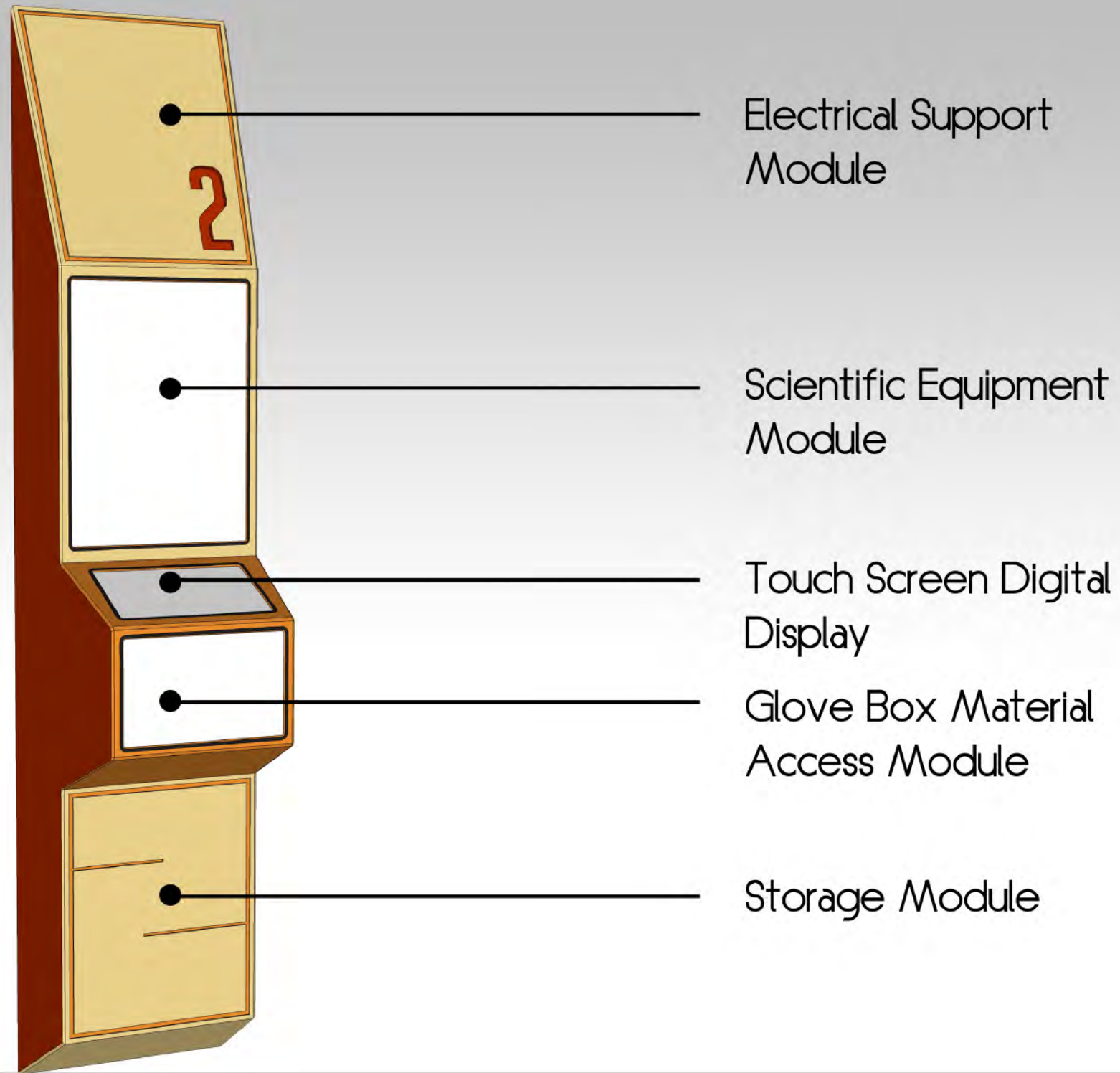

aperature window

VORONOI - natural system of maximum volume w/ minimum surface area

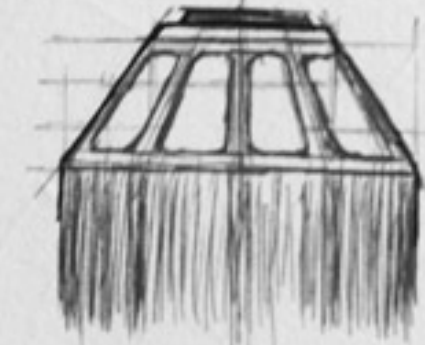
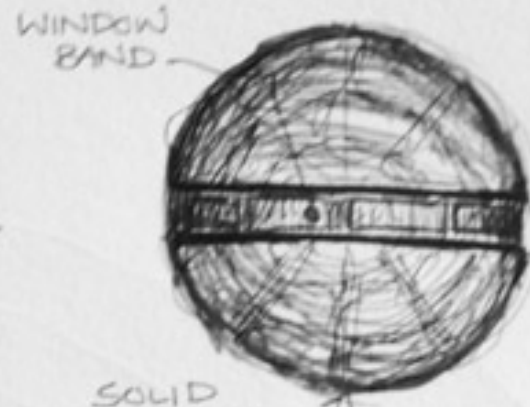
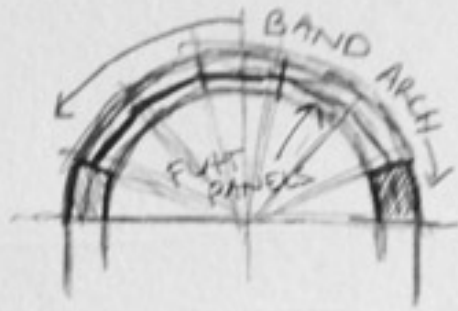
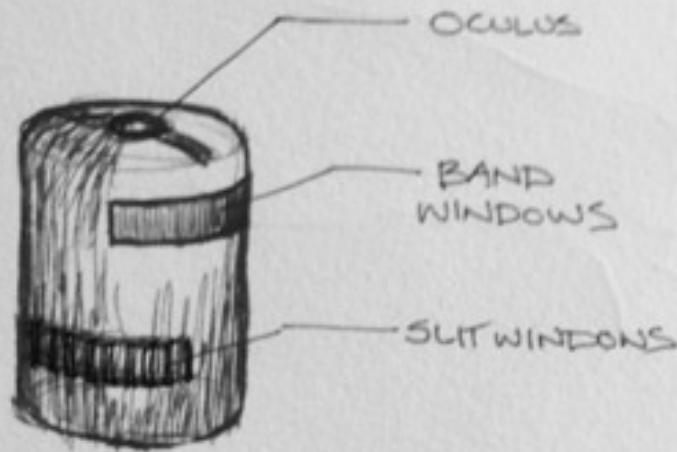

USE TEXT AS WINDOWS OR LADDERS...

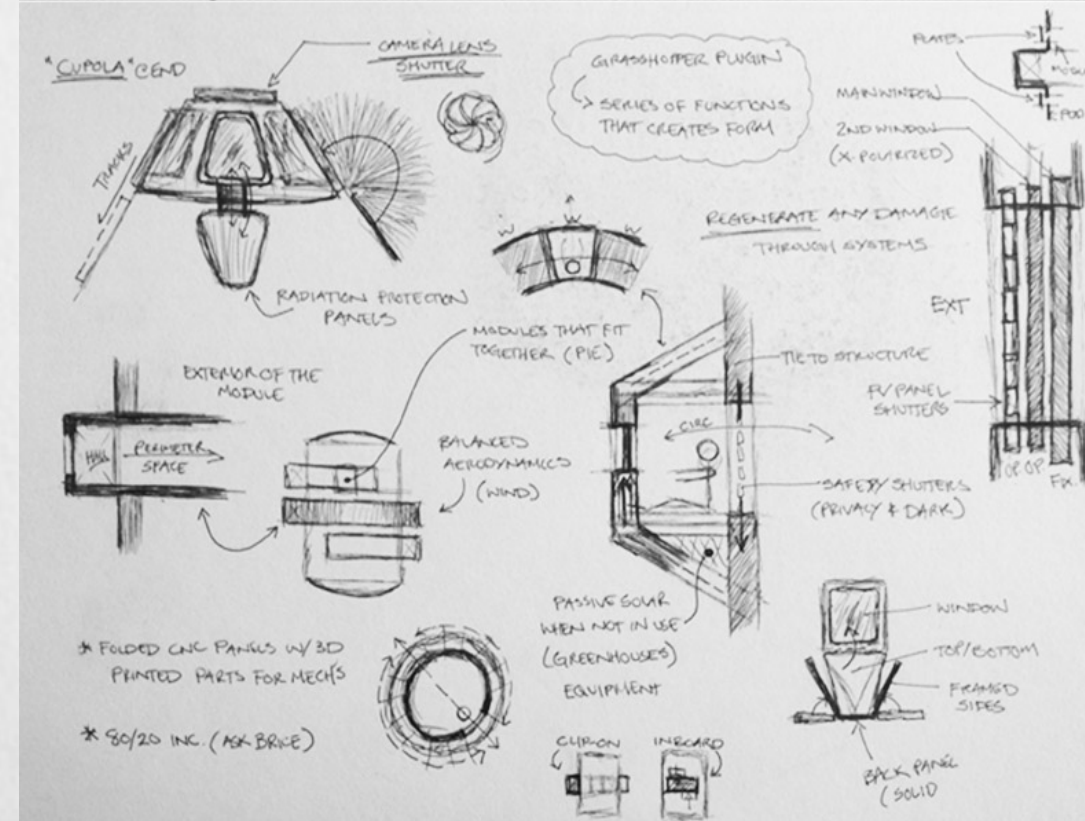
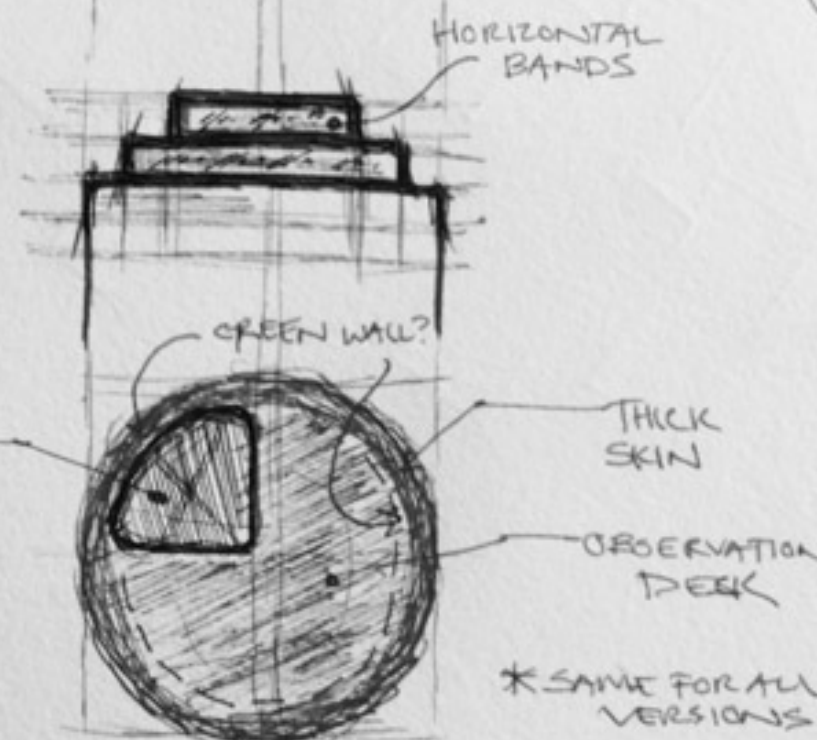
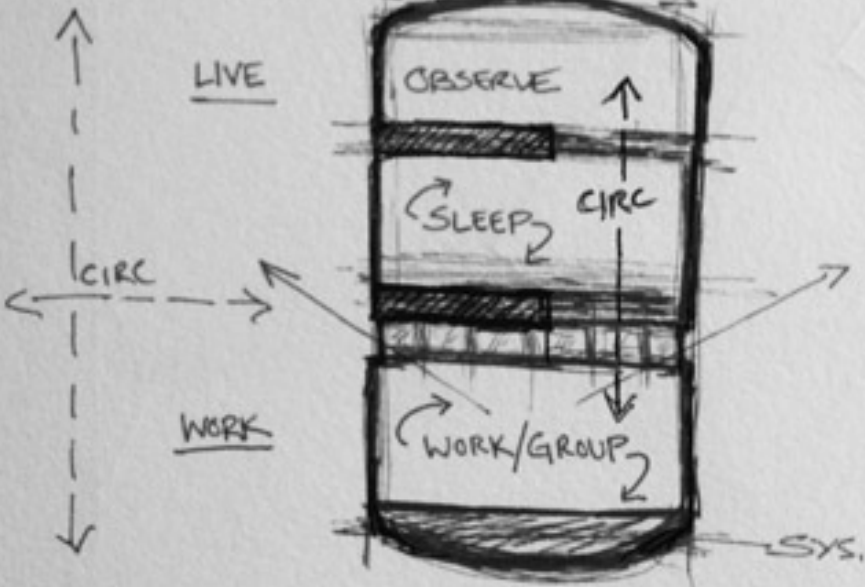
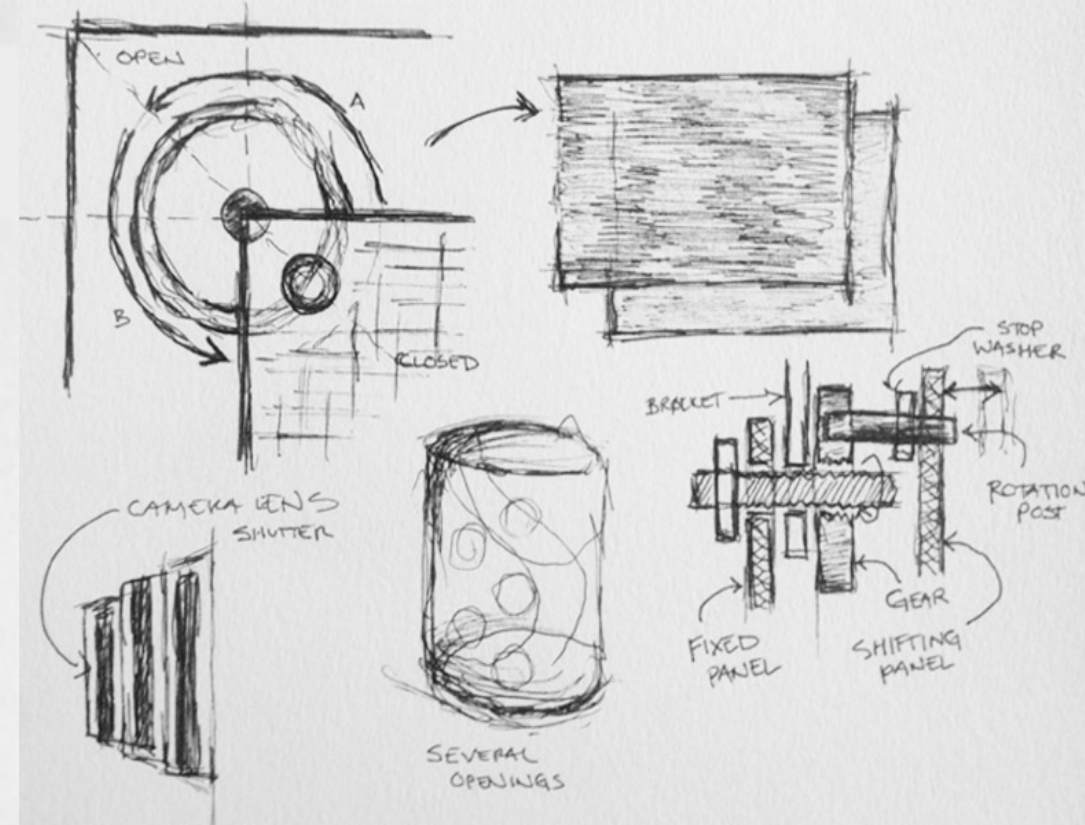

* CLIP ON & INBOARD VERSIONS

* BUILD OUT OF 80/20 EXTRUDED ALUMINIUM (LIKE AN ERECTOR SET)

AREA ENTRANCE PORTAL

* SAME FOR ALL VERSIONS

aperature window

- Window concept came from the aperture mechanism of a camera lens.
- Window works as follows:
 - User slides finger on the sensor strip
 - Operates small gear, which then turns the larger gear (outer ring)
 - As outer ring turns, one pin in each blade pivots while the other pin moves along a guided slot
 - This action allows each blade to open/close a controlled amount, thereby allowing the user to control the amount of light in the interior space
- Window created to reconnect astronauts with earth (otherwise not featured in design)
- Psychological benefits of natural daylight and visual connection
- Opens and closes with use of ribbon ^{sensor} (linear Spectra Symbol)
- 6 windows that are on one panel of the module to allow access from both work and live sectors
- Although some components would have to be steel, actual window structure could be made up of carbon fiber, metal and other plastics (any that could provide radiation protection)



aperature window



parabolic mirrors

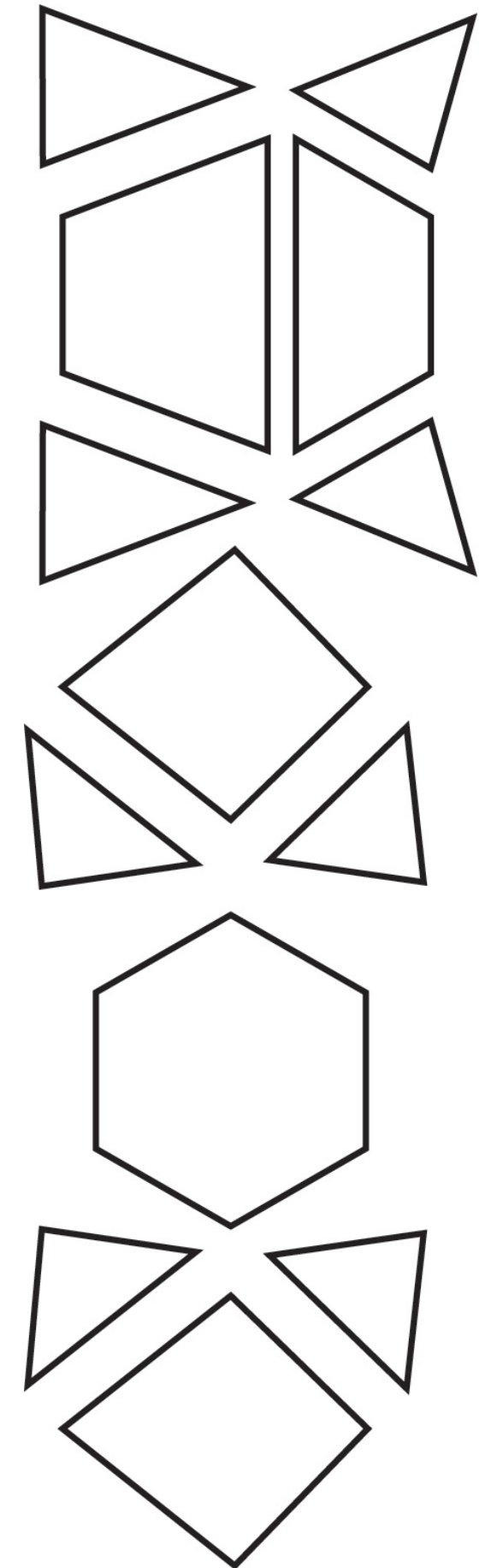
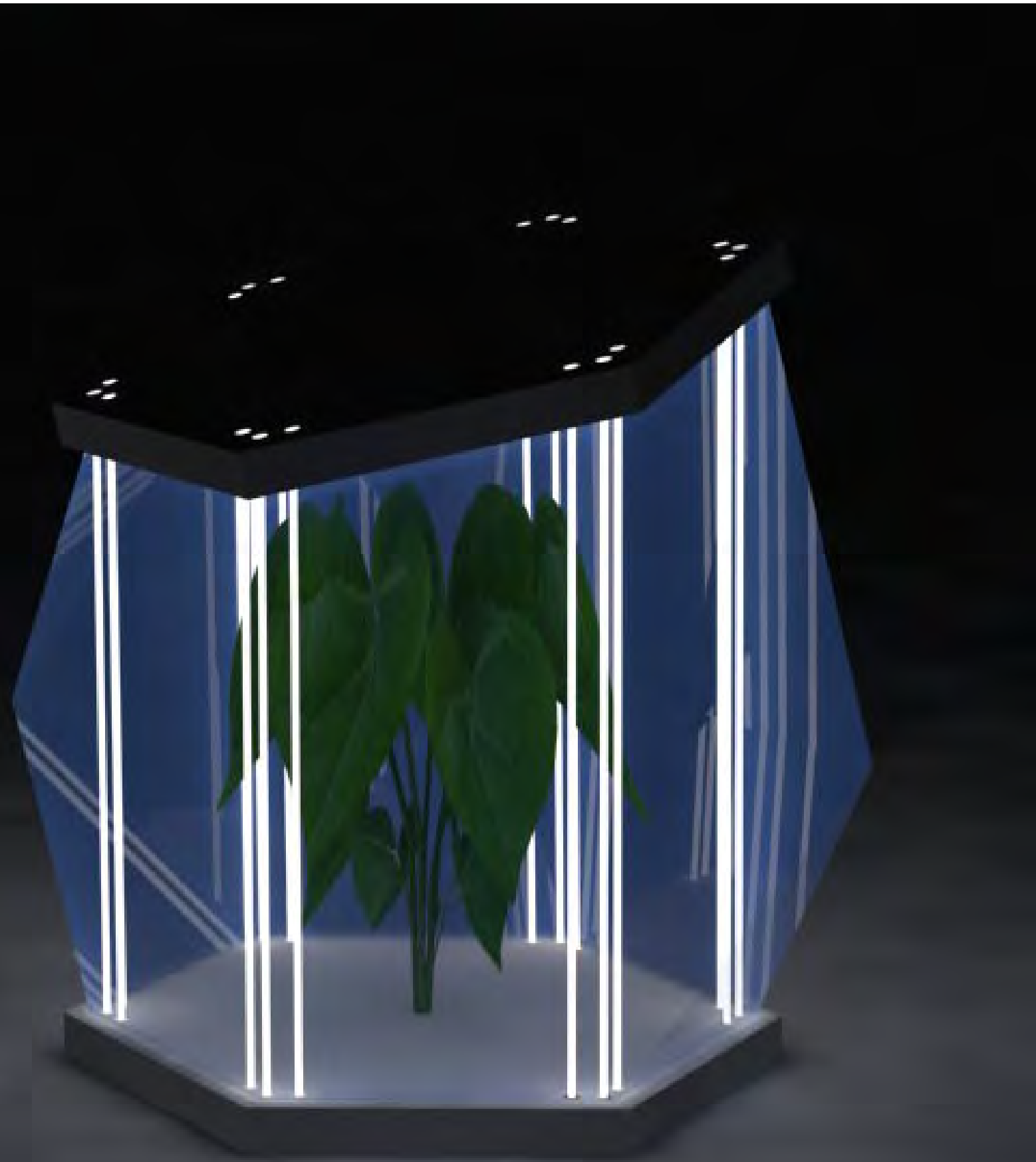

parabolic mirrors

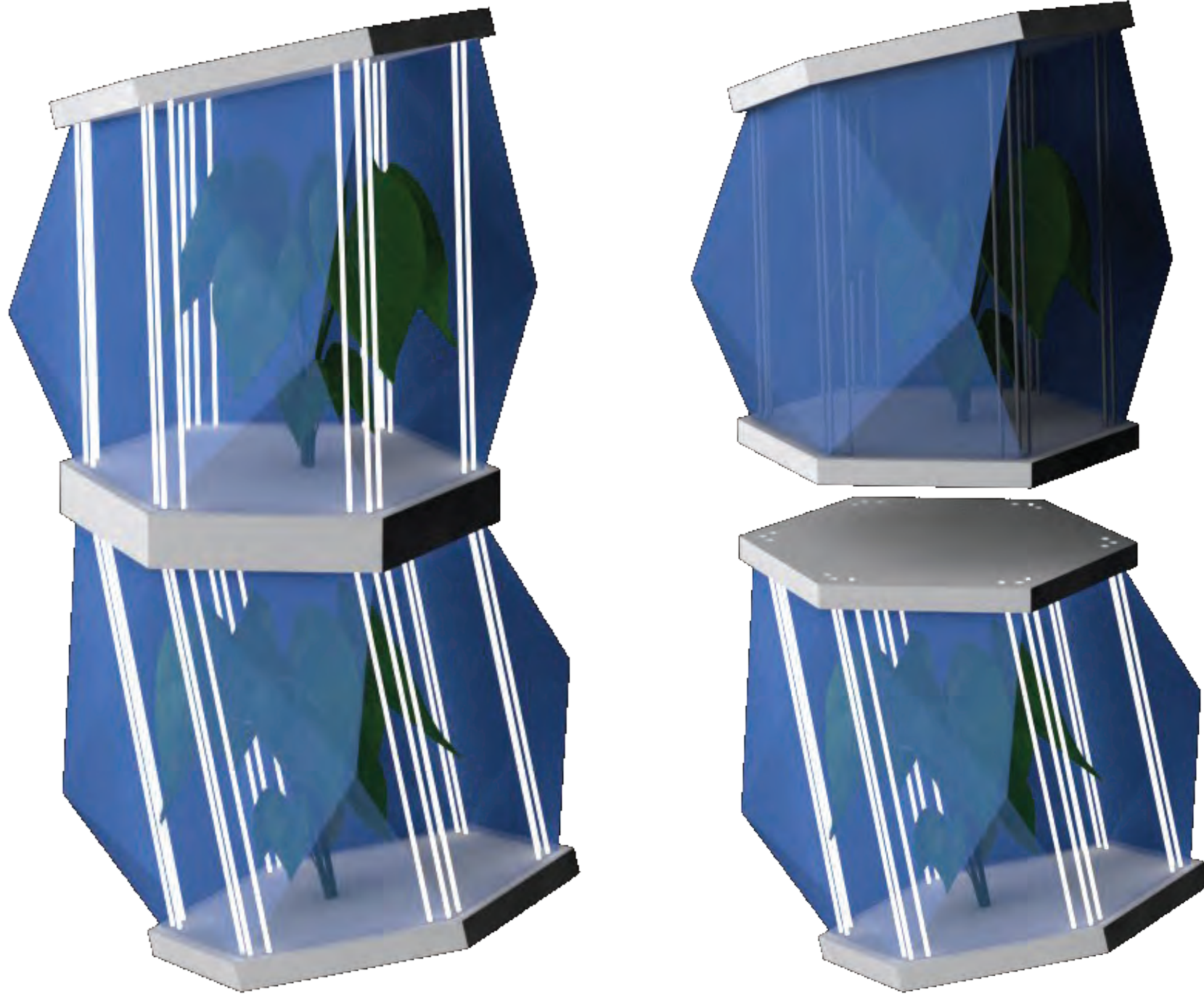

- Food growth allows us to provide small amounts of herbs and fresh fruits and vegetables to the astronauts.
- The plants also provide a connection to nature and a constantly changing element within the habitat, all of which is psychologically beneficial to the astronauts.
- Aeroponic systems use far less water and nutrients than conventional farming, and are also cleaner and more sanitary, because they do not involve soil (as in conventional farming) or standing water (as in hydroponics).
 - Plants' roots hang freely in air and are regularly sprayed with a mist of nutrient-rich water
 - Our innovation here was to integrate the system into a simple module that can be interconnected and used throughout a space module as both a source of food and a source of light through the use of fiber optic wires. These wires provide the plants with the necessary solar light they need while providing ambient light for the astronauts.

hand/footholds

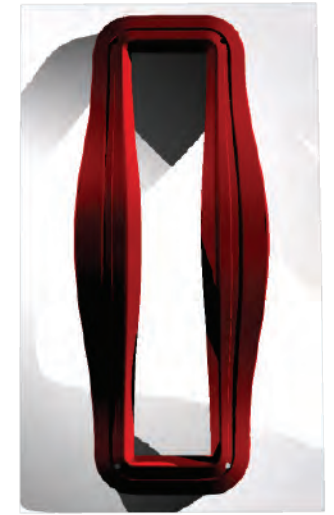

hand/footholds



- This project is the design of a handhold/foothold that addresses:
 - Where people are
 - Where things are
 - What is being used
 - What things are broken
 - How things can be repaired or re-fabricated
- The Handhold / Foothold ergonomically designed to be used in several different configurations: in parallel or at 45 degrees for the feet
- Each entire component is 3-d printed (this one is 1/8" structural acrylic) but they could be printed from any material
- The point is that they can be entirely fabricated on-board with in-situ materials
- Each component has 6 sensors embedded into it which include:
 - two occupancy sensors on each side of the handle that let you know where a person is in the ship and even infer their orientation
 - Four stress sensors that let you know the amount of stress on each joint where the handle is secured to the habitat. These sensors have three levels of stress including critical failure so that you are notified if something is broken.

hand/footholds



hand/footholds

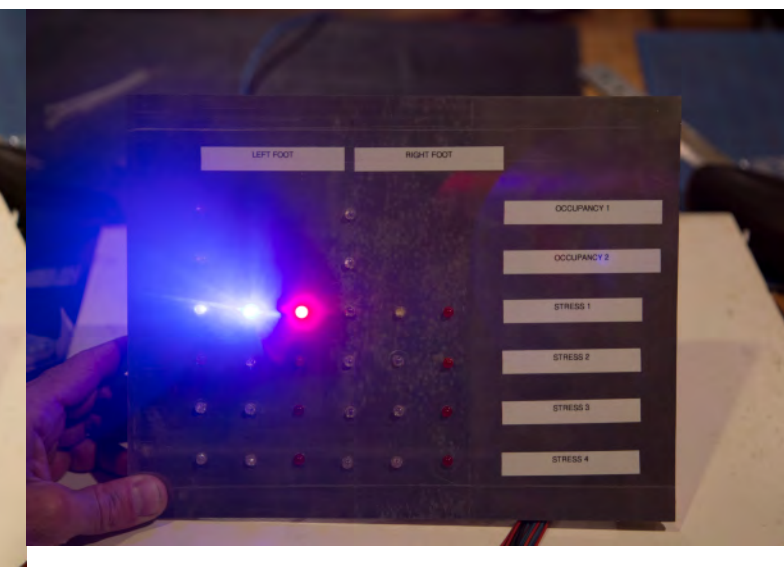
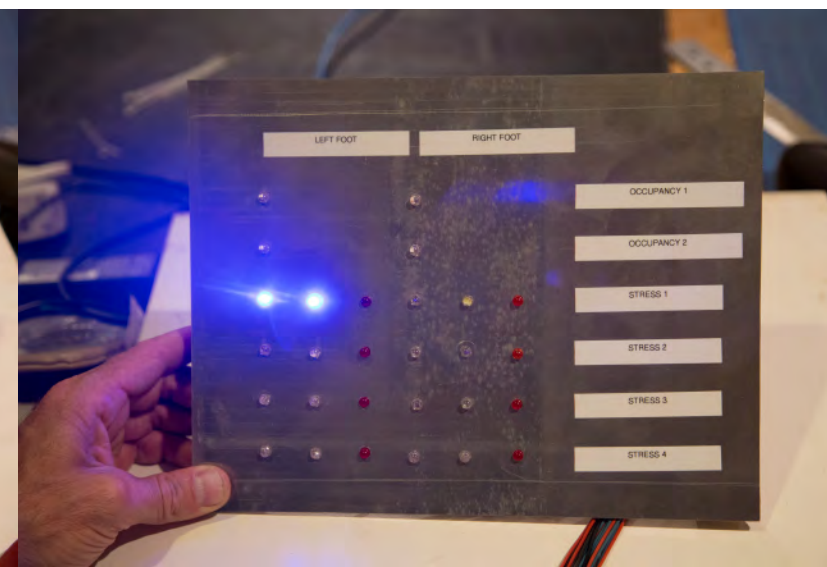
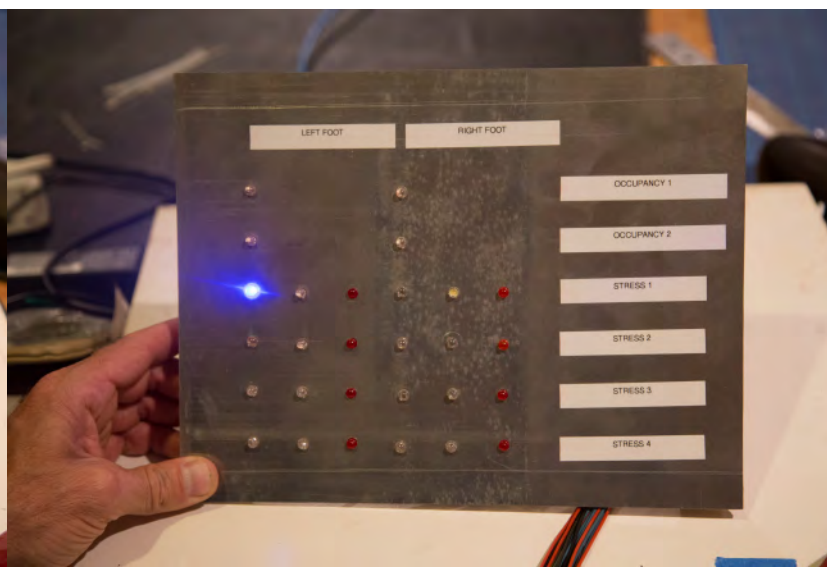
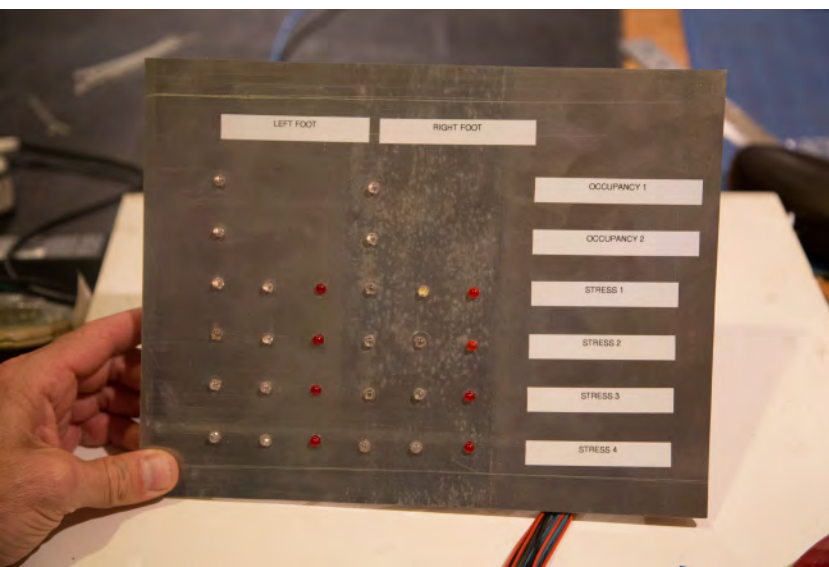
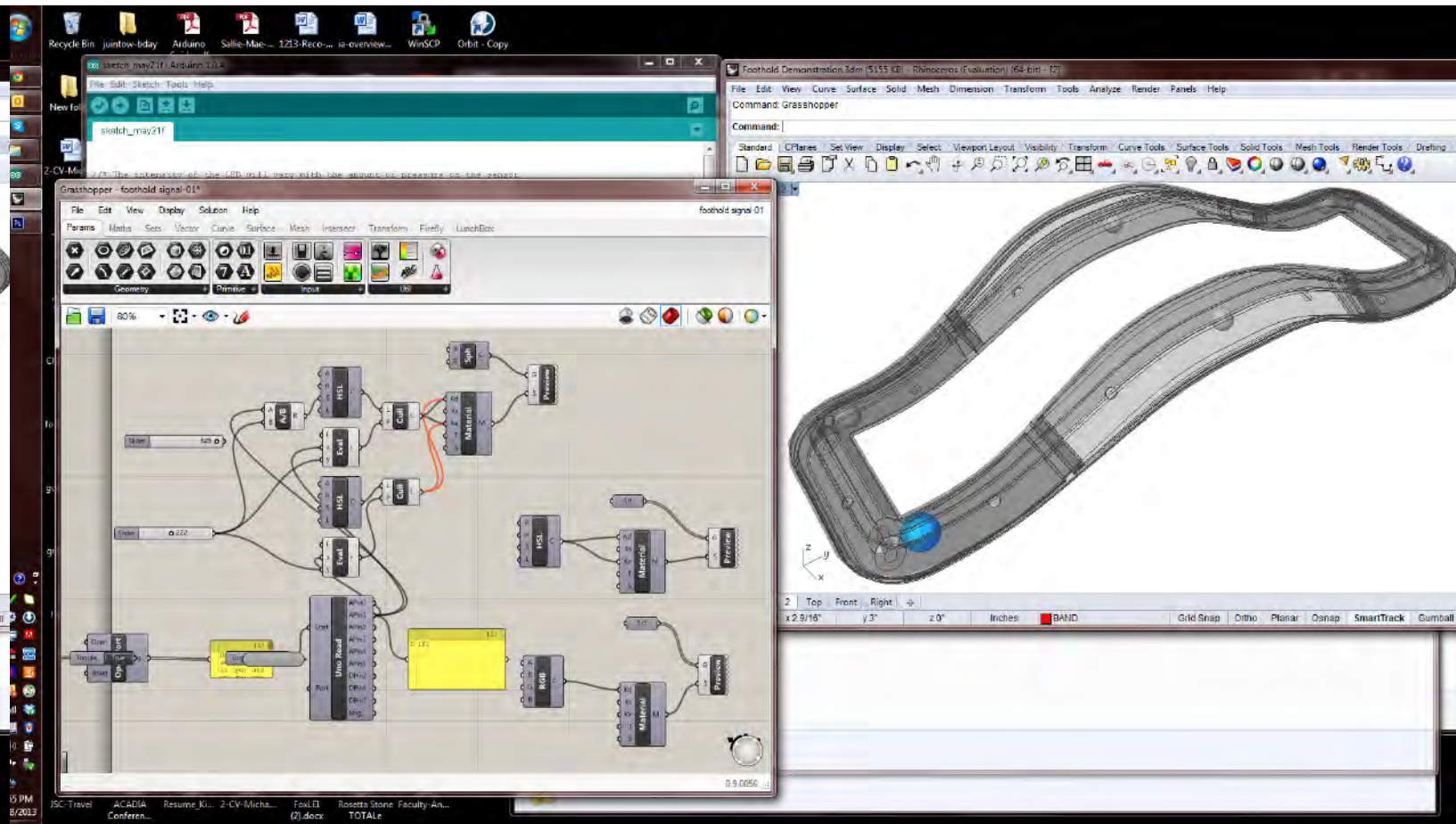
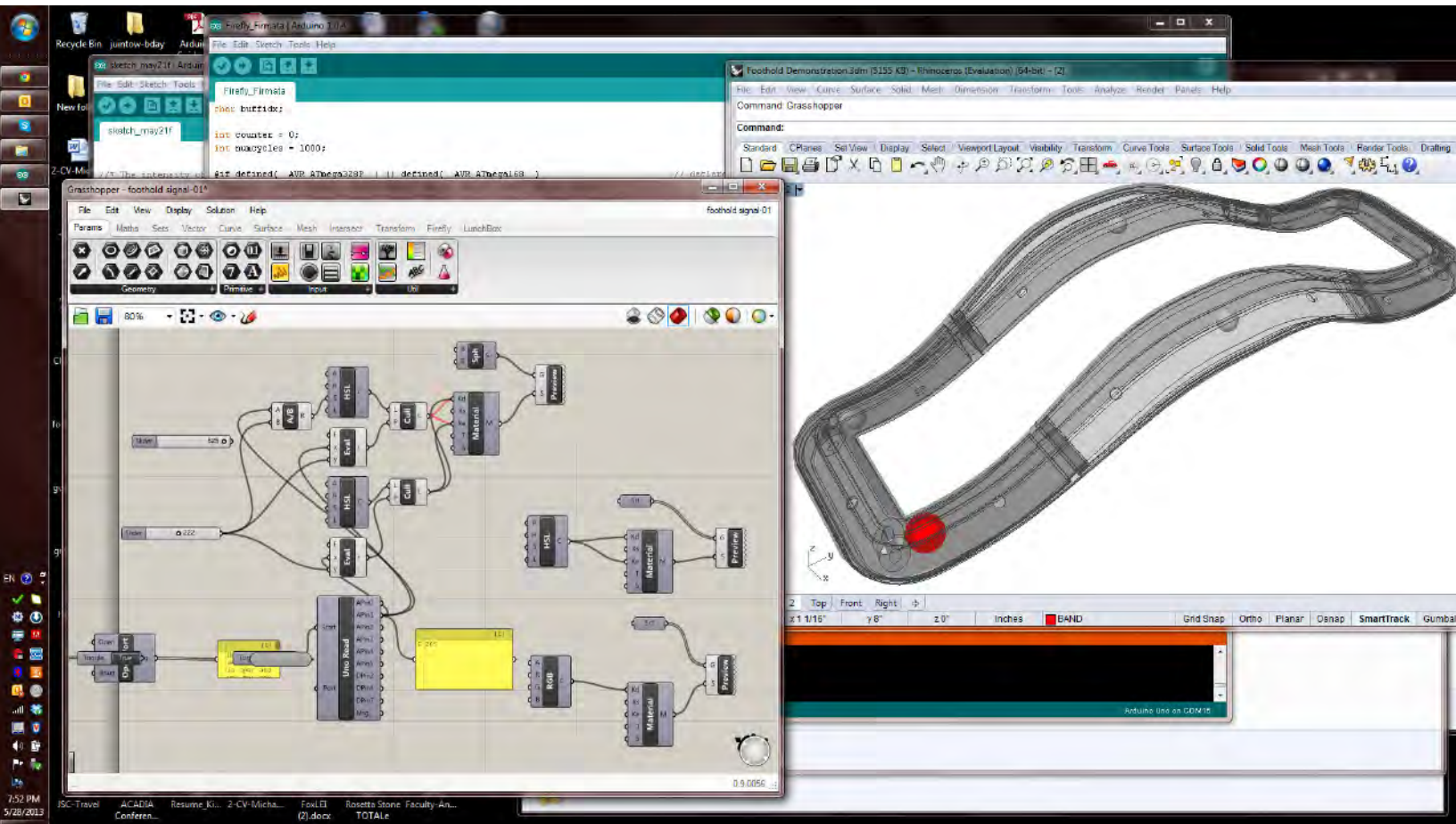

hand/footholds

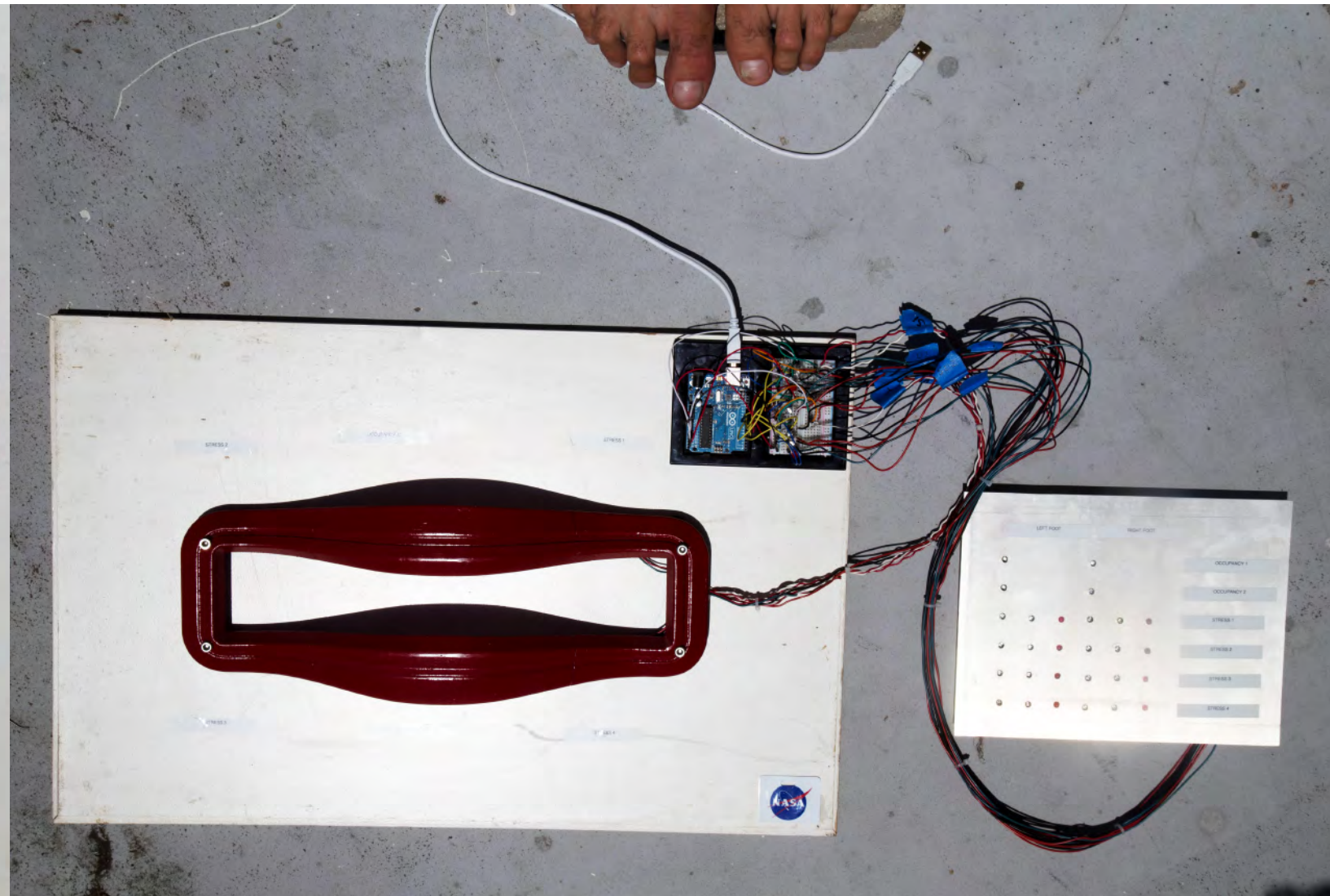
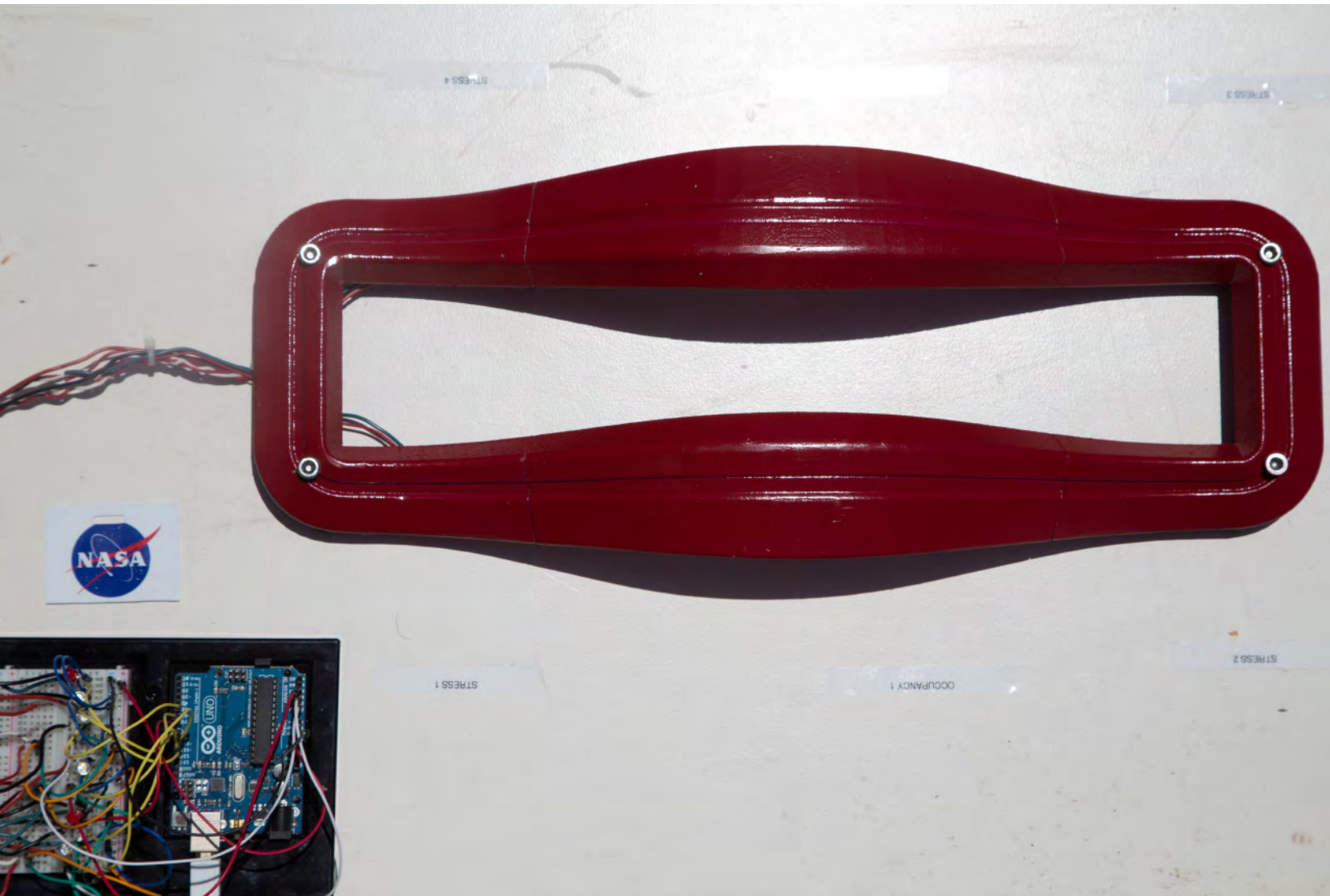

dissemination

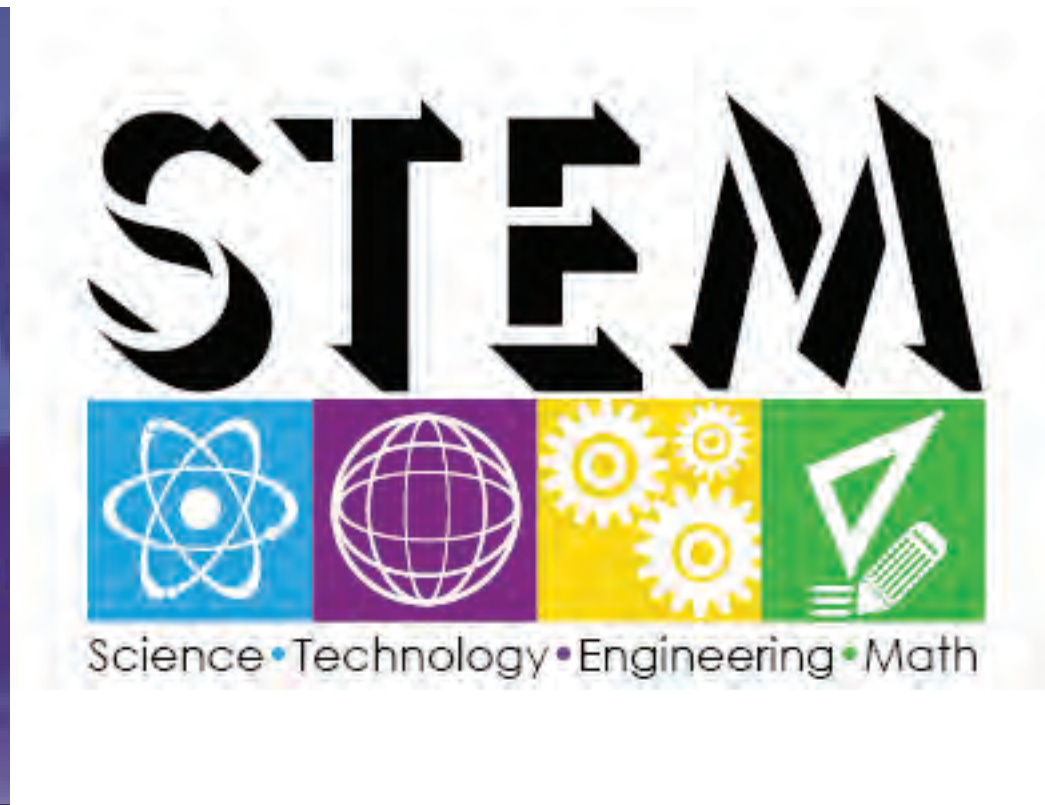
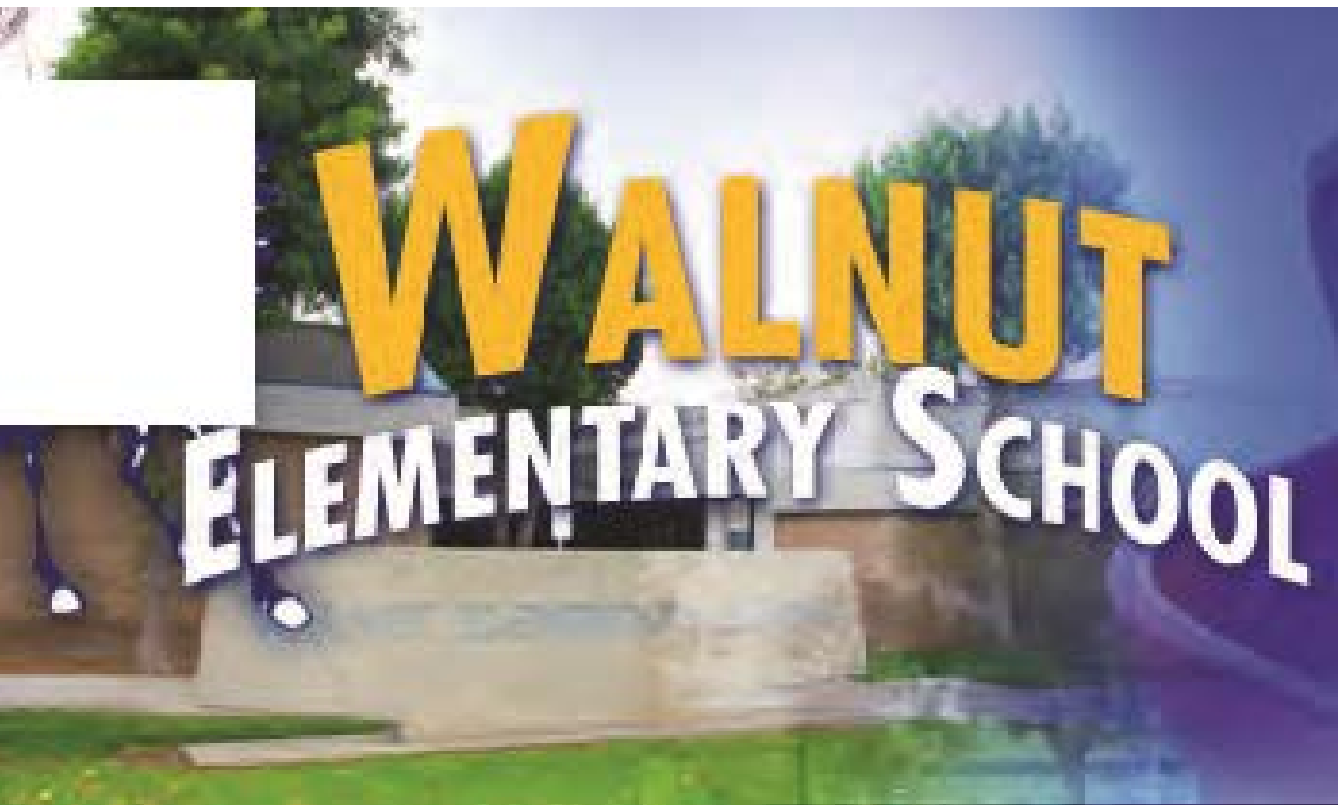

field trip to JSC



field trip to JSC





VORONOI
ALGORITHMIC
SPACE
TRANSPORT

PROF. MICHAEL FOX
MICHAELFOX@CSUPOMONA.EDU

X-HAB

XHAB
vertical habitability layout
+ fabrication studies

department of architecture
at california state polytechnic
university, pomona

