

Mars Sample Return (MSR) Capture, Containment, and Return System (CCRS) Overview

Huaizu You*, Bruno Sarli*, Kerry Gough*, Andria Hagedorn*, Paul Hudgins*, Calinda Yew*, Mark Neuman*, Justin Lin**, Tom Green**, Emily Bowman*, Julien Rondey*, Giuseppe Cataldo*, Brendan Feehan*

*NASA Goddard Space Flight Center

**Jet Propulsion Laboratory

2023 November 1

Taiwan International Assembly of
Space Science, Technology, and Industry
Taipei, Taiwan

The decision to implement Mars Sample Return will not be finalized until NASA's completion of the National Environmental Policy Act (NEPA) process. This document is being made available for information purposes only.

- MSR campaign overview
 - Motivation
 - Campaign elements
 - Program structure
 - Organizations geography
 - Architecture
 - Campaign timeline
 - Scenarios related to CCRS
- ERO-CCRS mission overview
 - ERO goal & objectives
 - ERO phases
 - CCRS goal & objectives
 - CCRS payload & ground
 - CCRS phases
 - CCRS operation scenarios
- Summary

Why MSR?



Mars Sample Return – Capture, Containment and Return System

Need:

NASA and ESA intend to return Martian samples safely to Earth for scientific research.

❖ Science:

- Understand our solar system history & evolution.
- Past & current habitability of Mars.

❖ Technology:

- Limitation of in-situ instruments.
- Proven capability to return planetary samples with robots.

Overall:

- Education & inspirational impacts to the public.

MSR Campaign Elements

Mars Sample Return Campaign

1

2

3

4



Sample Caching Rover (Mars 2020) Operations

- Sample acquisition/caching
- Sample delivery

Mars Sample Return Program



Sample Retrieval Lander (SRL)

- Orbiting Sample (OS)
- Sample Recovery Helicopters (SRH)
- Mars Launch System (MLS)
- Sampling Transfer Handling System (STHS)



Earth Return Orbiter (ERO)

- Capture, Containment, and Return System (CCRS)
- Earth Entry System (EES)



Sample Receiving Project (SRP)

- Sample Receiving Facility
- Curation
- Sample science investigations

MEP

MSR

MSR

MEP

Ground Element

(Mars Exploration Program)

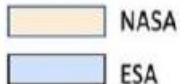

MSR Program Structure



Mars Sample Return – Capture, Containment and Return System

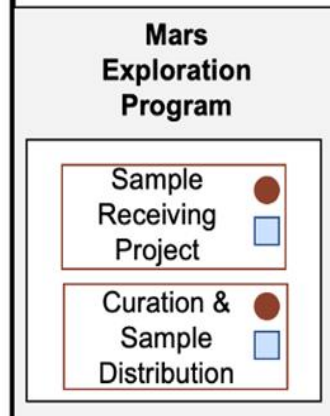
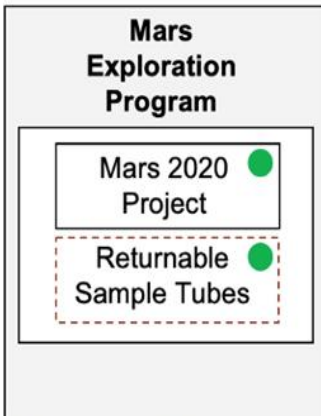
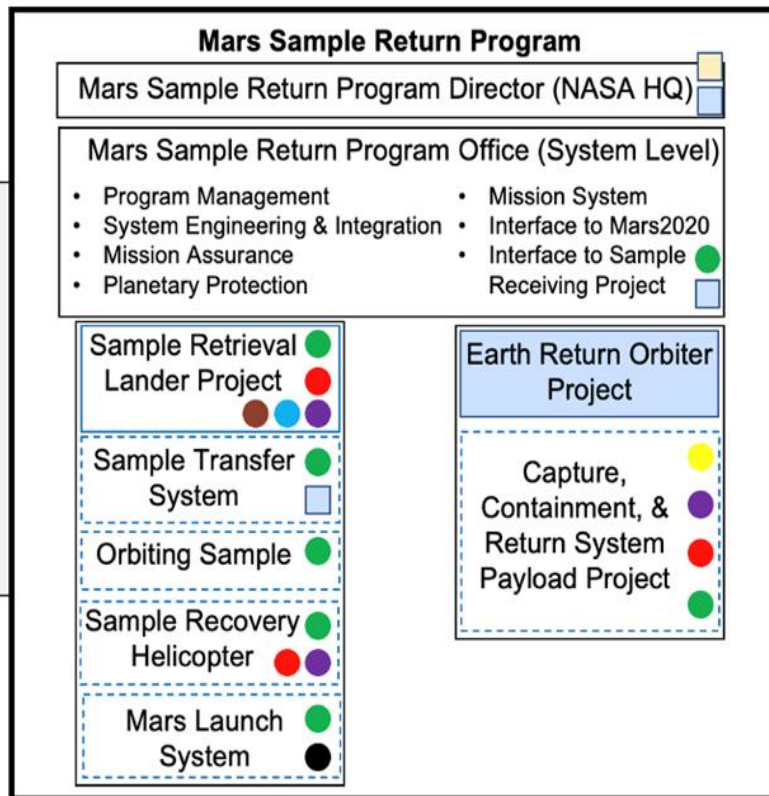

- NASA
- ESA
- ARC
- LaRC
- GSFC
- MSFC
- JPL
- KSC
- JSC

ARC= Ames Research Center,
 GSFC= Goddard Space Flight Center,
 JPL= Jet Propulsion Lab (Cal Tech),
 JSC= Johnson Space Flight Center,
 LaRC= Langley Research Center,
 ESA= European Space Agency
 KSC= Kennedy Space Center

ARC = Ames Research Center; **GSFC** = Goddard Space Flight Center; **JPL** = Jet Propulsion Laboratory; **JSC** = Johnson Space Center; **LaRC** = Langley Research Center; **MSFC** = Marshal Space Flight Center

MSR Organizations Geography



Mars Sample Return – Capture, Containment and Return System

- Joint endeavor: NASA & ESA
- International partners: Airbus, Lockheed Martin, etc.

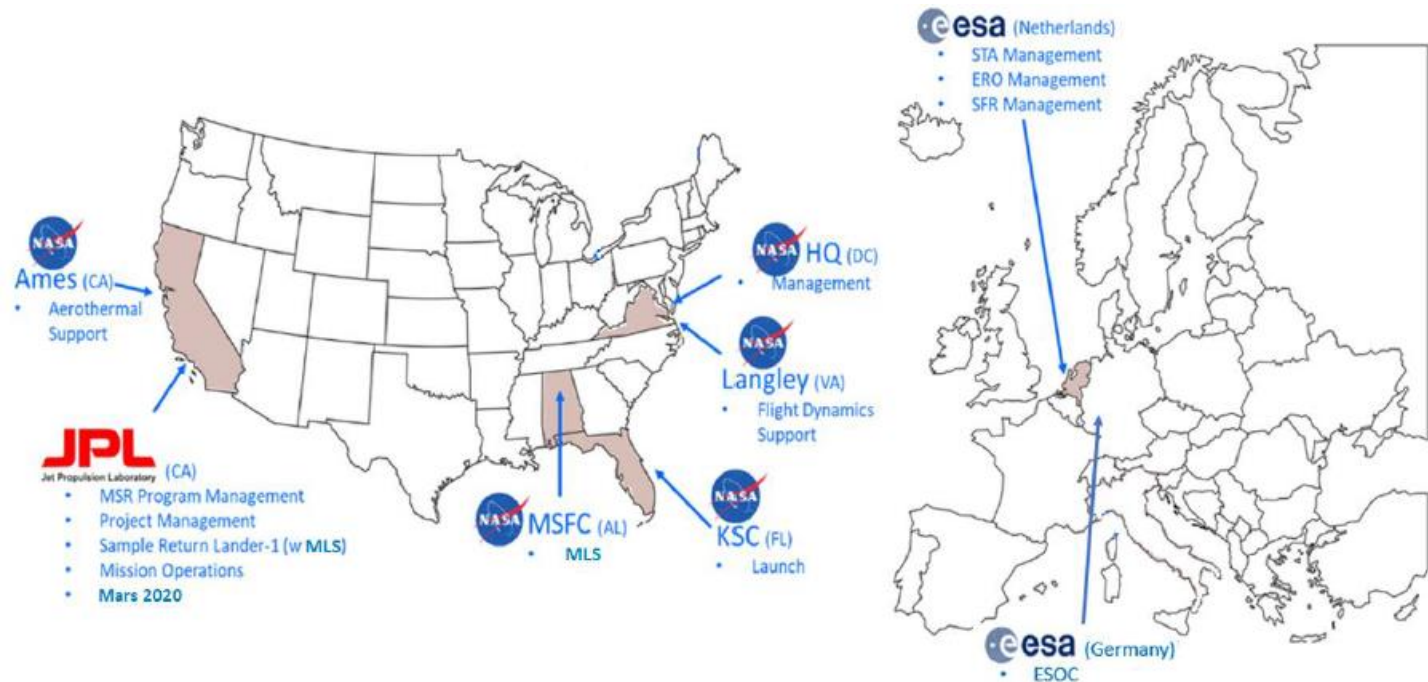

MSR Architecture Overview



Mars



28-27-33
(baseline)



Earth

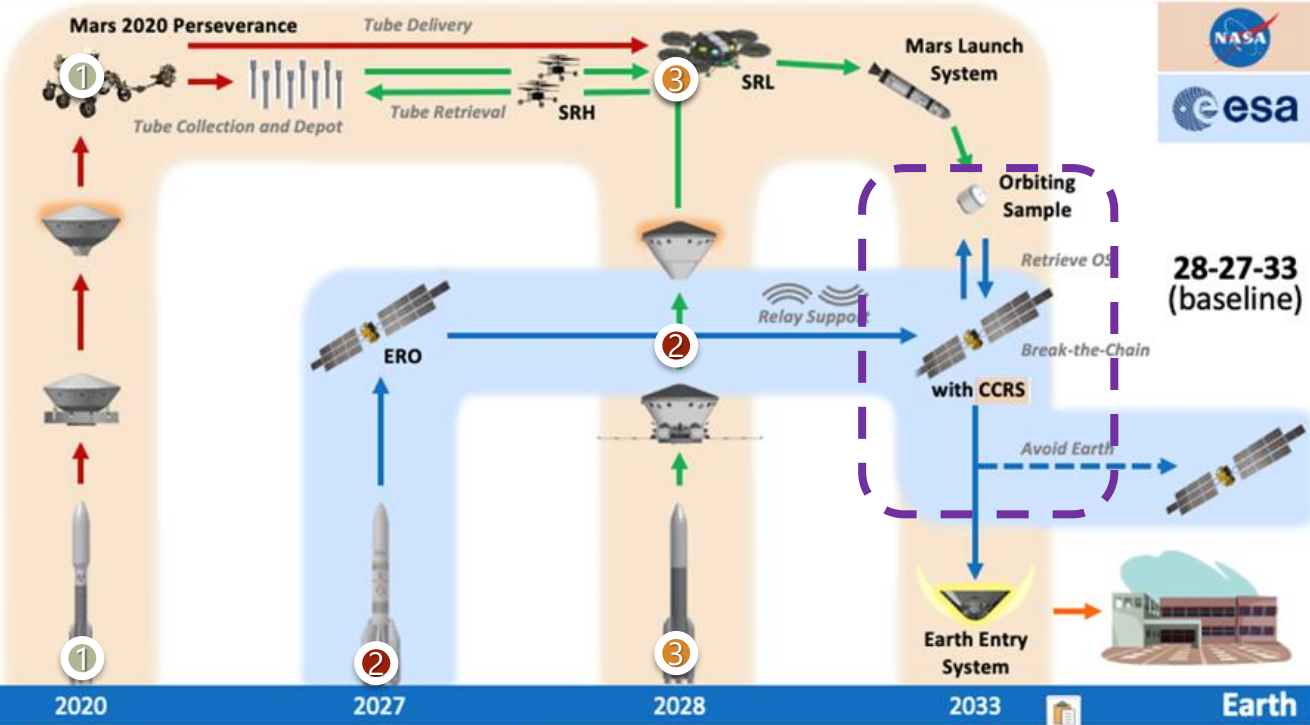

Mars 2020 (JPL)

Earth Return Orbiter (ERO) (ESA), with Capture, Containment, and Return System (CCRS) (GSFC)

Sample Retrieval Lander (SRL) (JPL), with Sample Recovery Helicopter(s) (SRH) (JPL) and Mars Ascent Vehicle (MAV) (MSFC)

Sample Receiving Project (SRP) (NASA/ESA)

MSR Campaign Timeline

28-27-33

- 2028 = SRL launch, 2027 = ERO launch, 2033 = Earth Return (nominal)
- Contingency return < 2035

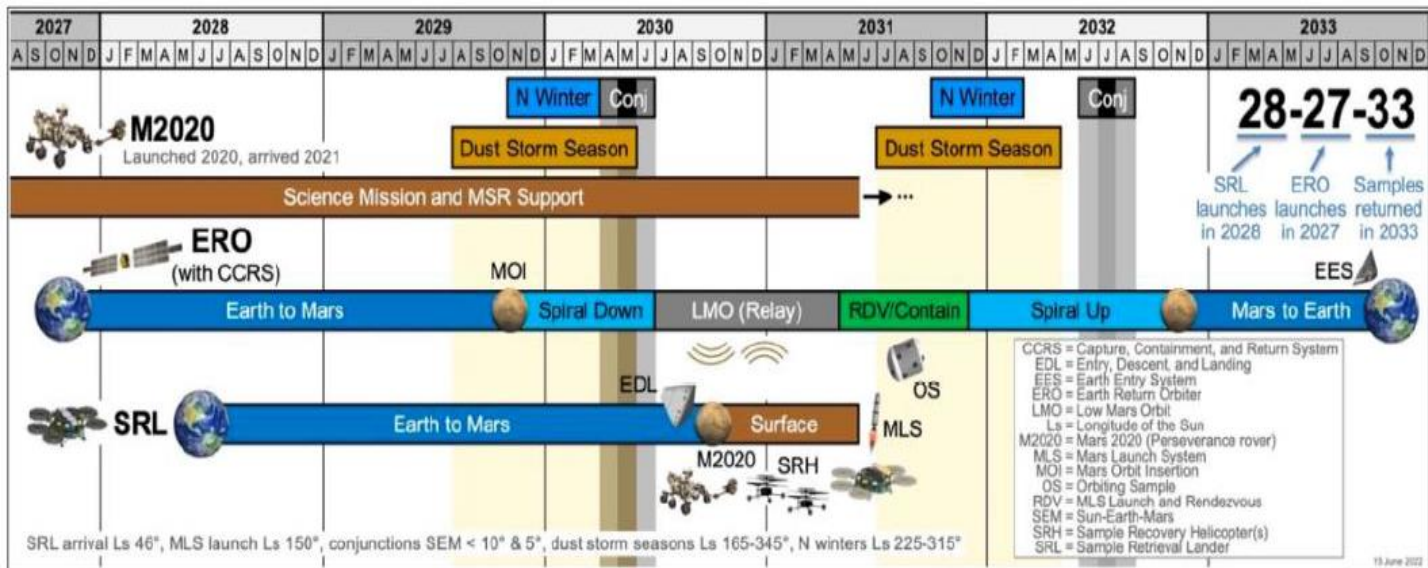

Rendezvous Mission Scenario

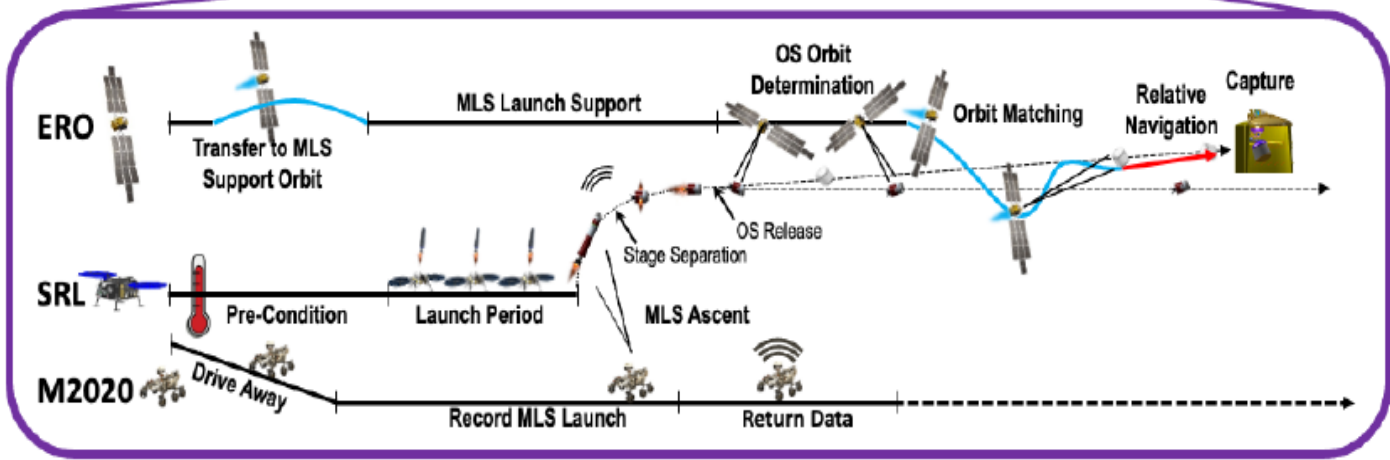
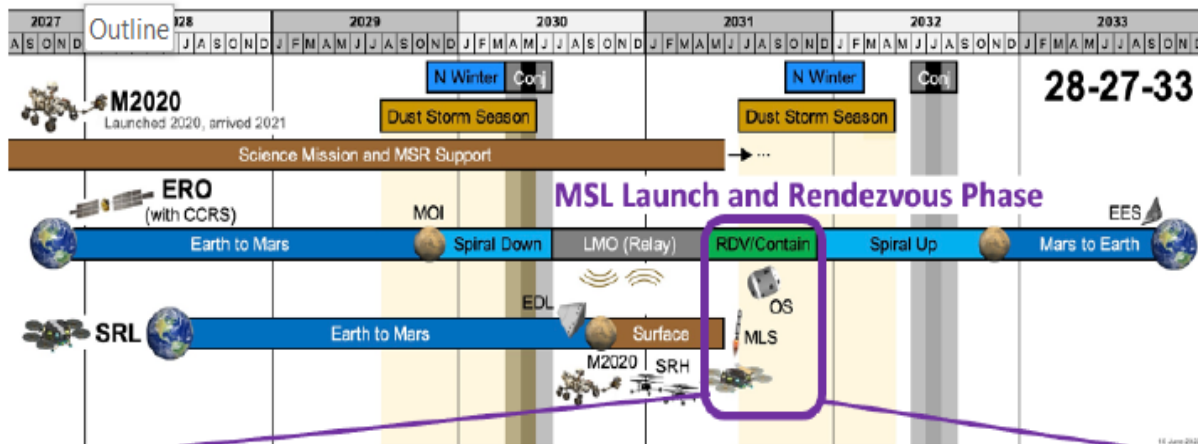

EES Delivery Mission Scenario

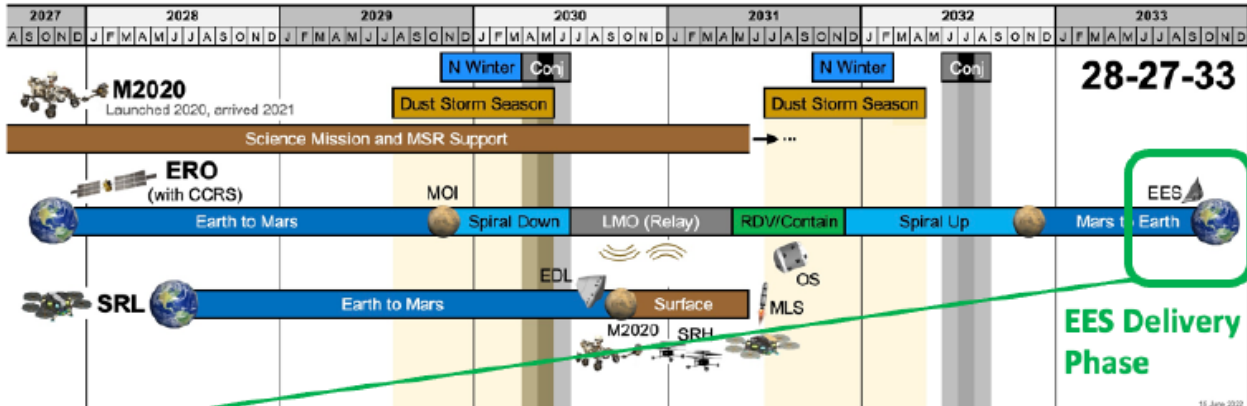

From Inbound Transfer Phase

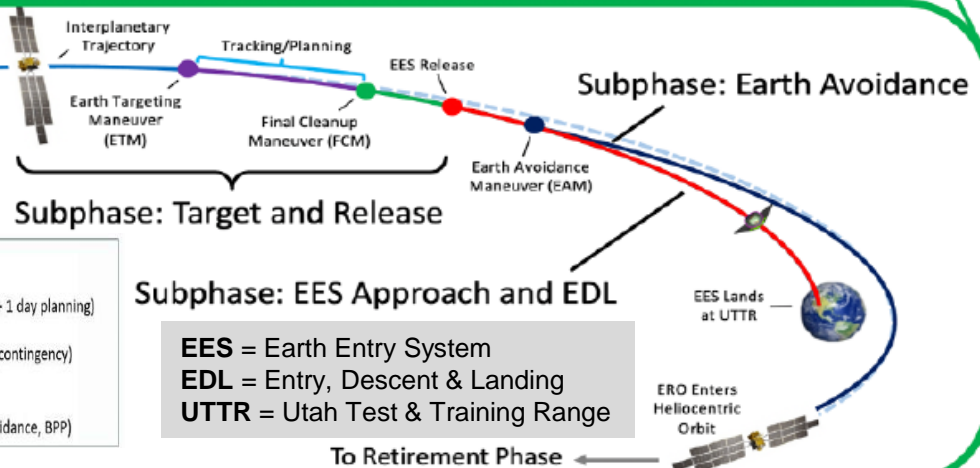

Timeline

- ETM Go/No-Go: 1 day before ETM
- ETM: ~3 days before FCM (2 days tracking + 1 day planning)
- FCM: 2 hours before release
- EES Release: Entry-3 days (nominal), up to -36 hr (contingency)
- EAM: EES Release + 1 hr
- EAMX: Entry - 31 hr
- ERO Disposal: Perigee + 4 days (long term Earth avoidance, BPP)

EES = Earth Entry System
EDL = Entry, Descent & Landing
UTTR = Utah Test & Training Range

ERO-CCRS Mission Overview

Goals:

- Capture the OS and bring it back to Earth
- Relay support for Mars assets

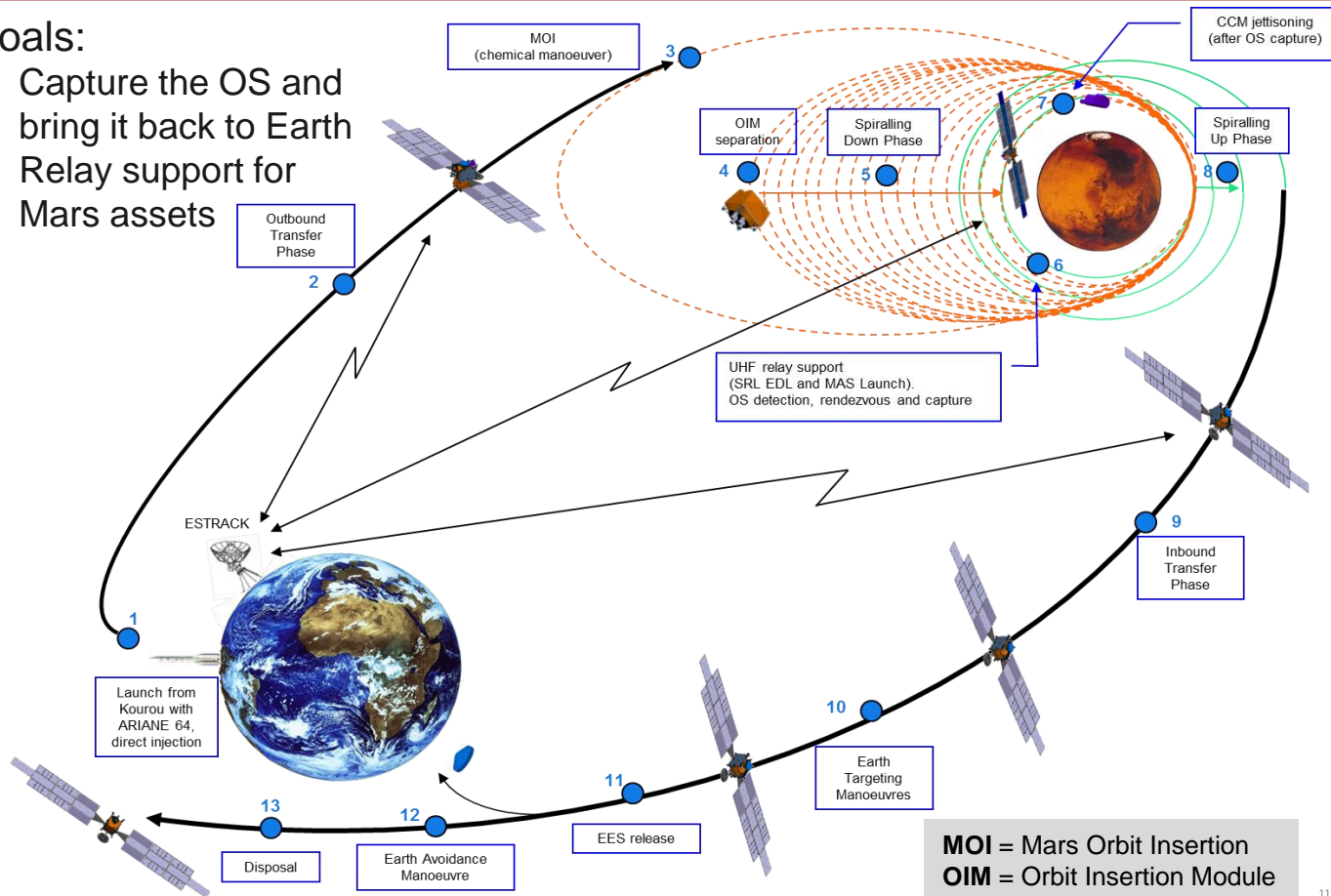

MOI = Mars Orbit Insertion
OIM = Orbit Insertion Module

ERO Objectives

1. Return the OS from Mars inside the EES.
2. Perform detection & rendezvous of the OS in the Mars orbit.
3. Provide surface communication relay at Mars.
4. Support CCRS during the transfer to Mars and at Mars.

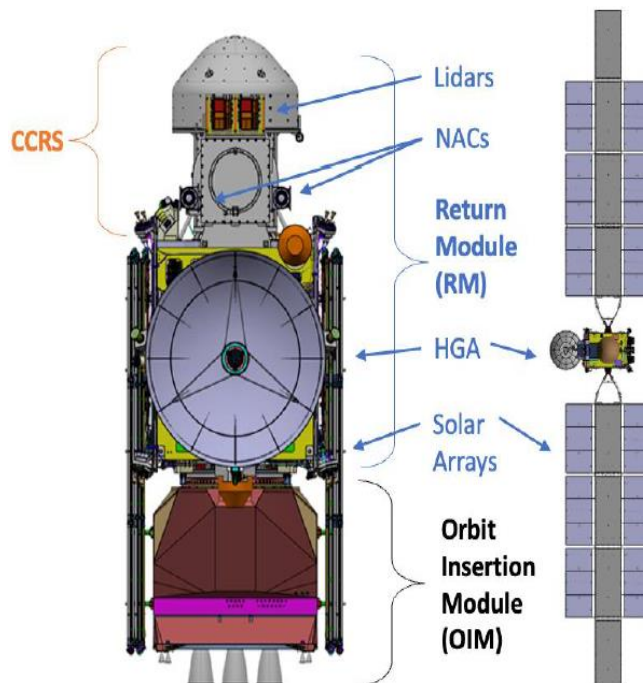

EES = Earth Entry System; OS = Orbiting Sample; NACs = Narrow Angle Cameras

ERO Phases

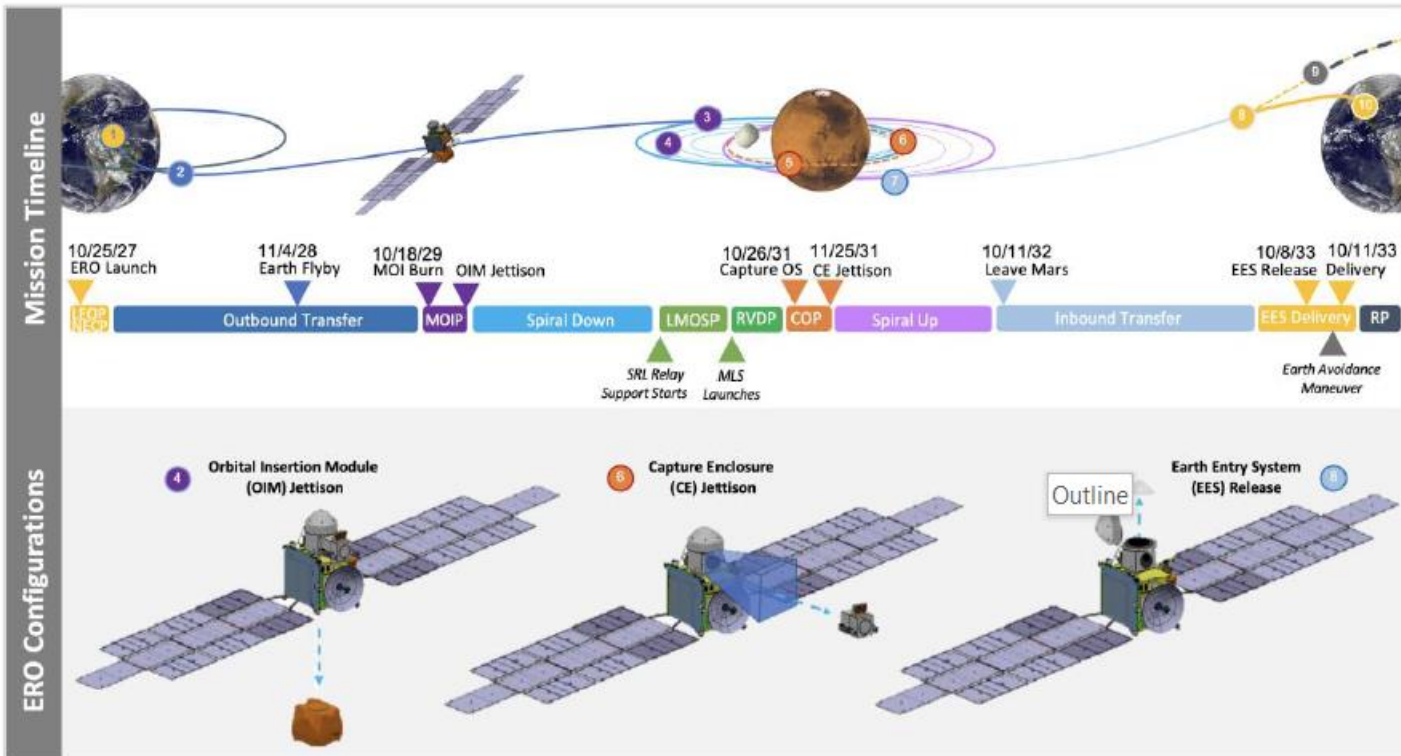

ERO Phase

Launch & Early Operations (LEOP)	Mars Orbit Insertion Phase (MOIP)	Rendezvous Phase (RVDP)	Inbound Transfer Phase (ITP)
Near Earth Commissioning Phase (NECP)	Spiral Down Phase (SDP)	Containment Phase (COP)	EES Delivery Phase (EDP)
Outbound Transfer Phase (OTP)	Low Mars Orbit Support Phase (LMOSP)	Spiral Up Phase (SUP)	Retirement Phase (RP)

CCRS Goal

CCRS Goal:
To bring back the Orbiting Sample from Mars orbit to Earth safely and aseptically.

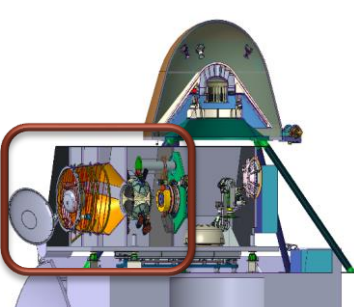

Capture & Config

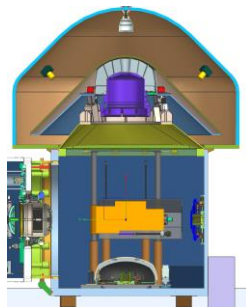

Earth Entry System (EES) Assembly

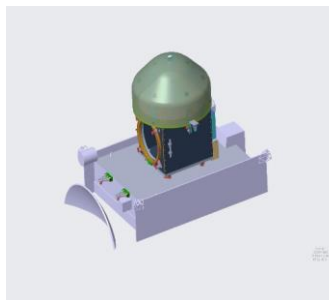

Containment Enclosure Jettison

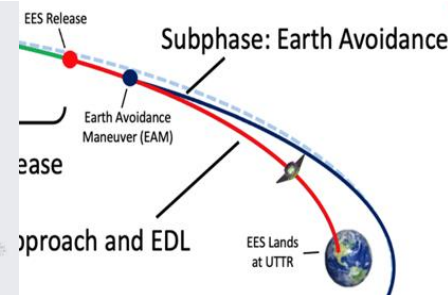

EES Release & Entry, Descent, Landing

CCRS Objectives



Mars Sample Return – Capture, Containment and Return System

- Perform overall robotic operation at Mars orbit in a cleanly and timely manner (all CCRS phases)
- Capture & Configure the OS (C&C phase)
- Perform On-Orbit Assembly of EES (EESOOA phase)
- Partial Jettison of CCRS to reduce mass for return and reduce contamination (PJR phase)
- Protect EES from meteorite collision and release the EES (PJR phase)
- Perform EES Approach, Entry, Descent and Landing on Earth (AEDL phase)
- Provide Ground and Operations support.

C&C = Capture & Configuration;
PJR = Protection, Jettison & Release;

EESOOA = EES On-Orbit Assembly;
AEDL = Approach, Entry, Descent and Landing

CCRS Payload Overview

Major system components of CCRS (interior, front view)

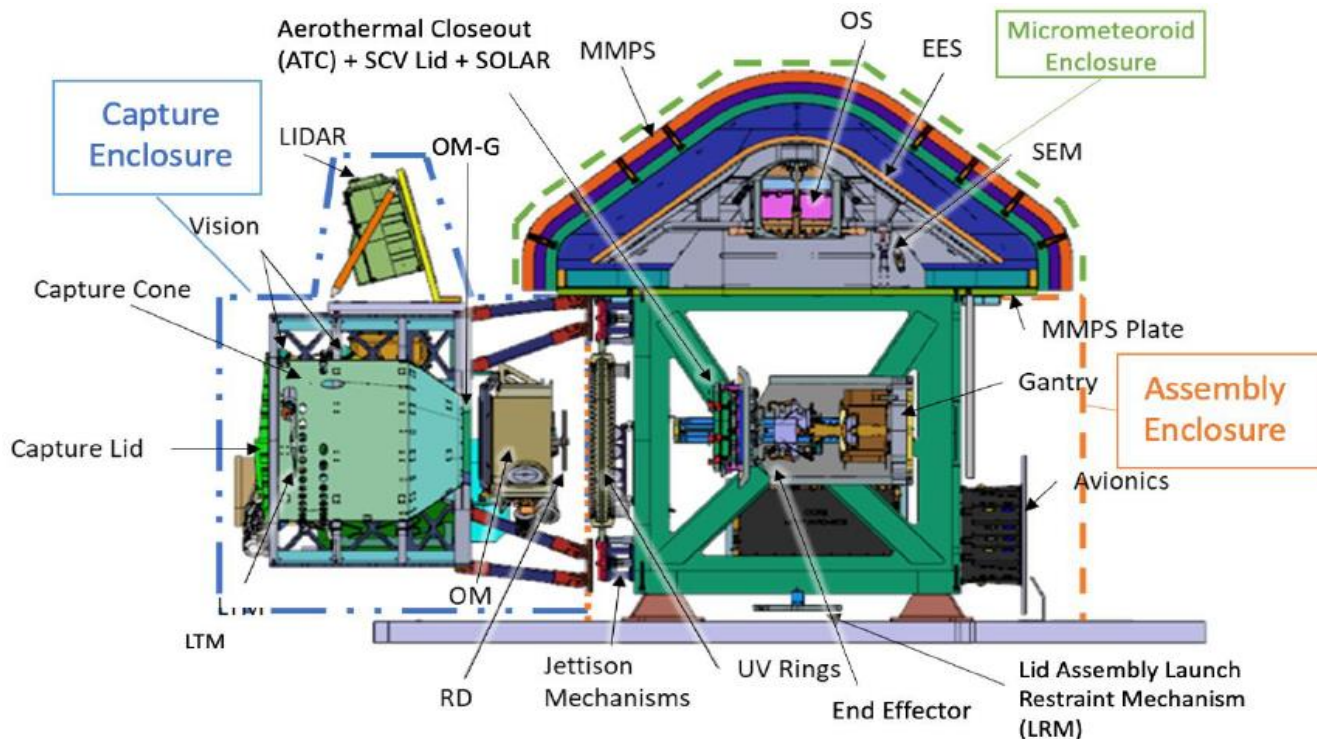

OM-G = Orientation Mechanism Guard; **RD** = Restraining Door; **SCV** = Secondary Containment Vessel
LTM = Linear Transfer Mechanism; **SEM** = Spin Eject Mechanism; **MMPS** = Micro-Meteorite Protection System

CCRS Payload Overview (cont'd)

Functions:

- Execute direct commands from ground.
- Process commands from stored command files.
- Perform fault management functions.
- Generate and transmit housekeeping and engineering telemetry and images to ERO.

High-Level Block Diagram:

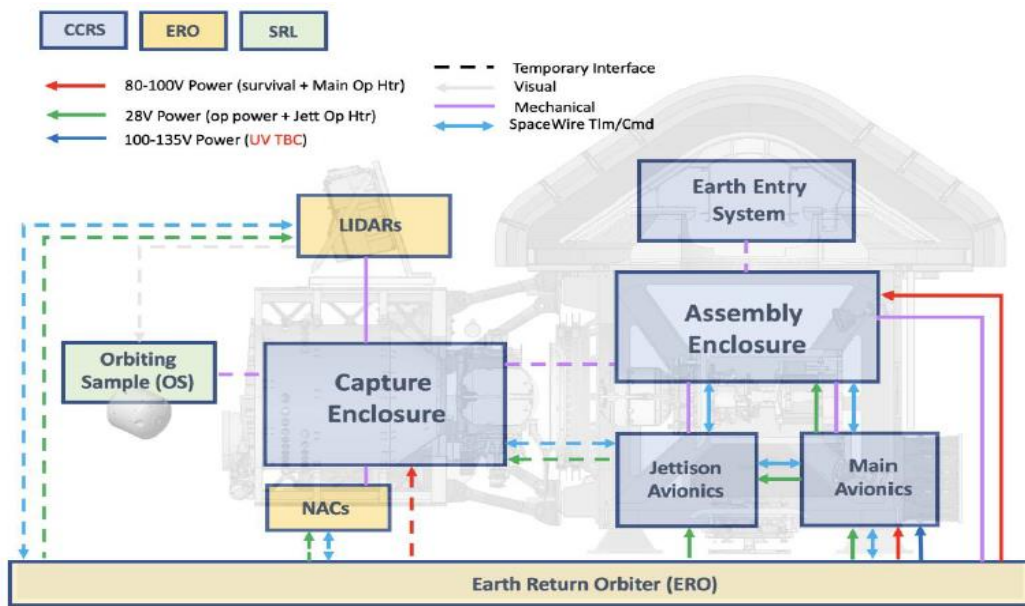

CCRS Ground Architecture



Mars Sample Return – Capture, Containment and Return System

Capture, Containment & Return System (CCRS)

Telemetry ↓
↑ Commands

Earth Return Orbiter (ERO)

Enroute to Mars:

- 2-hr daily contacts with Earth
- 8-hr weekly contacts with Earth

At Mars:

- ERO orbits Mars 12 times a day
- Each orbit has ~40 min contact with Earth

Freq: X-band

Antennas: HGA, MGA & LGAs

Max TLM Rates:

- 2.5 Mb/s near Earth
- 250 kb/s at Mars (2.2AU)

Light Time Delay: 4-21 min

Deep Space Network (DSN)



ESTRACK

Command & Telemetry ↑
↓

↑ Command & Telemetry
↓

ERO Mission Ops Center "MOC" (ESOC)

Telemetry ↓
↓ Planning Products

↑ CCRS Stored Commands

↑ Payload Ops Requests

↑ Voice

CCRS Payload Ops Center "POC" (GSFC)

↑ Remote Access

↑ Remote Access

↓ Products
↓ CMD
↑ TLM

↓ TLM
↑ Remote Access

NASA Laptops

Backup POC

Payload Systems Test Bed

MSR Program (JPL)

CCRS Phases

1. Launch, Commissioning & Outbound Transfer (LCOT)
2. Capture & Configuration (C&C)
3. EES On-Orbit Assembly (EESOOA)
4. Protection, Jettison & Release (PJR)
5. Approach, Entry, Descent & Landing (AEDL)

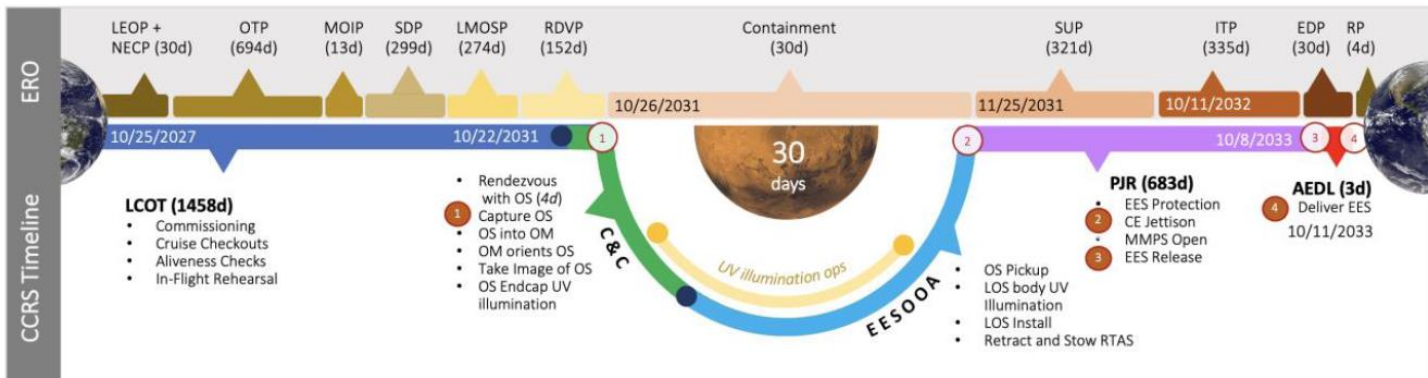

LCOT Phase



Mars Sample Return – Capture, Containment and Return System

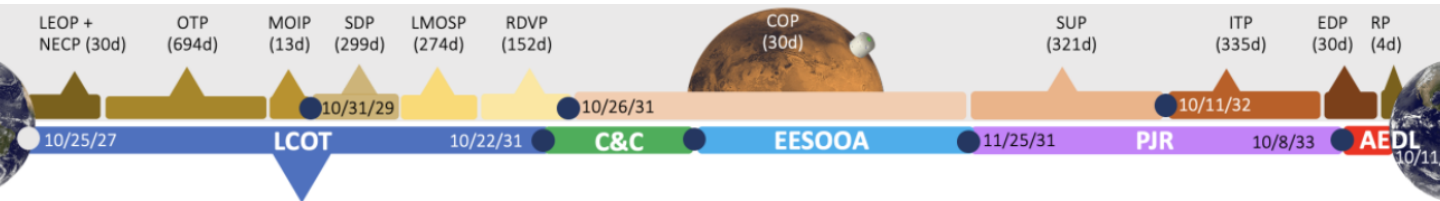

Campaign Phase				MLS Launch and Rendezvous		
ERO Phase	Pre-Launch	LEOP	NECP	OTP, MOIP, SDP, LMOSP		LMOSP
CCRS Phase	Launch, Commissioning & Outbound Transfer (1458 d)					
CCRS Subphase	Pre-Launch	Launch	Commissioning	Cruise Alive	Cruise Checkout	In-Flight Rehearsal
Timeframe	TBD to L - 3 hr	L-3 hr to L+7 days	L+7 days to L+30 days	Every 4 months	Once a year	Once during ERO Relay Operations
Key Functions	<ul style="list-style-type: none"> Aliveness tests of CCRS components on launch Pad Confirm ready to launch 	<ul style="list-style-type: none"> Survive Launch No CCRS Commanding 	<ul style="list-style-type: none"> Release Launch Locks* ROM on reversible actuators Full functional checkout of system 	<ul style="list-style-type: none"> Temperature & sensor polling 	<ul style="list-style-type: none"> Small Actuator Moves 	<ul style="list-style-type: none"> ROM on reversible actuators Flight Calibrations
Entry Criteria	ERO arrives at the Launch Site	S/C is configured to Internal Power	ERO is complete with mission critical activities.	ERO not busy	ERO not busy	ERO not busy
Exit Criteria	S/C is configured to Internal Power	ERO is complete with mission critical activities	Ground confirms system functionality post launch	Ground confirms CCRS Health & Safety	Ground confirms Mechanism functionality	Ground confirms system functionality and powers CCRS OFF until arrival at HIP

C&C Phase



Mars Sample Return – Capture, Containment and Return System

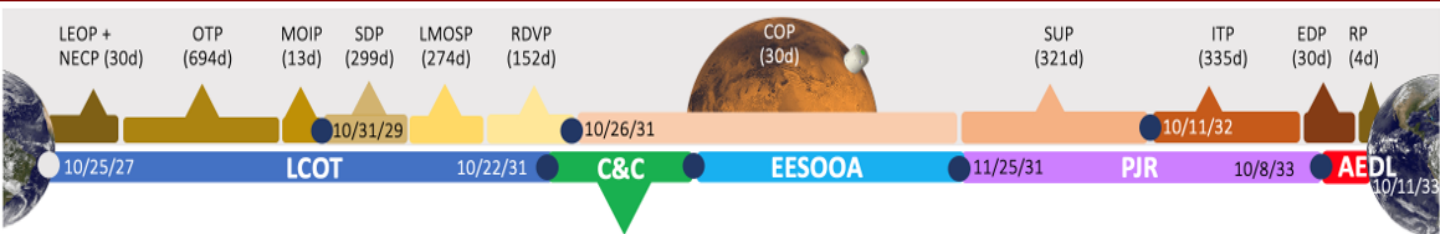

Campaign	MLS Launch and Rendezvous		Containment			
ERO Phase	RDVP		Containment (COP)			
CCRS Phase	Capture & Configuration					
CCRS Subphase	Pre-Capture	Capture	Funnelling	Orientation	Inspection	Endcap Illumination
Duration	about 2.5 days* + 8 hrs ground reviews	40 min + 4 hrs ground review	186 min	8 hrs	3.5 min + 4 hrs ground review	UV step #1 = ~30hours + ground review
Key Functions	<ol style="list-style-type: none"> 1. Open capture lid 2. LTM capture operation checkout 3. Power ON CSS & Capture Sensor Calibration 	<ol style="list-style-type: none"> 1. OS triggers sensor arrays, actuation of LTM swing arm & lid 2. LTM arm fully deployed* (OS Captured) 3. Capture Lid Closed* 	<ol style="list-style-type: none"> 1. LTM funnels OS thru the capture cone; stops at OM bulkhead 	<ol style="list-style-type: none"> 1. OM grasps OS and manipulated into correct orientation 2. Move LTM to Beginning of Travel 3. Pre-load OS against OM-G 	<ol style="list-style-type: none"> 1. Take image of OS end-cap 2. OS constrained in OM with RD closed 3. Pre-Load OM against OM-G with OM-RD 4. Power OFF CSE 	<ol style="list-style-type: none"> 1. Open OM-RD 2. Power on UV System 3. UV Illumination Step #1 (Ring-1) of Endcap
Entry Criteria	ERO is at HIP	Previous exit criteria	Previous exit criteria	Previous exit criteria	Previous exit criteria	Previous exit criteria
Exit Criteria	Ground "Go" for capture at SK4	Ground confirms OS is within capture cone	LTM reaches end of travel with OS within OM	OM-G is rotated clear	Ground verifies OS orientation via images	Ground verifies OS End-Cap has completed it's UV Illumination

EESOOA Phase



Mars Sample Return – Capture, Containment and Return System

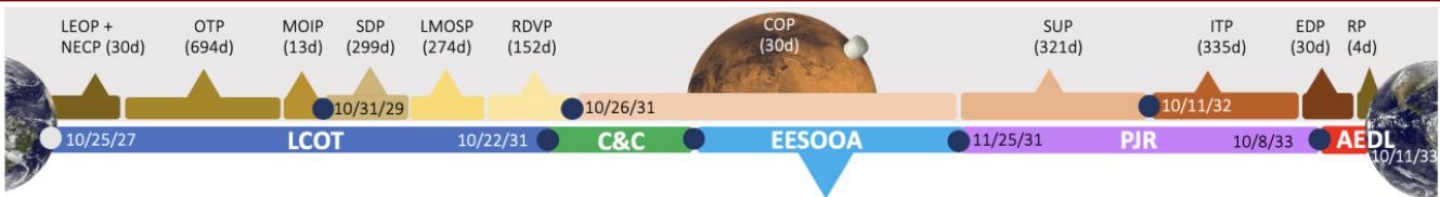

ERO Phase	Containment (COP)		
CCRS Phase	EES On-Orbit Assembly		
CCRS Subphase	OS Pickup	UV Illumination	LOS Install
Duration	2.5 hours + 3 GITL	Non-thrusting time: ~178 hours Thrusting Allowed: TBD duration for 12 GITL	2.5 hours + 3 GITL
Key Functions	<ol style="list-style-type: none"> 1. Initialize RTS/PIE 2. Extend RTS Gantry towards OS in OM 3. Latch SOLAR to OS * (irreversible) 4. Retract OM Paddles 5. Retract RTS Gantry with LOS 	<ol style="list-style-type: none"> 1. UV Illumination Step #2 - 13 2. Power off UV System 	<ol style="list-style-type: none"> 1. Position LOS For Installation 2. Angularly & Axially Align LOS to EESA 3. Assemble EESA into Landing Config* 4. Retract and Stow RTAS
Entry Criteria	OS Endcap has completed UV illumination	Previous Exit Criteria	Previous Exit Criteria
Exit Criteria	EE is in Full Grip	Ground confirms UV illumination of LOS body is complete, Gantry is in final position	Ground confirms successful assembly of EES aeroshell into landing configuration, with RTAS stowed

PJR Phase



Mars Sample Return – Capture, Containment and Return System



MSR Phase	Containment		N/A	EES Delivery	
ERO Phase	COP		SUP	ITP	EDP
CCRS Phase	Protection, Jettison & Release (683 days)				
CCRS Subphase	Jettison		Transit	EES Release	
Duration	< 20 msec for cable cutters actuation < 20 msec for separation system actuation Plus time waiting for ground confirmation of telemetry		678 days	From uplink cmds - release (5 days) Note: EES ejection duration (min-max): 0.242 - 0.312 seconds (ERO-CCRS-IRD-70) Plus time waiting for ground confirmation of telemetry	
Key Functions	<ol style="list-style-type: none"> Cut Cables connection between both (CE and AE) and (RSS and ERO) Separate CE from AE Kick CE off AE/ERO 		<ol style="list-style-type: none"> Provide protection against MMOD CCRS Aliveness Checks during SUP & ITP 	<ol style="list-style-type: none"> Open MMPS Lid Provide ejection capability to release EES from ERO/CCRS 	
Entry Criteria	Telemetry confirms successful installation of SCV in EES aeroshell		Previous Exit Criteria	Previous Exit Criteria	
Exit Criteria	Telemetry confirms successful separation of CE from ERO/AE		ERO reaches planned ETM location	EES released from ERO	

AEDL Phase



Mars Sample Return – Capture, Containment and Return System

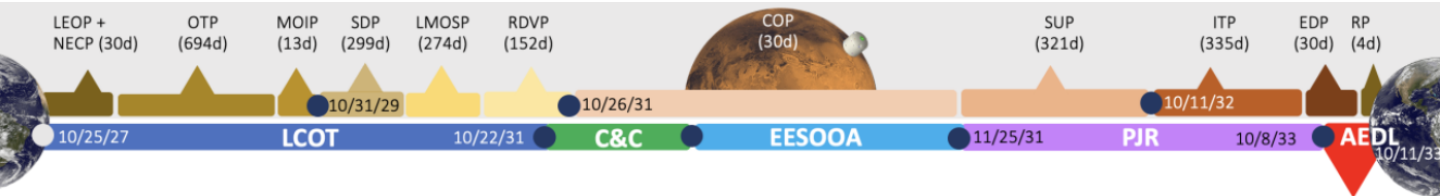

Program Phase	EES Delivery
ERO Phase	EDP
CCRS Phase	Earth Approach, Entry, Descent & Landing (3 days)
CCRS Subphase	Approach & EDL Subphases
Duration	3 days
Key Functions	Deliver EES on free-flight through space until atmospheric entry and landing at the landing site
Entry Criteria	Immediately after EES release
Exit Criteria	EES lands at the landing site

CCRS Critical Events



Mars Sample Return – Capture, Containment and Return System

Event	CCRS Mission Critical	CCRS Time Critical	Not-Reversible	ERO Critical Phase	ERO Safety Critical	ERO Cameras Monitoring	MSR Key Event	MSR Decision Point	CCRS Phase
Launch Lock Releases			<input checked="" type="checkbox"/>						LCOT
OS Capture	<input checked="" type="checkbox"/>			<input checked="" type="checkbox"/>			<input checked="" type="checkbox"/>		C&C
Deploy LTM	<input checked="" type="checkbox"/>	<input checked="" type="checkbox"/>		<input checked="" type="checkbox"/>					C&C
Close Capture Lid	<input checked="" type="checkbox"/> *	<input checked="" type="checkbox"/> *							C&C
Complete OS base illumination	<input checked="" type="checkbox"/>								C&C
Latch OS to Integrated Lid	<input checked="" type="checkbox"/>		<input checked="" type="checkbox"/>						EESOOA
Complete OS body illumination	<input checked="" type="checkbox"/>								EESOOA
LOS Radially Aligned to EES Aeroshell	<input checked="" type="checkbox"/>		<input checked="" type="checkbox"/>						EESOOA
SCV Latch hardstop Engaged (EESA Closeout)	<input checked="" type="checkbox"/>		<input checked="" type="checkbox"/>						EESOOA
Sever Cables Between CE & AE			<input checked="" type="checkbox"/>						PJR
Jettison Capture Enclosure (CE)			<input checked="" type="checkbox"/>			<input checked="" type="checkbox"/>			PJR
Open MMPS Lid	<input checked="" type="checkbox"/>		<input checked="" type="checkbox"/>			<input checked="" type="checkbox"/>			PJR
Release EES	<input checked="" type="checkbox"/>	<input checked="" type="checkbox"/>	<input checked="" type="checkbox"/>		<input checked="" type="checkbox"/>	<input checked="" type="checkbox"/>	<input checked="" type="checkbox"/>	<input checked="" type="checkbox"/>	PJR

Red box (Containment timeline allocation) = 30 days (720 hrs)

- Starts after confirmation of full LTM deployment and ends with closeout of the fully assembled EES and jettison.
- 50-50 allocation between CCRS (360 hrs) & ERO (360 hrs).

CE = Capture Enclosure; AE = Assembly Enclosure; OS = Orbiting Sample
LTM = Linear Transfer Mechanism; SCV = Secondary Containment Vessel

Operational Scenarios – LCOT phase

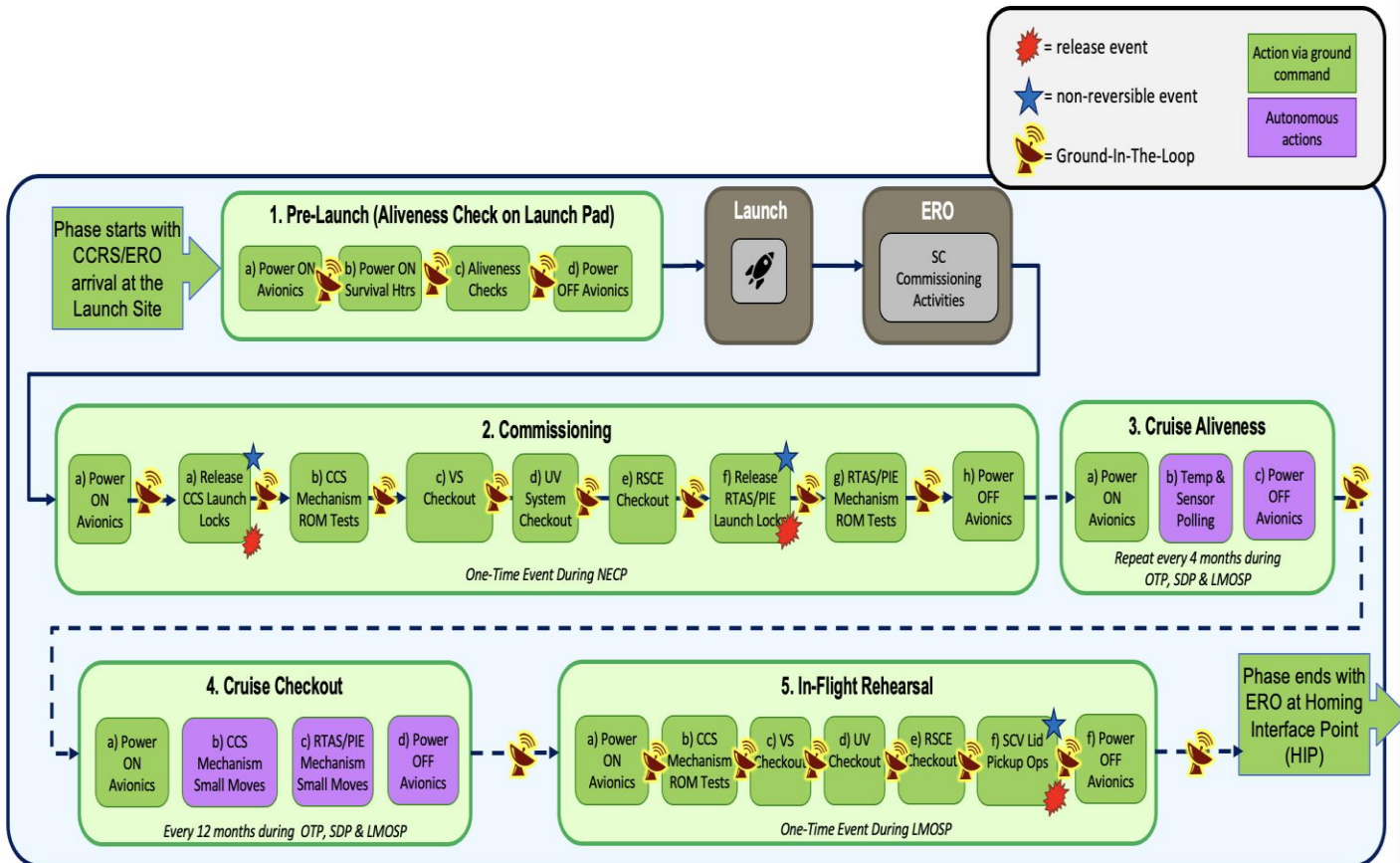

Operational Scenarios – In Flight Rehearsal

= release event	RTA Gantry	OM Restraining Door
= non-reversible event	RTA End Effector	OM Orientation Paddles
= Ground-In-The-Loop (GITL)	SCV Rotary Latch	Lid Restraint Mechanism
	Lid Restraint Mechanism	UV System

In-Flight Rehearsal

Subphase begins with CCRS Ops Team Ready

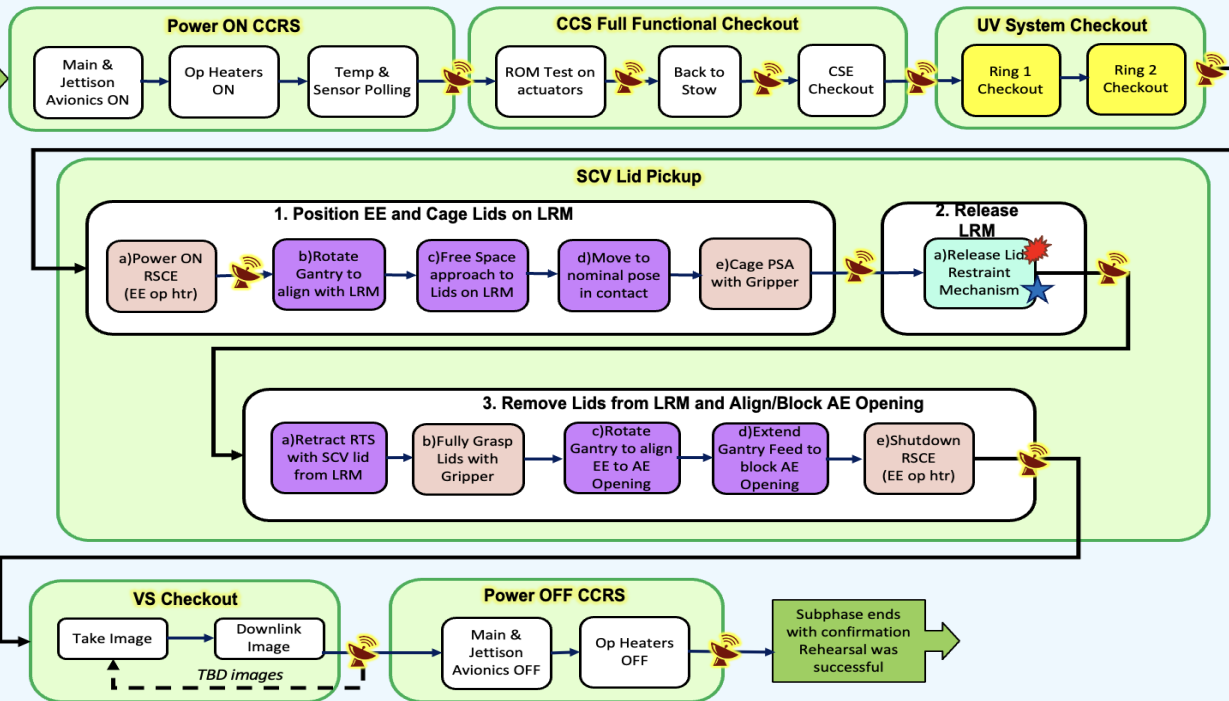

Operational Scenarios – C&C phase

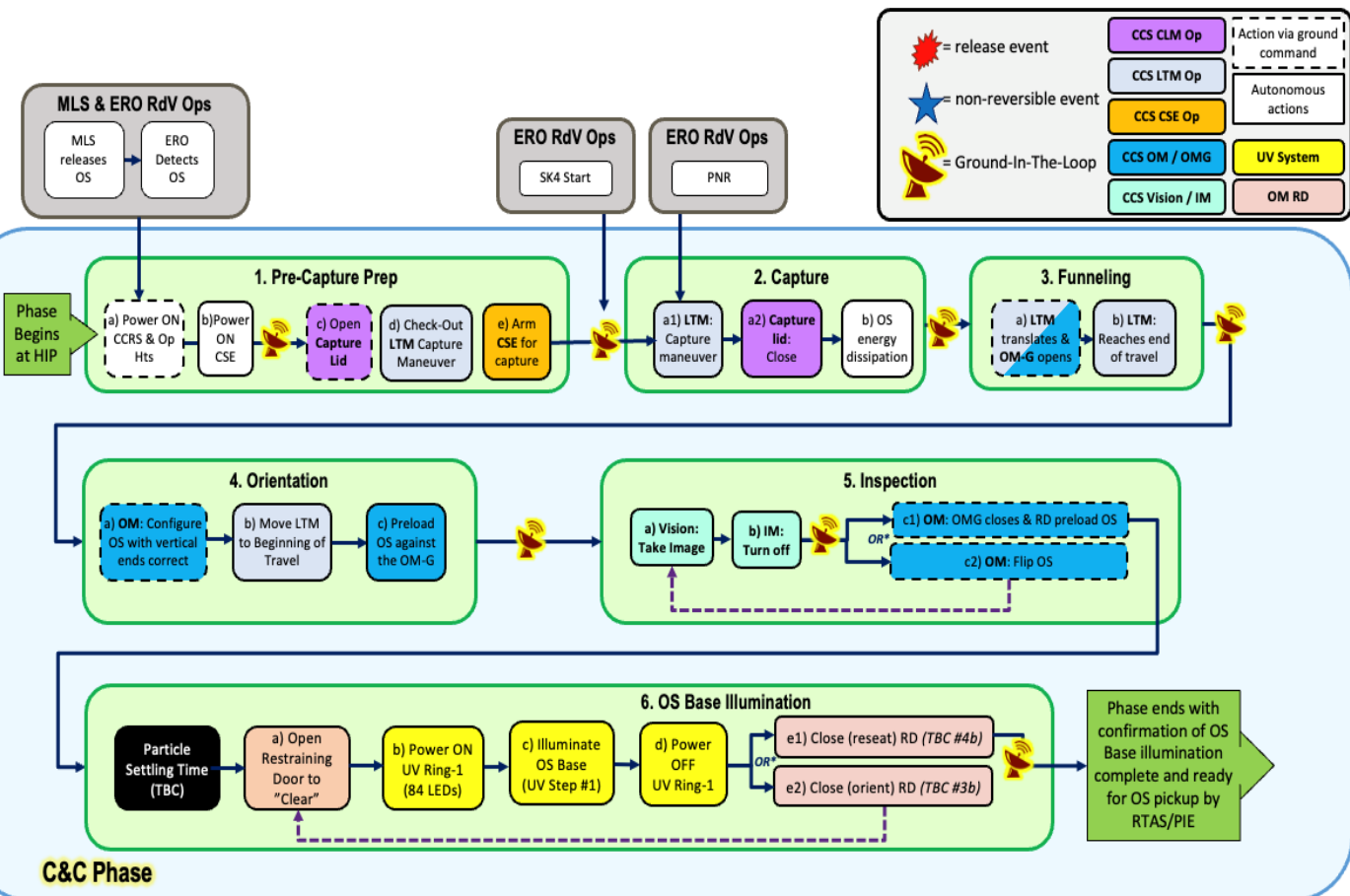

Operational Scenarios – EESOOA phase



Mars Sample Return – Capture, Containment and Return System

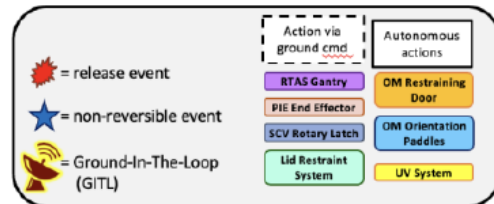

EESOOA Phase

Phase starts with confirmation of endcap illumination complete and ready for OS pickup by RTAS/PIE

1. OS Pickup

1. Power ON RSCE

a) Initialize RTAS/PIE (EE op htr)

2. Latch SOLAR to OS

a) Extend Gantry towards OS

b) Latch SOLAR (OS Docking)

3. Retract LOS to Standoff

a) Retract OM Paddles

b) Retract Gantry with LOS

c) Fully grasp LOS with Gripper

2. UV Illumination

a) Power ON UV Ring-2 (42 LEDs)

b) Illuminate LOS (UV Step)

c) Power OFF UV Ring-2

b) Gantry reaches final pose

d) Retract Gantry with LOS

Move LOS through UV Ring-2 (UV Steps #2 – 13)

3. LOS Install

1. Position LOS For Installation

a) Rotate to Align LOS with EES

b) Free Space Approach to EESA

c) Insert LOS into SCV in EESA

2. Align LOS to EESA

a) Relax EE Grasp to cage LOS

3. Assemble EESA into Landing Configuration

a) Gripper Fully Opens

b) Torquer rotates interface to LOS to engage SCV rotary latch mechanism hard stop

4. Retract and Stow RTA

a) Unwind Torquer into RIP clearances

b) Retract to free space

c) Return Torquer to starting orientation

d) Retract to stow feed

e) Rotate to stow rotary stage

Phase ends with LOS Latched into EES Aeroshell, with RTAS stowed

Operational Scenarios – PJR phase



Mars Sample Return – Capture, Containment and Return System

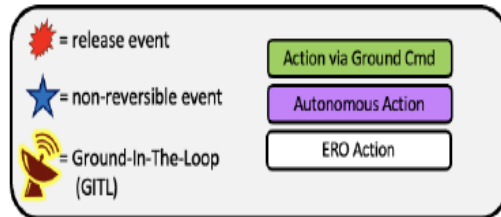

Jettison, Protection & Release Phase

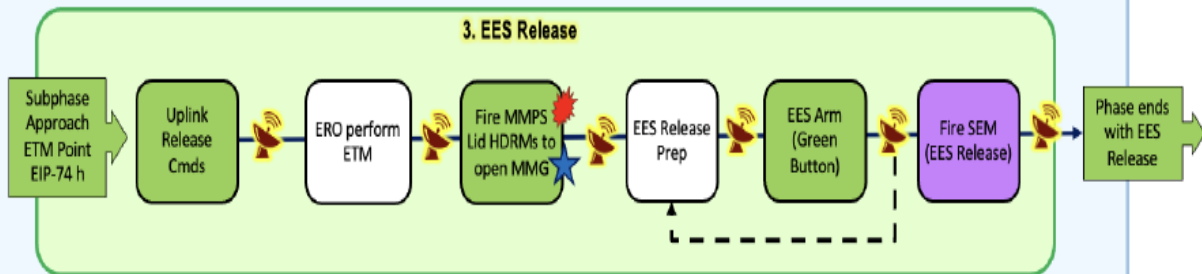
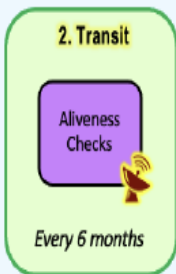
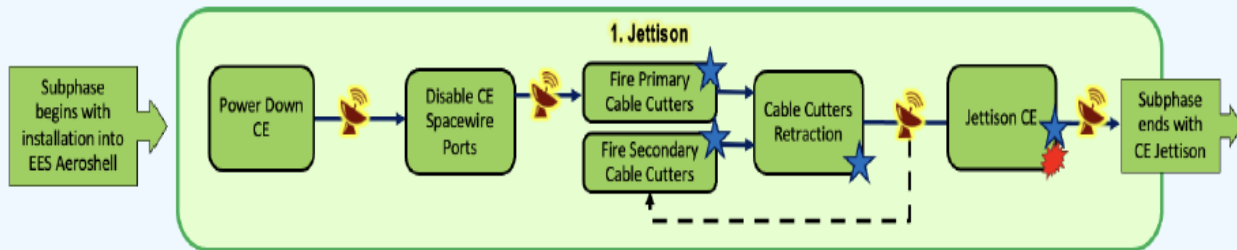

Operational Scenarios – AEDL phase



Mars Sample Return – Capture, Containment and Return System

Values are approximate

Not to scale

Gray items not in AEDL Phase (reference only)

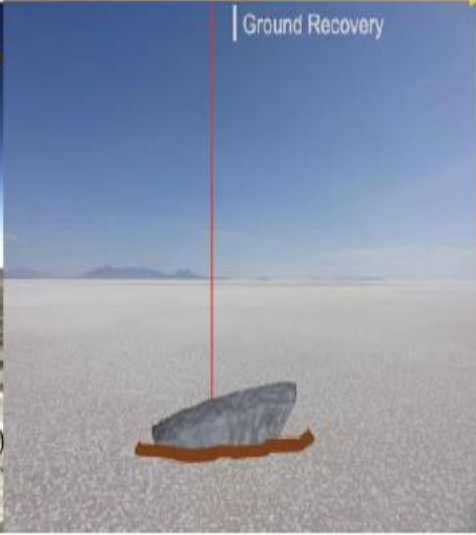
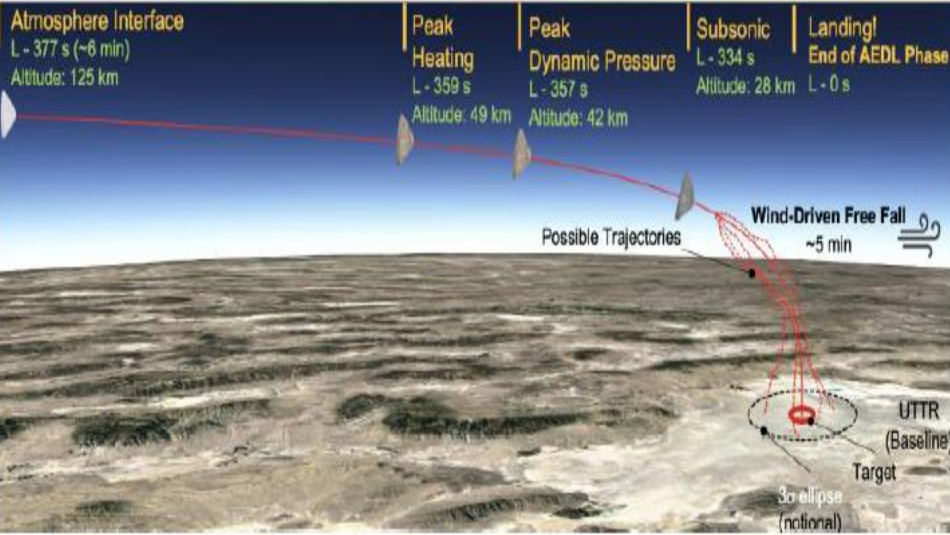

Summary



- With ERO, CCRS would have many firsts
 - Orbital rendezvous and capture in Mars orbit
 - In-space sterilization and containment
 - On-orbit spacecraft (EES) assembly at Mars
 - Precise and fully passive entry, descent, and landing
- NASA is taking a “safety first” approach to MSR safety engineering and sample handling
 - Consistent with Category V / restricted Earth return requirements