

Deployable Greenhouse for food production on long-duration exploration missions

Final Design Review

School of Mechanical & Aerospace Engineering
School of Biosystems & Agricultural Engineering
School of Architecture
Oklahoma State University



**Oklahoma State University Space
Cowboys Research Team**



AGENDA

- Team Overview
- Review Space Rated Design
- Analogs and Models
 - Full Scale Analog
 - Deployable Analog
 - Architectural Model
- Outreach Update

THE TEAM



TEAM BREAKDOWN



- **OSU X-Hab Team**

- Mechanical & Aerospace Engineering
- Biosystems & Agricultural Engineering
- Architecture & Architectural Engineering
- Electrical & Computer Engineering



- Aerospace Engineering
- Electrical and Computer Engineering
- Biosystems & Agricultural Engineering
- Architectural Engineering

GEOFF KIBBLE



Space Rated Design

CAD

LAUNCH SYSTEM



- NASA Space Launch System
 - In development
 - 100-130t payload lift capabilities
 - Payload max diameter of 4.6m
 - Payload max height 19.1m
 - Capable of putting payload into LEO

SLS Platform

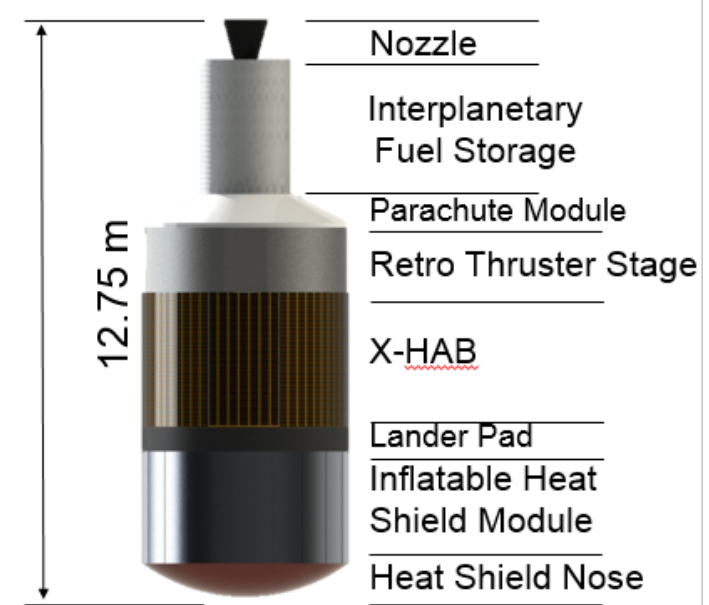
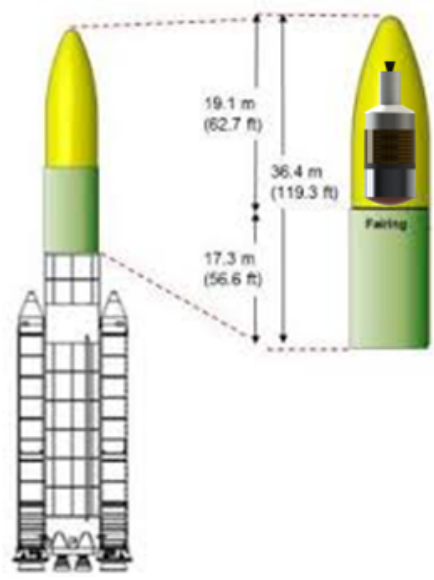

Total mass: < 100,000 kg



INTERPLANETARY TRANSIT

- Delta V burn from a standard Hohmann transfer maneuverer
 - Rendezvous trajectory to Mars
- 8-9 months transfer time

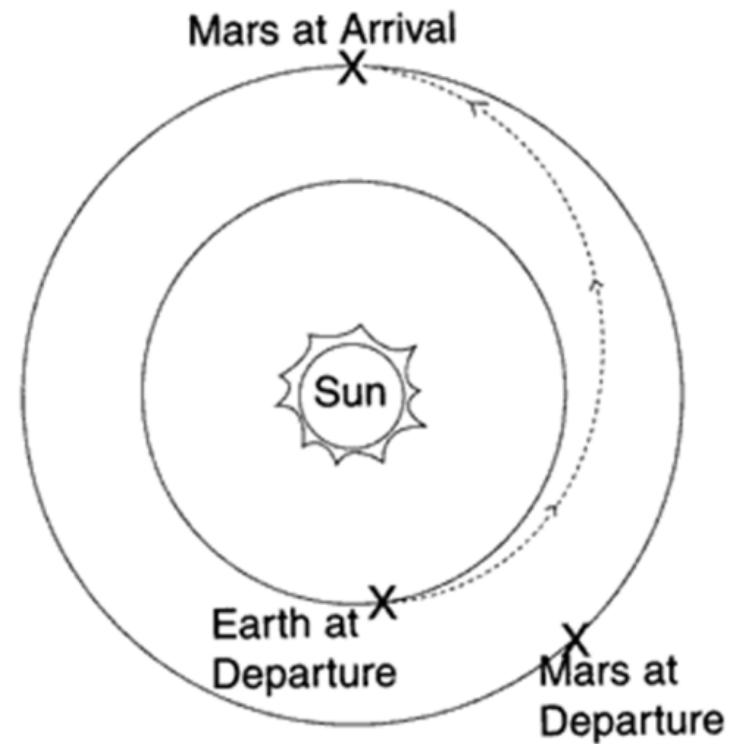
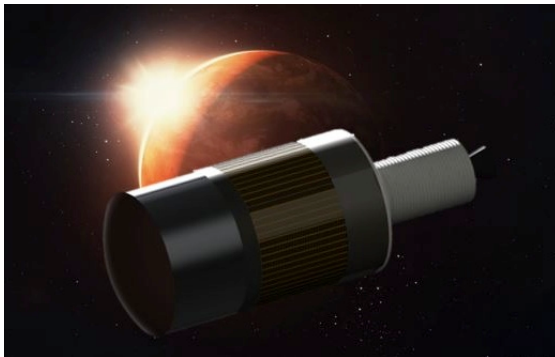



AEROBRAKING

- Upon rendezvous with Mars
 - Interplanetary transit module booster stage detaches
 - Inflatable heat shield will deploy
- Aerobraking maneuver
 - Highly elliptical orbit around Mars
 - Several aerobraking passes reduces velocity to roughly 3.5 km/s

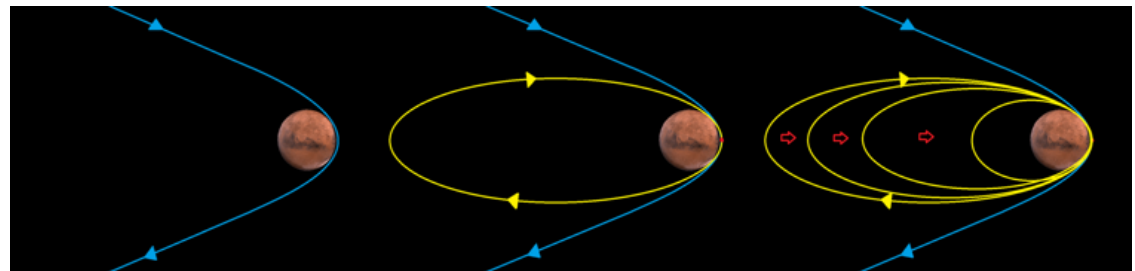
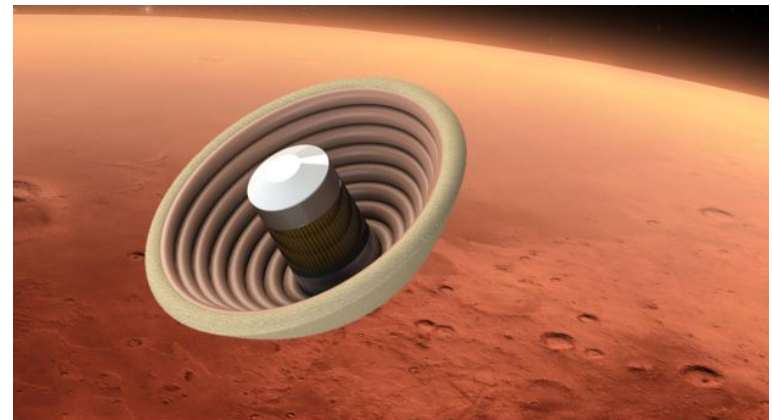



ENTRY

- Burning through the thin atmosphere
 - Reduce speed to Mach 2
 - Supersonic parachute deploys
- Past supersonic region
 - Inflatable heat shield and supersonic parachutes detach
 - Subsonic parachute deploys
- 5 km above the Mars surface
 - Retro-thrusters engage → subsonic parachute detaches
 - Retro thrusters
 - Slow to near zero velocity above landing zone
- Vehicle makes adjustment to final landing zone
 - Based on terrain
- Landed
 - Retro-thrusters detach from the module → eject themselves
 - Landing struts level module for deployment of greenwings

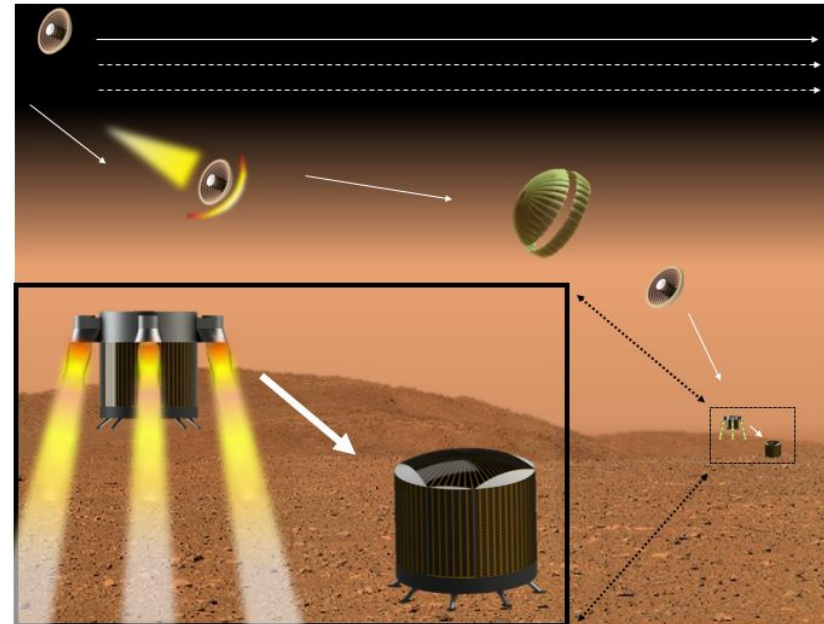

PACKED VS DEPLOYED

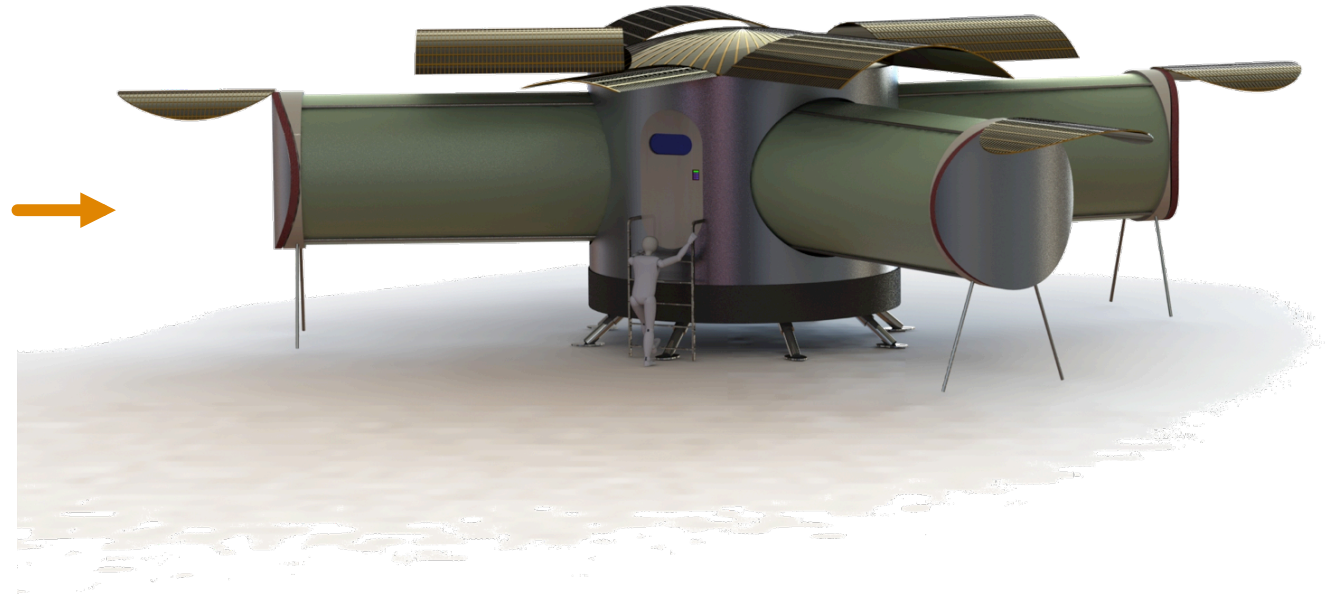

OASIS (Organics and Agricultural Sustainment Inflatable System)

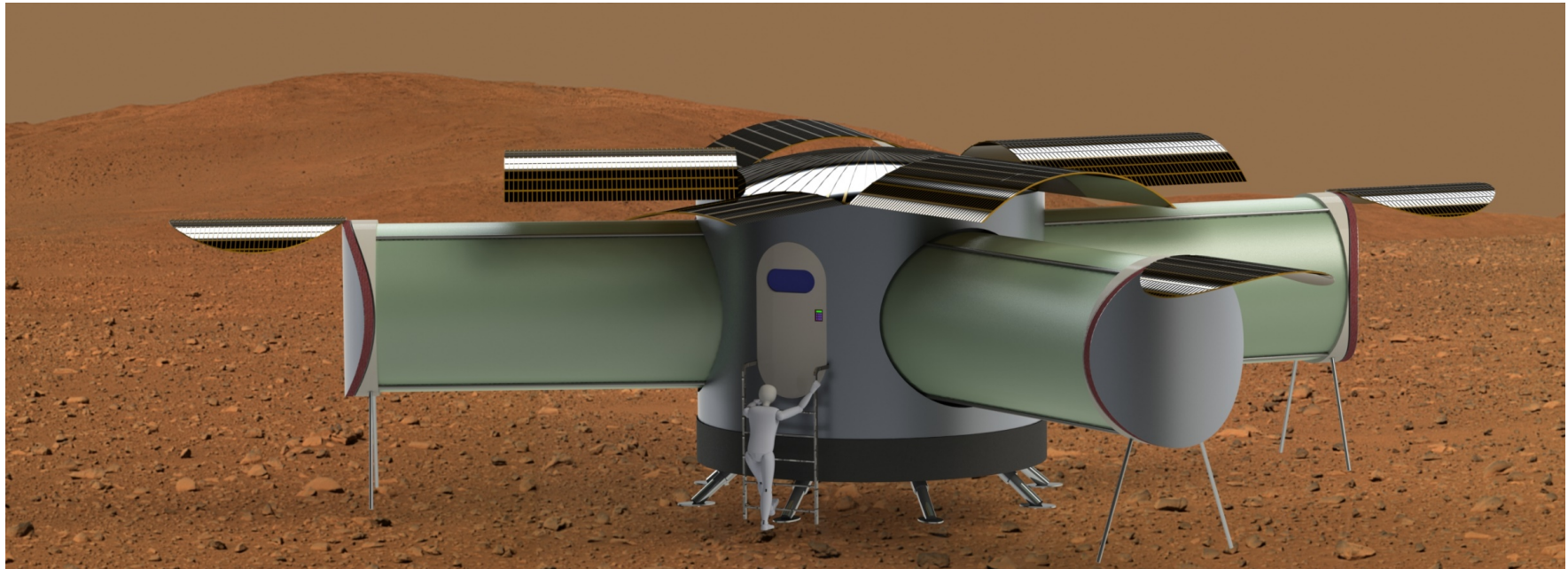

OASIS



- Solid central structure
 - Pressure vessel design
 - Similar to NASA's HDU and ISS modules
- Four inflatable soft-goods cylindrical tubes expanding outward
 - Inflatable tube structures – greenwings
 - Contain plant growth systems
- Greenwings
 - Spacesuit-like design
 - Layers of flexible materials
- Internal pressure of 60kPa
 - Minimize the structural weight
 - Breathable atmosphere composition
- Less than 7 tons

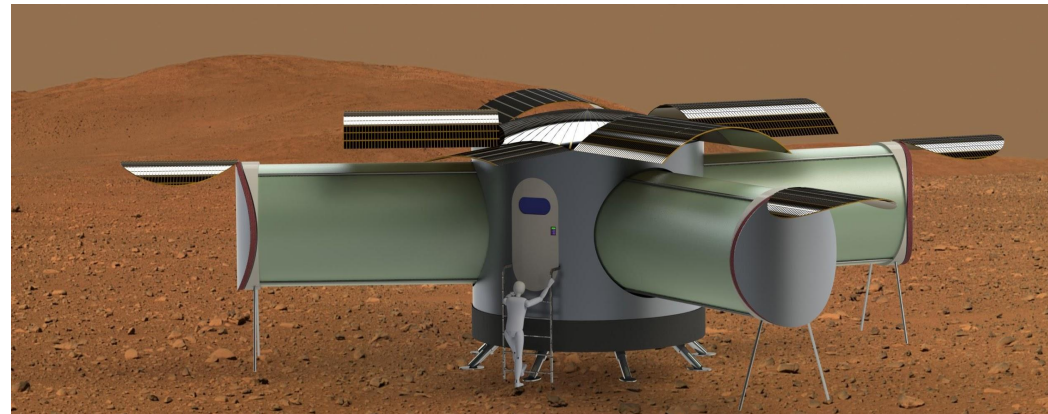

CENTRAL HUB



- Radius 4.6m
- Height 4m total (including 0.5m domes on top/bottom)
- Wall thickness 13cm (ISS/HDU derived)
 - Inner pressure vessel 2mm skin thickness
 - Insulation
 - I-beam rib structure
 - Honeycomb stiffener
 - Outer pressure vessel 3mm skin thickness
- Internal Pressure 60kpa

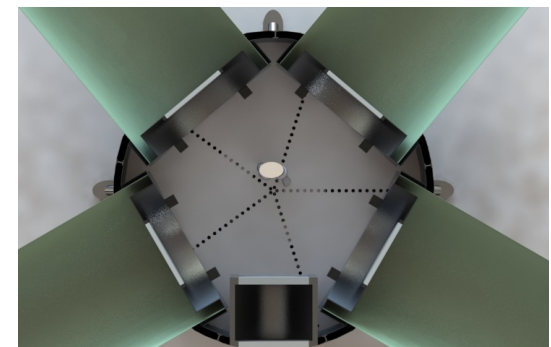
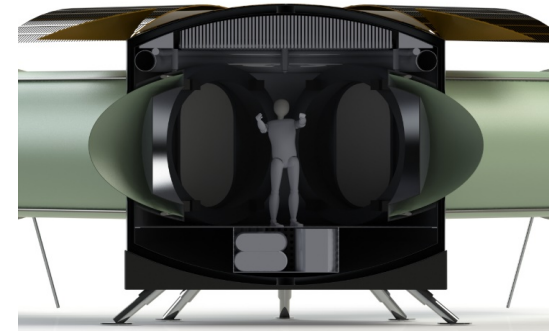



CENTRAL HUB BULKHEADS

- Four bulk heads isolating greenwings
- Same pressure on both sides
- Provide greenwing packing volume and attachment
- Facilitate specific greenwing atmosphere compositions

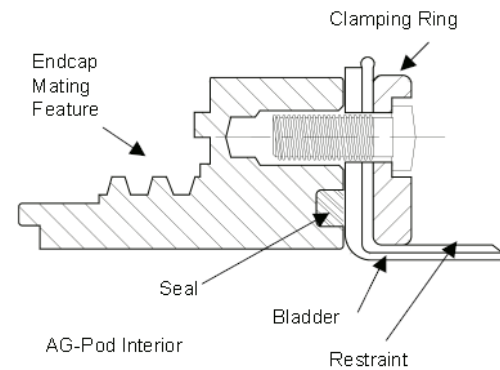
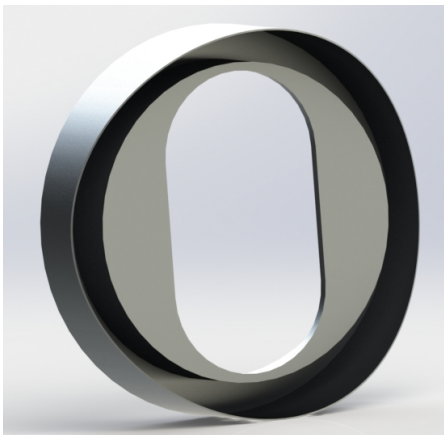
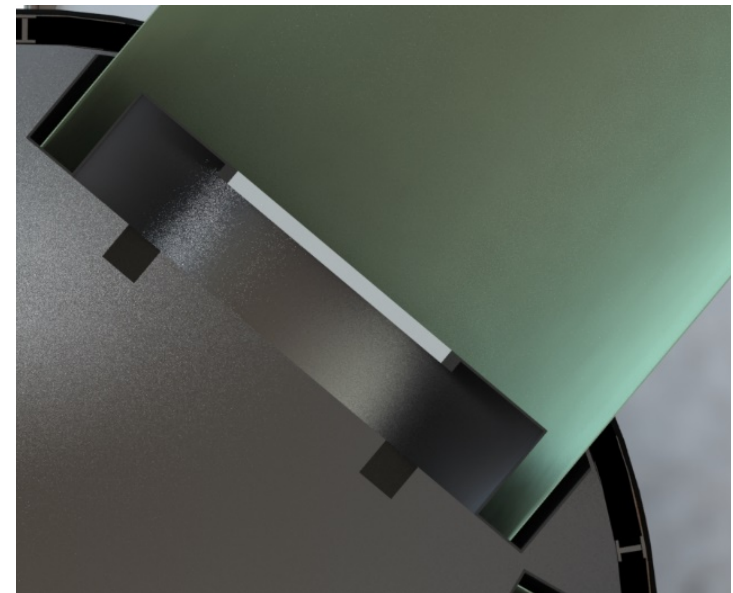

Figure 8 Typical flange joint design for softgoods mating.





CENTRAL HUB SYSTEMS

- Upper systems bay
 - CO2 collection
 - Fire suppression system
 - Humidity control
 - HVAC
 - Ventilation system
- Lower systems bay
 - Atmosphere storage tanks
 - Solar power storage batteries
 - Plant growth systems

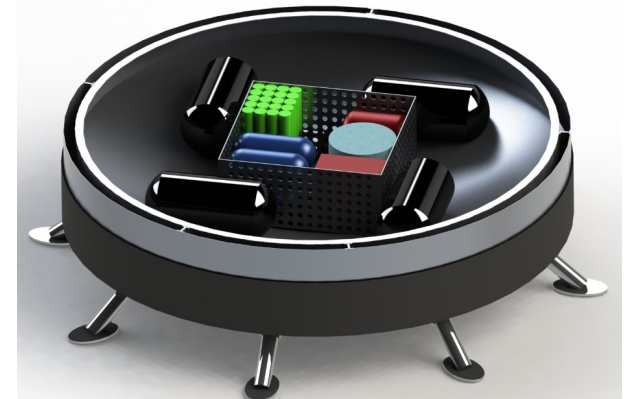
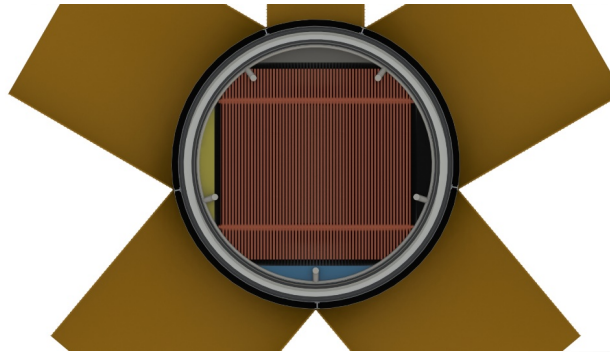

GREENWINGS



- Four greenwing, that contain crops
- Internal Pressure of 60kPa
- Wall thickness 4.8mm
- 2.2m diameter
- 5m length
- Inflatable construction
- Solid endcap
- Micro-castpiles

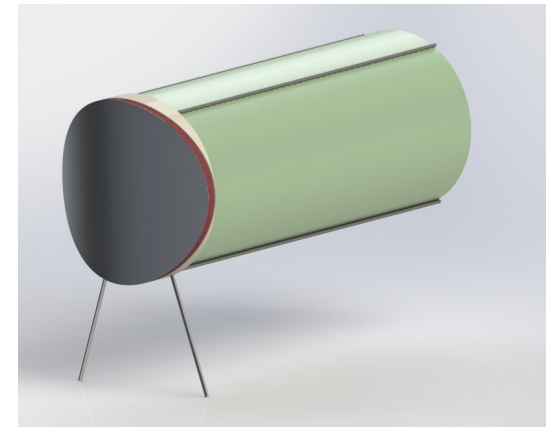
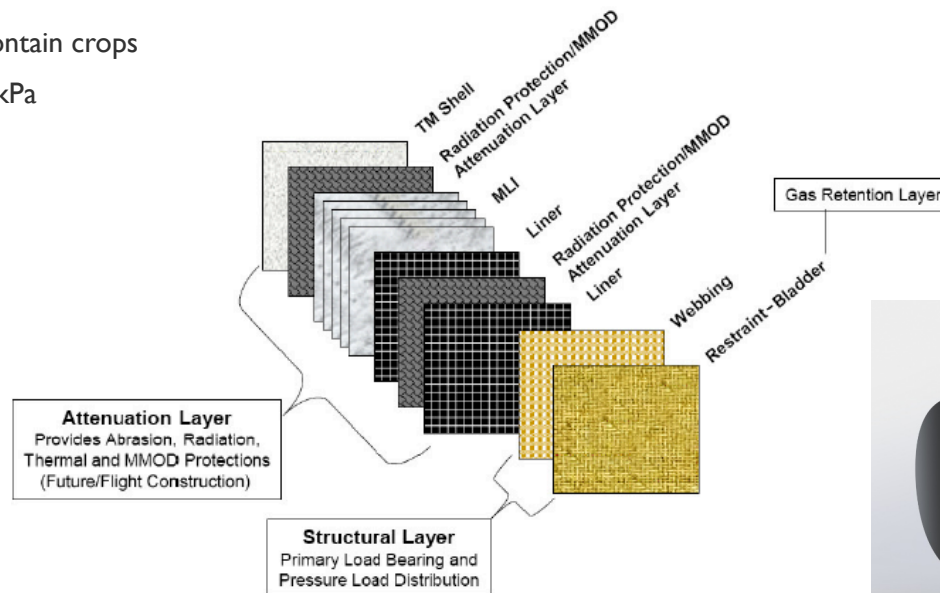

GREENWINGS INTERIOR



- Strap-based system
 - Varying plant sizes
 - Ideal light distances
 - Adaptability
- Specifications
 - Walkway width 1.2m
 - Walkway height 1.9m

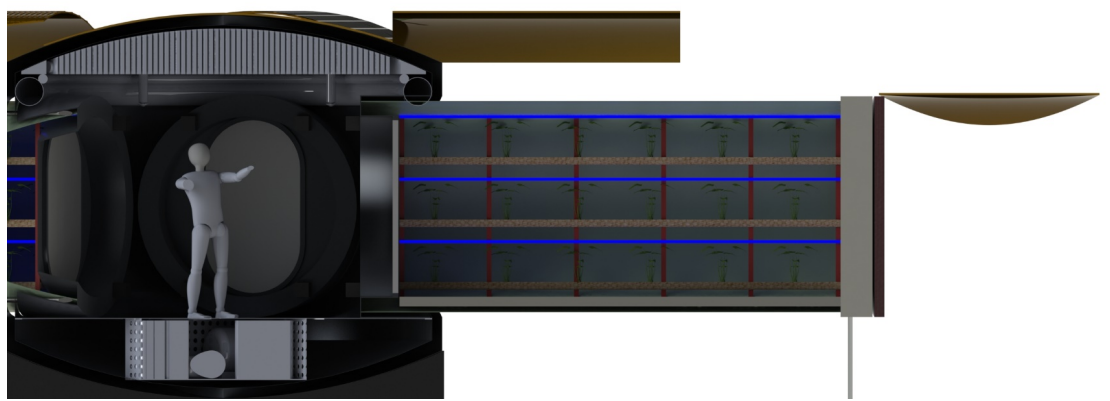
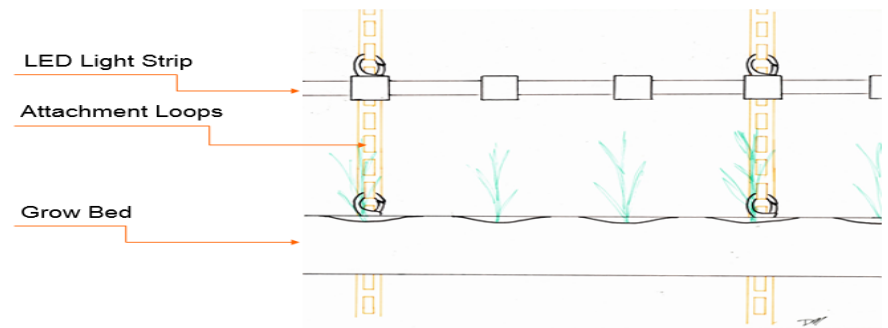



GREENWINGS LED LIGHTING

- LED strings are packable, lightweight, and easily fit design dimensions
- High TRL: 6 -7, many models available commercially
- Typical plants require 300-600 $\mu\text{mol}/\text{m}^2\text{s}$ (Photosynthetic Photon Flux Density) for normal growth
- Most effective wavelengths for Photosynthesis are around 470nm (Royal Blue) and 690 nm (Deep Red)
- With efficient LED growth lights, 250-425W/m² are required

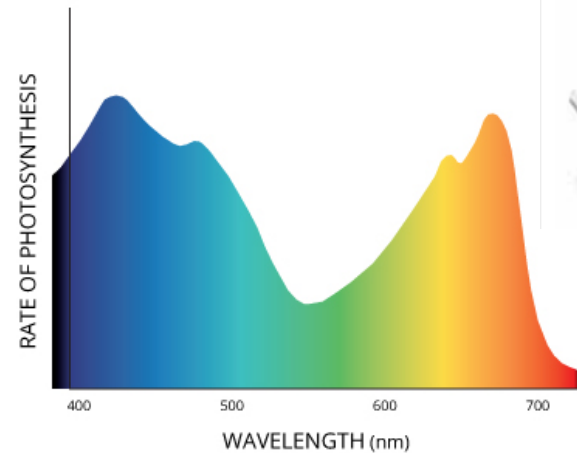



SOLAR ARRAY CAPABILITIES

- Hybrid System utilizing both Rigid and Flexible Solar Cells
 - Rigid Solar Cells unfold after landing
 - Flexible Solar Cells mounted along each Greenwing
- Total solar panel area 97m²
- Power generation at peak collection and ideal conditions could be as high as 25kW
 - Solar panel efficiency 40%
 - Average Solar irradiance 590 W/m² (at peak times)
- Additional solar panel arrays could be added

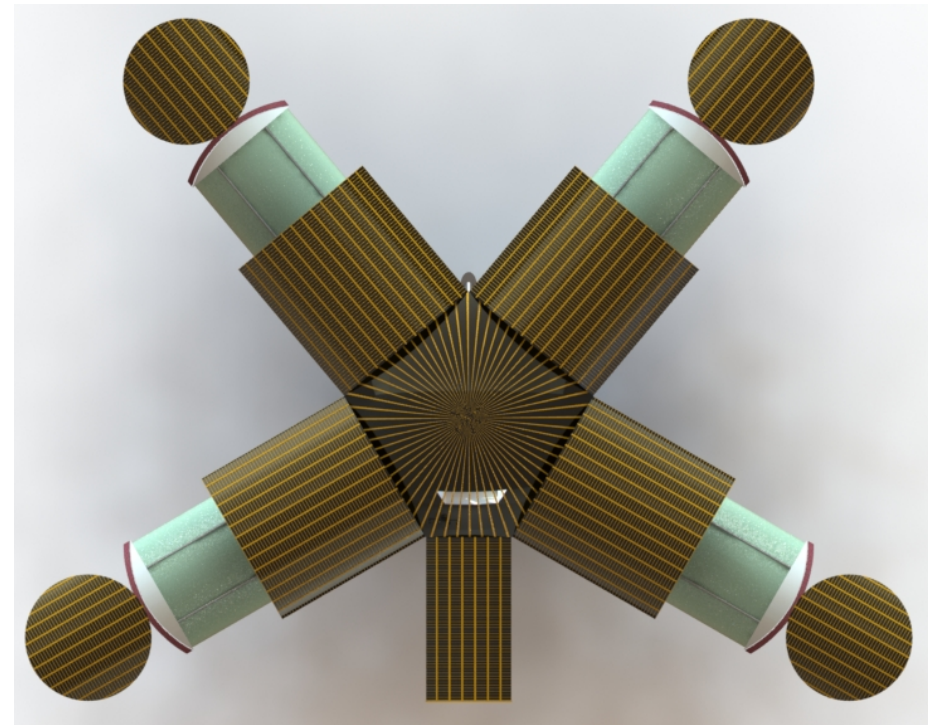



DEPLOYMENT

- Landing struts stabilize, Solar panel arrays open, Greenings inflate, Micro-castpiles deploy, Endcap solar arrays open
- Autonomous deployment and inflation
- System activates prior to astronaut arrival
 - Ensures operating food source
 - Advanced warning for failure and procedure

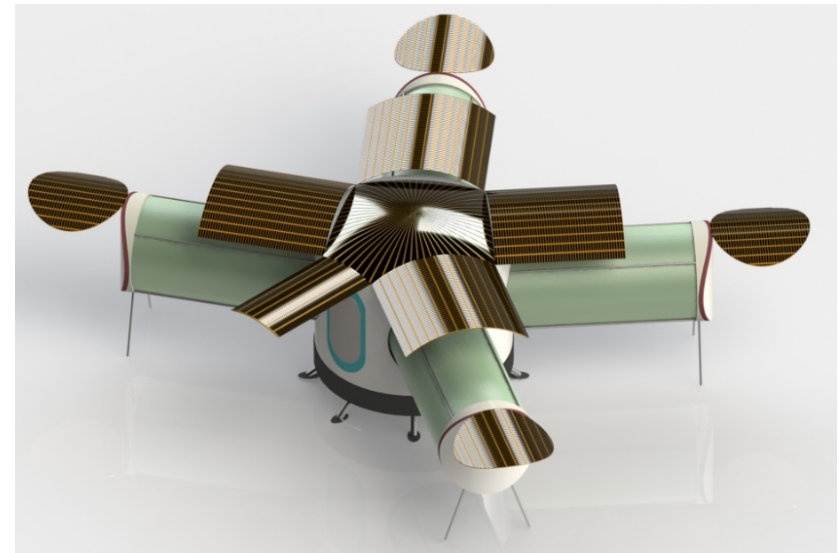
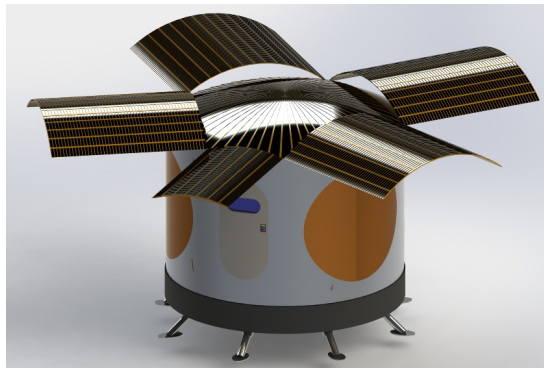



GREENWING DEPLOYMENT

- Constant pressure throughout deployment
- Slow and controlled to prevent structural failure due to rapid inflation
- Inflation ceases when pressure reaches 60 kPa (cold)
- Tension cables control inflation
 - 1.86 GPa breaking point
 - 6 mm diameter cable

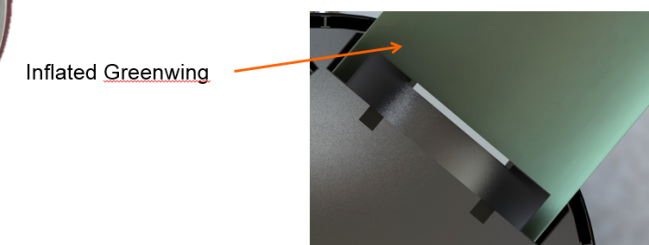
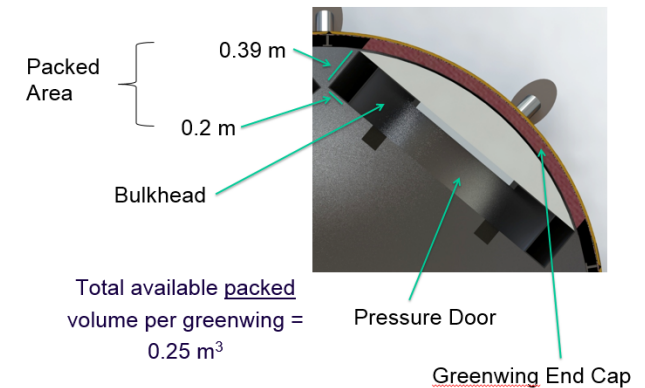
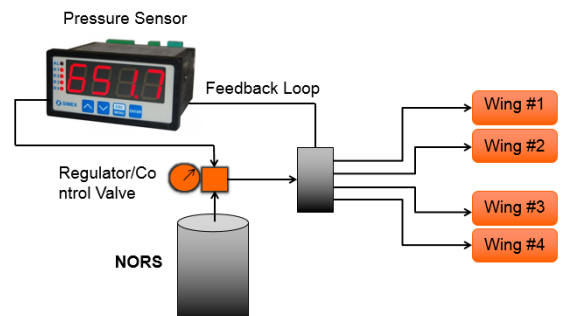



OASIS SPECIFICATIONS

- Widest span 18m
- Max height 5m
- Weight estimation 6.3t
- Total useful interior volume 50.7 m³
- Production capabilities ~38lb/week

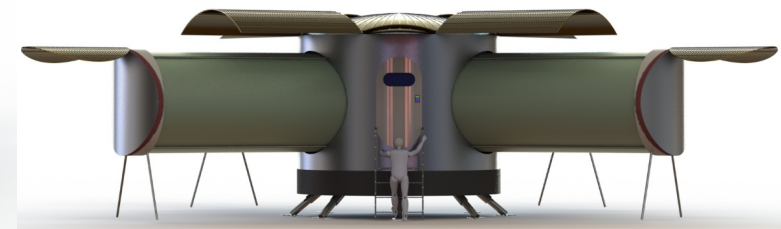
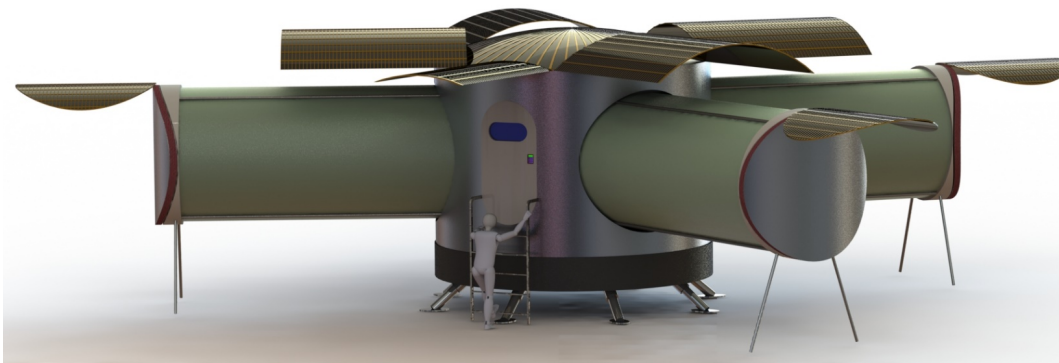
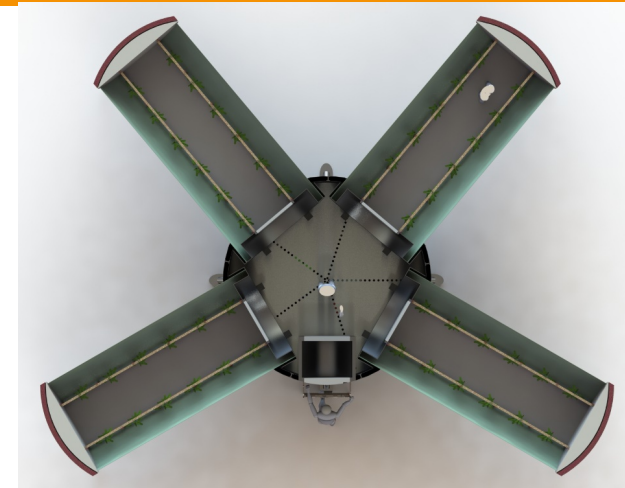

KELSEY KHOO



Interior Deployables Team
Team Lead

TESTING/ANALOGS



- Full-scale analog of a greenwing
- 1:5 scale inflatable greenwing
- 1:20 scale architectural model
- Small-scale aeroponic system
- Control systems
 - Lighting
 - Nutrient
 - Monitoring

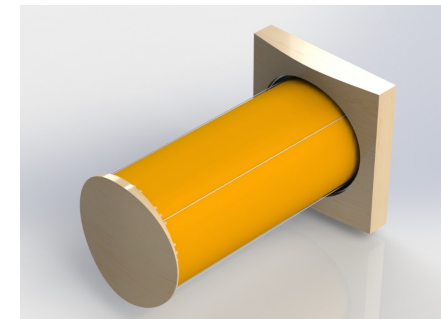
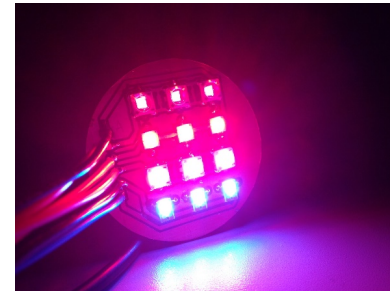



FULL-SCALE ANALOG

- Analog of a greenwing
- Sections
 - Functional aerponics
 - Interior deployables
 - Avionics
 - Presentation
- HVAC
- Lighting

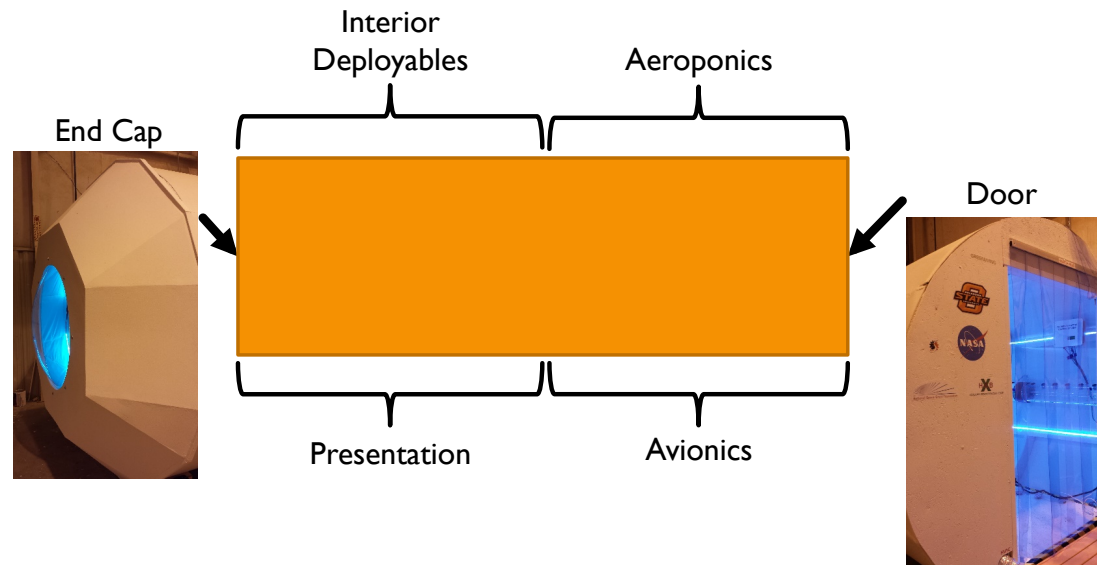

CONSTRUCTION PROCESS



Constructed ribs



Attached and assembled structural shell



Attached luan to simulate outer skin



Fabricated end cap and installed window



Installed interior and aesthetic components

ZACHERY PLUMMER



HVAC and RIP Panels Team

VENTILATION (HVAC)

- Team Members
 - Derek Carrington
 - Zachery Plummer
- “Highly” Modified Frigidaire Window AC Unit
 - 6000 BTU
 - 115V
 - Rated for 250 sq. ft.
- Man Hours: 60 hours
- Budget: \$450



HVAC

$V: \text{VOLUME} = 24.5 \text{ m}^3$

$\eta: 3 \text{ AIR CHANGES/HR}$

$\dot{V} = V \cdot \eta \cdot \left(\frac{1 \text{ HR.}}{60 \text{ MIN.}}\right) = 1.23 \frac{\text{m}^3}{\text{MIN}}$

$\dot{V} = 1.23 \frac{\text{m}^3}{\text{MIN}}$

VENTILATION (HVAC)

- One main line, 4 branches to 4 vents mounted at top of model (between each rib)
- HVAC Mounting
 - Metal Pipe Hangers on 2x4 support structure
 - Velcro Pipe Hangers on structural skin to keep shape
 - Screws into 2x4 through vent
 - Cold weather thermal tape to seal and secure junctions.
 - Plywood box and supports



DEREK CARRINGTON



HVAC and RIP Panels Team

REMOVABLE INTERIOR POLYURETHANE (RIP) PANELS

- Team Members:
 - Derek Carrington
 - Zachery Plummer
- Man Hours: 90 hours
- Budget: \$400

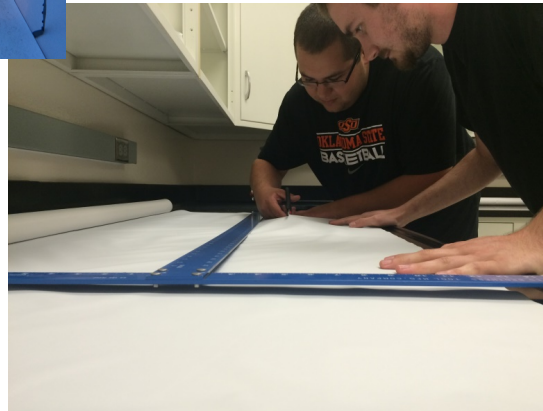

REMOVABLE INTERIOR POLYURETHANE (RIP) PANELS

- Polyurethane Coated Nylon
- 28 Removable Panels
- Attached via Velcro
 - Allow for forming to the curved ribs
 - Easily removable



RIP Panels

	1.23m	1.21m	1.21m	1.23m	
	3	9	15	21	0.91m
	2	8	14	20	1.02m
	1	7	13	19	0.61m
Endcap	16	12	18	24	0.91m
	6	12	18	24	0.33m
	5	11	17	23	1.02m
	4	10	16	22	0.91m

* 90° head to floor



CONNOR BECK



Avionics Team



PROTOTYPE PLANT GROWTH LIGHT PODS

- Robust design for Plants vs. Minimalist design for Space
- Series of 12 LED's emit light with a wavelength that optimizes plant growth
- Disc shaped pods are compact and allow for future deployability testing

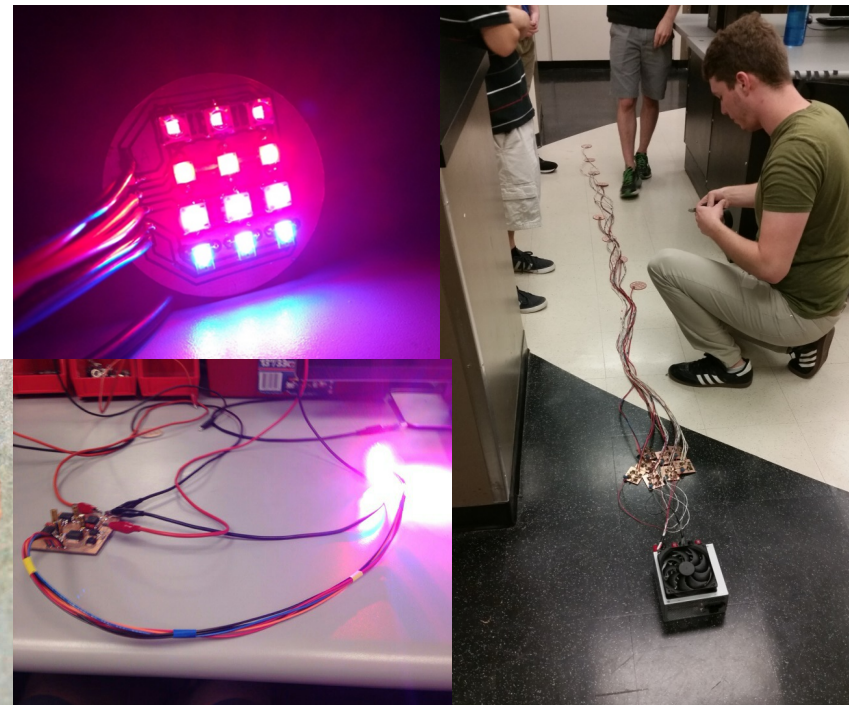
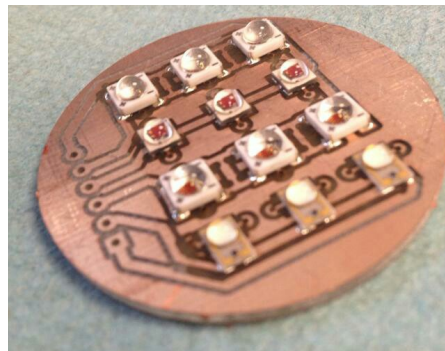

INTERIOR LIGHTING TOUCHSCREEN CONTROL

- Proof of Concept for Human Interface in Greenwings
- Raspberry Pi-based touchscreen control allows for a more compact control system
- Open-ended design allows for integration with future control systems:
 - Growth Light Automation
 - Climate Monitoring
 - Nutrient Solution Monitoring & Control

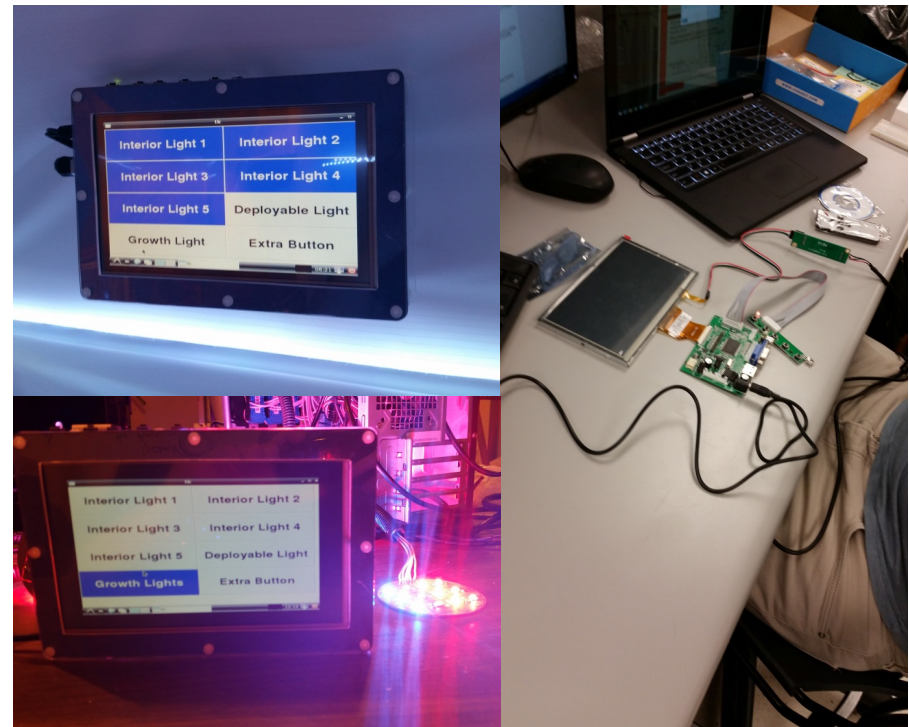

KELSEY KHOO



Interior Deployables Team
Team Lead

DEPLOYABLE SECTION

- Materials
 - Polyurethane coated nylon
 - Braided steel cable
 - Carabineers
 - Key rings
 - LED strips
- Testing
 - Modularity
 - Human factors/ergonomics
 - Deployability

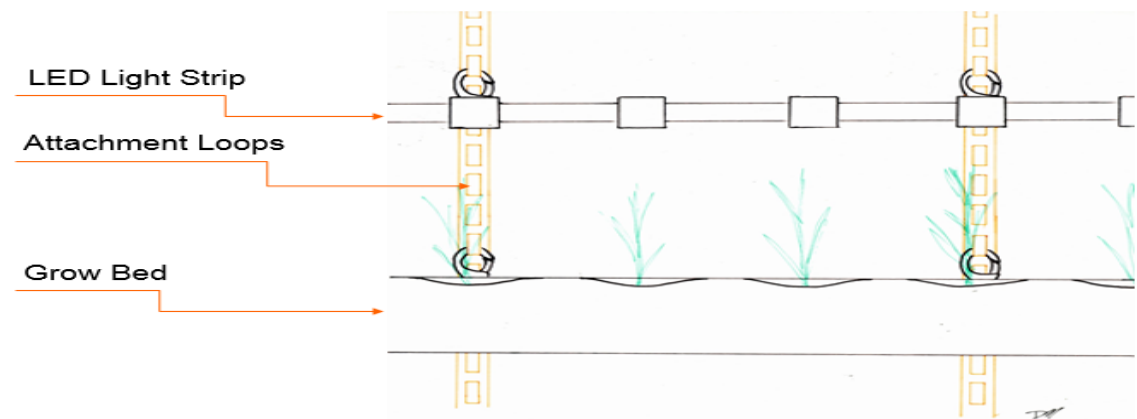

DEPLOYABLE SECTION



JONATHAN OVERTON



Biosystems Team Lead

AEROPONICS SYSTEM



- 8 ft long
- Maximum 14 plants
- Pumps move nutrient solution through pipes
- Clear section for internal visibility



SMALL SCALE AEROPONICS

- 20 plant test unit at ARS greenhouse
 - In situ germination had low germination rate
 - Coffee filter germination was successful



LIGHT CONTROL SYSTEM

OLIVIA BROUSSARD, ABIGAIL PARNELL, & SETH CLEARY

- Controls lighting for individual plant species
 - Location code typed into keypad
 - Selected greenwing and plant displayed on screen
 - Provides light at optimal growth periods
- User interface requires minimal physical input

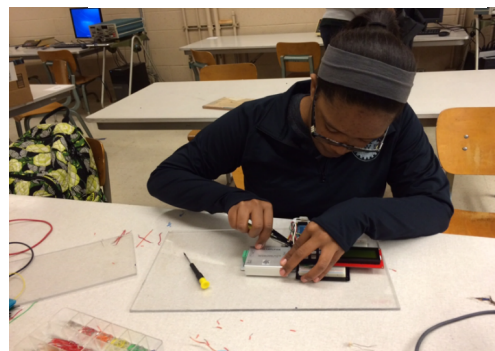
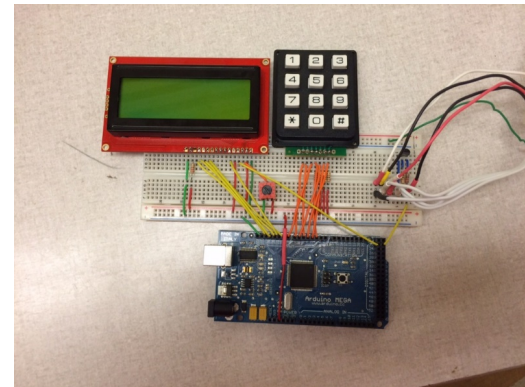
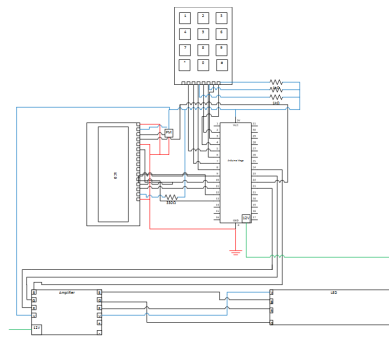

CLIMATE MONITORING SYSTEM

BRANDY GREEN, CORTNEY BROMENSHENK, & ANDREW FARRAND

- Collects the indoor climate parameters
- Displays the results on LCD screen
- Speaker will sound unless conditions met
 - Temperature: $18^{\circ}\text{C} < T < 24^{\circ}\text{C}$
 - Humidity: $20\% < \% < 80\%$
 - Air pressure: $9 \text{ psia} < P < 10 \text{ psia}$

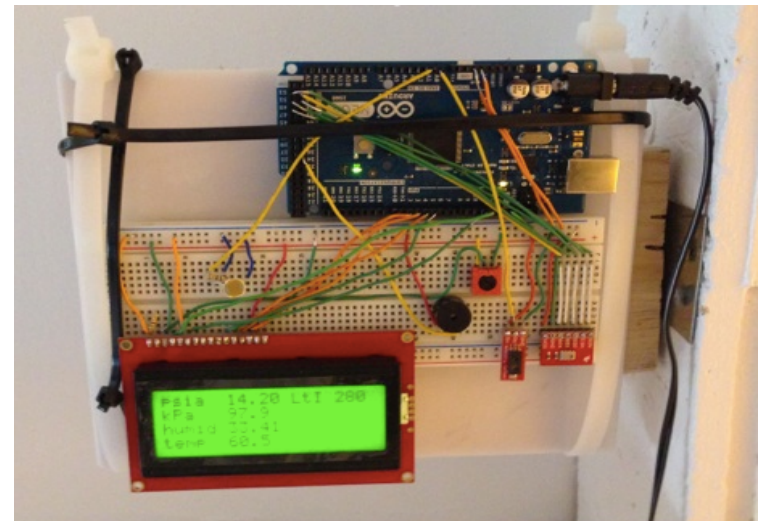
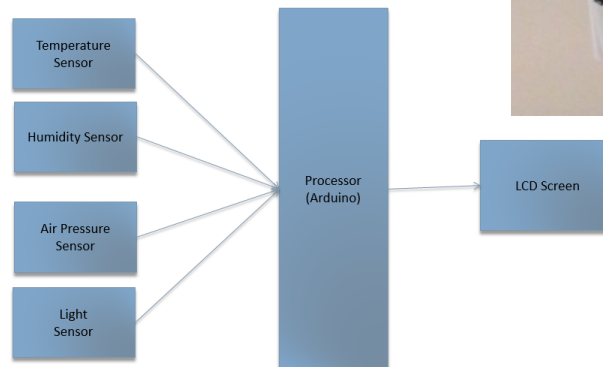

CONTROL SYSTEM FOR A NUTRITION SOLUTION SUPPLY SYSTEM

TAYLOR CONLEY, GUY STUART BARKER, & SHELBY WEBER

- Controls pumps feeding the aeroponics section
 - Water barrel
 - Mixed Solution
 - Recycled Solution
- LCD screen displays pH, electroconductivity (EC), and temperature

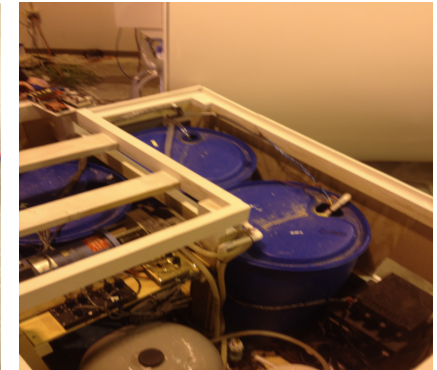
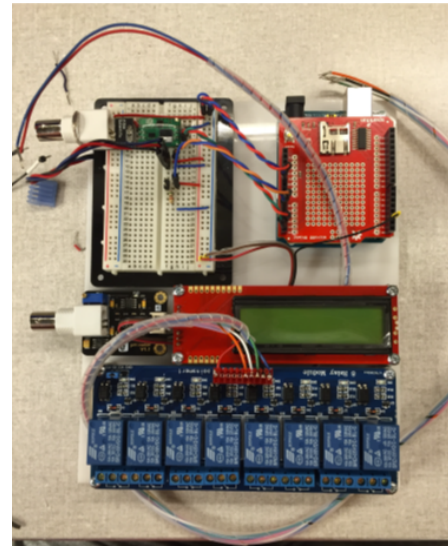

CONTROL SYSTEM FOR DEPLOYING GREENWING

CHANCE BORGER & ALVARO MONTES

- Determines distance traveled by greenwing end
- Monitors internal pressure of the inflatable
- Created model to test system
 - Motorized system to deploy greenwing
 - Stops system automatically when deploying is complete
- If deploys too far out, can bring back in

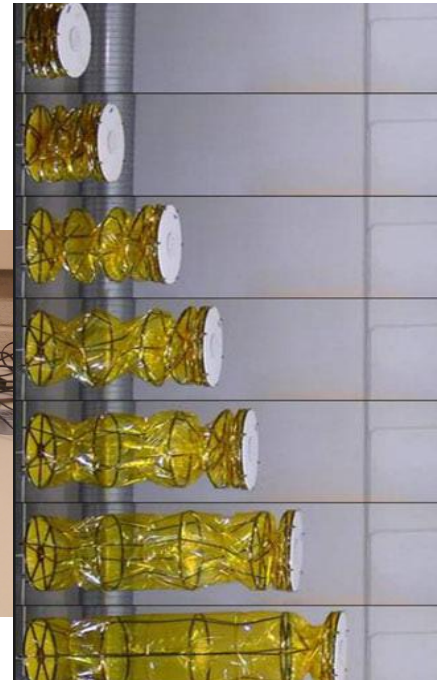
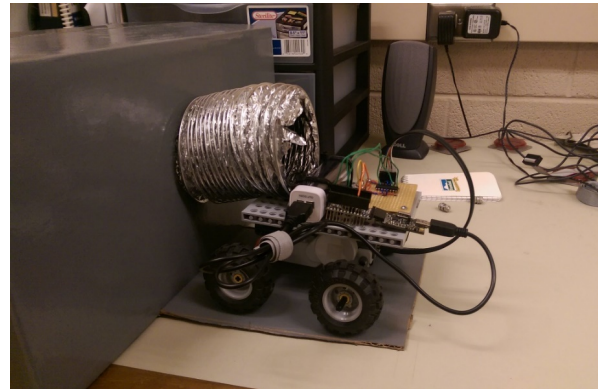

SHANE SPEAR



Deployment Analog Team

I:5 SCALE MODEL

- **Purpose**
 - Proof of concept for deployment system
 - Evaluate effectiveness of tension cables in the deployment process



Team Members

Ariel Barnes

Shane Spear

PROCESS

1. Developed CAD Model
2. Deployment Testing of Smaller Scale System
3. Developed Tension Cable Mockup
4. Built End Cap and 1/5 Scale Wing
5. Tested Integrity of Tube
6. Test Tension Cables
7. Integrate Inflation Program
8. Test Deployment Process

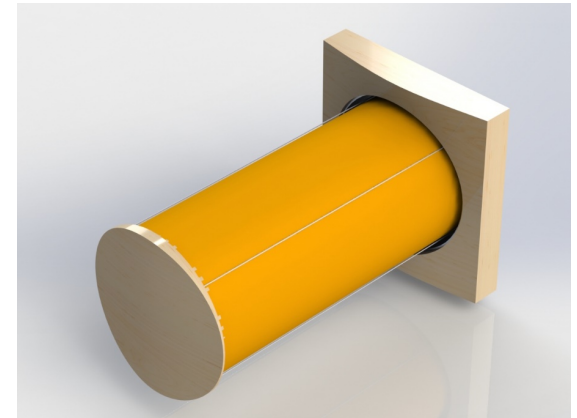

TENSION CABLES

- Purpose:
 - As beam inflates, cables in tension control deployment
 - Support inflated beam

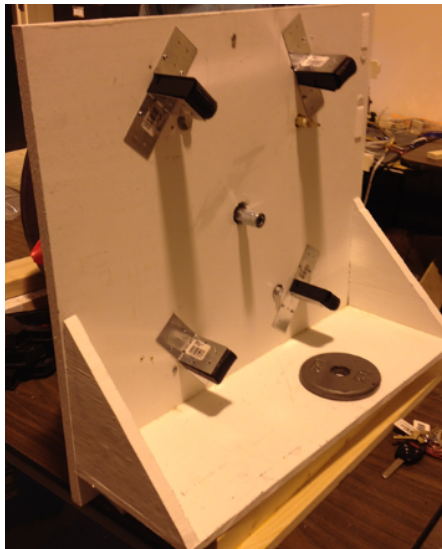

- In full scale design:
 - Cables react as a function of distance
 - Model uses constant force spring reels instead

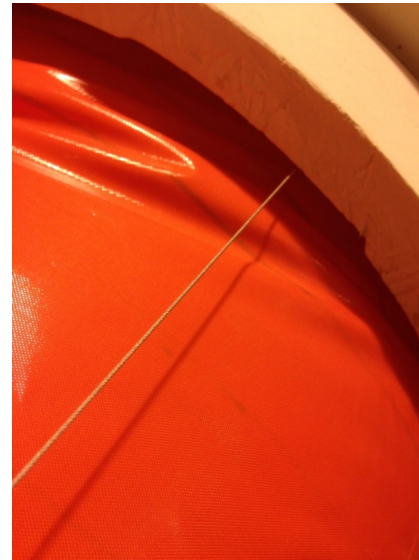

INITIAL INFLATION

- Attached Tube
- Inflation Integrity Test
 - Added a bladder to aid against leaks

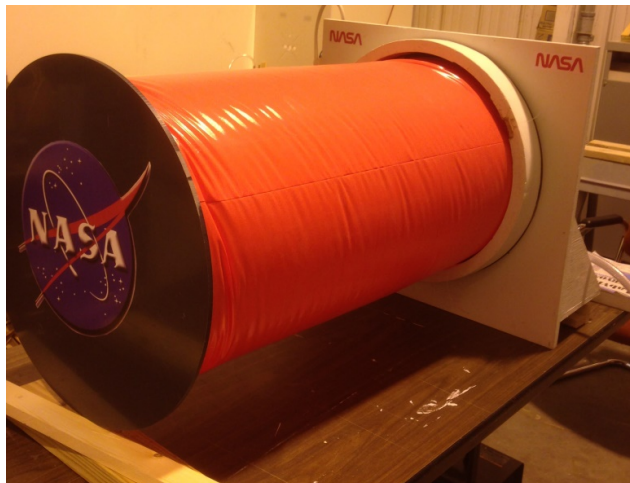
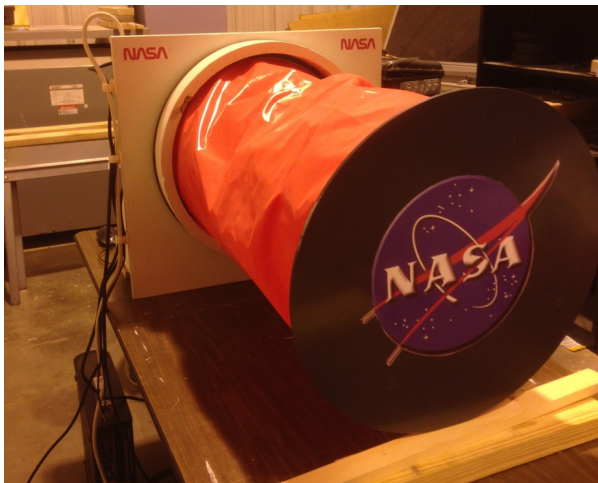

CAD: BULKHEAD

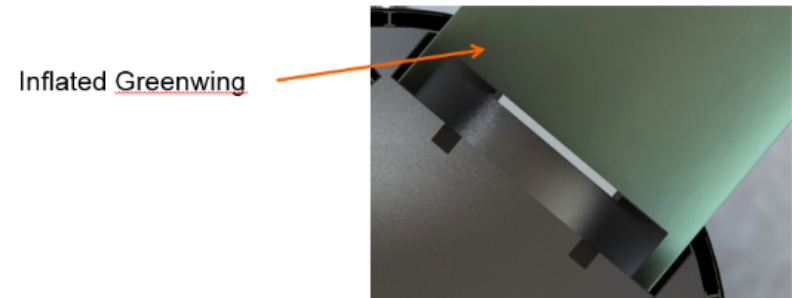
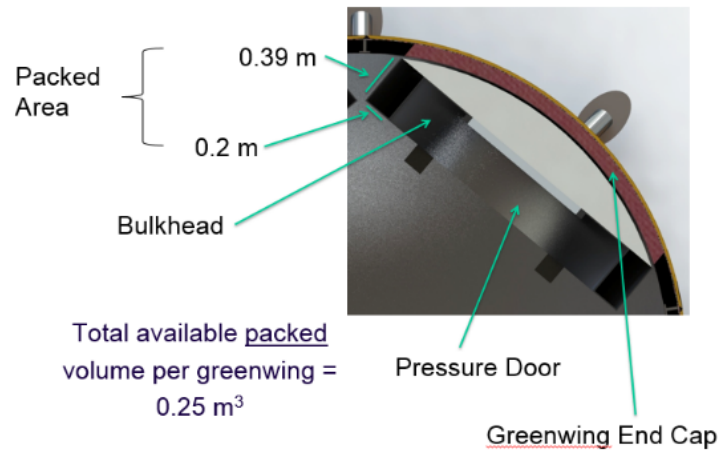

Total available inflated volume per greenwing = 19 m³

DEPLOYMENT PROCESS

- Wing is packed into bulk head
- Wing is deployed
- Tension cables help control inflation and guide endcap

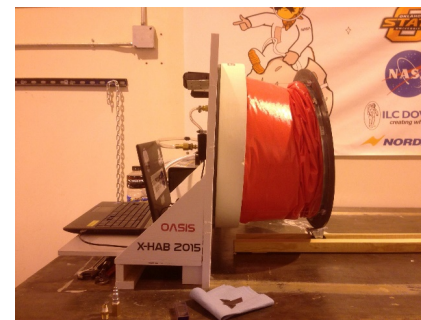
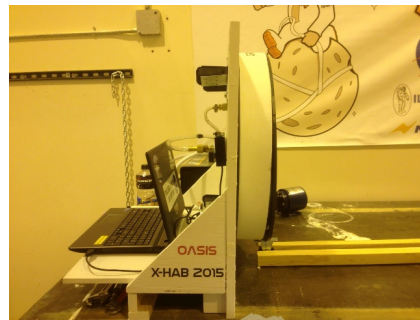

INFLATION

- Pressure required to support the beam is given by the following relation:

$$P = \frac{16M}{\pi D^3}$$

- For approx. 3lb. endcap, this results in a pressure of 0.1psi.
 - At this pressure, the beam is capable of supporting itself
- Test results and recommendations:
 - Small leaks around the endcaps
 - Solution: incorporate closed bladder rather than open ended bladder.

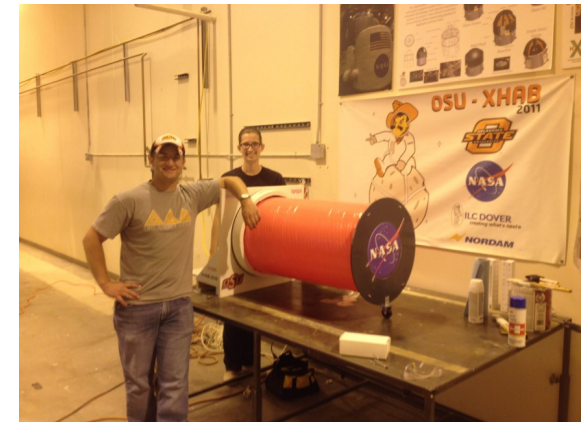

INFLATION PROGRAM

- LabVIEW Program
 - Used for pressure monitoring
- In the future:
 - Have fully autonomous inflation via LabVIEW

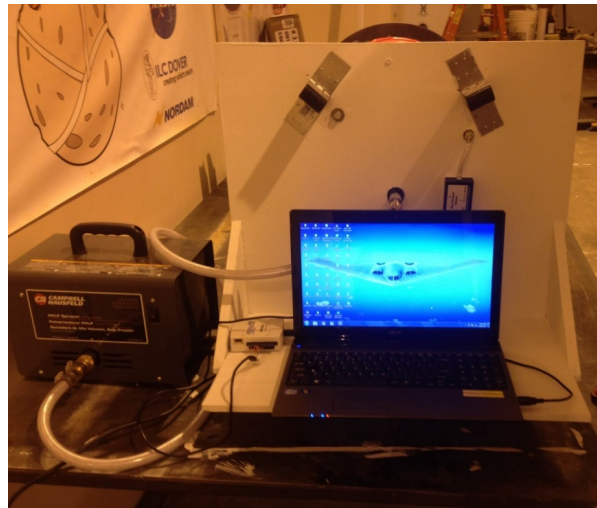



ARCHITECTURAL MODEL

- 1:20 scale
- Overall design of the OASIS System
- Accurately depict stages of greenwing deployment
- 3-D printed hub and end caps
- Solar panels

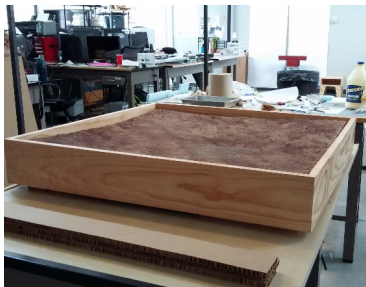
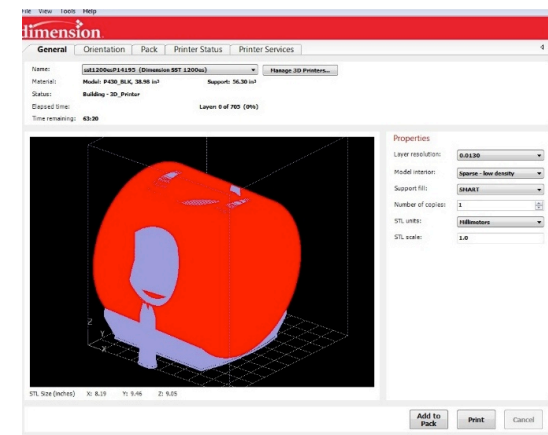

KELSEY KHOO



Interior Deployables Team
Team Lead

MARSHALL SPACE FLIGHT CENTER

- Toured facility with Charles Dischinger
 - Flight Robotics Lab
 - Large Structural Test Facilities
 - Human Factors Engineering for SLS
 - Historic Redstone Test Stands
- U.S. Space & Rocket Center



OUTREACH

- National Lab Day
 - Bring discovery-based science experiments to K-12 students
 - Showcase labs from 3 colleges at OSU
 - High school students and teachers from 17 schools visit labs across campus
 - Sample mission scenario using analogs



QUESTIONS?

