



Validation of Universal Cryogenic Flow Boiling Correlations in Thermal Desktop for Liquid Helium

Erin Tesny¹, Jason Hartwig¹, Vishwanath Ganesan², Issam Mudawar², Mariano Mercado¹

¹NASA Glenn Research Center

²Purdue University

*Presented at The 2023 Cryogenic
Engineering Conference
Honolulu, HI
July 11, 2023*

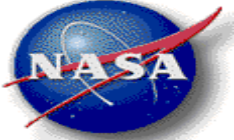

Outline

- Introduction
- Background
- Built-In Thermal Desktop Flow Boiling Correlations
- New Universal Correlations
- Model Set-Up
- Results
- Discussion and Future Work

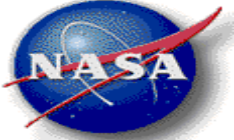

Introduction

- Cryogenic transfer systems are an emerging technology in both ground and low-g systems
- Two-phase pipe flow will be an inevitable part of these systems
- Accurate models are required to develop efficient, cost effective, and safe two-phase flow boiling/heat transfer systems
- Recently, attention has been drawn to the fact that existing room-temperature based models and correlations do a poor job in predicting cryogenic flow phenomena
 - For steady state or heated tube, the disparity between these models and cryogenic HTC data is as high as 400%
- To address this concern, direct cryogenic data anchored correlations and subroutines are systematically being developed and validated across the board for multiple cryogenic propellants and transfer phenomena



SpaceX Starship Cryo Proof Test
From <https://www.nasaspaceflight.com/2020/04/starship-sn4-set-for-test/>



LH2 Storage Tank and transfer line at
NASA KSC

From <https://www.nasa.gov/feature/kennedy-plays-critical-role-in-large-scale-liquid-hydrogen-tank-development>

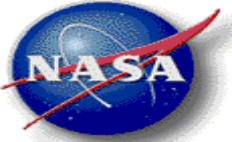

Background

- In heating, or steady state case, single phase liquid flow is already established, and an external heat source gradually boils the liquid
 - The heating configuration follows the boiling curve from left to right
- Existing correlations used for two phase flow are typically based on room temperature fluids and do not do a good job at prediction cryogenic behavior
- Universal correlations have been developed using existing cryogenic experimental data to cover the different boiling phenomena for cryogenic fluids
- Current work will show implementation of universal correlations into Thermal Desktop and compare against the Built-In TD code for a historical dataset using Helium

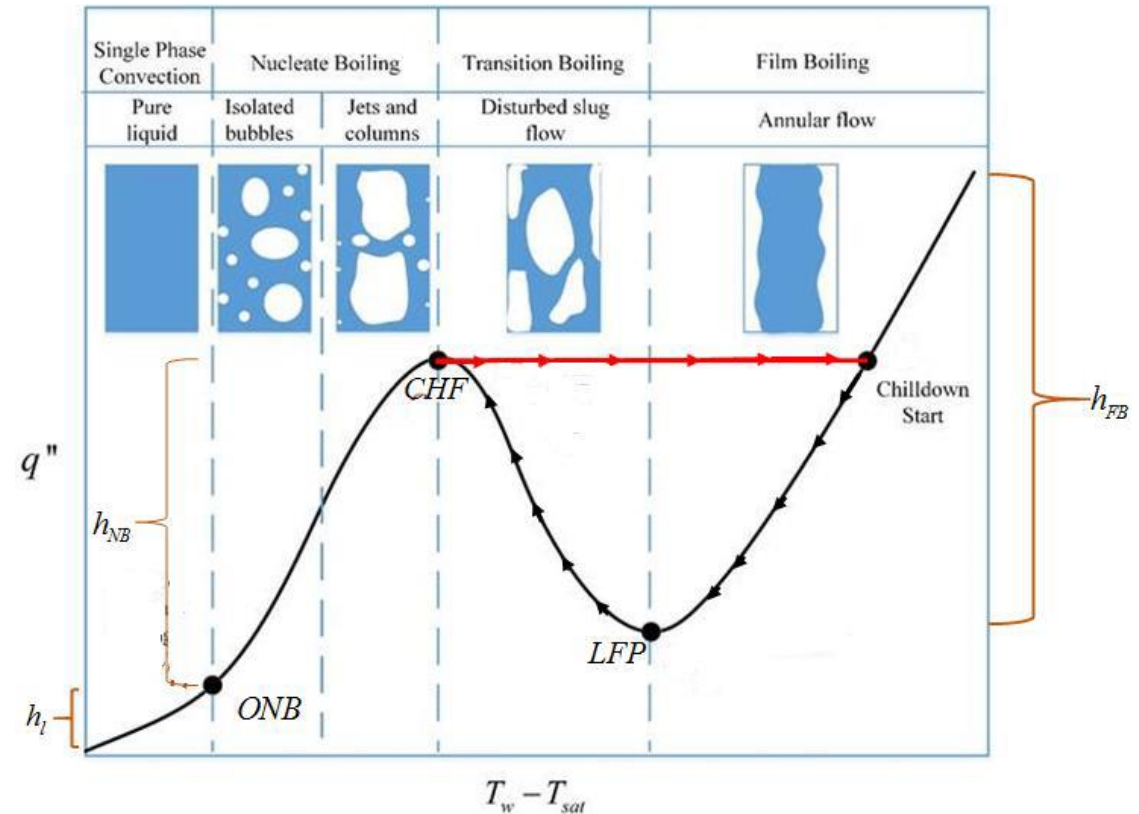

A typical boiling curve.
from Mercado et al., 2019

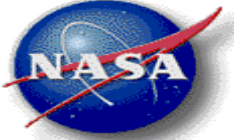

Built-in Thermal Desktop Correlation

- By default, Thermal Desktop recognizes two fundamental boiling heat transfer regimes: nucleate and film.
- Thermal Desktop decides which boiling correlation to use based on the wall superheat and flow quality in each fluid lump

| | Low Flow Quality ($x < XNB$) | High Flow Quality ($XNB < x < 1.0$) |
|---|---|---|
| Low Wall Superheat (below T_{CHF}) | Chen (1963) | Linear interpolation between Chen and Dittus-Boelter ($Nu = 0.023 Re^{0.8} Pr^{0.4}$) |
| Transition (between T_{CHF} and the smaller of T_{leid} and T_{dfb}) | Non-linear interpolation between nucleate and film boiling using scaling laws by Ramilison and Leinhard | Non-linear interpolation between nucleate and film boiling using scaling laws by Ramilison and Leinhard |
| High Wall Superheat (above the smaller of T_{leid} and T_{dfb}) | Bromley | Groeneveld |

XNB: cut-off quality for nucleate boiling, default is 0.7 but can be changed by user

T_{CHF} : critical heat flux temperature

T_{leid} : Leidenfrost temperature

T_{dfb} : departure from film boiling temperature

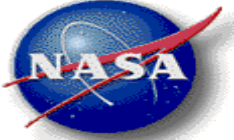

New Universal Correlations

- New Universal Cryogenic Correlations were developed at Purdue University
- The aim of these correlations was to create a continuous predictive model along the entire boiling curve
- Correlation was developed for pre-Critical Heat Flux (CHF) heat transfer coefficient, post-CHF heat transfer coefficient, and location of the CHF
- Universal Correlations originally developed in MATLAB
- Ported over into Thermal Desktop using a User Subroutine

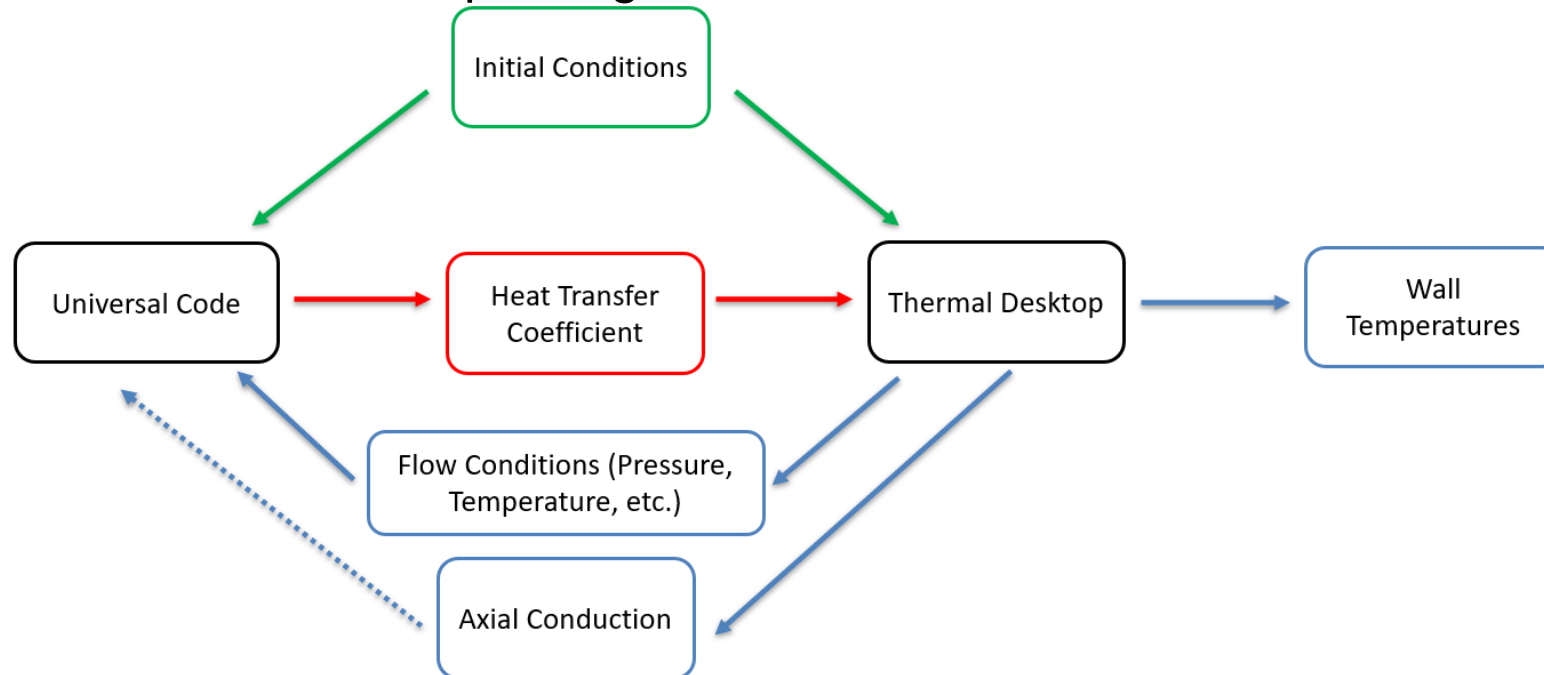

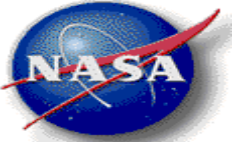

Experimental Set-Up

- Heated tube experiments are by definition steady state experiments
 - Typically, fluid and tube wall begin at the same temperature and heat is slowly delivered until the system reaches steady state for a fixed heat flux
- Giarrantano (1973):
 - Liquid Helium
 - Constant Heat Flux
 - Vertical Pipe
 - 10 cm length, 2.1 mm diameter
 - 10 data sets
 - 10 wall thermocouples

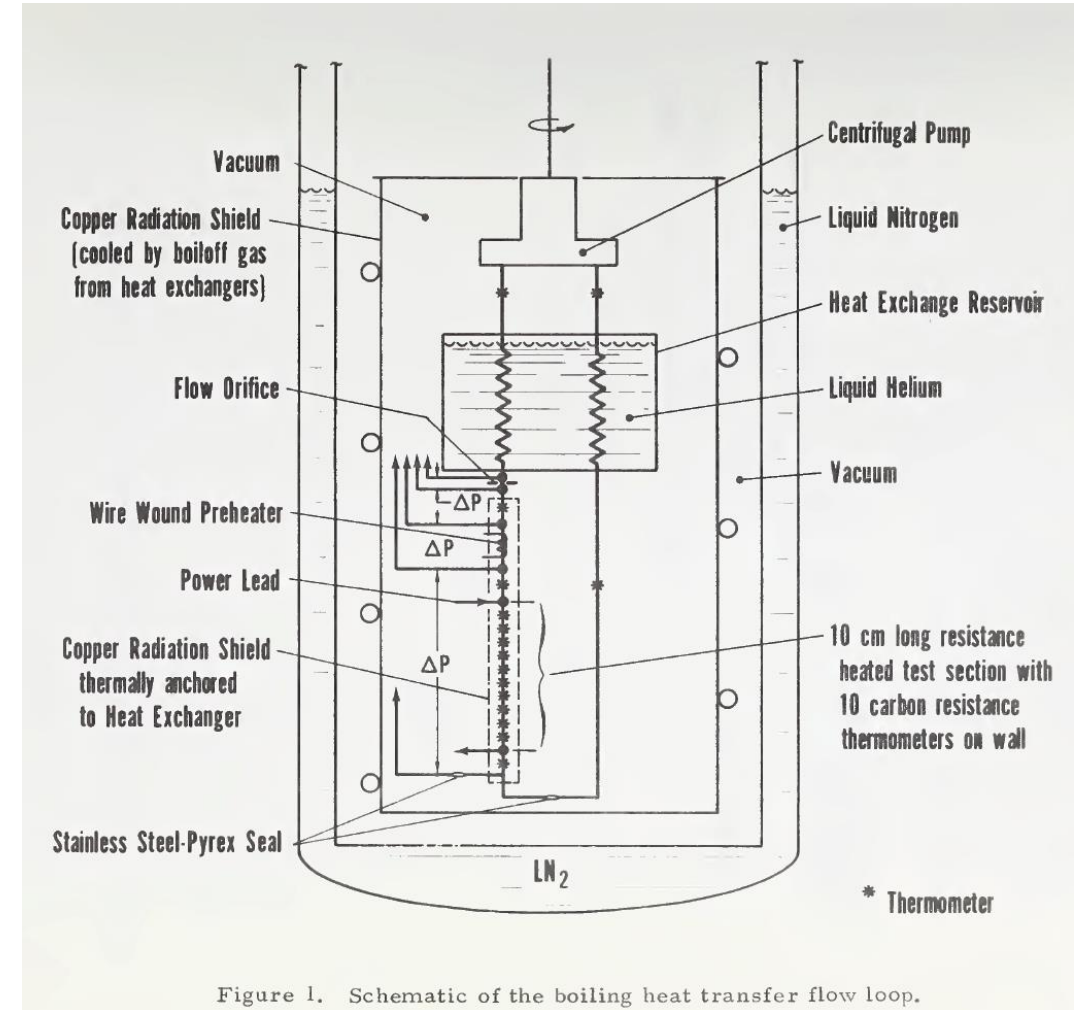

Experimental Set Up
from *Giarrantano et al., 1973*

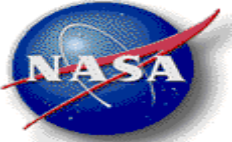

Experimental Set-Up

- Experiment test sections are modeled in Thermal Desktop as a single pipe object
- Inlet plenum fixes the inlet conditions going into the pipe
- Setflow path dictates the flow rate
- Constant heat flux is applied using a heat load on the inner surface of the pipe
- Fluid Lumps and Solid Nodes represent each segment of the pipe
- Lump and Nodes connected by Tie which dictates the heat transfer coefficient between the fluid and wall
 - Built-In Code: TD calculates HTC
 - Universal Code: User Subroutine calculates HTC
- 10 Lump/Nodes to match Garrantano test data

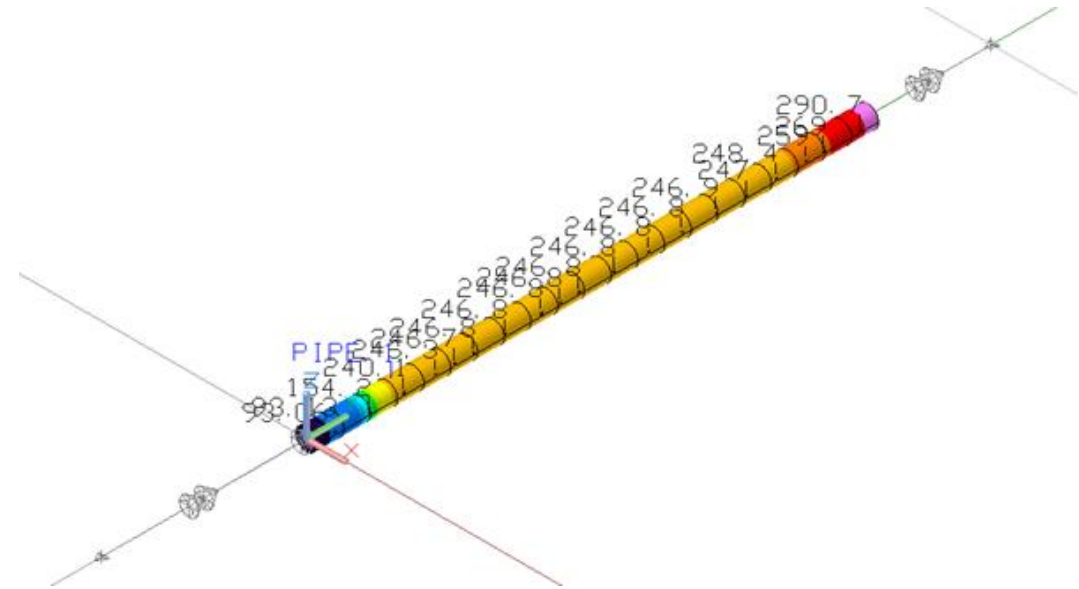

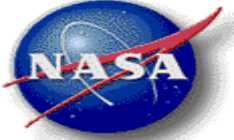

Model Set-Up

- Calculated zCHF vs. Fixed zCHF
 - First Set-Up, Calculated zCHF:
 - Pre-CHF heat transfer coefficients
 - Post-CHF heat transfer coefficients
 - CHF location
 - Second Set-Up, Fixed zCHF:
 - Pre-CHF heat transfer coefficients
 - Post-CHF heat transfer coefficients
 - CHF calculation is FIXED, given as input
 - Not possible to run the Built-In Correlation with a fixed zCHF

- Mean Average Percentage Error (MAPE) = $\frac{1}{n} \sum_{t=1}^n \left| \frac{F_t - A_t}{A_t} \right|$

- Symmetrical Mean Average Percentage Error (SMAPE) = $\frac{1}{n} \sum_{t=1}^n \left| \frac{F_t - A_t}{(A_t + F_t)/2} \right|$

- θ : percentage of data points within +/- 30% of the test data points
- Φ : percentage of data points within +/- 50% of the test data points

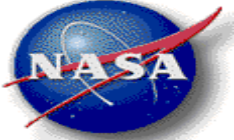

CALCULATED ZCHF MODEL RESULTS

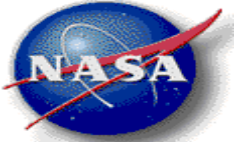

Calculating zCHF Results

Girrantano 1973, LHE, Run Fig 4 Sh 1
Wall Temperature

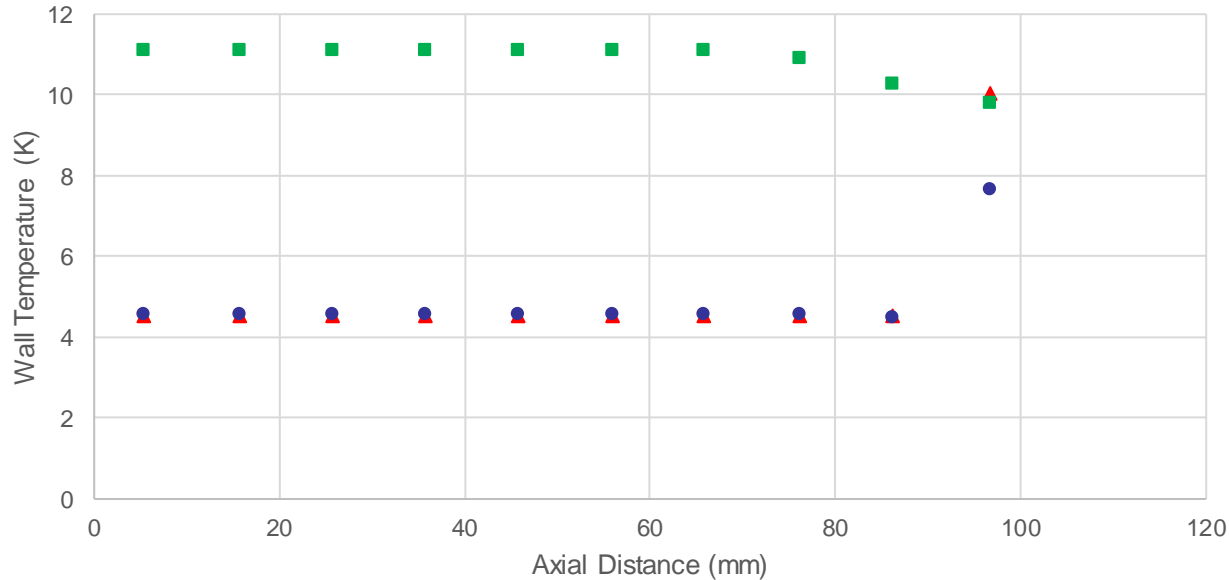

▲ Test Data ● Universal Correlations ■ Built-In Correlations

| Fig 4 Sh 1 | Universal Correlation | Built in Correlation |
|--------------|-----------------------|----------------------|
| MAPE | 3.4% | 129.8% |
| SMAPE | 3.7% | 75.5% |
| zCHF Error % | 8.3% | 96.4% |

Girrantano 1973, LHE, Run Fig 9 Sh 1
Wall Temperature

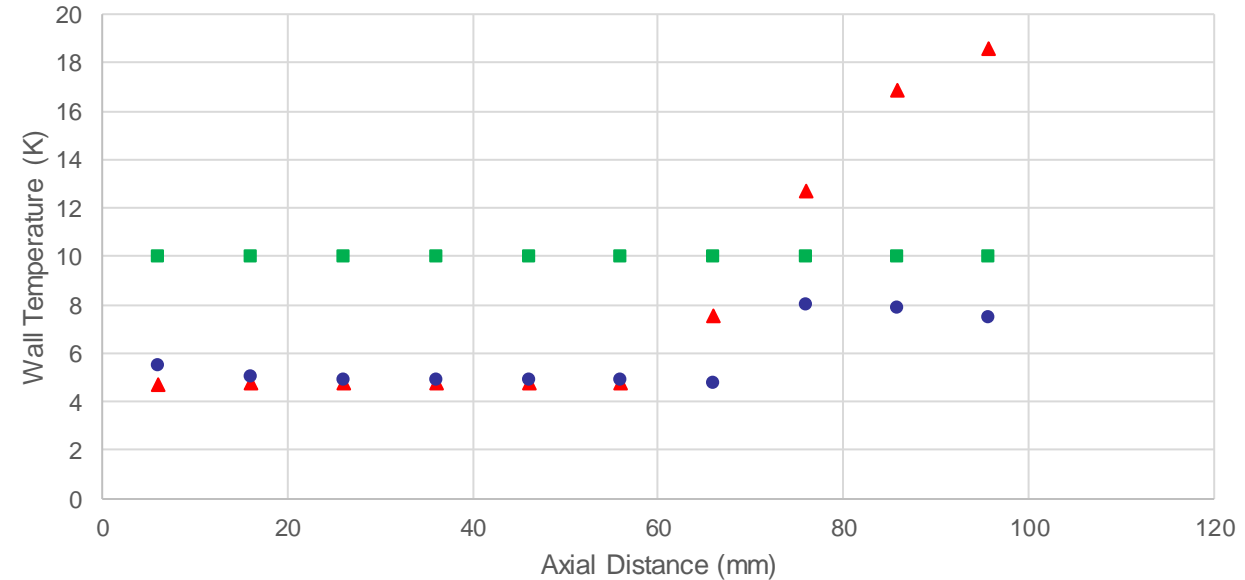

▲ Test Data ● Universal Correlations ■ Built-In Correlations

| Fig 9 Sh 1 | Universal Correlation | Built in Correlation |
|--------------|-----------------------|----------------------|
| MAPE | 21.7% | 80.7% |
| SMAPE | 27.7% | 59.1% |
| zCHF Error % | 4.8% | 96.4% |



Calculating zCHF Results

Girrantano Actual VS Predicted Wall Temperature

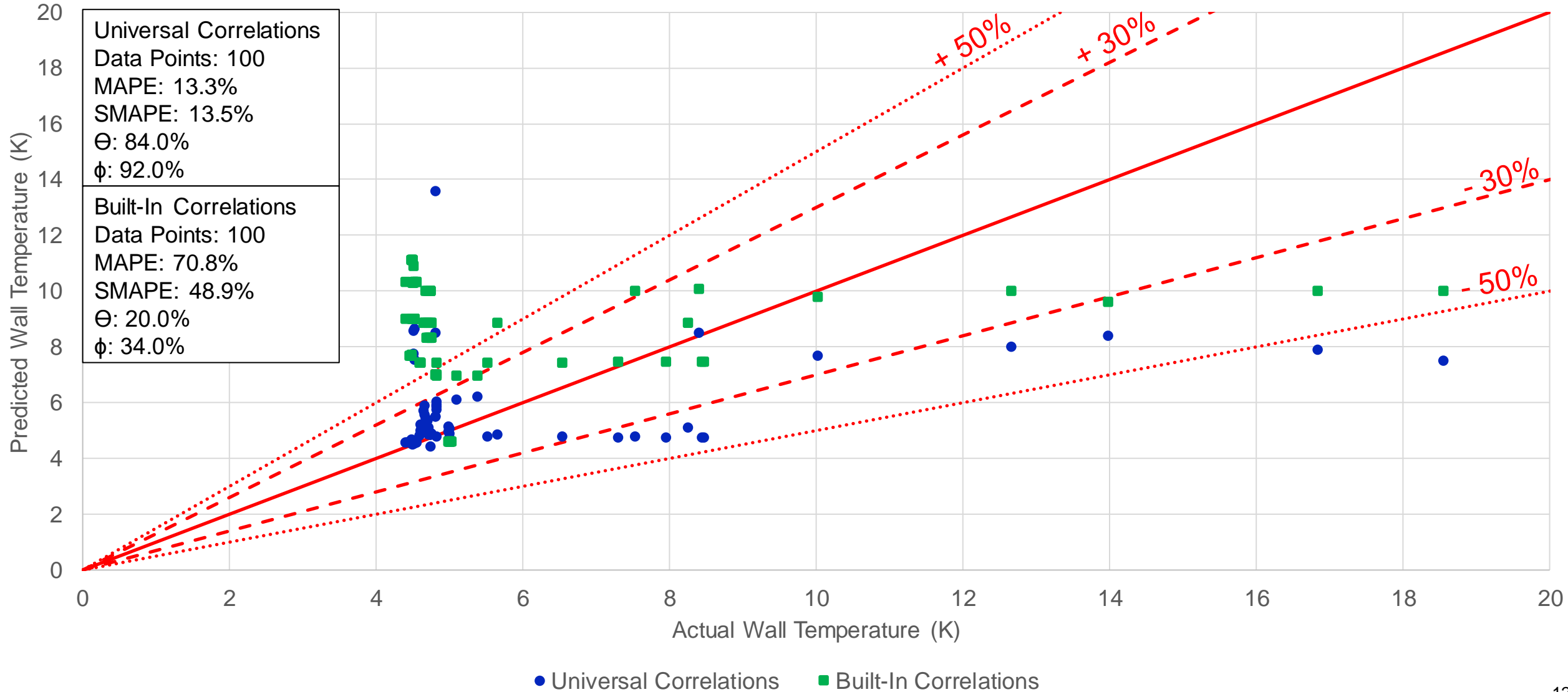

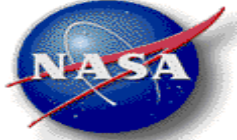

FIXED ZCHF MODEL RESULTS

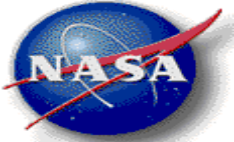

Fixed zCHF Results

Giarrantano 1973, LHE, Run Fig 9 Sh 1
Wall Temperature

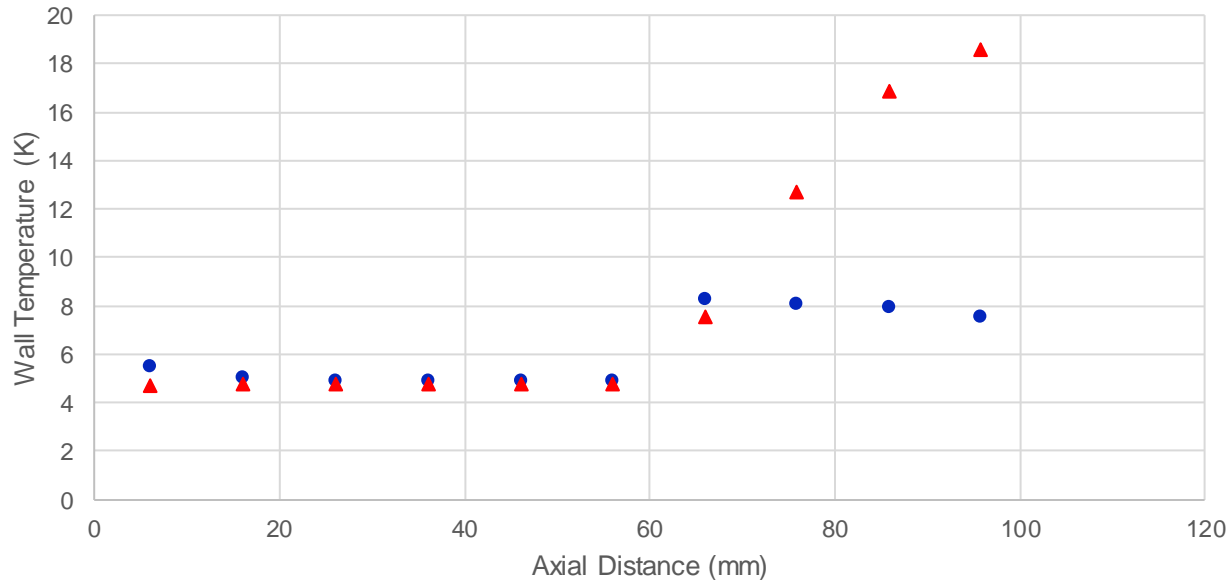

● Universal Correlations ▲ Test Data

| Fig 9 Sh 1 | Overall | Nucleate Boiling | Film Boiling |
|------------|---------|------------------|--------------|
| MAPE | 18.8% | 5.0% | 39.5% |
| SMAPE | 23.8% | 4.8% | 52.5% |

Giarrantano 1973, LHE, Run Fig 8 Sh 2
Wall Temperature

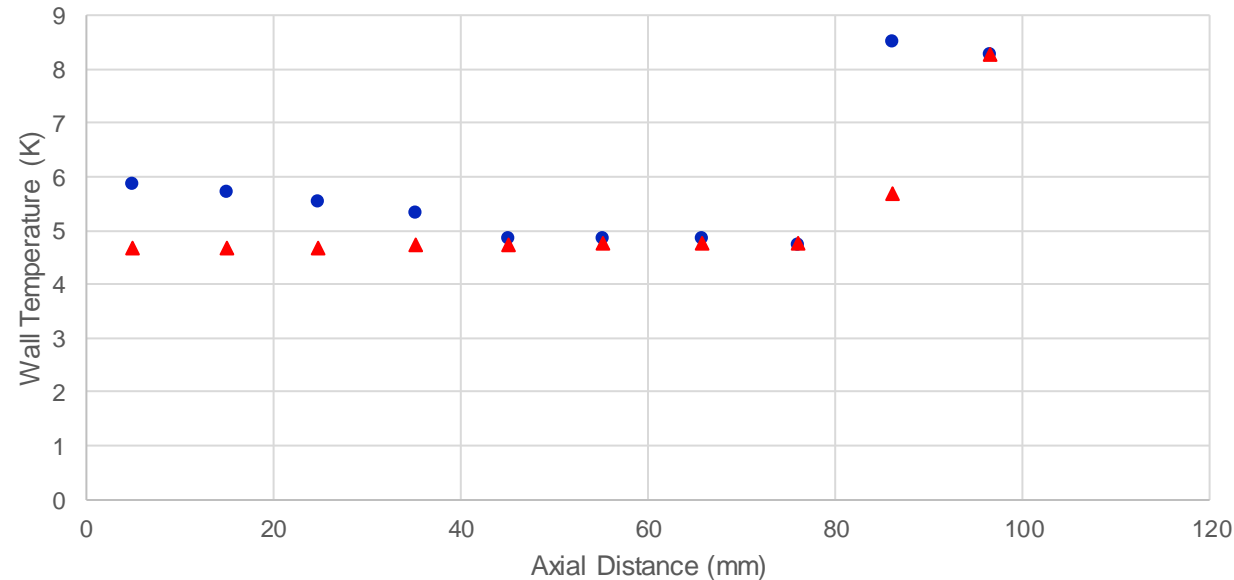

● Universal Correlations ▲ Test Data

| Fig 8 Sh 2 | Overall | Nucleate Boiling | Film Boiling |
|------------|---------|------------------|--------------|
| MAPE | 13.7% | 10.8% | 25.2% |
| SMAPE | 11.9% | 9.9% | 20.2% |

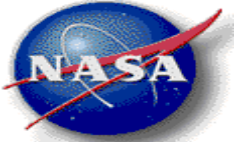

Fixed zCHF Results

Giarrantano Helium Nucleate Boiling
Actual VS Predicted Wall Temperature

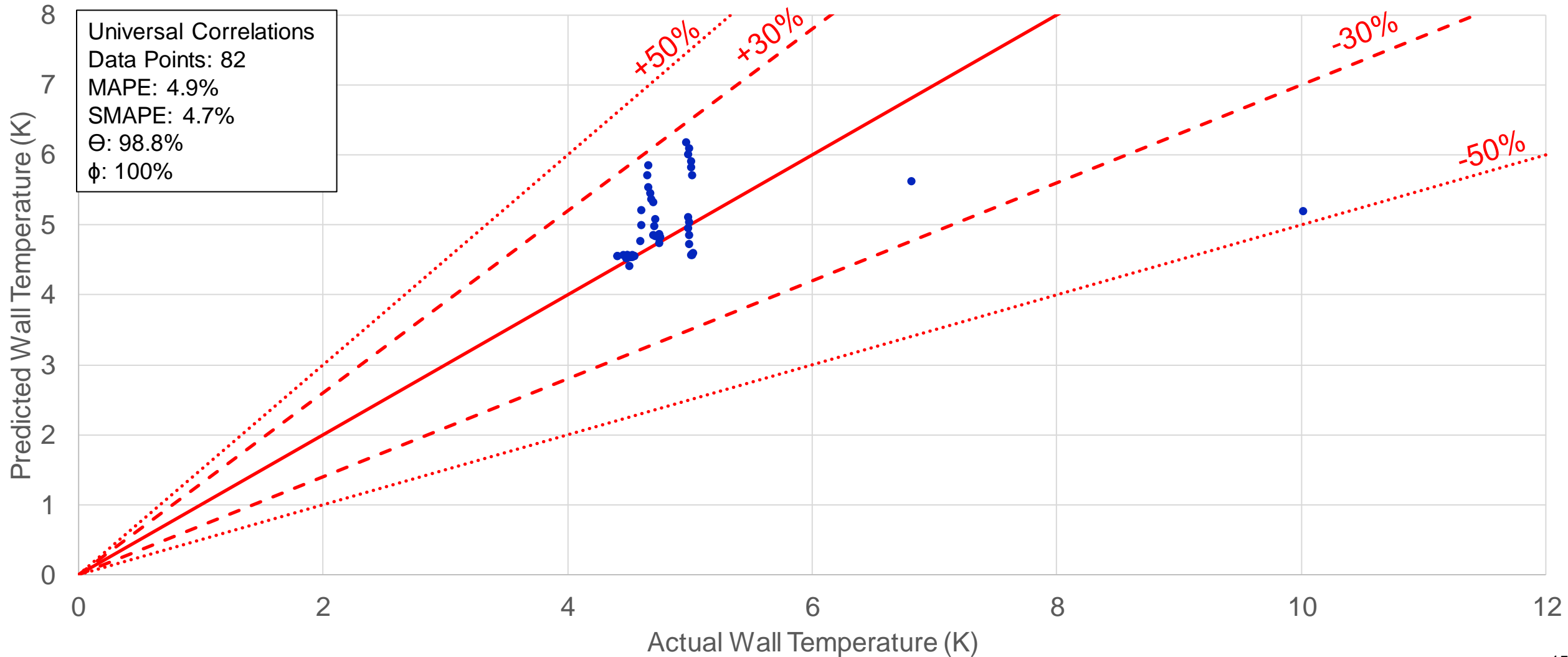

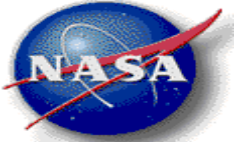

Fixed zCHF Results

Giarrantano Helium Film Boiling
Actual VS Predicted Wall Temperature

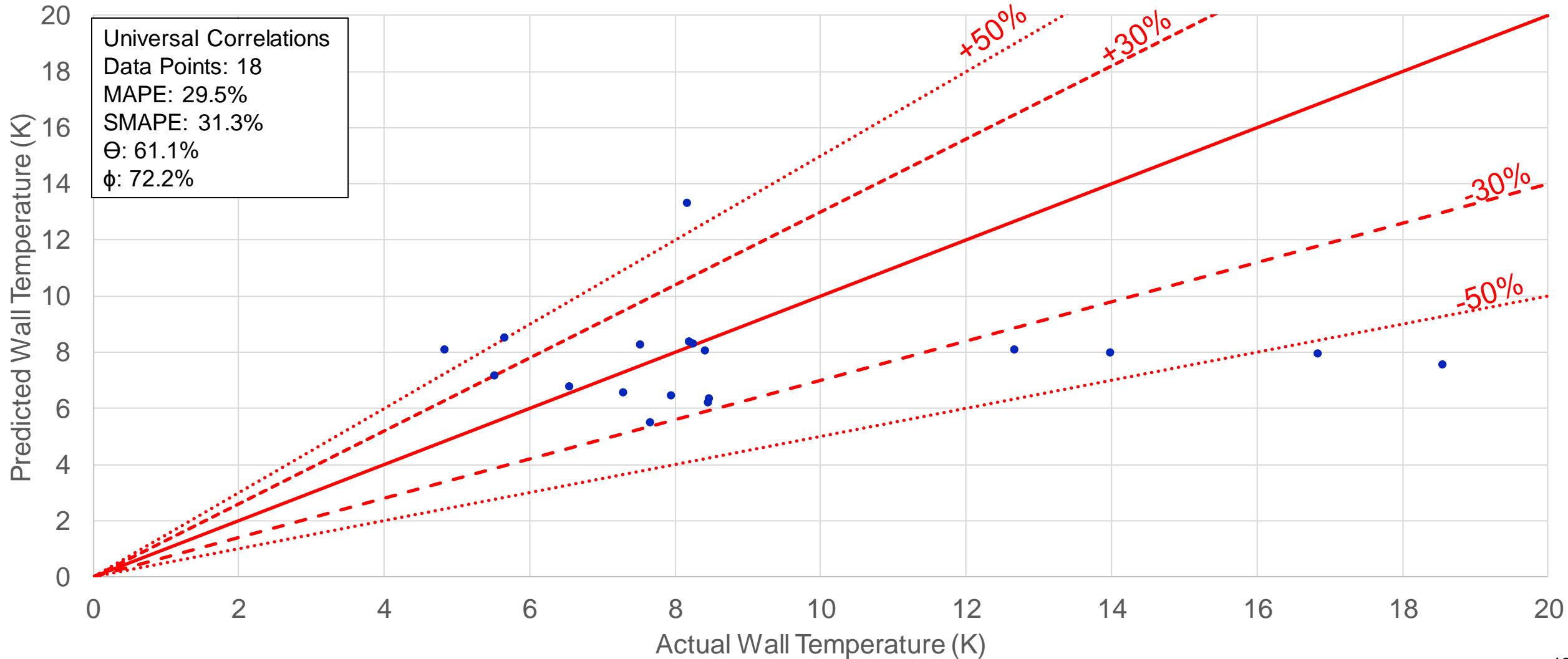

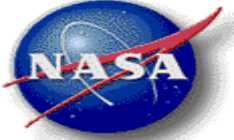

Discussion

- Universal Code outperforms Built-In Code in Calculating zCHF model for Helium
 - Universal Code MAPE/SMAPE < 14%
 - Built-In Code MAPE/SMAPE < 71%
 - Both Built-In TD Code and Universal code underpredict film boiling
- Fixed zCHF model using Universal Code gives MAPE/SMAPE <5% in pre-CHF region
- Fixed zCHF model using Universal Code gives MAPE/SMAPE <32% in post-CHF region
- Future Work:
 - Concurrently evaluating performance of Universal Correlations for other cryogenes
 - Universal Correlations implementation into Thermal Desktop can be used for future experiments to predict transfer line performance

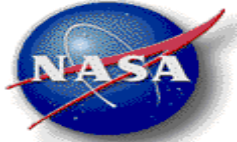

Questions?

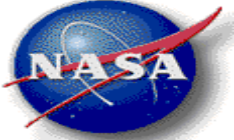

References

C&R Technologies. TD Suite Manual For Thermal Desktop, TD Direct, and SINDA/FLUINT. Version 6.3, Thermal Desktop Patch 13, SINDA/FLUINT Patch 10, 2022.

Baylor, Michael. "Sn4 Becomes First Full-Scale Starship Prototype to Pass Cryogenic Proof Test." NASASpaceFlight.Com, 27 Apr. 2020, www.nasaspaceflight.com/2020/04/starship-sn4-set-for-test/.

Ganesan, V., Patel, R., Hartwig, J., & Mudawar, I. Universal critical heat flux (CHF) correlations for cryogenic flow boiling in uniformly heated tubes. *International Journal of Heat and Mass Transfer*, 166, 120678. <https://doi.org/10.1016/j.ijheatmasstransfer.2020.120678>, 2021.

Ganesan, V., Patel, R., Hartwig, J., & Mudawar, I. Review of databases and correlations for saturated flow boiling heat transfer coefficient for cryogenics in uniformly heated tubes, and development of new Consolidated Database and universal correlations. *International Journal of Heat and Mass Transfer*, 179, 121656. <https://doi.org/10.1016/j.ijheatmasstransfer.2021.121656>, 2021.

Ganesan, V., Patel, R., Hartwig, J., & Mudawar, I. Universal correlations for post-CHF saturated and superheated flow film boiling heat transfer coefficient, minimum heat flux and rewet temperature for cryogenic fluids in uniformly heated tubes. *International Journal of Heat and Mass Transfer*, 195, 123054. <https://doi.org/10.1016/j.ijheatmasstransfer.2022.123054>, 2022.

Giarrantano, P. J., Hess, R.C., & Jones, M.C. Forced Convection Heated Transfer to Subcritical Helium I. Interim Report Prepared for Air Force Aero Propulsion Laboratory, NBSIR 73-322, 1973.

Hartwig, J.W., Ganesan, V., Johnson, A., Mudawar, I., Leclair, A., Tesny, E., Baldwin, M., Majumdar, A., and Mercado, M. "A Continuous Flow Boiling Curve in the Heating Configuration Based on New Cryogenic Universal Correlations" *International Journal of Heat and Mass Transfer* 2024b.

Mercado, M., Wong, N., Hartwig, J. Assessment of two-phase heat transfer coefficient and critical heat flux correlations for cryogenic flow boiling in pipe heat experiments. *International Journal of Heat and Mass Transfer*, 133, pp 295-315, <https://doi.org/10.1016/j.ijheatmasstransfer.2018.12.108>, 2019.

Sempsrott, Danielle. "Kennedy Plays Critical Role in Liquid Hydrogen Tank Development." NASA, 1 Nov. 2021, www.nasa.gov/feature/kennedy-plays-critical-role-in-large-scale-liquid-hydrogen-tank-development.

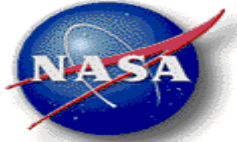

BACKUP SLIDES

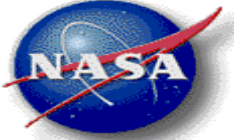

Calculated zCHF model results

| Case | Universal Correlations MAPE (%) | Universal Correlations SMAPE (%) | Universal Correlations zCHF Error (%) | Built-In Correlations MAPE (%) | Built-In Correlations SMAPE (%) | Built-In Correlations zCHF Error (%) |
|-------------------|------------------------------------|-------------------------------------|--|-----------------------------------|------------------------------------|---|
| Figure 3 Sheet 1 | 22.5% | 18.0% | 18.8% | 107.4% | 67.9% | 89.4% |
| Figure 3 Sheet 3 | 14.6% | 11.1% | 21.1% | 99.2% | 66.3% | 100.0% |
| Figure 4 Sheet 1 | 3.4% | 3.7% | 8.3% | 129.8% | 75.5% | 96.8% |
| Figure 5 Sheet 2 | 1.1% | 1.1% | 0.0% | 71.0% | 52.4% | 100.0% |
| Figure 6 Sheet 2 | 5.7% | 6.0% | 0.0% | 8.8% | 9.2% | 100.0% |
| Figure 7 Sheet 1 | 23.1% | 27.9% | 64.3% | 31.5% | 25.8% | 37.1% |
| Figure 8 Sheet 2 | 14.1% | 14.4% | 13.2% | 76.6% | 53.9% | 89.6% |
| Figure 9 Sheet 1 | 21.7% | 27.7% | 5.1% | 80.7% | 59.1% | 68.7% |
| Figure 9 Sheet 2 | 4.1% | 4.0% | 2.7% | 75.3% | 54.7% | 100.0% |
| Figure 10 Sheet 1 | 23.1% | 21.1% | 6.3% | 27.5% | 24.0% | 68.9% |
| Average | 13.3% | 13.5% | 14.0% | 70.8% | 48.9% | 85.0% |

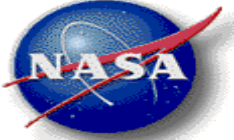

Fixed zCHF Model Results

| Case | Universal Correlations pre-CHF MAPE (%) | Universal Correlations pre-CHF SMAPE (%) | Number of pre-CHF data points | Universal Correlations post-CHF MAPE (%) | Universal Correlations post-CHF SMAPE (%) | Number of post-CHF data points |
|-------------------|---|--|-------------------------------|--|---|--------------------------------|
| Figure 3 Sheet 1 | 1.0% | 1.0% | 8 | 23.7% | 29.7% | 2 |
| Figure 3 Sheet 3 | 0.8% | 0.8% | 10 | - | - | - |
| Figure 4 Sheet 1 | 5.9% | 7.4% | 10 | - | - | - |
| Figure 5 Sheet 2 | 1.1% | 1.1% | 10 | - | - | - |
| Figure 6 Sheet 2 | 5.7% | 6.0% | 10 | - | - | - |
| Figure 7 Sheet 1 | 8.3% | 7.9% | 3 | 26.0% | 24.5% | 7 |
| Figure 8 Sheet 2 | 10.8% | 9.9% | 8 | 25.2% | 20.2% | 2 |
| Figure 9 Sheet 1 | 5.0% | 4.8% | 6 | 39.5% | 52.5% | 4 |
| Figure 9 Sheet 2 | 3.5% | 3.3% | 10 | - | - | - |
| Figure 10 Sheet 1 | 18.7% | 17.5% | 7 | 31.2% | 27.7% | 3 |
| Average | 5.5% | 5.5% | - | 29.5% | 31.3% | - |