



34th Thermal & Fluids Analysis Workshop (TFAWS)

Integrated Modeling – Thermal Perspective

Kuo-Chia (Alice) Liu, Ph.D.

Roman Space Telescope Integrate Modeling Lead

GSFC - Code 592

alice.liu@nasa.gov

Carson McDonald

Roman Space Telescope Integrated Modeling Thermal

GSFC – Code 545, Vertex Aerospace

carson.s.mcdonald@nasa.gov

Note: Reference in this workshop to any specific commercial products, process, service, manufacturer, company, or trademark does not constitute its endorsement or recommendation by the U.S. Government

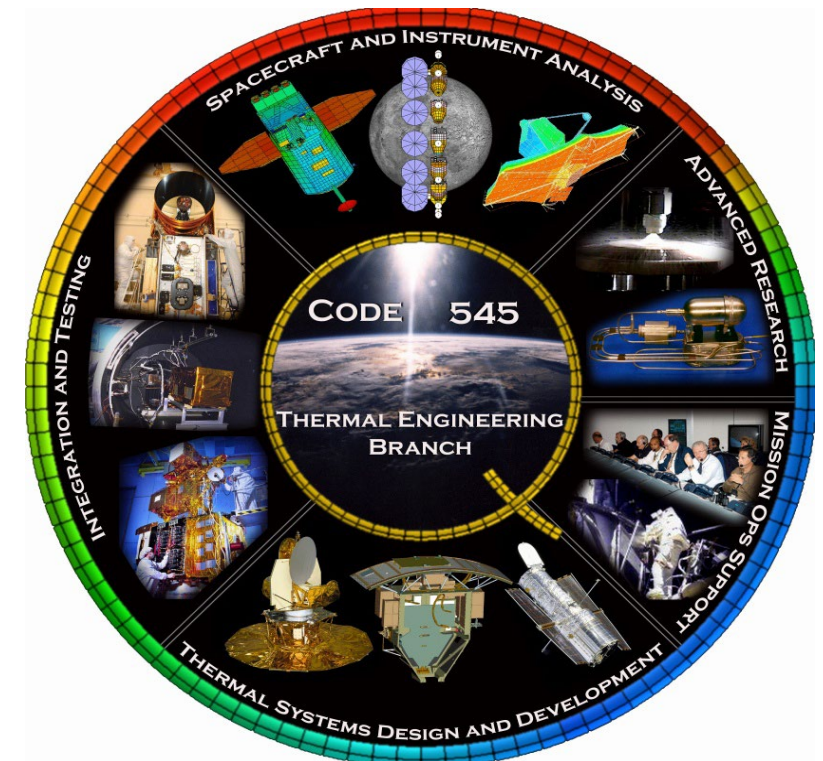



Acknowledgement



- **Presenters would like to acknowledge the Roman IM team and Gary Mosier (JWST IM lead) for their contribution to this presentation package**
 - Michael Akkerman, IM STOP
 - Matt Bolcar, Optical Systems
 - Christine Cottingham: Payload Thermal
 - James Govern, IM Deputy
 - John Hawk: Thermal Systems
 - Joe Howard, Optical Modeling
 - Parker Lin, IM Jitter
 - Carson McDonald, IM STOP Thermal
 - Hume Peabody, Thermal Modeling
 - Carl Blaurock, former IM Lead Analyst



What is Integrated Modeling?

- **IM is a cross-disciplinary analysis, critical to the success of many GSFC missions, including large space telescopes such as James Webb Space Telescope (JWST) and Roman Space Telescope (RST)**
 - Verify performance requirements that cannot be practically verified by test or can only be partially verified by test
 - Provide estimates to support requirement derivation and error budget developments
 - Provide system-level performance predictions to guide hardware design and trades for meeting driving optical stability requirements
 - Support design and performance evaluation of key ground tests
- **IM involves the rigorous application of many Systems Engineering processes to the development and operation (use) of models (i.e. think of the model as “the system”)**
 - Defining analysis assumptions, configurations, and scenarios necessary to satisfy the analysis objectives listed above
 - Managing model verification, uncertainty, and validation activities to support requirement verification by analysis

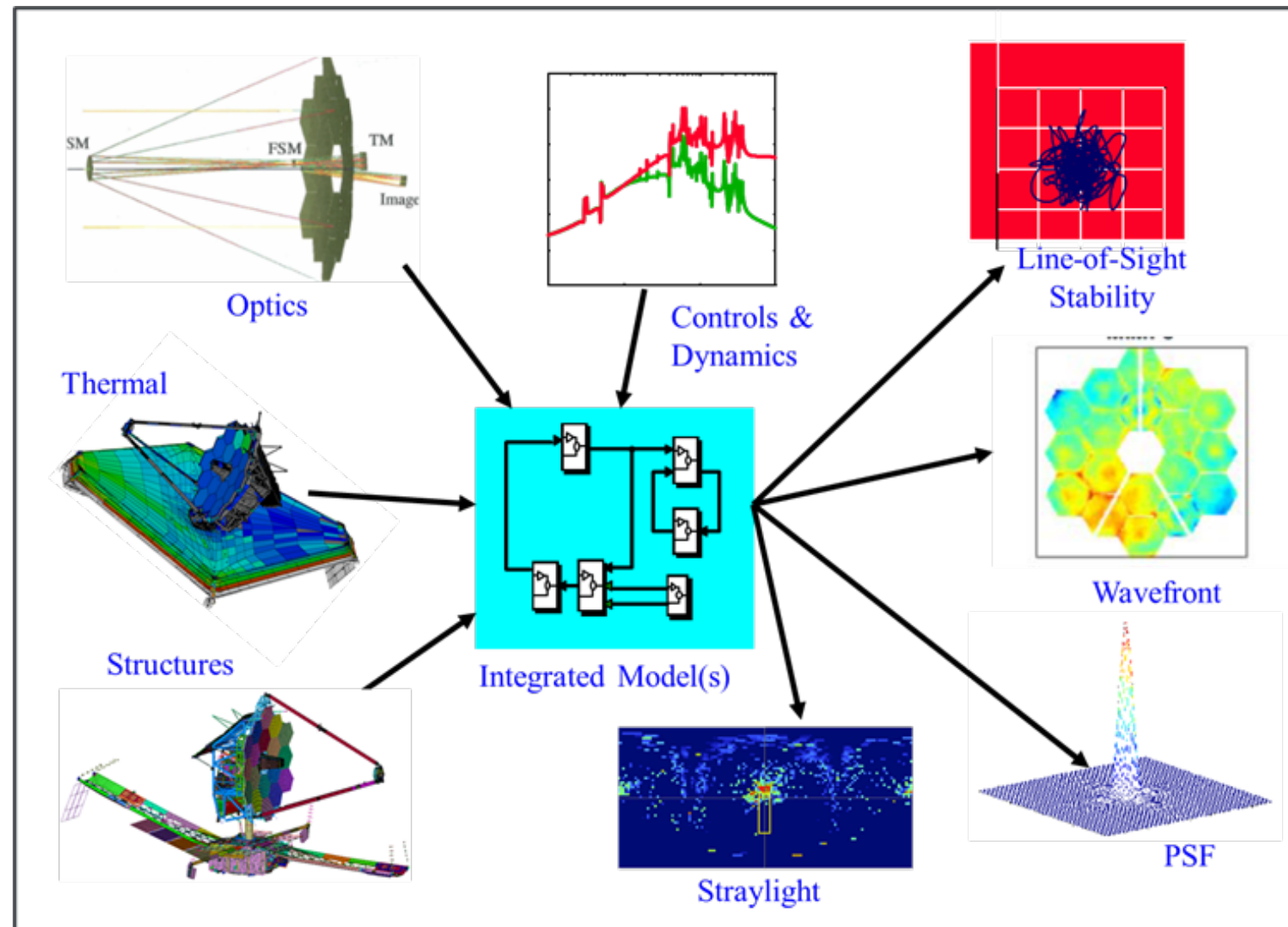



How IM Supports the Mission Lifecycle



Formulation	Implementation	Operations
Define Requirements	Model Correlation	Anomaly Resolution
Trades	Quantify Uncertainties	Re-planning
Sensitivities	Design Verification	On-orbit Calibration
Optimization		
Design Validation		

Keys: Agile/Robust Process, Advanced Analytics, (Near) Real-time Simulation

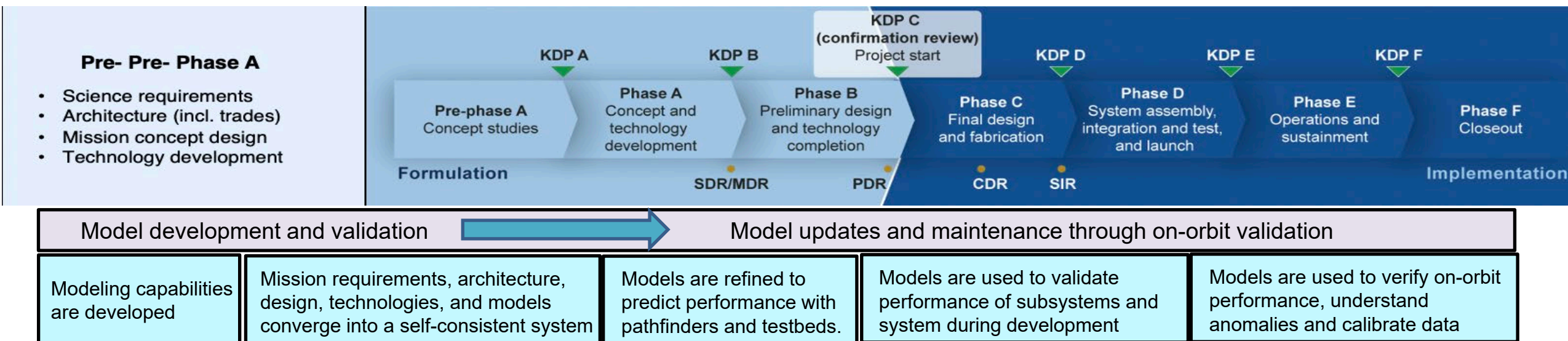



Typical IM Cycle

- **IM leadership includes both managerial and technical responsibilities**

- Coordination of “Vertical Integration” of discipline models, up the supply chain (analogous to H/W I&T)
- Coordination of “Horizontal Integration” of multidisciplinary models
- Scheduling – managing a series of modeling cycles (~6-9 months duration per cycle, depending on complexity of design and model changes)

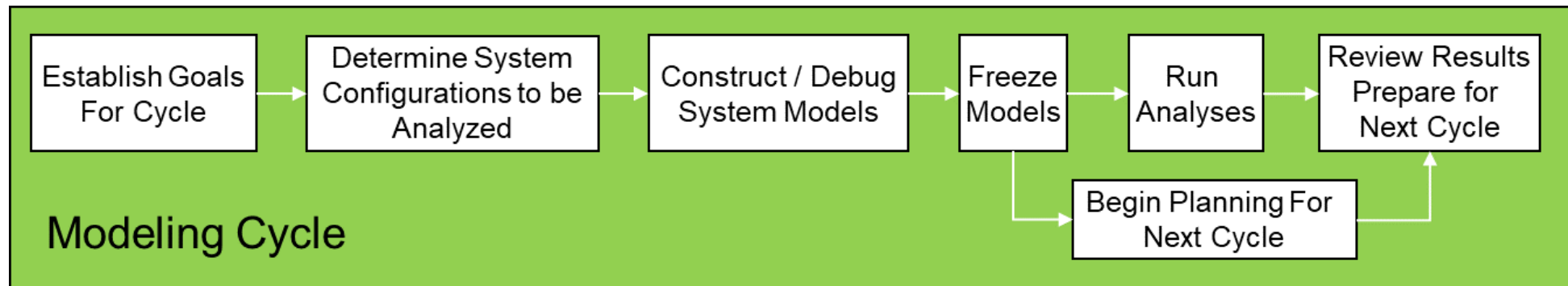

- Establish and maintain standards and requirements for development and use of models

- Math Models Guidelines Document, System Analysis & Model Validation Plan
- Model construction and assembly, including interfaces
- Model verification – Was the model correctly built? Was it correctly used?
- Model validation – Does the model agree with test data, to within some tolerance?
- Configuration management – models, data, documentation

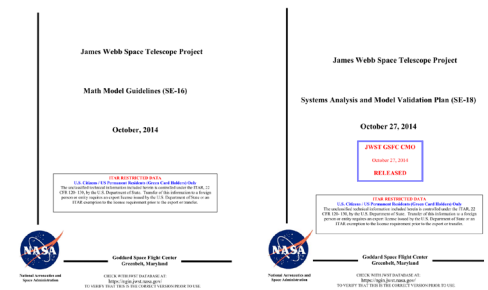



Integrated Modeling Process (JWST Example)

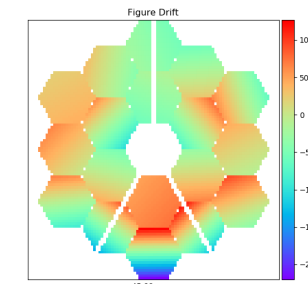
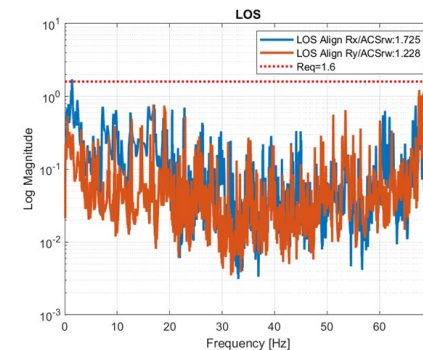
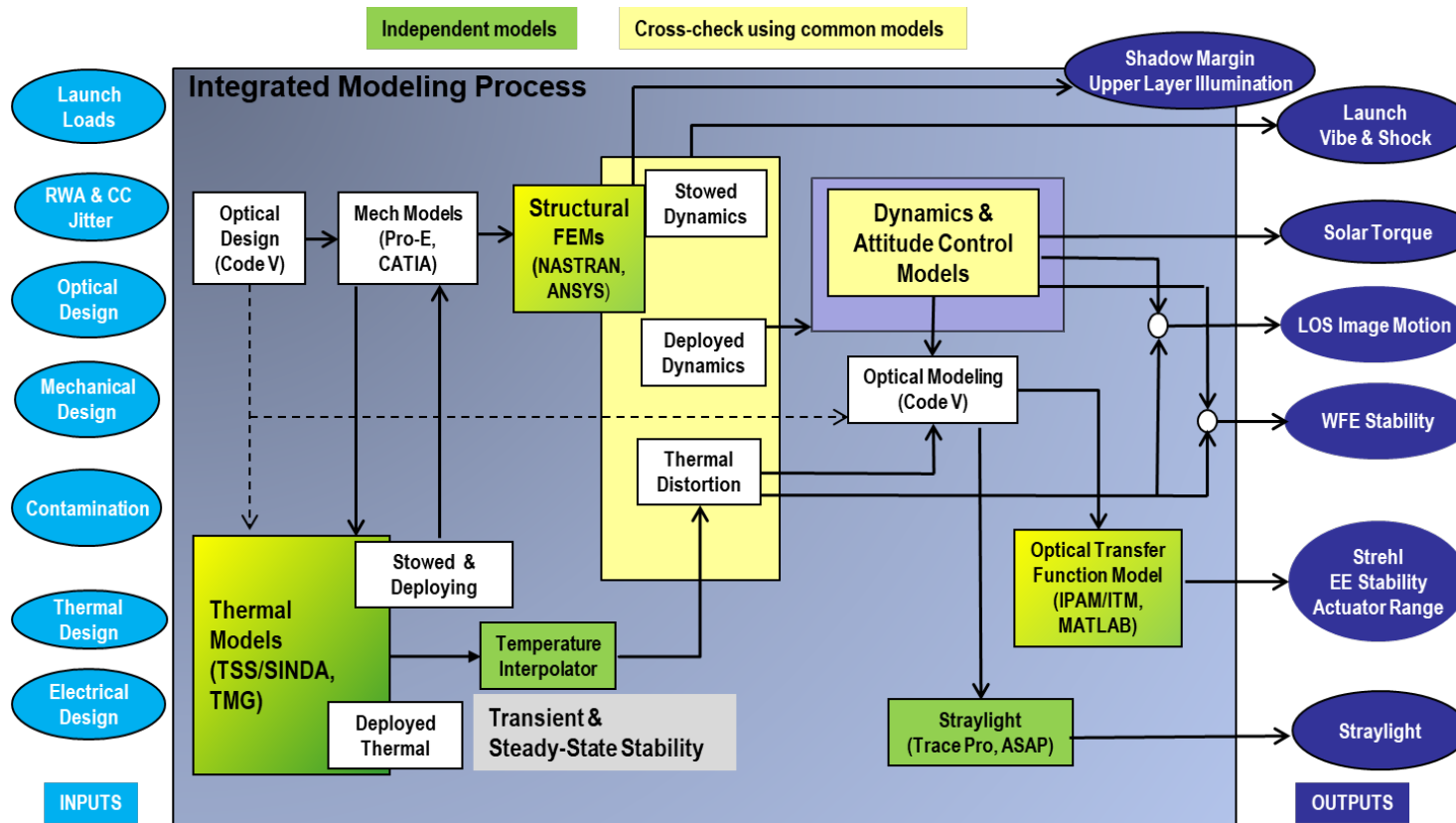
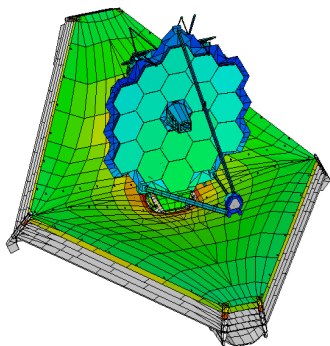
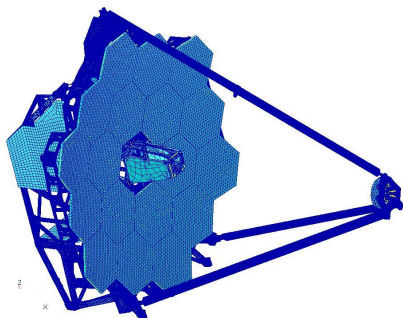
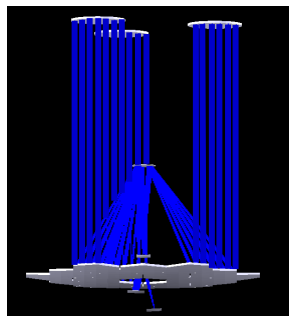

State A: v6c-trHC14_T0 minus
State B: v6c-trHC14_T1209400

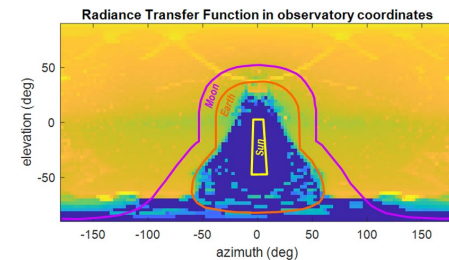



Optics of Imaging Systems

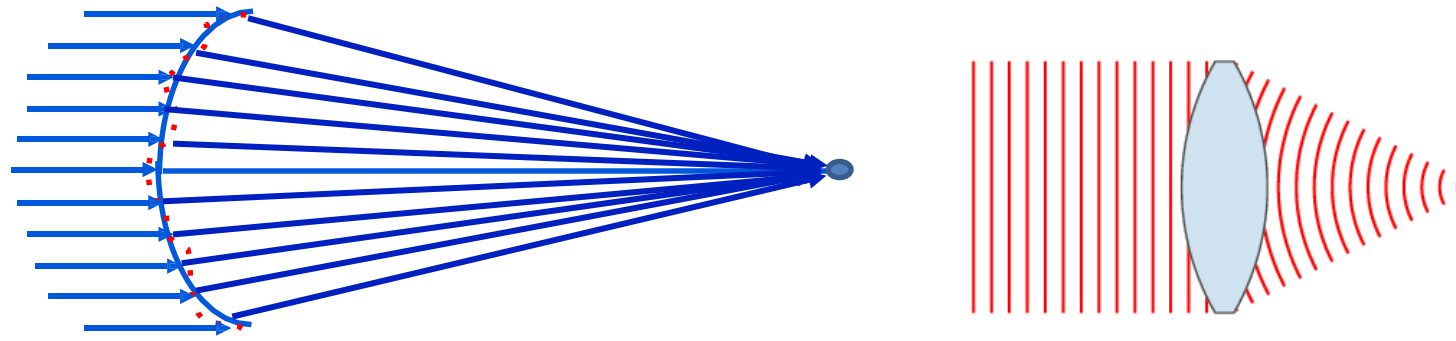

- In a perfect system, all rays appear to converge from a “reference sphere” to a focus
 - Radius of curvature of the sphere is the system focal length (~19m for Roman Wide Field)
- The effect of the finite aperture (limiting diameter of primary mirror) is diffraction, and the resulting point spread function (PSF) of the photons is an Airy distribution
- Physical aberrations in real systems cause the individual rays to arrive at focus out of phase (measured by optical pathlength difference, or OPD, also called wavefront error), resulting in distortions to the PSF
- Line-of-sight (LOS) error results in blurring of the PSF (moving the centroid of the PSF)
- Standard metrics used to characterize performance of imaging systems include:
 - Strehl ratio – ratio of the peak amplitude of the real PSF to that of the ideal PSF
 - Encircled Energy – the integral under the curve of a slice through the PSF core, expressed as a percentage of the total energy, as a function of angular radius

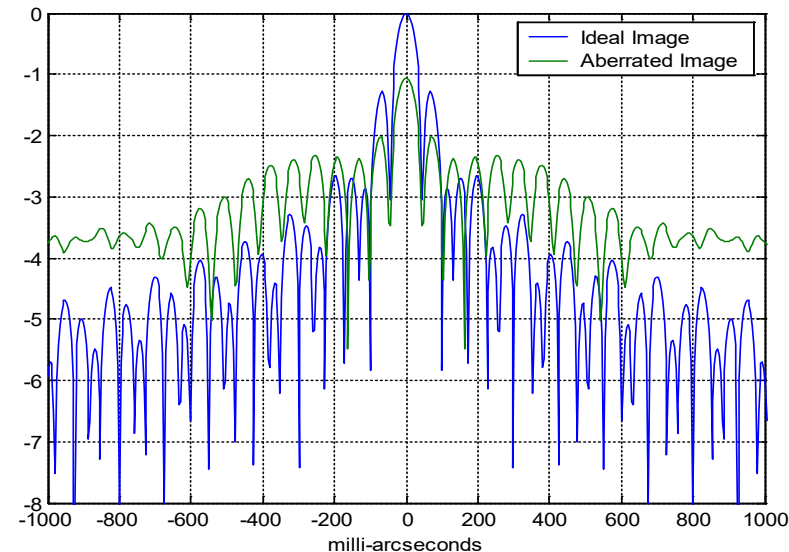
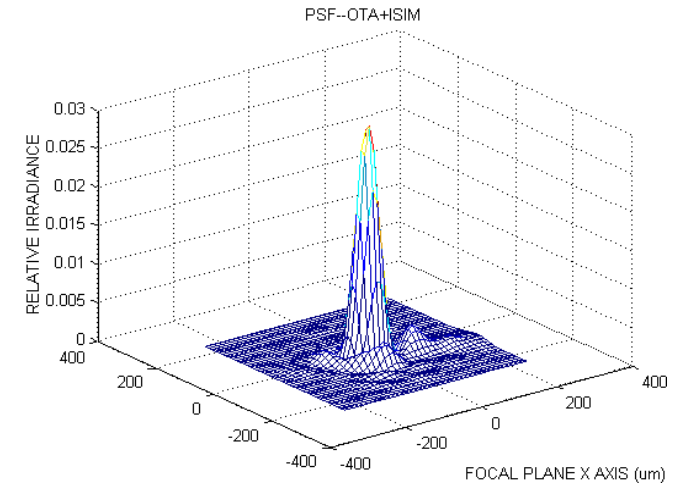



Linear Optical Model and Zernike Polynomials



- **Linear optical model (LOM) derives performance sensitivities from the full optical model**
 - Optical sensitivity data include:
 - Exit pupil wavefront error (WFE) maps
 - Line-of-sight (LOS) motion on the sky
 - Reference Ray motions at optical surfaces of interest
 - Sensitivities are calculated due to changes in:
 - Alignment: rigid body motions (i.e. 6 DOF movements)
 - Figure: surface figure error “bending”, low order Zernike polynomials
 - LOM supports Integrated Modeling efforts (Jitter, LOS, and WFE analysis), as well as end-to-end system level modeling
- **Zernike polynomials is a method to decompose a dataset on a circle by using an orthonormal basis function**
 - They are useful for fitting wavefront data and decompose WFE into terms that illustrate the form of deviations
 - LOS is “tip and tilt” terms of the Zernike polynomials.

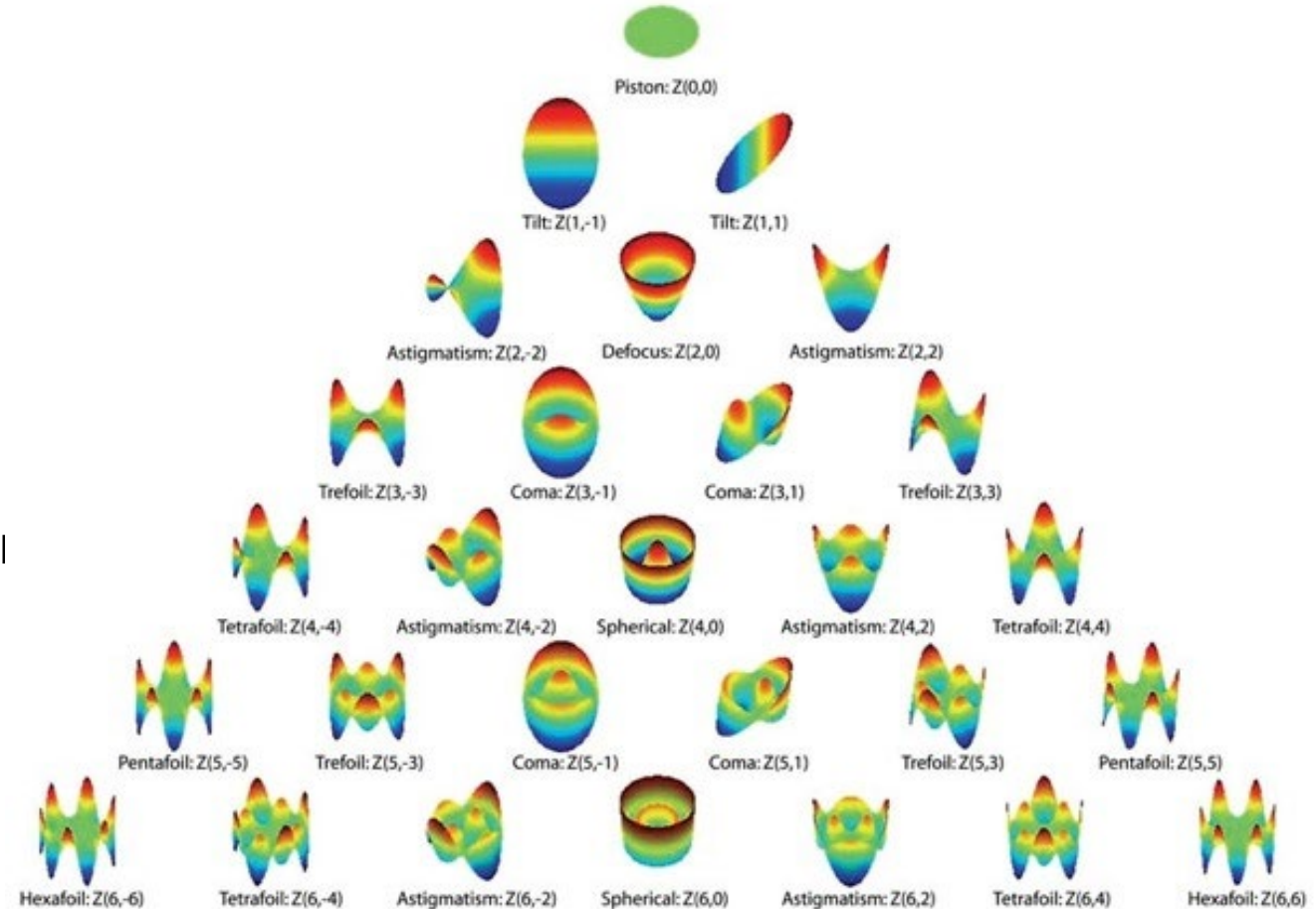

[Zernike Polynomials](#)



Jitter (or Micro-vibration) Analysis Introduction



- **Jitter is motion of the optical beam caused by motion of the optics due to**
 - Mechanism disturbances (reaction wheels, stepper actuators, cryocoolers, etc.)
 - Control system imperfections (actuator and sensor noise) associated with active optics
- **Jitter is a system-level problem and can be managed more effectively by a multi-disciplinary team**
 - “Understanding and managing spacecraft jitter is a highly multi-disciplinary task” – Gary Hendersen (Aerospace Corporation)
- **Combinations of design tools are used to develop the most cost-effective strategies to mitigate jitter concerns**

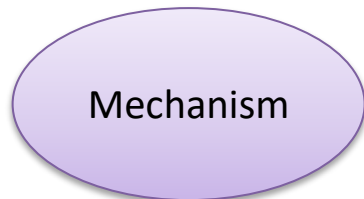

Lower disturbance inputs

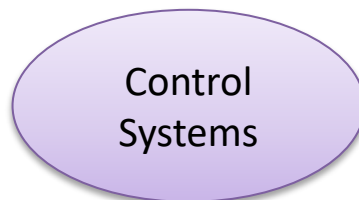

Compensate low-frequency errors

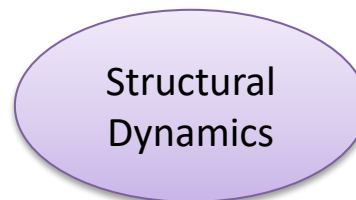

Reduce dynamic responses

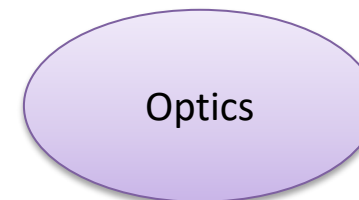

Active optics



Avoid operating mechanisms during observation



STOP Analysis Introduction

- **STOP = Structural Thermal Optical Performance**

- Thermal model captures temperature changes due to cooldown (factory-to-orbit) and on-orbit operation (slews)
- Temperature changes applied to structural FEA model generate displacements and rotations of mirrors and other critical structural components
- Structural model outputs (displacements/rotations) are superimposed upon nominal positions/orientations of mirrors in the optical ray-trace model
- Optical analysis is performed either by using a linear optical model (LOM) or full ray-trace model (Code V or Zemax) to provide optical performance metrics

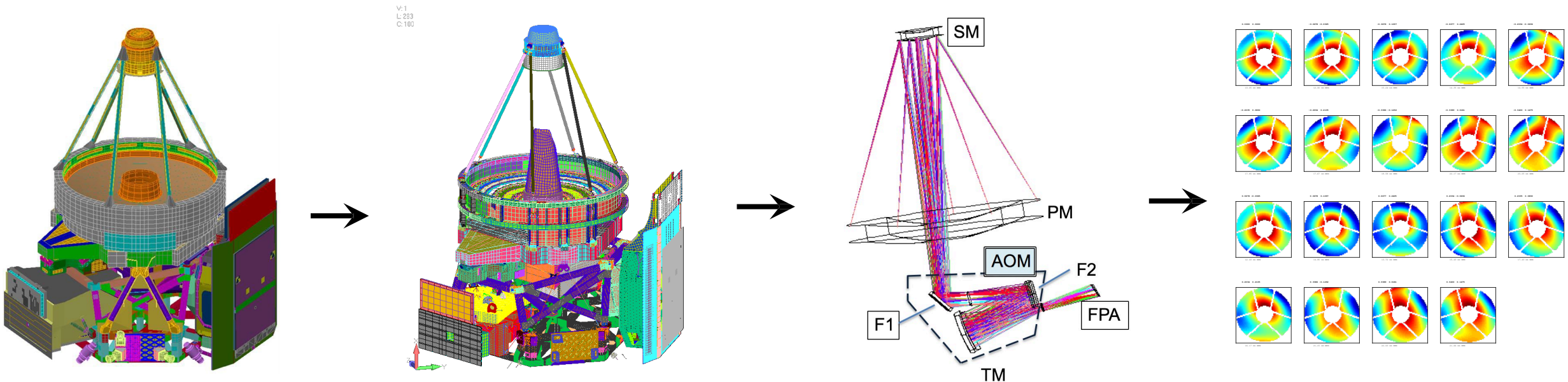



STOP Requirement Flowdown



- **Image quality or wavefront error (WFE) requirements can be sub-allocated to different components via an optical error budget**
 - Optical error budget is typically an “RSS” budget
 - This approach is often conservative since the end-to-end system has internal cancellation, not captured by RSS budgeting
- **IM provides optical predictions due to various distortion effects to validate error budget**
- **IM also generates optical sensitivities to 6DOF mechanical motion and temperature variation which can be used to flow mechanical alignment and temperature requirements**

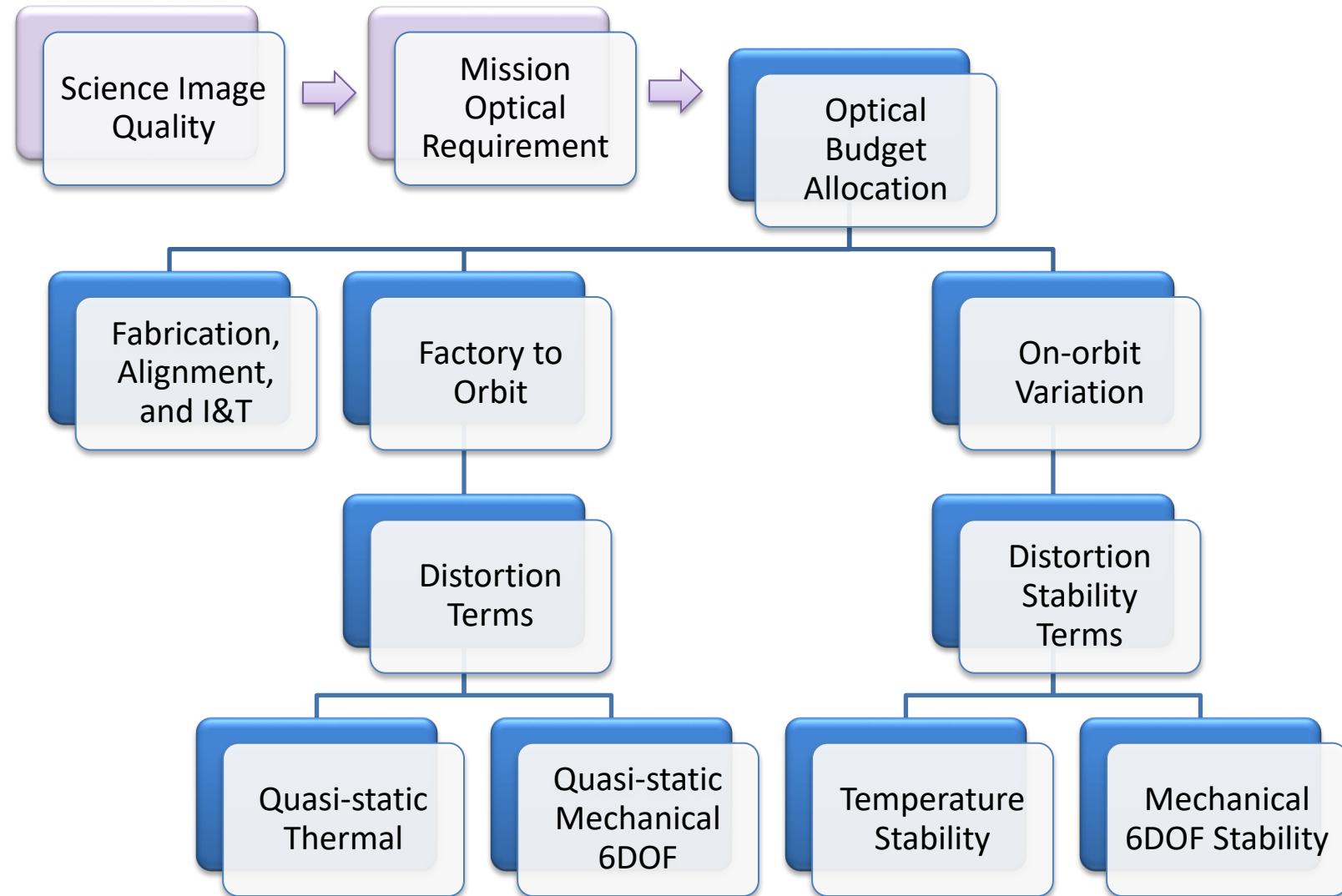



Nancy Grace Roman Space Telescope (Roman) Integrated Modeling



Roman Mission Overview



- **RST:** Nancy Grace Roman Space Telescope (Class A)
- **Mission:** Wide-Field Infrared Survey
- **Objectives:**
 - Determine the nature of the dark energy that is driving the current accelerating expansion of the universe
 - Perform statistical census of planetary systems through microlensing survey
 - Survey the NIR sky
 - Provide the community with a wide field telescope for pointed observations
 - Fly a technology demonstration of a high-contrast coronagraph instrument

- **Mission Duration:** 5 years science
- **Orbit:** Quasi-Halo Orbit about Sun-Earth L2
- **Launch Vehicle:** Falcon Heavy
- **Launch Site:** Eastern Range
- **Mission Budget:** \$3.3 Billion through Phase E
- **Mass:** 10,750 kg (NTE)
- **LRD:** October 2026

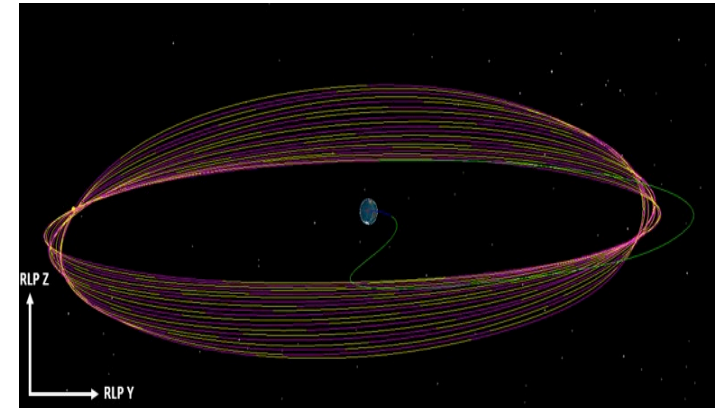

VIEW FROM EARTH TO L2

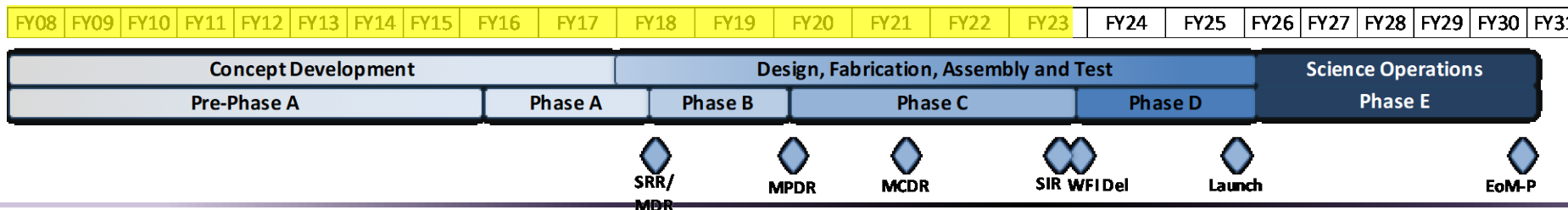
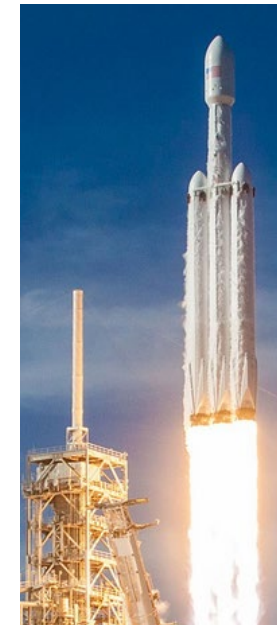
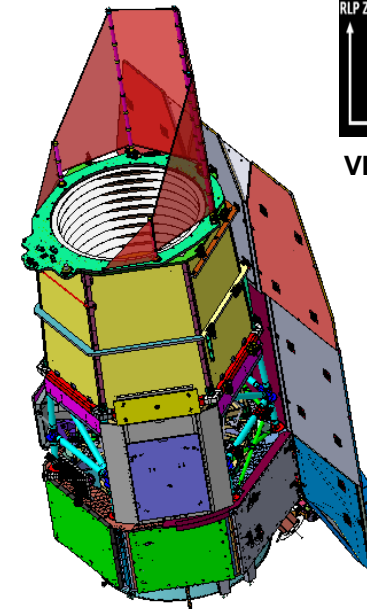



Roman Observatory Overview

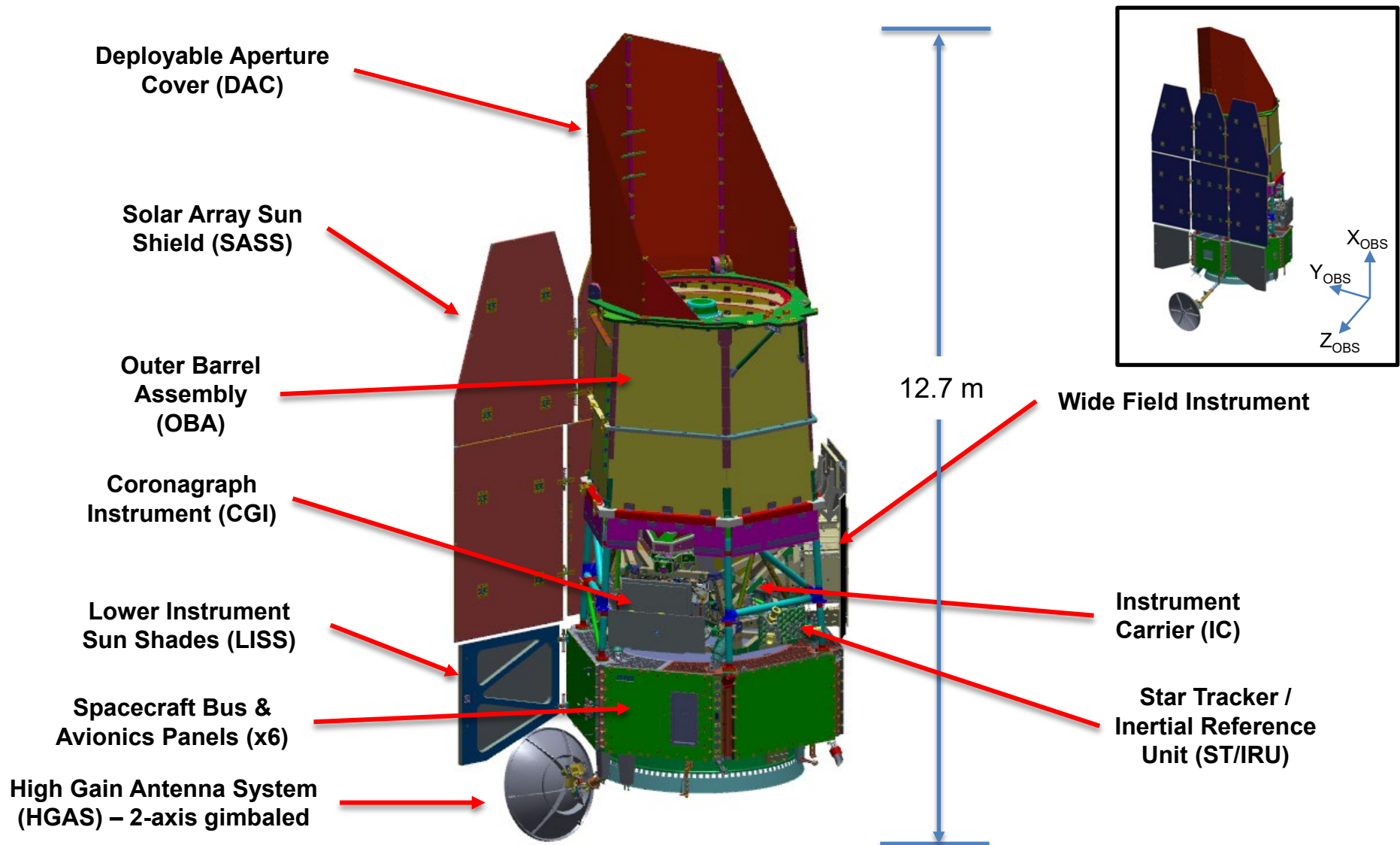



Roman Major Dynamics Error Sources



- **Reaction Wheel Assemblies (RWAS)**
 - Six Honeywell HR18-250 RWAs
 - Fine balance option for reduced static/dynamic disturbance
- **High Gain Antenna System (HGAS)**
 - Two axis gimbal using low-detent stepper motors to provide gimbal pointing
 - The antenna **rarely would need to be moved during imaging**
- **WFI Element Wheel (EW)**
 - Stepper motor used to place the desired optic into the light path
 - **Will not operate during imaging**
- **CGI Fast Steering Mirror (FSM)**
 - Reaction compensated tip/tilt mirror
 - **Self-induced disturbance, managed by CGI**
 - Note: much less contribution from other, smaller mechanisms (Focus and DMs)

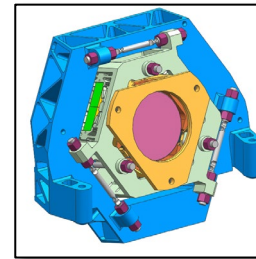

CGI Fast Steering Mirror

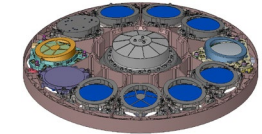

WFI Element Wheel

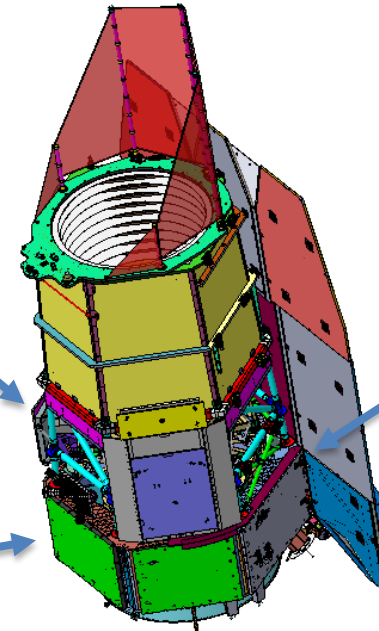

RWAs

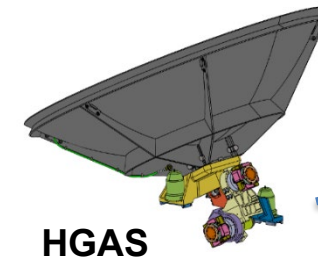
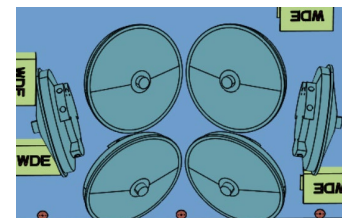

HGAS
(two gimbal actuators)



Roman Examples of Dynamics Mitigations



- **Passive vibration Isolation system between Spacecraft (SC) and Payload**
 - Launch Loads and Vibration Isolation System (LLVIS)
- **Passive vibration isolation systems at disturbance sources**
 - Each reaction wheel assembly (RWA) is individually isolated
 - RWA speeds are limited to reduce disturbance amplitude
- **High Gain Antenna System (HGAS) or stepper motor jitter mitigation implementations**
 - Boom jitter damper damps out HGAS boom modes excited during HGAS operation
 - Actuator microstepping; 16 micro-steps per every detent step
 - HGAS step avoidance during inertial hold
 - Attitude Control System designed their HGAS pointing algorithm and slew profile to minimize the need to step during imaging
- **Solar Array Sun Shield (SASS) Tuned Mass Dampers (TMDs)**
 - Damps out SASS modes excited during wheel and HGAS operations

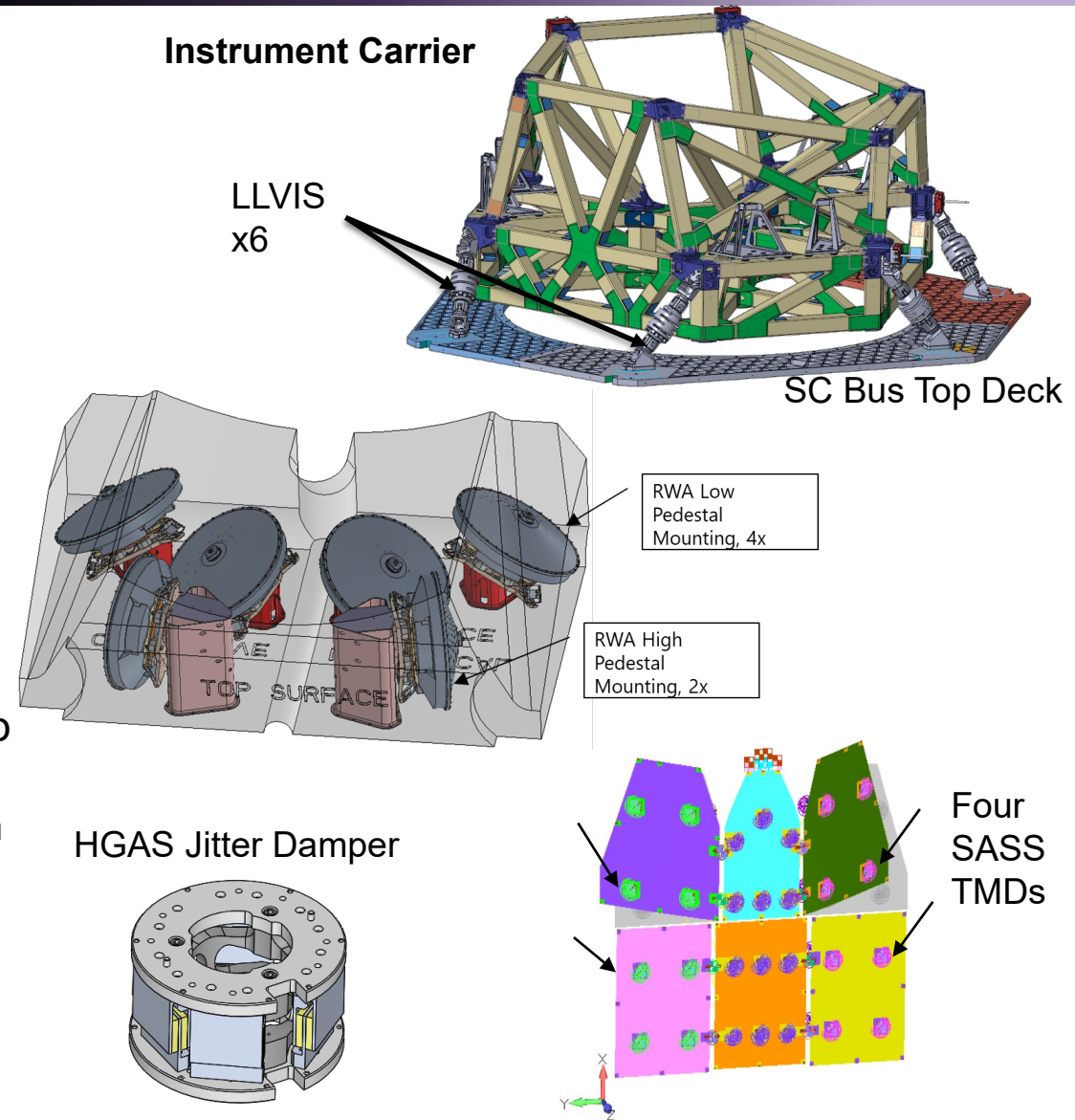



Thermal Impacts on Jitter Performance



- **Passive vibration isolation systems (VIS) and dampers are sensitive to temperature range and variations**
 - Level of sensitivity depends on damping material used in design
 - High: viscoelastic material
 - Mid: fluid
 - Low: magnetic
 - Thermal design must meet VIS temperature range requirements as environment changes, while dissipating heat from disturbance sources
- **Thermal straps and blankets may inadvertently short VIS**
 - “Soft” structure (e.g. harnesses, heat straps, blankets, grounding straps, etc.) in parallel with VIS creates another mechanical path that transmits disturbances from mechanisms to optical payload
 - If blankets (becoming taught at cold) and heat conducting straps are stiffer than the VIS, they create a mechanical short and severely degrade VIS performance

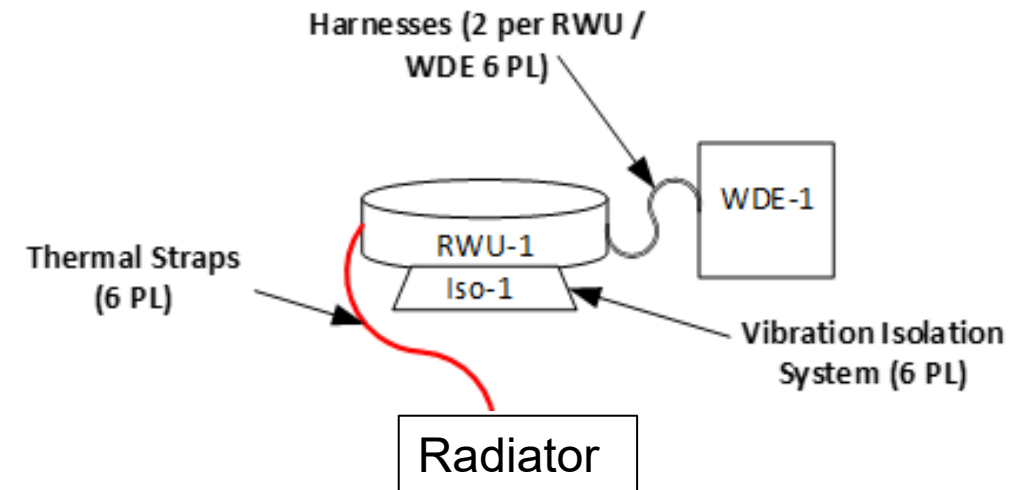
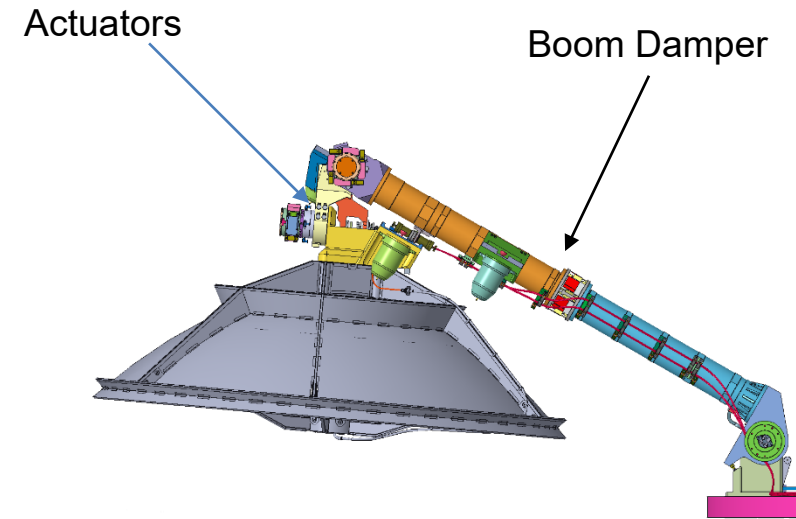



Jitter Analysis Flow

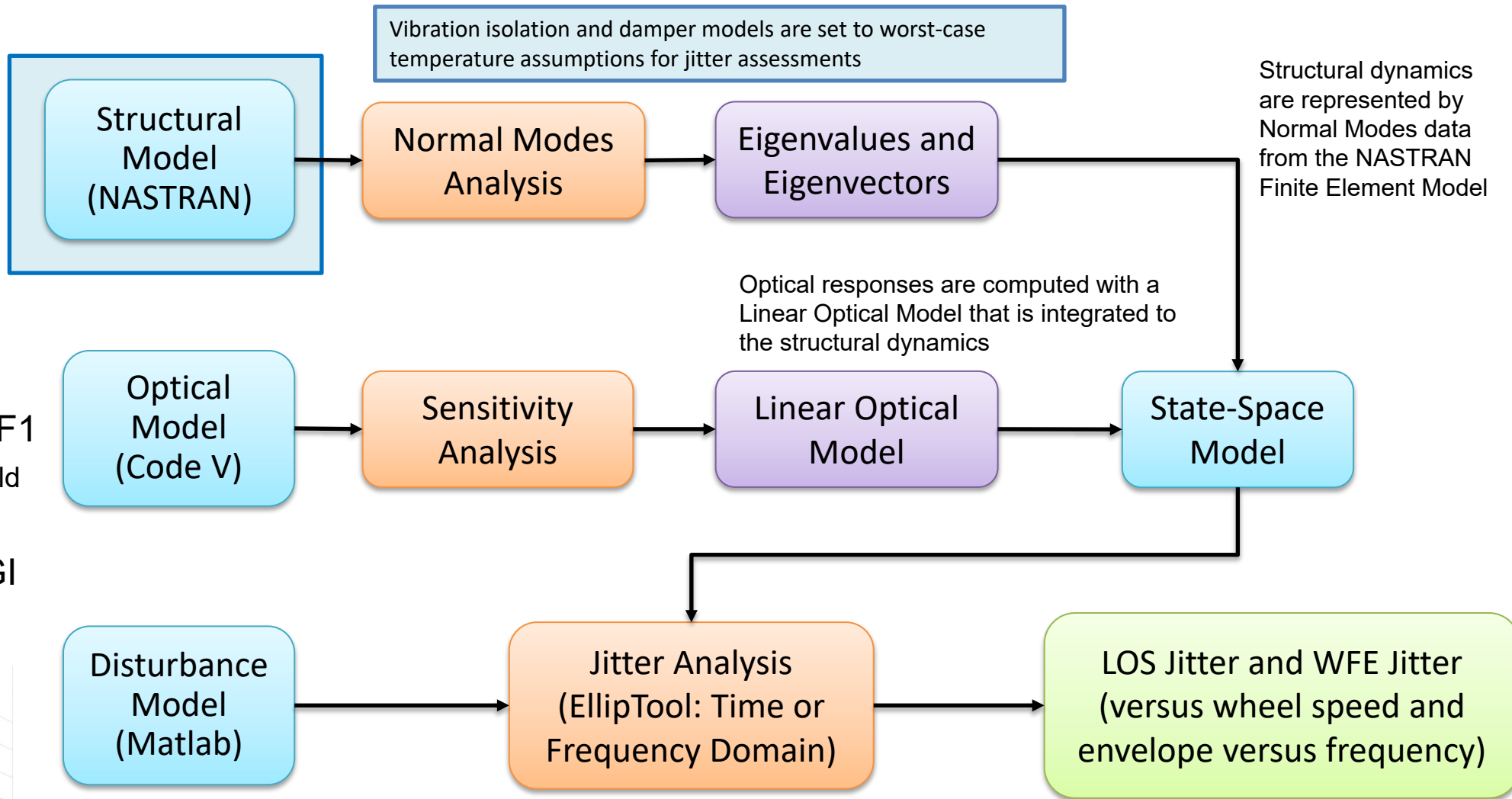
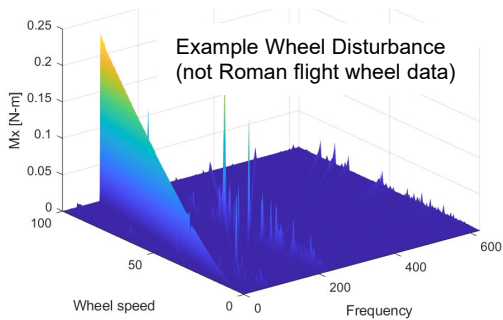
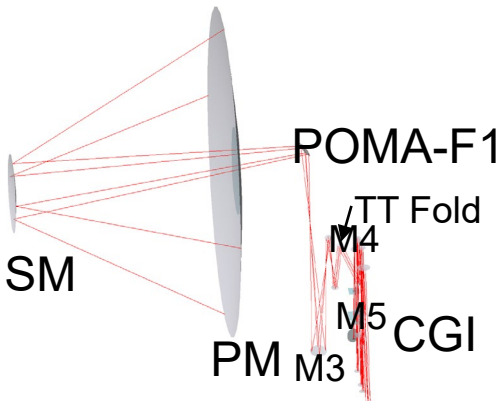
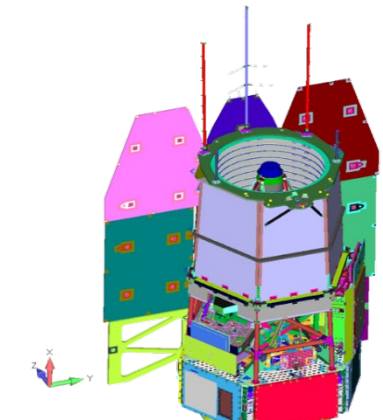

Frequency domain (reaction wheel, facility noise) and time domain (stepper mechanism) disturbances are impinged on the integrated model to produce optical response predictions



Stability Perturbations and Mitigations

Structural-Thermal-Optical (STOP) and Distortion



Perturbations

- **Ground to orbit**
 - Cooldown
 - Gravity release
- **On-orbit variations**
 - Thermal due to change in environment
 - Thermal due to internal heat load variations
 - Hygroscopic dryout
 - Invar growth
 - Beginning-of-life to end-of-life material property changes

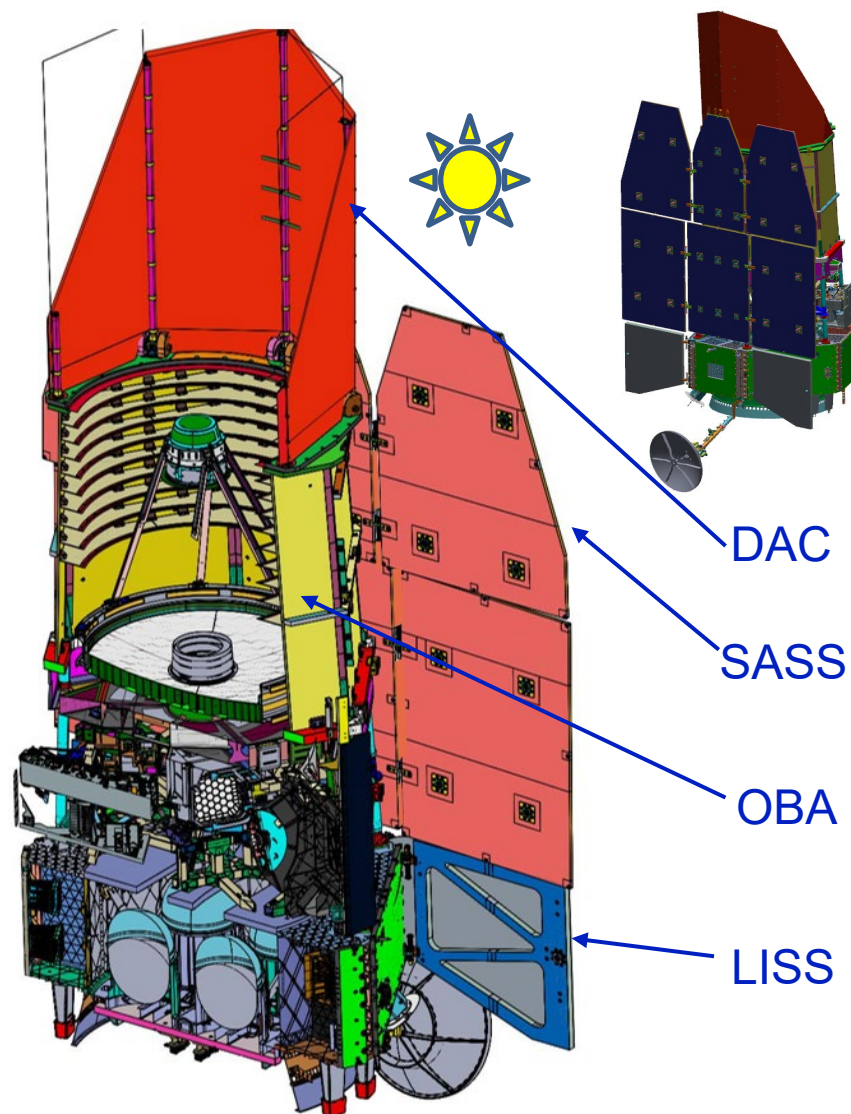

- **Ground-to-orbit**
 - Place optics at predicted 1G and warm positions to offset gravity and cold-shift effects
 - Cold figure primary mirror
 - Thermal control system
 - Kinematic interfaces (FOA struts and WFI outer enclosure)
 - Flight Alignment compensators
- **Thermal/Thermoelastic Stability**
 - Mechanical sun shields
 - Deployed Aperture Cover (DAC)
 - Solar Array and Sun Shield (SASS)
 - Outer Barrel Assembly (OBA)
 - Lower Instrument Sun Shade (LISS)
 - Thermal control systems
 - OBA, IOA, IC, WFI, CGI, and Spacecraft Bay 4
 - Active optics control
 - CGI focus mechanism and deformable mirrors
 - Operational constraints
 - Reduce slew size and observing plans
- **Long-term material and/or dimensional stability**
 - Flight alignment compensators



Roman Thermal Control Architecture for Operational Scenarios



- **Payload elements have PI (PID with D set to 0) heater control systems**

- Both WFI and CGI instruments have input current/voltage implementation
- OTA has hardware-based PWM implementation
- IC has software-based PWM implementation

- **Optical Barrel Assembly (OBA) thermal control baselined with software-based PWM**

- **Recently changed Spacecraft Bay 4 from bang-bang to PI PWM**

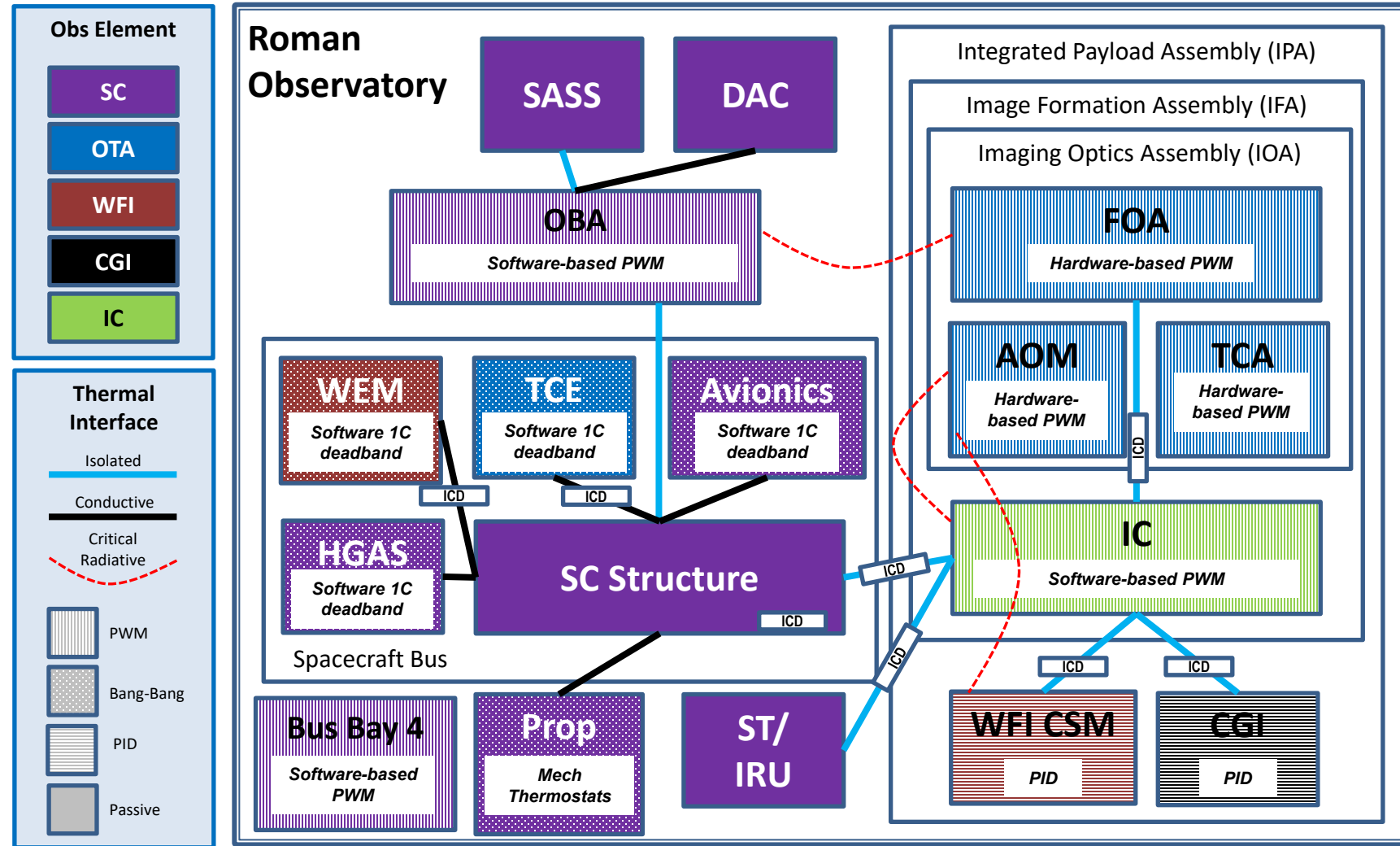



Roman Structural-Thermal-Optical (STOP) Analysis Flow



CGI Observational Scenario (OS)

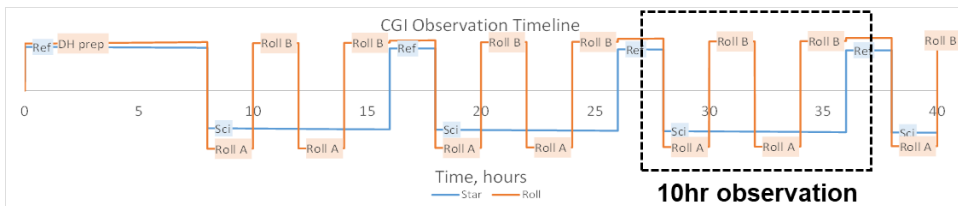

- CGI OS11 Includes both external (e.g. sun angle) and internal (e.g. electronics dissipation) disturbances

Temperature Predicts (Thermal Desktop)

Disturbances

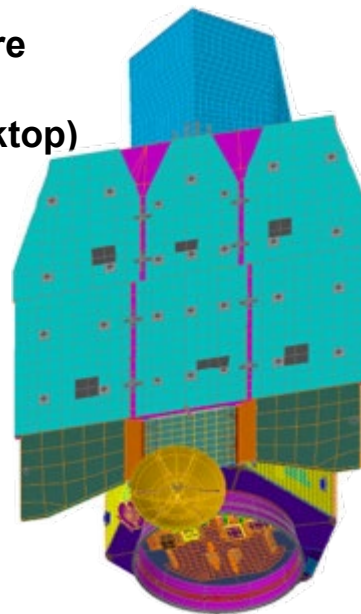

Temp. Map

Structural Deformations (Nastran)

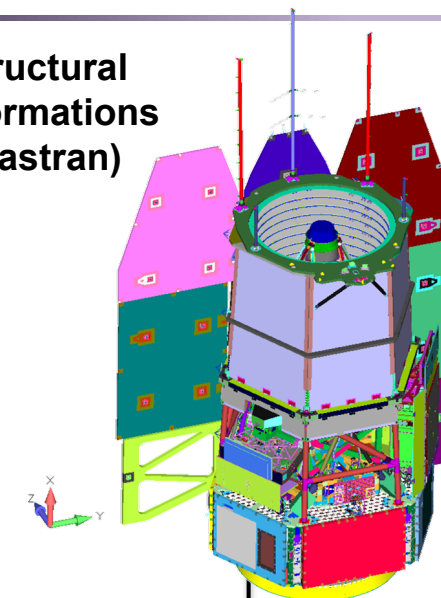

Nodal deformations

Opto-Mechanical Software

EllipTool

CGI Performance Predictions

- Wavefront Error
- Pupil Shear / Clocking
- Image Motion @ Cameras
- Chief Ray Angle of Incidence

Linear Optical Model

Optical Ray-Tracing (CodeV)

Optical Pre-Processing (SigFit)

- 6DOF motion of individual optics in local CSYS

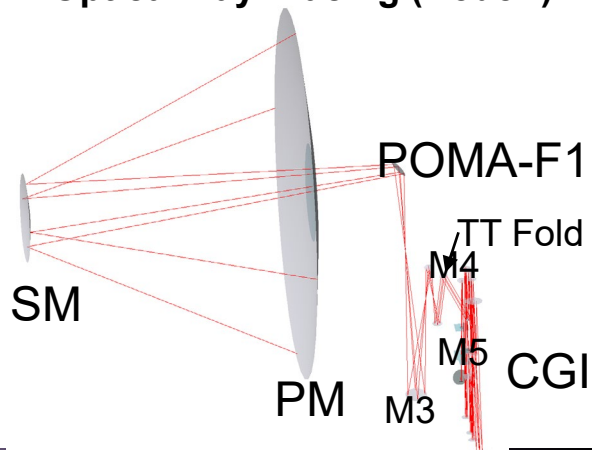



Roman Instrument Carrier Example (Optical Sensitivity to ΔT)



Create WFE Sensitivity to Temperature Variations

Sub-divide IC into individual beams and joints

FEMAP API



Compute WFE sensitivity to CTE variation in each beam/joint

Nastran SOL 200 sensitivity analysis



Convert CTE sensitivity to temperature sensitivity



Use these results along with data from gradient and bulk temperature change studies to generate thermal stability requirements

DESVAR ID	Property	Rank	Chunk			WFE Sensitivity [nm / deg K]
			ID	Type	CTE Value	
1361	A	1	91	Joint	8.534E-06	0.364
1377	A	2	99	Joint	8.560E-06	0.322
1363	A	3	92	Joint	8.538E-06	0.244
1375	A	4	98	Joint	8.558E-06	0.203
1383	A	5	102	Joint	8.541E-06	0.185
1365	A	6	93	Joint	8.541E-06	0.183
1379	A	7	100	Joint	8.559E-06	0.161
1393	A	8	107	Joint	8.568E-06	0.156
1034	A1	9	9	Beam	-3.049E-07	0.144
1090	A1	10	23	Beam	-3.048E-07	0.109
1373	A	11	97	Joint	8.558E-06	0.109

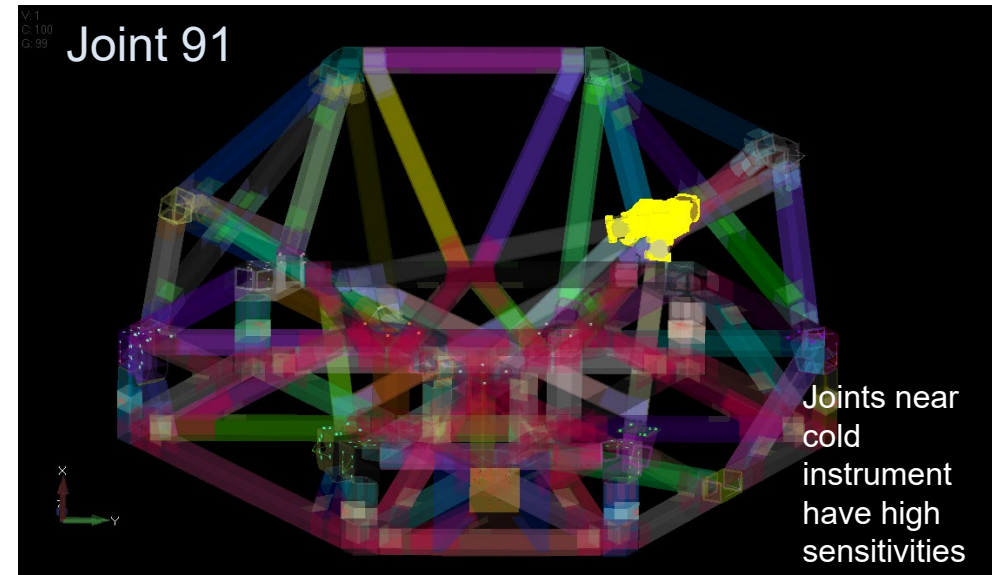



Roman STOP Mapping Process



STOP Mapping Pipecleaner Process



- **Before mapping production runs that will go through entire STOP process, verify that the mapped temperatures are reflective of the thermal results**
 - Roman calls this the Mapping Pipecleaner
- **Mapping Pipecleaner is an iterative process with the structural team to ensure high-quality temperature maps**
 - Often requires multiple group edits which require new FEM deliveries
- **Product of this process are Mapping Pipecleaner Slides which provide a side-by-side comparison of temperatures on thermal model vs temperatures on FEM**
- **Roman has developed tools to automate parts of this process**

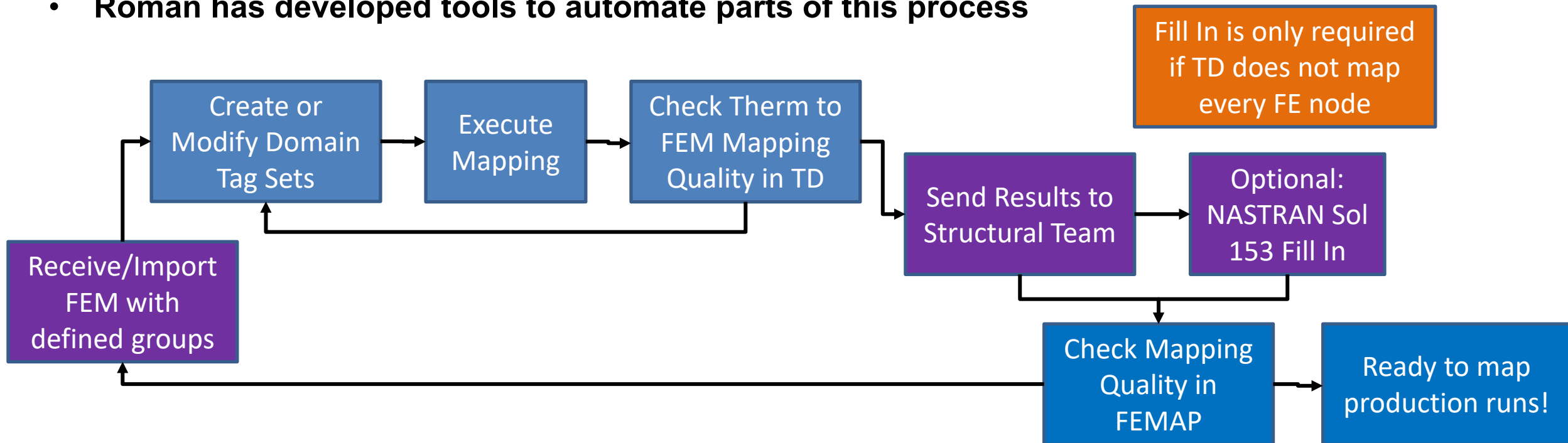



Importing a FE Model into Thermal Desktop for Mapping



- **Receive .neu with FEM with thermal groups from structural team**
 - Must be FEMAP version 10.2
- **Create Post Processing Data Mapper to import the .neu**
 - Thermal -> Export -> Post Processing Data Mapper
 - Type: FEMAP
 - After importing, Post Processing Data Mapper box appears
 - **Click Edit Group Associations to see the FEM thermal groups**
 - Not an easy way to copy the whole list of FEM groups to your clipboard
- **Define Domain Tag Sets in Thermal Desktop for each FEM thermal group**
 - Thermal -> Domain Tag Set Manager

Post Processing Data Mapper

Comment: Cycle 1 Rev 1 Phase B FEM w/ groups and pipecleaner

Input/Output
FEMAP Input File: PhB_Cy1p1_Thermal_Groups_181030.neu
Output Format: NASTRAN Single Output File
Output File: Cyc1_Rev1a_IC_WFI_slew_constQ.dat

Data Mapping
 Use all entities in the thermal model
 Use AutoCAD group:
 Associate groups Edit Group Associations...

Data To Map
 Map post processing dataset at current displayed time
 Map post processing dataset for all times in dataset
 Map for selected times Edit Selected Times...
Start Time [sec]: 0 End Time [sec]: 1
 Output element / gradient data for planar elements (TEMP1)

Gradient Mapping
 Use all entities in the thermal model
 Use AutoCAD group:
 Associate groups Edit Group Associations...
 Use structural thickness for gradient calculation

Preferences
Display Preferences...
 Create graphic markers for locations that fail to map
 Save Mapping Results on DWG

Mapping Control
 Use Advanced Mapping
 Track Multi Map Temp Diff [K]: 1
Mapping Tolerances...

Output, No Calcs Exit & Map Exit Cancel Help

Structural to Thermal Group Associations

Associate structural node groups with ACAD groups for temperature mapping

Structural Group Name	AutoCAD Group Name
SC-BAY1-PHASEB-IM-083118.BDF	BUS_MAP_MOD1
SASS_Panel_4_181003.bdf	ARRAY_PAN4_MAP
SASS_Panel_5_181003.bdf	ARRAY_PAN5_MAP
SASS_Panel_6_181003.bdf	ARRAY_PAN6_MAP
SC-BAY1-PHASEB-IM-083118.BDF	BUS_MAP_MOD1
SC-BAY2-PHASEB-IM-083118.BDF	BUS_MAP_MOD2
SC-BAY3-PHASEB-IM-083118.BDF	BUS_MAP_MOD3
SC-BAY4-PHASEB-IM-083118.BDF	BUS_MAP_MOD4
SC-BAY5-PHASEB-IM-083118.BDF	BUS_MAP_MOD5
SC-BAY6-PHASEB-IM-083118.BDF	BUS_MAP_MOD6
SC-BOTDECK-PHASEB-IM-083118.BDF	BUS_MAP_BOTTOM_DECK
SC-CC-PHASEB-083118_IM_181003.BDF	BUS_MAP_CENTER_CYL
SC-LONGERONS-PHASEB-IM-083118.BDF	BUS_MAP_LONGERON
SC-DBA-SUPPORTSTURTS-PHASEB-IM-083118.BDF	EPC
SC-PAFADAPTER-PHASEB-IM-083118.BDF	BUS_MAP_PAF_ADAPTER
SC-PROPDECK-PHASEB-IM-083118.BDF	BUS_MAP_PROP_DECK
SC-PROPDECKSTIFFENER-PHASEB-IM-083118.BDF	EPC
SC-PROPSYSTEM-PHASEB-IM-083118.BDF	BUS_MAP_PROP_SYSTEM

Use all thermal entities for structural groups that do not specify an AutoCAD group



Domain Tag Sets



- In Thermal Desktop, Domain Tag Sets are used to group thermal objects

- Post Processing Data Mapper references Domain Tag Sets
- Each TD object can be assigned to multiple Domain Tag Sets

- **Creating Domain Tag Sets**

- Thermal -> Domain Tag Set Manager -> Create
- Naming format: *subelement_MAP_yourgroupname*
 - Use standard prefixes when naming to keep list tidy
- Objects Type – for mapping, select Face Set, Solid Set, or Any Set
 - You cannot change the Objects Type after creating – get it right!
 - **Only faces and solids will map, be sure to include them**
- Define a Domain Tag Set for each FEM thermal group

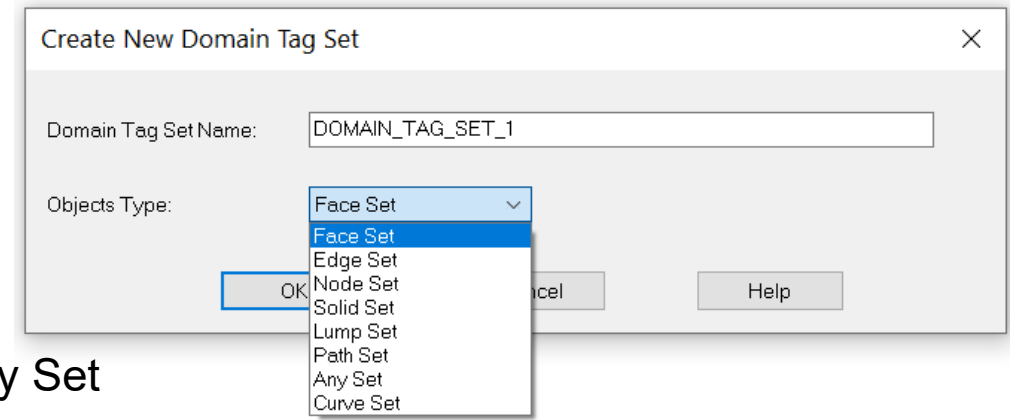

- **Tips & Tricks:** to reference a Domain Tag Set when creating contactors, press “d” when you’d usually select a to/from surface

- **Domain Tag Sets are lost when integrating geometry between models unless you import the entire model**
- **Roman has generated VB tool to import & export Domain Tag Sets between models**



Executing and Verifying Mapping

- **Verify Post Processing Data Mapper settings for mapping**
 - Edit Group Associations
 - Assign each FEM thermal group to a domain tag set
 - Mapping Control
 - Roman does not use Advanced Mapping
 - Set Mapping Tolerances
 - Casts incrementally wider net to attempt mapping
 - 0mm, 0.001mm, 0.002mm...1mm, 2mm...up to 110mm
- **When you're ready to map, press Exit & Map. When it finishes, it's time to begin inspecting!**
- **Tips for looking at the FEM**
 - The only way to look at the FEM group-by-group is by highlighting it in Edit Group Associations, right-click, then Display Only
 - The Thermal Desktop Post-Processing auto-scale scales to the ENTIRE mapped FEM. To look at a properly scaled FEM...
 - From Edit Group Associations, highlight group and Display Only
 - Toggle off visibility of FEM Mappers
 - Command: RCTOGGLEMESHDESPLOYERVIS
 - Look at thermal geometry in TD PP window (make temperatures scale to only thermal model)
 - Toggle visibility of FEM back on
 - Now the FEM can be viewed with correct temperature scale



Things to Look For



- **Group by group, capture the gradient on the FEM to make sure it looks like the gradient on the thermal model**
 - Make Pipecleaning Slides – one slide per group
 - Capture images of both the thermal model and FE model
 - Make sure to note the model & timestep used to generate the maps
- **Qualitatively inspect each group's mapping**
 - Evaluate the scale and look of the gradient
 - Incorrect mapping is bad and needs attention
 - Bleed over between elements
 - Hot vs cold side of thermal interfaces
 - Gradients across flexures / thermal isolators
 - Mysterious hot and cold spots
 - Totally incorrect gradients
- **Incomplete mapping is okay**
 - Structures uses NASTRAN Sol 153 to fill-in missing temperatures
 - Consider how TD's mapper expands, not interpolates or extrapolates, your gradient onto the higher-resolution FE Model
 - Consider a honeycomb panel with separate thermal surfaces for the two facesheets (and only a contactor representing the core) mapping to a FE model that has many nodes representing the panel's core
 - TD Mapper would map top half of FE core to top thermal facesheet and bottom half of FE core to bottom facesheet with a discontinuous gradient between them
 - Since core isn't represented with surfaces in thermal model, more reliable to simply map only the two facesheets then let fill in interpolate
- **If you have issues**
 - Ask structural team to break up thermal groups with more resolution
 - Reduces bleed-over of elements that are close to one another (like brackets, flexures, gimbals)
 - Moving components in thermal model will require less time than moving FEM
 - Not possible to move individual groups in FEM

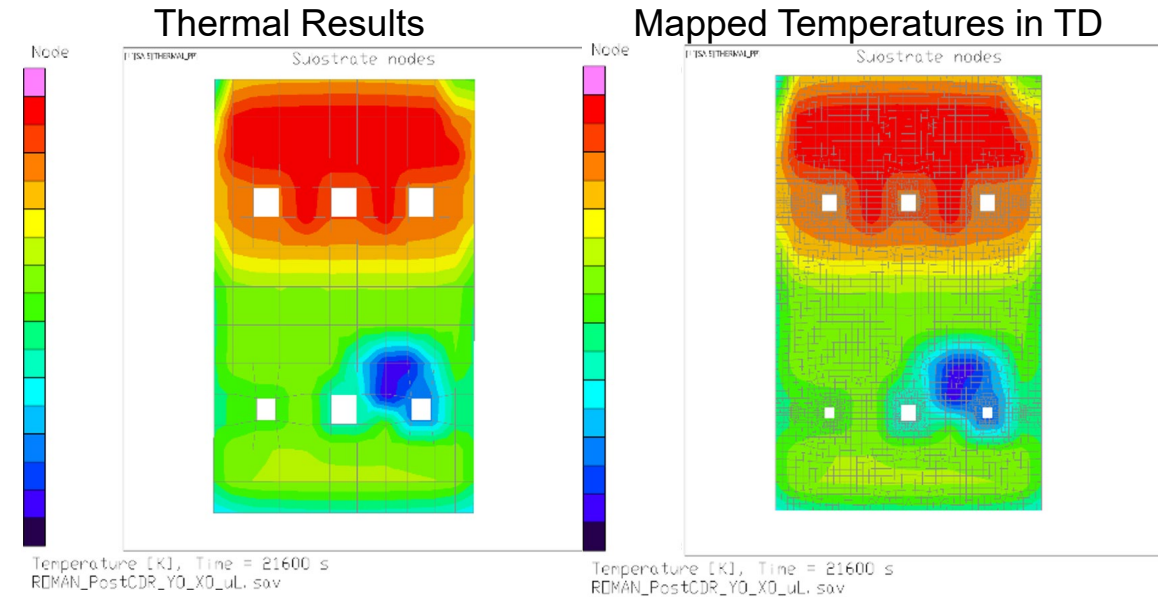



Example Pipecleaning Slide

Use maximum Number of Shades (15) and consider significant digits when viewing in TD

FEMAPs Color Bar can be modified to match Thermal Desktop's – makes side-by-side comparisons easy

Thermal Model

Mapped Temperatures in FEMAP

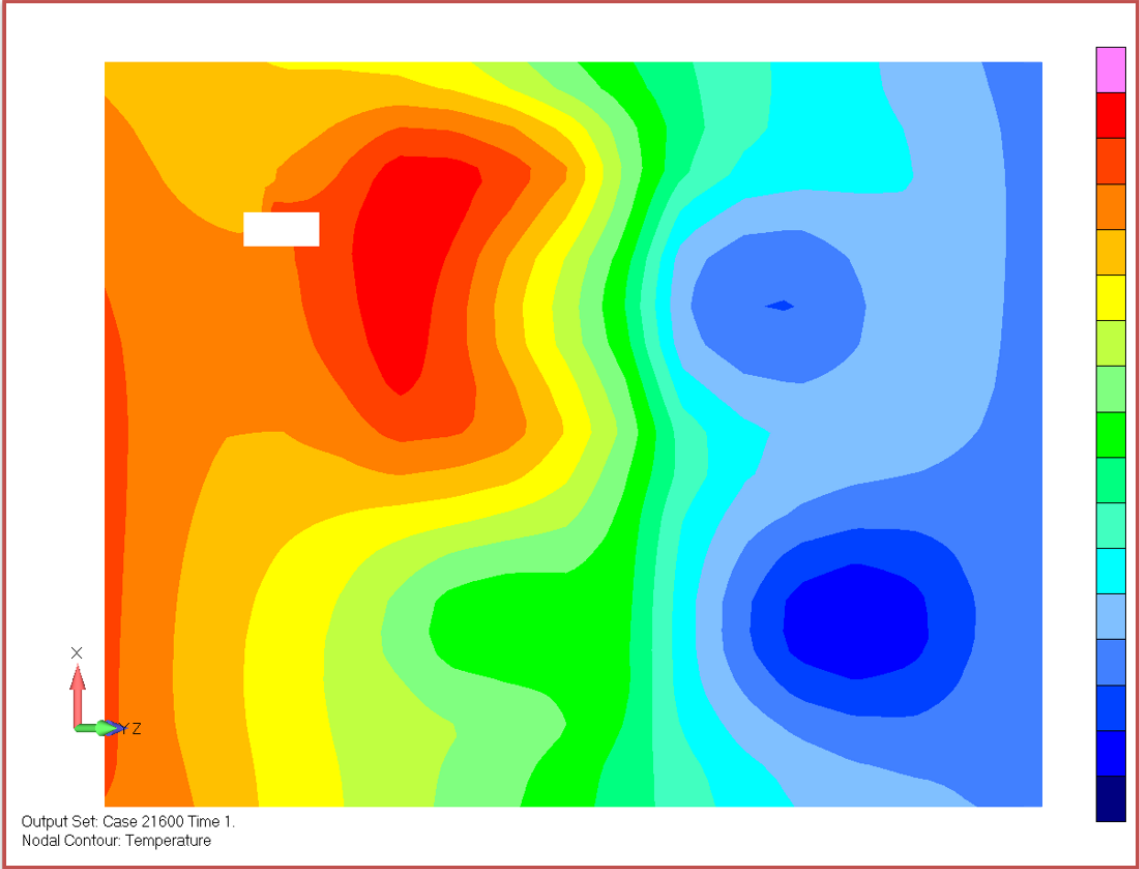
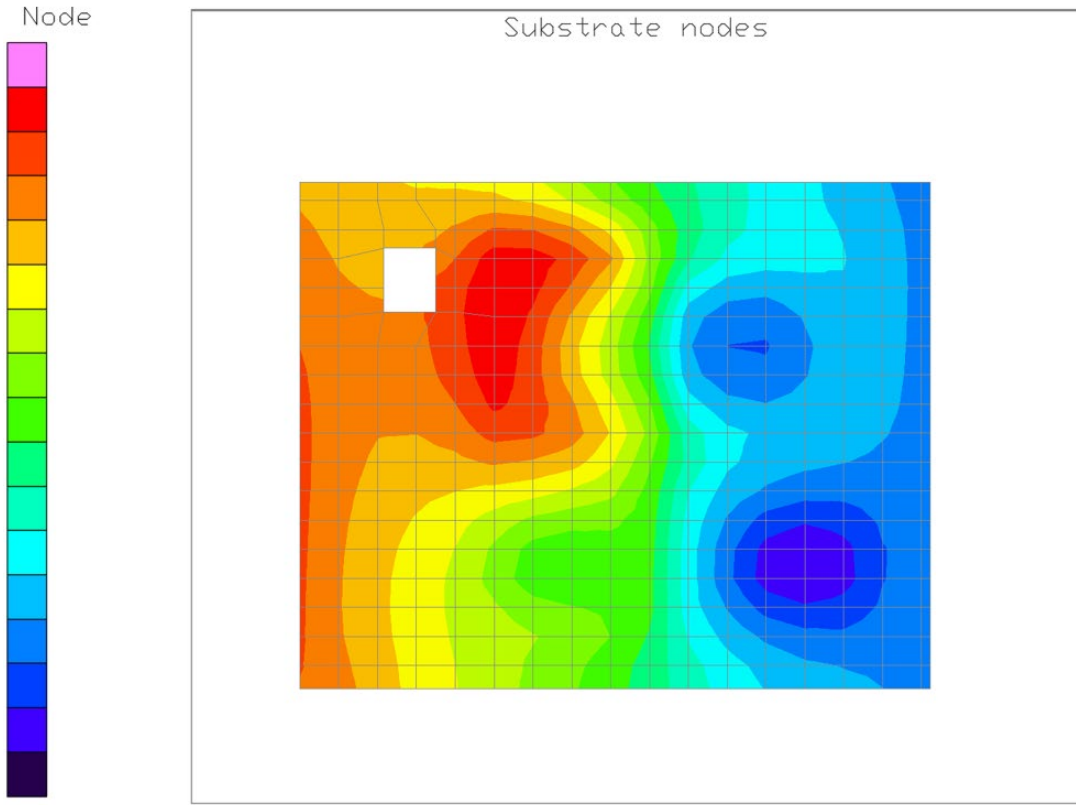

Temperature [K], Time = 21600 s
ROMAN_PostCDR_Y-36_X15_Hot_pipecleaner.sav

Output Set: Case 21600 Time 1.
Nodal Contour: Temperature

Note the view, filename, and timestep



Verifying Mapping Quality

- Sometimes, the mapper is working and producing high quality maps but autoscaled temperatures wash out the gradients
- Be diligent and break things into smaller groups so you can notice potential errors

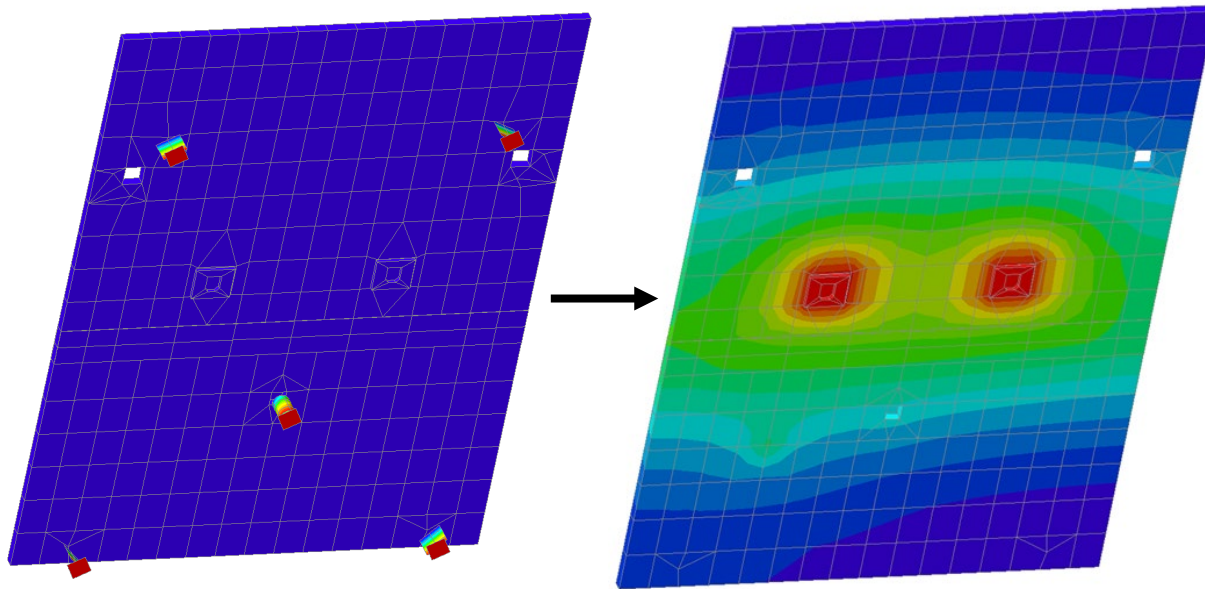

Autoscaling washes out gradients on stacked optical elements

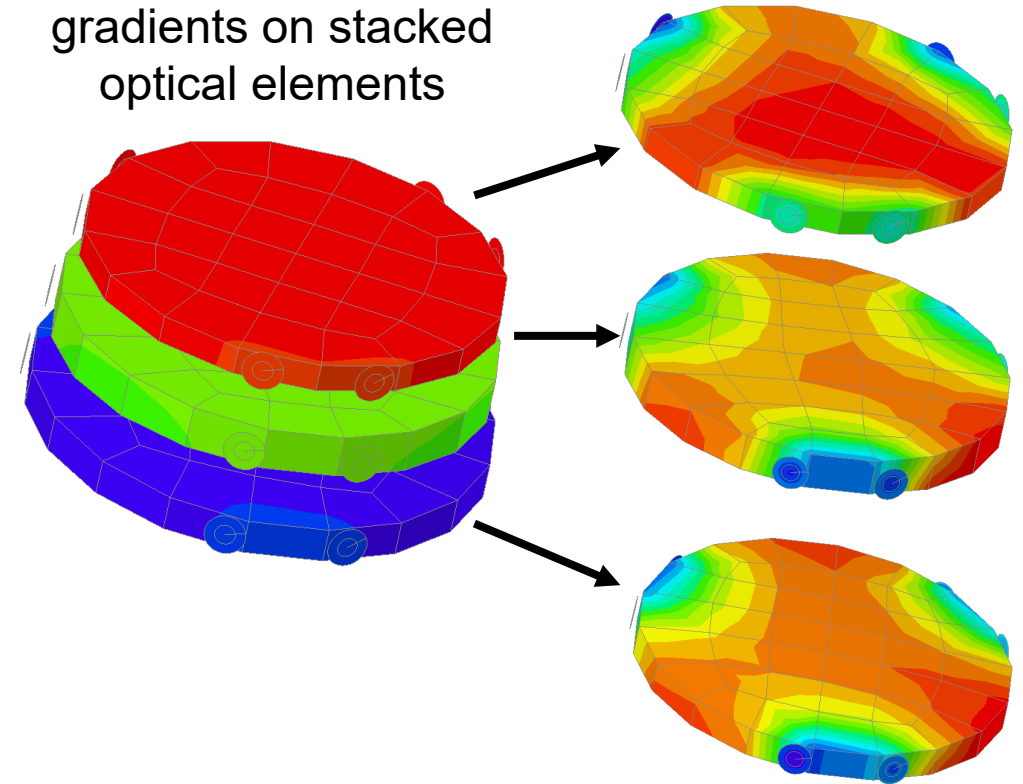

Autoscaled contours of cryogenic radiator with vs without mounts



Mapping Issues: Thermal Isolators



- **NASTRAN Sol. 153 can be leveraged to solve some mapping issues**
 - Honeycomb core example
- **At thermally isolating interfaces, mapping can be challenging unless geometry is exceptionally well aligned**
- **Mapping the two sides of the interfaces and letting Sol 153 interpolate between them is often more accurate than trying to map every node**

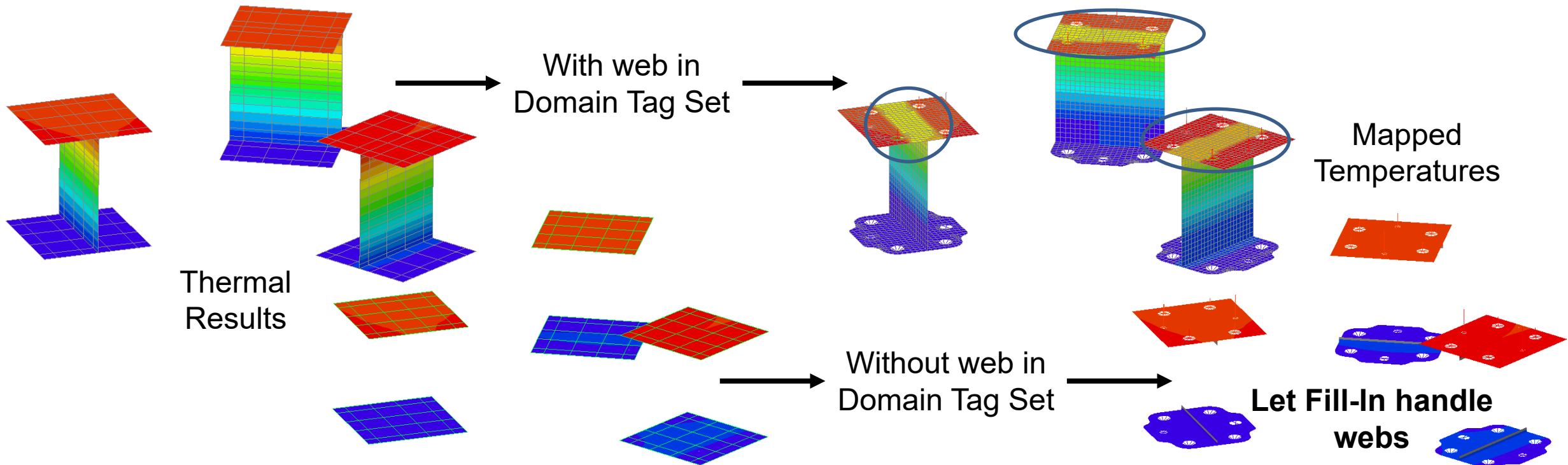



Mapping Issues: MLI

- **MLI-only surfaces should not be included in mapping Domain Tag Sets**
 - Maps unrealistic gradient onto structural model
 - Generally, stands out as a discontinuity or extreme hot/cold spot that washes out autoscaling

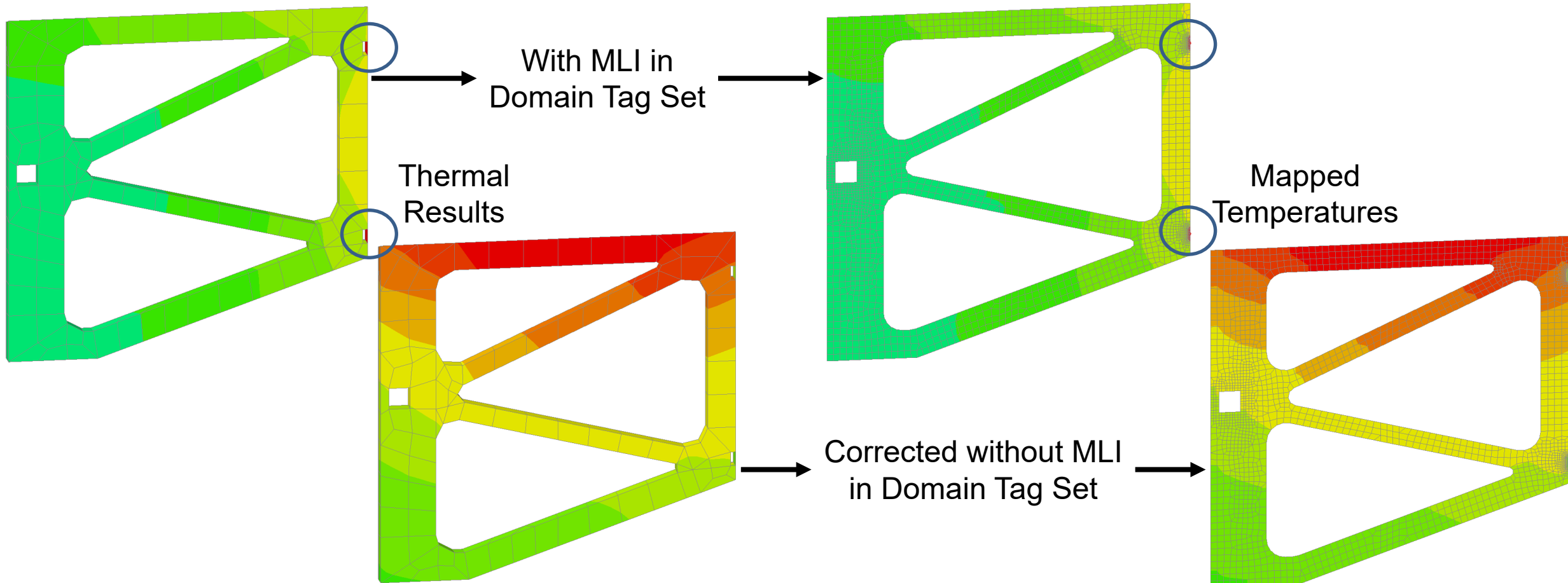



Mapping Issues: Overlapping FE Groups



Original Thermal Results

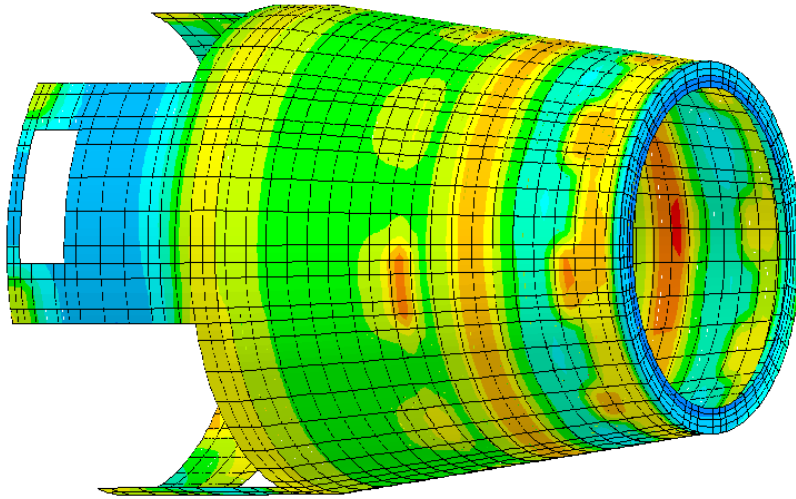

Temperature Map After Fill In

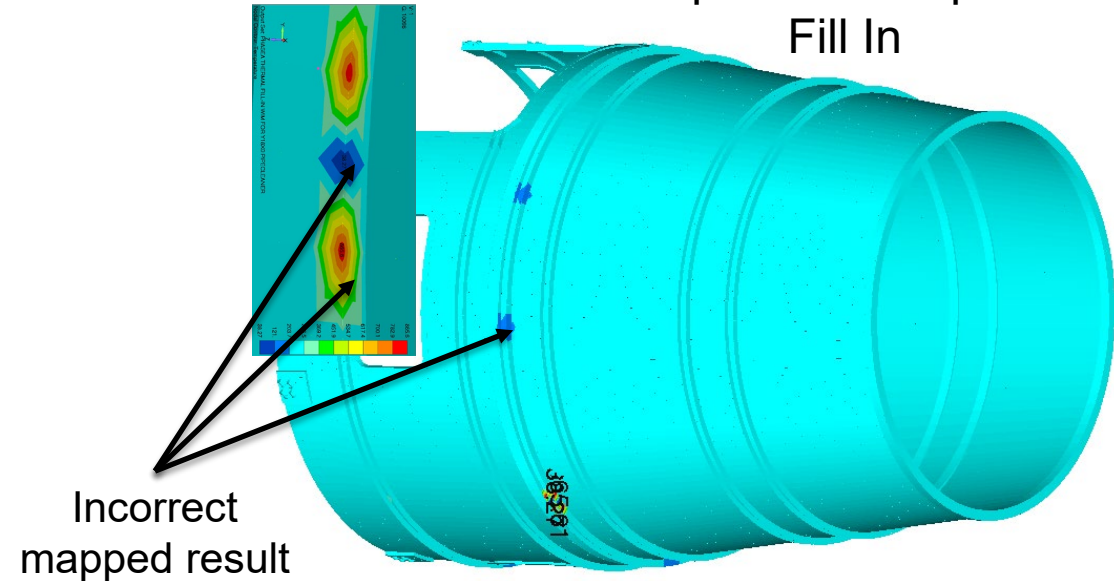

- **If an FE node is assigned to multiple FE groups, mapping errors are likely**
 - Each FE node will only map once
- **These errors are an example of bleedover across interfaces**
 - Here, temperatures from hot Solar Array Support Structure are mapped onto colder Outer Barrel Assembly
- **Only solution is to correct FE nodal group assignments in FEMAP**

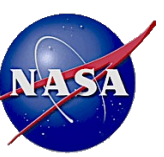

Mapping Issues: Alignment

- **Sometimes, geometry in FE model and geometry in Thermal model simply don't align**
- **If you are unable to resolve this by communicating with teammates, attaching misaligned thermal model geometry to articulators is a solution**
 - With Post Processing Data Mapper, you cannot move individual parts of FEM without moving the entire mapper
 - Control articulators with a symbol to move it between Mapping and Analysis positions
 - If you're working with thermal models that were delivered to you, safe to assume they are intended to run in the as-delivered position
 - Be sure you aren't unmerging nodes – resetting the articulator to the Analysis configuration should make it identical to the original model
- **SPECIAL CASE: your model may already include articulating geometry – make sure you know the configuration that matches the FEM's configuration**
 - Roman examples include High Gain Antenna and Element Wheel
 - It is perfectly acceptable to run your analysis in one articulated configuration and map in another
 - Utilizing symbols to quickly & reliably return geometry to its Mapping Position is helpful



Mapping Issues: Alignment

Thermal Results

Mapped Temps Before Alignment

Offset optics require translation & rotation to align

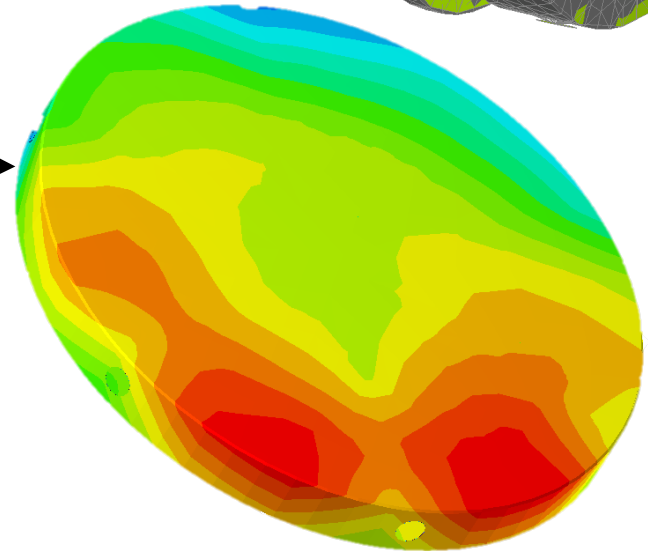
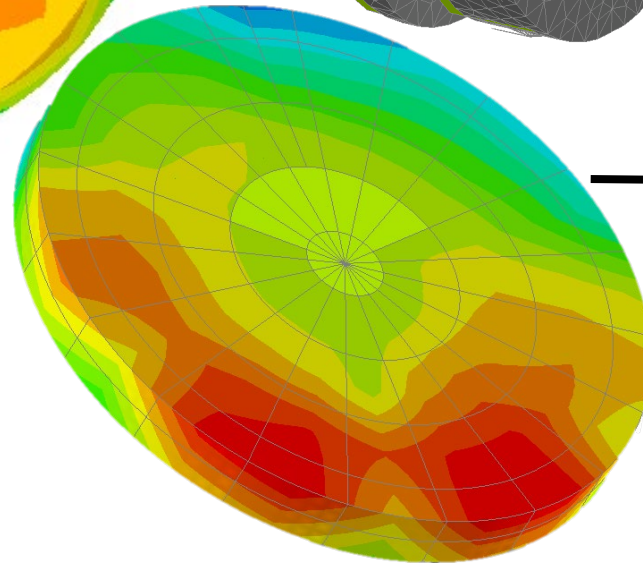
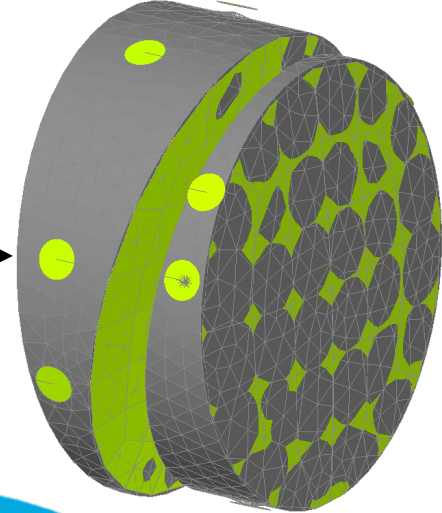
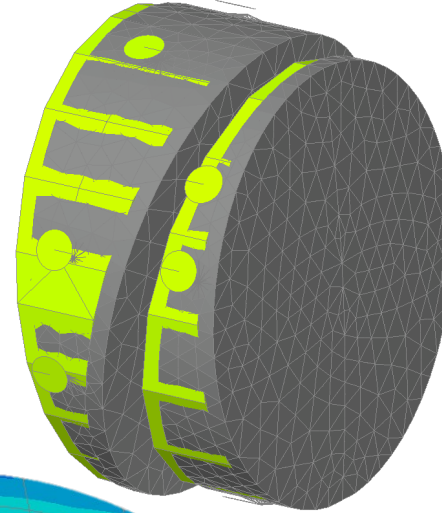
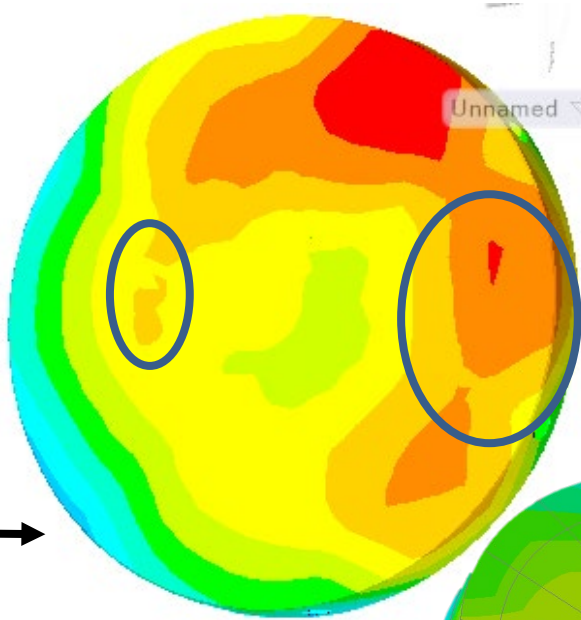
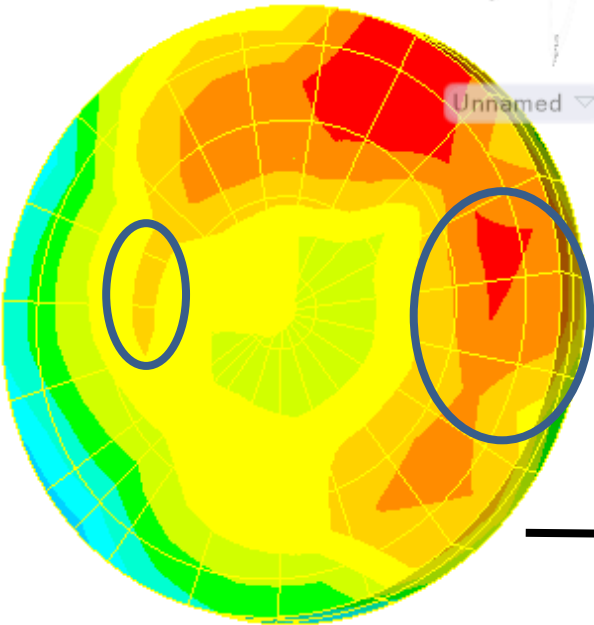

Tiny offsets between Thermal and FE models lead to different gradients when mapping

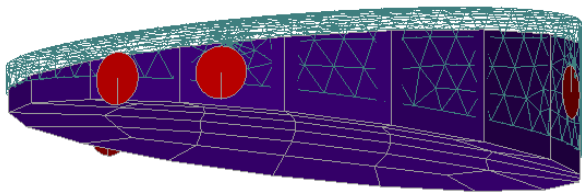

Thermal Results

Mapped Temps After Alignment



Master Group Spreadsheet



- **Master Group Spreadsheet is a tool that enables automated image-capturing in both Thermal Desktop (working) and FEMAP**
 - Required input: camera orientation & min/max temperature
 - Views tab allows user to create a set of predefined camera orientations (Camera X Y Z, Target X Y X, Roll Angle) or user can fill out custom orientations for each group
 - Type NVIEW to save current model view
 - Type VIEW command to see camera info in AutoCAD
 - Min and Max temperatures should match TD's autoscale for each associated Domain Tag Set

Views tab for predefined camera orientations

View Name	Camera (Eye)			Target			Roll Angle
	X	Y	Z	X	Y	Z	
CGI DM 1	3.29941	-2.03877	-0.32074	3.02859	-1.34555	-1.43243	107.985
CGI DM 2	3.32011	-1.08461	-0.5974	3.198	-0.7298	-0.59224	89.408
CGI EHTS	4.67818	-0.37036	1.83602	2.87009	-1.2605	-0.37991	213.642
CGI FCM	3.06855	-1.10682	-0.98633	2.99545	-0.75721	-0.98633	90
CGI FSM	3.42143	-0.75075	0.25887	3.28212	-0.82582	-0.09955	210.498
CGI LOBE	4.2324	-0.15919	-0.76774	3.94207	-0.47116	-0.76794	270
CGI OAP 2	3.26038	-0.55683	-0.74559	3.04796	-1.04448	-0.74559	270
CGI OAP 3	3.4684	-1.57748	-0.04465	3.27562	-1.57748	-0.54564	180
CGI OAP 4	3.70956	-2.11026	-0.29903	3.11052	-0.7351	-0.29903	90
CGI PAM 1	3.38454	-0.80636	-0.756	3.10054	-1.13324	-0.756	270
CGI PAM 2	3.33093	-0.82401	-0.58228	3.07873	-1.11429	-0.58228	270
CGI PAM 3	3.35042	-1.18231	-0.60148	3.1034	-1.18231	-0.35446	0
CGI PAM 4	3.37749	-1.6281	-0.71504	3.1027	-1.3986	-0.33121	48.796
CGI PAM 5	3.20096	-1.6795	-0.55099	3.02559	-1.53303	-0.30603	48.796
CGI PAM 6	3.15474	-1.40431	-0.68611	3.0033	-1.27783	-0.47458	48.796

FE Name C3	View Name	Camera (Eye)			Target			Roll Angle	Legend	
		X	Y	Z	X	Y	Z		Min	Max
1000	IOA	#N/A	#N/A	#N/A	#N/A	#N/A	#N/A	#N/A		
1002	IOA_AMS	5.02474	4.48335	-0.06826	3.52914	0.50886	-0.0205	270	265.453	266.147
1003	IOA_AMS_Lugs	5.02474	4.48335	-0.06826	3.52914	0.50886	-0.0205	270	265.453	266.147
1004	IOA_AOM_Bench	5.02474	4.48335	-0.06826	3.52914	0.50886	-0.0205	270	209.628	218.76
1005	IOA_AOS_Struts_Compensators	5.02474	4.48335	-0.06826	3.52914	0.50886	-0.0205	270	232.432	243.02
1006	IOA_AOS_Struts_Flexures_and_AMS_Fi	5.02474	4.48335	-0.06826	3.52914	0.50886	-0.0205	270	217.767	266.752
1007	IOA_AOS_Struts_Tubes	5.02474	4.48335	-0.06826	3.52914	0.50886	-0.0205	270	234.512	239.058
1008	IOA_F1_Actuator_and_Mount	3.41061	-0.3124	-1.70528	3.37586	-0.24733	-0.58541	107.155	217.512	217.729
1009	IOA_F1_Mirror_and_Mounts	3.41061	-0.3124	-1.70528	3.37586	-0.24733	-0.58541	107.155	217.323	217.641
1010	IOA_F1_Rxn_Structure_and_Compensa	3.41061	-0.3124	-1.70528	3.37586	-0.24733	-0.58541	107.155	217.535	217.565
1011	IOA_F2_Mirror_and_Mounts	4.0368	0.62107	0.43986	3.47502	0.80174	-0.34134	138.742	217.27	213.361



- **Domain Tag Set Importer**
 - Domain Tag Sets cannot be exchanged between models with TD's native functions
 - If objects have identical identifiers in two models, Importer tool updates Domain Tag Sets in Model A to match Domain Tag Sets in model B
 - Uses OpenTD API
- **Domain Tag Set Min Max Extractor (in beta)**
 - Unless nodes are included in Domain Tag Sets, extracting min / max temperatures for many groups can be a challenge
 - Generates list of min / max temperatures at a given timestep for selected Domain Tag Sets
 - Easy to cut & paste into Master Groups Spreadsheet
 - Uses OpenTD API
- **Image Generator (in beta)**
 - Extracting images to generate Pipecleaning Slides can be time consuming
 - Requires Named Views in AutoCAD
 - User creates list of groups & views with Master Group Spreadsheet's FE_GROUP_NAME | VIEW_NAME format
 - For now, this uses AutoIt to interface with Thermal Desktop but working to implement directly in OpenTD API



Best Thermal Analysis Practices for IM



Roman's Single Thermal Model Approach

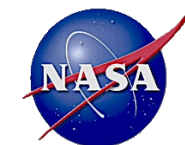

- **Roman generally uses the same model for Discipline Analysis as we use for Integrated Modeling**

- IM Thermal Model is a “frozen” version of the Discipline Analysis model
 - IM model is “frozen” before Mapping Pipecleaner checks
- Some components have even higher resolution IM thermal models for sensitive optics

- **Some projects might keep a lower-resolution STOP thermal model to save runtime**

- Roman has experimented with solution methods to save runtime

Benefits and Challenges for a Single Thermal Model Approach

Benefits	Challenges
<ul style="list-style-type: none">• Model traceability• FE models are generally even higher resolution than detailed thermal models• Accurate high-resolution temperature maps are essential to modeling ultra-sensitive optical systems	<ul style="list-style-type: none">• IM thermal model requires frequent design freezes• Long model runtime



Solution Method: Accounting for Modeling Uncertainty



- **ROMAN's IM team does not apply a numerical Modeling Uncertainty Factor to thermal results**
 - Applying directly to temperatures would be difficult to implement
 - Roman does apply a Modeling Uncertainty Factor to structural deformations
- **For IM analysis, the Discipline Analysis notions of Hot or Cold case don't really apply**
 - For example, say there is a room temperature instrument near a cryogenic temperature instrument. Leaky blankets are a Cold case for room temp instrument but Hot case for cryo temp instrument
- **ROMAN is primarily concerned with stability, so we bias model to encourage energy exchange**
 - More conductive interfaces (whether it is blankets or interfaces)
 - Highest Solar Flux, EOL optical properties
- **As the project has matured, IM's goal has become creating a worst *realistic* case**
 - Solar Array percent power draw varies as a function of attitude
- **Large Solution Timestep DTIMEI biases heater controller performance to be Worst Case**
 - Bigger timesteps = slower sampling rate
 - Sampling rate in model is much slower than sampling rate in reality



Solution Method: Initializing Cases



- **Utilizing a consistent solution method that achieves repeatable results is critical when developing & executing thermal cases for IM**
 - STOP performance is very sensitive to temperature changes
 - Temperature settling takes a long time, especially heavy optics far from active heater control
- **Roman cases use SINDA's Steady State Solution followed by a lengthy Transient Solution to achieve "quasi steady state"**
 - Thermostatic heaters are still cycling, so we don't call it a "true" steady state
 - When running Steady State, ensure you allow enough loops for a solution to be found
 - Inconsistent starting points lead to inconsistent results (or longer wait times)
 - When running Transient, STOP results can help you determine an appropriate "wait time"

WFE Stability During Settling

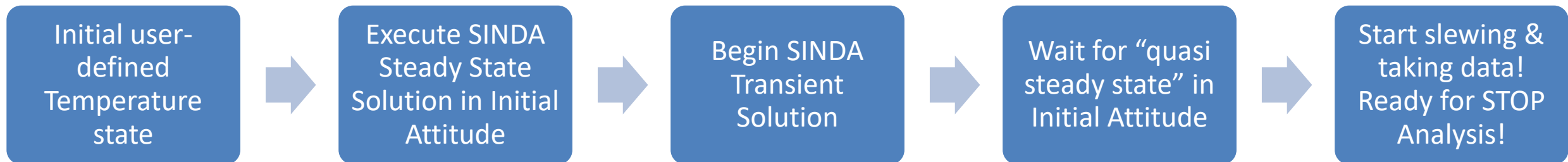
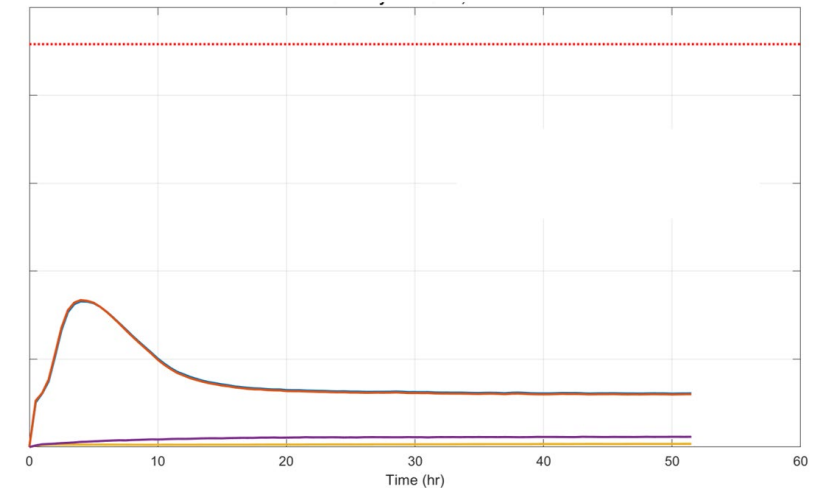



Solution Method: Case Design



- **Roman uses Static Wave Front Error results to design a Worst Case Slew**
 - In various attitudes within Roman’s Field of Regard (FOR), use STOP to analyze Static WFE in “quasi steady state” via thermal cases with an unchanging environment
 - Two attitudes with the biggest difference in Static WFE are assumed to compose our Worst Case Slew
 - Sampling other slews with high delta Static WFE is also useful
- **Worst Case Slew assume single instantaneous slew**
 - Wait 48 hours in Attitude 1, slew to Attitude 2, wait 48 additional hours
 - Instantaneous slew drives worst-case performance for 180-second & 2-hour WFE stability requirements
- **Other analysis cases are built to simulate actual operational scenarios**

Manhattan Plots
Difference in Static WFE Between Attitudes

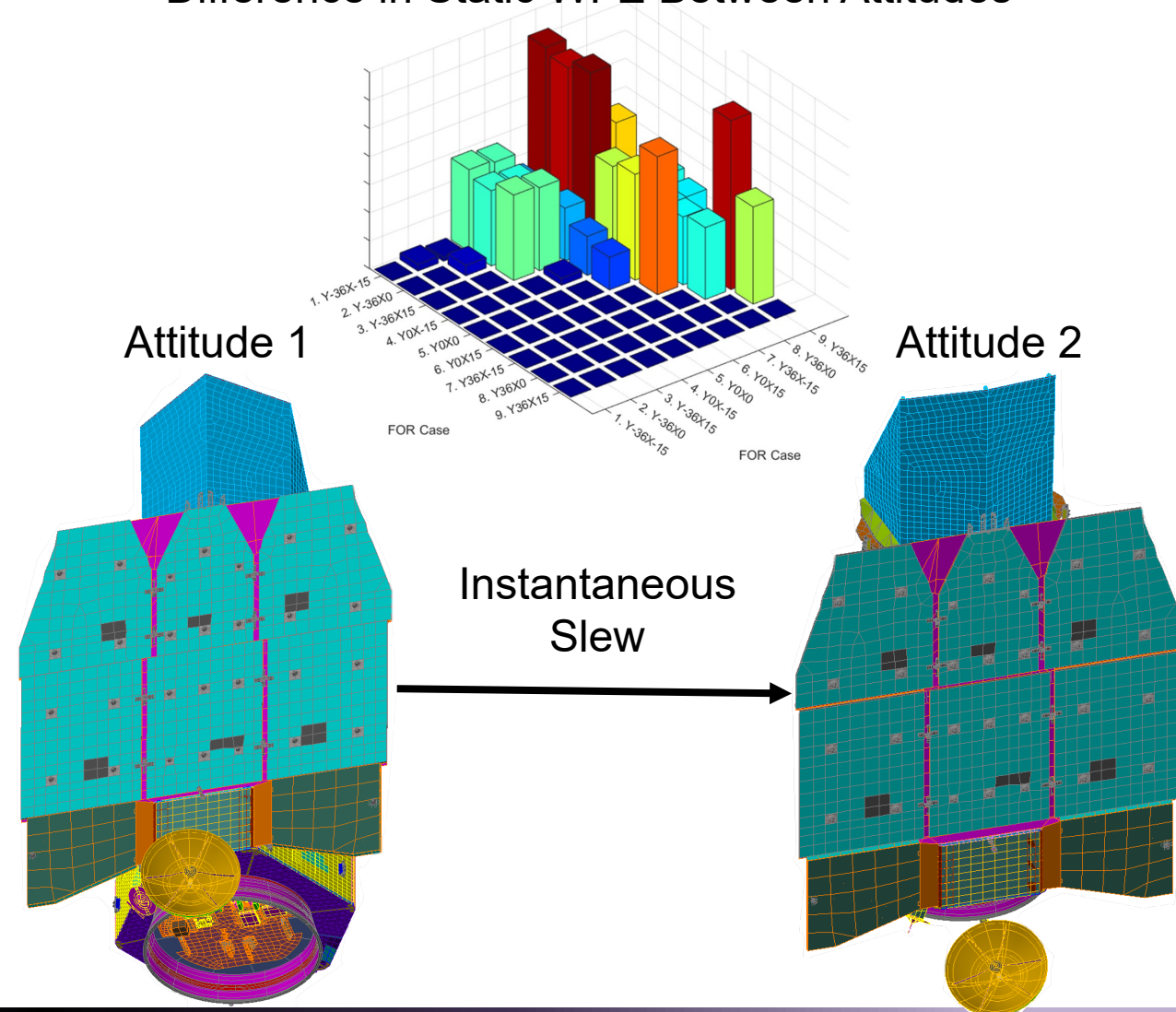



Solution Method: DTIMEI



- **Solution timestep (DTIMEI) sets the interval at which the model will solve**
 - Heater controller receives sensed temperatures
 - Controller calculates heat rates (J/s) for t_0
 - That heat rate is applied for DTIMEI (s)
 - After DTIMEI, controller updates sensed temperatures & repeats
- **Roman leverages a large solution timestep DTIMEI to bias heater controllers and to minimize model runtime**
 - Smaller DTIMEI increases runtime significantly; DTIMEI is inverse of runtime
 - Bigger DTIMEI results in unstable behavior because heat rates are applied for a long time before updating the heater controller
- **NOTE: be sure you are sampling frequently enough to capture instabilities!**
 - Roman records heater performance at all timesteps but STOP requires full temperature state

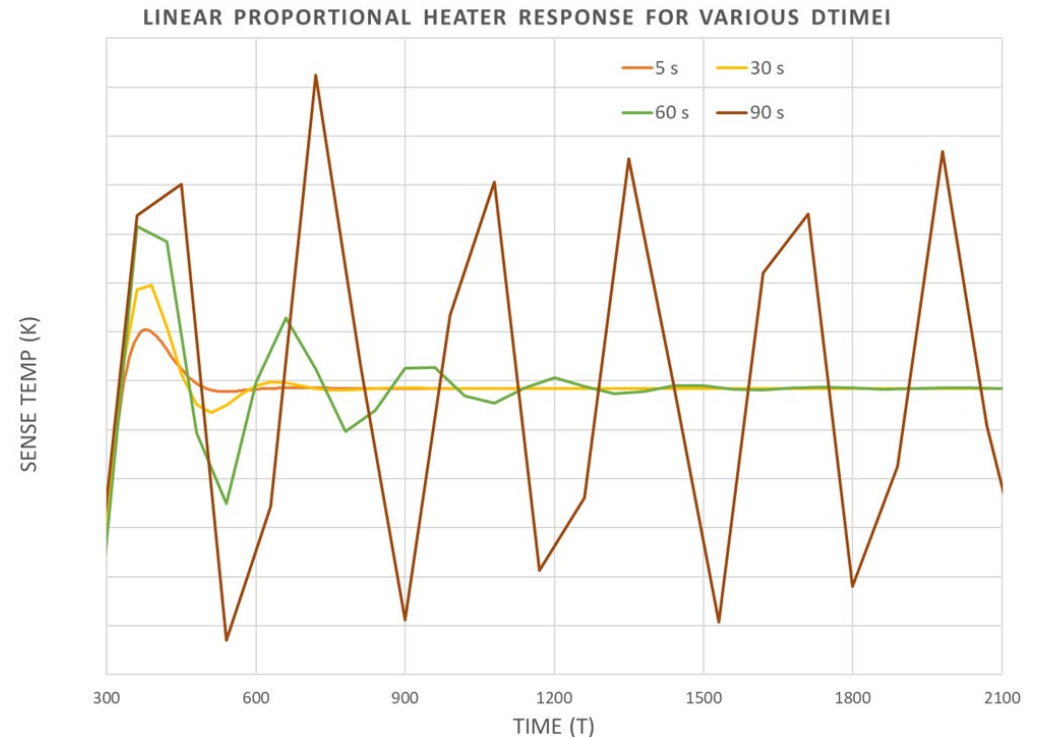

- As solution timestep increases, heater loses stability
 - Too much or too little power is applied for too long
- Bigger timesteps are more conservative analytically
 - Takes longer for heaters to find stability
 - Flight hardware will respond much more quickly than
- Roman IM team uses 60 second solution timestep to maintain conservative approach and save runtime



Solution Method: Heater Controllers



- The type and implementation of heater controllers should be considered along with DTIMEI when configuring a conservative IM case
- Understanding how heater control algorithms are executed is key to comparing modeled results vs what we can expect out of our design
 - Early in Roman’s design cycle, IM team biased heater controllers to be *less precise* than the actual design
 - PI controllers were modeled as linear proportional
 - Linear proportional controllers are more conservative since they don’t lock onto exact temperature
 - As Roman’s heater controller designs have matured, as have the models
 - Detailed Phase C controller models include sensor noise & heater clamping

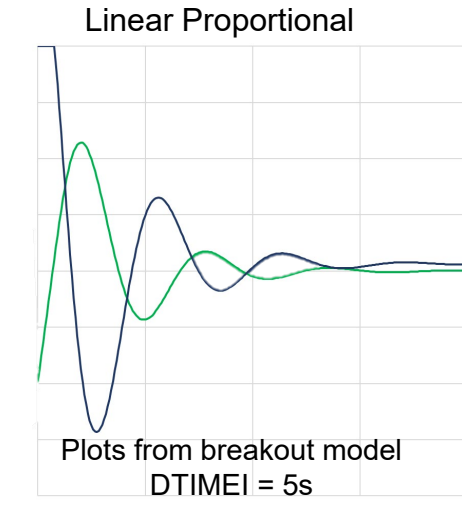
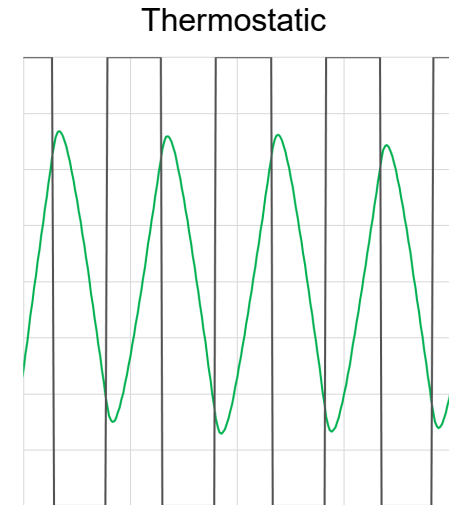

Plots from breakout model
DTIMEI = 5s
Only difference is control method
Plots share the same scale

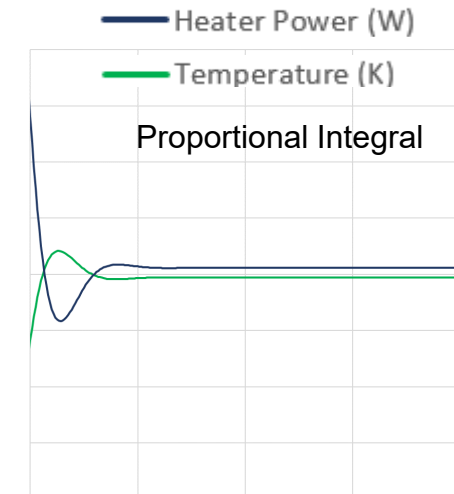
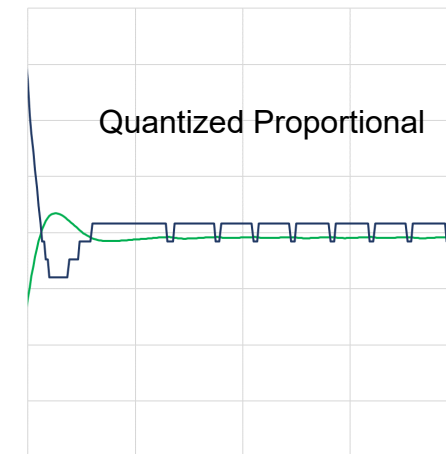

Controller Type	Applied Power	Summary of Method	Pros vs Cons
Thermostatic	Full on/off	Cycles between on/off set points	Cheap & easy to model Big deadbands unstable, can overshoot SPs
Linear Proportional	Set by FSW	Uses setpoints to create linear scale where Q=0 for off temp, Q=max for on temp	Stable, doesn't require constant tuning Does not lock onto exact temp, finds SS
Quantized Proportional	Modeling Trick	Linear prop w/ power applied in discrete intervals	Technique for modeling PWM w/o adding runtime - not in actual design
Proportional Integral (PI)	Set by FSW	Uses PI gain terms to control	Locks on for exact temperature control Needs to accumulate error. Requires tuning
Pulse Width Modulated (PWM)	Full on/off	FSW determines # of short (0.5 sec) full on/off pulses to hold temperature	Better stability than t-stat, cheaper than prop Runtime and model complexity



Identifying Poor Optical Performance From Thermal Results



- **When temperature stability requirements have not been derived, design teams likely don't have temperature stability in mind**
 - Discipline analysis primarily concerned with meeting hot / cold requirements
- **Still, large temperature swings over a short period of time can break stability requirements**
 - Know the time duration of your optical stability requirements and use it as a sliding window to check for dangerous temperature swings

Thermostatic Heater Temperature Stability

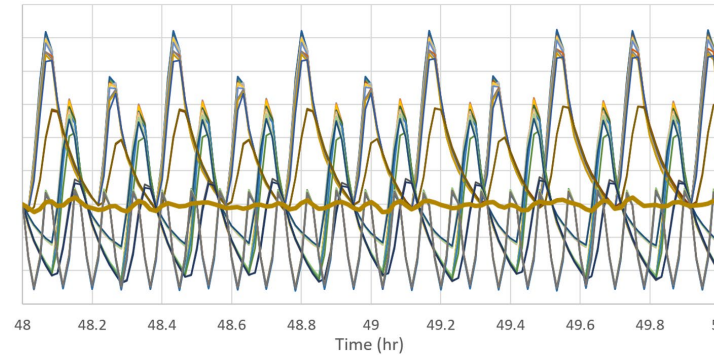

Thermostatic Heater STOP Results

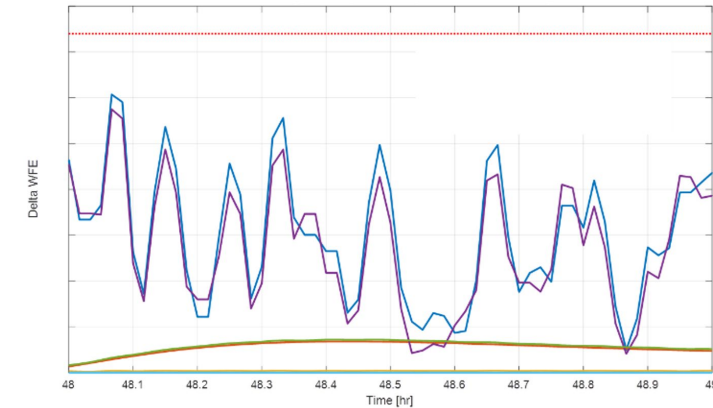

Proportional Heater Temperature Stability

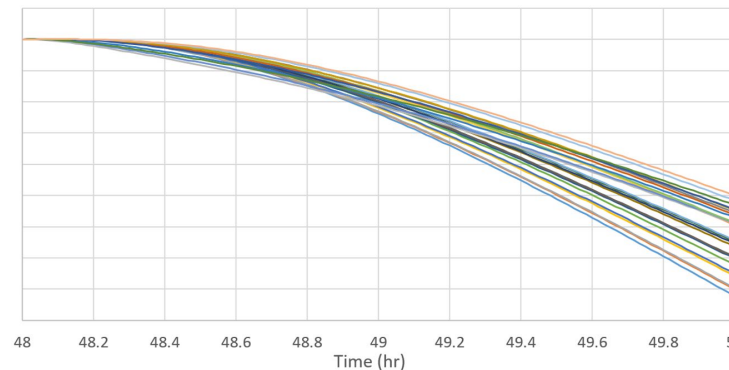

Proportional Heater STOP Results

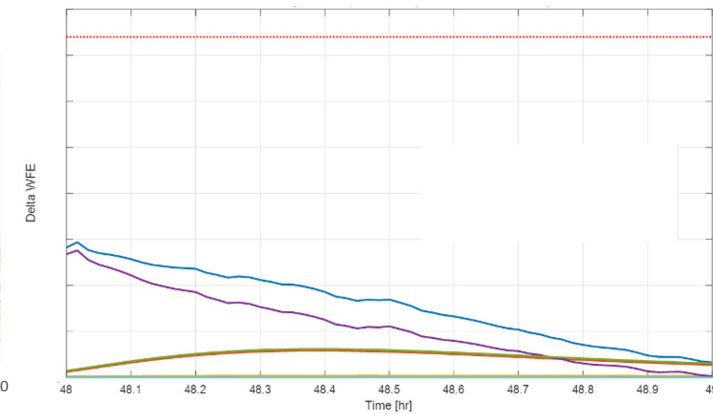

NOTE: Delta Temperature scaled 1/20th thermostatic plot



Roman Model Validation



Model Verification and Validation Introduction



- **Definition from NASA Modeling and Simulation Standard (NASA-STD-7009A w/Change 1)**
 - Model Verification: The process of determining the extent to which an M&S is compliant with its requirements and specifications as detailed in its conceptual models, mathematical models, or other constructs.
 - Math Models Guideline
 - Crosscheck and independent analysis
 - Model Audit Team
 - Model Validation: The process of determining the degree to which a model or a simulation is an accurate representation of the real world from the perspective of the intended uses of the Modeling & Simulation (NASA-STD-7009A w/Change 1)
 - Model Validation Plan
- **General approach is to correlate models at lower levels and use higher-level tests for model validation and interface model correlation**
- **Material presented today highlights thermal model validation plan, as well as thermoelastic model validation and optical verification that requires thermal support**



General Thermal Model Validation Approach



- **Perform early risk reduction thermal testing to measure key conductances (heat strap interfaces, conductive path to radiator) and material properties over expected temperature range**
- **Perform sensitivity analysis to inform optical sensitivity to thermal parameters**
 - Determine component uncertainty and evaluate prediction against requirement margin
 - Determine additional testing (if any) required to validate transient model
- **Thermal vacuum and balance tests**
 - Steady State Thermal Balance testing performed for thermal model correlation and verification of the thermal design
 - Validated element level models delivered and integrated into Observatory model
 - Spacecraft bus plus integrated payload thermal balance test validates element interfaces
 - Transient thermal model correlation uses data from hot-to-cold transitions or dedicated setpoint step changes
 - Levels, ramp rates and durations used will bound worst-case flight expectations
 - Transient tests are being considered for model correlation and to directly validate the adequacy of the thermal design for stability
 - Demonstrate heater control capabilities to meet required temperature stability and adjustment (i.e. tuning) if necessary



Thermal Model Validation Flow

- 1 All payload elements include a thermal balance test at the element level for thermal model correlation
- 2 Spacecraft (SC) Bus thermal balance test is performed at the Spacecraft + Integrated Payload Assembly (SCIPA) level
- 3 SC Optical Barrel Assembly, Solar Array and Sunshield, and Deployed Aperture Cover (OSD) has an assembly-level thermal balance test
- 4 SCIPA TVAC is the primary system-level thermal test to understand end-to-end system performance

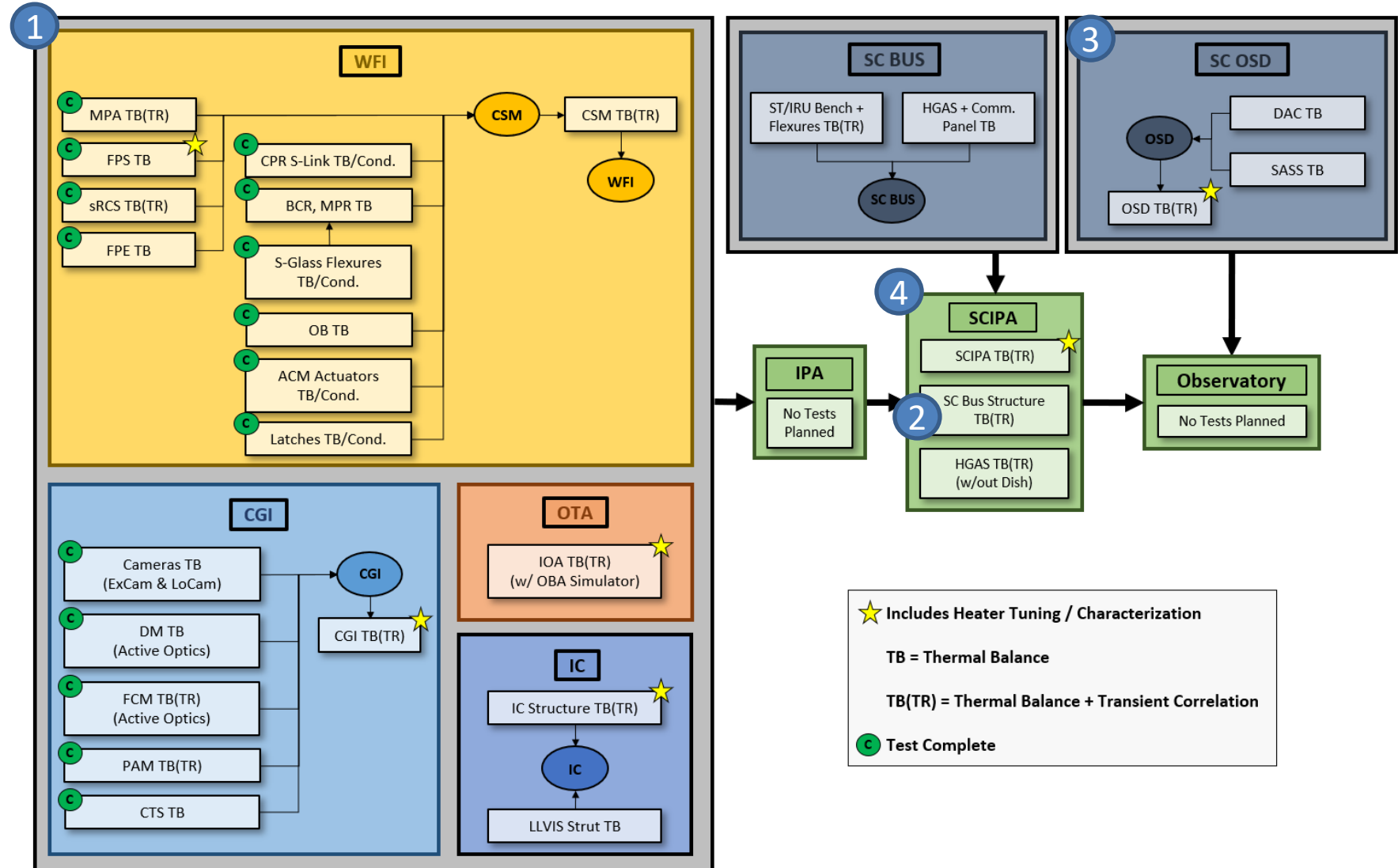



Example 1: OBA-SASS-DAC Thermal Vacuum Test



Flight Optical Barrel Assembly (OBA) + Solar Array and Sun Shield (SASS) + Deployed Aperture Cover (DAC) = OSD
OSD cycling and balance test is performed in TVAC chamber. This test is critical in understanding the behavior of the OBA thermal control system, which affects telescope temperature environment.

Test Objectives:

- 3 Thermal balance tests to correlate OBA thermal model
- Transient Tests for model correlation
- OSD heater verification
 - Determine preliminary controller gains for the FSW controlled heaters
- Demonstrate temperature stability at telescope simulator locations meets interface requirements
- 4 protoflight thermal cycles to verify thermal workmanship

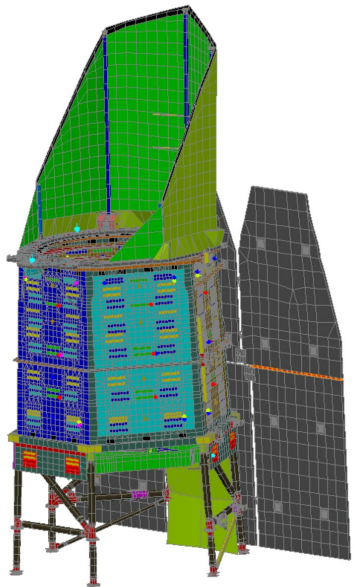

OBA, SASS-B,
DAC (deployed),

Flight H/W

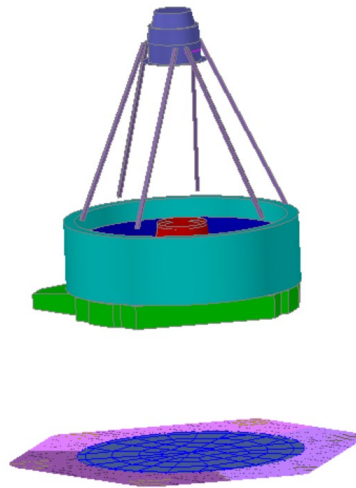

+

Second Mirror Assembly
SMSTs
Primary
Forward Metering Structure
AFT Metering Structure
Spacecraft Top Deck
Space Environment Simulator
(Chamber)

Test Ground Support
Equipment (GSE)

=

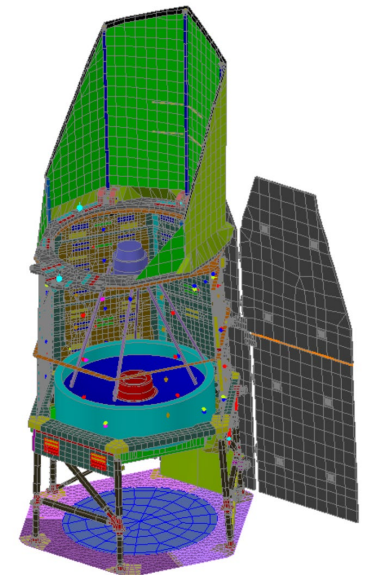

OSD Test



Example 2: Instrument Carrier Photogrammetry Test [K. McLean]



- The goal of the photogrammetry (PG) TVAC testing is to characterize thermoelastic behavior and verify the IC thermal distortion requirements can be met
- **Photogrammetry (PG)**
 - Photogrammetry is a measurement process that uses a series of pictures of a subject to triangulate and extract 3D data
 - A PG setup requires one or more cameras, capture images from different locations relative to the target
 - By recognizing the same element in multiple images PG software is able to extract 3D coordinates from the 2D images (through triangulation).
- **PG measurements at ambient and different cold temperatures provide data for thermoelastic model validation**

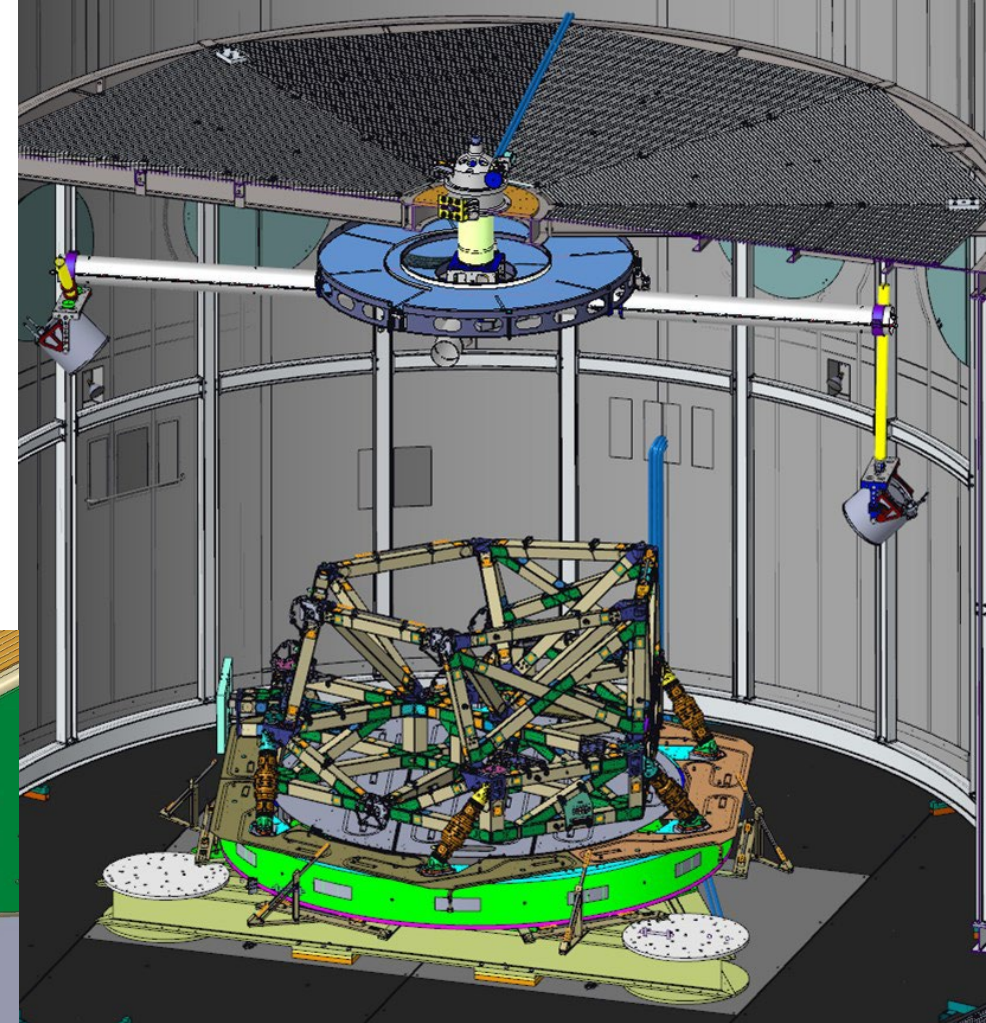
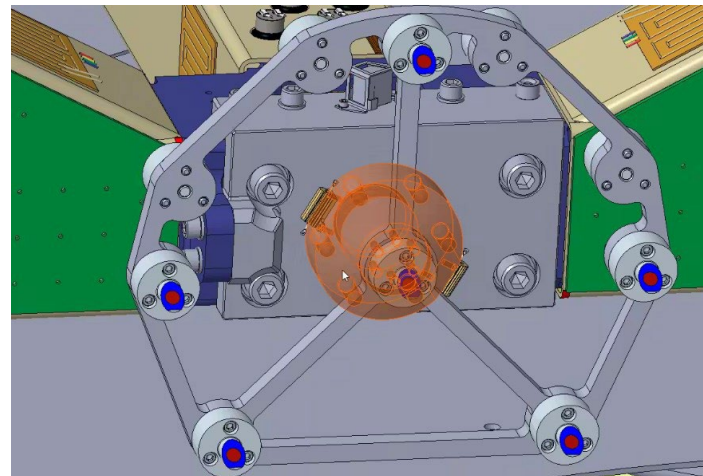



Example 3: SpaceCraft + Integrated Payload Assembly (SCIPA) Thermal Test Overview



- **The purpose of the test is:**
 - *Optical verification*
 - Thermal model correlation and cycling
 - System performance testing
- **The thermal environment for the test will be “flight-like”**
 - Analysis used to determine environment is adequate
- **Thermal test design for optical testing is often complex**
 - Must meet both thermal and optical test criteria
 - Cryo panels, heater panels, and flight hardware simulators to emulate flight-like conditions
 - Tighter temperature, gradient, and stability to satisfy optical test needs
- **Although the SCIPA test includes an optical verification, test will be designed to achieve thermal balance and will use the data to perform model correlation**

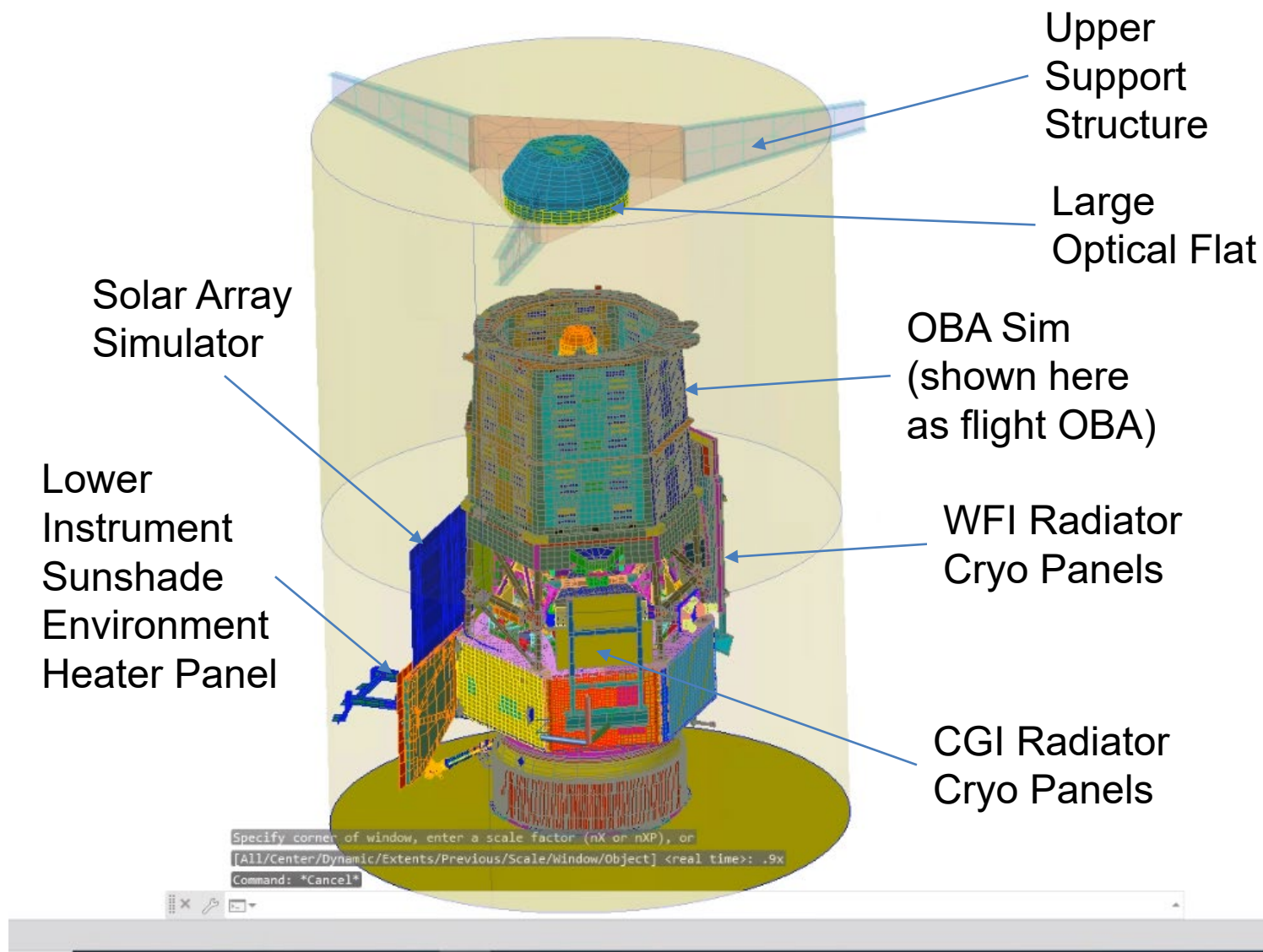



SCIPA TVAC Configuration

OLAFS (Optical Large Aperture Flat) – Mirror w Tip/Tilt/Focus Actuators and Vibration Isolation System.

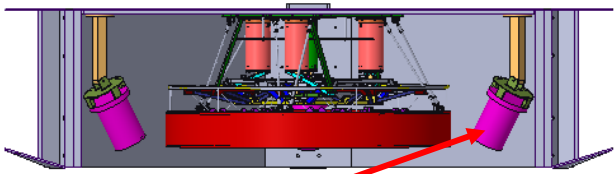

PG (Photogrammetry) Cameras (3X)

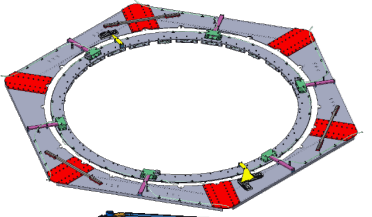

Top Deck Assembly (LED System)

OBA Sim Shell

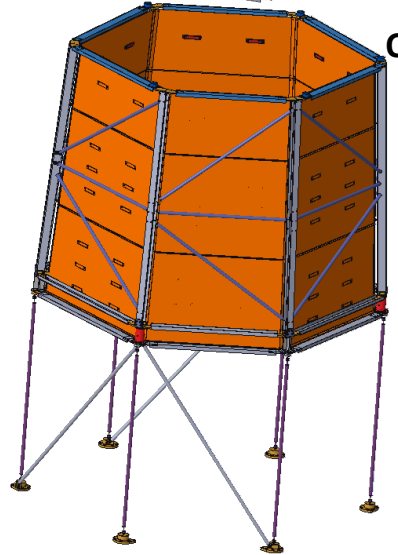

OBA Simulator Assy

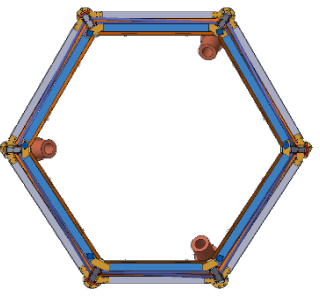

OBA Sim Elephant Stand

PG Cameras (3X)

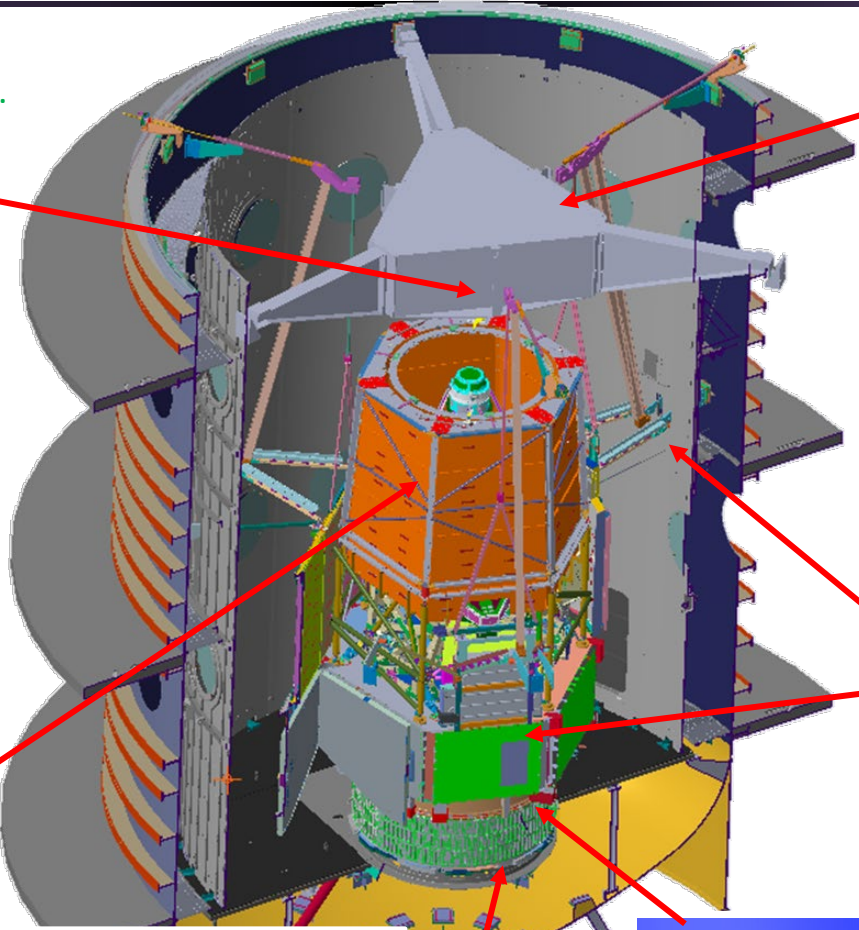

USF (Upper Support Frame) supporting OLAFS and 3X Photogrammetry (PG) cameras. SVEN Isolation

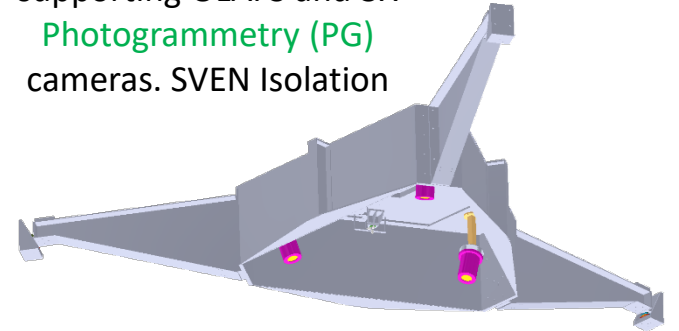

DSERS (Deep Space Env Radiation Sink) at WFI and CGI radiators. Utilizing chamber wall hard points. Similar configuration for SAS/LISS heater panels (not shown).

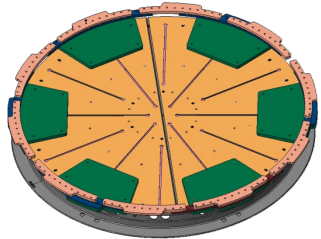
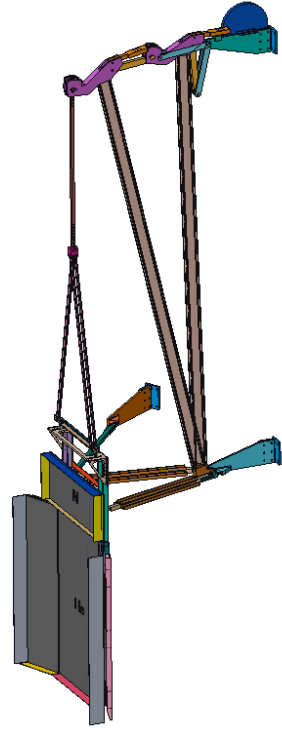

Payload Table Interface w/leveling

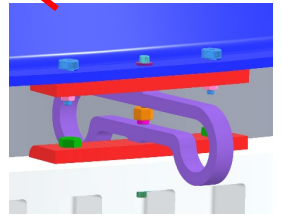

GVIS Ground Isolation

Non-thermal GSE



Wrap-up



Summary – General



- **Integrated modeling (IM) is a key capability for designing and testing optical systems at Goddard, including large space telescopes such as JWST and Roman. Typical Integrated Modeling analyses include:**
 - STOP/Thermal Distortion
 - Jitter/Vibration Isolation
 - Other Distortion Analyses: Gravity Release, Moisture Desorption/Dryout, and Invar Growth
- **Many of the requirements addressed by IM are either impossible or impractical to verify exclusively by test**
- **Thermal is a critical stakeholder to many aspects of IM work in supporting requirements verification by Analysis (A) and/or Test (T)**
 - (A) STOP modeling and analysis: Thermal portion of STOP
 - (A,T) Thermal and thermoelastic model validation: testing at temperature
 - (A,T) Optical requirement verification: testing at temperature
 - (A,T) Vibration isolation system and damper accommodations: dependency on temperature
 - (A) Moisture Desorption – dependency on temperature



Summary – Analysis



- **Managing the IM process requires multi-disciplinary coordination and collaboration**
- **IM Analyses are demanding:**
 - Thermal models need sufficient detail to be able to accurately map gradients and stability, which often results in increased model run time
 - The Roman Space Telescope approach of one model (not a separate detailed and reduced) does have the benefits of only needing to maintain one model with the penalty of increased run time
 - Any issues that can be identified by thermal prior to mapping (e.g. instability) can reduce the amount of rework if it is discovered later (e.g. better to catch issues prior to generating the end optical metrics)
 - Any designs with active control require modeling of controllers that is “good enough” while considering the impact on run time (e.g. small model timesteps to match H/W update frequency may not be feasible)
- **Mapping of temperatures requires:**
 - Good communication between thermal and structures (to define mapping groups)
 - Thoroughness by both thermal and structures to ensure that the correct temperature field is projected onto the structural model for thermal distortion. Careful attention must be paid to ensure that autoscaling and misalignments do not produce erroneous maps
- **IM process improvements depend on thermal modeling and analysis capability enhancements**
 - Shorten thermal analysis run-time (filtering Radks), possible model reduction or breakout models
 - Improved STOP mapping processes



Summary – Test Verification



- **IM also factors in to test development for requirements verification**
 - Thermal is involved with subsystem level testing to perform thermal balance tests to correlate subsystem models and provide confidence in their performance when integrated into higher level of assembly models
- **IM considers gravity sag and STOP/Thermal Distortion effects for verifying optical systems on the ground. GSE solutions to help gather data for IM model validation include:**
 - Cryopanel and Heater Panels to simulate the thermal flight environment
 - Source LEDs or other optical sources (such as a computer generated hologram)
 - Auto-collimating Flats (or other optical GSE)
 - Photogrammetry to measure distortion at flight like temperatures
 - Test sensors include thermistors, thermocouples, inclinometers, and accelerometers
- **Thermal is a key contributor to assess potential test configurations and predict the performance under flight like conditions during thermal vacuum testing**

INTEGRATED MODELING IS A CRUCIAL METHOD FOR VERIFYING REQUIREMENTS THAT ARE EITHER IMPOSSIBLE OR IMPRACTICAL TO VERIFY IN GROUND TESTING. THERMAL IS A KEY CONTRIBUTOR TO INTEGRATED MODELING, PREDICTING FLIGHT PERFORMANCE USING MODELS ANCHORED BY TEST DATA.