

The Design of the Low-Earth Orbit Flight Test of an Inflatable Decelerator (LOFTID) Reentry Vehicle (RV)

R.J. Bodkin¹, Robert L. Akamine², Hillary S. Blakeley¹, Paul F. Brewster³,
Dr. Neil Cheatwood⁴, Terry O. Clark⁵, Robert A. Dillman⁶,
John DiNonno⁷, Anjie L. Emmett¹, Sean M. Hancock⁸,
Stephen J. Hughes¹, Robert N. Mosher¹, Brian M. Saulman¹

NASA Langley Research Center, Hampton, VA, 23681, USA

Gregory T. Swanson⁹

NASA Ames Research Center, Moffett Field, CA, 94305, USA

¹ AST Aerospace Flight Systems, Mechanical Systems Branch.

² AST Electronic Instrumentation Systems, Electrical Systems Branch

³ AST Software Systems, Flight Software Systems Branch

⁴ Senior Engineer for Planetary Entry Decent and Landing, Atmospheric Flight and Entry Systems Branch

⁵ Engineering Technician, Mechanical Systems Branch

⁶ AST Aerospace Flight Systems, Atmospheric Flight and Entry Systems Branch

⁷ AST Aerospace Flight Systems, Engineering Integration Branch

⁸ Senior Engineer, Engineering Integration Branch

⁹ AST Aerospace Flight Systems, Entry Systems and Vehicle Development Branch

This discussion will involve the design and architecture of the Low-Earth Orbit Flight Test of an Inflatable Decelerator (LOFTID) Reentry Vehicle (RV). It will describe the structure and modular design of the RV, expounding on its various subsystems, including power and commanding, data handling and recovery, instrumentation, the inflation system, and the aeroshell. The unique launch vehicle architecture for the LOFTID mission, as a massive rideshare payload, required the development of supporting flight systems, including the Payload Adapter Separation System (PASS) and the Reentry Vehicle Payload Adapter Interface Ring (RVPAIR). To do no harm to the primary mission, the LOFTID team also designed and delivered a flightworthy Mass Simulator as risk reduction in the event the RV was not ready in time for the primary mission launch date. Various challenges and design trades will be discussed, along with a brief description of the RV performance in flight.

LOFTID was a secondary payload on the launch of JPSS-2 onboard an Atlas V launch vehicle. The following will discuss the design decisions of the LOFTID RV while highlighting decisions made for re-using previous hardware.

I. Introduction

The design and architecture of the Low-Earth Orbit Flight Test of an Inflatable Decelerator (LOFTID) Reentry Vehicle (RV) centered around using heritage from previous Hypersonic Inflatable Aerodynamic Decelerator (HIAD) flights and incorporating conventional spaceflight hardware in the avionics system where it helped balance the risk of a technology development flight. The design focused on robust support for the HIAD and making the overall RV robust and conservative in design. Over the course of the design work various additional support systems such as the Payload Adapter Separation System (PASS) and Reentry Vehicle Payload Adapter Interface Ring (RVPAIR) were added to the design to support vehicle integration with the launch vehicle. As a guarantee to our teammates, it was required early in the requirement that LOFTID provide a mass simulator in the event the RV was not ready to launch with JPSS-2.

II. Brief History of HIADs

The LOFTID was the continuation of the development of HIAD Technology. The quest for a deployable heatshield goes back to the mid 1960's with various crew rescue concepts and was researched for both manned and unmanned uses in starts and stops since then. The current HIAD research and development effort started in 2003 with the Inflatable Reentry Vehicle Experiment (IRVE) which launched on September 6, 2007. Unfortunately, the mission suffered a launch vehicle anomaly and failed to deploy IRVE from the launch vehicle payload shroud. In the middle of IRVE development in 2006 a ground development effort, the Program to Advance Inflatable Decelerators for Atmospheric Entry (PAIDAE) was stood up to investigate alternative materials and structural concepts to increase HIAD capabilities. This was followed by the successful flights of IRVE-II on August 17, 2009, and IRVE-3 on July 23, 2012. The flight that became LOFTID evolved multiple times between the flight of IRVE-3 and the final LOFTID mission that flew on November 10, 2022. IRVE-3 built 2 RV center bodies in the event of a failure. After the flight the IRVE-3 spare center body was assembled. The Langley Research Center (LaRC) portion of the center body was mated to the Sounding Rocket Program Office (SRPO) portion of

the center body at Wallops Flight Facility (WFF). It then performed various flight simulations to verify controls, transmitters, and data handling. This center body was for a short time called IRVE-4 for an enhanced sub-orbital test that was not funded, and the RV was disassembled with the LaRC segments stored at LaRC and the SRPO segments stored at WFF. Then a mission was given authority to proceed called Terrestrial HIAD Orbital Reentry (THOR) that was to fly on an Orbital Sciences Space/Orbital ATK Commercial Resupply Mission as a secondary payload. In the interest of minimizing cost, this mission would utilize as much of the IRVE-3/IRVE-4 hardware as possible. It also introduced several concepts such as a payload shroud jettison system using constant force springs, an ejectable data recorder, and reusing the inflation system from IRVE-3/IRVE-4. After the loss of the Cygnus Antares Orb-3 mission THOR was canceled. After THOR was canceled Bernard Kutter from United Launch Alliance (ULA) approached HIAD developers exploring a collaboration with NASA to design an engine recovery concept for the new Vulcan launch vehicle and a secondary payload opportunity for a HIAD flight experiment to further mature and demonstrate HAID technologies. This led to a proposal called HIAD on ULA (HULA). HULA then led to LOFTID, ULA and Launch Service Providers (LSP) working to identify vehicles with available up mass. Eventually the Joint Polar Satellite System-2 (JPSS-2) was identified as a potential candidate and ULA and LSP worked to get a commitment from the National Oceanic and Atmospheric Administration (NOAA) to allow LOFTID to be a secondary payload on their launch of JPSS-2 onboard an Atlas V launch vehicle.

III. Concept of Operations



Figure 1 – LOFTID Con-Ops image

LOFTID had a do-no-harm requirement levied on it by its partners at NOAA and ULA, consequently, there was not an option for pre-launch telemetry. LOFTID would launch powered off and inhibited and is not powered on until after JPSS-2 had separated from the Centaur upper stage of the Atlas V. Once the Centaur deployed JPSS-2 it would perform a collision and contamination avoidance maneuver and then perform a burn into a lower orbit to prepare for LOFTID's mission. The Centaur would then perform LOFTID's de-orbit burn, power on the RV, and the payload adapter that housed LOFTID under JPSS-2 would be jettisoned.



Figure 2 – Payload Adapter with JPSS-2 attached and LOFTID enclosed



Figure 3 – A view of the PASS as the Payload Adapter moves away from LOFTID

The Payload adapter had a ULA standard release system of short stroke springs at the base of the payload adapter, however, to assure the adapter cleared the aeroshell the PASS was added to the top of the payload adapter. It consisted of 6 constant force springs that would react off the top of the aeroshell to provide continuous application of force until the payload adapter cleared the RV. After payload adapter jettisoned the 4 pyro-technic cutters would be fired to release the packing restraint allowing LOFTID's Aeroshell to deploy and the inflation system would be commanded to begin inflation. Once the aeroshell had enough internal pressure to react the maneuvering loads the centaur would then reorient the RV into the correct orientation for reentry and spin it up to 3 RPM and the Centaur

would release the RV. After 13 seconds the RV's real time beacon would start to transmit data to the Iridium Satellite System and the vehicle would begin reentry shortly thereafter. At approximately 50,000 feet the Ejectable Data Module (EDM) was released from the RV using a spring-based system and a non-explosive actuator. At approximately 10,000 feet the parachute mortar would fire followed by activation of the recovery lights and the vehicle would activate the Locator Beacon (LB) and shut down its Real Time Beacon (RTB) to prevent possible interference since both systems utilized the Iridium network. Once the vehicle landed in the Pacific Ocean a salt water activated release mechanism would release the parachute and the recovery vessel would move in to attempt RV recovery. After RV recovery the recovery vessel would move to recover the EDM. Once ashore the data recorders data would be downloaded and dispersed to the team.

IV. RV Design

The design of the LOFTID RV was similar to the design of the previous IRVE vehicles. It was a modular design allowing the separate segments to be assembled and tested separately and then brought together during final vehicle integration. The RV was constructed in 3 segments. The Forward, Mid, and Aft Segments. The segments were joined by a Radial axial (Radax) joint, which has extensive heritage in the sounding rocket program and is a very robust joint to take radial and axial loads. The joint is relatively stiff and provides consistent responses to cycling loads.

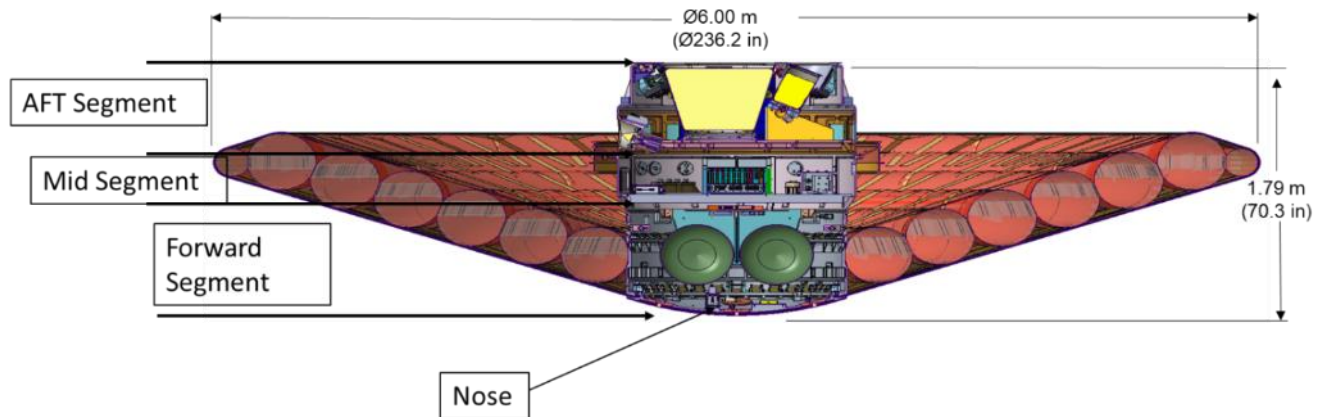

Figure 5 – RV Configuration

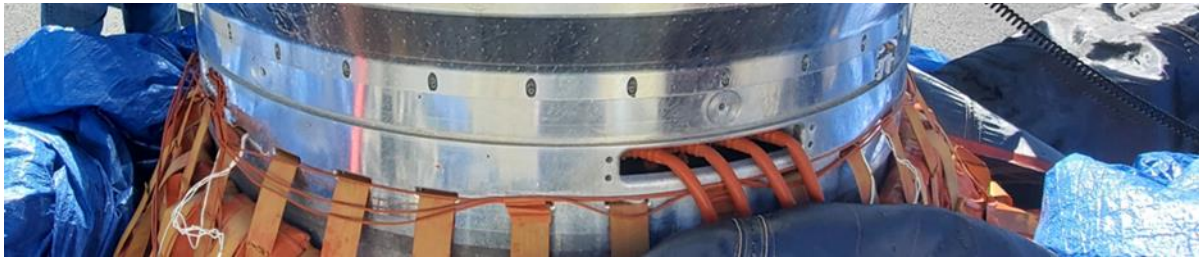

Figure 5 – Radax Joint between the Forward and Mid Segment

As part of the do no harm agreement with the primary payload it was required that LOFTID design a mass simulator in the event the RV was not available in time for launch so a modification of the control system of the Atlas launch vehicle was not required. The mass simulator was required to be completed before the final design of the RV was completed and as such had to provide a method to adjust the mass and adjust the center of gravity to replicate the flight RV. As such a method of shifting the center of Gravity (CG) axially and radially had to be incorporated. The mass simulator would use the same joint as the RV to mate to the RVP AIR for launch vehicle integration and was manufactured from Aluminum and Steel.

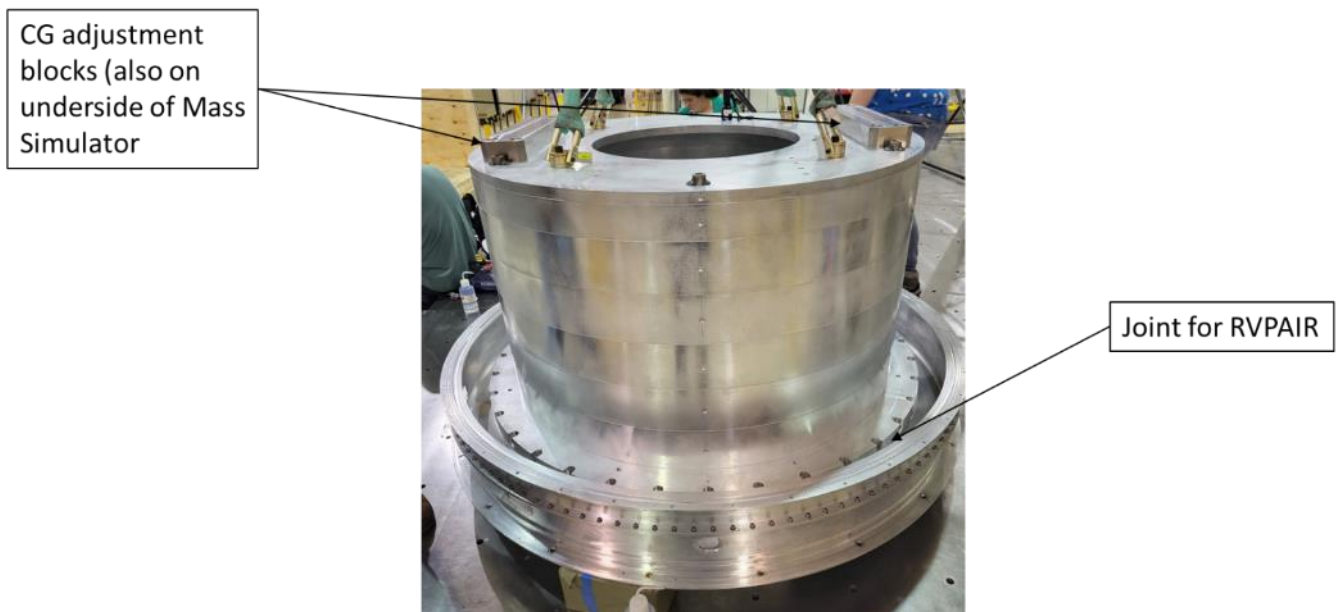

Figure 6 – Mass Simulator

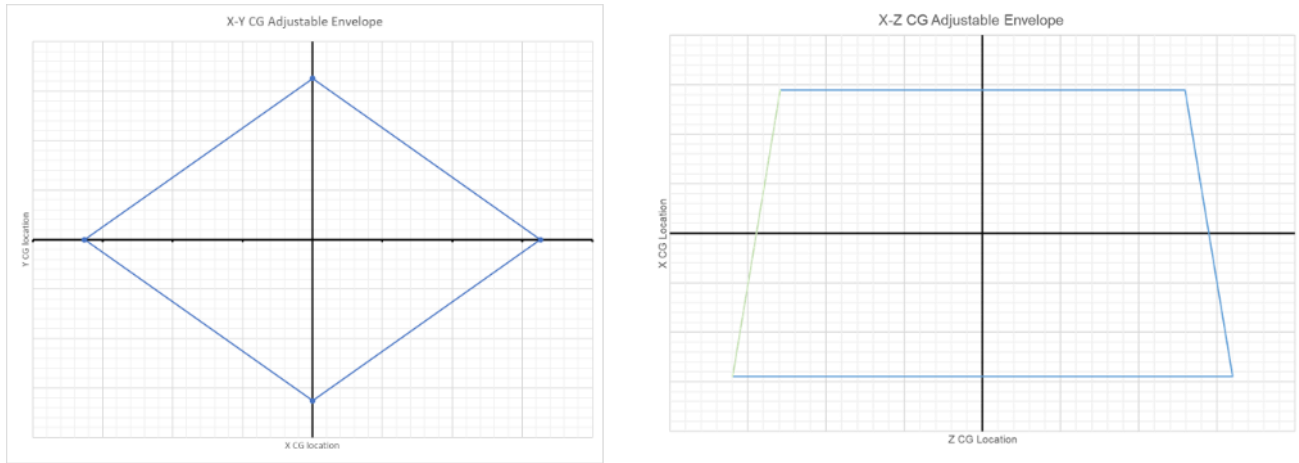

Figure 7 – Mass Simulator CG adjustable envelope

A. Forward Segment

The forward segment housed the inflation system, the mounting of the aeroshell, the Aeroshell Data Acquisition Unit (ADAU), total heat flux gauges, a radiometer, a set of pressure transducers measuring nose surface pressures configured to create a Flush Air Data System (FADS), the fill, and sense manifolds, the Broadband Reflectometer (BBR) for the nose Fiber Optic Sensing System (FOSS) fiber, a flag box, and the Rigid Nose. The BBR is required when the FOSS fiber transitions from the fiber that measures the temperature to the fiber that transmits the data to the FOSS without taking measurements. The forward segment also supported the aeroshell packing restraint and the pyrotechnic cutters that released the packing restraint. Mechanically the forward segment consisted of an Aft Ring, Forward Ring and 4 Mid-Segment Plates that were assembled to form the segment. This approach was utilized for manufacturability because the height of the segment would have been very expensive and had long lead times for the ring forgings. The large single piece would have also caused issues with the reach of the tools on the milling machines available at LaRC.



Figure 8 – Forward Segment

The aeroshell packing restraint is held in a Deadman's groove and closed with a Becket chain with a release loop that is routed through the pyrotechnic cutters. There are 2 cutter blocks on forward segment 180 degrees apart and two cutters per block. One cutter in each block is fired simultaneously.

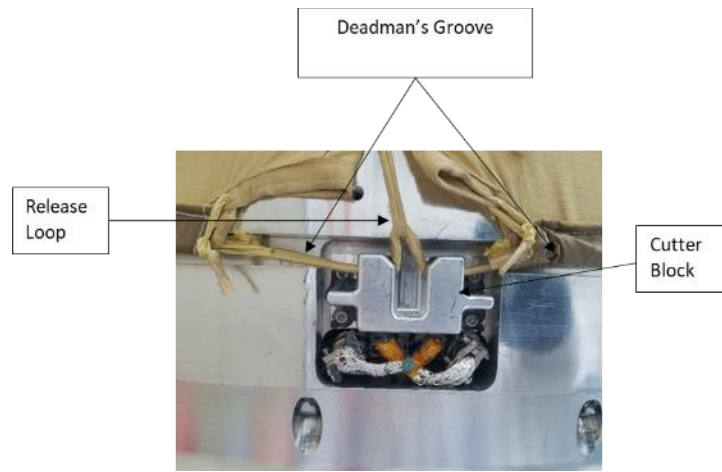

Figure 9 – Packing Restraint Release Cutters

It should be noted that the FOSS system was an experimental system to measure the temperatures on the RV that was managed by NASA's Launch Service Program and built by NASA's Armstrong Flight Research Center. The ADUA process the approximately 100 thermocouples on the aeroshell and was used to compare preflight predictions and understand aeroshell flight performance and anchor the FOSS data.

There were two fill manifolds to support the inflation of the aeroshell and two sense line manifolds providing pressure data on the inflatable tori used by the inflation controller in the Inflation System to provide data for the control system. The fill manifolds and the sense line manifolds were mounted roughly in 90-degree quadrants. The two fill manifolds incorporate a pressure transducer and relief valve in each per manifold. The relief valve to protect the aeroshell from an inflation system failure and allow venting of the tanks prior to recovery. The valves also allow venting of the gas from expansion due to a temperature rise in the gas from the heat of reentry. The manifolds included hot film anemometers to send a signal through the ADAU when the valves are open or closed.

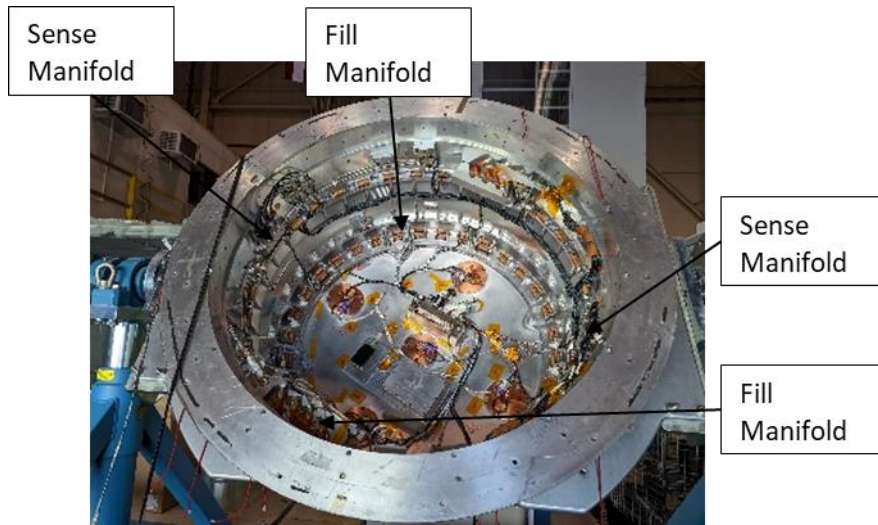

Figure 10 – Manifolds mounted in the Forward Segment

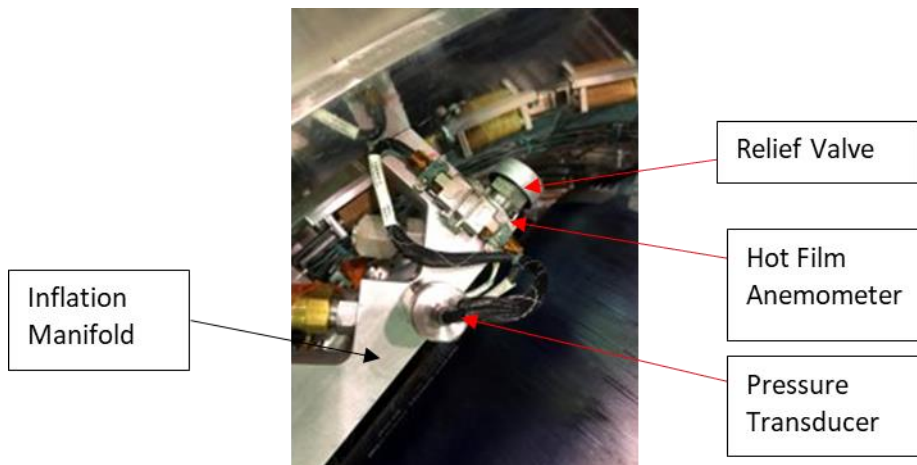
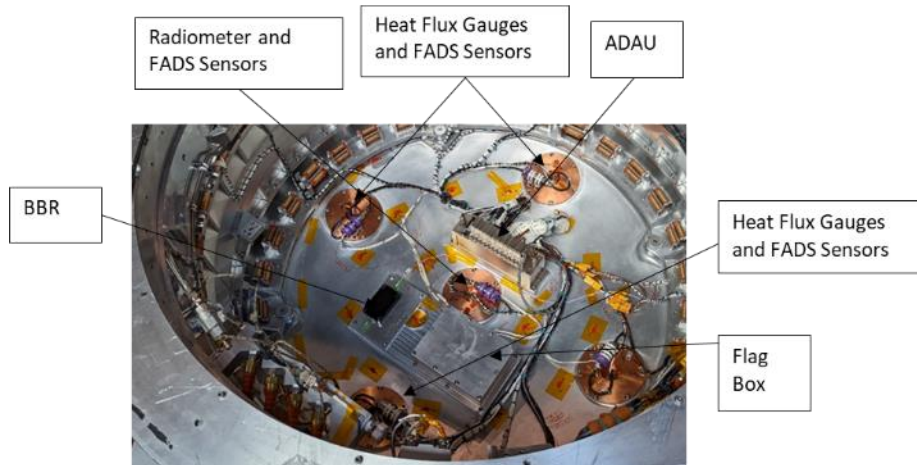

Figure 11 – Manifold installed

The Rigid Nose holds the four total heat flux sensors, five pressure transducers for the FADS, ADAU, BBR, radiometer, and Flag Box as shown below. The FADS pressure transducers are co-located with the heat flux sensors and radiometer. The rigid nose is covered with a flexible thermal protection system (FTPS) layer, but this FTPS layer was designed to challenge the FTPS since there was a rigid aluminum nose under it was designed with a more aggressive margining policy versus the FTPS on the deployable inflatable structure.



12 – Rigid Nose

The forward segment also included the interface for the manual valve 1 (MV1) launch lock to be installed during closeout to allow the pressurant to flow to the MFCV.

1) Inflation System

The LOFTID inflation System resided in the forward Segment. It consisted of 2 Composite Overwrapped Pressure Vessels (COPV) provided by ULA and the various valves, sensors, and controls to inflate the aeroshell. The inflation System utilized the hardware from the IRVE-3 Build-to-Print (BTP) that was stored at LaRC. IRVE-3 involved a new inflatable structure design that had additional inflation requirements than IRVE-II, therefore the inflation system was designed to support higher flow rates than were ultimately required to support the IRVE-3 aeroshell. The regulator required a new set point and initially an extra-check valve was installed in the system to allow the potential installation of a gas generator for an additional experiment on the flight. This option was not exercised on the flight and the valve was removed when there were issues with getting its compression seal to seal properly. It should be noted that with the sounding rocket heritage of the inflation system, most of the components were industrial and not space flight rated components. During discussions concerning on pad access and how long the vehicle may have to sit without maintenance it was decided to add a solenoid valve behind the servicing Quick Disconnect (QD) to provide a lower leak rate, and as fault protection for a failed QD, and thus fulfilled a do no harm requirement. The QD was in the RVPAIR for ease of servicing once integrated under the Payload Adapter.

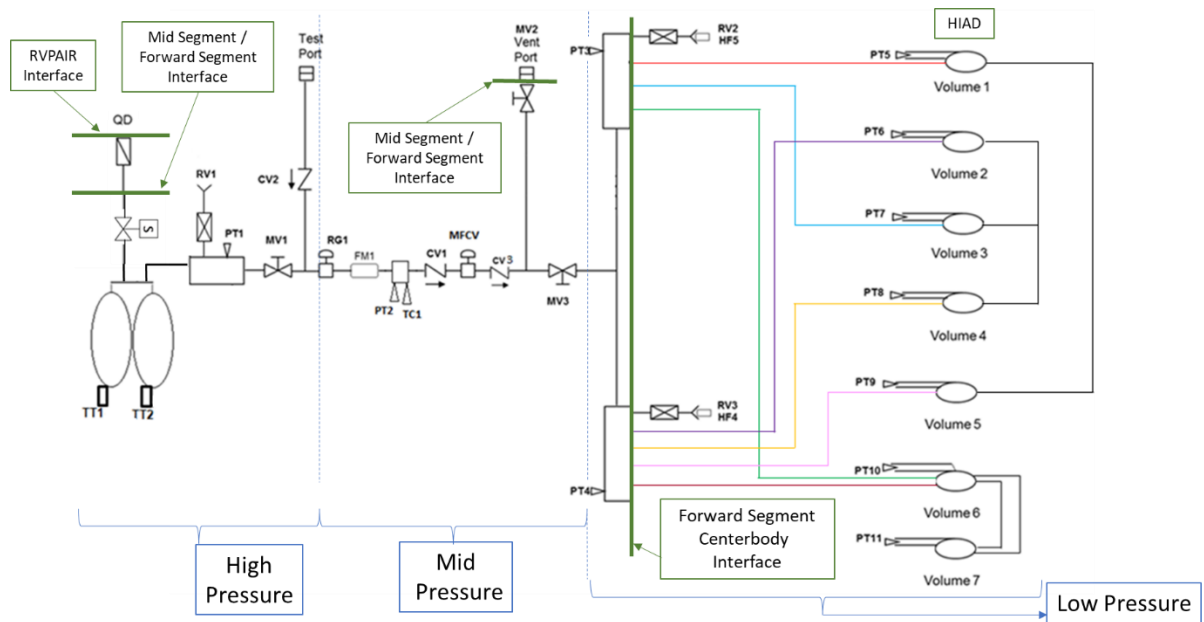

Figure 13 – Inflation System Schematic

The inflation system stored the pressurant in two COPV's at 3000 psia. The tank pressures were measured at a high-pressure manifold, but each tank contained a Resistance Temperature Devices (RTD) for gas temperatures. The tanks were mounted rigidly at one end but allowed to expand through a sleeve bearing at the other end. Downstream of the high-pressure manifold was a tank isolation manual valve. This valve prevented gas from moving down the system and was nominally closed during processing. It was locked open for flight. Beyond the manual valve, there was a test port that included check valve allowing the system to be tested with a high-pressure source, without putting cycles on the limited life COPVs. The test port was accessible through a port in the forward segment. The test port was capped for flight to protect against the failure of the check valve. The gas then moved to a regulator that stepped the pressure down providing a constant pressure through the majority of the mission. After the regulator the gas went through a turbine flow meter and a mid-pressure manifold that allowed temperature and pressure measurements to compute a mass flow for post flight processing. The next stage of the inflation system was the Mass Flow Control Valve (MFCV), which was controlled by the inflation controller. The MFCV was a linear control valve originally designed to replace pyrotechnic valves for other applications that was found to provide a relatively tight flow control being opened to intermediate settings. The MFCV had a Polyether Ether Ketone (PEEK) seat that would creep when kept closed, so during ground processing the MFCV was kept in an intermediate state of opening. Downstream of the MFCV, the gas passed by a check valve to protect the regulator from reverse flow during ground operations when the aeroshell was inflated by the vent/vac port. The vent/vac port allowed testing and inflating of the HIAD without the inflation system with external supplies, regulators, and valving. One item discovered during testing was pulling a vacuum on the Vent/Vac port would cause the HIAD Inflation lines to collapse and therefore an alternative way to vacate the HIAD was developed utilizing the sense manifold. The Vent/Vac port was a manual valve that was capped and locked closed for flight. The gas then passed through the Aeroshell Isolation Valve. This was a manual valve that prevented gas from going to the packed aeroshell to prevent inadvertent Aeroshell pressurization. During testing with a packed aeroshell it remained closed and was locked open for flight. The Aeroshell Isolation valve was the interface between the forward segment lines and the inflation

system. This allowed the forward segment and HIAD fill and sense lines to be leak checked and then packed with the inflation system removed from the forward segment for packing after the complete system test. Once the valve was closed and the inflation system installed in the Forward Segment it could be leak checked at that joint assuring the inflation system was bubble leak tight.

The inflation controller received two commands from the vehicle, a start inflation command and a dump command. Everything after those two commands were stored in the inflation system. The start command started an automated cycle that began with a soft start allowing gas to trickle into the aeroshell to unkink any lines. This lasted approximately 20 seconds and then the controller commanded the MFCV to full open for 25 seconds. After these 45 seconds, the MFCV enters a regulation state maintaining the tori to the set pressure. The second command received by the inflation controller is the dump command, which commands the MFCV to full open to drain any residual pressurant in the COPV to allow for safe recovery of the RV. The inflation controller utilized a Proportional–Integral (PI) controller to control the MFCV. The inflation controller was inhibited by a loop back connector on the payload adapter. When this connection was broken at Payload Adaptor Separation a relay would close allowing the Inflation Controller to issue command to the MFCV. As a precaution against any valve chattering, the inflation controller's idle state issues a close MFCV once a second. Additionally, there is an analog switch in the inflation system that allows simulated sense readings to be fed into the Inflation controller to verify its performance during ground testing without requiring an attached inflatable article. This is also utilized in final checkout of the inflation system during vehicle closeout when the inflatable flight unit is attached. Finally, Inflation System also contains the Inflation System Power Supply to provide the power needed by the inflation controller.



Figure 14 – Inflation System Installed in the Forward Segment

2) Aeroshell

The aeroshell is a stacked Torus structure. The tori nearest the center body that nests against it is referred to as T1 with the outermost shoulder tori referred to at T7. The aeroshell is a 70-degree half angle sphere cone that is 6 meters in diameter. The section diameter of the structural tori is 15.7 inches in diameter and the section diameter of the shoulder tori, T7, is 7.7 inches in diameter. The inflatable structure is manufactured from Zylon braid with a Teflon gas barrier to hold the inflation gas. The structure has an outer coating of Room Temperature Vulcanizing Silicone (RTV) to keep the braid organized until the aeroshell is inflated. Two Zylon cords provide in-plane stiffness to the aeroshell, and

the tori are connected to each other with an interference bond and paring loops. Zylon webbing is used to react the aeroshell drag load to the center body. The aeroshell has 6 structural tori and a shoulder torus which is a smaller radii torus to assure clean flow separation for stability. The tori have s 5/8-inch feed lines that connect to the fill manifold on the forward segment and the tori also have 5/8-inch gang lines that tie various tori together to provide for balanced inflation and provide some failure mode protection. There are 1/16-inch sense lines that connect the tori to a sense line manifold so that each torus pressure can be measured and provide those pressures to the inflation controller.

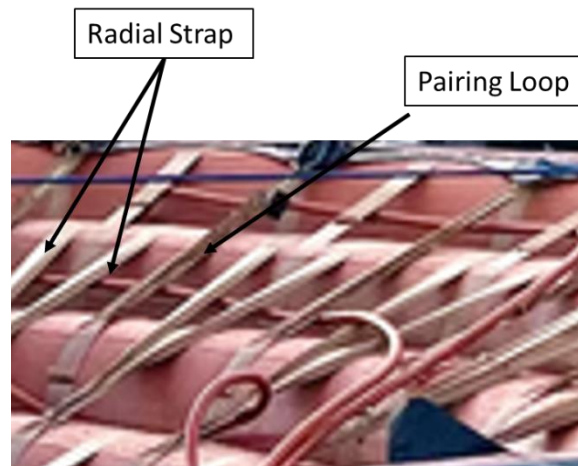

Figure 15 – Aeroshell Straps

The perimeter of the FTPS is anchored to the aft side Inflatable Structure with a cord loop and the forward side is mounted to a bar under the rigid nose. The FTPS is a quilted structure of Silicon Carbide, KFA5 and Pyrogel with a Teflon Zylon laminate gas barrier. The FTPS stopped on the aft side of the aeroshell at approximately midway around the T6 Torus.

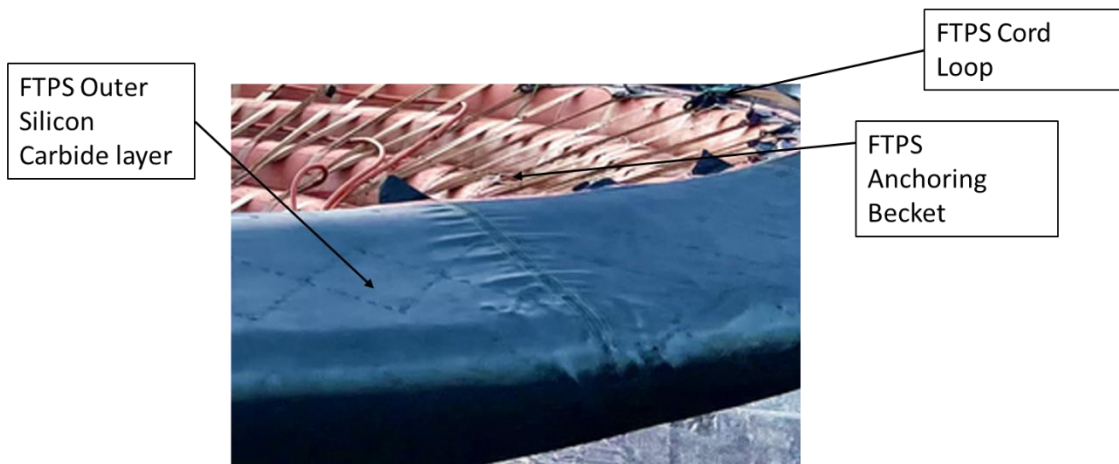

Figure 16 – Aeroshell FTPS Aft anchoring

The assembly of the Inflatable structure and the FTPS constitutes the deployable aeroshell or HIAD. The aeroshell connects to the Forward Segment with webbing straps through pin and clevis connections in 3 locations. There were four sets load cells pins aligned with the four cardinal directions that measured the interface loads during reentry. The aeroshell also has imbedded thermocouples to measure the temperature response of the FTPS and Inflatable Structure (IS) to reentry heating to assist with anchoring the LOFTID thermal model.

B. Mid Segment

The Mid Segment housed the majority of LOFTID's avionics. Mid segment was an open cylinder that had a deck plate for mounting the avionics and pass throughs for the inflation system fill line to pass from the forward segment. The Mid Segment provided pass throughs to the aft segment for the power, commanding, and data lines. The Mid Segment housed the RVP AIR, which was the interface between LOFTID and the launch vehicle. The RV pair housed also housed the connectors needed to charge LOFTID's batteries and perform checkout and test functions and contained the arming plug for the pyrotechnic system. The loop back connectors also were located on the RV pair as part of the inflight disconnects. The RVP AIR was provided by ULA with the LOFTID team providing input for our ports and connectors.

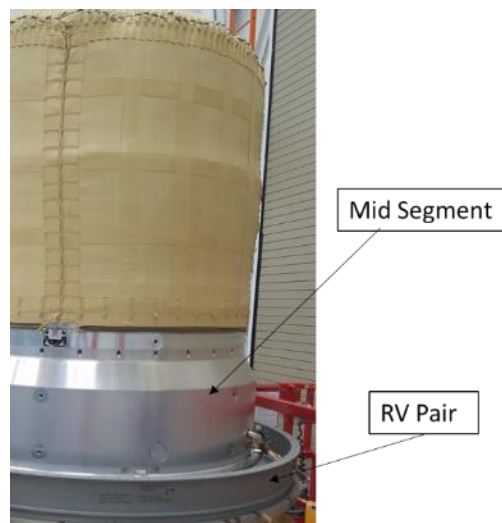

Figure 17 – Mid Segment with RV Pair

The mid segment also had a FOSS Fiber and Thermocouples on the outer skin to get an idea of aft side payload heating during the flight. This was thermally isolated to minimize heat sink to the RV segment.

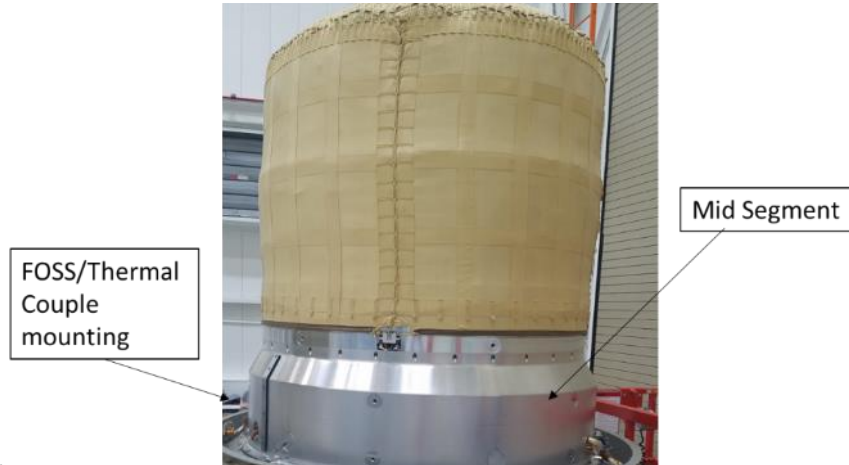

Figure 18 – Mid Segment FOSS Thermal Couple Mounting

The Mid Segment had three hatches to remove the System Battery, Pyro Battery, and the Internal Data Recorder (IDR) post flight. The Mid Segment also housed the MV1 and MV2 Launch locks.

1. Avionics

The Avionics System of LOFTID touches all aspects of the vehicle, but most of the system resides in the mid-segment. LOFTID decided early in the project that it would lean on pre-qualified hardware to save time qualifying components. Range rules also quickly made clear that having batteries with heritage on the range would smooth out the approval process for the vehicle. LOFTID's avionics team utilized serial converters and DC/DC converters from IRVE-3 BTP/IRVE-4 hardware. The Inflation Controller DC/DC converters, and serial converters were the only LaRC designed avionics used from previous HIAD flights. The LOFTID avionics utilizes an off the shelf Modular Avionics Control Hardware (MACH) system, with flight heritage on expendable launch vehicles, to serve as the event controller and flight computer. The System Battery, which is the primary electrical power source for electrical/electronic components, and Pyro Battery, which provides surge current to fire the Electro-Explosive Devices (EED) and Non-Explosive Device (NED), were qualified components for more extreme launch and operational environments. A giga-bit Ethernet data switch as procured, flight qualified, and flight accepted by Marshall Space Flight Center (MSFC) and delivered to LaRC. The ADAU was a COTS component, managed by MSFC, with qualification test heritage and this unit obtained the ~100 measurements required for this flight demonstration. MSFC also designed, qualified, and delivered the camera pods. Each camera pod

consisted of two IR cameras, one HD visual camera, and a single board computer assembly. COTS products without clear flight heritage to relevant flight environments, and custom designs, were qualified as needed. LOFTID was designed to rely on a two-sigma event timer scheme for vehicle control, so the timeline ran without relying on any feedback for the next event. The MACH also receives, buffers, uses, and forwards the inflation systems data, the Global Positioning System (GPS) data, and the Inertial measurement Unit (IMU) data. It routes data to the network data switch which then routes the data to the IDR and EDR. The MACH also routes minimum, essential data to the RTB to transmit to ground and recovery operations. The pyrotechnic safing and arming are controlled by the MACH and Ordinance Arming Relay Assembly (OARA). This was another decision to provide confidence to our partners that we were using an ordinance controller with flight heritage as part of our do no harm strategy. The forward segment pyrotechnics are inhibited until the payload adapter is released. The aft segment pyrotechnics are inhibited until vehicle separates from the centaur. There is an Interface Adapter Unit (IAU) that provides the main relays that are activated by the launch vehicle signal to powers the RV on. The IAU connects the Pyro and System Battery to the MACH. The IAU also receives the loop back signals from the launch vehicle and conditions them for the MACH. Finally, the IAU conditions the RTD in the vehicle, mainly in the inflation system. The Armstrong Flight Research Center (AFRC) FOSS box and the mid segment BBR are also housed in the mid segment.

The FOSS is an experiment that LOFTID is hosting designed by AFRC with support from an LSP Principal Investigator. The LOFTID team analyzed failure modes of the FOSS to make sure any of its failure modes would not harm LOFTID or drain its system battery and it was determined that FOSS posed no risk to LOFTID. There is an Internal Data Recorder (IDR) that is the same hardware that is used in the EDM, but the internal batteries are discharged, and it utilizes power supplied by the RV and none of the beacon functions were activated. The Mid Segment had an IMU. The IMU's qualification data did not encompass the LOFTID environments, however reviewing qualification data from NSROC, which flies the units outside the vendor qualification range, it was determined that there was little risk to the unit and the decision was made to fly it and not perform any component level qualification testing of the level from the confidence gained with that data.

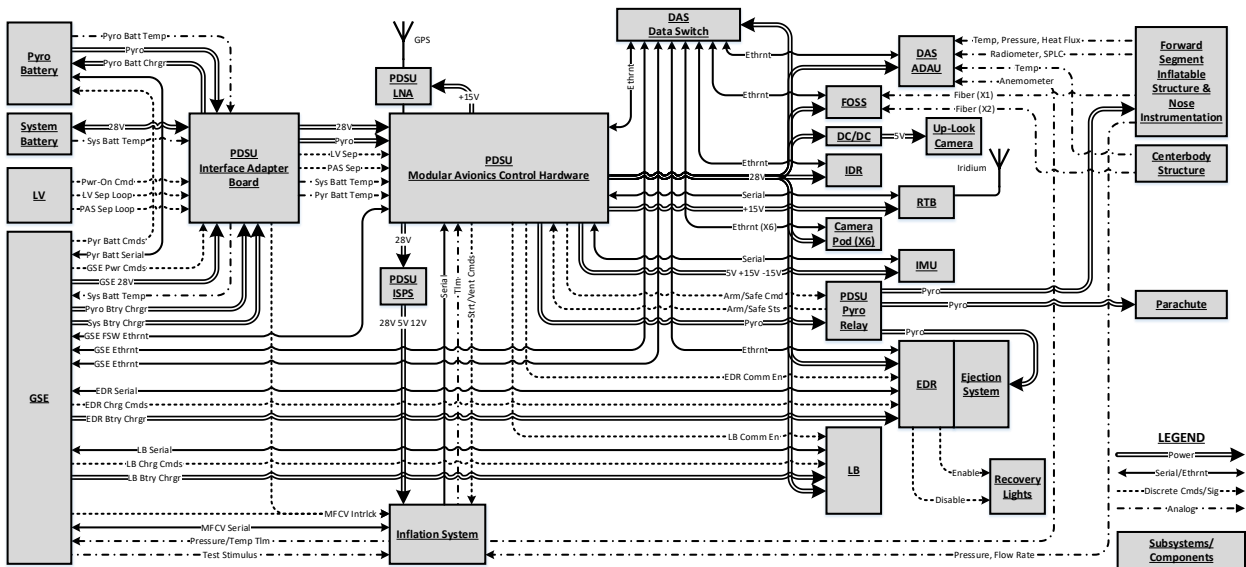

Figure 19 – Avionics Interconnect Diagram

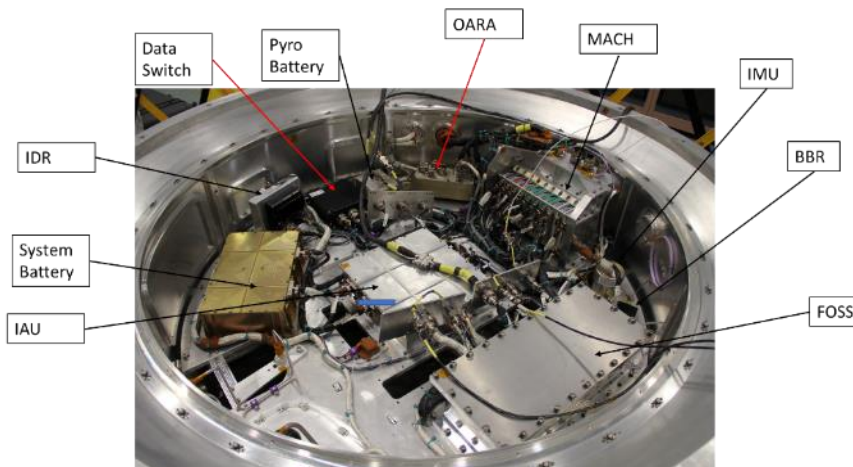

Figure 20 – Mid Segment Configuration

2. Flight Software

LOFTID Flight Software consists of three components: the MACH Software, the Data Recorder Software, and the Camera Controller Software. The MACH Software interfaces with and controls the other avionics devices, operates the pyrotechnics, performs data acquisition, downlinks telemetry via the Iridium modem, and executes the mission timeline. The Data Recorder Software receives the data from all the avionics devices and stores the data in a recoverable file system. The Camera Controller Software receives video from a visual camera and two Infra-Red cameras, records the data to local storage, and streams the video to the Data Recorder.

To both ease development and enhance reliability, the three software components were based on mature software frameworks and libraries. The MACH Software was based on the NASA developed Core Flight System (cFS), a modular, layered platform for real-time flight applications that has significant flight heritage. The Data Recorder Software was based on libPCAP, a widely used open-source library designed for network traffic capture. The Camera Controller Software was based on GStreamer, an open-source multimedia framework with hardware support for encoding and decoding of video streams.

LOFTID Flight Software was developed over six build cycles, with each cycle ending in a code review and formal test for requirements verification. Each build cycle formal test also included regression testing of requirements verified in previous builds. The last build cycle included the final builds of all software components, verified all software requirements, and served as the Software Acceptance Test

C. Aft Segment

The Aft Segment contained the recovery systems, the Camera Pods, and the antennas and transmitters for the beacons on the vehicle and the GPS Low Noise Amplifier (LNA). It was comprised of two ring cylinders, the Aft Segment Ring which interfaces with the Mid Segment and the Aft Interface Ring, which contains the camera pods, which is tapered to avoid keep out zones on the launch vehicle. While designing the vehicle the Aft Interface Ring was stretched to give the camera pods additional views of the aft side of the aeroshell. The Camera Pods was designed by MSFC. There were 6 camera pods. Each camera pod included 1 visible light camera and 2 IR cameras and a LED ring to illuminate the aeroshell during darkness. The camera pods sent compressed video to the data recorders but stored higher quality onboard the pod's single board computer that would be available if the RV was recovered. There was an up-look camera that was a late edition to the vehicle that stored its video internally to itself but was not integrated to the vehicle's data system and that camera's video would only be available if the vehicle was recovered. This camera was a commercial off the shelf (COTS) unit originally developed for the Orion Spacecraft that included an illuminator LED. During testing it was discovered that the illuminator LED reflected off the window the camera looked through. The LED was eventually epoxied over to prevent it from washing out the captured video. The intent of the up-look camera is to observe launch vehicle separation and capture parachute deployment. The Aft Segment also includes the mounting provisions for the ballast to balance the RV. The Aft Segment Ring has 8 small access hatches and 3 large access hatches to allow access to the vehicle to add or remove hardware during late integration. The aft end of the vehicle had FTPS substrate plates to mount the GPS antenna and the Iridium antenna. The substrate plates also provided a mounting surface for the FTPS to protect the aft end of the vehicle from wake heating. The Iridium antenna was part of the RTB system to provide a minimum data set in the event the RV and EDM are unable to be recovered. The plan was that the RTB would give information that the RV was properly oriented and the aeroshell was at design pressure for reentry and then prove that the RV successfully survived reentry. During the course of the design, it became readily apparent that the secondary payload nature of the RV could not guarantee ground stations to transmit data to. The FTPS on the aeroshell is radio opaque, which would have provided challenges even if there were ground stations. The low bandwidth omni Telemetry and Data Relay System (TDRS) was researched and was eliminated from the trade space because it had too low of a data rate to support even the minimum data set. The high-bandwidth TDRS link was in line with transmitting the full data set, but the requirement of a pointing antenna added complexity to the vehicle, and it would have violated keep out zones with the launch vehicle. This led to the selection of the Iridium burst data being selected for the RTB data. There was a mounting plate installed in the Aft

Segment ring to support hardware mounting. There was also a FOSS fiber and thermal couple installed in the aft segment and under the Aft FTPS similar to the Mid Segment.



Figure 21– Aft Segment

1. Ejectable Data Recorder (EDR)

The EDR was a two-part system consistent of the EDM and the ejection system. It was designed to store the data and then be ejected from the vehicle at approximately 50,000 ft. The EDM was hardened to free fall and splash down in the water. It was designed to float for 30 days and broadcast its locations over both the Iridium network and a Long Range (LoRa) network. The LoRa system would update faster than the Iridium network and as the recovery vessel approached the EDM would transition from Iridium tracking to LoRa. The LoRa system relied on repeaters that were launched on weather balloons to increase its view over the horizon to support recovery. The LoRa system reported to handheld ground stations that provided pointing guidance to the EDM. The EDM was approximately the size of a softball. The stud used to retain the EDM in the ejections system also acted as a keel to keep the antennas pointing up even during rough seas. The ejection system was designed using a spring mechanism to launch the EDM. The ejection system was actuated by a Non-explosive Actuator (NEA). Even though the NEA was not technically a pyrotechnic device LOFTID elected to treat it as a pyrotechnic device since it contained a large amount of energy. This was in line with the do no harm mentality that governed all design decisions protecting our primary payload partners. The EDM proved to be a robust system that was utilized as the EDM, IDR, and the LB for recovery. The LB did not utilize any of the data recovery equipment, but relied on the Iridium transmitter, GPS receiver, and LoRa transmitters to recover the RV post landing. The LB was independent of the RV avionics systems for power once it was activated. This was necessary since the RV's avionics did not utilize hermetic connectors and therefore could not be relied upon once the vehicle was in the water.

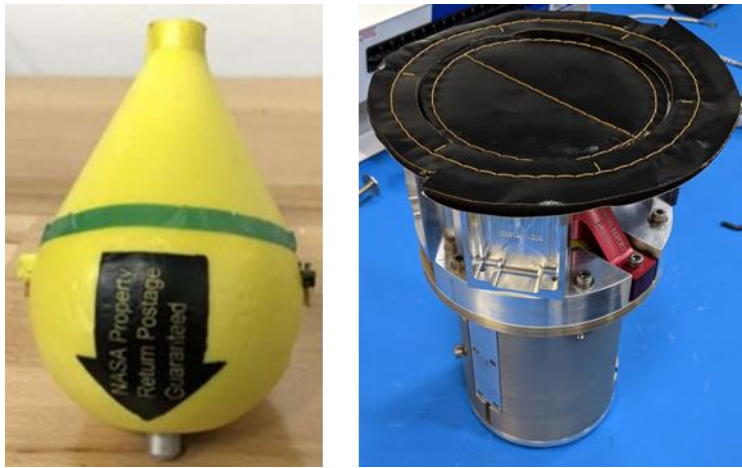

Figure 22 – EDM on the left and Ejection Mechanism with the FTPS installed on the right (note not to scale)

2. Recovery Aids

The vehicle had various recovery aids to aid in locating the RV once it was in the water. The first recovery aid was the parachute. It was designed to slow the RV. It was 94 Ft in diameter and was deployed by a mortar fired pilot parachute. The mortar was propelled by a gas generator. The parachute was reefed by a pull pin reefing cutter that were on a delay. The pin was pulled during the deployment of the parachute. One of the concerns during the design was the risk of the parachute dragging the RV underwater if it was losing pressure after landing. This risk was mitigated by utilizing a saltwater release of the parachute once the RV landed. There were pockets in the parachute to aid sinking after landing. The parachute system was provided by ULA as part of their contribution to LOFTID. The RV also had an independent recovery light system designed by Ames Research Center (ARC), that was hermetically sealed. This system was activated by the RV avionics, but then was fully independent for both power and control from the avionics. This was again to protect that system from any unplanned shorting of the avionics system as it was immersed in water. In the event the RV was in the water and the recovery lights failed there were 4 corner cube reflectors mounted on the aft interface plane. This would allow the RV to reflect light if the recovery ship was required to utilize search lights to find it. The RV had 2 stable orientations in the water. The preferred orientation would be nose down and would expose the beacons and recovery lights and corner cube reflectors. The other orientation was nose up, which would put all the recovery aids underwater. To mitigate this risk the aft segment had a sonar beacon that is similar to the beacons on aircraft black boxes to aid in locating the RV in the event it landed nose up. These beacons have been used all the way back to IRVE and aided in finding the IRVE RV after the launch anomaly.

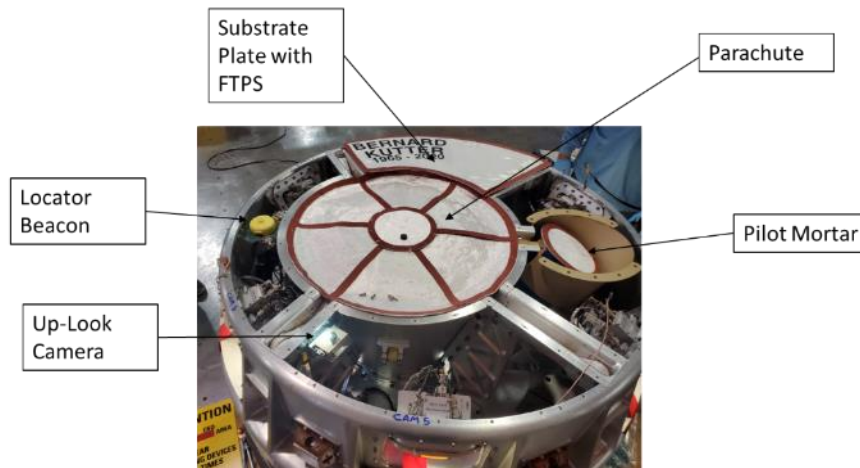

Figure 23 – Aft Segment Recovery Aids and layout

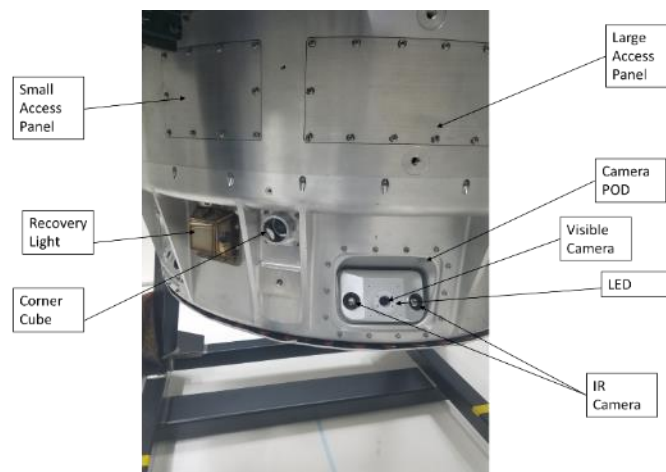

Figure 24 – Aft Segment Recovery Aids and layout

V. Brief Description of Flight Results

The RV launched on November 10, 2022, with JPSS-2 from Vandenberg Space Force Base (VSFB) and performed its reentry and landed off the coast of Hawaii. LOFTID re-entered at Mach 30 and was the largest blunt body to ever successfully reenter an atmosphere and survive. The vehicle successfully executed its timeline and landed approximately 5 miles from recovery vessel. The EDM landed within 6 miles of the recovery vessel and was also successfully recovered. The Iridium network proved not to be as reliable as hoped and no RTB packets were received prior to reentry. The only RTB packets that were received were after the RV was subsonic and near parachute deployment. The FOSS fibers in the nose were only expected to survive 800°F, but returned flight data showed the system remained functional to

approximately 1000°F. The data returned also correlated well with the collocated thermocouples. The Mid and Aft Segment showed temperatures that did not rise over 98.6°F demonstrating the aeroshell effectively protected the payload. There was a software anomaly that resulted in the inflation system data, GPS data, and IMU data not being recorded to the data recorders. The MACH did not see the data switch during its boot sequence, because it wasn't fully initialized. The MACH continued its boot sequence and never initialized the port. It did not return to the port after booting. This issue was masked during ground testing as the ground support equipment (GSE) was seen as the network connection. The need to monitor battery voltages and temperatures, inflation system pressures, and Iridium connections and needing to verify the MFCV was through its built-in test (BIT) led to a plug out test never being performed on the flight RV and was an oversight in developmental testing. The RV looked fairly pristine post flight. The only indication of any heat on the RV was on two components on the RVP AIR. There was a piece of Kapton tape scorched and a small blister on a Tygon tube to support the FOSS box. Otherwise, the vehicle looked pristine and almost like it had not flown except for salt spray on the exterior.

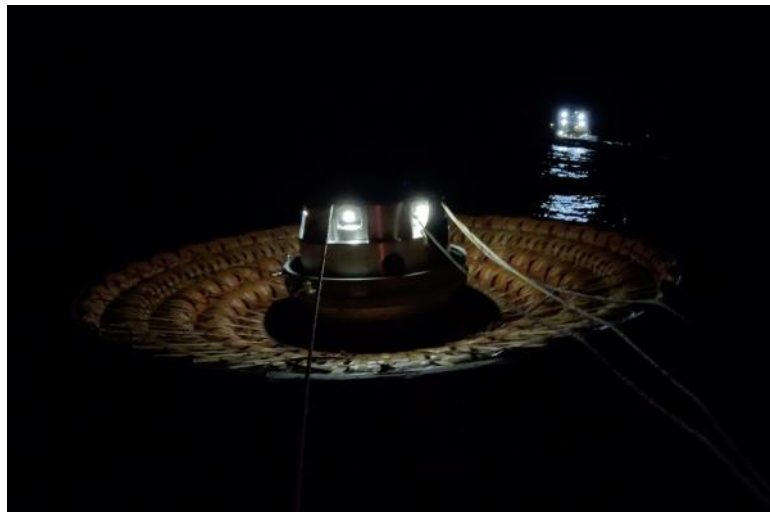

Figure 25 – LOFTID seen from the small recovery boat with the main vessel in the distance



Figure 26 – Left is Blistered Tygon Tubing and Scorched Kapton Tape on RV Pair

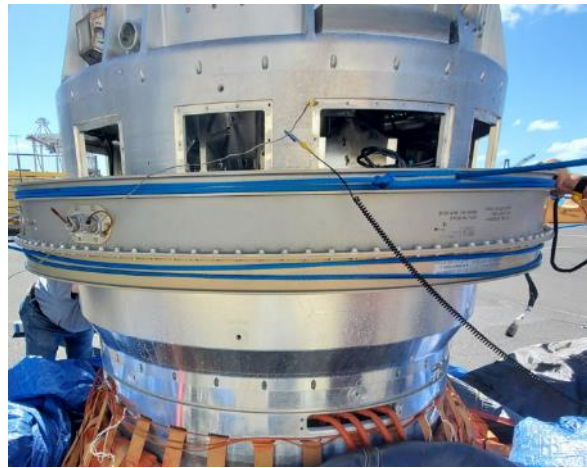

Figure 27 – RV Center Body Post Flight



Figure 28 – RV in Hawaii post flight showing condition of the RV

VI. Conclusion

This was a basic discussion of the design of the LOFTID RV providing insight into some of the decisions that governed the design. The vehicle was based upon the previous flights of the IRVE series of vehicles and where applicable leveraged heritage of those vehicles to minimize new designs and testing. LOFTID successfully demonstrated that a HIAD can protect a payload re-entering from orbital velocity. It successfully reentered at Mach 30 and demonstrated the HIAD technology.