

Heritage to Flight: The Test Program that Brought an Inflation System Back to Life for LOFTID

H. Blakeley

NASA/D202

AIAA SciTech, Jan 8-12, 2024

Published by the American Institute of Aeronautics and Astronautics, Inc., with permission.

HIAD Technology

Hypersonic Inflatable Aerodynamic Decelerator

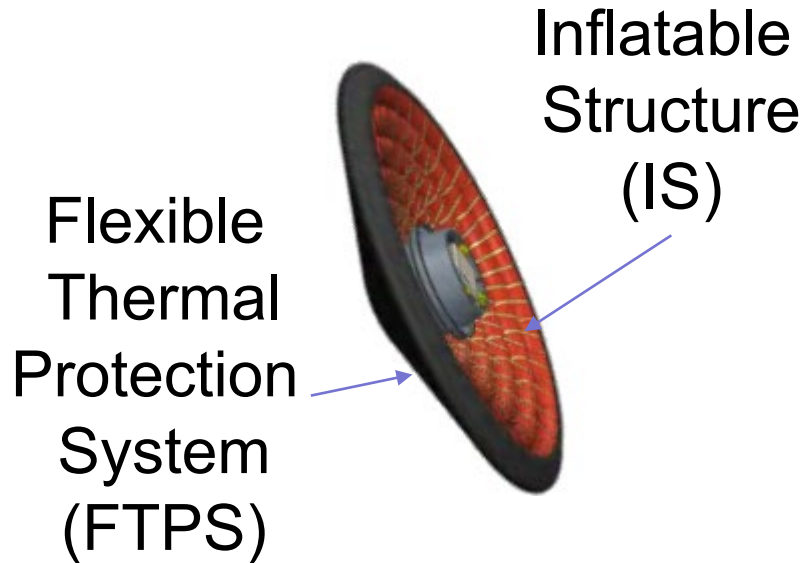

HIAD Successful Flight Tests

3m Diameter:

- IRVE-II, 2009
- IRVE-3, 2012



6m Diameter:

- LOFTID, 2022



LOFTID



IRVE vs LOFTID

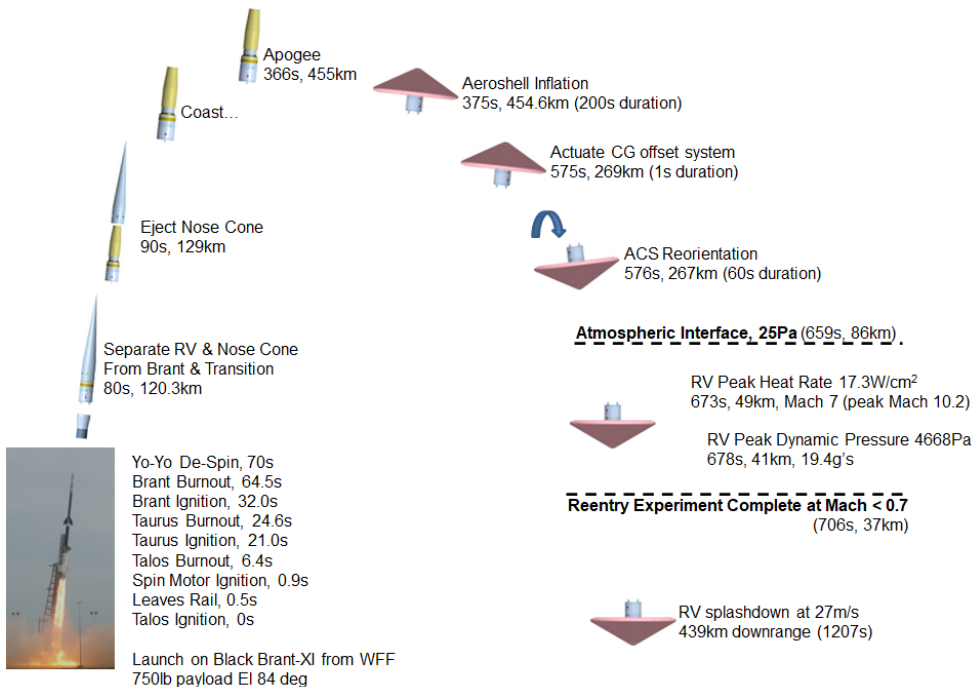

LOFTID Inflation System

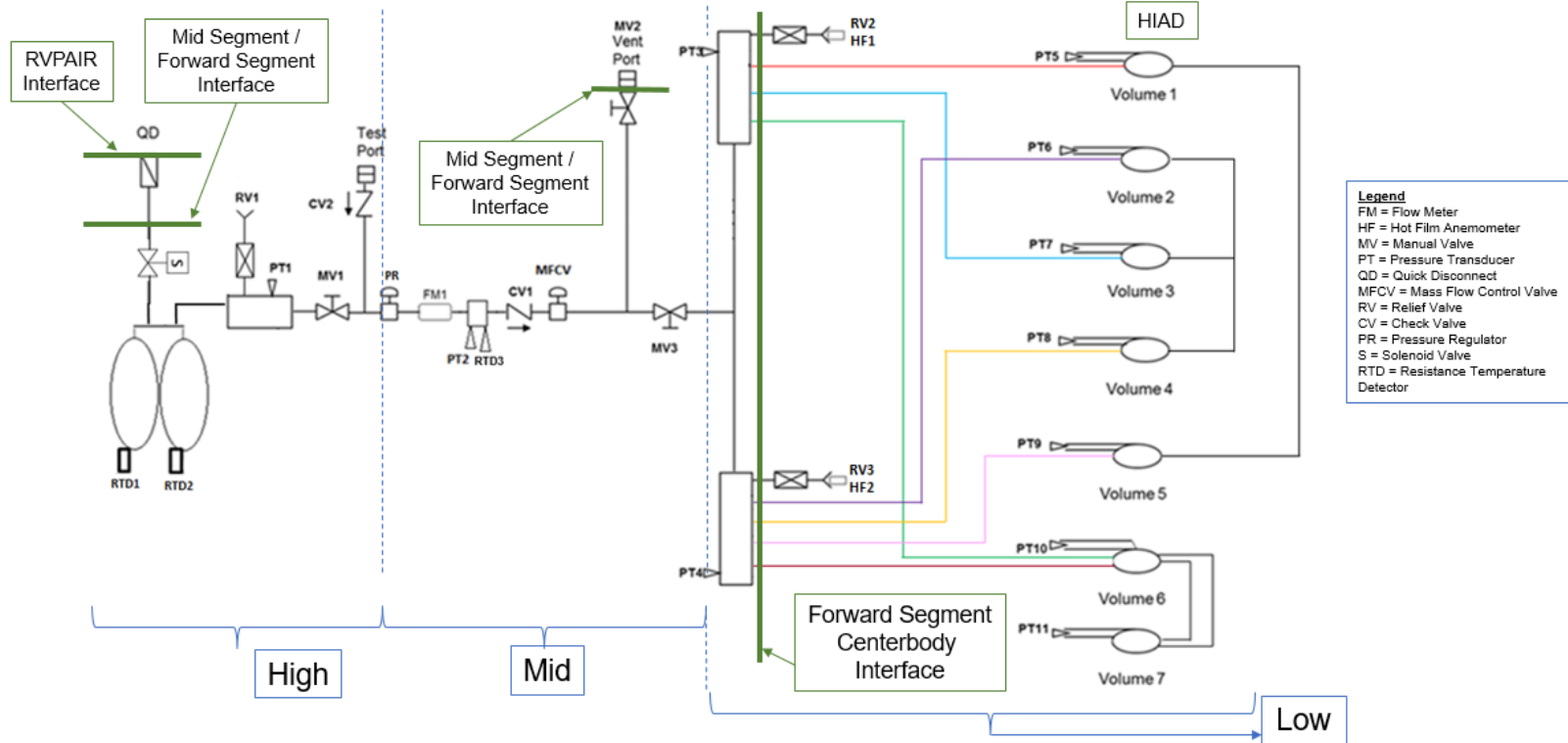

IRVE-3 vs LOFTID Centerbody

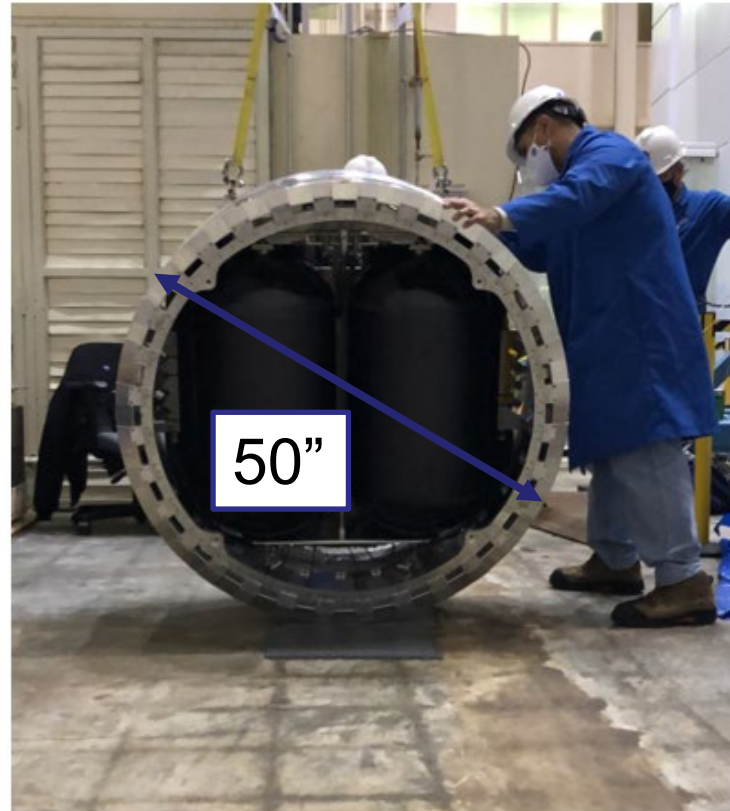
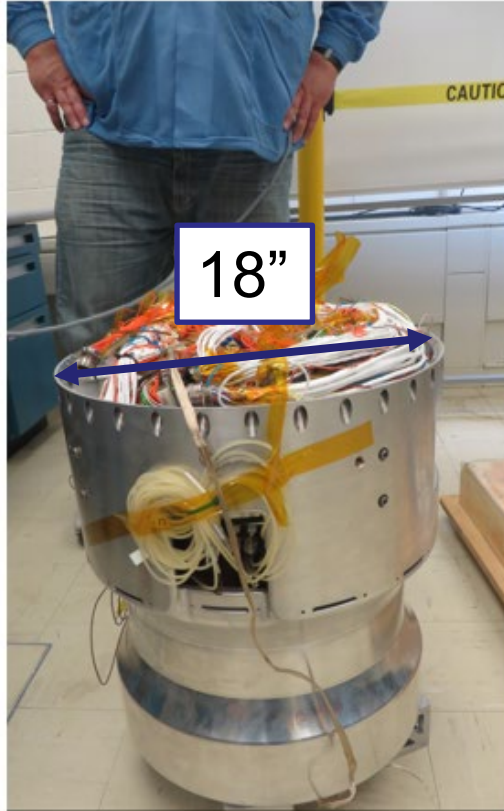

IRVE-3 vs LOFTID Inflation System

IRVE-3 Pneumatics Plates

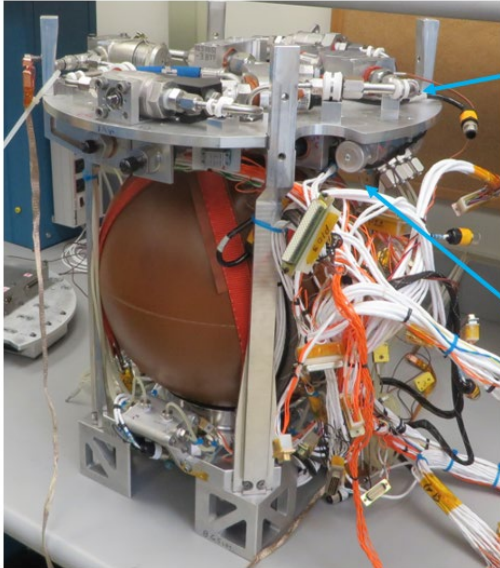

Top of Inflation Plate

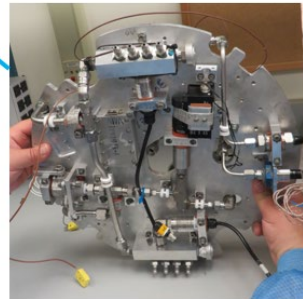

Bottom of Inflation Plate



LOFTID Pneumatics Plate

Test Campaign, Phase I

Component Level: Sealing, Pressure Capability, and Flow Characterization

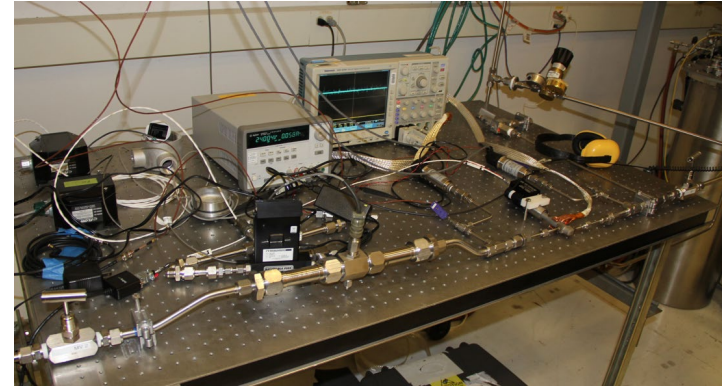
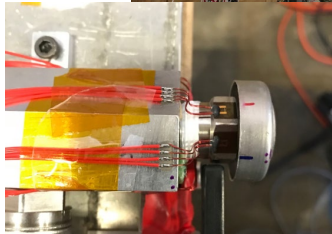
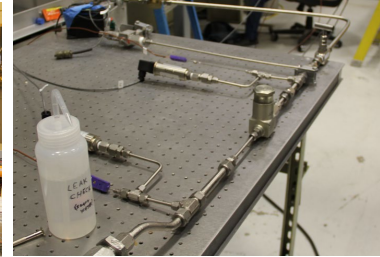
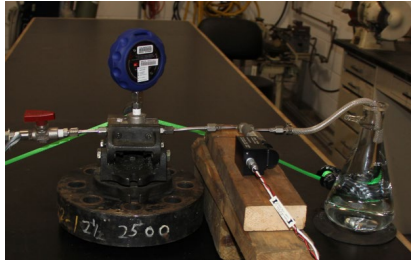

Test Campaign, Phase II

Subsystem Level: Flow Characterization, Leak Checks, Functionals, Vibration

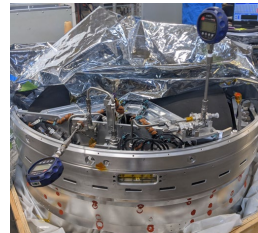
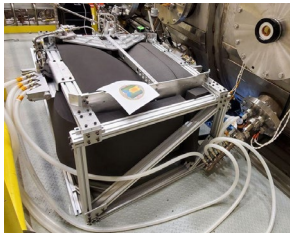
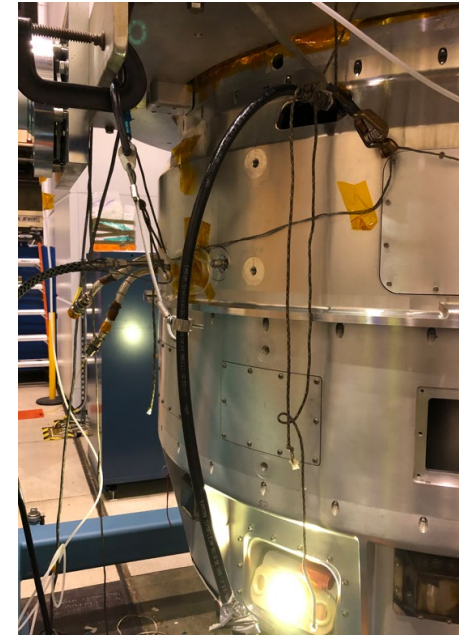
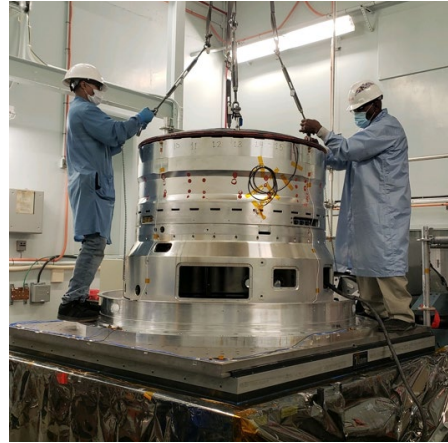
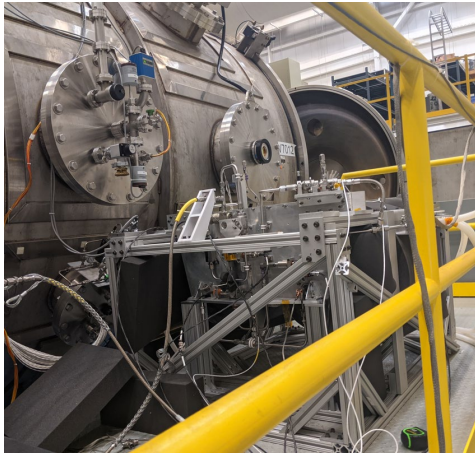

Test Campaign, Phase II

Subsystem Level: Inflatable Volume Tori Simulator (IVTS) Test



Test Campaign, Phase III

System Level Testing: CST, RV Level Vibe

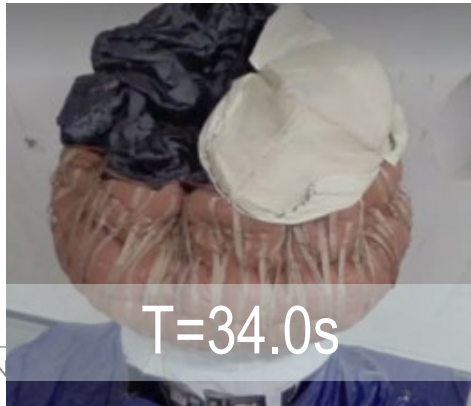
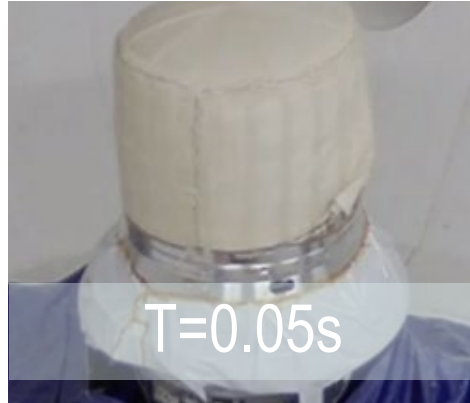
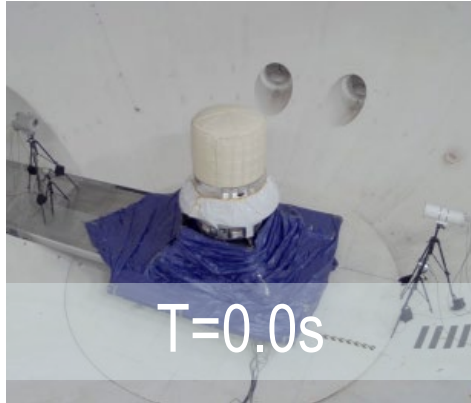

Inflation System Flight Performance

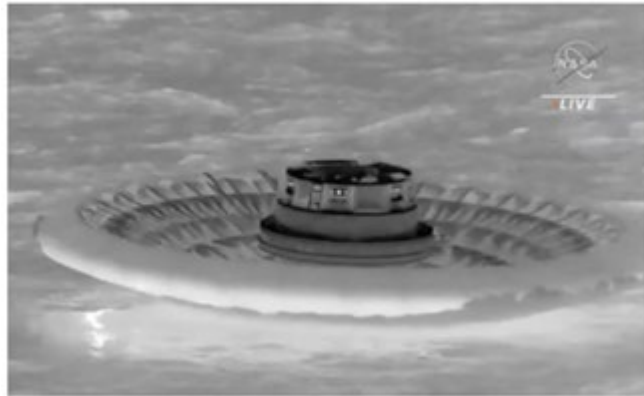
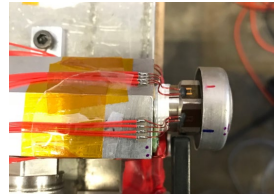

Hot Film Anemometer Excitation, Component Level Testing

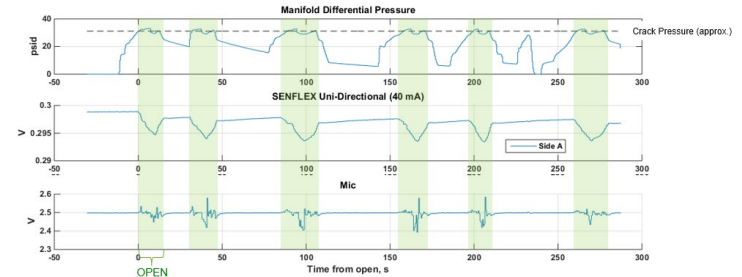

Hot Film Anemometer Excitation, Component Level Testing

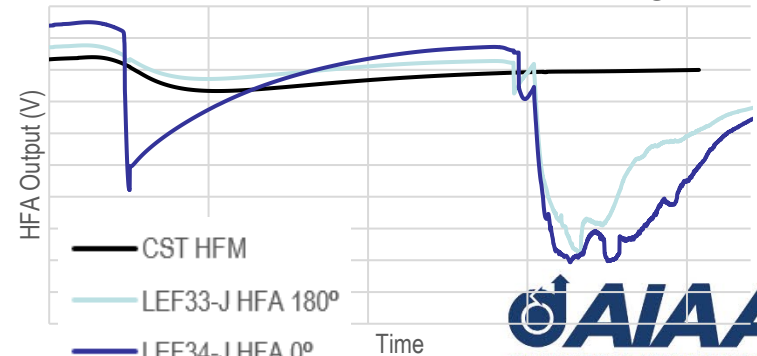

Test Campaign Summary Take Aways

- Extensive testing at the component level enables a flexible and adaptive system
- Greatest risks to an aggressive pneumatics campaign are the soft seals
- No test, or test results are inconsequential



Questions?



AMERICAN INSTITUTE OF
AERONAUTICS AND ASTRONAUTICS