

## Hybrid Thermally Efficient Core Project

### Challenge

- The Hybrid Thermally Efficient Core (HyTEC) Project will accelerate the development of the next generation small-core turbofan through improvements in efficiency, durability, performance, hybridization, and sustainability to meet the next Entry into Service (EIS) single aisle aircraft expected in the 2030s.
- HyTEC directly benefits the Sustainable Flight National Partnership and US Aviation net zero carbon emissions goals.

### Expected Impacts

New technology advancements to enable small core, more efficient turbine engines:

- 5-10% fuel burn reduction versus 2020 best in class
- Up to 20% power extraction (4 times current state of the art) at altitude to optimize propulsion system performance and enable hybridization
- Efficient operability of high blend (>80%) Sustainable Aviation Fuels (SAFs) in 2030s EIS combustors.

### Solution

- Develop of suite of technologies to Technical Readiness Level 6 (TRL 6) that can be integrated into next generation engines in the 2030s.
- Generate System Analysis and Integration (SA&I) models to assess HyTEC advancements against performance metrics.

### Phase 1: Component TRL Development

HyTEC, along with domestic partners, is currently developing technologies (up to TRL 4-5) such as advanced materials, aerodynamic improvements, and electric power extraction/insertion. (2021-2025)

- Ceramic Matrix Composites (CMC)
- Environmental Barrier Coatings (EBC)
- High Pressure Turbines
- High Pressure Compressors
- Power Extraction Technologies
- Sustainable Aviation Fuels

### Phase 2: Core Demonstration

HyTEC will integrate component technologies from Phase 1 into an engine core demonstration for Phase 2 (2024-2028). This capstone test will prove the benefits of the technologies and be the basis for new engine products in the 2030s.

### Partners

- GE Aerospace - Phase 1 & 2
- Raytheon Pratt and Whitney - Phase 1
- University of Notre Dame
- Penn State University

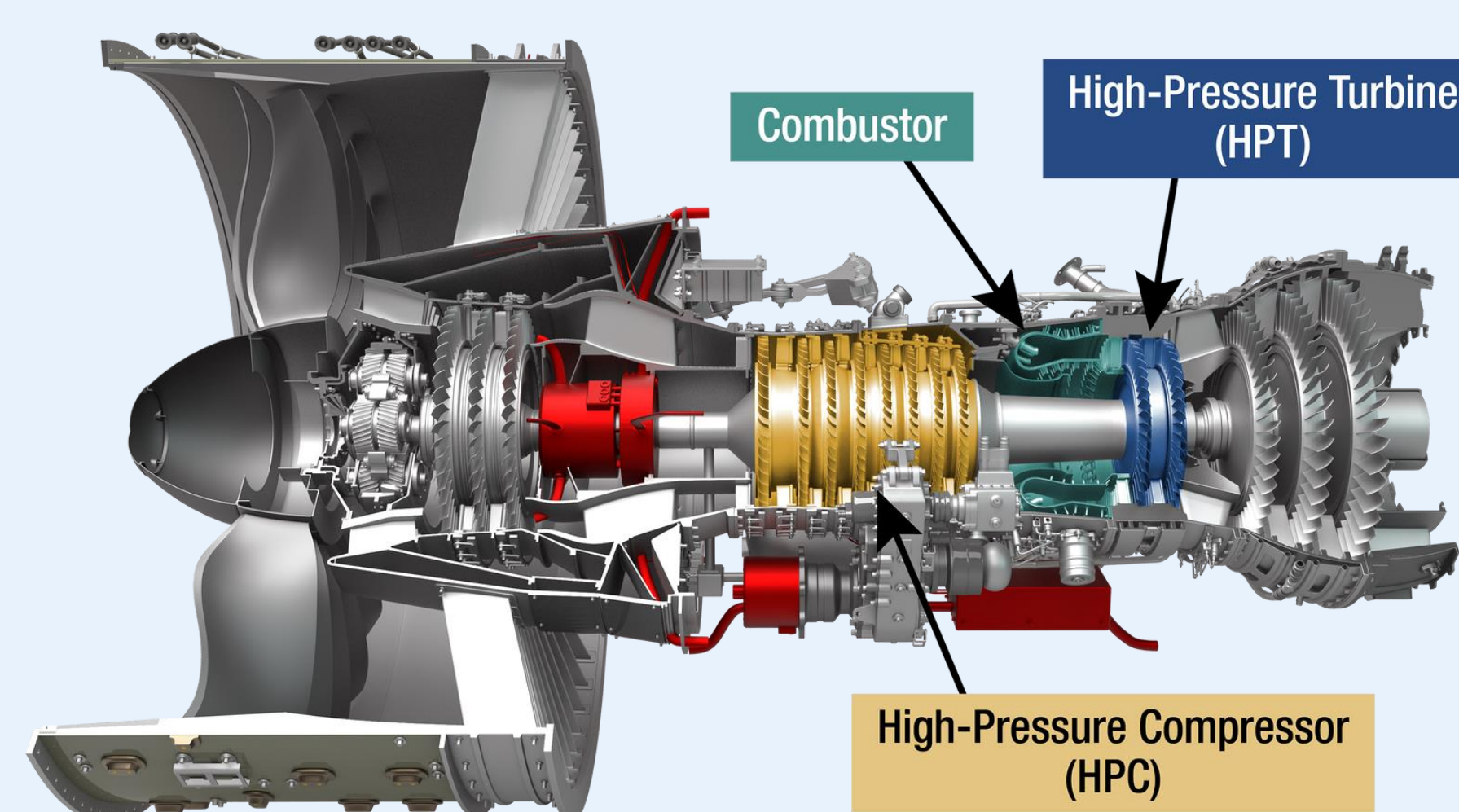

HyTEC Technology Areas

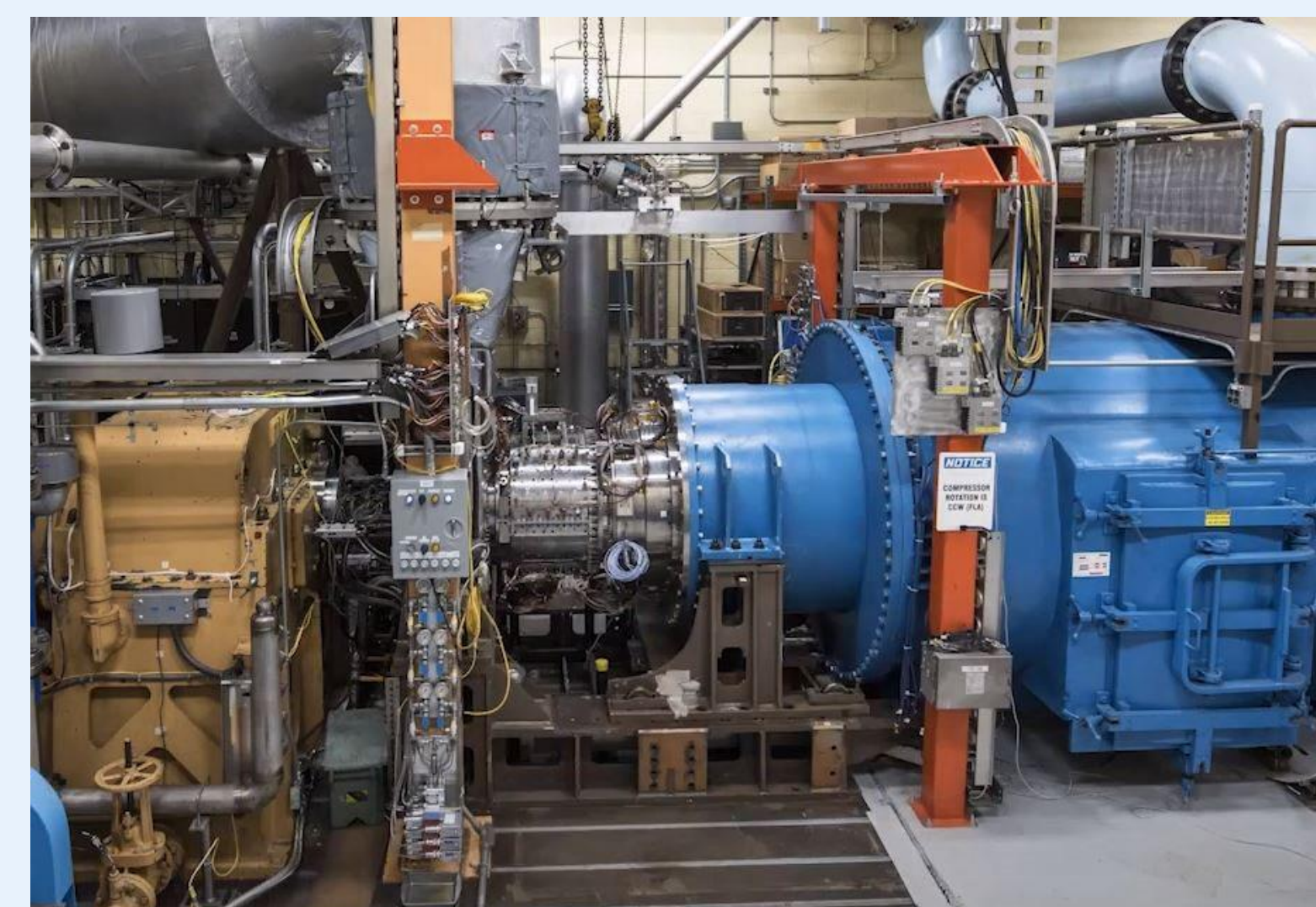

Compressor Test Facility at NASA

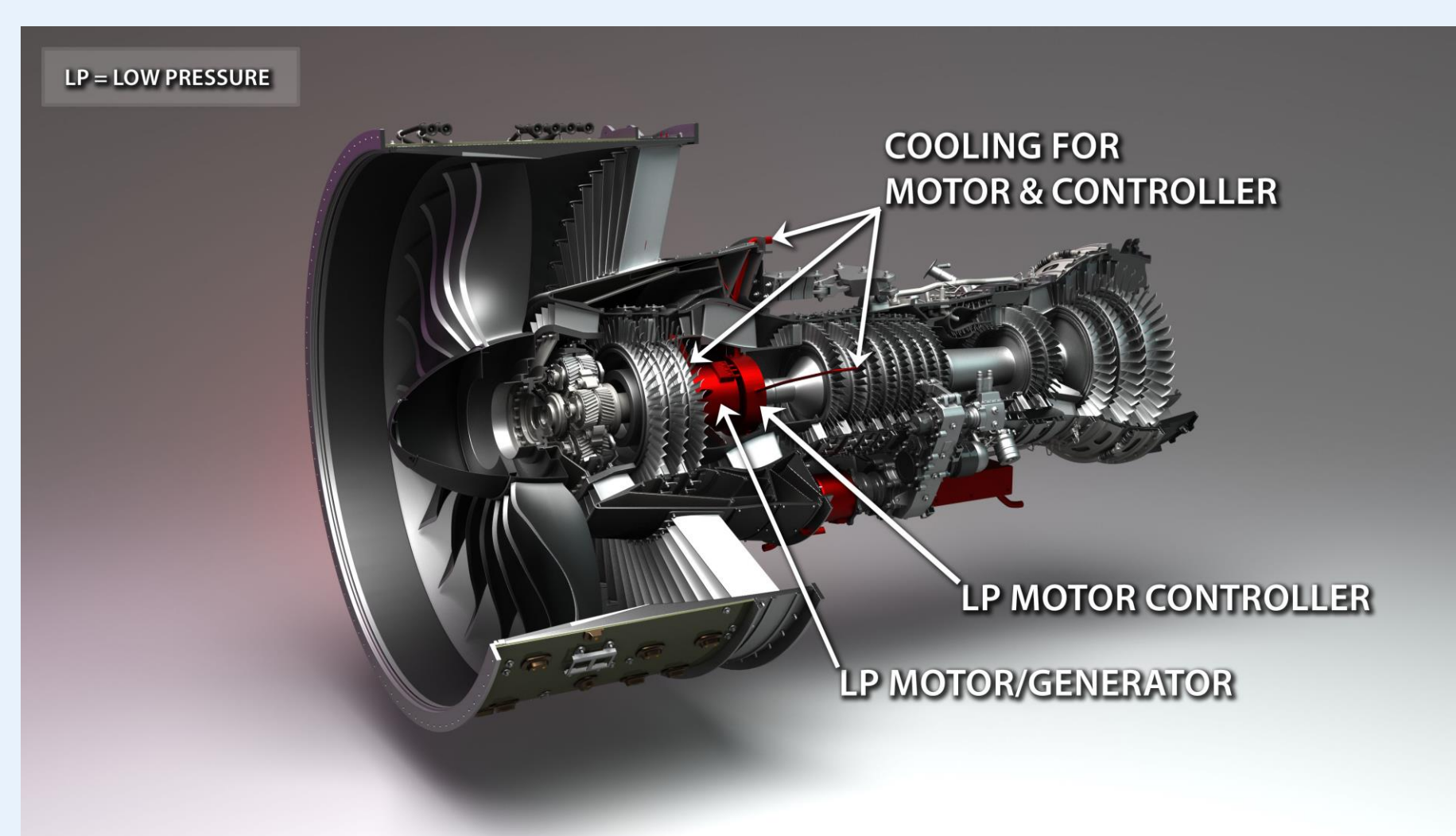

Power Extraction Components



High Temperature Material Testing at NASA