

Transformational Tools and Technologies (T³) Project

Material Data Management – State of the Art and Recent Developments

Steve Arnold
NASA Glenn Research Center

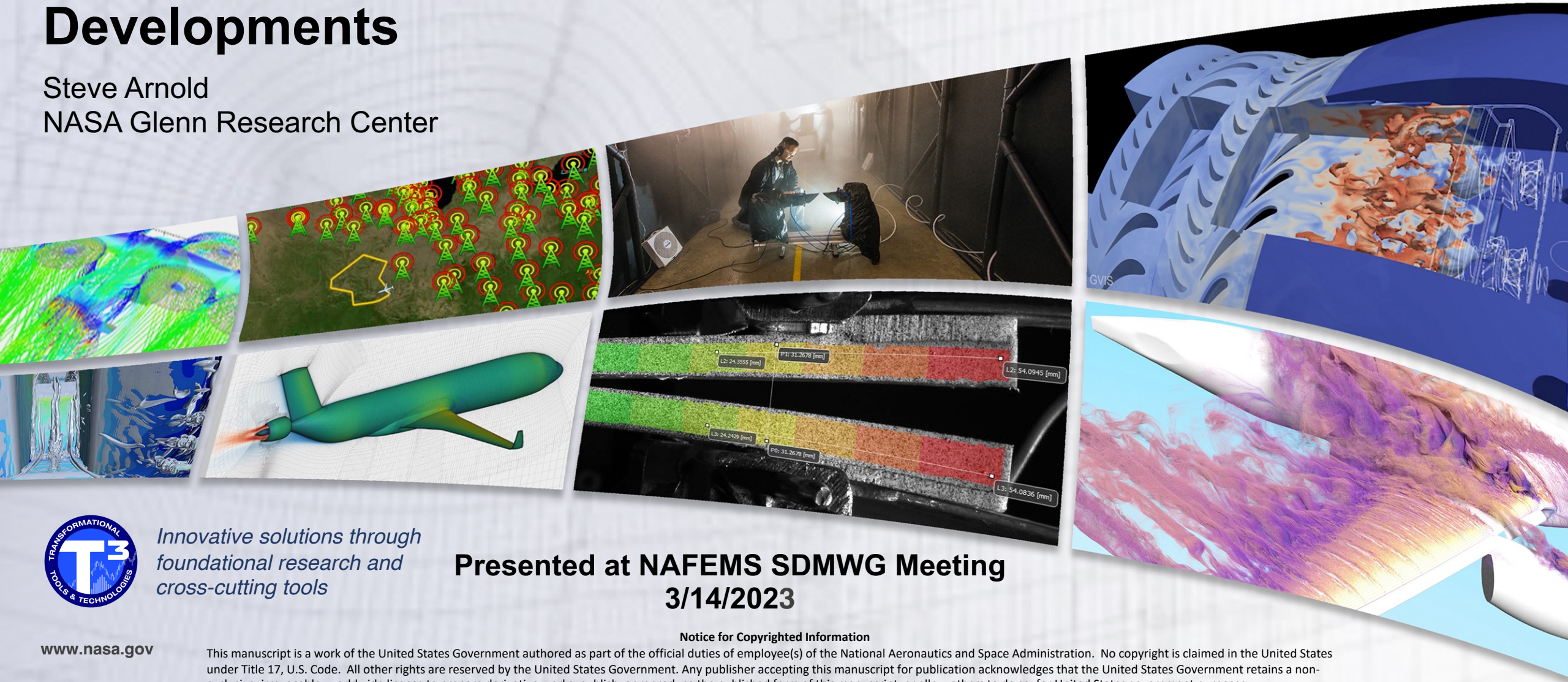

*Innovative solutions through
foundational research and
cross-cutting tools*

**Presented at NAFEMS SDMWG Meeting
3/14/2023**

Notice for Copyrighted Information

This manuscript is a work of the United States Government authored as part of the official duties of employee(s) of the National Aeronautics and Space Administration. No copyright is claimed in the United States under Title 17, U.S. Code. All other rights are reserved by the United States Government. Any publisher accepting this manuscript for publication acknowledges that the United States Government retains a non-exclusive, irrevocable, worldwide license to prepare derivative works, publish, or reproduce the published form of this manuscript, or allow others to do so, for United States government purposes.

Historical Levels of Management

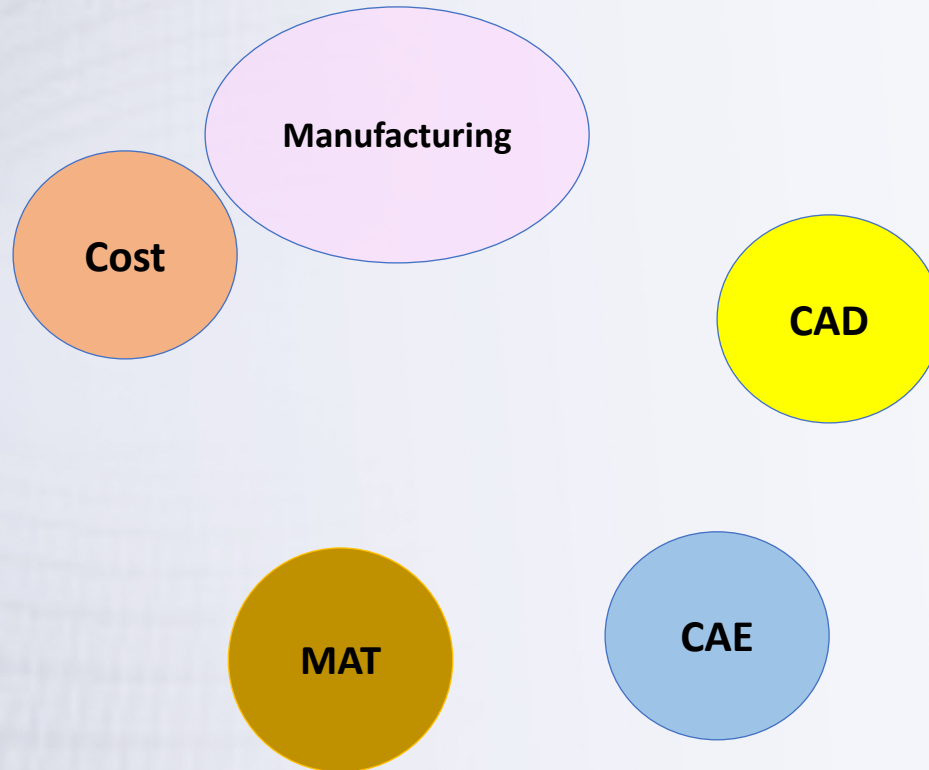

Data (MAT, CAE, CAD, Cost, etc.)

- Disparate groups of data
- Unmanaged
- No meta data
- Limited searchability
- Possibly duplicated
- Likely not the latest most accurate information

Database (Excel/Access NOT)

- A **database** is a collection of information that is organized so that it can easily be accessed, managed, and updated.
- In one view, **databases** can be classified according to types of content: bibliographic, full-text, numeric, and images

Historical Levels of Management

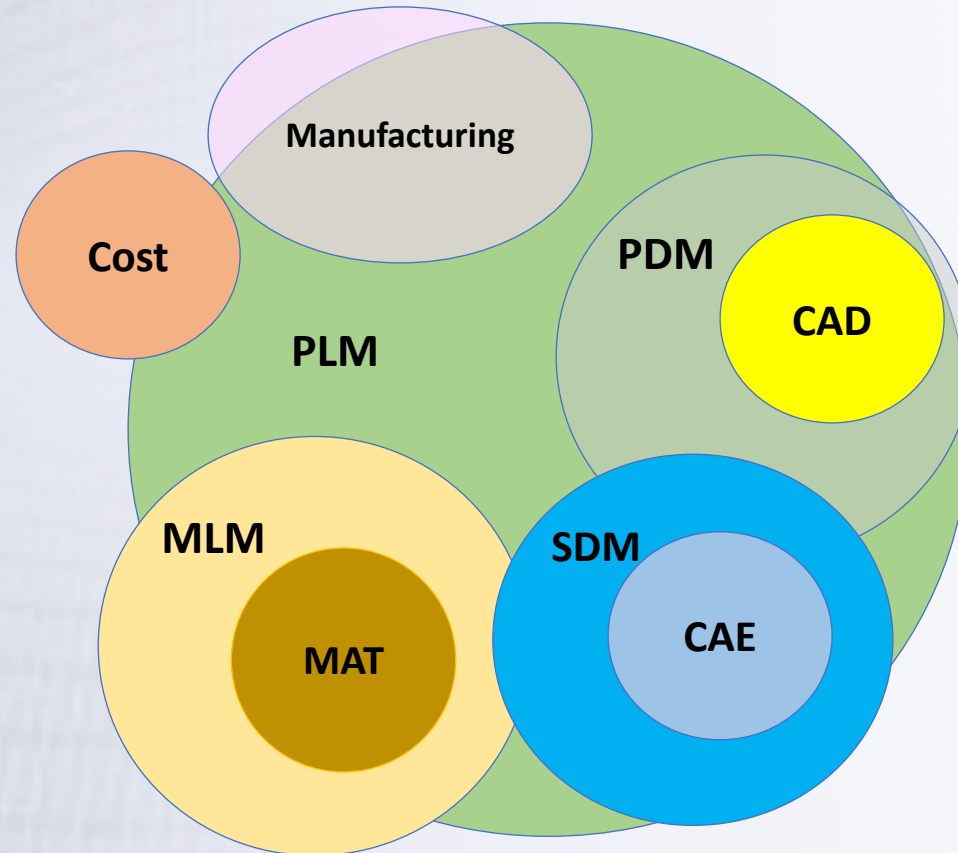

PDM – Product Data Management

Designed to manage **CAD** data

SDM – Simulation Data Management

Designed to manage **CAE** data

MLM – Material Lifecycle Management

Designed to manage **MAT** data

PLM – Product Lifecycle Management

Designed to manage and integrate engineering data and processes as well as business and manufacturing processes

- From cradle to grave

Historical Levels of Management

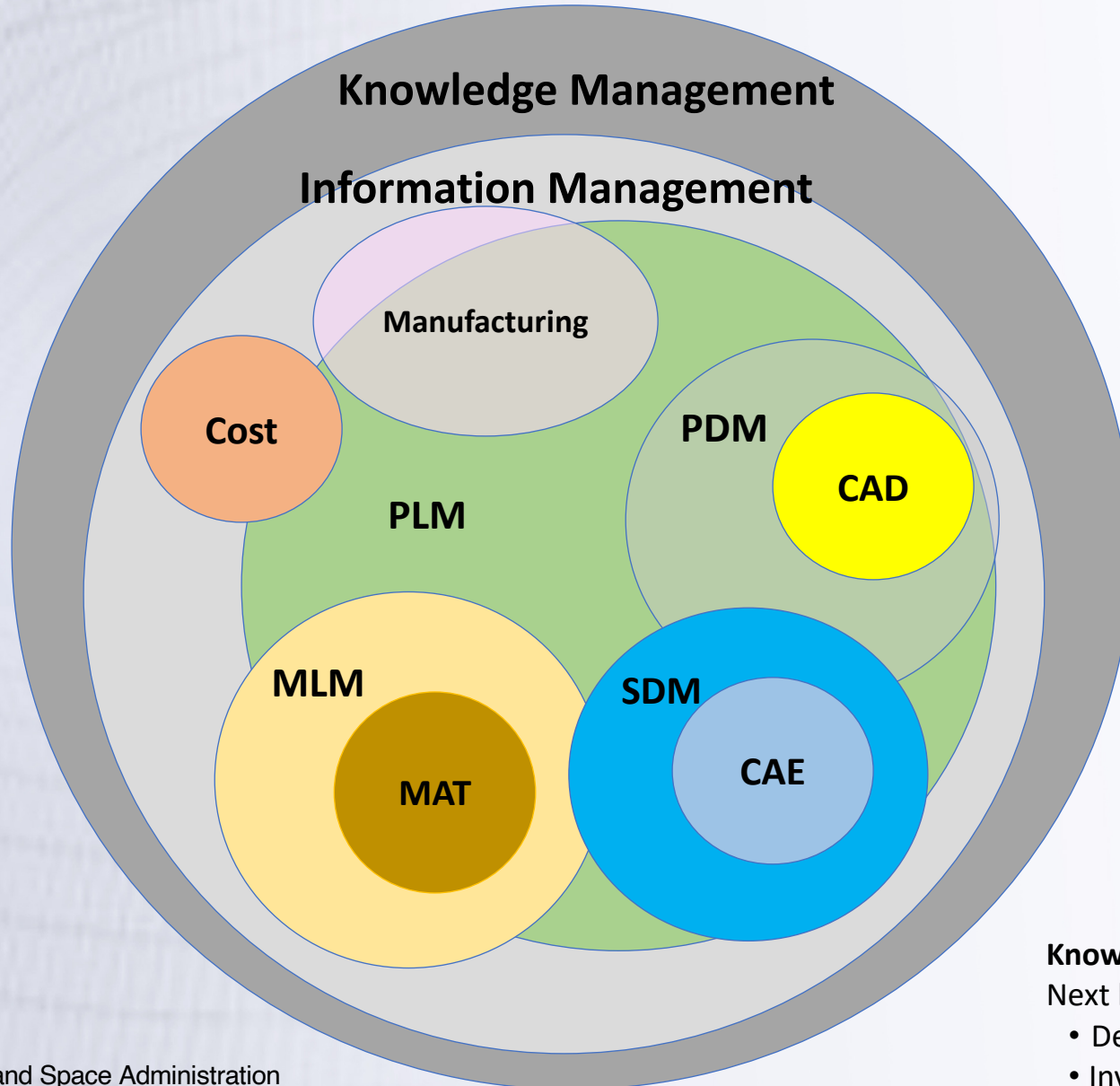

PDM – Product Data Management
Designed to manage **CAD** data

SDM – Simulation Data Management
Designed to manage **CAE** data

MLM – Material Lifecycle Management
Designed to manage **MAT** data

PLM – Product Lifecycle Management
Designed to manage and integrate engineering data and processes as well as business and manufacturing processes

- From cradle to grave

Information Management

- Current SOA
- Deals with explicit data & information,
- Technology and “Know what”

Knowledge Management

- Next level of management required to fully realize 2040 Vision
- Deals with tacit information; People; “Know how”
 - Involves entire supply-chain
 - Researcher to Designer to Regulatory Bodies









Vision 2040: A Roadmap for Integrated, Multiscale Modeling and Simulation of Materials and Systems



- Top performing organizations rate **New Materials** as one of **THE MOST IMPORTANT** factors in meeting their innovation goals (Historically new materials ≥ 20 years)



Nine Identified Key Element Discipline Areas

- | | |
|--|---|
|  1. Models and Methodologies |  6. Data, Informatics, & Visualization |
|  2. Multiscale Measurement & Characterization Tools and Methods |  7. Workflows & Collaboration Frameworks |
|  3. Optimization & Optimization Methodologies |  8. Education & Training |
|  4. Decision Making and UQ |  9. Computational Infrastructure |
|  5. Verification & Validation | |

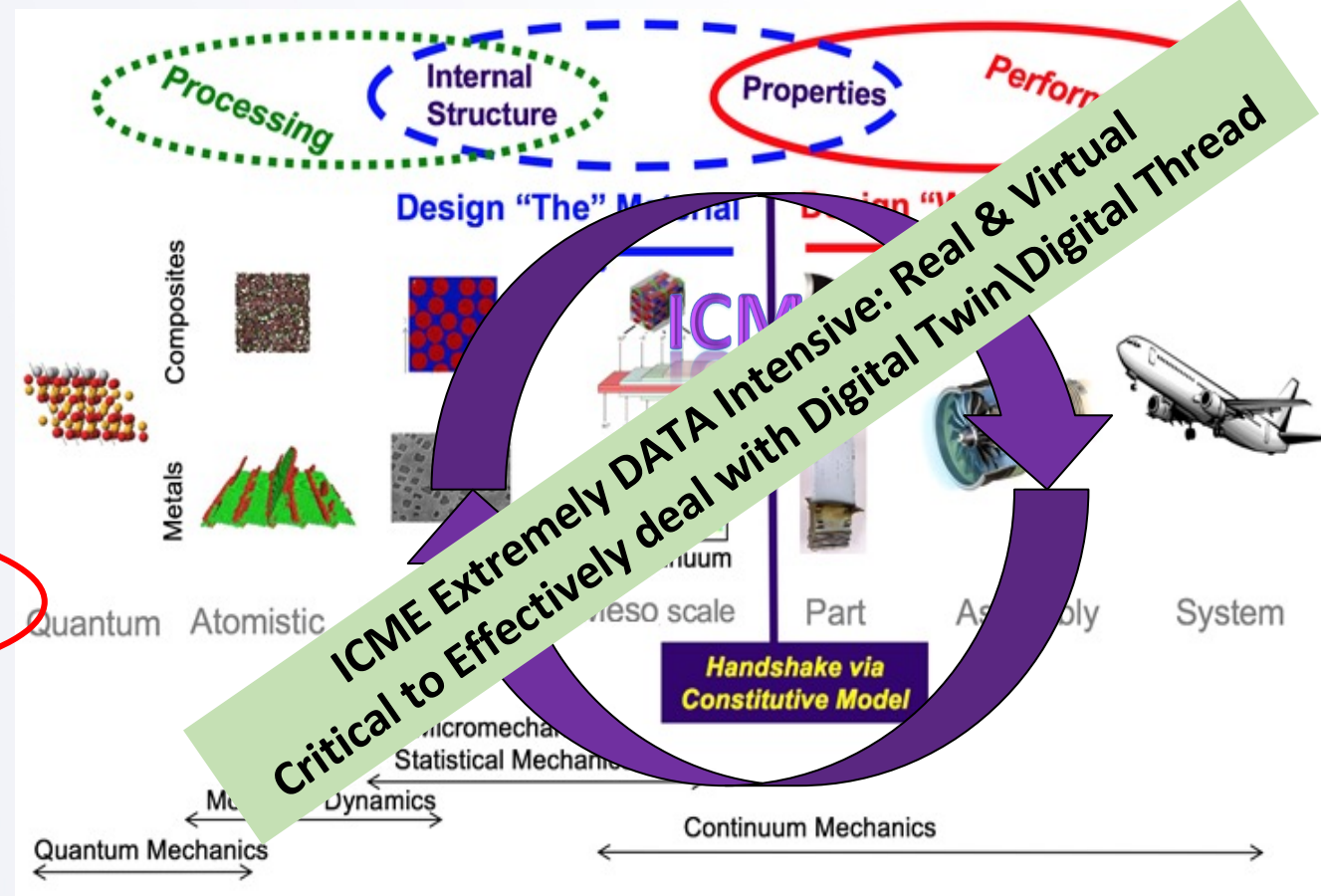

Requires a robust information management system

Virtual Testing Can Enable Significant Cost Savings in Certification Process



Experimental Building Block Approach

Model Building Block Approach

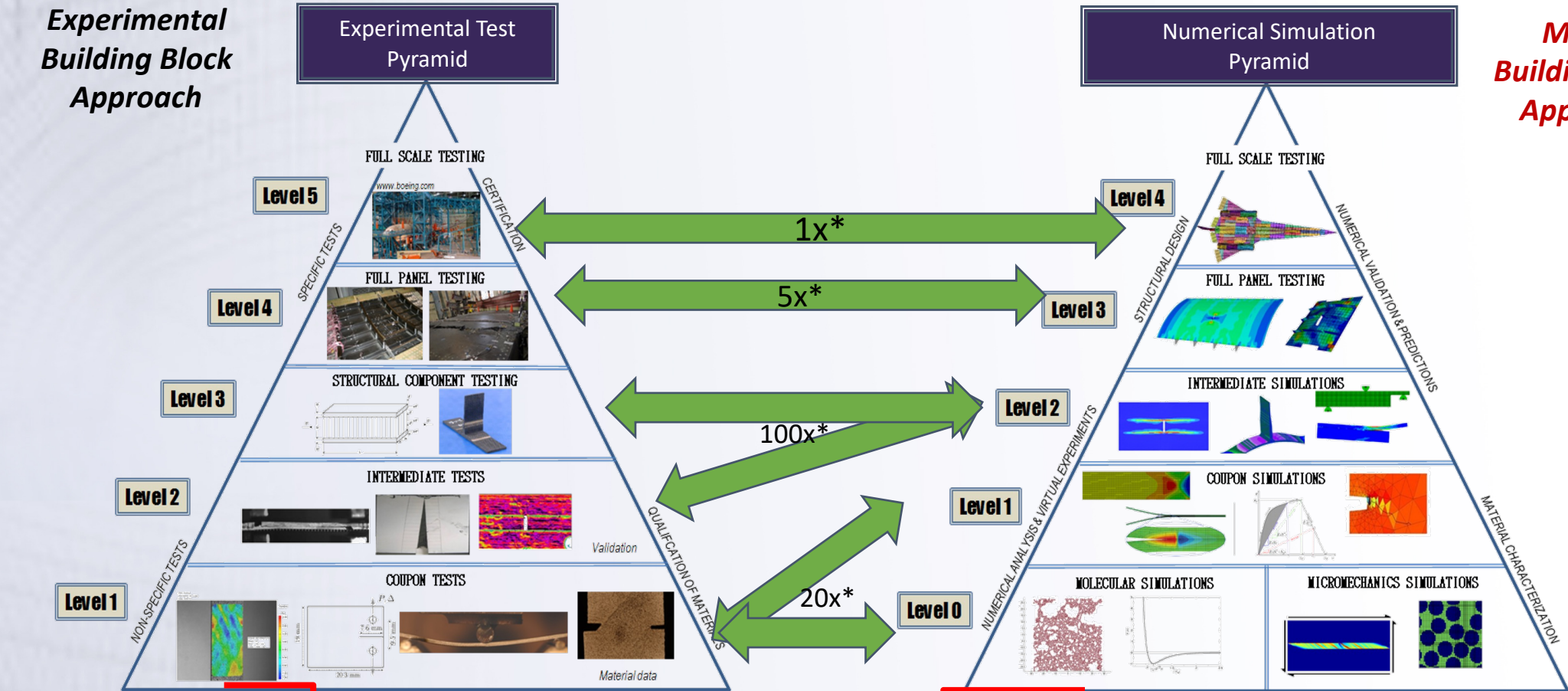

* OEM information

Requires Information Management

\$\$\$ Savings!

A robust **validated computational** platform is **essential** for sustainable, cost-effective technology development program
 ➤ **reduced testing and time to certify!**



Why Does Material Information Management Matter?

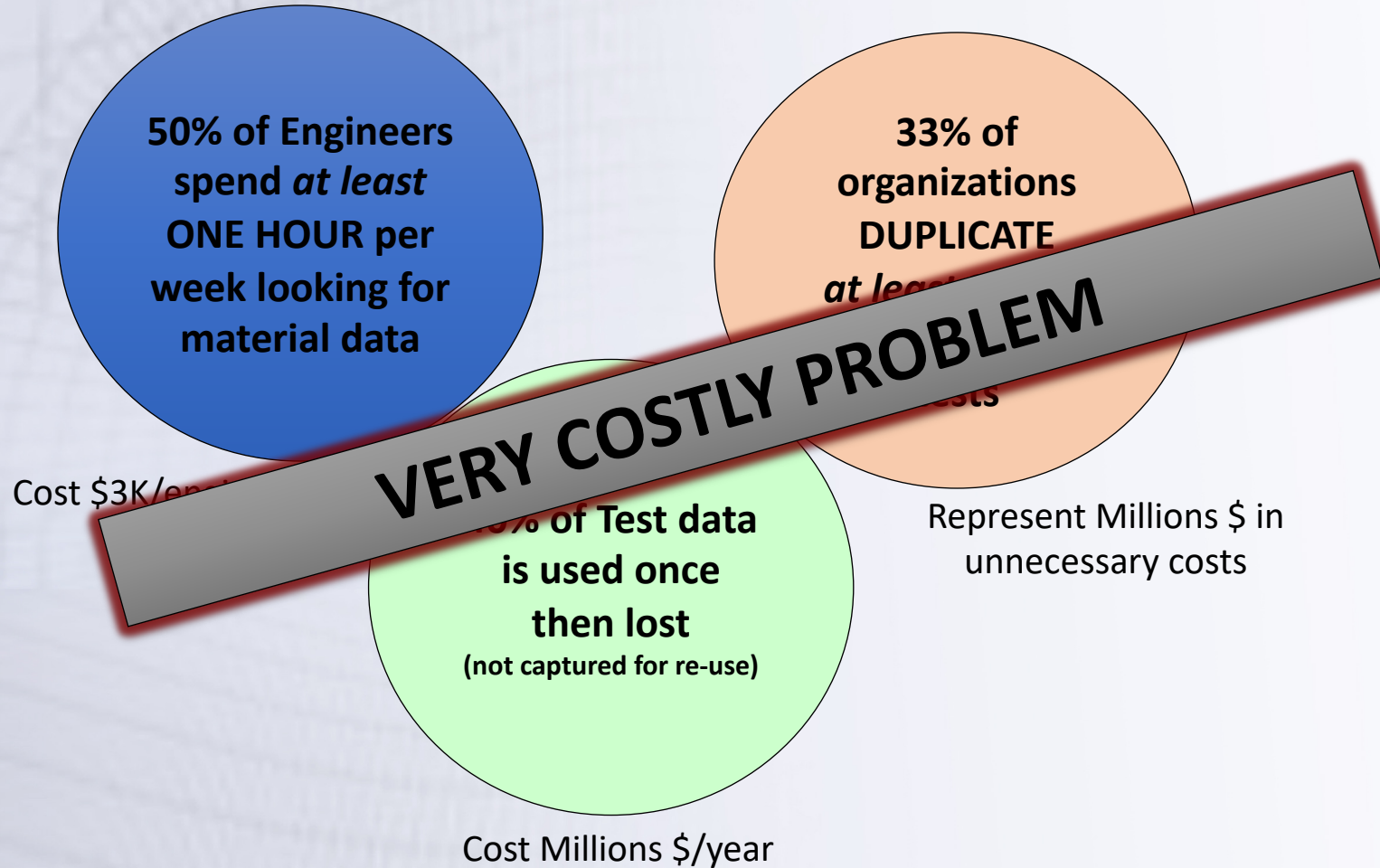

David Meza: Head of Knowledge Management at NASA, JSC
Status Quo of Collaboration

- “Most engineers have to look at 13 different sources to find the information they are looking for”
- “46% of workers can’t find the information about half the time”
- “30% of total R&D funds are spent to redo what we’ve already done once before”
- “54% of our decisions are made with inconsistent or incomplete, or inadequate information”

<https://www.youtube.com/watch?v=QEBVoultYJg>

Axel Reichwein, June 5, 2018



Data from July 2012 survey of 350 Granta customers/contacts; 35% N America, 45% Europe, 20% elsewhere; 25% current customers, 75% not customers

MDMC* Organizations Stated Return on Investment (ROI)



Arguments (Worth \$Millions)

Establishing the case for change		Establishing the value of change	
Problems	Implications	Needs	Value or Payoff
<p>We lose vital materials information (e.g., property data)</p>	<p>→</p> <ul style="list-style-type: none"> • Must recreate it • Slow down design cycle • Potential of using uncontrolled information • Appear Unprofessional • Wasted investment (time and money) • Need for redesign • Negative impact on morale 	<p>↔</p> <p>A simple, reliable and easy to use way to store my materials information (e. g., property data)</p>	<p>→</p> <ul style="list-style-type: none"> • Reduce cost/waste • Accelerate design cycle • Increase Confidence from Customers (internal and external) • Potential for better/more innovation • Decrease time to market
<p>I waste a lot of time finding materials data</p>	<p>→</p> <ul style="list-style-type: none"> • Inefficient use of time • Waste of money • Miss deadline(s) • Slow Design process • Longer Time to market (Brand image, Customers, Competitive advantage...) 	<p>↔</p> <p>A simple, reliable and easy to use way to find my materials property data in a format I need</p>	<p>→</p> <ul style="list-style-type: none"> • Save time and money • Decrease time to market • Accelerate Design process • Increase efficiency • Optimize engineering time • Faster Product derivative creation
<p>Problems/issues arise because we use incorrect, inconsistent, or obsolete information/data (e.g., potentially wrong material)</p>	<p>→</p> <ul style="list-style-type: none"> • Design and lifing rework • Potential conservative/nonconservative design • In-service failure • Product recalls • Damage to brand image • Loss of internal confidence - lack of buy-in from data customers • Have difficulty getting ISO certification 	<p>↔</p> <p>A simple, reliable, easy to use and error-free way to process, organize and deploy/control my data</p> <p>→</p> <p>Improve relationship between materials authority and downstream users - buy-in from customers</p>	<p>→</p> <ul style="list-style-type: none"> • Reduction of rework • Avoid failures • Competitive (efficiently designed) products • Reduce non-recurring engineering costs • Improve productivity • Help pass ISO certification • Customer confidence • Avoid brand damage through bad publicity • Reduce risk

*MDMC is a Consortium of Government and Industrial partners who are interested in developing the required software systems/tools and best practices for material information management in the aerospace and defense industries

MDMC* Organizations Stated Return on Investment (ROI)



Arguments (Worth \$Millions)

Establishing the case for change		Establishing the value of change	
Problems	Implications	Needs	Value or Payoff
<p>We lose vital materials information (e.g., property data)</p>	<p>→</p> <ul style="list-style-type: none"> • Must recreate it • Slow down design cycle • Potential of using uncontrolled information • Appear Unprofessional • Wasted investment (time and money) • Need for redesign • Negative impact on morale 	<p>↔</p> <p>A simple, reliable and easy to use way to store my materials information (e. g., property data)</p>	<p>→</p> <ul style="list-style-type: none"> • Reduce cost/waste • Accelerate design cycle • Increase Confidence from Customers (internal and external) • Potential for better/more innovation • Decrease time to market
<p>I waste a lot of time finding materials data</p>	<p>→</p> <ul style="list-style-type: none"> • Inefficient use of time • Waste of money • Miss deadline(s) • Slow Design process • Longer Time to market (Brand image, Customers, Competitive advantage...) 	<p>↔</p> <p>A simple, reliable and easy to use way to find my materials property data in a format I need</p>	<p>→</p> <ul style="list-style-type: none"> • Save time and money • Decrease time to market • Accelerate Design process • Increase efficiency • Optimize engineering time • Faster Product derivative creation
<p>Problems/issues arise because we use incorrect, inconsistent, or obsolete information/data (e.g., potentially wrong material)</p>	<p>→</p> <ul style="list-style-type: none"> • Design and lifing rework • Potential conservative/nonconservative design • In-service failure • Product recalls • Damage to brand image • Loss of internal confidence - lack of buy-in from data customers • Have difficulty getting ISO certification 	<p>↔</p> <p>A simple, reliable, easy to use and error-free way to process, organize and deploy/control my data</p> <p>→</p> <p>Improve relationship between materials authority and downstream users - buy-in from customers</p>	<p>→</p> <ul style="list-style-type: none"> • Reduction of rework • Avoid failures • Competitive (efficiently designed) products • Reduce non-recurring engineering costs • Improve productivity • Help pass ISO certification • Customer confidence • Avoid brand damage through bad publicity • Reduce risk

MDMC* Organizations Stated Return on Investment (ROI)



Arguments (Worth \$Millions)

Establishing the case for change		Establishing the value of change	
Problems	Implications	Needs	Value or Payoff
<p>We lose vital materials information (e.g., property data)</p>	<ul style="list-style-type: none"> • Must recreate it • Slow down design cycle • Potential of using information • Appear Unprofessional • Wasted investment (time and money) • Need for redesign • Negative impact on morale 	<p>GRC Goal: ZERO (Minimal) LOSS of DATA</p> <p>use way to store my materials information (e. g., property data)</p>	<ul style="list-style-type: none"> • Reduce cost/waste • Accelerate design cycle • Increase Confidence from Customers (internal and external) • Potential for better/more innovation • Decrease time to market
<p>I waste a lot of time finding materials data</p>	<ul style="list-style-type: none"> • Inefficient use of time • Waste of money • Miss deadlines • Slow Design • Longer Time to market (Brand image, Customers, Competitive advantage...) 	<p>GRC Goal: More Efficient Interaction between experimentalist and modelers</p>	<ul style="list-style-type: none"> • Save time and money • Shorten time to market • Increase Design process efficiency • Optimize engineering time • Faster Product derivative creation
<p>Problems/issues arise because we use incorrect, inconsistent, or obsolete information/data (e.g., potentially wrong material)</p>	<ul style="list-style-type: none"> • Design and lifting rework • Potential conservative/nonconservative design • In-service failure • Product recalls • Damage to brand image • Loss of internal confidence - lack of buy-in from data customers • Have difficulty getting ISO certification 	<p>GRC Goal: Excellence in Research</p> <p>A simple, reliable, easy to use and error-free way to process.</p> <p>Improve relationship between materials authority and downstream users - buy-in from customers</p>	<ul style="list-style-type: none"> • Reduction of rework • Avoid failures • Competitive (efficiently designed) products • Reduce non-recurring engineering costs • Improve productivity • Help pass ISO certification • Customer confidence • Avoid brand damage through bad publicity • Reduce risk

*MDMC is a Consortium of Government and Industrial partners who are interested in developing the required software systems/tools and best practices for material information management in the aerospace and defense industries

MDMC Organizations Stated Return on Investment (ROI) Arguments (Worth \$Millions)



Establishing the case for change		Establishing the value of change	
Problems	Implications	Needs	Value or Payoff
The access to my data is not secured enough or controlled	→ <ul style="list-style-type: none"> • Jail time • Data doesn't go into the system • Severe fines 	↔ <p>A simple, reliable, easy to use and error-free way to process, organize and deploy/control my data</p>	→ <ul style="list-style-type: none"> • Ticket to play • Business continuity
I can't comply with policy or regulations (e.g., ITAR)	→ <ul style="list-style-type: none"> • Jail or severe fines 	↔ <p>A simple, reliable, easy to use and error-free way to process, organize and deploy/control my data</p>	→ <ul style="list-style-type: none"> • Ticket to play • Business continuity
I don't have appropriate, secure access to mission-critical data throughout my organization.	→ <ul style="list-style-type: none"> • Don't know what data is available • Restricts ability to work effectively across organization • Reduced productivity • Too much effort to get the data you need - make something up! 	↔ <p>A simple, reliable, easy to use and error-free way to process, organize and deploy/control my data</p>	→ <ul style="list-style-type: none"> • Ability to perform assigned tasks





Motivation For Selection of Granta MI As Our Information Management/Collaboration Framework

**Quality
Integrity
Traceability**

**Right Data
Right Time
Right Format
Right Scale**

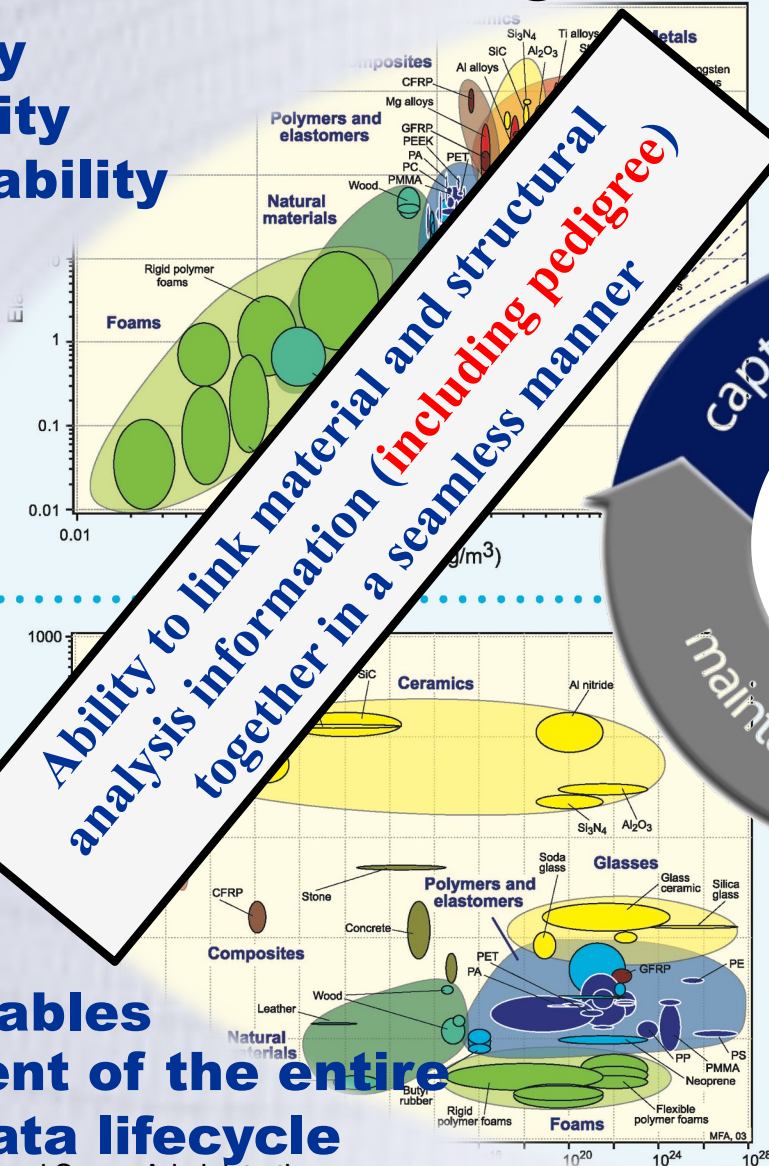

Ability to link material and structural analysis information (including pedigree) together in a seamless manner

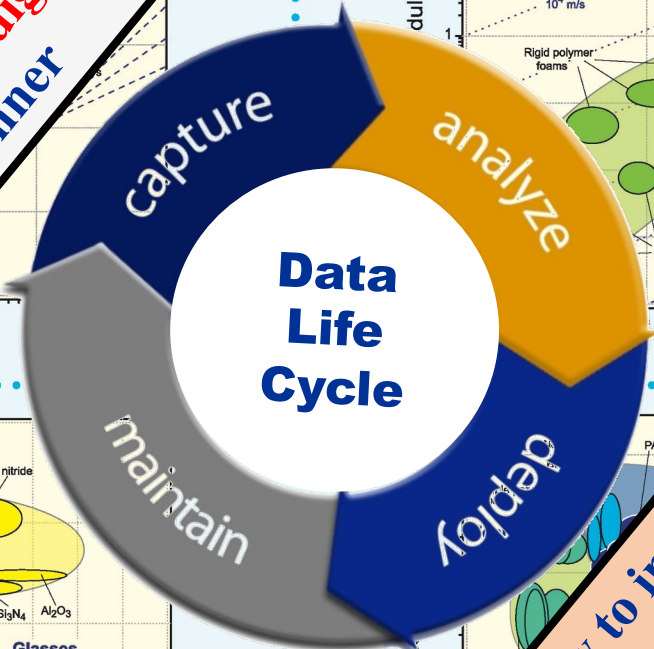

The ability to introduce best practices and preserve corporate knowledge from one generation to the next

Toolset enables management of the entire material data lifecycle

**Increased Efficiency
Competitiveness**

Information Management Essential For Fit-For-Purpose Material Design

OUTLINE



Established Data Schema for ICME that Enables Linkage of Test Data with Simulation Data at Different Length Scales:

- Required establishment of Material Pedigree, Manufacturing, Microstructure, Model Pedigree, and Software Tools Tables within Granta MI
- Digital Thread / Digital Twin
- Six key **accomplishments**

Additive Manufacturing
ICMAMS 2023, Aug 9, 2023

Py-MILab (ICMAMS 2023, Aug 9, 2023)
Data Analytics and Importer

Application Table
NASA TM-2022-00184033

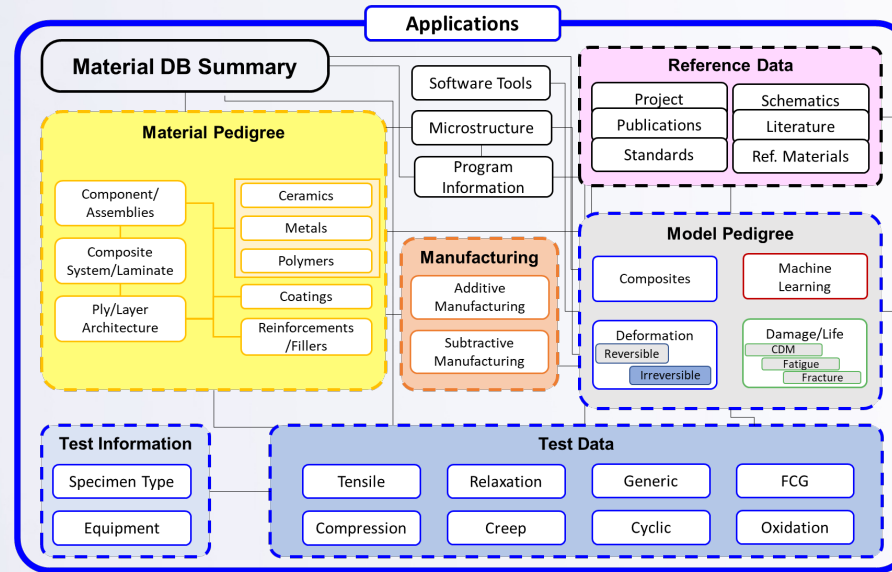

NASA GRC ICME Schema: Executive Summary
NASA TM-2023-0018337

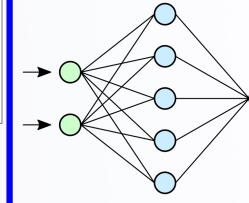

Machine Learning Table
NASA TM-2022-0017137

AIMAOS: Automated Information Management Across Organizations and Scales (TMS ICME, May 21, 2023)

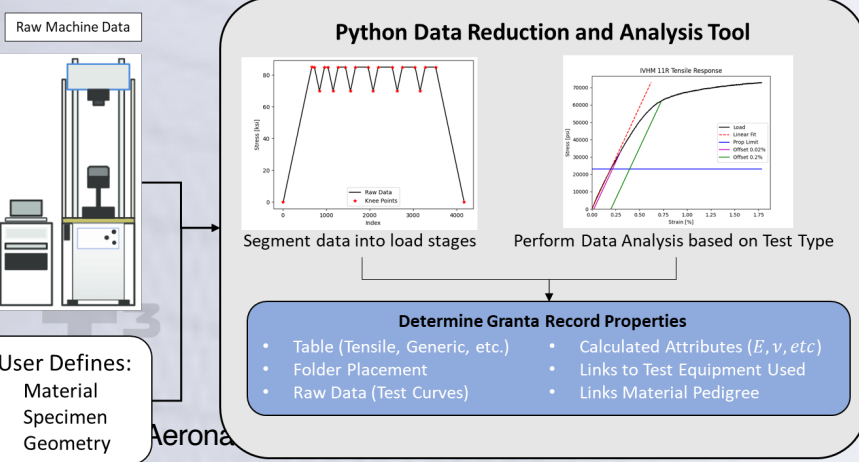
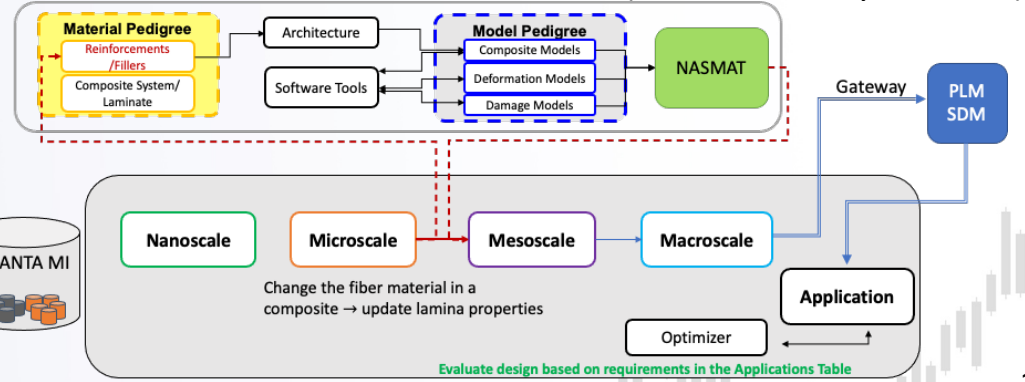

- Re-evaluate the requirements locally with periodic global (structural – PLM/SDM) updates

NASA GRC ICME Schema: An Executive Summary



- Recently published *NASA GRC ICME Schema: An Executive Summary* (NASA TM-2023-0018337)
 - To-date detailed summary on NASA GRC's philosophy for effective data management towards Vision 2040
 - Overview of database philosophy and best practices
 - Offers new users a starting point for effective materials data management
 - Overview of Granta MI (reference for new users)
 - Summary of each collection and table within the GRC Schema
 - Table purpose, linking behavior, tree structure, etc.
 - Summary of database tools developed at GRC

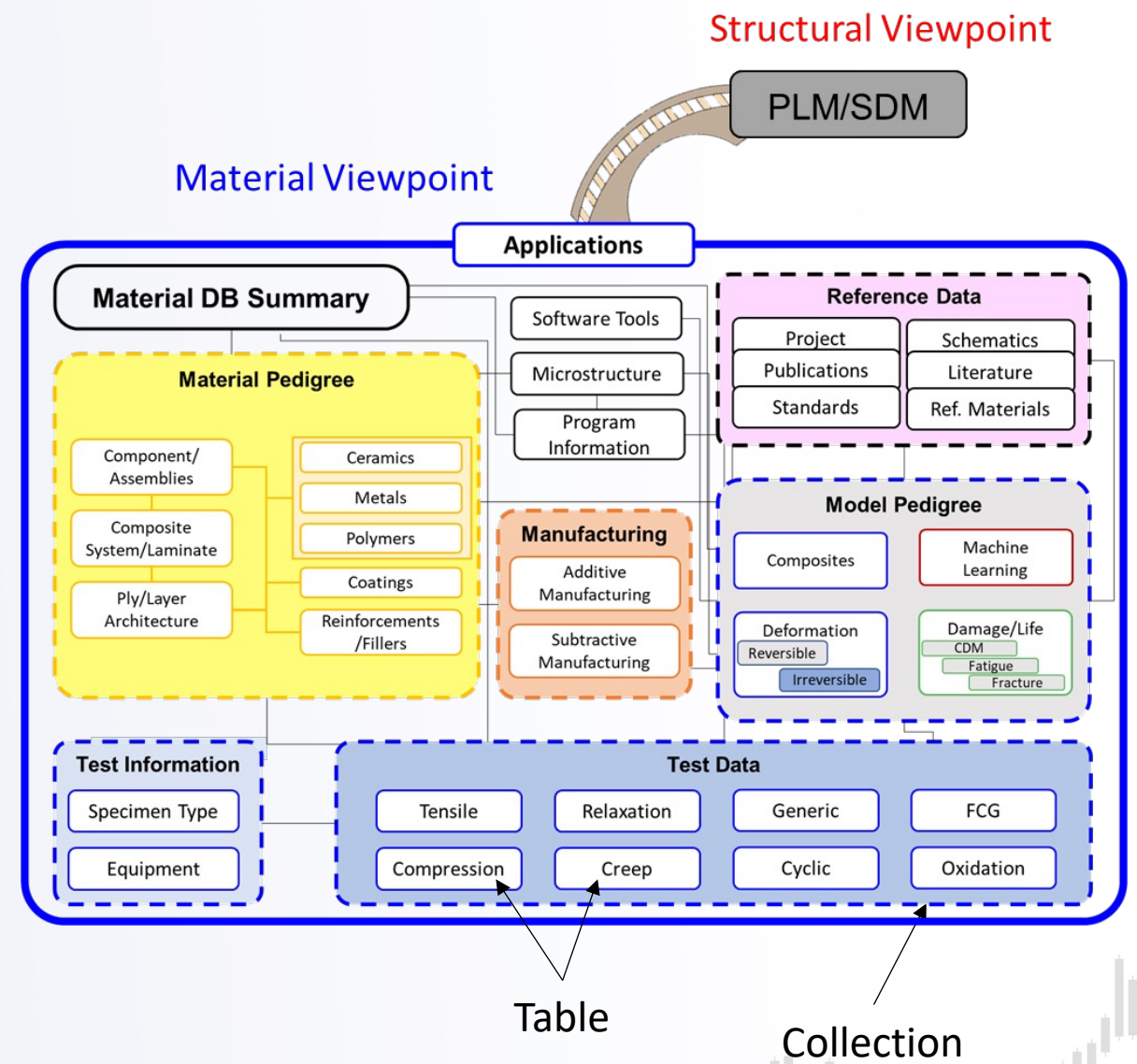

Integrated Workflow for Physics-Based Design and Analysis at Elevated Temperature



Cradle

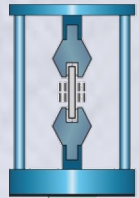

RAW TEST DATA

www.mdmc.net

ANSYS GRANTA MI

Traceable in-house relational materials database

TENSILE TEST DATA LOG

Test date: 04-12-2011
Operator: A. Grant
Test frame: DDC-41-17

Time (s)	Stress (ksi)	Strain (in./in.)
0.1	2.0	0.1
0.2	2.2	0.2
0.3	2.4	0.3
0.4	2.6	0.4
0.5	2.8	0.5
0.6	3.0	0.6
0.7	3.2	0.7
0.8	3.4	0.8
0.9	3.6	0.9

CALCULATE key parameters,
ANALYZE multiple files,
STORE original data

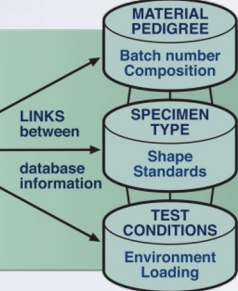
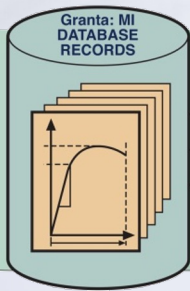

Mathematical Characterization Of Material Behavior

COMPARE

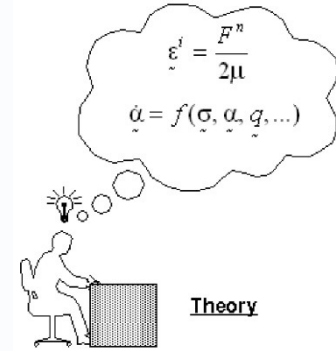

Automatically write required input information

Arm-Chair

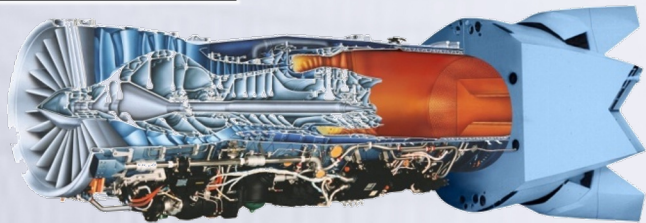

FE Analysis of components

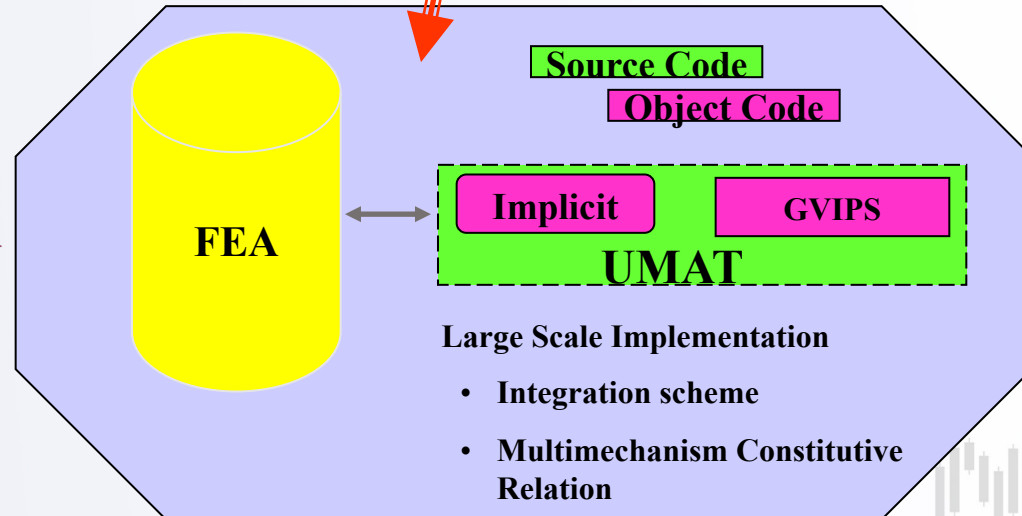

Structural Engineers Benefit From Linkage Between MLM and Engineering Application Software

Material Viewpoint ← → Structural Viewpoint

Manages lifecycle and information on all materials

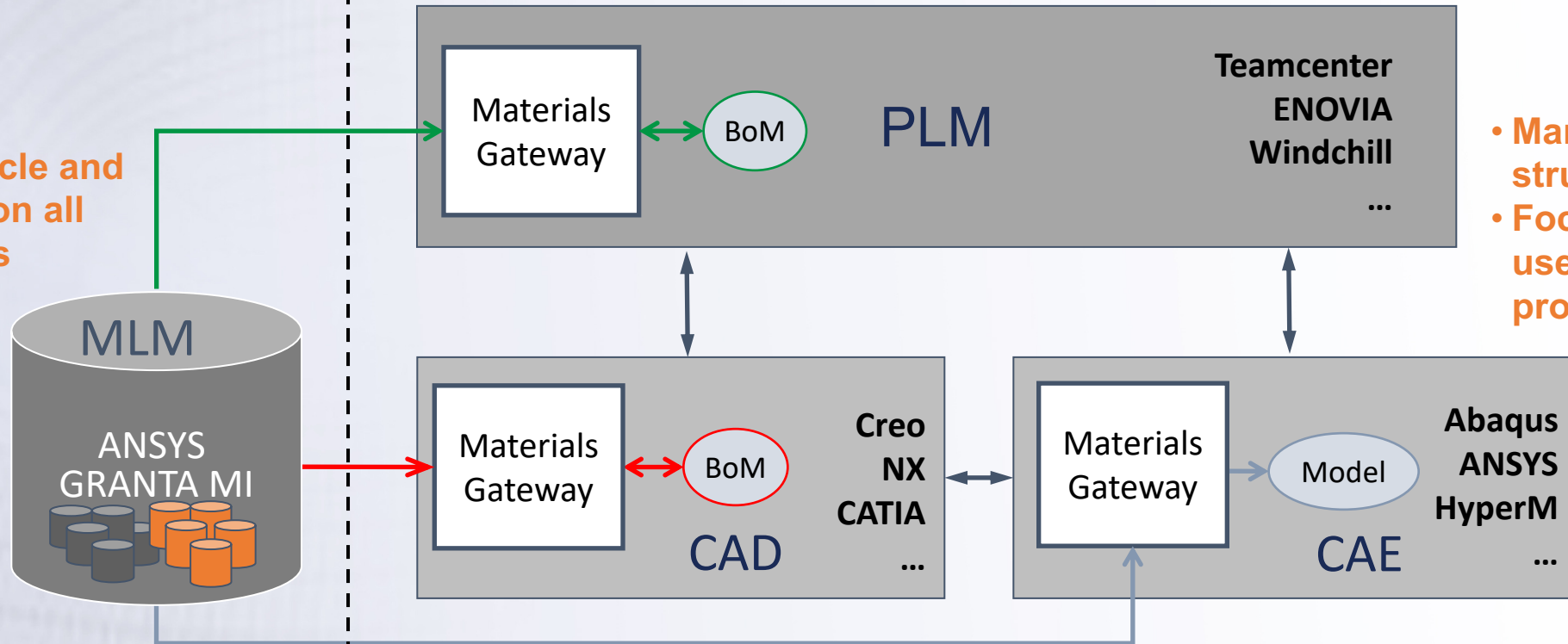

- Manages product structure and lifecycle
- Focus on materials used directly in products

This ensures that structural designers are using “gold standard” material properties that have been approved by organization

Information Management Essential For Fit-For-Purpose Material Design



OUTLINE

Application Table

NASA TM-2022-00184033

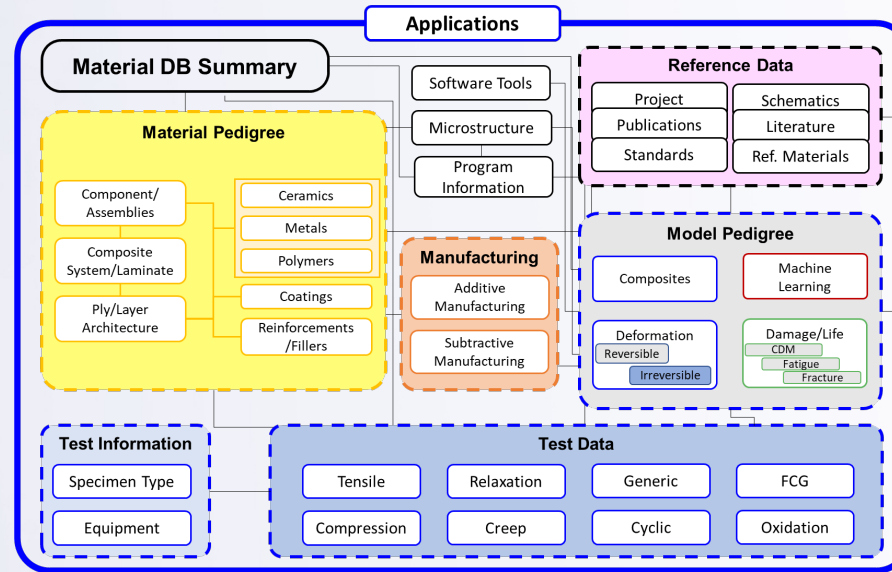

NASA GRC ICME Schema: Executive Summary

NASA TM-2023-0018337

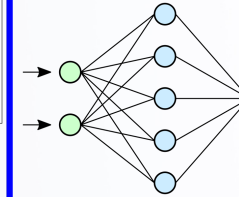

Machine Learning Table

NASA TM-2022-0017137

AIMAOS: Automated Information Management Across Organizations and Scales (TMS ICME, May 21, 2023)

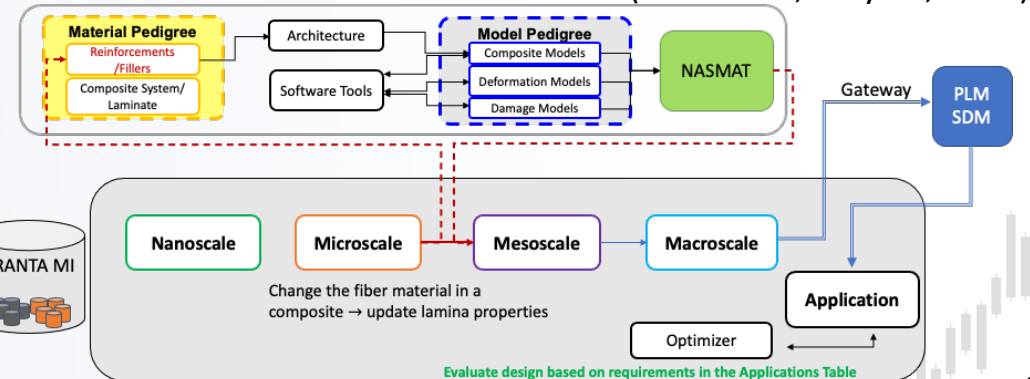

Established Data Schema for ICME that Enables Linkage of Test Data with Simulation Data at Different Length Scales:

- Required establishment of Material Pedigree, Manufacturing, Microstructure, Model Pedigree, and Software Tools Tables within Granta MI
- Digital Thread / Digital Twin
- Six key **accomplishments**

Additive Manufacturing
ICMAMS 2023, Aug 9, 2023

Py-MILab (ICMAMS 2023, Aug 9, 2023)
Data Analytics and Importer

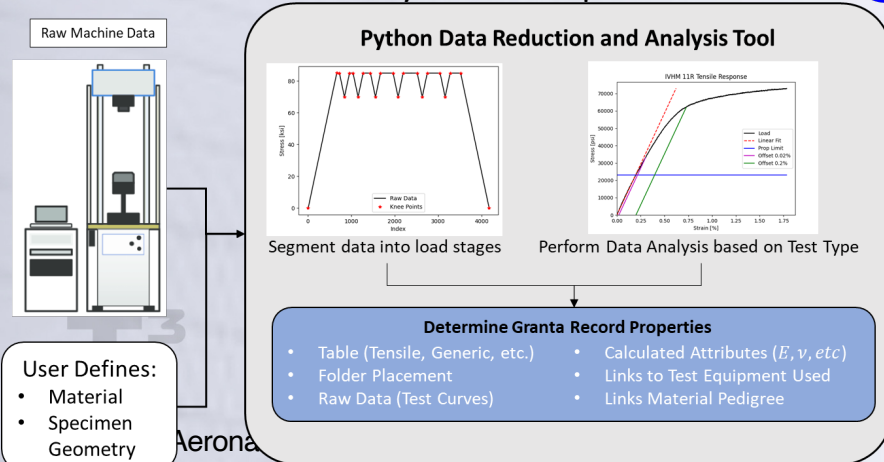

- Re-evaluate the requirements locally with periodic global (structural – PLM/SDM) updates

Machine Learning Is Critical For ICME



- Machine Learning plays a critical role in enabling ICME by providing speed and automation to materials discovery
- Developed image recognition algorithms to perform task automation such as micrograph segmentation
 - Reduces time to perform task and removes human bias
e.g., 190X EBC TGO; 22.5 hrs vs 7 min ; 1 measurement vs 7
- Create surrogate models for physics-based tools
 - Increase computational efficiency, enabling fast and accurate multiscale modeling
- **Data Management is critical for ML → must understand model's full pedigree so that it isn't misused**
 - Lose physics-based relationship between inputs and outputs when using a "black-box" surrogate
 - Incur *intellectual debt*

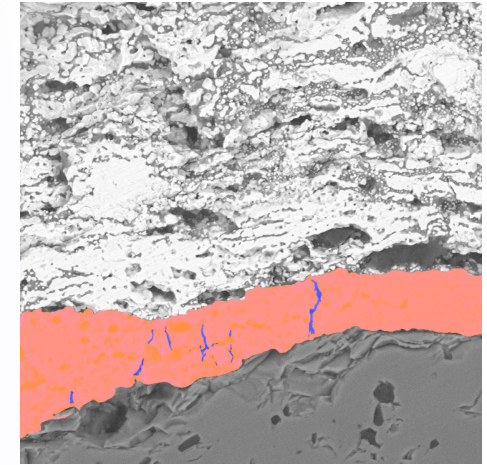
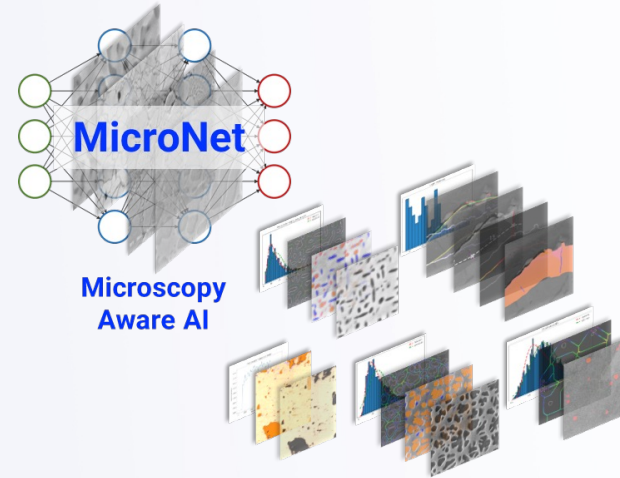

MicroNet: Automatic segmentation of micrographs

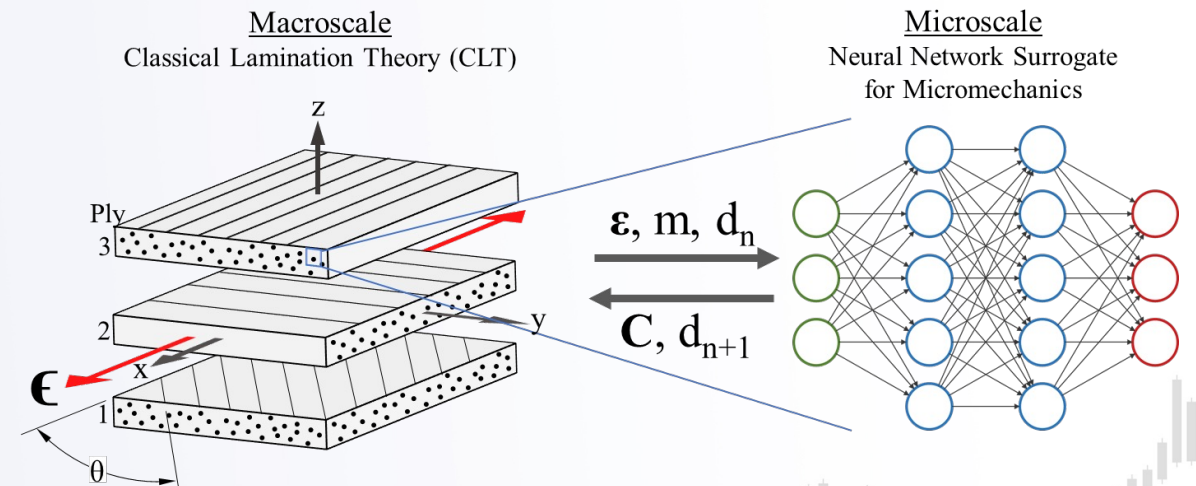

ML Surrogates for Physics-based Models



Effective Data Management for Machine Learning Data and Models



- Separate the data from the model in the NASA GRC ICME Schema

- Flexibility in model definition prevents data from being duplicated multiple places in the database

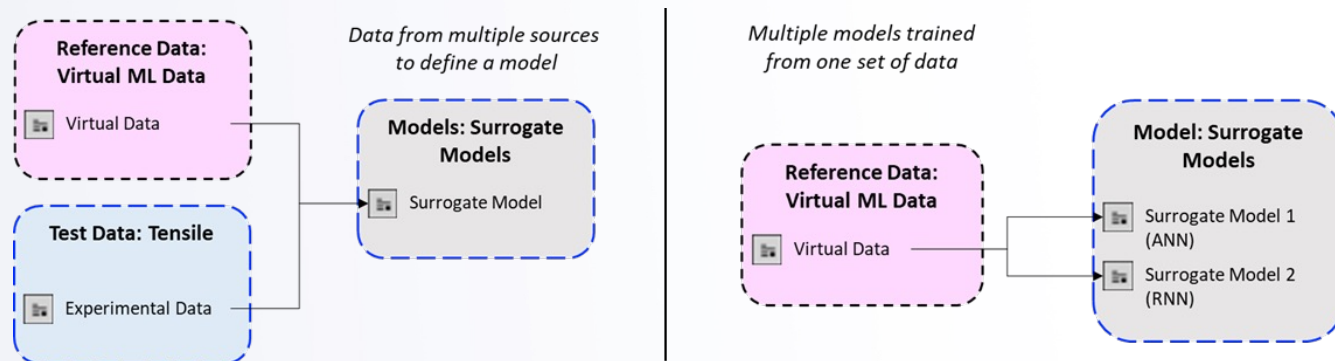

NASA TM-20220017137

- Developed import tools to facilitate data collection

- ML Models can have hundreds of thousands of data files → manual import not feasible
- Importer can ingest ML code and automatically determine and write the neural network architecture

model can be any variable

```
#Build Model
model = tf.keras.Sequential()
model.add(keras.layers.RepeatVector(100))
model.add(tf.keras.layers.Dense(units=170,activation = "relu"))
model.add(keras.layers.Dropout(rate=0.1))
model.add(tf.keras.layers.Dense(units=170,activation = "relu"))
model.add(keras.layers.Dropout(rate=0.1))
#model.add(tf.keras.layers.LSTM(units=300, return_sequences=True))
# NOTE: return_sequences = True needed for multiple LSTM layers
model.add(tf.keras.layers.LSTM(units=300, return_sequences=True))
model.add(tf.keras.layers.LSTM(units=300, return_sequences=True))
model.add(tf.keras.layers.LSTM(units=300, return_sequences=True))
model.add(tf.keras.layers.LSTM(units=300, return_sequences=True))
model.add(tf.keras.layers.Dense(units=1,activation = "linear"))

#Compile
model.compile(loss='mean_squared_error', optimizer=tf.keras.optimizers.Adam(1*10**-3.69))
```

.Dense adds a layer

options within .Dense have specific names

.add MUST be used to build model in tensorflow

.LSTM MUST be used for an RNN

options in .compile have specific names



Table auto-filled out in importer

Model Architecture

Architecture Type
Architecture Description
[Save as CSV](#) [Copy To Clipboard](#)

Label	Value
Predense Layers	2
Predense Units	170
Predense Dropout Rate	0.1
Predense Activation	relu
LSTM Layers	4
LSTM Units	300
LSTM Dropout Rate	0.0
LSTM Activation	relu
Postdense Layers	1
Postdense Units	1
Postdense Dropout Rate	0.0
Postdense Activation	linear
Learning Rate	10^-3
Loss Function	Mean Squared Error

[Save as CSV](#) [Copy To Clipboard](#)



Machine Learning Schema Allows for Dynamic Definition of Model Pedigree



- Proposed schema allows for data to be **defined** once in the database and **viewed** in each model → allows any member of a data set to be used in multiple models as training, test or validation without restoring the data
- Store all information (architecture, data split, optimization methods, etc.) to reproduce a model
 - Store model's location (Git, Box, etc.) for deployment as well

Model Architecture	
Architecture Type	Artificial Neural Network
Architecture Description	
Save as CSV Copy To Clipboard	
Label	Value
Dense Layers	3
Dense Units	120, 20, 1
Dense Layer Activation	tanh, tanh, linear
Loss	Mean Square Error
Save as CSV Copy To Clipboard	
Architecture Notes	

Data Assembly									
Hide table									
Save as CSV Copy To Clipboard									
Folder	Data Shuffle Equation	Data Shuffled	Training Split (%)	Validation Split (%)	Test Split (%)	Size			
Fatigue Life Estimator Data		42	80	10	10	100			
Save as CSV Copy To Clipboard									
Training Data Set (View)									
Hide table									
Record Name	Data Source	Attribute 1	Attribute 2	Attribute 3	Attribute 4	Attribute 5	Attribute 6	Attribute 7	Attribute 8
Fatigue Life Estimation 56	Virtual	400000	50000	0.34	0.34	60000	2500	0.25	0.4
Fatigue Life Estimation 45	Virtual	400000	50000	0.34	0.34	60000	2500	0.25	0.4
Fatigue Life Estimation 100	Virtual	700000	70000	0.4	0.4	100000	2500	0.25	0.4
Fatigue Life Estimation 20	Virtual	200000	30000	0.27	0.27	25000	2500	0.25	0.4
Fatigue Life Estimation 92	Virtual	700000	70000	0.4	0.4	100000	2500	0.25	0.4
Fatigue Life Estimation 32	Virtual	200000	30000	0.27	0.27	25000	2500	0.25	0.4

Dynamically *viewed* from ML: Data Table Records



Information Management Essential For Fit-For-Purpose Material Design



OUTLINE

Established Data Schema for ICME that Enables Linkage of Test Data with Simulation Data at Different Length Scales:

- Required establishment of Material Pedigree, Manufacturing, Microstructure, Model Pedigree, and Software Tools Tables within Granta MI
- Digital Thread / Digital Twin
- Six key **accomplishments**

Additive Manufacturing
ICMAMS 2023, Aug 9, 2023

Py-MILab (ICMAMS 2023, Aug 9, 2023)
Data Analytics and Importer

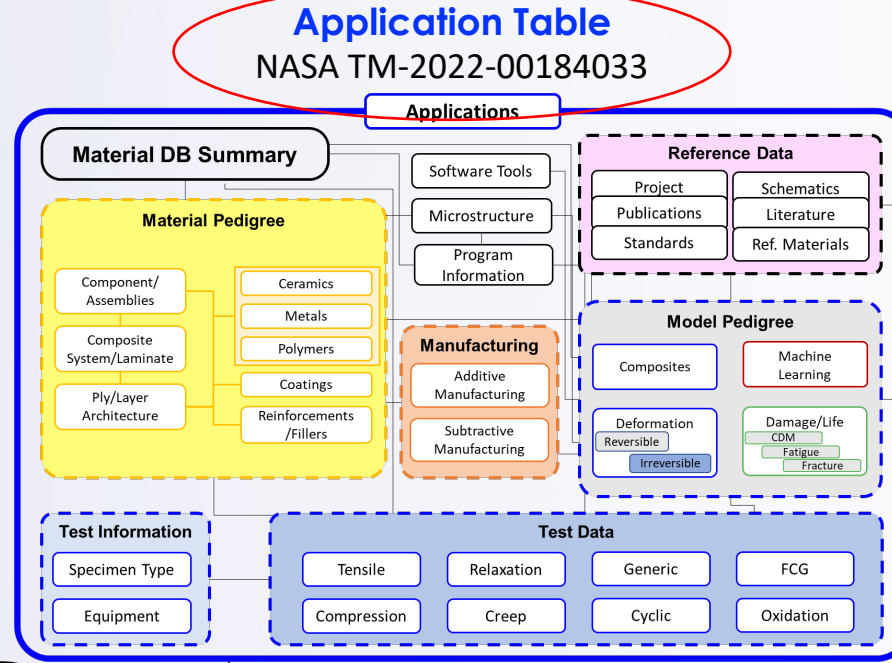
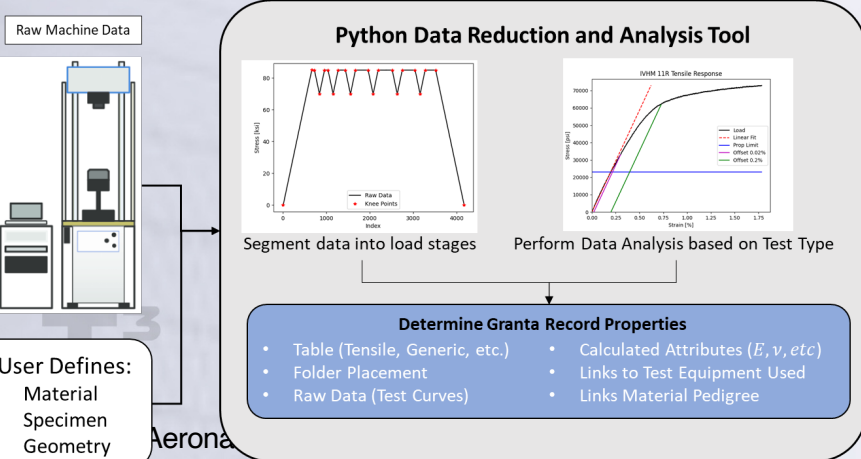

NASA GRC ICME Schema: Executive Summary
NASA TM-2023-0018337

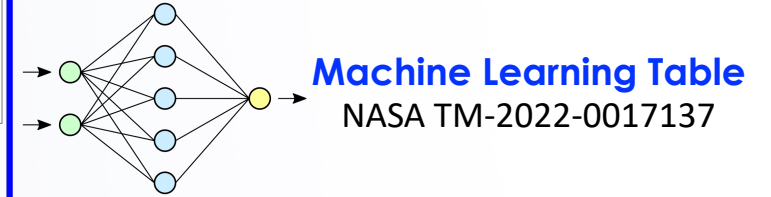

AIMAOS: Automated Information Management Across Organizations and Scales
(TMS ICME, May 21, 2023)

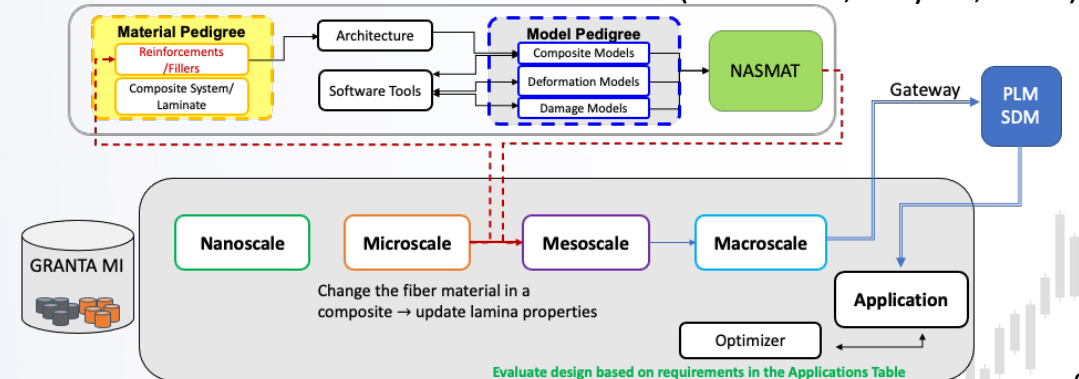

- Re-evaluate the requirements locally with periodic global (structural – PLM/SDM) updates

Application Table: Bridging the Gap Between Material Science and Structural Engineering

- The **Application Table** is the intended “bridge” between “**Designing the Material**” and “**Designing with the Material**” and is the “**brains**” for ICME
 - **Orchestrates the ICME Process - Drives optimization**
 - Contains information (e.g., application requirements) that can be used to drive the design and manufacture of “fit-for-purpose” materials
- Enables unique location to link CAD/PLM/SDM information to materials information as well as **BOM**
 - Assists in managing an organizations preferred materials
- Provides spatial and temporal information on application microstructure, residuals, damage, etc.
- Maintenance of the **Digital Thread**

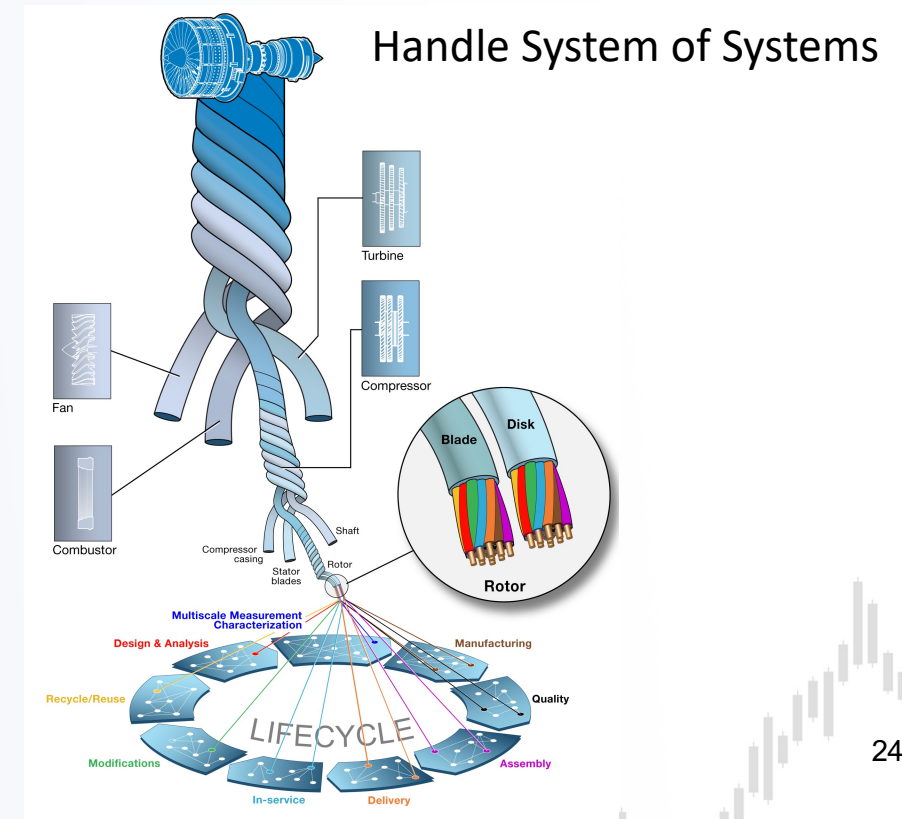
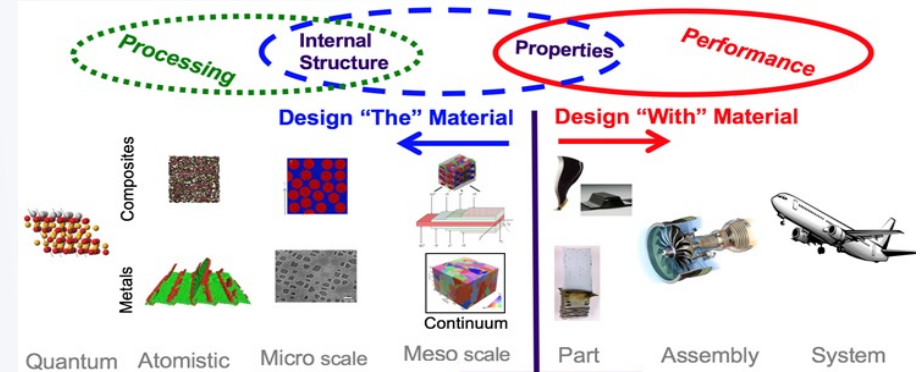



Application Table Schema

- Attributes and Layout defined to handle any type of application or requirements
 - Nine major categories specified with associated attributes
 - Associated requirements are dispersed throughout three major category (Geometric, Performance, Material)
 - Can be application-based or spatial (allow definition of design points)
 - Contains evaluation criteria (analysis performed and results)
 - Scorecards and Readiness Levels for the requirements
- Granta MI Tabular attribute type used extensively due to its flexibility and generality
 - Significant number of additional attributes associated with each column of a tabular attribute
 - Each row can represent different specifications

Attribute	Type	Attribute	Type
General Information		Analyses Performed	
Application Name	STXT	Analyses Performed	TABL
Application Description	LTXT	Analyses Performed (Subcomponents)	TABL
Data Ownership	DCT	Analyses Profiles	TABL
Data Ownership (Other)	STXT	Load Profiles	TABL
Distribution Category	DCT	Analyses Range Definitions	TABL
Funding Organization	STXT	Failure Mechanism/Modes	
Performing Organization	STXT	Failure Mode and Effect Analysis	TABL
Project Name	STXT	Material Selection	
Project Code	STXT	Material Requirements*	TABL
Project Notes	LTXT	Part List	TABL
Point of Contact	TABL	Bill of Materials*	TABL
Geometric/Manufacturing Requirements		Software Tools Used**	TABL
Owner Information	TABL	Selection Criteria	FILE
Surface Area	RNG	Property File	FILE
Volume	RNG	Material Selection Assumptions	LTXT
Bounding Box Dimensions	LTXT	Inspection	
CAD/CAE Link	HYP	Inspectability Notes	LTXT
Manufacturing Process	DCT	Evaluator	TABL
Manufacturing Process (Other)	STXT	NDE Method	DCT
Geometric Schematic Time History	TABL	NDE Geometry	TABL
Geometric Description	TABL	Equipment	TABL
Coordinate System Definitions	TABL	Examination	TABL
Design Points / Points of Interest*	TABL	Calibration	TABL
Geometric Notes	LTXT	Testing Parameters	TABL
Manufacturing Requirements*	TABL	NDE Images	TABL
Part Yield	RNG	NDE Comments	LTXT
Surface Treatment	DCT	NDE Information	FILE
Manufacturing Notes	LTXT	Scorecards	
Microstructure Profile	TABL	Requirements Scorecard*	TABL
Performance Requirements		Risk Scorecard*	TABL
Weight	RNG	Readiness Levels	
Life	RNG	Technology Readiness Level (TRL)	DCT
Cost	RNG	Manufacturing Readiness Level (MRL)	DCT
Risk	DCT	Integration Readiness Level (IRL)	DCT
Storage Energy	RNG	System Readiness Level (SRL)	DCT
Ultimate Strength	RNG	* Changed with feature request	
Performance Standards*	TABL	** Removed with feature request	
Mechanical Requirements*	TABL	DCT	Discrete Text (specified choices)
Thermal Requirements*	TABL	FILE	Allows the association of any file type to a given record
Environmental Requirements*	TABL	HYP	Hyperlink to a web address
Other Performance Requirements*	TABL	IMG	Allows the association of any image format to a given record
Performance Notes	LTXT	LTXT	Long Text Field
Form/Fit/Function Notes	LTXT	PNT	Point Value
		RNG	Range Variable
		STXT	Short Text Field
		TABL	Tabular Attribute



Application Table Orchestrates ICME By Linking Processing, Microstructure, Properties, and Performance

- Application Table links part requirements, microstructure information, material properties, geometry, employed models, relevant analysis, and performance

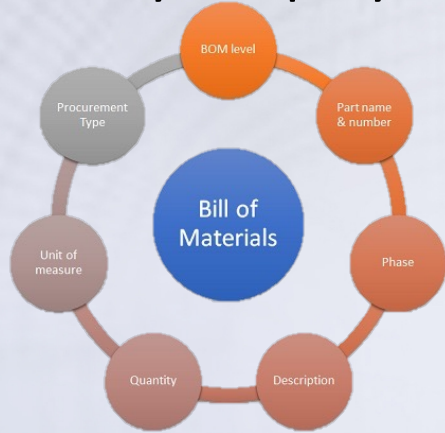

Summary of material properties

Application

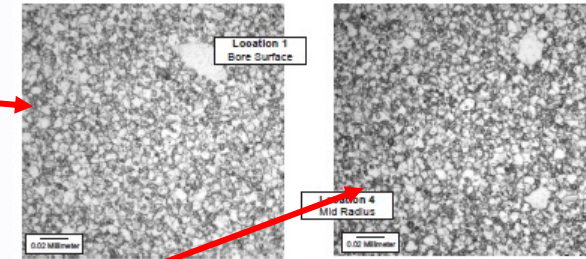
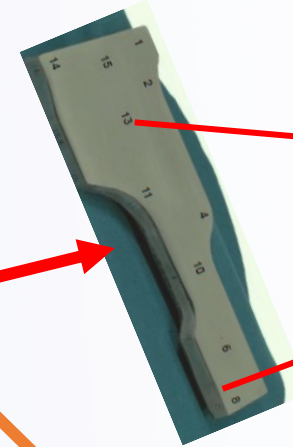

Spatially Microstructure Characterization

Part Geometry

Assembly	Designed Schematic	Designed Measurements/Tolerances
D1		Inner Radius = 86.0 in +/- 0.005 in Outer Radius = 101.5 in +/- 0.05 in
D1		Inner Radius = 290.0 in +/- 0.05 in Outer Radius = 302.0 in +/- 0.01 in

Performance Requirements

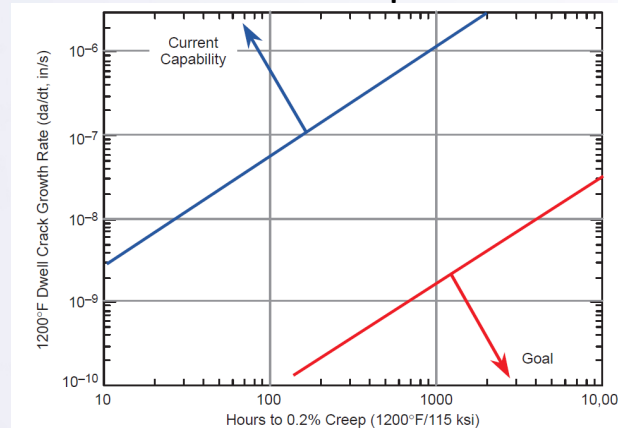

Summary of Relevant Analyses with Links to PLM/SDM

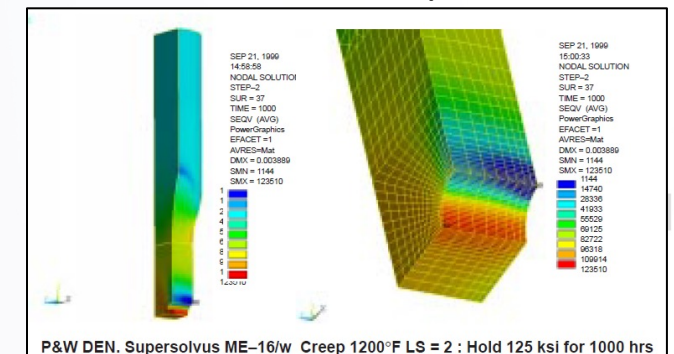

Scorecards/Readiness Levels



- The Scorecards header give a summary of the status of every requirement for the given application

Requirements Scorecard [Hide table](#)

Requirement Type	Requirement Name	Component / Zone	Design Point 1	Design Point 2	Design Point 3	Design Point 4	Design Point 5	Design Point 6	Design Point 7
Mechanical	Creep vs Crack Growth	Met	Could apply to the whole part or individual design points						
Mechanical	Safety Factor		5.0	3.5	1.9	1.8	1.7	1.6	1.5
Thermal	Stress vs Temperature	Met	Could be logical (Met/Not Met) or a margin						
Material	Maximum Temperature		Not Met	Not Met	Met	Met	Met	Met	Met

- Final section further summarizes the application through the various readiness levels

- Provide traceability as to why we're at a certain readiness levels from scorecards
- Assess what level we're at

Readiness Levels	
Technology Readiness Level (TRL)	TRL 4
Manufacturing Readiness Level (MRL)	MRL 3
Integration Readiness Level (IRL)	IRL 5
System Readiness Level (SRL)	SRL 3

Integration Readiness Levels

Level	IRL Description
1	An interface between technologies has been identified with sufficient detail to allow characterization of the relationship.
2	There is some level of specificity to characterize the interaction between technologies through their interface.
3	There is compatibility between technologies to orderly and efficiently integrate and interact.
4	There is sufficient detail in the quality and assurance of the integration between technologies.
5	There is sufficient control between technologies necessary to establish, manage, and terminate the integration.
6	The integrating technologies can accept, translate, and structure information for its intended application.
7	The integration of technologies has been verified and validated with sufficient detail to be actionable.



Information Management Essential For Fit-For-Purpose Material Design



OUTLINE

Application Table

NASA TM-2022-00184033

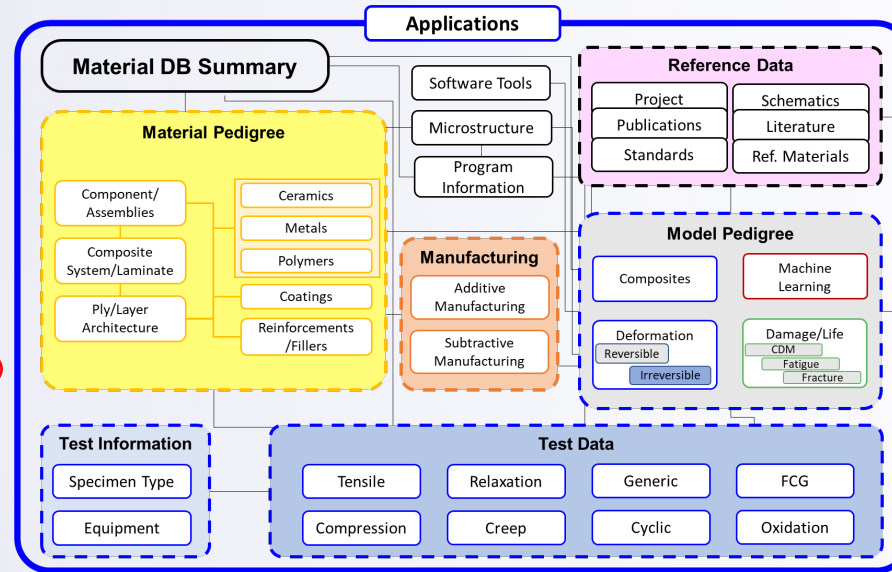

NASA GRC ICME Schema: Executive Summary

NASA TM-2023-0018337

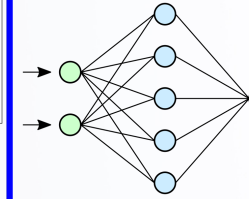

Machine Learning Table

NASA TM-2022-0017137

AIMAOS: Automated Information Management Across Organizations and Scales (TMS ICME, May 21, 2023)

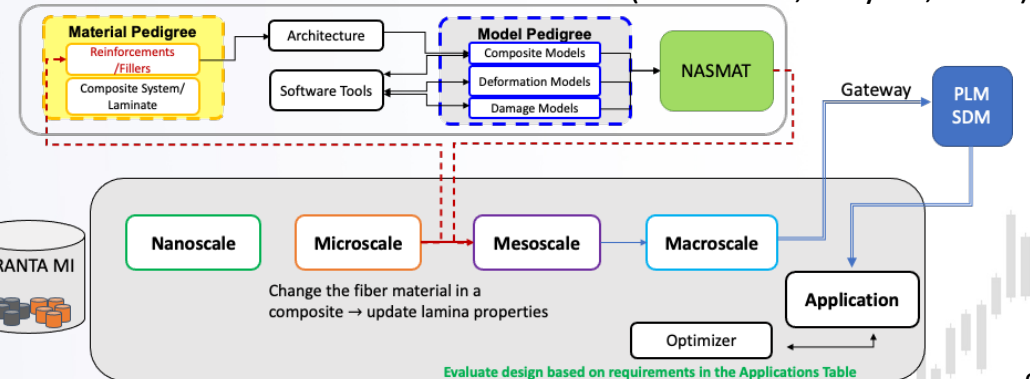

Established Data Schema for ICME that Enables Linkage of Test Data with Simulation Data at Different Length Scales:

- Required establishment of Material Pedigree, Manufacturing, Microstructure, Model Pedigree, and Software Tools Tables within Granta MI
- Digital Thread / Digital Twin
- Six key **accomplishments**

Additive Manufacturing
ICMAMS 2023, Aug 9, 2023

Py-MILab (ICMAMS 2023, Aug 9, 2023)
Data Analytics and Importer

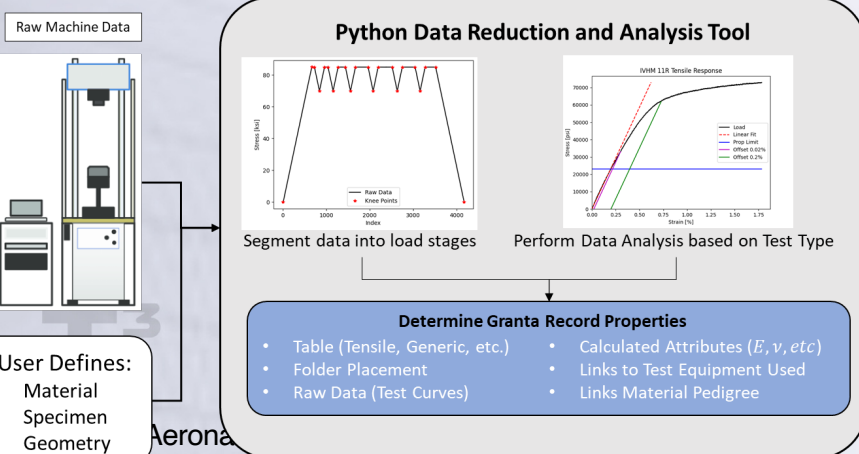

- Re-evaluate the requirements locally with periodic global (structural – PLM/SDM) updates

Extending Pedigree and Application Table to Additive Manufacturing



- Application Table allows for definition of spatially varying properties/microstructure
 - Paired with an optimization tool → design “fit-for-purpose” materials with improved properties in critical areas
- Achieve varying microstructure in applications through additive manufacturing
 - Need to understand and link together processing parameters, resultant microstructure, and performance
- Schema was adapted to allow for definition of additive manufacturing processes and applied to the Application Table
 - Established new tables for manufacturing methods
 - Designed based on NASA Standard 6030 for Additive Manufactured Materials
 - **Store additive and subtractive in same schema → easily capture assemblies with parts made from both methods**

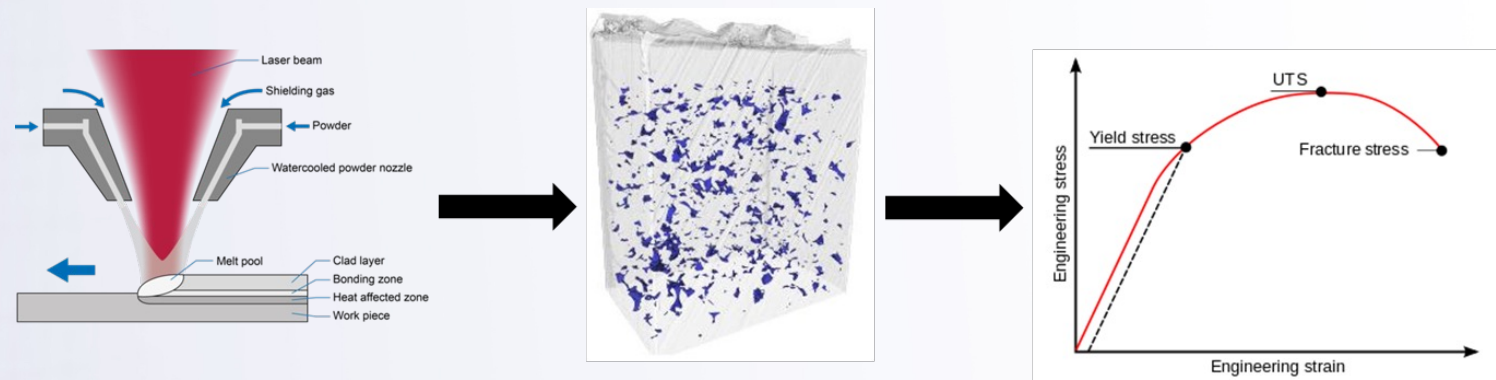

Schema Workflow for Additive Manufacturing

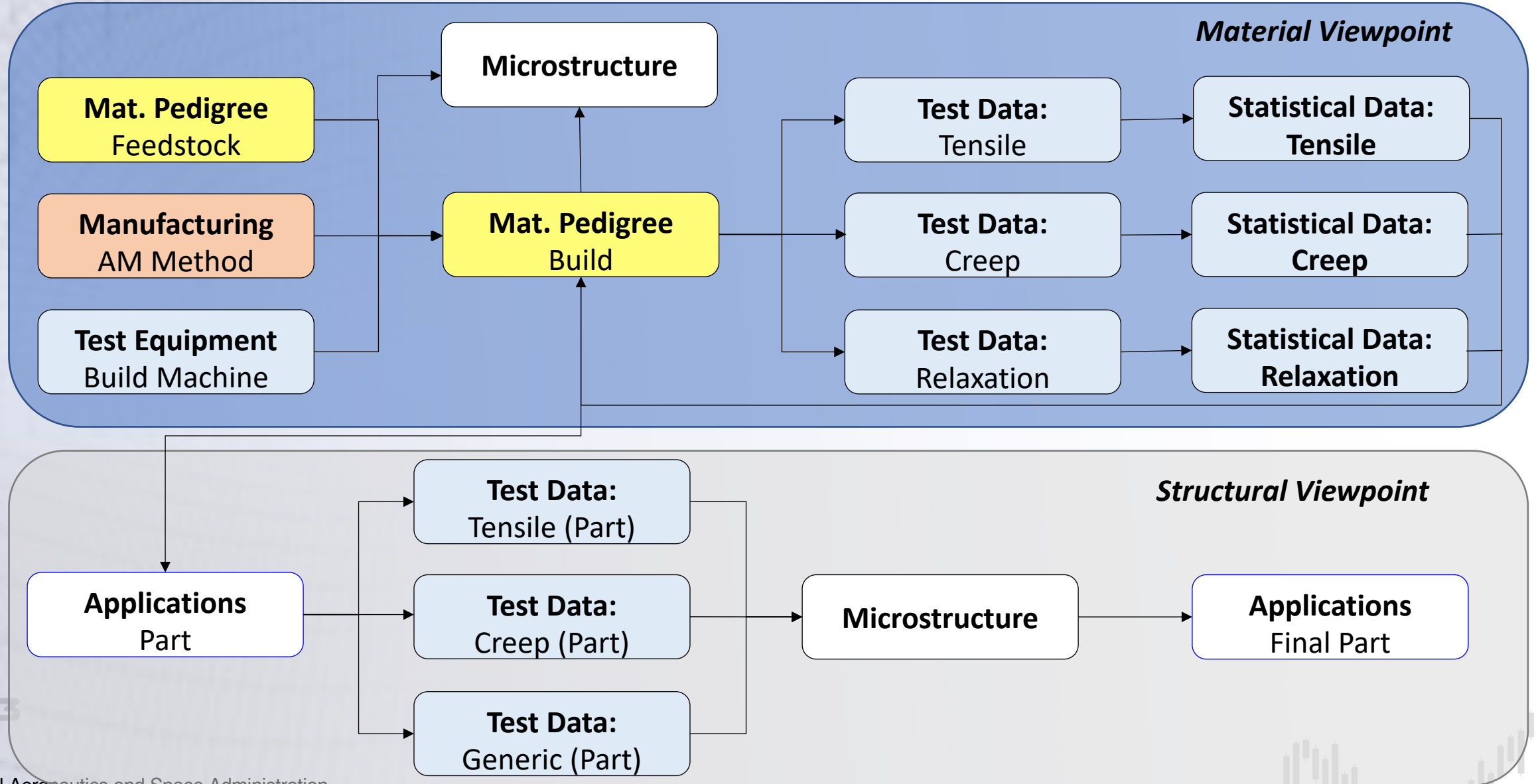

Example Workflow for Additive Manufacturing

Powder Microstructure Characterization

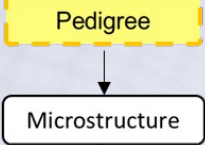
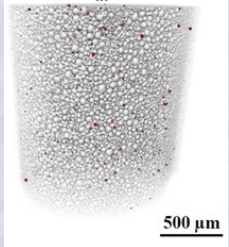

Perform Multiple Builds to determine Process Window

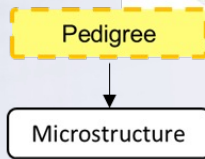
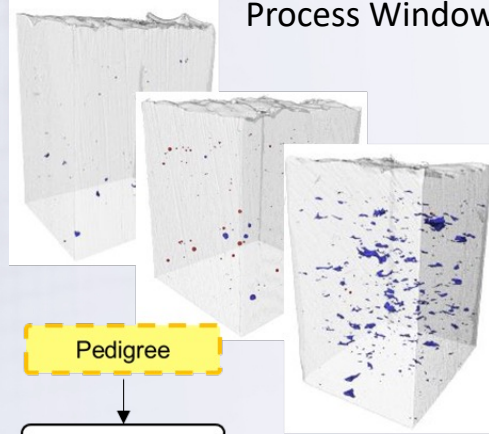

Define Build Parameters

Method Name	Method Type	Feedstock Type	Parameter	Range	Units	Parameters Used
Laser Powder Bed Fusion	Melt-Based	Powder	Deposition Rate	12.5 < x < 33.3	mm ³ /s	15
			Power	150 < x < 400	W	280
			Laser Speed	200 < x < 2000	mm/s	1200
			Layer Thickness	25 < x < 65	μm	30
			Hatch Spacing	20 < x < 250	μm	140

Viewed from Manufacturing Table
Defined for each build record

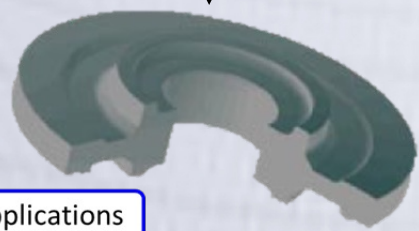
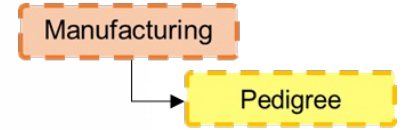

Applications

Design Final Part

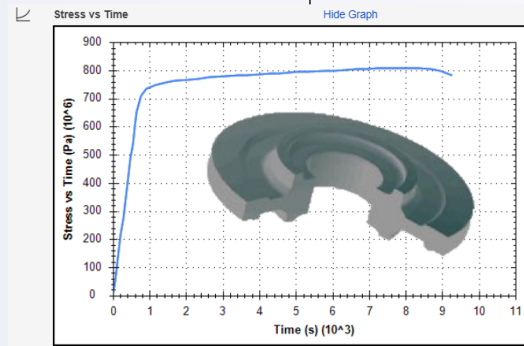

Design, Build, and Test Witness Articles

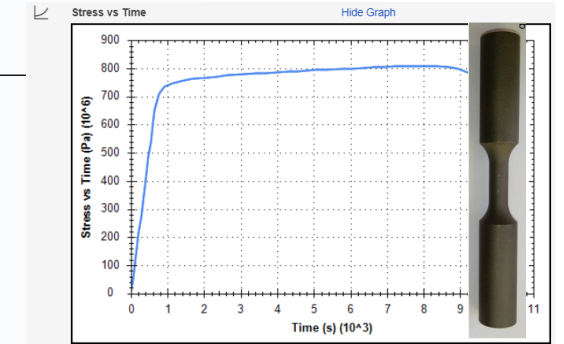
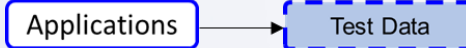

Perform Characterization Tests



Information Management Essential For Fit-For-Purpose Material Design

OUTLINE



Established Data Schema for ICME that Enables Linkage of Test Data with Simulation Data at Different Length Scales:

- Required establishment of Material Pedigree, Manufacturing, Microstructure, Model Pedigree, and Software Tools Tables within Granta MI
- Digital Thread / Digital Twin
- Six key **accomplishments**

Additive Manufacturing
ICMAMS 2023, Aug 9, 2023

Py-MILab (ICMAMS 2023, Aug 9, 2023)
Data Analytics and Importer

Application Table
NASA TM-2022-00184033

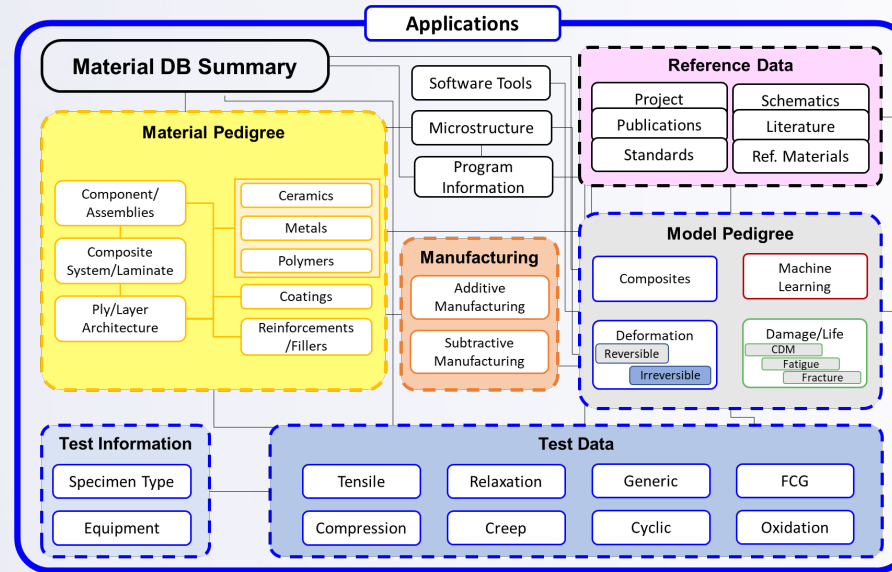

NASA GRC ICME Schema: Executive Summary
NASA TM-2023-0018337

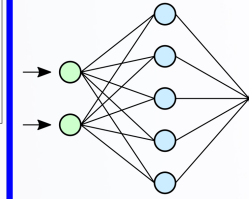

Machine Learning Table
NASA TM-2022-0017137

AIMAOS: Automated Information Management Across Organizations and Scales
(TMS ICME, May 21, 2023)

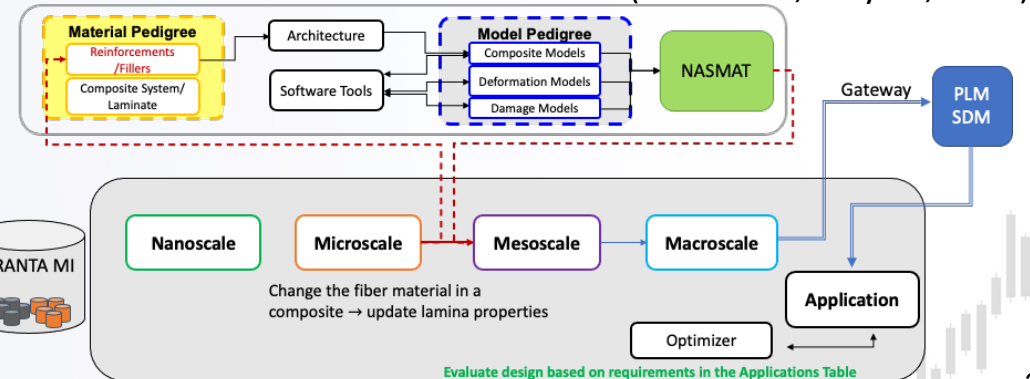

Evaluate design based on requirements in the Applications Table

- Re-evaluate the requirements locally with periodic global (structural – PLM/SDM) updates

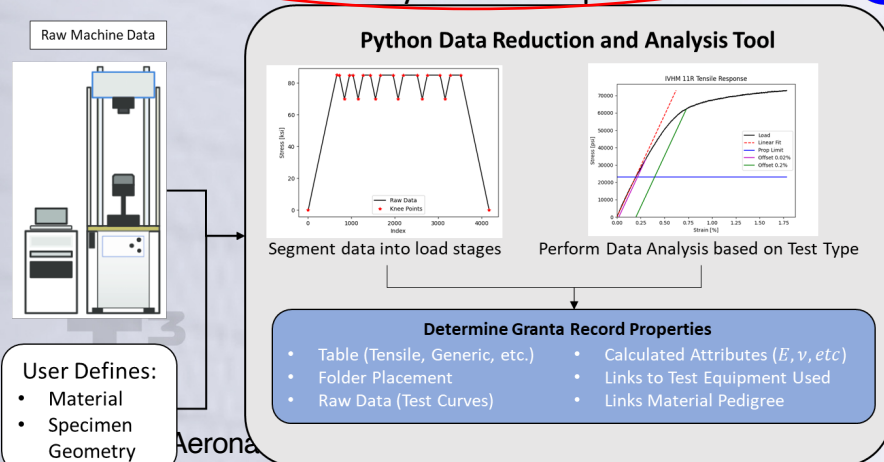

Tackling Cultural/Workforce Challenges for Digital Transformation



Development of Database Auxiliary Tools

- NASA Vision 2040 outlined both **technical** and **cultural challenges** for implementing ICME Data Management
 - If data is not findable, accessible, interoperable, and reusable (FAIR principles), it will not be useful
 - People don't like to change how they currently store their data
- The development of import/export tools is critical for cultural adoption of digital transformation
 - Ensure data is uploaded to the right place and exported in the right format
- At NASA GRC, import tools also offer **additional features** that facilitate capturing and analyzing data to further promote adoption

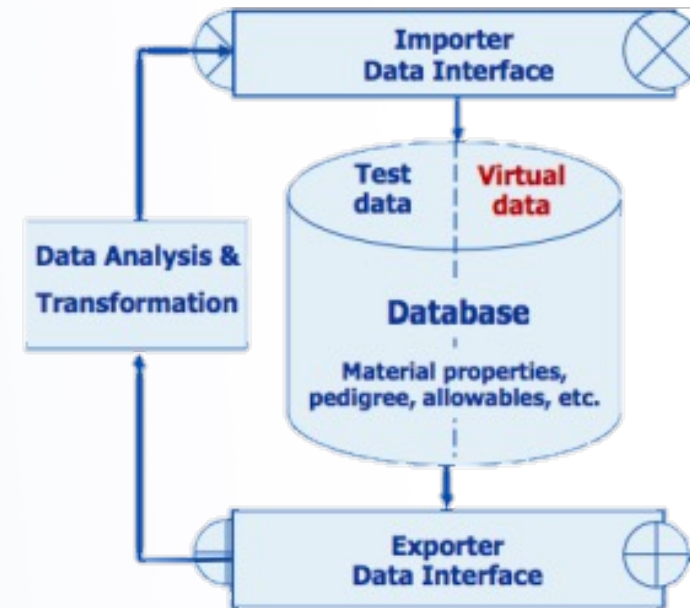

PyMILAB: Analyzing and Storing Test Data

- Developed PyMILAB:
 - Python-based GUI Tool
 - Reads raw test data and user input
 - Performs data analysis
 - Stores the data automatically
- Enables consistent data reduction
- Able to perform automatic segmentation for complex load histories
 - User has ability to edit within the GUI
- Individual analysis subroutines for each load type (tension, compression, creep, relaxation)

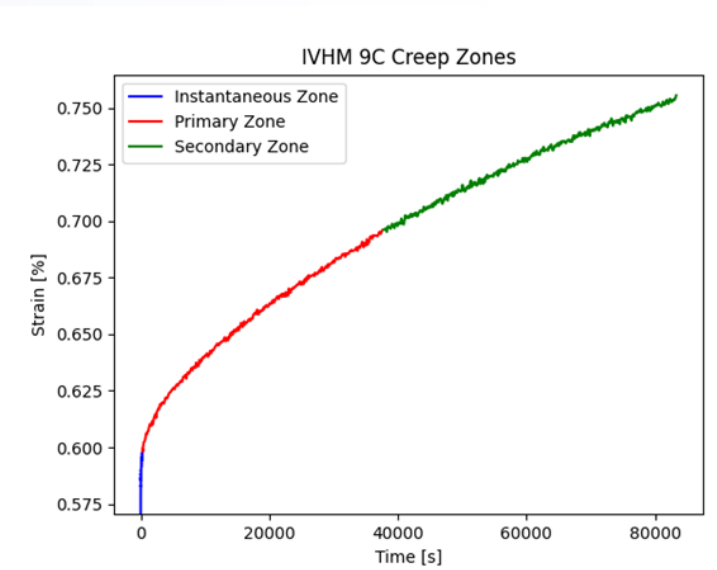
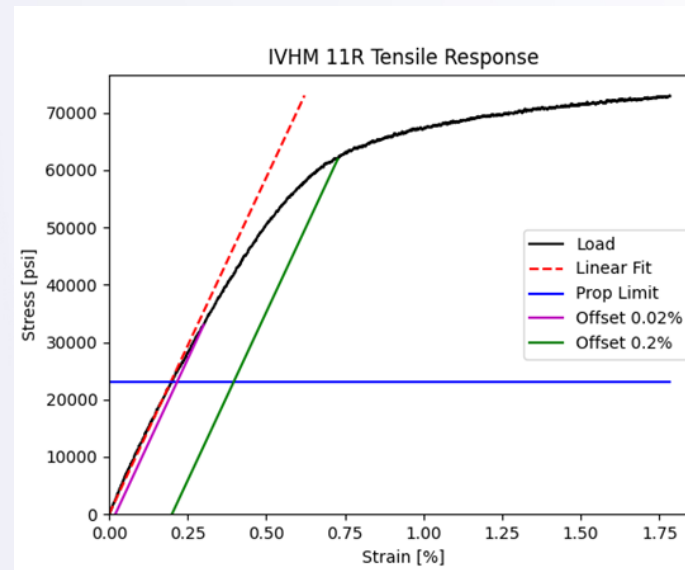
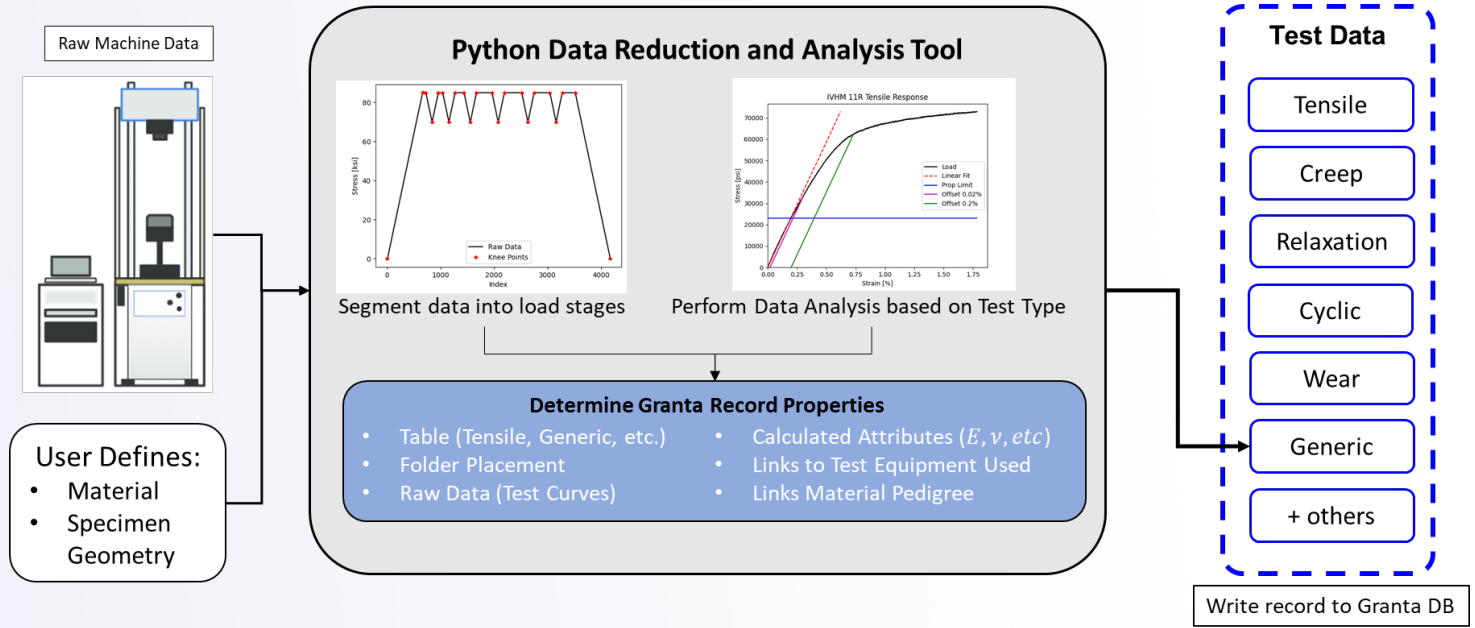

Experimental Data Automatic Import Tool: Defining Generic Tests

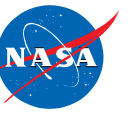

- Generic Tests contain various stages of one of the standard test types
 - Stages endpoints are automatically recognized by implementing a knee-point algorithm
 - Control Modes are determined from analyzing the stress-time and strain-time behavior of each stage
 - Stage Type is determined using the table below

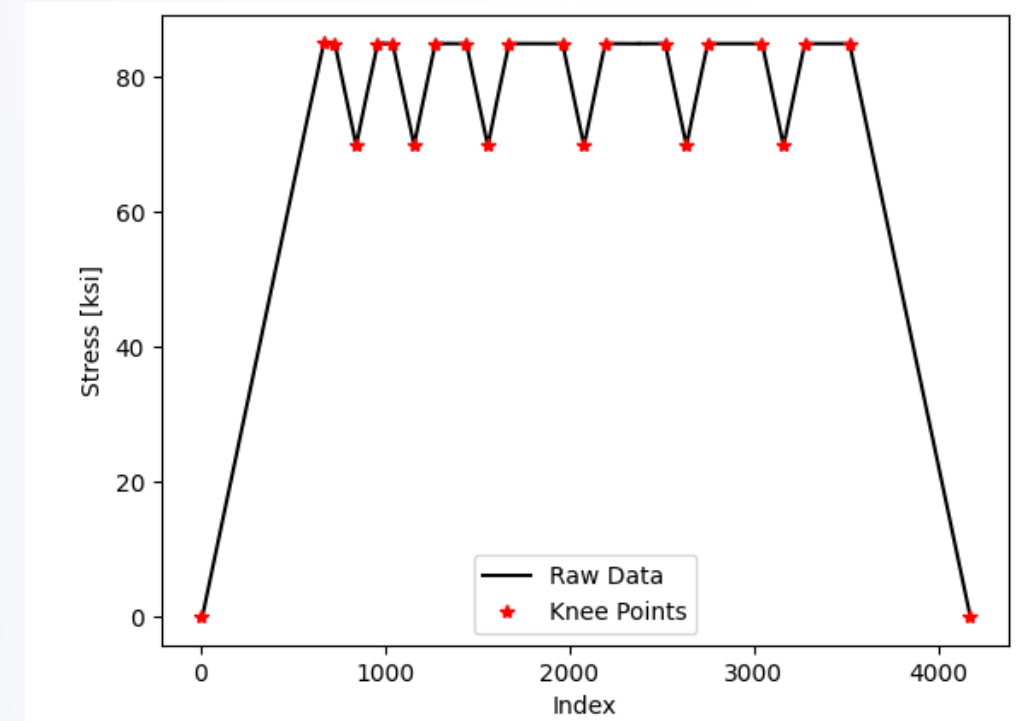

Control Mode	Rule	Stage Type
Stress	$ \dot{\sigma} < 10^{-3} \text{ ksi/s}$	Creep
Strain	$\dot{\epsilon} < 10^{-8} \%/\text{s}$	Relaxation
Stress or Strain	$\dot{\sigma} > 0$ and $\sigma_{end} > 0$ or $\dot{\epsilon} > 0$ and $\epsilon_{end} > 0$	Tensile Loading
Stress or Strain	$\dot{\sigma} < 0$ and $\sigma_{end} > 0$ or $\dot{\epsilon} < 0$ and $\epsilon_{end} > 0$	Tensile Unloading
Stress or Strain	$\dot{\sigma} < 0$ and $\sigma_{end} < 0$ or $\dot{\epsilon} < 0$ and $\epsilon_{end} < 0$	Compressive Loading
Stress or Strain	$\dot{\sigma} > 0$ and $\sigma_{end} < 0$ or $\dot{\epsilon} > 0$ and $\epsilon_{end} < 0$	Compressive Unloading



PyMLab GUI Combines Automation with User Input for Efficient and Accurate Analysis



- Users can edit the stages manually through the GUI if desired

Add/Delete stages through the table

Stage	Stage Name	Stage Type	Control Mode	Target Strain [%]	Target Stress [ksi]	End Time [s]	End Index
1	Stage_0	Tensile Loading	Stress	2.12	85.01	7.86	667
2	Stage_1	Creep	Stress	2.51	84.95	199.942	728
3	Stage_2	Tensile Unloading	Stress	2.38	69.89	201.112	845
4							
5	Stage_3		Stress	2.51	84.91	202.258	960
6	Stage_4		Stress	4.01	84.93	2629.538	1041
7	Stage_5		Stress	3.88	69.91	2630.708	1158
8	Stage_6		Stress	4.01	84.94	2632.854	1274
9	Stage_7		Stress	6.02	84.95	15369.414	1439
10	Stage_8		Stress	5.89	69.89	15370.594	1557
11	Stage_9		Stress	6.02	84.95	15372.74	1673
12	Stage_10		Stress	8.02	84.95	42786.322	1961
13	Stage_11	Tensile Unloading	Stress	7.89	69.9	42787.492	2078
14	Stage_12	Tensile Loading	Stress	8.02	84.95	42790.638	2195
15	Stage_13	Creep	Stress	10.03	84.94	74260.182	2516
16	Stage_14	Tensile Unloading	Stress	9.89	69.88	74261.352	2633
17	Stage_15	Tensile Loading	Stress	10.03	84.95	74263.498	2749
18	Stage_16	Creep	Stress	12.03	84.94	102191.064	3042
19	Stage_17	Tensile Unloading	Stress	11.89	69.88	102192.234	3159
20	Stage_18	Tensile Loading	Stress	12.03	84.94	102196.38	3277
21	Stage_19	Creep	Stress	14.04	84.94	123857.302	3515

Only need to fill in end time or index → program will reanalyze and fill in row



PyMLab GUI Combines Automation with User Input for Efficient and Accurate Analysis

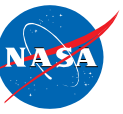

- Endpoints can be edited through the graph as well

Stage Name	Stage Type	Control Mode	Target Strain [%]	Target Stress [ksi]	End Time [s]	End Index
1 Stage_0	Tensile Loading	Stress	2.12	85.01	7.86	667
2 Stage_0	Tensile Loading	Stress	2.51	84.95	199.942	728
3 Stage_0	Tensile Loading	Stress	2.18	84.92	16.86	677
4 Stage_0	Tensile Loading	Stress	4.01	84.93	2629.538	1041
5 Stage_0	Tensile Loading	Stress	4.01	84.93	2630.708	1158
6 Stage_0	Tensile Loading	Stress	4.01	84.93	2632.854	1274
7 Stage_0	Tensile Loading	Stress	4.01	84.93	15369.414	1439
8 Stage_0	Tensile Loading	Stress	4.01	84.93	15370.594	1557

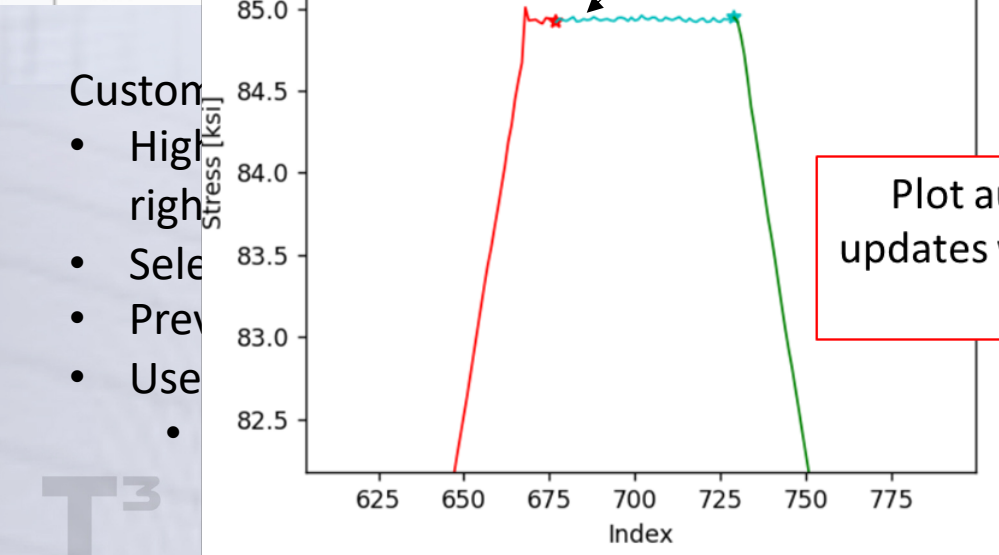

Old

New

Table automatically updates values

Endpoint removed

Manual editing exited with "Done Editing Stages" Button

When stage editing is done, the program begins the import process to the database

Done Editing Stages

Index ▾

Stress [ksi] ▾

Plot

- Custom
- High
- High
- Sele
- Prev
- Use



Information Management Essential For Fit-For-Purpose Material Design

OUTLINE



Established Data Schema for ICME that Enables Linkage of Test Data with Simulation Data at Different Length Scales:

- Required establishment of Material Pedigree, Manufacturing, Microstructure, Model Pedigree, and Software Tools Tables within Granta MI
- Digital Thread / Digital Twin
- Six key **accomplishments**

Additive Manufacturing
ICMAMS 2023, Aug 9, 2023

Py-MILab (ICMAMS 2023, Aug 9, 2023)
Data Analytics and Importer

Application Table
NASA TM-2022-00184033

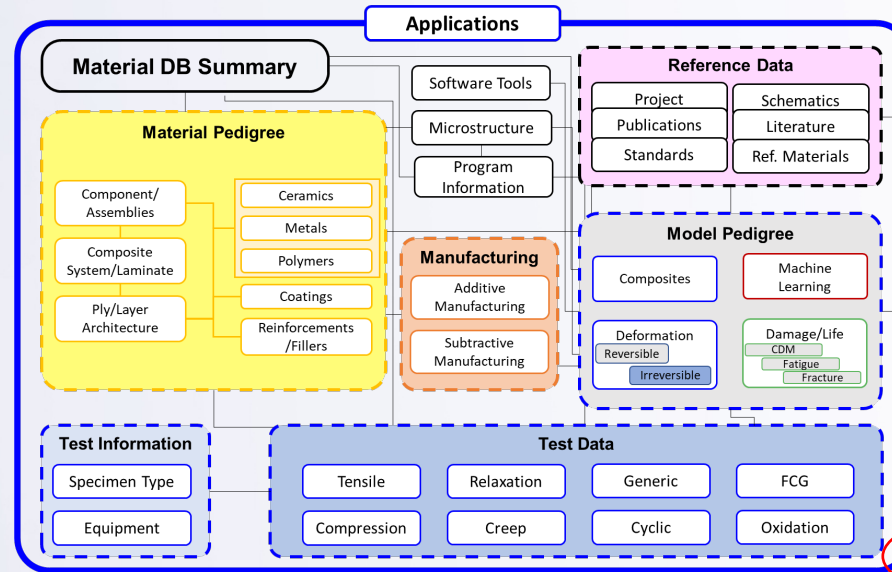

NASA GRC ICME Schema: Executive Summary
NASA TM-2023-0018337

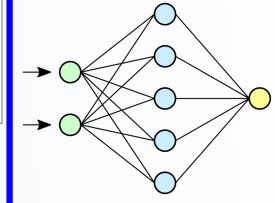

Machine Learning Table
NASA TM-2022-0017137

AIMAOS: Automated Information Management Across Organizations and Scales
(TMS ICME, May 21, 2023)

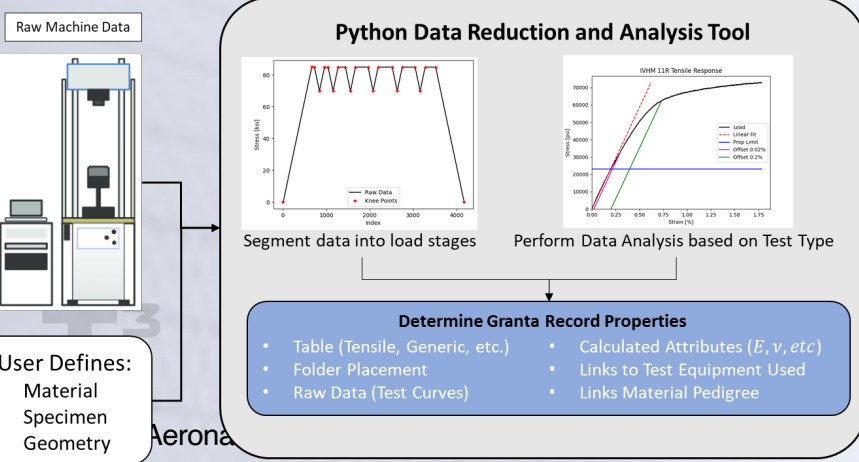
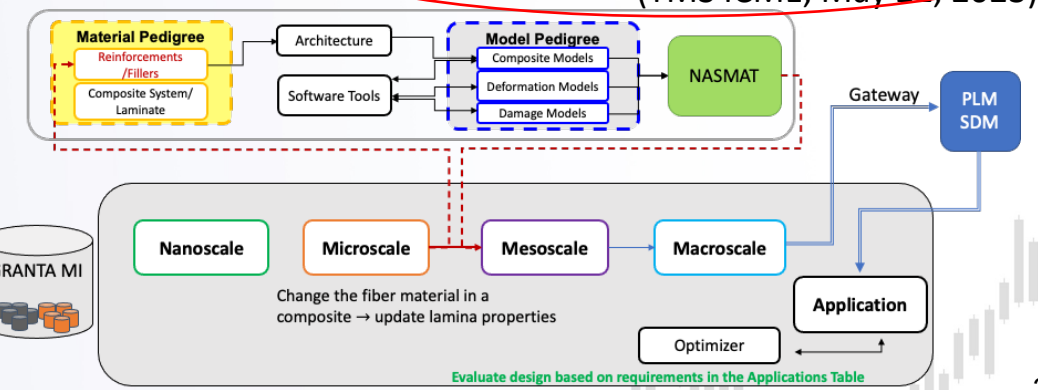

- Re-evaluate the requirements locally with periodic global (structural – PLM/SDM) updates

Traditional Database/Simulation Management Only Deals with a Single Scale

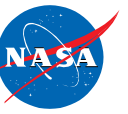

- Select a known material based on application requirements
 - Use macroscale material properties (which incorporate all lower length scales effects)
- Iterate on the structural design until requirements in the PLM/SDM are met
 - If requirements cannot be met, select a new material

Material and Structure viewpoints are non-concurrent!

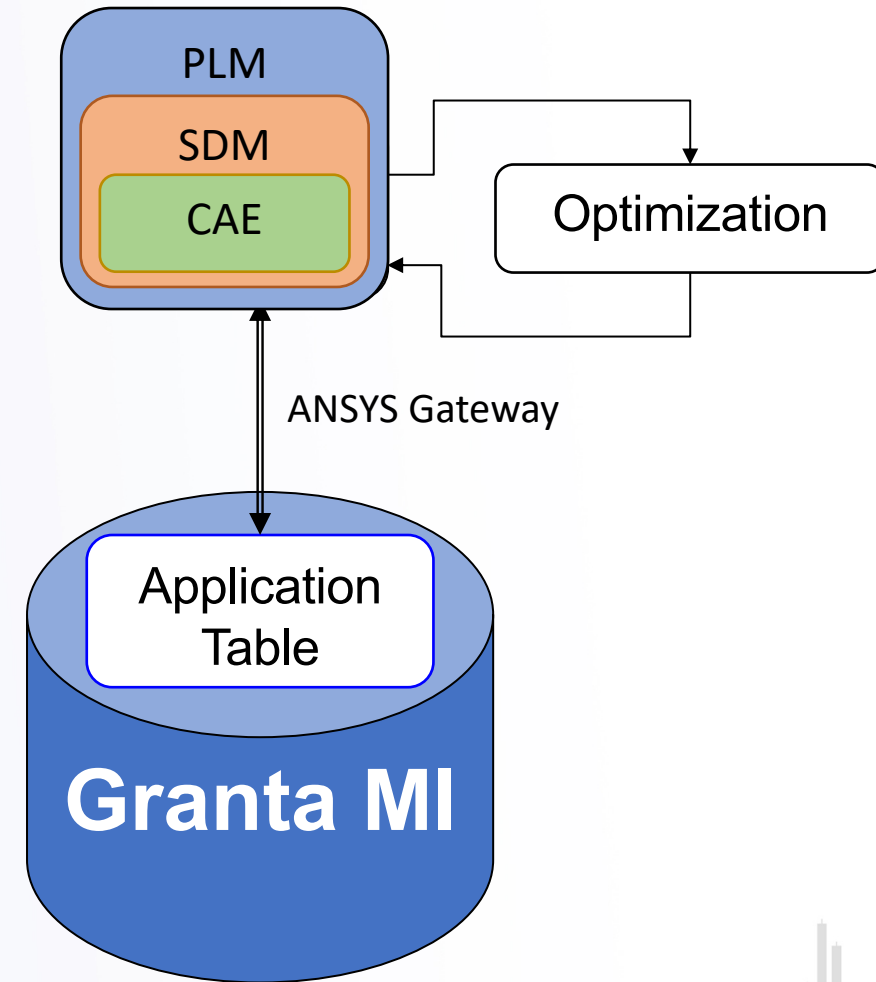

AIMAOS: Digital Thread Maintenance Tool

- **AIMAOS** – **A**utomatic **I**nformation **M**anagement **A**cross **O**rganizations and **S**cales
 - Digital thread maintenance tool which orchestrates the ICME process through judicious automation, across organizations and scales
- Goal: Connect multiscale material information in the database with simulation tools to optimize material design and create/maintain digital twins at each length scale

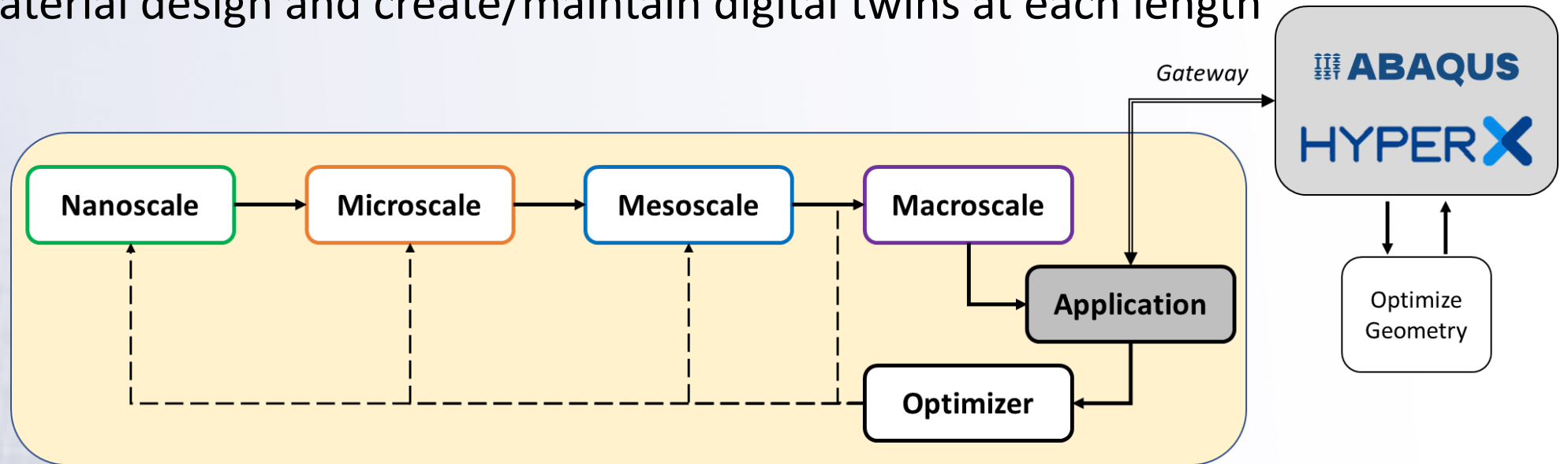

Ongoing Project: ICME Optimization of Advanced Composite Components of the Aurora D8 Aircraft: Digital Twin/Digital Thread



Multi Org. Collaboration: Univ Mass Lowell, Univ Michigan Tech, NASA, Aurora, Collier

- Objective is to develop an **integrated approach** to design and optimize the composite Y-joints and composite acreage panels used in the Aurora D8 aircraft
- Approach link material models, structural models, and experiments at multiple length scales
- Benchmark problem will serve to demonstrate the benefits of the ICME (compare to traditional approach)
 - **Digital Twins** at each scale
 - Input/output from each scale will constitute the **digital thread** of this ICME framework
- Won the 2022 AIAA ICME Prize, work is continuing under an NRA with NASA GRC to further study/refine this work
- Use case within AIAA Digital Twin Implementation paper (Multiscale – ICME Schema)

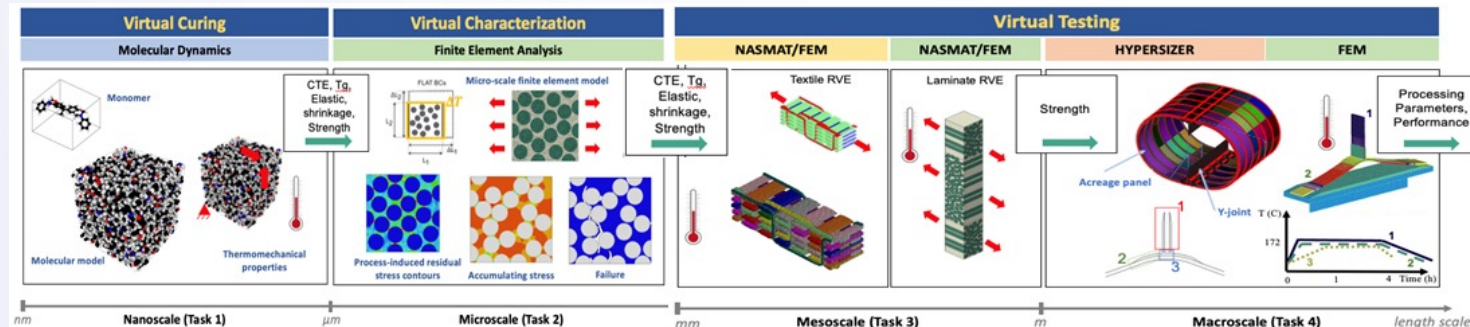
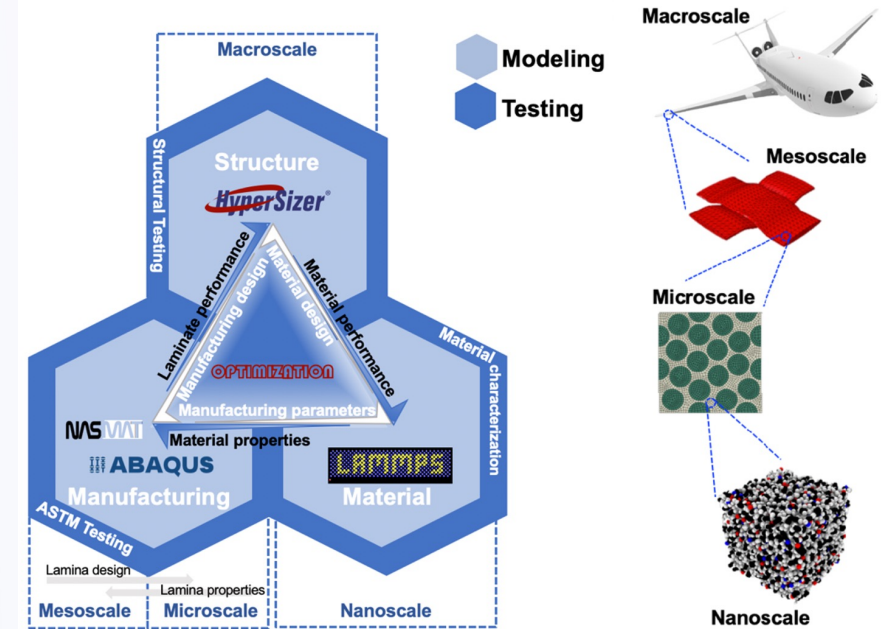

AIMAOS Methodology

- Create a Python-based tool that can store information, write input decks, and read output decks across the various scales
- Develop a GUI so users can easily navigate through the different scales as changes occur and
- Store **digital twins** at each scale as input/output decks between tool sets
- Establish minimum metadata to describe a **digital twin** and distinguish from a **digital representation** as time evolves

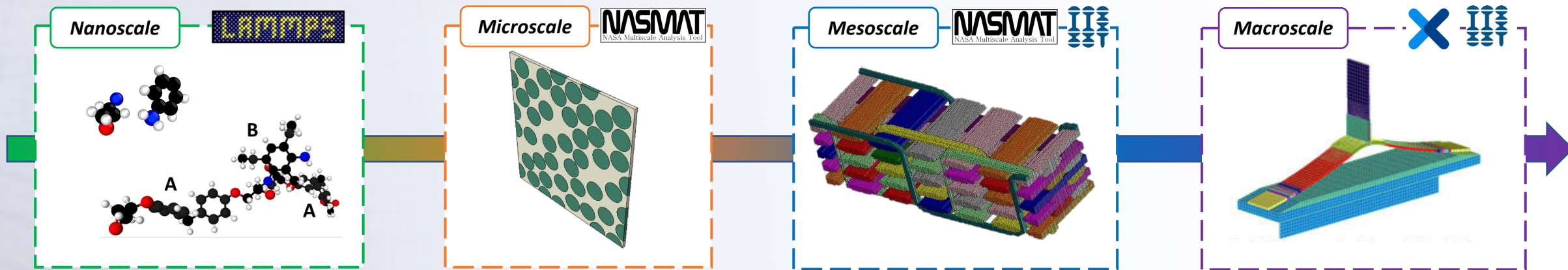

- Resin chemistry as a function of cure

- Define fiber and resin properties
- Determine lamina effective properties

- Determine laminate effective properties and allowables

- Apply structural loads
- Optimize geometry
- Evaluate the design

AIMAOS assists Digital Thread Management in ICME



- Consider changing the material characteristics at lower scales
- Optimization can either change material choice, processing method, or structural design
 - Designing **the material** for the **application**

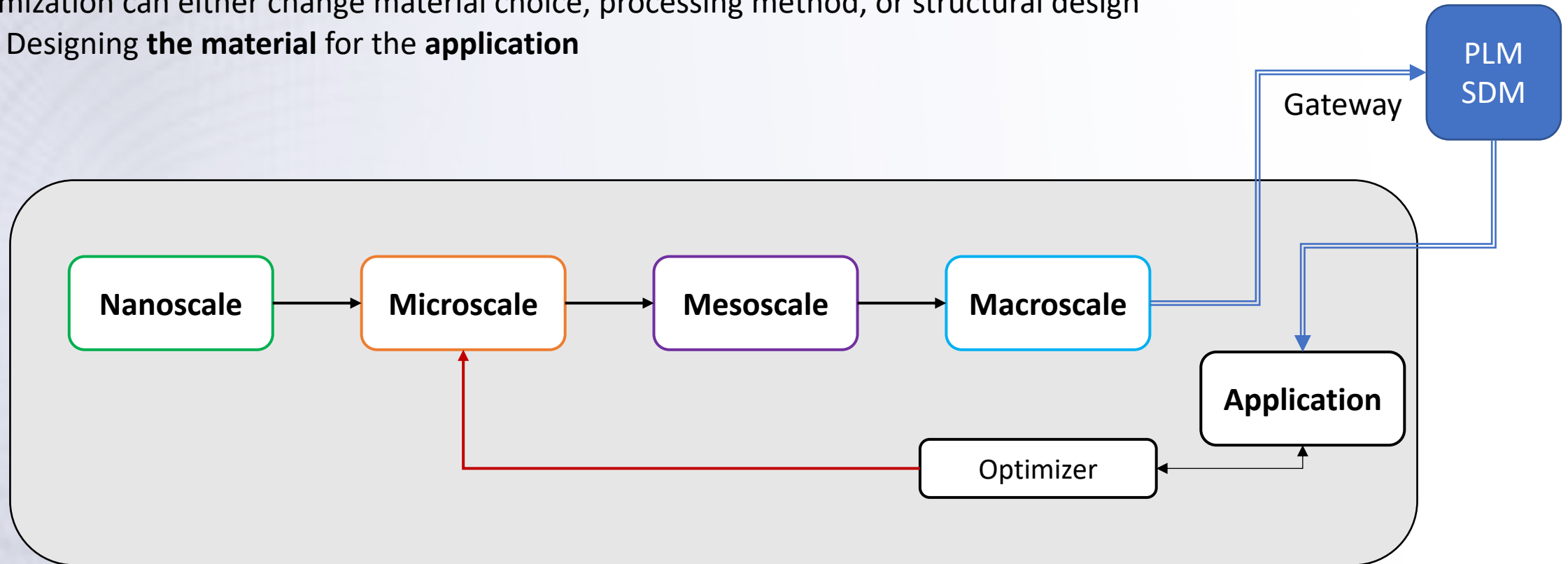

Illustrate with Example in which the **fiber reinforcement of a composite material** used for a structural component is varied

Database/Simulation Management in ICME

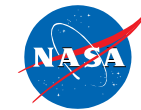

Automation of read/write and tool execution in background

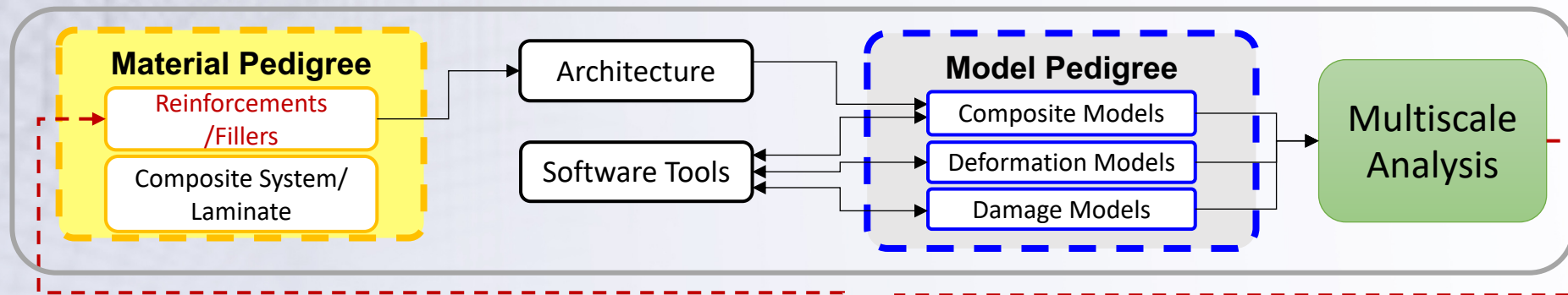

PLM
SDM

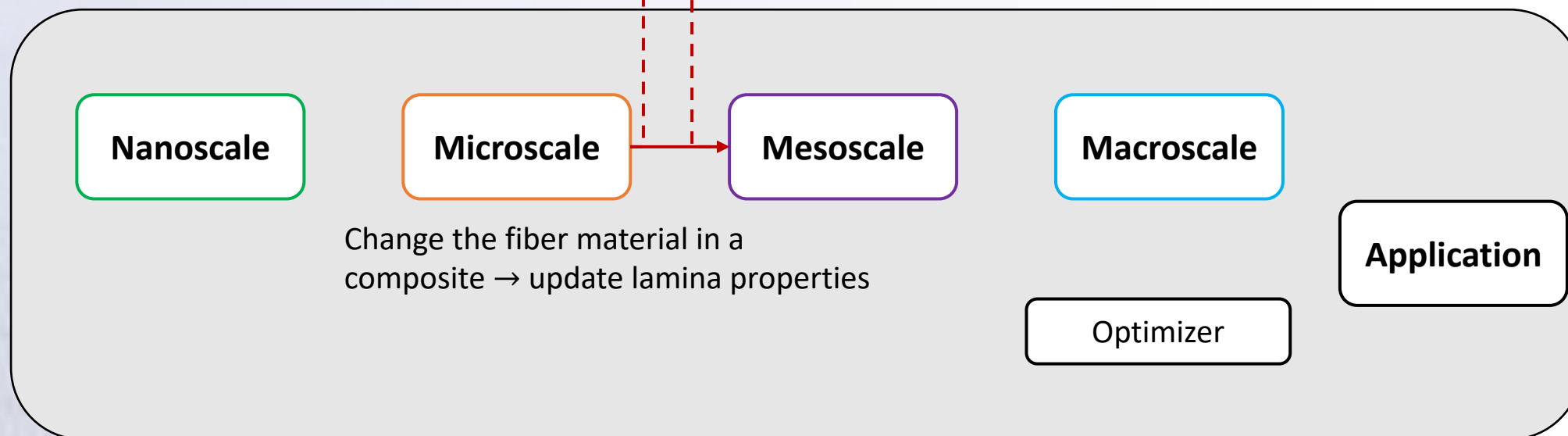

Database/Simulation Management in ICME



Automation of read/write and tool execution in background

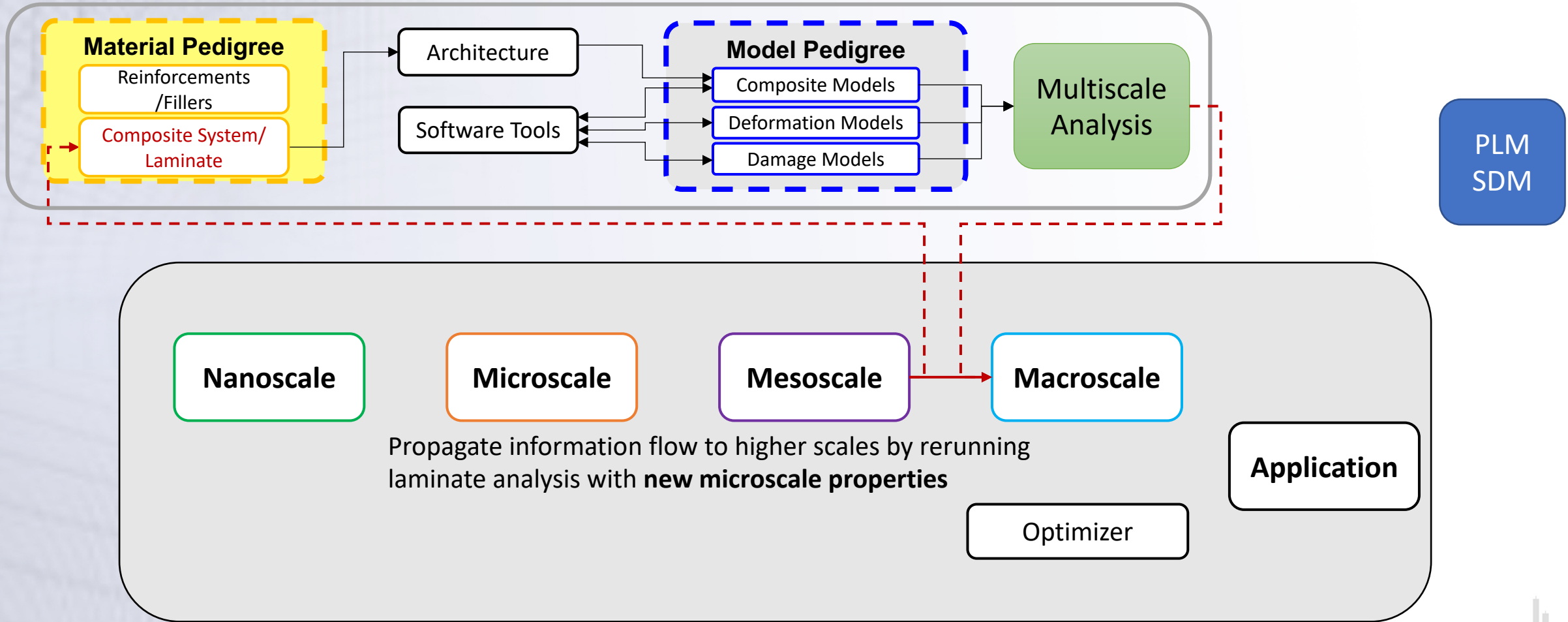

Database/Simulation Management in ICME

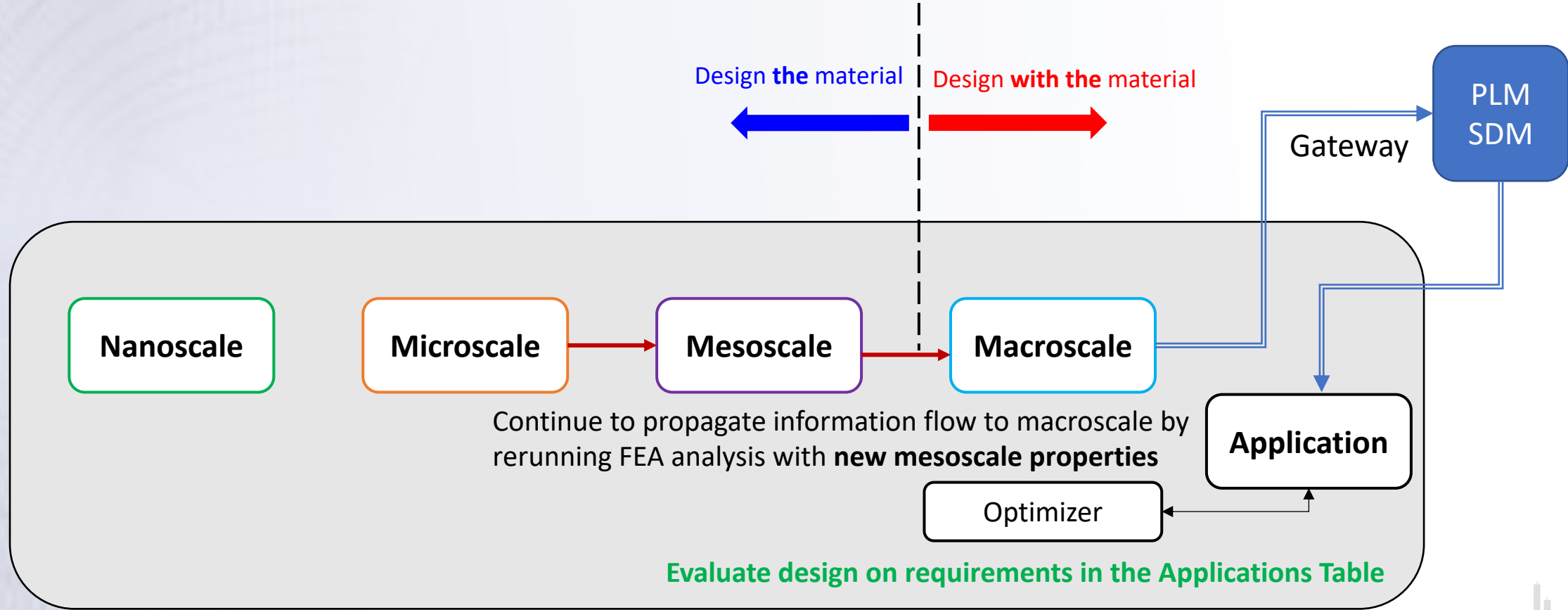

Database/Simulation Management in ICME



Enhancing optimization and design speed by replacing physics-based models with **surrogate models** developed using **machine learning** at **any scale**

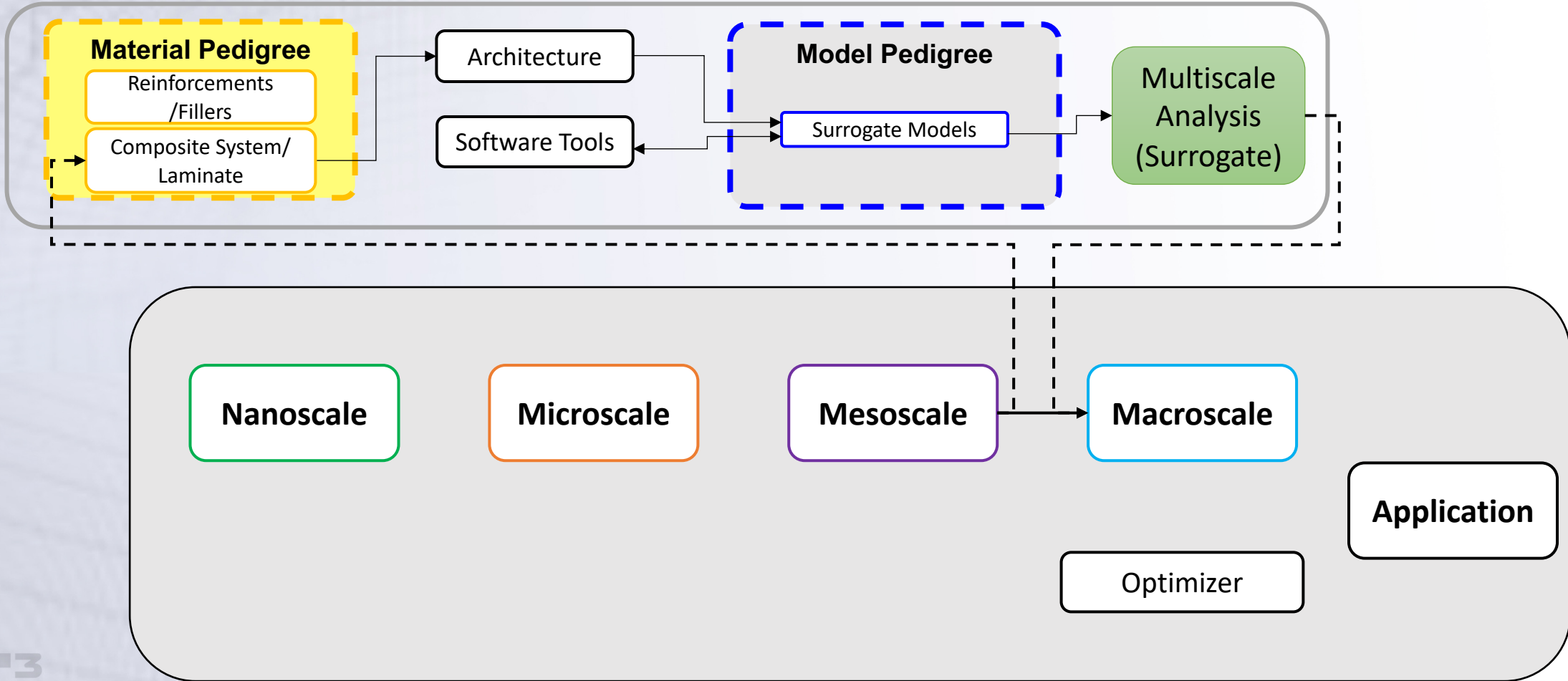

PLM
SDM



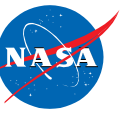

Closing Comments

- Effective Material ***Information Management*** is essential for efficient and cost-effective design of new materials
 - Data management is a critical element of the NASA Vision 2040
- **Granta MI** offers a platform for importing, storing, and disseminating data to the right people, in the right format, at the right scale, and at the right time
 - Commercial database platforms remove the burden from end users of maintaining a database system and allow focus to be placed on schema design and development of auxiliary tools
- NASA GRC has developed a robust schema to handle both real (test) and virtual (simulation) data, physics-based and data driven models, and applications to facilitate capturing and *maintaining institutional knowledge*
- The toolsets developed at NASA GRC interact with the database to enable automatic capture, analysis, maintenance, and dissemination of data to realize 'fit-for-purpose' materials

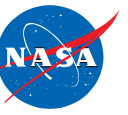

Comments/Issues

- **Informatics is a foundational technology - can't be minimized**
 - Technology (“software”) is often seen as the (easy) choice
 - Process (“language”) is more important, and should be a focus
- People and organization (“culture”) constitute the **biggest challenge** – **MUST DEVELOP DIGITAL CULTURE**
- Data sharing requires that **data can be parsed, understood, and reused by people and applications other than** those that created the data
- Security throughout system is paramount!!
- ***2040 VISION will require the merging of application focused technologies and material focused technology into a seamless toolset.***
- Must realize, solution will most likely **not** be a single toolset/environment or “database” therefore essential to identify/specify requirements for communication.



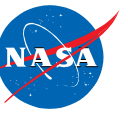

Available Publications

- [NASA TM-20230018337](#) : NASA GRC ICME Schema for Materials Information Management: An Executive Summary
- [NASA TM-20220018403](#) : Application Table: A Bridge Connecting the Designing “With-The-Material” and “The-Material” Paradigms
- [NASA TM-20220017137](#) : A Robust Machine Learning Schema for Developing, Maintaining, and Disseminating Machine Learning Models





Thank You for Your Attention



Integrate Don't Duplicate

Steve Arnold
NASA Glenn Research Center
Multiscale and Multiphysics Modeling Branch
steven.m.arnold@nasa.gov

Brandon Hearley (Digital Transformation Specialist)
NASA Glenn Research Center
Multiscale and Multiphysics Modeling Branch
Brandon.L.Hearley@nasa.gov

