

A photon counting ground receiver for free-space optical communications

Advanced Photon Counting Techniques XVIII

Jennifer N. Downey

NASA Glenn Research Center

Cleveland, Ohio

Notice for Copyrighted Information

This manuscript is a work of the United States Government authored as part of the official duties of employee(s) of the National Aeronautics and Space Administration. No copyright is claimed in the United States under Title 17, U.S. Code. All other rights are reserved by the United States Government. Any publisher accepting this manuscript for publication acknowledges that the United States Government retains a non-exclusive, irrevocable, worldwide license to prepare derivative works, publish, or reproduce the published form of this manuscript, or allow others to do so, for United States government purposes.

Introduction

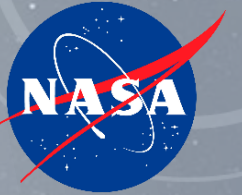

- **NASA Glenn is building a fiber-coupled photon-counting ground receiver compliant with the Consultative Committee for Space Data Systems (CCSDS) Optical Communications High Photon Efficiency (HPE) standard.**
 - PPM: 4, 8, 16, 32, 64, 128, 256
 - Slot widths: 512 ns - 125 ps
 - Maximum data rate: ~2 Gbps
- **CCSDS HPE Modes currently implemented:**
 - PPM: 16-32
 - Code rates: 1/3, 1/2, 2/3
 - Slot widths: 2 ns, 1 ns, 0.5 ns
 - Convolutional channel symbol interleaver with $N=84$, $B = \{0, 540, 2160, 4140\}$
- **Goals:**
 - Utilize commercial off the shelf (COTS) components
 - Demonstrate with Optical Artemis-II Orion (O2O) at the NASA Goddard Low Cost Optical Terminal (LCOT) ground station
 - Release CCSDS HPE VHDL code internationally
 - Enable technology infusion in missions

Receiver for pulse position modulation (PPM)



- **PPM: Power efficient modulation designed for low-photon flux regime, such as deep space**
- **<1 photons per bit received**
- **Direct detection, photon counting receiver**

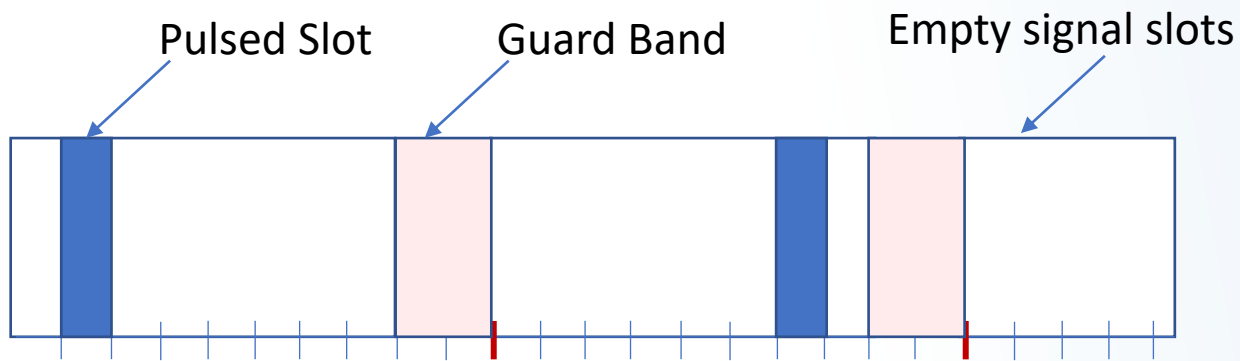

PPM-8: 8 signal slots, 2 guard band slots

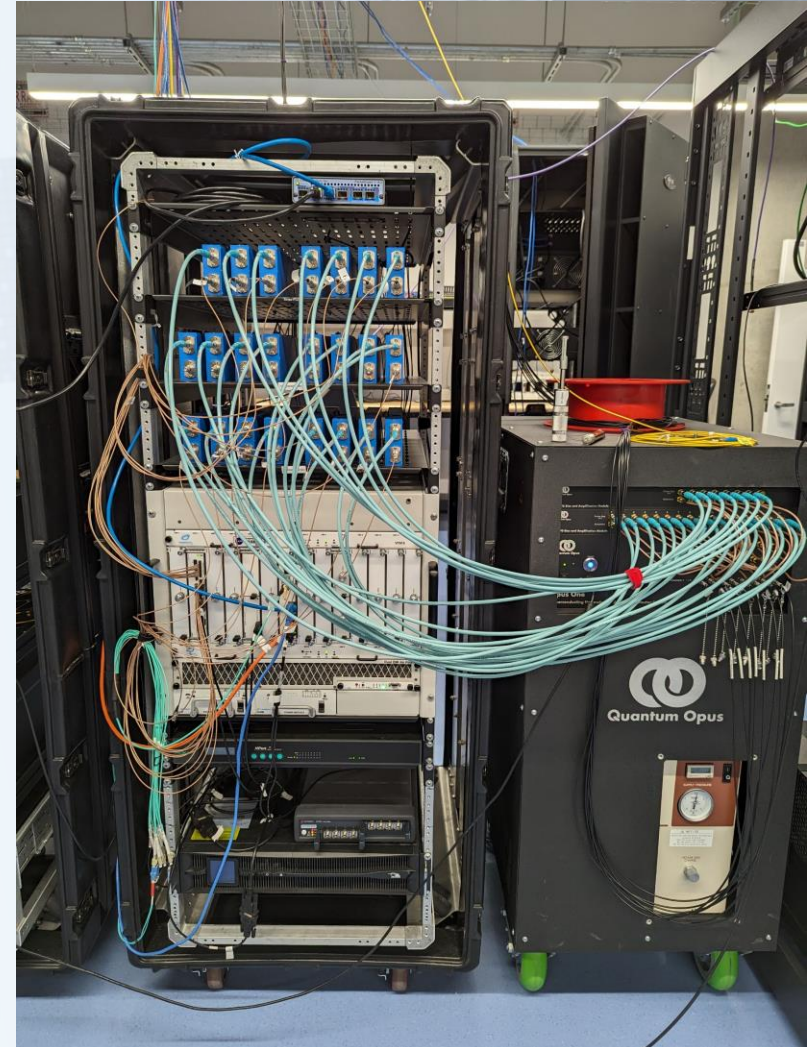

Receiver System

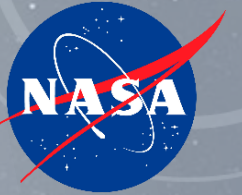

- Fiber Interconnect
- Superconducting nanowire single photon counting detectors (SNSPDs)
- FPGA-based receive modem

Real Time Optical Receiver

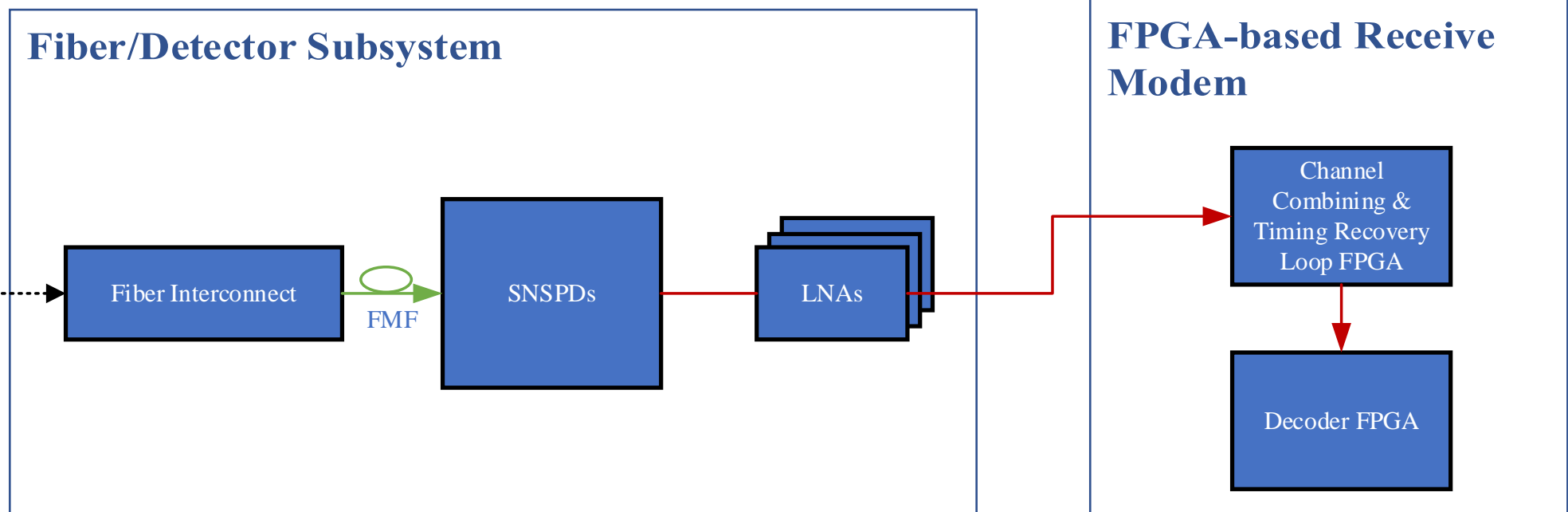

Few Mode Fiber (FMF) and SNSPD Array Architecture

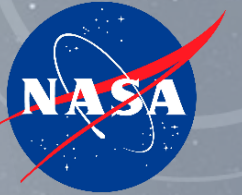

Fiber Interconnect:

- 10-mode, 25 μm , graded index, FMF

Detectors:

- 15-element array
- $1/e$ reset time: 5-8 ns
- $< \sim 80$ M counts per second per channel

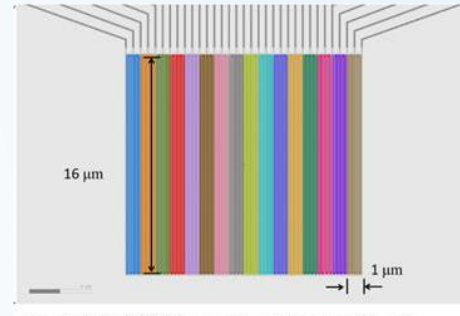

Optical input

Fiber coupler

6LP FMF

20 m

$T = 300$ K

SNSPD array

$T = 2.5$ K

Fiber splice
4LP FMF

50 Ω

50 Ω

50 Ω

50 Ω

50 Ω

50 Ω

1

2

3

15

Output electrical pulses

Photonic Lantern and 7 Single Pixel Architecture



Fiber Interconnect:

- Photonic lantern: 70-mode, 55 μm input core, 25 μm , graded index FMF outputs

Detectors:

- 7 single-pixel
- $1/e$ reset time: 15 ns
- $< \sim 30$ Mcps per channel

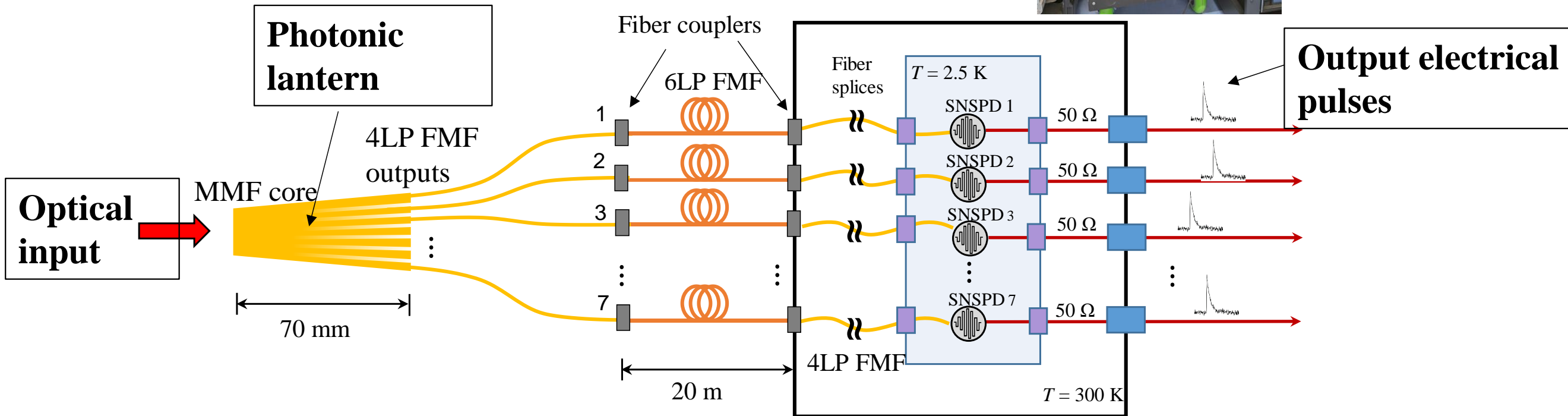
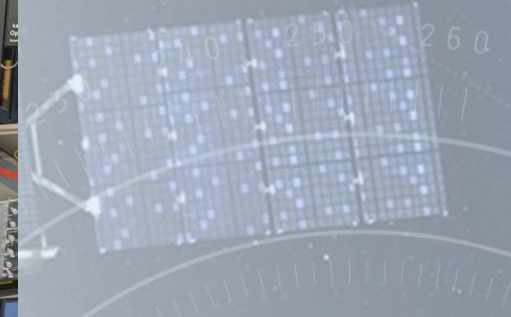
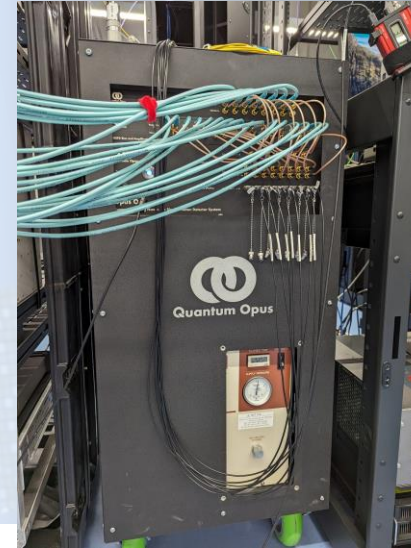

Photonic Lantern



- Number of modes supported matches the sum of the modes supported by the output fibers

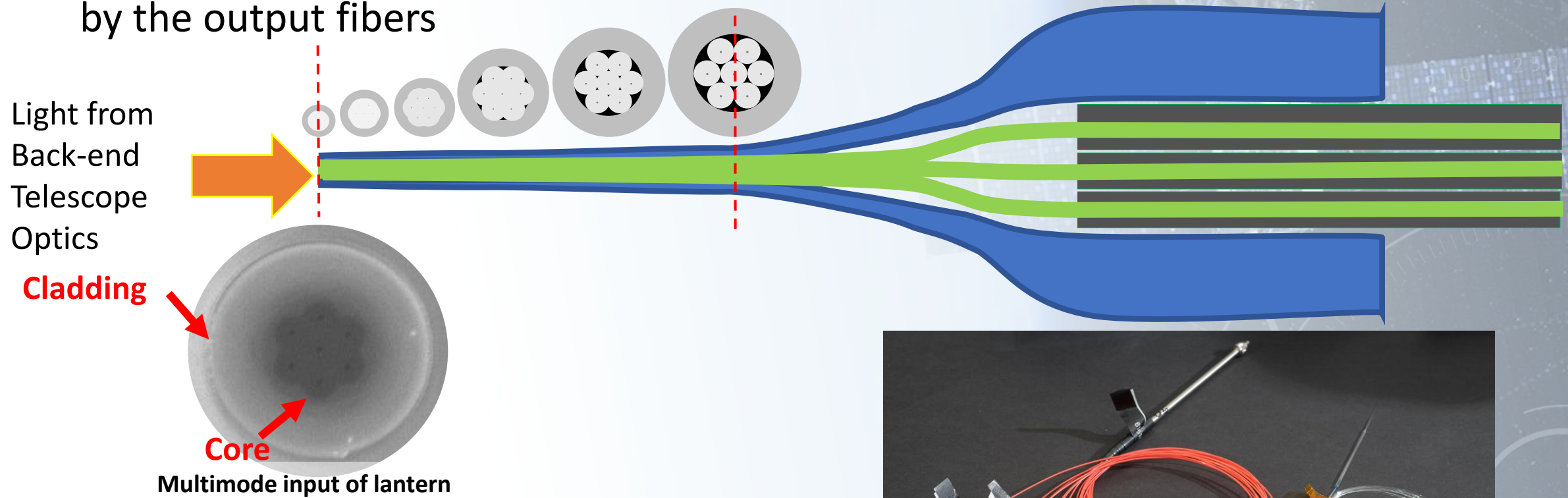

Fully packaged photonic lantern, next to bare photonic lantern

Fiber/Detector Subsystem Architecture Summary



Photon Lantern + 7 Single Pixels

- Input couples 70 spatial modes
- Fiber coupling loss (D/r0 4-9):
 - 4.2 – 6.6 dB
- Number of Detectors: 7
- Detector Reset Time: 15 ns

FMF + 15 Channel Array

- Input couples 10 spatial modes
- Fiber coupling loss (D/r0 4-9):
 - 4.1 – 9.6 dB
- Number of Detectors: 15
- Detector Reset Time: 5-8 ns

FPGA-based Receiver

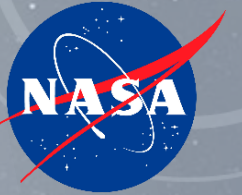

- COTS MicroTCA development platform
- 2 field programmable gate arrays (FPGAs)
- Command/telemetry interface is through HTTP interface built on Space Telecommunications Radio System Architecture



FPGA-based Receiver

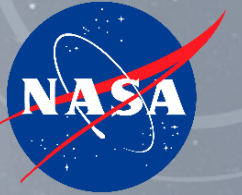

Timing Recovery FPGA

- Symbol timing recovery
- Codeword alignment
- Convolutional deinterleaving

Decoder FPGA

- Iterative decoding
- Derandomization
- Deframing

FPGA-based Receiver: MicroTCA Chassis

Timing Recovery FPGA Card

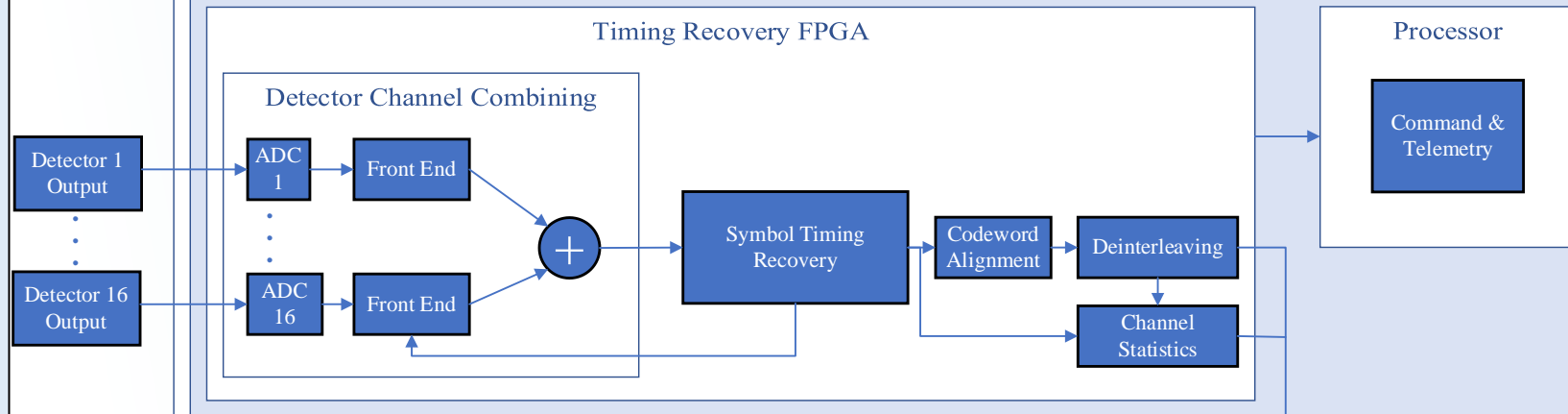

Backplane: High-Speed Serial Link

Decoder FPGA Card

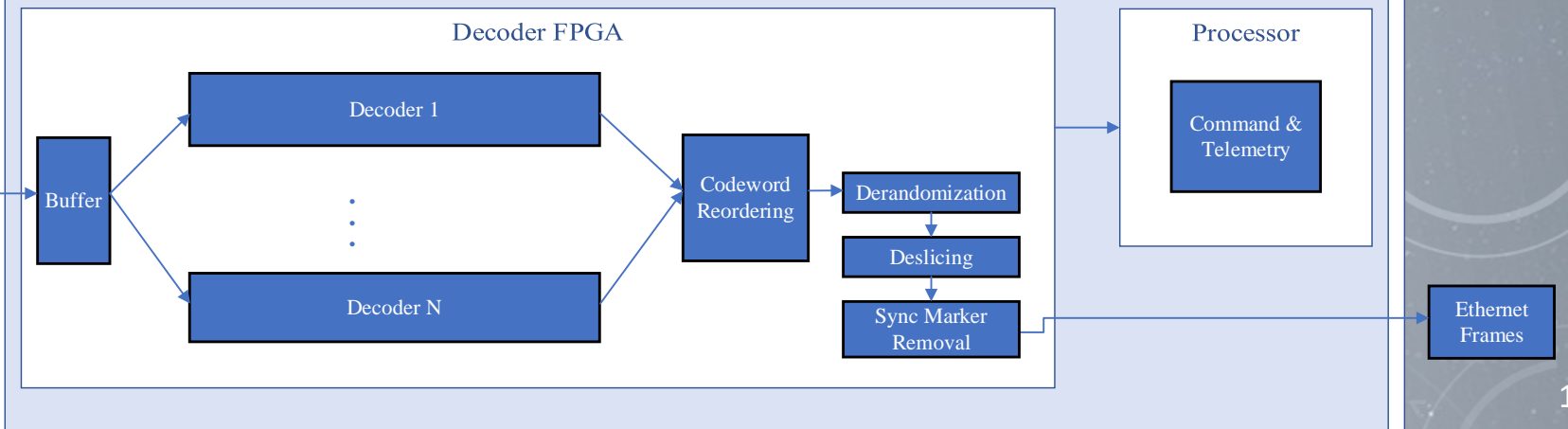

Photon Counting

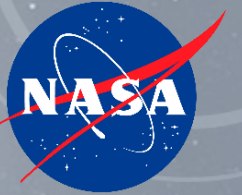

- Performed in the Timing Recovery FPGA
- Xilinx Radio Frequency System on a Chip FPGA (RFSoc)
 - 16 analog to digital convertors (ADCs)
 - Sample rate per channel:
 - > 2 G samples/s
- Count rate per channel:
 - 200 Mega counts per second (Mcps)
- Single FPGA count rate:
 - 3.2 Gcps
- Pulse amplitudes vary, especially at higher count rates, detector pulse walk is caused when using a constant threshold
 - Detection jitter

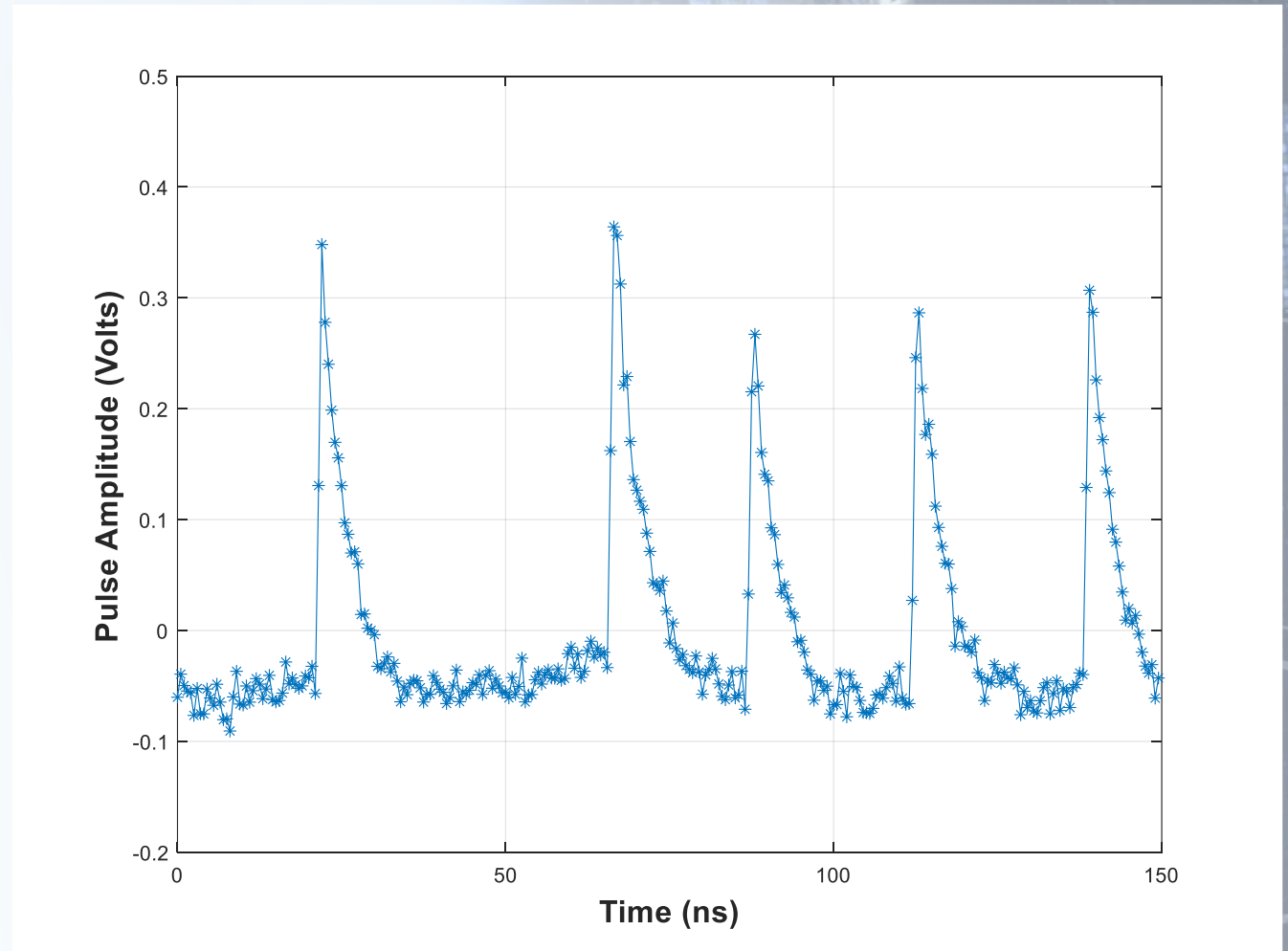

Photon Counting Method



1. A pulse is detected when a sample passes the detection threshold
2. The maximum sample is found from the crossing sample and the next 3 samples
3. The minimum sample is found from the crossing sample and the previous 3 samples
4. The counting threshold is set at 50% of the pulse amplitude
5. The pulse is detected at the first sample to cross the counting threshold

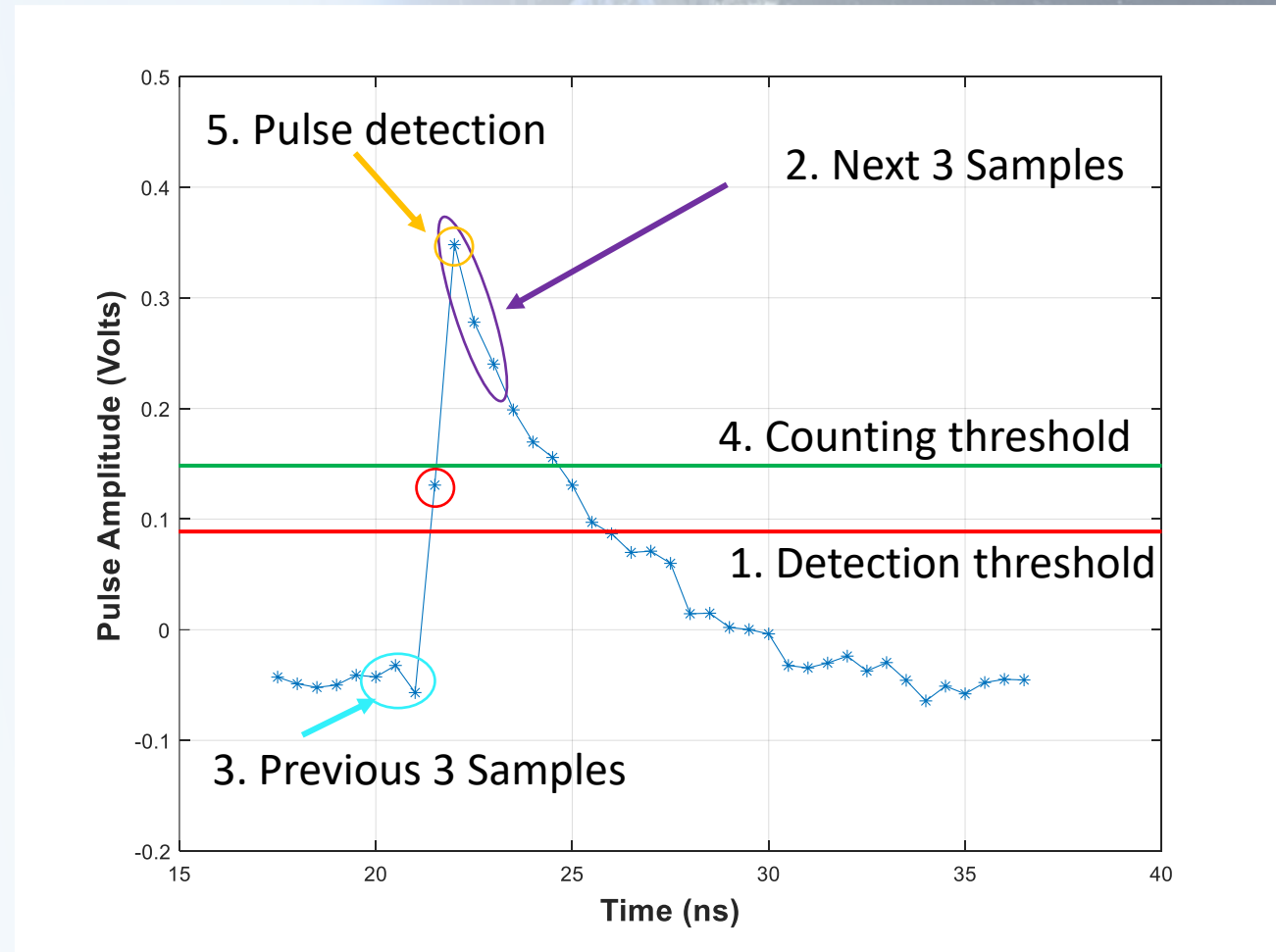

Photon Counting Results

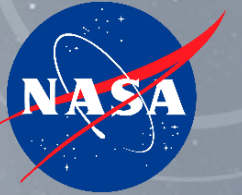

Fixed Threshold

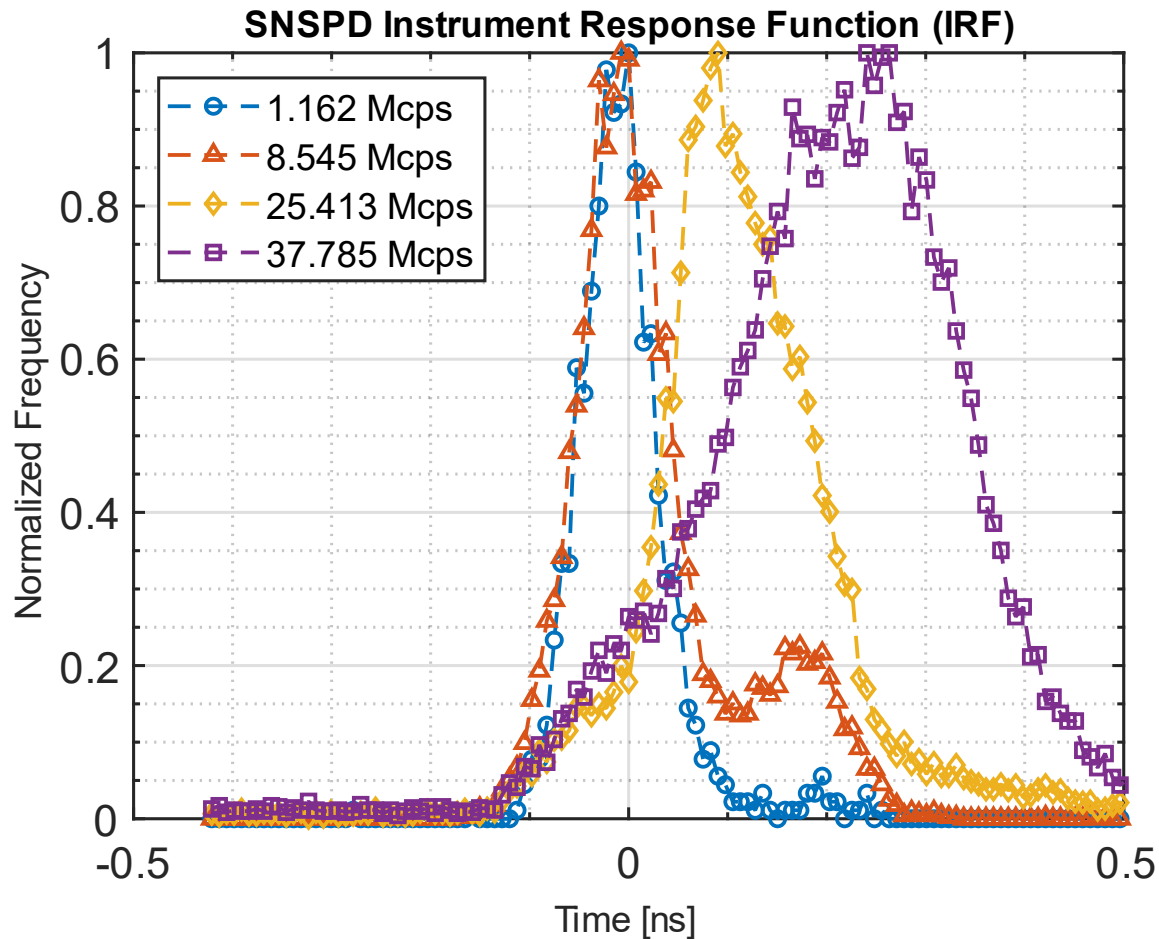

Variable Threshold

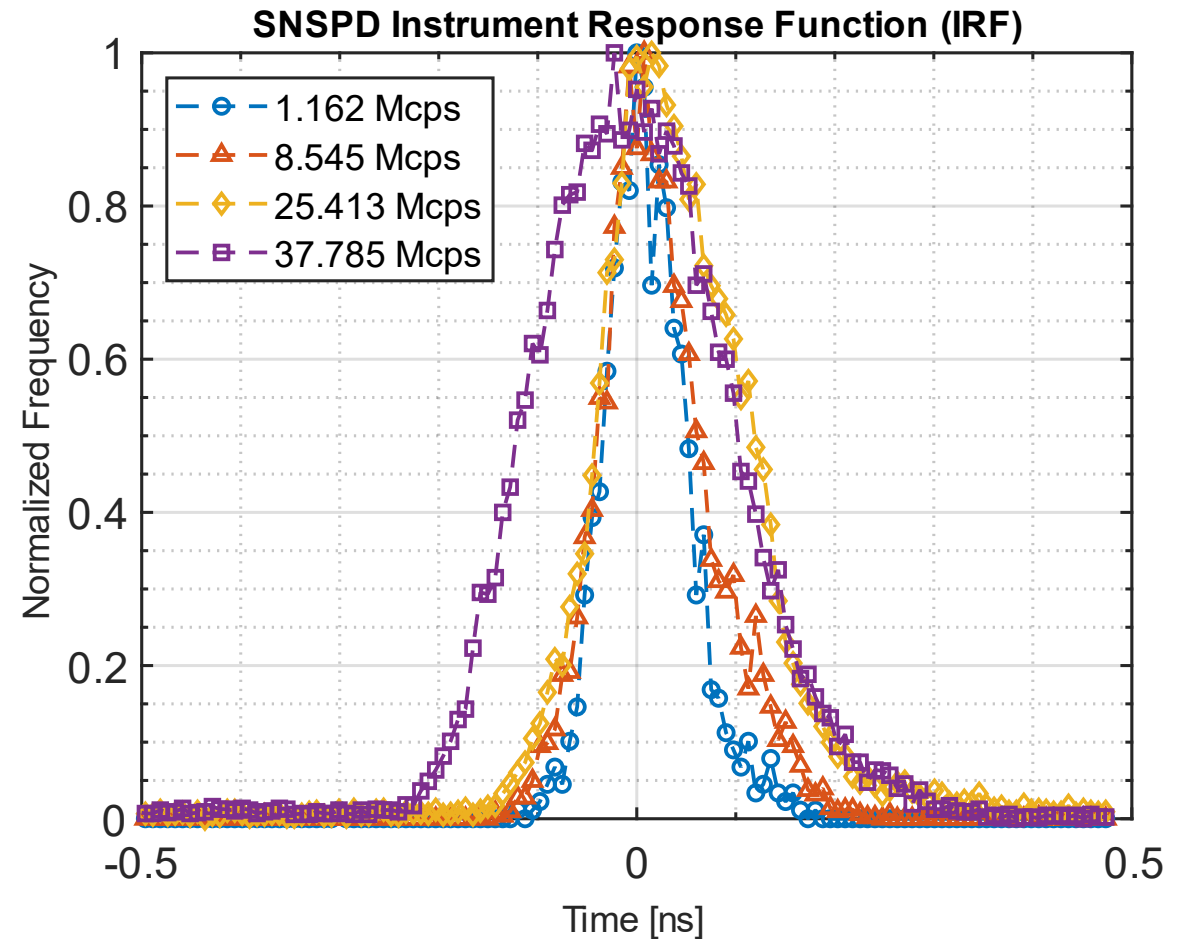

- Measured SNSPD instrument response functions (IRF) at 20 Gbps.
- Input: 70 fs mode-locked fiber laser at 50 MHz repetition rate, attenuated from ~ 0.01 to 1 photon per pulse.

Receiver Results - 7 single pixel detectors

CCSDS Mode: PPM-16, Code Rate 1/3

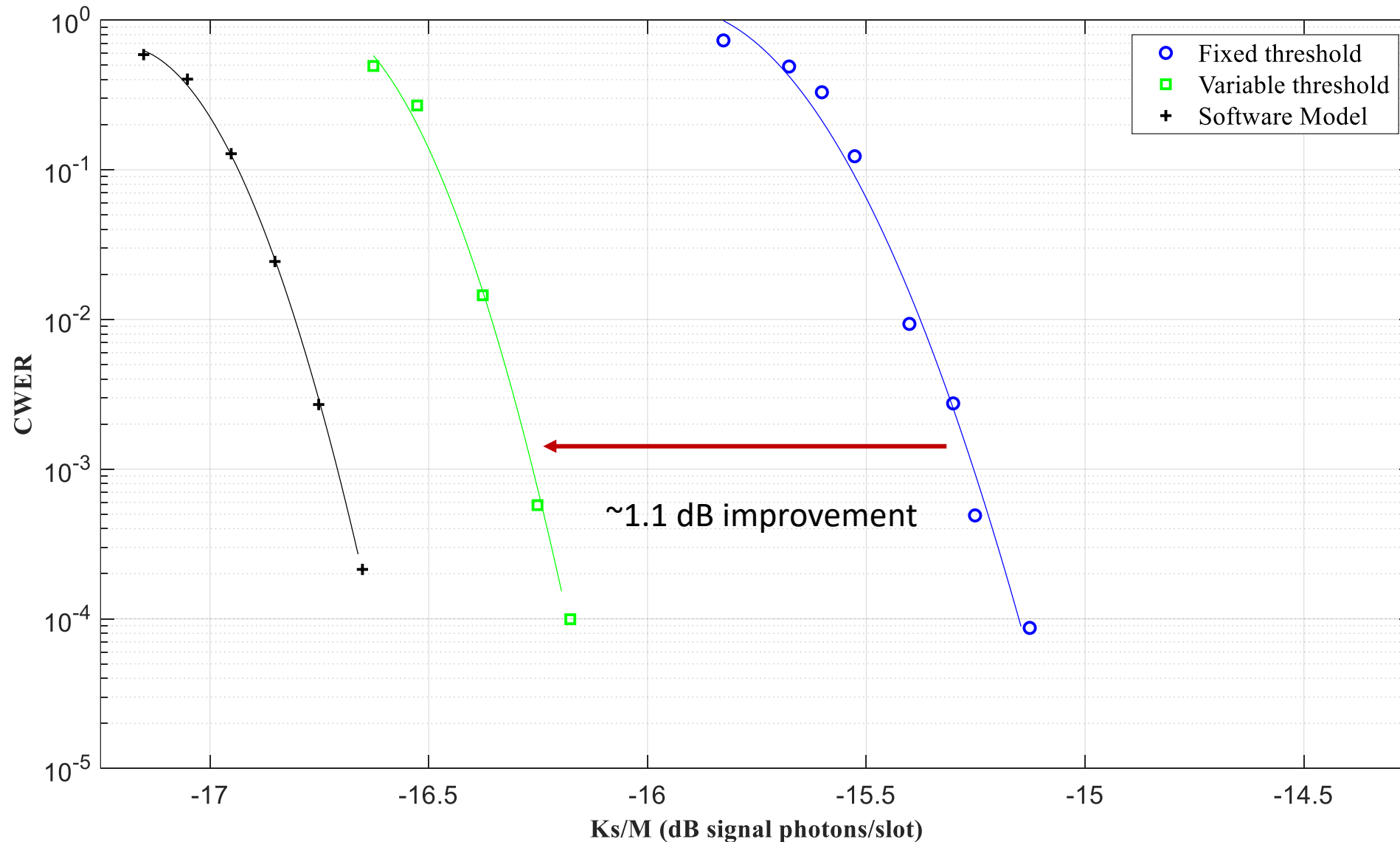
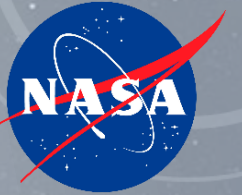

Receiver Baseline Performance Without Fading

PPM-32 Modes

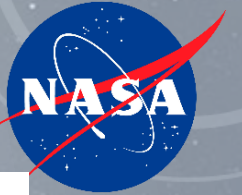

Timing recovery loop acquisition power

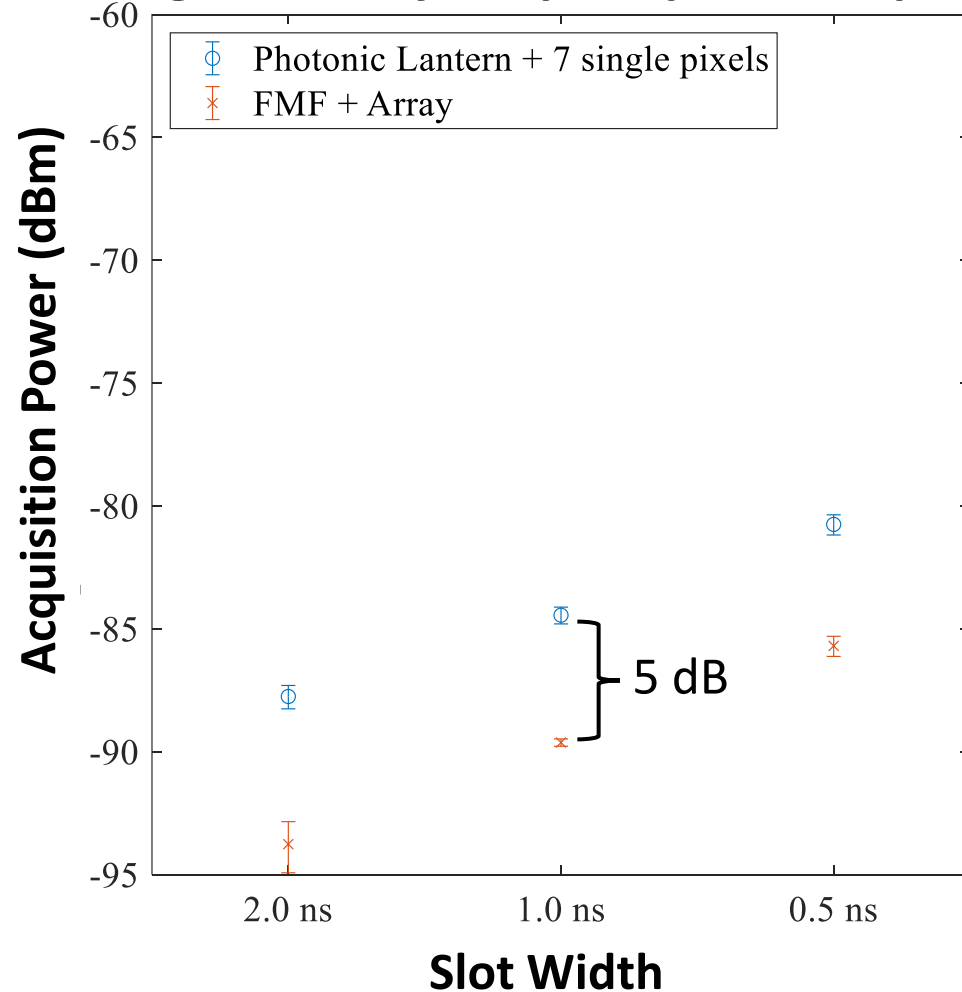

Codeword error rate 10^{-4} power

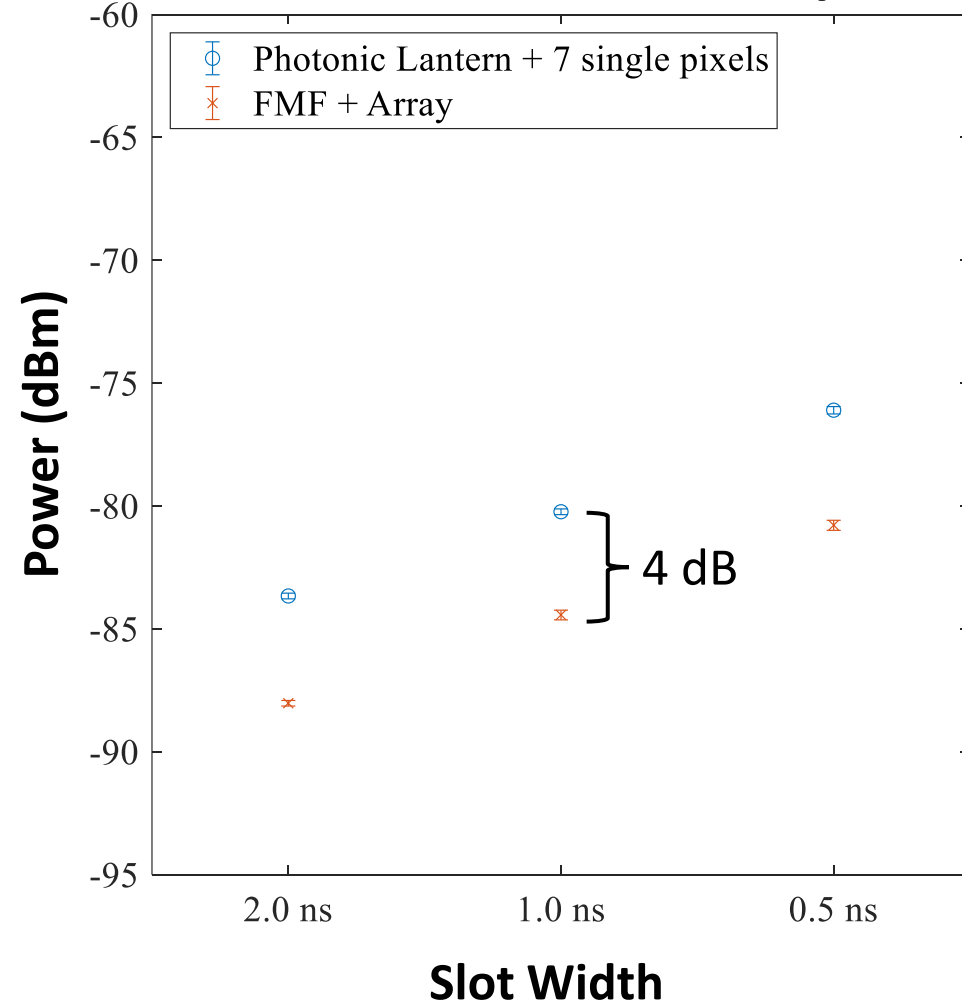

Photonic lantern and 7 single pixel architecture requires 4-5 dB more power.

Receiver Dynamic Range

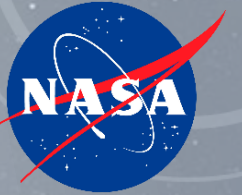

Dynamic range: Ratio between the upper and lower input power limits of the receiver system

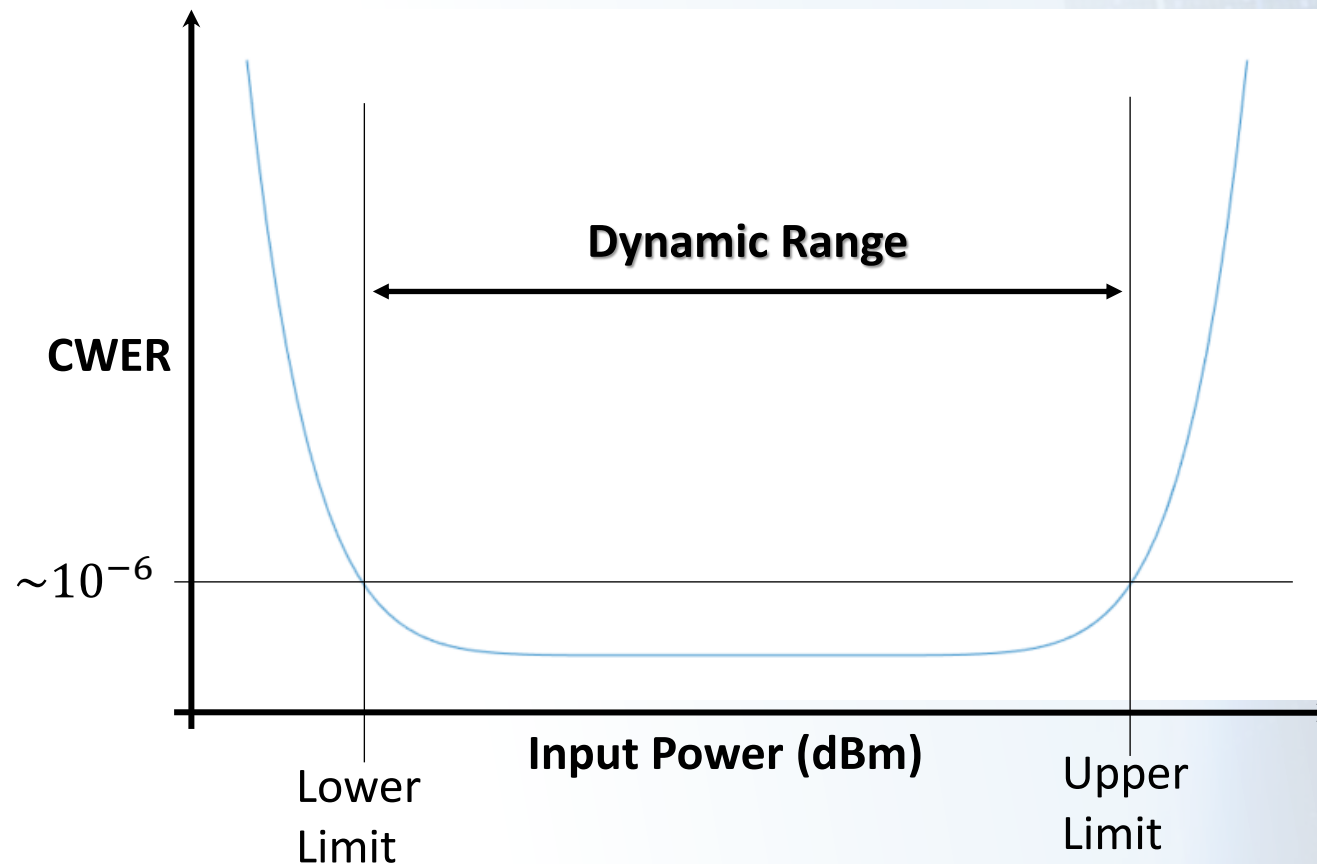

Dynamic Range – Results

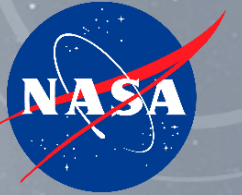

- Lower limit: limited by the performance of forward error-correction code
- Upper limit: limited by poor SNR at higher input photon flux rates and detector reset time

FMF + 15 pixel array

Ts (ns)	PPM	Code Rate	Data Rate (Mbps)	Dynamic Range (dB)
2.0	32	1/3	21	33
1.0	32	1/3	42	28
0.5	32	1/3	83	37
0.5	16	1/3	133	39
0.5	16	1/2	200	33
0.5	16	2/3	267	21

Photonic Lantern + 7 single pixels

Ts (ns)	PPM	Code Rate	Data Rate (Mbps)	Dynamic Range (dB)
2.0	32	1/3	21	29
1.0	32	1/3	42	25
0.5	32	1/3	83	13

Conclusion

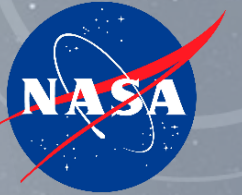

- **Two architectures for a fiber-coupled photon-counting ground receiver have been developed.**
- **FMF + 15-channel array has a 4-5 dB advantage in PPM-32 modes without fades.**
 - **2x detectors each with 1/2 reset time**
- **Architectures perform similar when including fiber coupling loss.**

Receiver will be demonstrated at the NASA GSFC Low Cost Optical Terminal

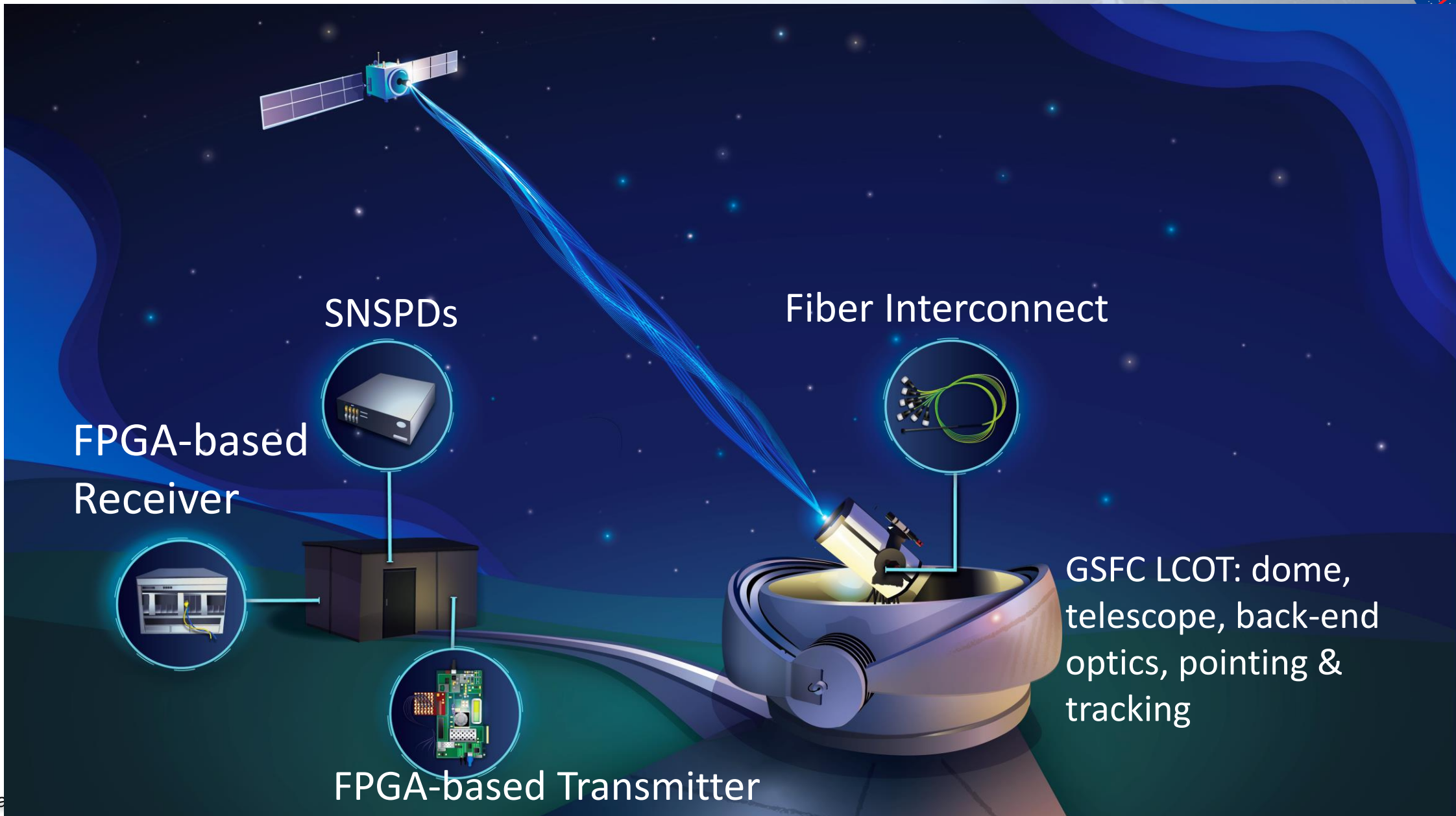
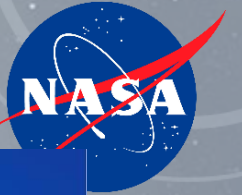

Future Work

Combined Architecture

- Currently working on an architecture which uses both detector systems
- Challenges:
 - Array detectors and single pixel detectors have different ranges of operation
- Advantages:
 - Lower coupling loss with photonic lantern
 - Increased speed from arrayed detectors

Fade Testing

- Utilizing a spatial light modulator and an acoustic optic modulator in real time to emulate fades:
 - Pointing
 - Scintillation
 - Fiber coupling

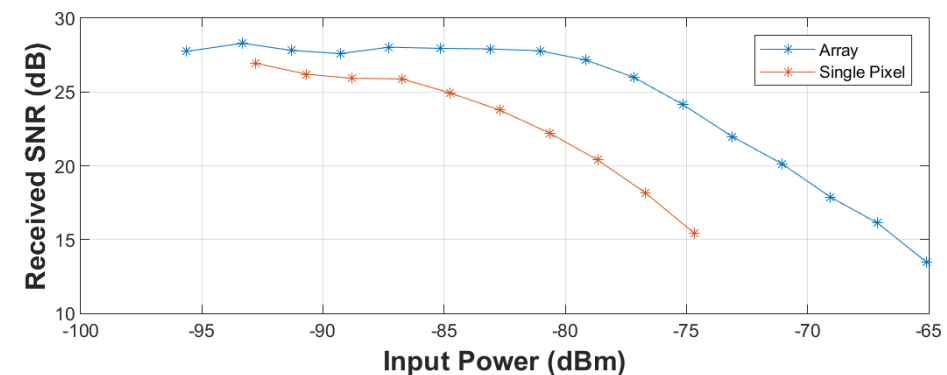
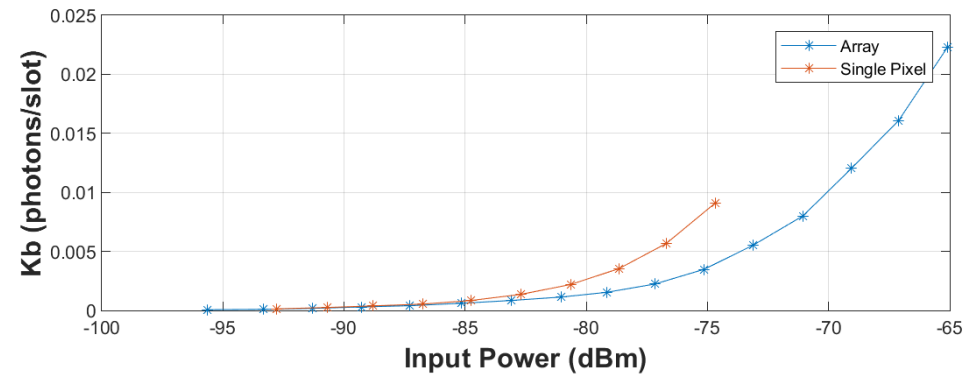
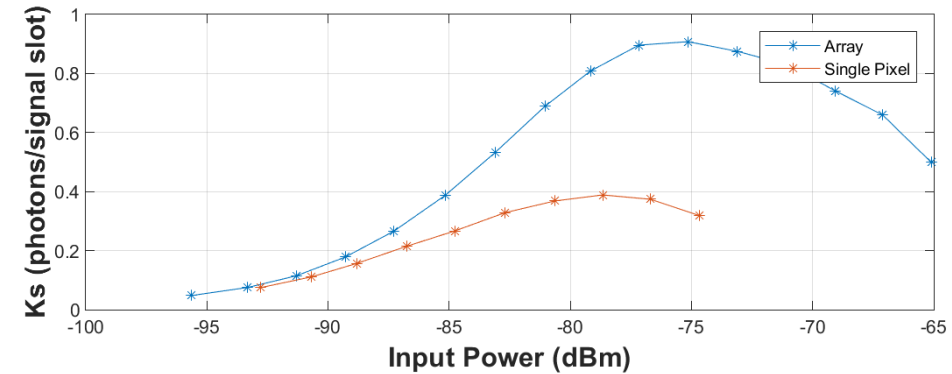
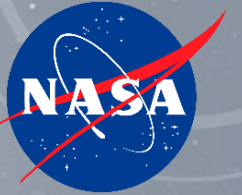



Thank You!

www.nasa.gov/SCaN