



# **Nodal Modeling of Liquid Propellant Feed and Pressurization System**

By

Alok Majumdar and Andre LeClair  
NASA/Marshall Space Flight Center  
Huntsville, AL 35801

**JANNAF 14<sup>th</sup> Liquid Propulsion (LPS) ; 71<sup>st</sup> Propulsion Meeting**  
**May 6-9, 2024**

**Session: (2P Part 2) Propellant Tank Systems Design Analysis and Testing**



## Introduction

- It is possible and practical to use nodal modeling tool to simulate several processes of Liquid Propellant Feed and Pressurization System for preliminary design study.
- 3D Navier Stokes codes are capable of providing accurate and detailed flow characteristics but are not practical to run for preliminary design studies.
- Nodal code discretizes the flow domain into nodes and branches where mass and energy conservation equations are solved at nodes to calculate pressure and temperature and momentum conservation equations are solved at branches to calculate the flowrate.
- This paper describes several applications of Liquid Propellant Feed and Pressurization System using Generalized Fluid System Simulation Program (GFSSP). The applications include: 1. Tank Pressurization, 2. Chillover of Cryogenic Transfer Line, and 3. No Vent Filling of Cryogenic Tank.



# Introduction to GFSSP

## Flow Network Definition

Momentum Conservation Equations are solved at branches

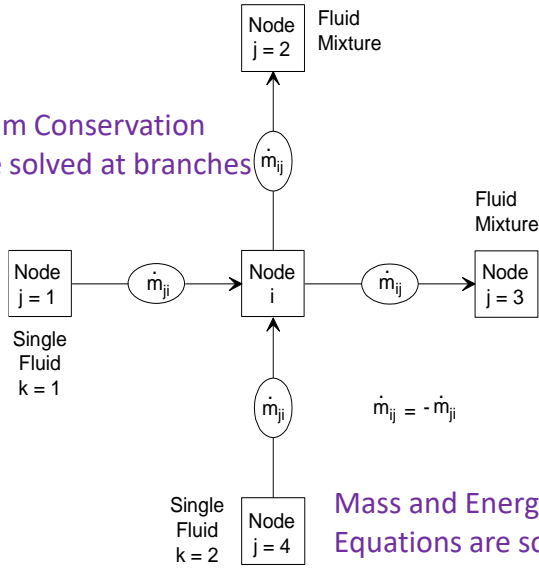

Mass and Energy Conservation Equations are solved at nodes

## Example

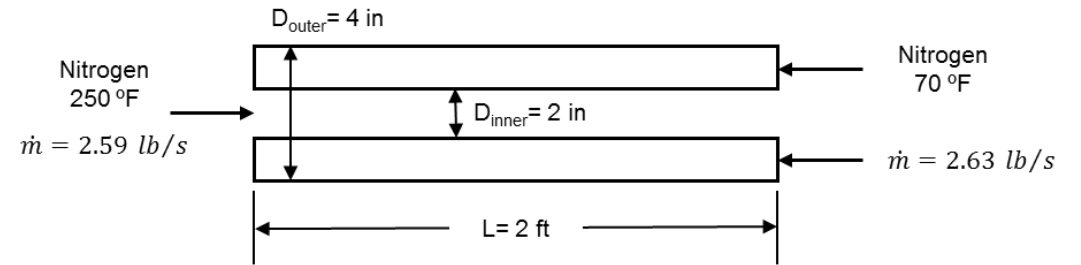

## Program Structure

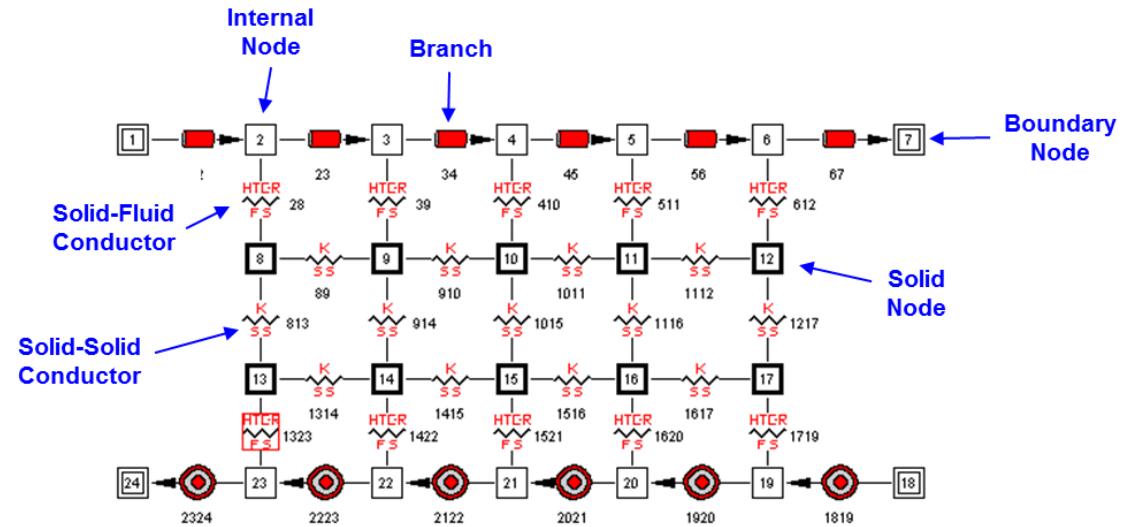
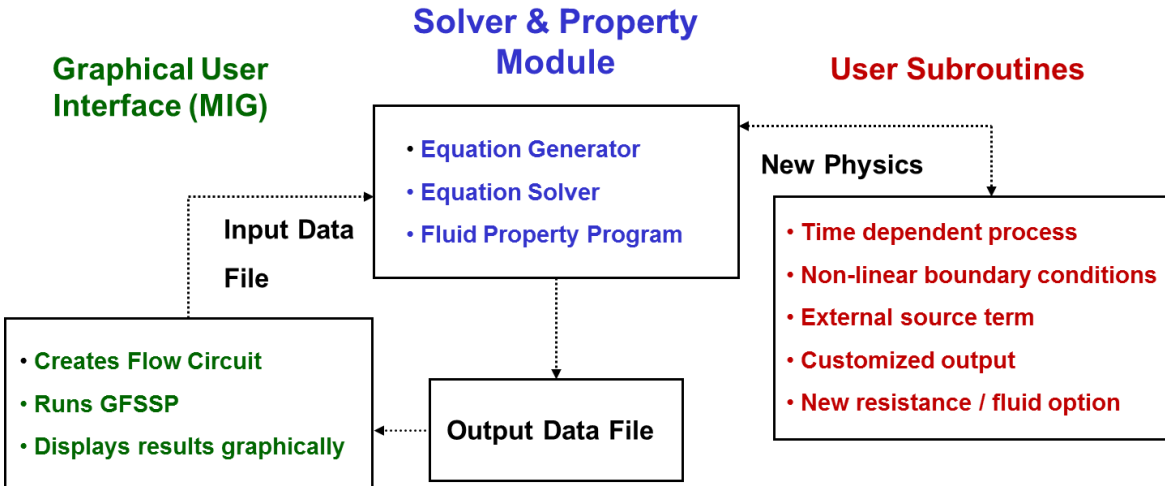



# Tank Pressurization (1/2)

Schematic and GFSSP model of propellant tank pressurization system

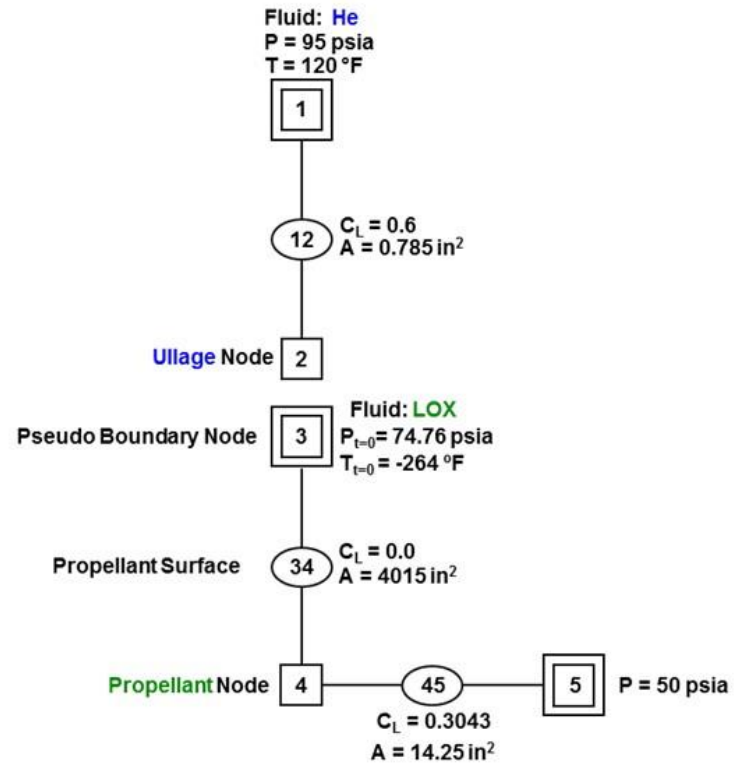
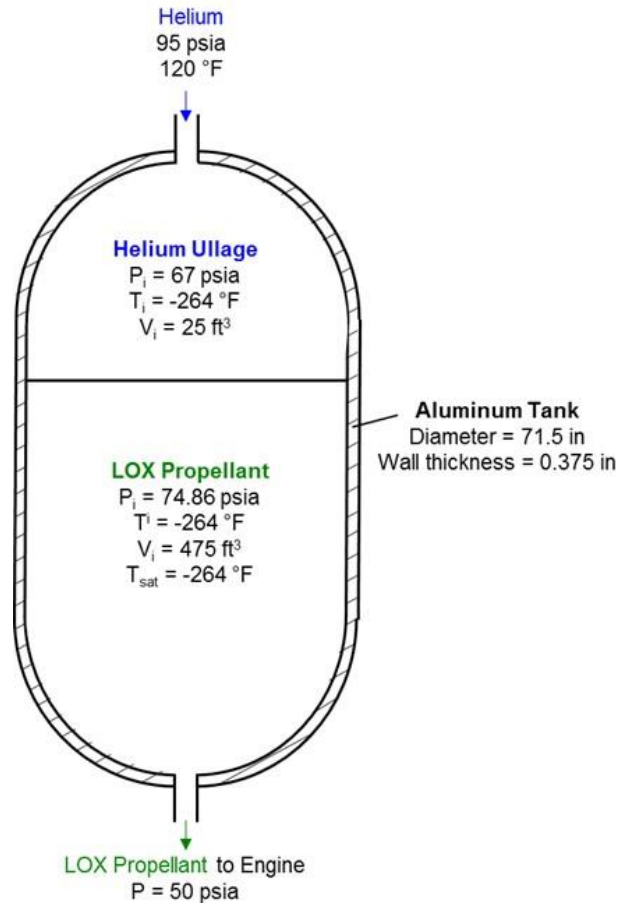

Helium pressurization system of Propulsion Test Article at Stennis Space Center

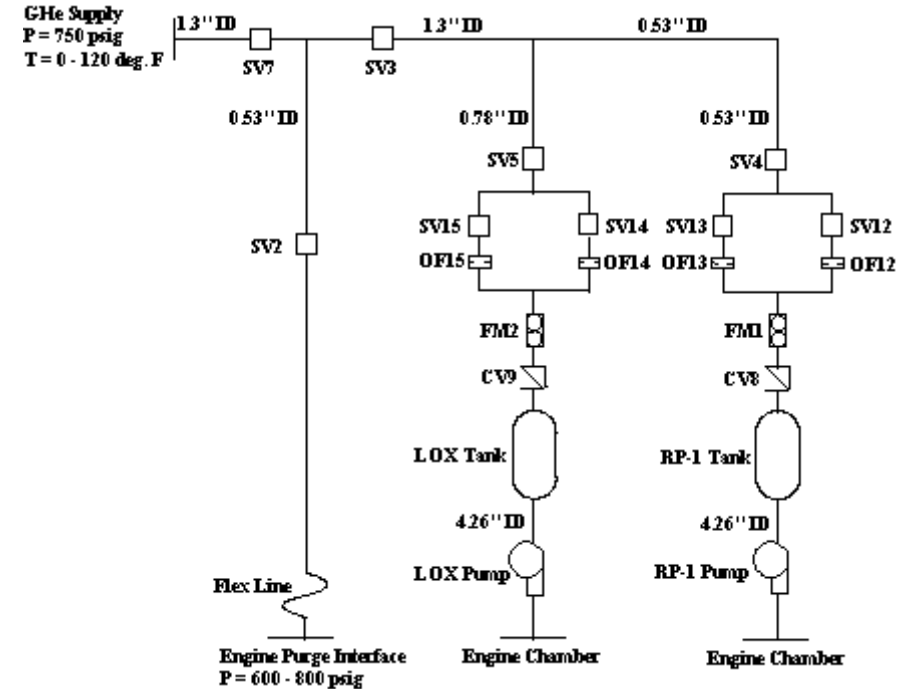



# Tank Pressurization (2/2)

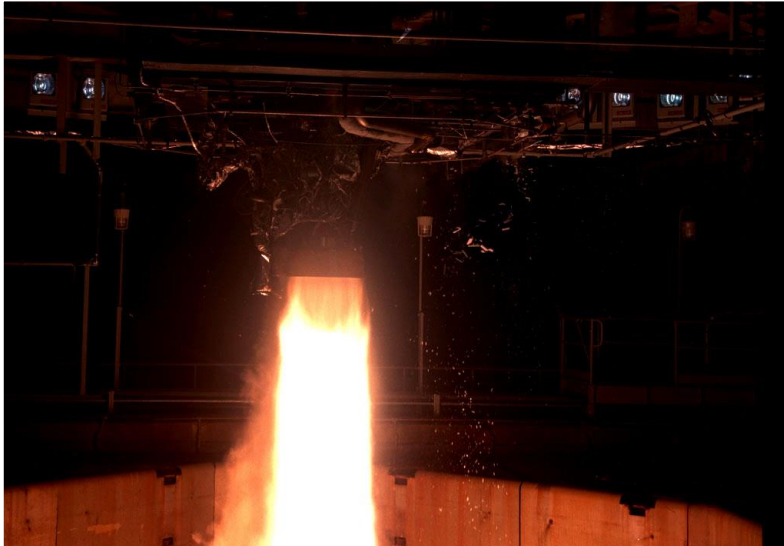

LOX Tank

RP-1 Tank

Engine Interface

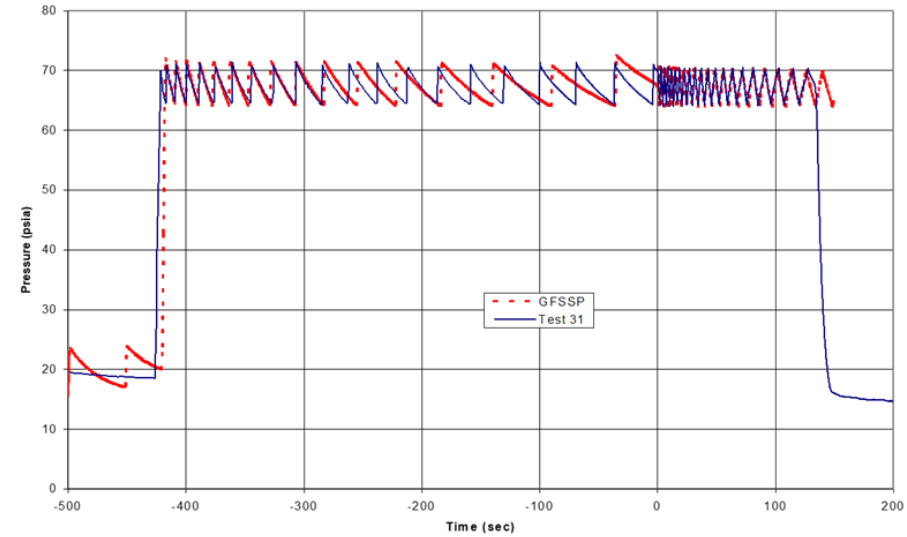



# Self Pressurization Test in Multi-purpose Hydrogen Test Bed (MHTB)

## Thermodynamic Vent System

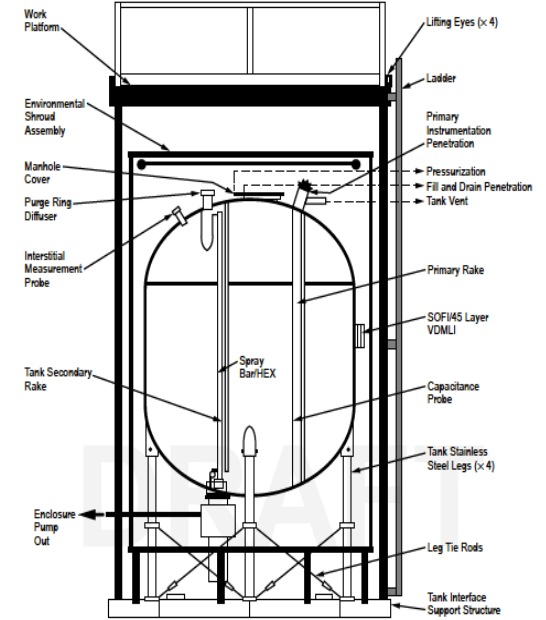
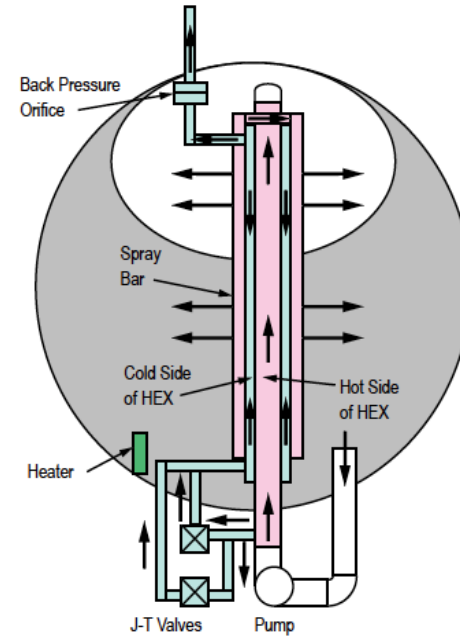

## Multi-Layer Insulation

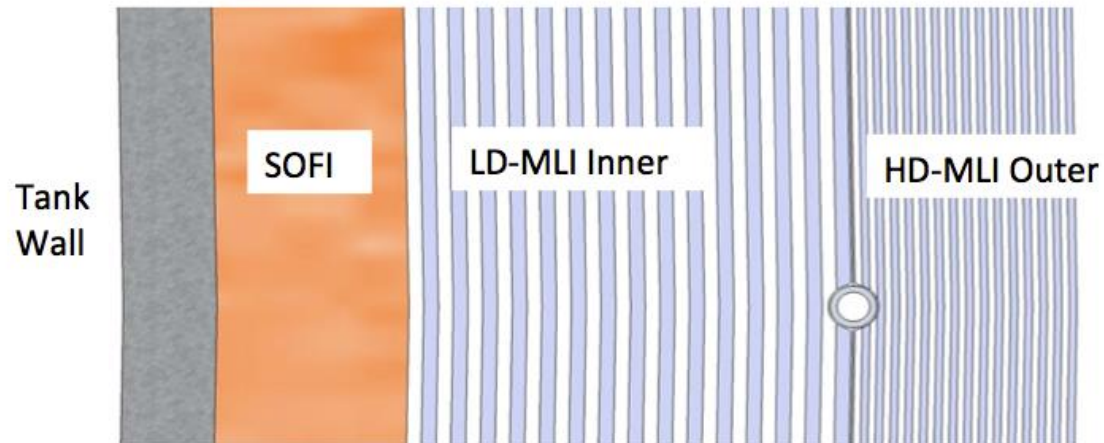



# GFSSP Model and Comparison with Test data for Self Pressurization Test

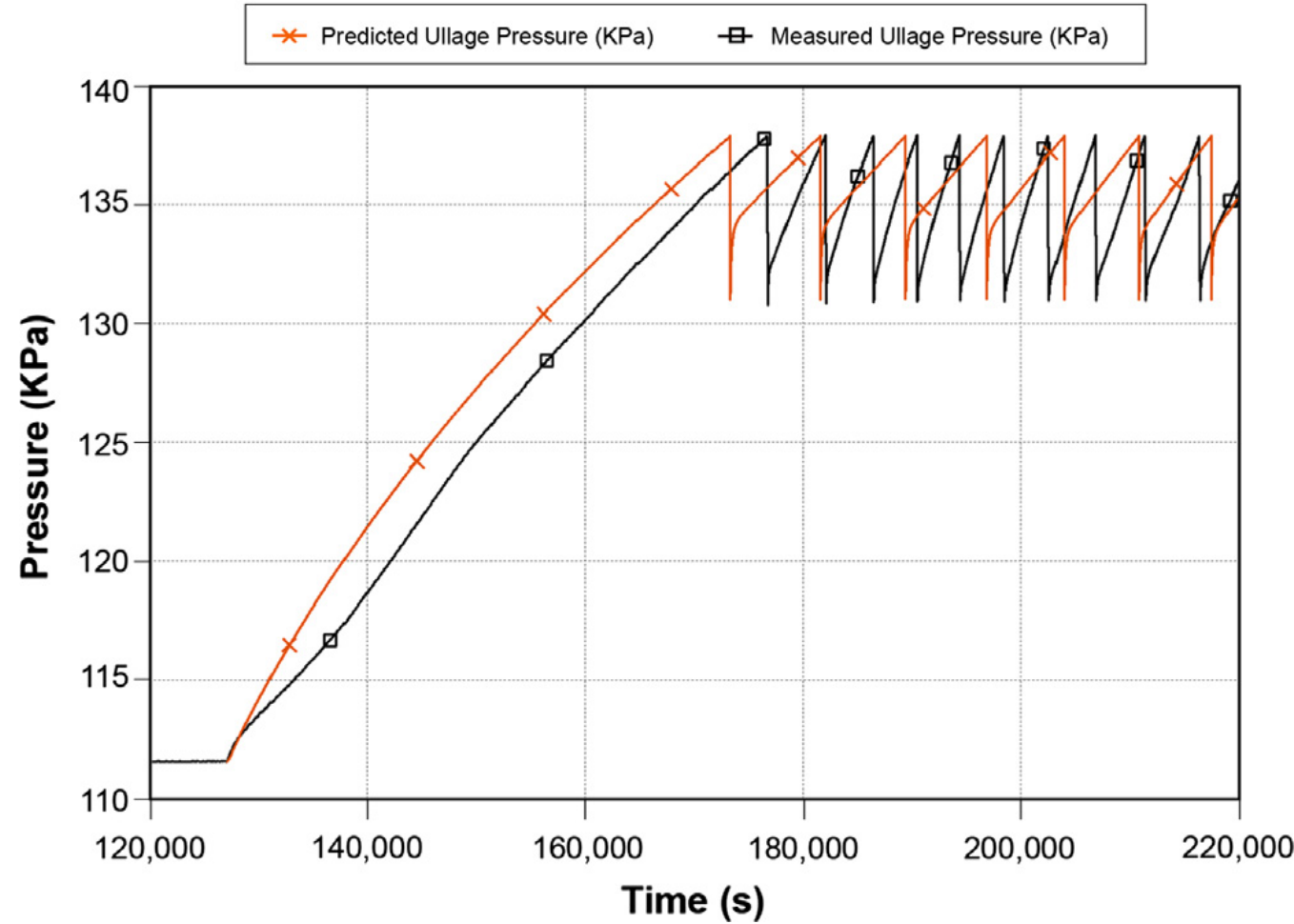
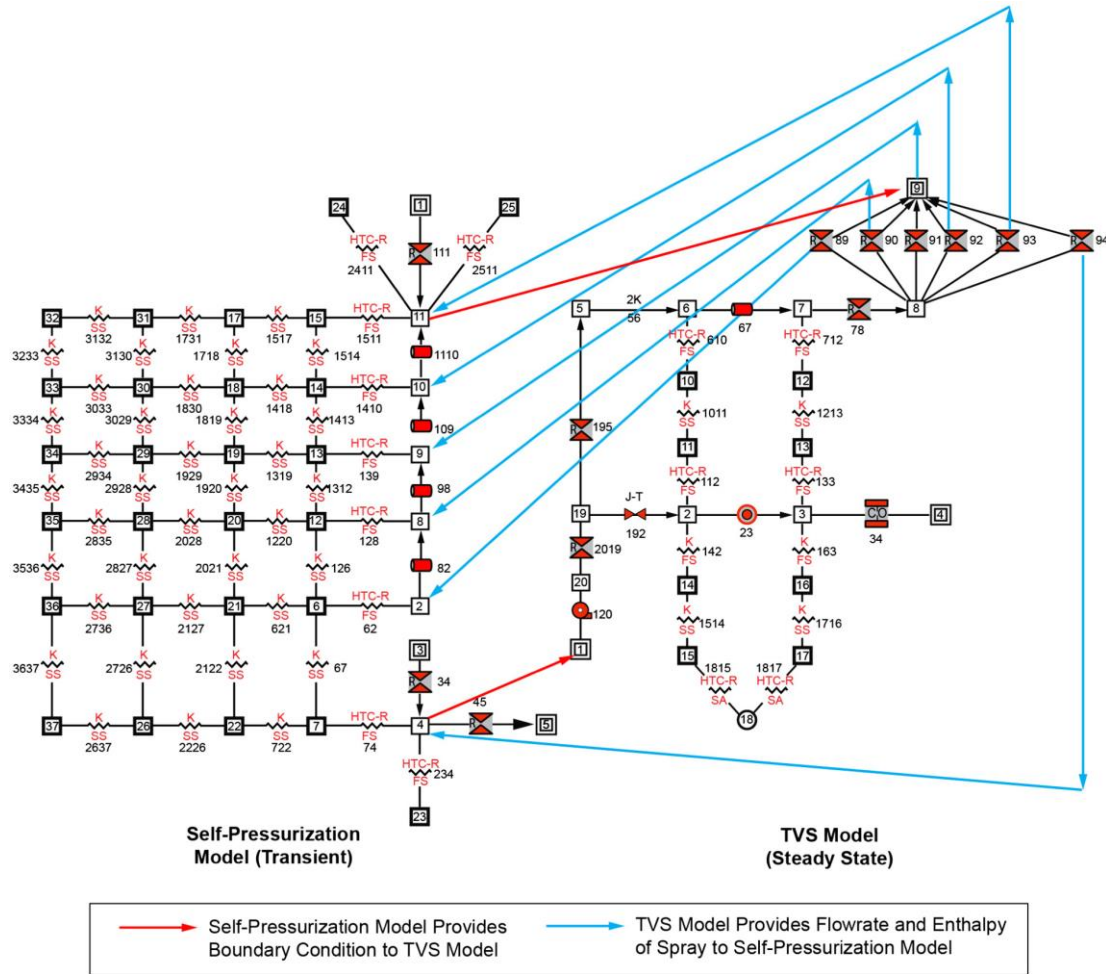



# Chiltdown of Cryogenic Transfer Line

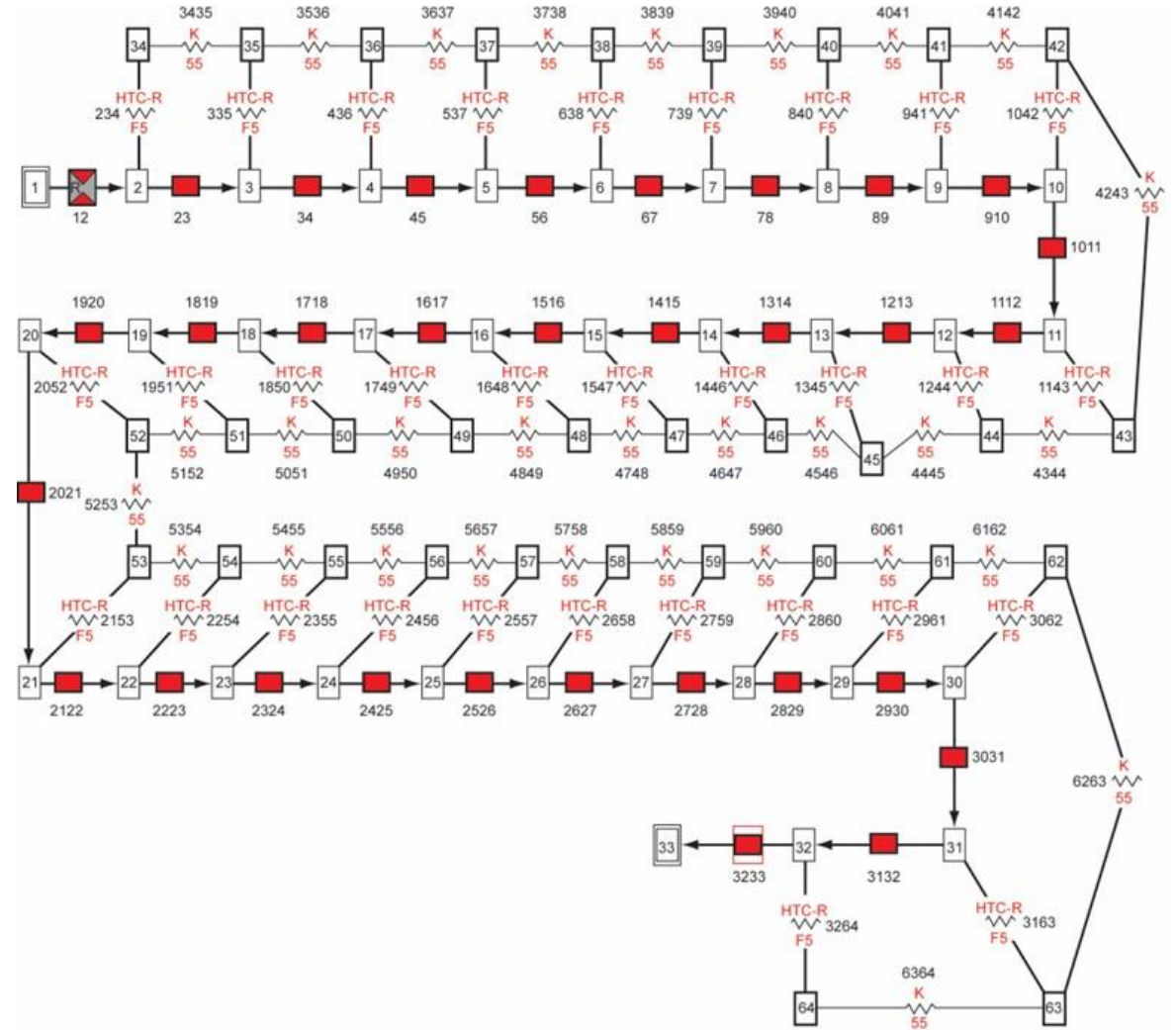
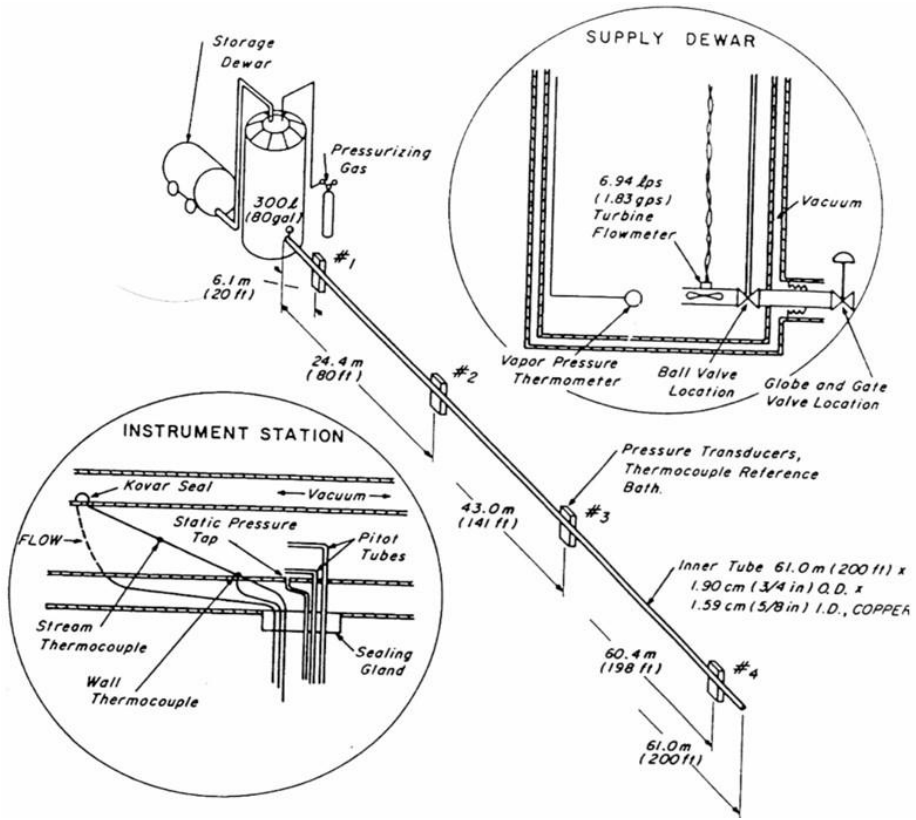





# GFSSP Model Prediction Compared with Test data for Transfer Line Chilldown

## NBS Experiment (Long Tube)

Saturated LH<sub>2</sub> chilldown time for various driving pressures

Driving Pressure (psia)	Saturation Temperature (°F)	Experimental Chilldown Time (s)	Predicted Chilldown Time (s)
74.97	-411.06	68	70
86.73	-409.08	62	69
111.72	-406.4	42	50
161.72	-402.13	30	33

Subcooled LH<sub>2</sub> chilldown time for various driving pressures. LH<sub>2</sub> is subcooled at -424.57 °F

Driving Pressure (psia)	Experimental Chilldown Time (s)	Predicted Chilldown Time (s)
36.75	148	150
61.74	75	80
86.73	62	60
111.72	41	45
136.72	32	35
161.7	28	30

Saturated LN<sub>2</sub> chilldown time for various driving pressures

Driving Pressure (psia)	Saturation Temperature (°F)	Experimental Chilldown Time (s)	Predicted Chilldown Time (s)
61.74	-294.09	165	185
74.97	-289.71	150	160
86.73	-286.24	130	140

Subcooled LN<sub>2</sub> chilldown time for various driving pressures. LN<sub>2</sub> is subcooled at -322.87 °F

Driving Pressure (psia)	Experimental Chilldown Time (s)	Predicted Chilldown Time (s)
36.75	222	250
49.97	170	175
61.74	129	140
74.97	100	100
86.73	85	90

## University of Florida Experiment (Short Tube)

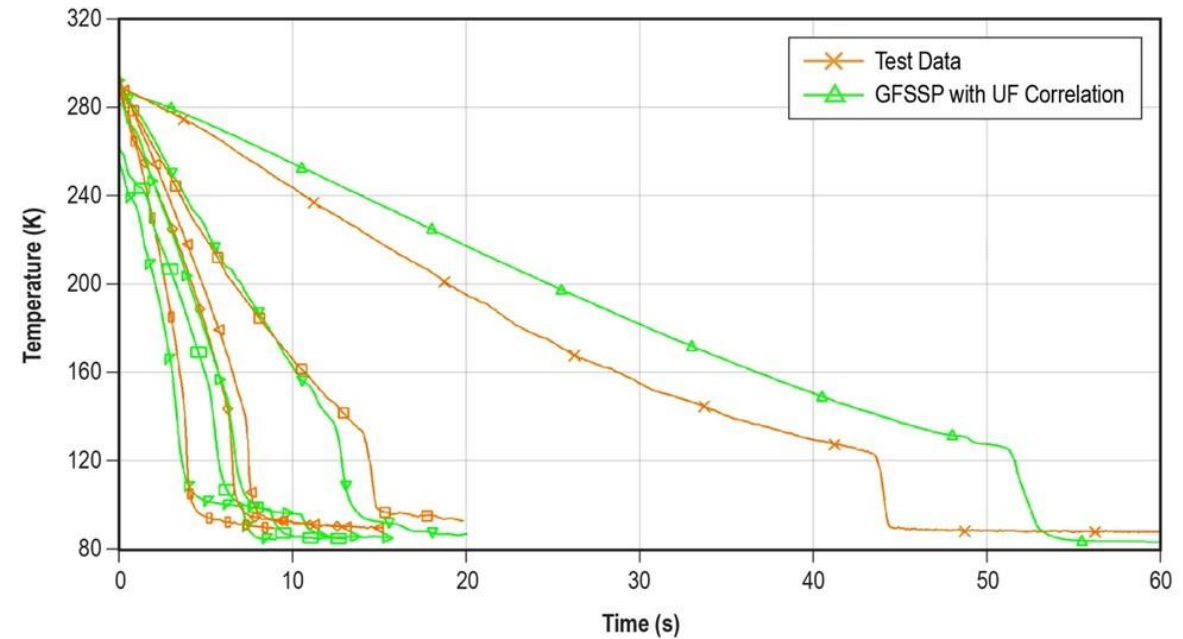



# Vented Chill and No Vent Fill (VCNVF) Experiment at and GFSSP Model

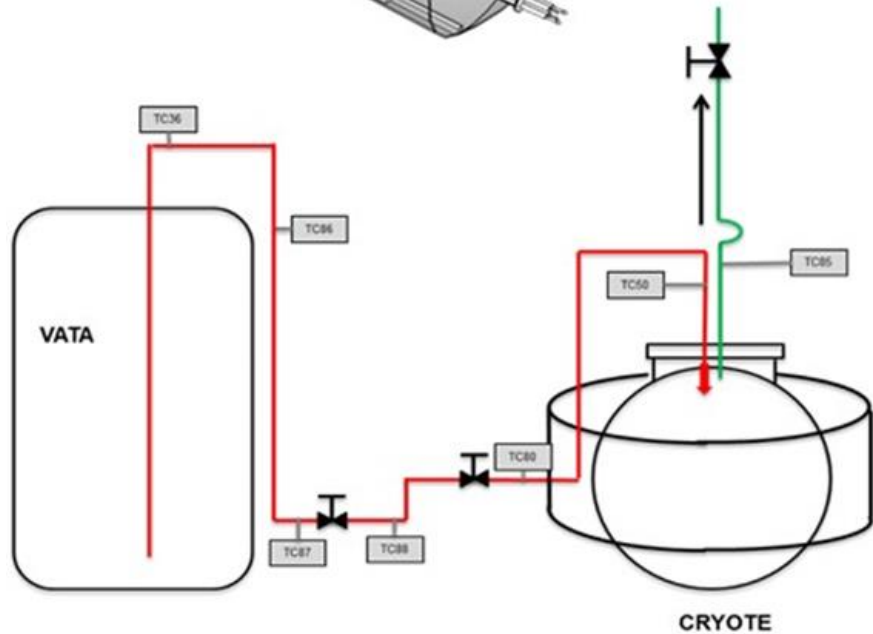
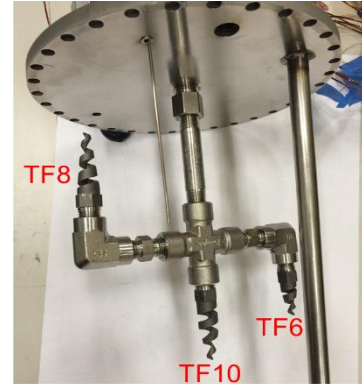
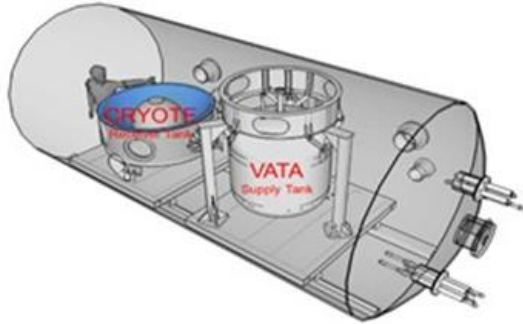

Main Model

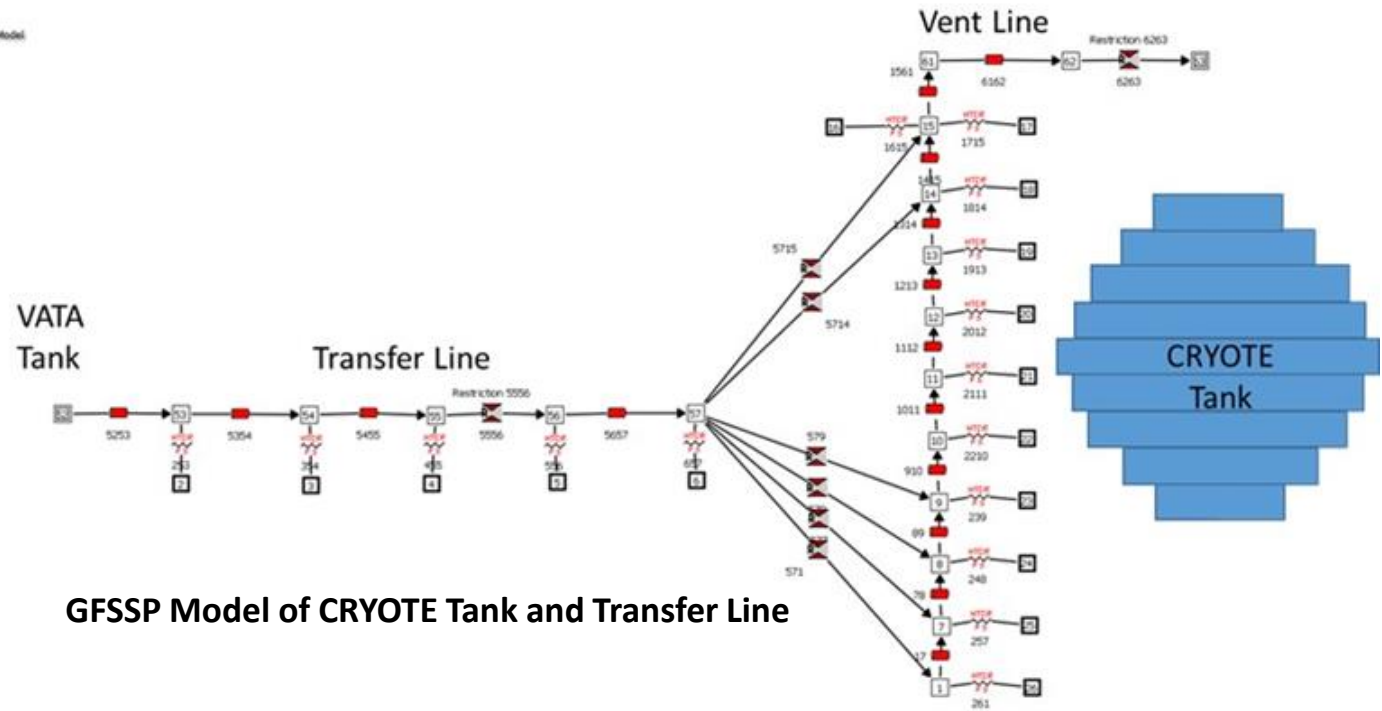

VCNVF Experiment at NASA/MSFC

GFSSP Model of CRYOTE Tank and Transfer Line



# Comparison of Numerical Predictions with VCNVF Test Data

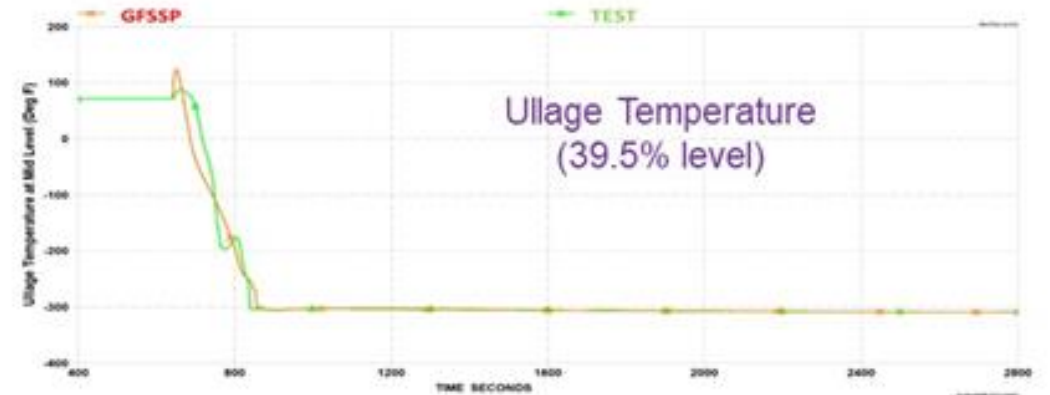
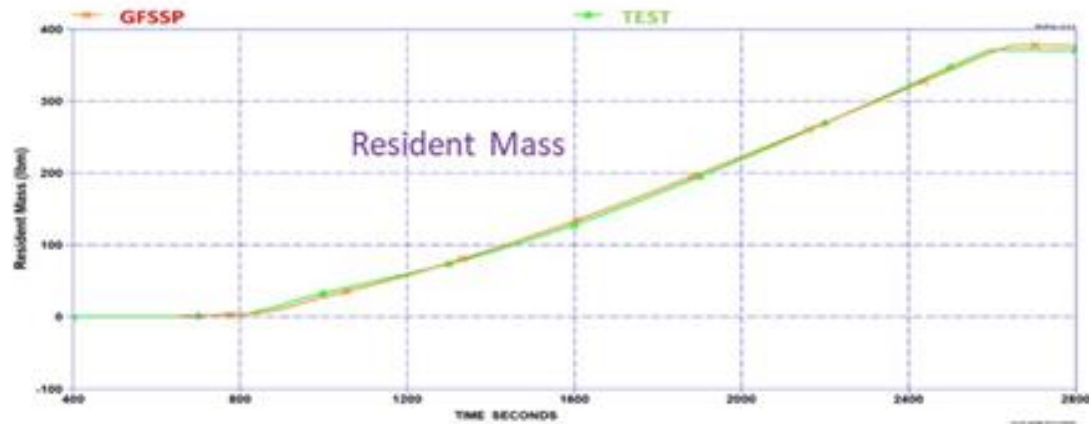
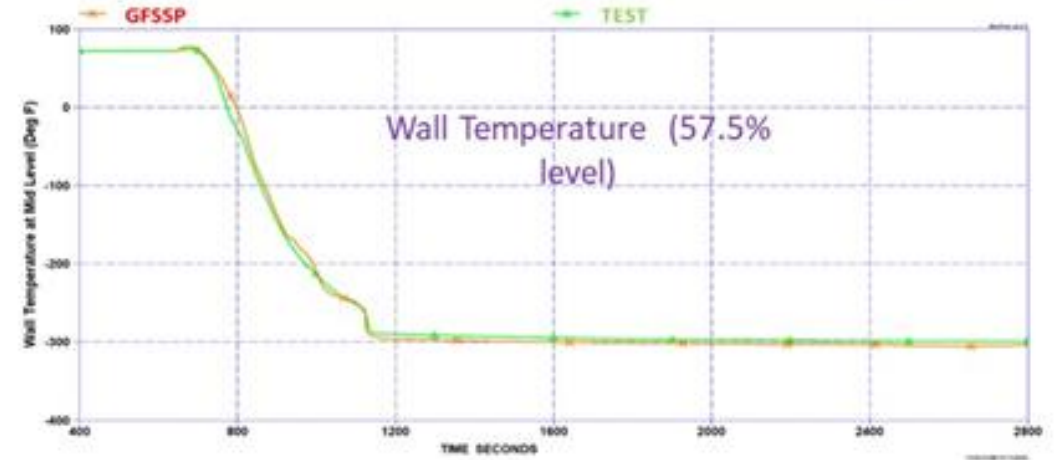
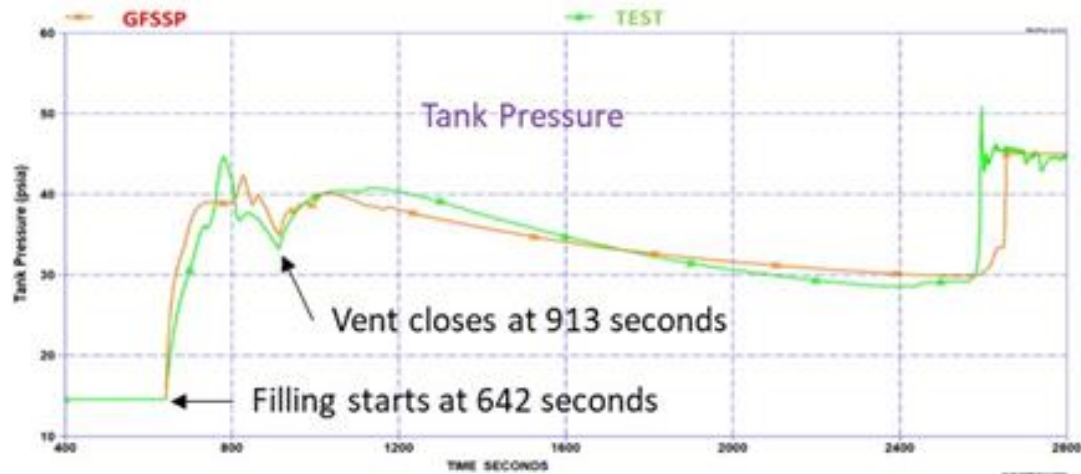

The predicted data compare with Test Data within 5%



# No Vent Fill with TVS assisted Injector

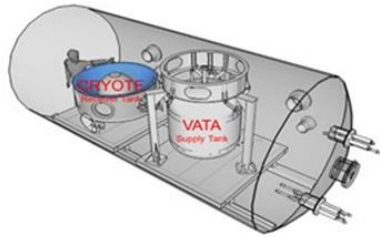

Condensation around spray droplet

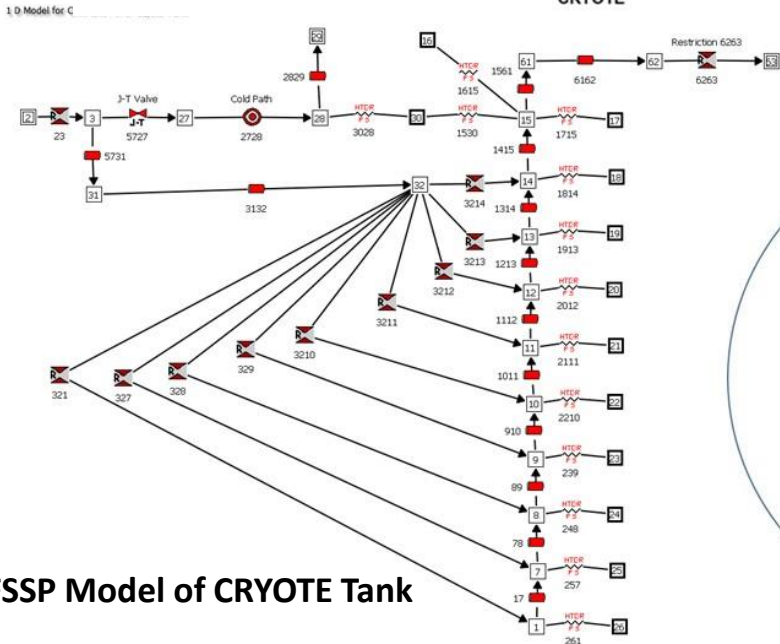
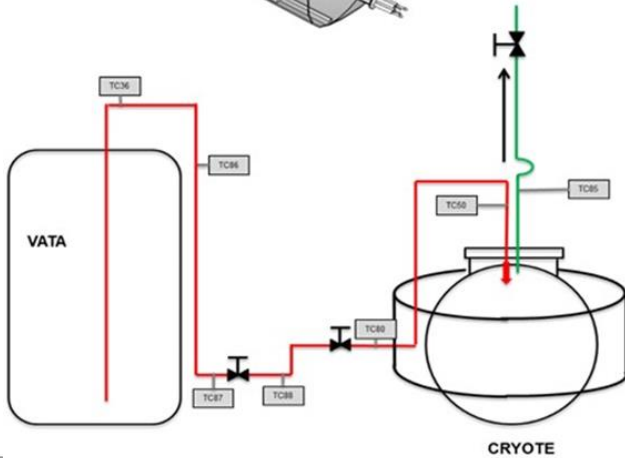
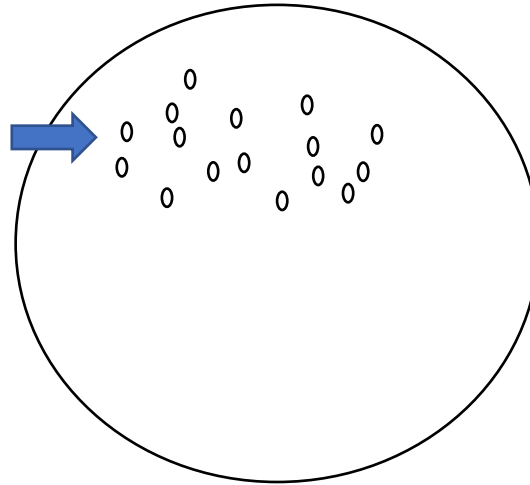

GFSSP Model of CRYOTE Tank

Condensation at Injector wall

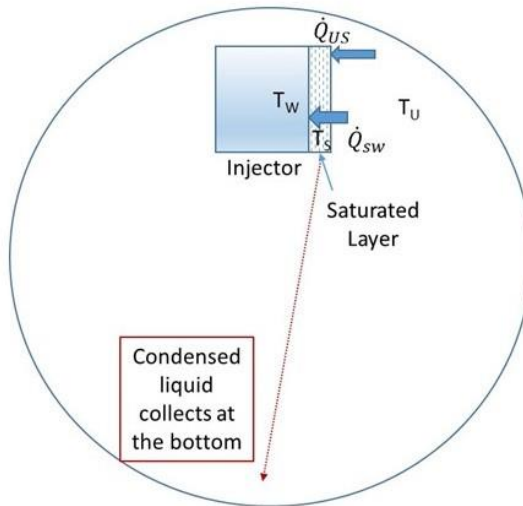

Pool Boiling at the wall

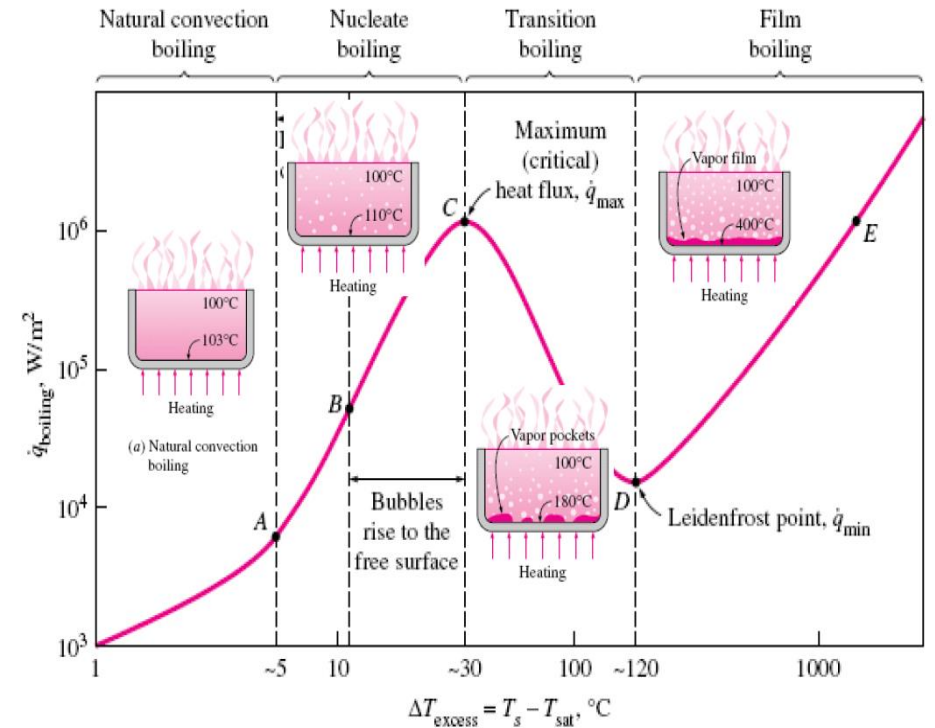



# Comparison of Numerical Predictions with NVF with TVS assisted Injector Test Data

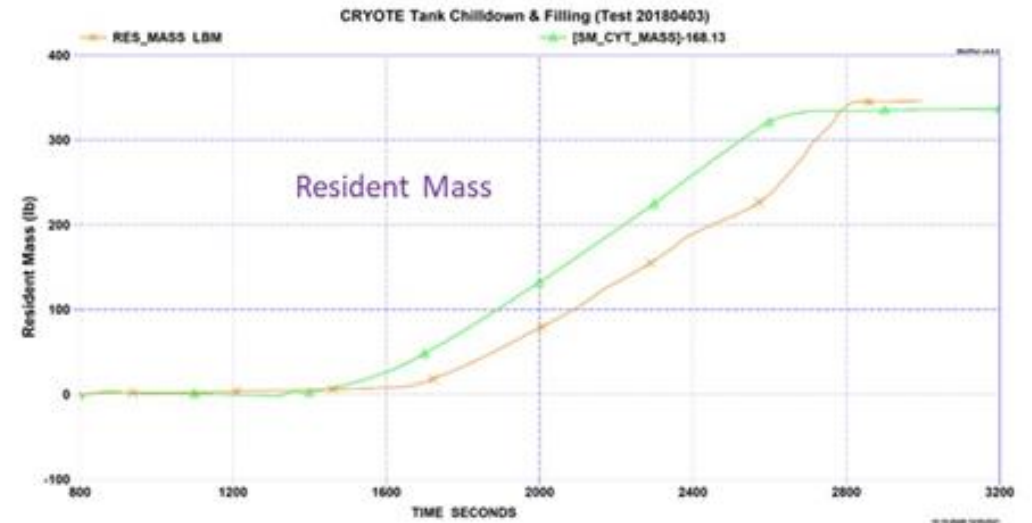

The predicted data compare with Test Data within 20%

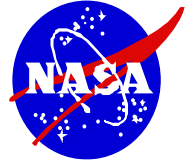

# Summary

- Several Liquid Propulsion System modeling applications using GFSSP have been described. The applications include a) Tank Pressurization, b) Chillover of Cryogenic Transfer Line, and c) No Vent filling of Cryogenic Tank.
- Single node pressurization model was used to model a large propulsion article with two propellant tanks with pressure control valve.
- Multi-node ullage modeling was used for self-pressurization of flight like tank with multi-layer insulation and Thermo-dynamic vent system.
- GFSSP models have been developed to model chillover of both long and short cryogenic transfer line. The chillover time and temperature distribution compares well with test data.
- Multi-node models of Tank Filling were developed for Vented Chill and No Vent Fill, and No Vent Fill with TVS augmented injector.
- Boiling model at the wall and an *ad hoc* condensation model around spray droplet, injector wall, and liquid-vapor interface were developed in User Subroutines.
- The numerical prediction of tank pressure and resident mass was within 20% of the measured data.



***Thank You !***

***Questions?***