

Wheel Module Motor Trade Study for Lunar Terrain Vehicle Thermal Control System

Samuel J. Wilcox¹

Jacobs Technology Inc., Houston, Texas, 77058

Conducting a lunar mission, whether it is a robotic mission or one with astronauts, has many challenges; one of which is the thermal control of the motors of the wheel module that are used to propel and steer the vehicle. This paper describes the thermal analysis approach, design assumptions, and results of passive thermally controlled wheel module motors, meaning there are not cold plates, fluid loops, or other active thermal control methods to controlling the temperatures. It will also highlight challenges faced in the design of wheel modules for a rover on the lunar south pole. There are three main design change approaches that are considered, the first one keeps the nominal design with the motors mounted at the wheel hub on each wheel, but the motors have lower temperature limits. The second approach requires no thermal control of the motors, allowing them to get below the manufacturers lowest thermal limit and warming them back up prior to actuation during the lunar day. The last approach moves the motors inside of the main body of the vehicle.

I. Nomenclature

<i>DSNE</i>	=	Cross-Program Design Specification for Natural Environments
<i>CONOPS</i>	=	Concept of Operations
<i>EHP</i>	=	Extravehicular Activity & Human Surface Mobility Program
<i>HLS</i>	=	Human Landing System Program
<i>K</i>	=	Kelvin
<i>LRO</i>	=	Lunar Reconnaissance Orbiter
<i>LRV</i>	=	Lunar Roving Vehicle (Apollo)
<i>LTV</i>	=	Lunar Terrain Vehicle
<i>MLI</i>	=	Multilayer Insulation
<i>PSR</i>	=	permanently shadowed regions
<i>TCS</i>	=	Thermal Control System

¹ Thermal Analysis & Test Engineer, Thermal & Life Support Systems Analysis

II. Introduction

NASA’s Extravehicular Activity & Human Surface Mobility Program (EHP) was created to lead the way for “safe, reliable, and effective spacewalking and surface mobility capabilities that allow astronauts to survive and work outside the confines of a base spacecraft in order to explore on and around the Moon” [1]. As part of this initiative, it is planned for astronauts to not only land on the Moon, but to also spacewalk on the Lunar surface and collect samples of the rocks, dust, and regolith that they are walking around and on. Not only astronauts, but robotic landers will also be roving the lunar surface to collect samples and prospecting for water or other volatiles that could potentially be frozen underneath the surface.

As part of EHP, the Lunar Terrain Vehicle (LTV) project has turned to the industry for bids to create the next generation roving vehicle for the use of humans on the lunar surface and extending the exploration capabilities of astronauts on the Moon. The LTV is expected to be operated as a robotic vehicle in between manned missions, which will take place approximately once a year for 10 years. As part of the process, it is necessary for NASA to develop an advanced concept or reference design so engineers and project management can better understand what is necessary, and what the challenges are in the fulfillment of this effort. As such, several papers have been written by the LTV Thermal team which this is but one of. This paper explains one such effort.

Previous work completed and detailed in the report [Surviving the Lunar Night, A Non-Nuclear Thermal Control System Approach](#), from January 2022 describes the heater power needed to endure the 150-hour lunar night scenario. Within this data, the nominal night survival case required 9.7kWh of total heater power to survive the lunar night; much of this power, over 90%, is used to keep the wheel modules warm. Because of the high impact of wheel module heater power on the overall amount of power required for survive the night, this paper will focus on the wheel modules specifically. In this paper, thermal impacts of the following different design options are studied: a wider temperature range for motors, freezable motors that are heated back up to operational temperature after the lunar night and moving motors from their outboard location to inboard inside a warm box. Alternate motor or tire designs, removal of components, and controlling the conduction from the tire to the ground are out of scope for this study. Other projects may benefit from the work presented in this document and are encouraged to study the data here as a starting point to build on the lessons learned from LTV.

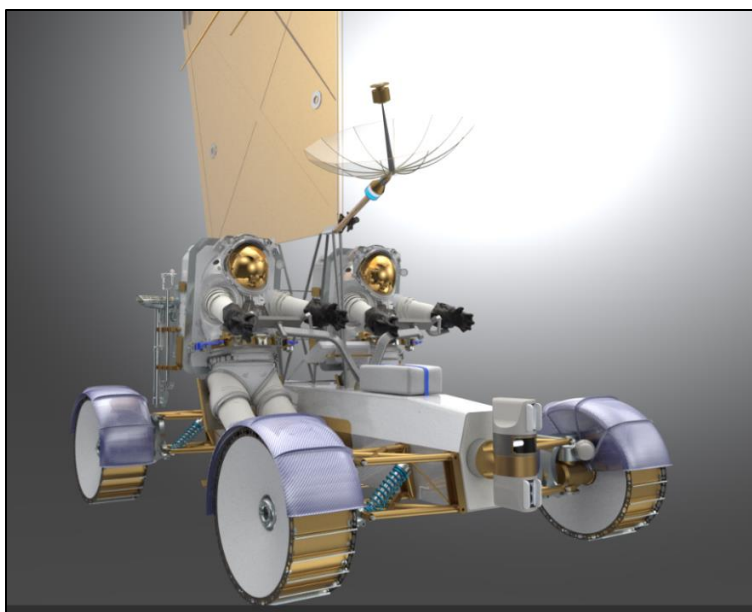

Figure 1: LTV CAD Concept

III. Landing Site Environment

During the landing site selection process for LTV, many considerations were made including possible locations of water-ice in a permanently shadowed region (PSR), of which the Shackleton crater area of the South Pole-Aiken

(SPA) basin provides a few options for exploring. The SPA also has other geological points of interest, and solar illumination that allows for the crew to work and solar power for the vehicle. Roving along the ridge between the Shackleton and de Gerlache (dG) craters provides many scientific studies to be performed and minimizes the duration of lunar night that needs to be overcome from 14 earth-days (336 hours) to as low as roughly 1 ½ earth-days (36 hours) through careful mission planning. This method, sometimes called “chasing sunlight,” is higher risk, and reduces the number of scientific studies that could be accomplished below a threshold preferred by NASA. If roughly 6 earth-days (150 hours) of night could be survived, then significantly more science could be conducted, so it is this 150-hour night survival requirement that is used throughout the LTV project. It is understood that this 150-hour night will not be encountered by astronauts and will only take place during an uncrewed portion of the LTV mission.



**Figure 2: Location and setting of the lunar south pole (shown by arrow). Shown area is the SPA basin. [2]
“dG” is for de Gerlache.**

The thermal environment of the lunar south pole region is well characterized due to the Lunar Reconnaissance Orbiter (LRO) being in orbit and gathering data since 2009. It “spent its first three years in a low polar orbit collecting detailed information about the moon and its environment. After this initial orbit, LRO transitioned to a stable elliptical orbit, passing low over the lunar south pole” [3]. One of the instruments on LRO is the Diviner Lunar Radiometer Experiment and has operated continuously since July of 2009 collecting detailed day and night surface temperature measurements of the Moon. “With the exception of Mercury, the Moon has the most extreme surface thermal environment of any planetary body in the solar system.” [4].

The data shown on the following three figures give similar information in different formats, but all are LRO Diviner data. The landing site on the connecting ridge between Shackleton and de Gerlache craters is between 88°S and 89°S, and when the data only shows 89°S data (i.e. Figure 8) it is assumed that the data for 88°S is extremely close to the 89°S data. For Figure 4 and Figure 5, the data for the landing site can be gathered directly from the temperature map. Diviner data is available to the public and has been used to create temperature maps of the lunar surface which show the temperature extremes of Polar Summer Min, Polar Summer Max, Polar Summer Average, Polar Winter Min, Polar Winter Max, and Polar Winter Average. These maps are available on LROC QuickMap found at (<https://quickmap.lroc.asu.edu>). The Human Landing System Lunar Thermal Analysis Guidebook contains detailed instructions on accessing and utilizing this resource and for more resources available from the Diviner team [6].

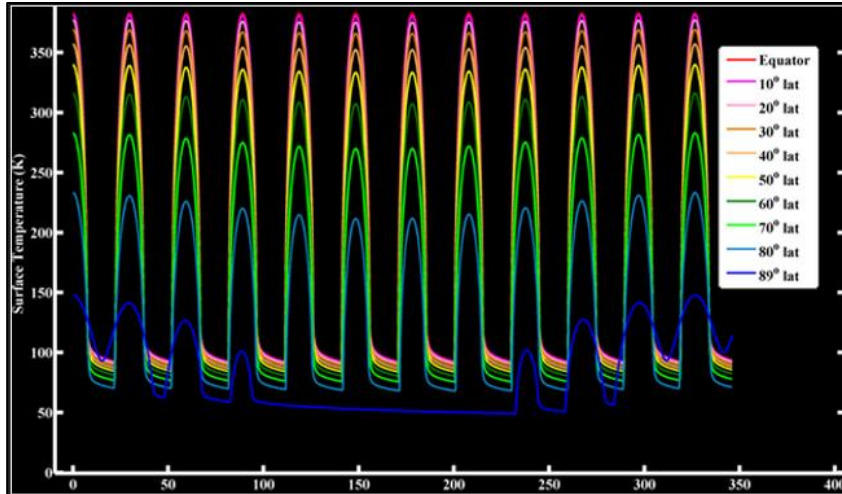

Figure 3: Monthly and annual lunar surface temperature variations at various latitudes [4]

The LRO Diviner data description is a little ambiguous, but it is assumed that the data in Figure 3 is the average temperature per Earth-day at the latitudes defined in the legend. Table 1, from the same publication, describes the Polar Average Temperature as $\sim 98\text{K}$ outside of shadow and a minimum temperature of $\sim 25\text{K}$ in a PSR. It can be seen from this data that during the “summer,” or hottest part of the year, on the lunar surface at 89°S the temperature peaks at $\sim 150\text{K}$ on average and during the “winter,” or coldest parts of the year, the lunar surface is just above 50K at 89°S .

Table 1: Moon surface temperatures [4]

Lunar Surface Average Temperatures		
Equator Noon	390 K	
Equator Midnight	95 K	
Polar	98 K	
Minimum Overall	25 K	Hermite Crater
Maximum Overall	410 K	Small equatorial craters

The temperature map in Figure 4 shows LRO Diviner data for the lunar south pole summer from 85°S (the white circle) to 90°S (the crosshair) in Kelvin. Shackleton (Sh) crater is just below and to the right of the south pole (90°S) with the de Gerlache (dG) crater directly to the left of the crosshairs and the connecting ridge between those two craters (roughly shown with the white curvy line). Along this connecting ridge the temperature on the surface varies between $\sim 220\text{K}$ and $\sim 300\text{K}$ during the summer depending on where along the ridge the vehicle is located.

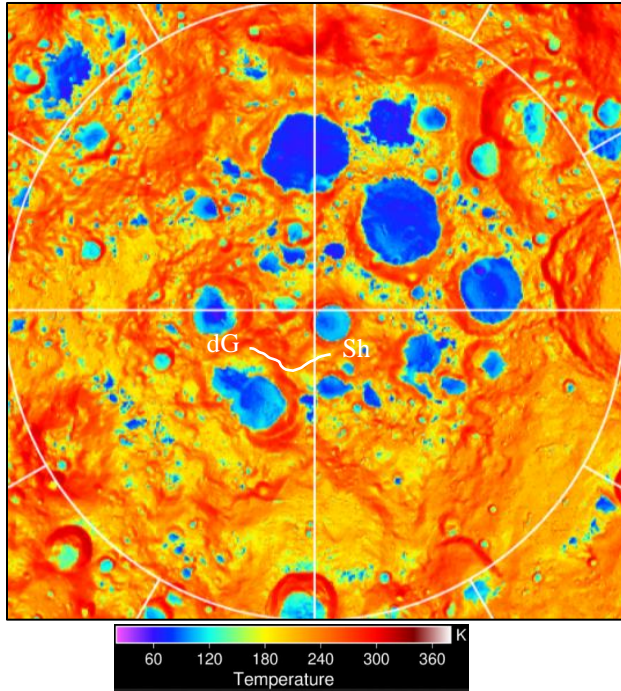

Figure 4: 85°S to 90°S Summer maximum temperature readings from LRO [5]

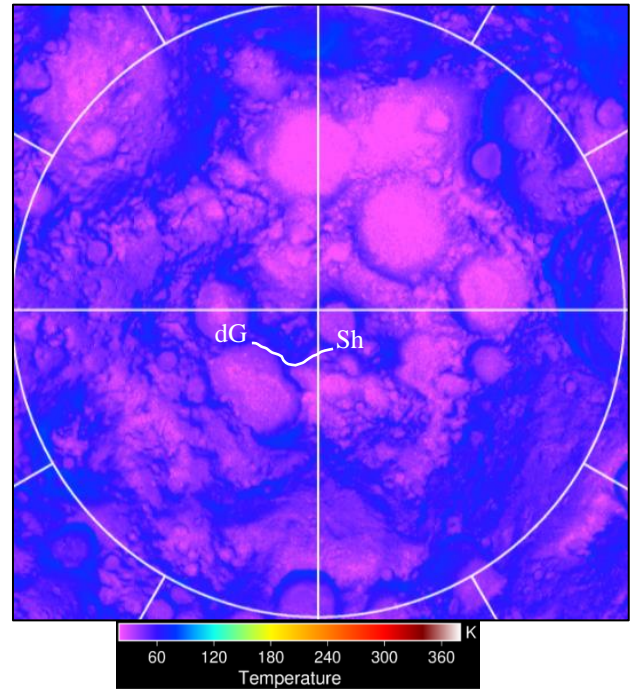

Figure 5: 85°S to 90°S Winter minimum temperature readings from LRO [5]

The temperature map in Figure 5 shows LRO Diviner data and is the same map as Figure 4 except that it is the minimum Winter temperature readings. Labels for Shackleton (Sh) crater, de Gerlache (dG) crater, and a rough outline of the connecting ridge are included. Along the connecting ridge the temperature on the surface varies between ~50K and ~70K during the winter depending on where along the ridge the vehicle is located.

In the thermal model, the temperature of space is maintained at 3K and is represented as a radiative sink temperature in Thermal Desktop. The thermal model includes a representative lunar surface directly around the vehicle to attain more realistic thermal effects from the ground. The lunar surface model was created based on the Human Landing System (HLS) Lunar Thermal Analysis Guidebook [6] and the Cross-Program Design Specification for Natural Environment (DSNE) [7] which give detailed descriptions on the distance from the vehicle the surface should extend, thickness of the dust and regolith layers, conductivity of each layer, conductivity between the layers, density of each layer, specific heat of each layer, absorptivity of the dust layer, emissivity of the dust layer, and sub-surface heat generated. This paper will not discuss the modeling of the lunar surface, so if more detail is needed on how to do that, please see the referenced guidebook and document. It is sufficient to say that the thermal model created ensures that the modeled ground reaches and maintains the temperatures described above for the respective cases, and what has been described above is sufficient to outline the thermal environment and initial temperatures.

IV. Thermal Design Description

A. Thermal Model of Lunar Surface and Environments

The lunar surface directly adjacent to the LTV was built in Thermal Desktop as solid surfaces that absorb and reflect heat to get the best possible results and strictly adhered to the HLS Lunar Thermal Analysis Guidebook in the building of the model. The environmental temperatures from the completed analysis model closely match the LRO data previously presented when the build of the lunar surface model is completed correctly.

The optical properties of the lunar surface, which are needed for how much solar heat gets reflected off the lunar surface to the container and are applicable for this documents' purpose, are as follows:

- Emissivity = 0.97

- Absorptivity = 0.87

Figure 6 and Figure 7 show the LTV thermal model. The LTV is placed on the lunar surface at 89°S latitude, as described previously, and the analysis primarily focuses on the LTV being on the shadowed side of the Moon. An adequate physical representation of the analysis would be that the LTV is either being driven or is parked, without astronauts onboard, in the daylight and suddenly night falls and lasts for the 150-hour duration of the analysis. This method of modeling the day-night transition on the Moon is reasonable since there is no atmosphere on the Moon to diffuse the heat from the Sun like on Earth; so, the transition into any type of shadow results in near-immediate decrease in temperature although the mass of objects, or regolith, does slow the process some. It is from this cold analysis that is the most extreme realistic “cold” example that could likely occur, that the heater power needed to survive the lunar night is gathered.

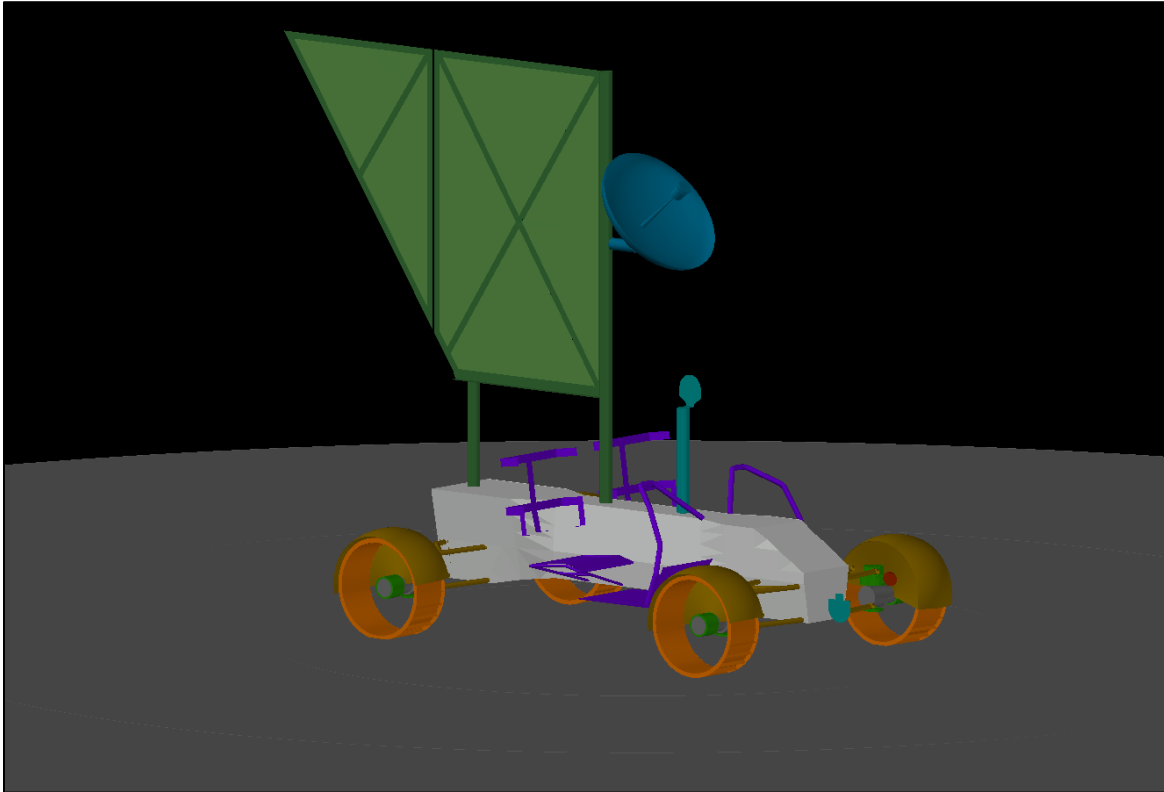

Figure 6: LTV thermal model as built in Thermal Desktop

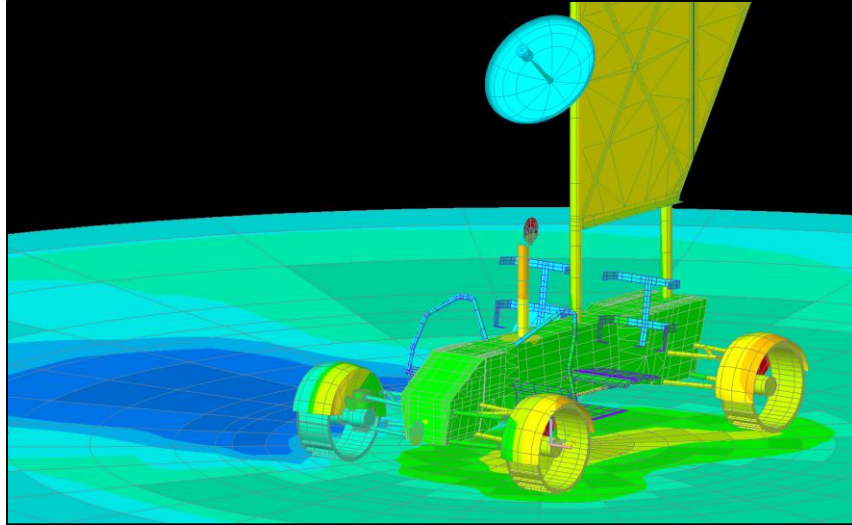

Figure 7: LTV thermal model showing temperature gradients on the lunar surface. The sun is on the right side of the figure, out of view.

For visual understanding only, more discussion on thermal results later.

A good TCS design does not rely solely on cold analysis but is also balanced with the “hot” realistic extreme scenario that is also likely to occur. The hot analysis in this trade study was a single case, intended to check the design for any major complications. The scenario used was of the vehicle continuously roving in sunlight for 6 hours, with or without astronauts onboard. This requires the batteries to be dissipating their maximum amounts while in sunlight, and most other units also being ‘on’ and generating heat. The analysis concludes at 6 hours since that is the assumed amount of time from the LTV project available to the astronauts for a roving EVA given that it takes them time to egress and ingress the lander spacecraft.

B. Thermal Design and Model of the Wheel Modules

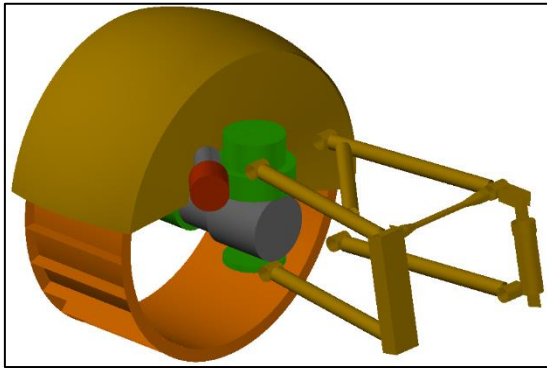
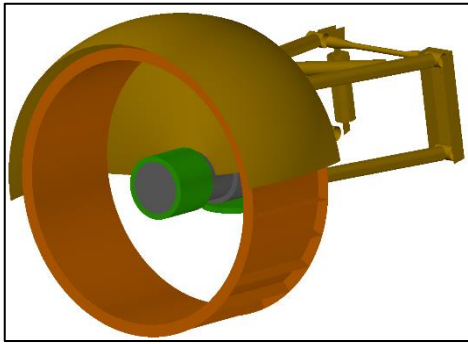

Figure 8- Wheel module

complete detail of the structure's heat conduction path without having to include an excess amount of detail in the model, although either approach would enable the designer/engineer to perform the necessary energy balance equation. Multilayer Insulation (MLI) is not shown in Figure 8 but encloses the struts and motors, leaving the wheel and fender exposed.

The MLI effective emissivity (e^*) being used in this model and for all analysis is 0.05, which is not as insulative as might be considered common on other projects but also attempts to account for inefficiencies of a lot of small surface area and being flexible. This is considered a conservative approach. A more realistic e^* might be considered of 0.03, which is more insulative but is more common for larger surface areas where the MLI is not bent or misshapen and is instead flat over a relatively large area.

All night survival scenarios assume no dissipation from any unit; this will yield a worst-case heater power requirement that the system can then use to select heaters (power rating & physical size) with appropriate margins of safety and a circuit layout. The nominal night survival case will be discussed in detail in the following subsection, but it is assumed that the baseline night survival case is preceded by all units being warmed to their maximum temperature limit to facilitate the maximum duration of night survival.

C. Analysis Approach

Several analysis cases have been run with the vehicle system-level model and it was from that effort that worst-case hot and cold scenarios can be chosen for the thermal system. That case matrix is shown in the below bullets:

- Basic operational scenarios
 - Parked with the sun on one side for 6 hours, initialized with steady state calculations.
 - Parked with the sun on the front for 6 hours, initialized with steady state calculations.
 - Parked on a slope, with the sun on one side for 6 hours.
 - Parked on a slope, with the sun on the front for 6 hours.
 - **Roving with the sun on one side for 6 hours.**
 - Initialized by the end results of “Parked with sun on one side” case.
 - Roving with the sun on the front for 6 hours.
 - Initialized by the end results of “Parked with the sun on the front” case.

Previous analysis has covered an overview of the LTV TCS where the wheel modules are mounted directly to the main body of the LTV and the whole LTV is accounted for in the radiation calculations. This analysis focuses solely on the wheel modules and the sensitivities to different design options with the motors. The rest of the LTV vehicle is still included the thermal model used in this analysis. Each of the four wheel modules in the LTV thermal model are built the same, and all are mounted to the main body of the LTV using the same conduction value.

Figure 8 shows the assumed baseline wheel module design. Each module consists of a grouser-type wheel (orange) with a fender (yellow), both of which are in contact with the propulsion motor. The wheel is in contact with the propulsion motor (shown by the green and grey horizontal cylinder) by titanium spokes, which are not shown in Figure 8 but are mathematically accounted for in the model. The fender is modeled as a single piece of fiberglass and is directly mounted to the propulsion motor housing.

The steering motor (shown by the red and green cylinders above the propulsion motor in grey) is within the same housing as the propulsion motor but is controlled to a separate temperature limit by a separate heater circuit. The wheel module support structure and suspension can be seen in yellow and are represented by the various rods. Similarly with the wheel spokes, the support structure is mathematically in contact with each member of the structure as well as the steering and propulsion motor housing. This allows for a

- Temporary entry into PSR scenario
 - Roving with the sun on one side for 2 hours, before PSR entry
 - Roving in PSR for 2 hours
 - Roving with the sun on one side for 2 hours, after PSR exit
- Temporary entry into a shadowed region (not a PSR)
 - Roving with the sun on one side for 2 hours, before PSR entry
 - Roving in PSR for 2 hours
 - Roving with the sun on one side for 2 hours, after PSR exit
- Survive the night scenario.
 - ***150 hours of night survival, preheating all units to their maximum temperature limit***
 - 150 hours of night survival, preheating all units to the average of their maximum and minimum temperatures.

The worst-case hot CONOPS scenario has been assumed to be when the vehicle is roving continuously for 6 hours with its side to the sun, shown in bold and underlined in the above bulleted list. This includes all the units on the vehicle dissipating their maximum amount of heat dissipation and is initialized with the vehicle parked with its side to the sun, but no dissipation during the parked period. The CONOPS scenario this represents could be any scenario in which the vehicle is parked for 8 hours in the sun, whether that be while the vehicle is charging the batteries, or is parked between EVAs, or any other such scenario. After the parking period, the rover then begins roving in the sun for 6 hours without any stops or any other interruptions simulating a long duration roving operation with the sun being on one side of the vehicle. This would not be representative of an EVA roving operation since that would most likely be out-and-back with at least some stops; but could be representative of a science destination and a continuous roving operation to get to that point.

The worst-case cold CONOPS scenario has been assumed by the LTV project to be 150 hours of lunar night and prior to the vehicle going into a night survival mode, the vehicle would utilize the heaters and warm all units to their maximum temperature limit. This scenario is shown in bold and italics in the above bulleted list. The details of the work and concept design that influenced this decision can be found in a report in January of 2022. The scenario represents any time when the vehicle is preparing to enter the lunar night, parks, and does not have any motion for the duration of the night scenario. PSR operations are not considered in this report since they have not been identified as the worst case and are not the driving design factor.

There are three design changes that were considered besides the nominal design of the motors mounted at the same location with a wheel hub on each wheel. The first approach is to have the motors in the nominal location, but to have colder temperature limits and maintain those limits with heaters. The second approach has the same number of motors as the first but has almost no thermal control and allows the motors to get below their lowest thermal limit and warming them back up prior to actuation during the lunar day. The last approach moves the motors inside of the main body of the vehicle. This design assumed that there was no additional hardware needed to move the wheels which are outside the main body. Various scenarios are also included to assess the amount of heater power needed to warm up the motors after the night survival to a point that the motors can safely function.

- Motors with lower temperature limits
 - Post-night warm up including heaters.
 - Post-night warm up does not include heaters.
- Motors with no heater control
 - Post-night warm up including heaters.
 - Post-night warm up does not include heaters.
- Motors moved inside of the main vehicle body.

It is important to note at this point that the design and analysis at this point of development for the LTV wheel modules is not complete. The analysis results discussed in the following section do not give a completed design, but it will highlight the challenges that are faced in the wheel module analysis. There is a great deal of confidence that a design solution is possible, but future work is needed. This report is only intended to show challenges so that when contractor selections are made for the LTV project, the NASA team may be well informed and able to readily provide insight.

V. Analysis Results

The biggest challenge for the thermal team is the balancing of hot and cold temperature limits, especially while one side of the rover or vehicle is in the sun and the other is in shadow. If active cooling loops are not used (or not practical), the only things that are available to manipulate are conduction paths, coatings, which change the optical properties, and MLI coverage of the motors. The selected coating must be able to emit the heat generated by motors while driving and reflect as much heat from the sun as possible. At the same time, this coating must not allow too much heat to be rejected from motors in the shade or overnight to keep the motors above their low temperature limits. This is something to make note of while evaluating designs.

A. Baseline Hot Case

As discussed previously, the worst-case hot scenario has been assumed to be when the vehicle is roving in the sun, with its side to the sun, for 6 hours at 89°S latitude. This case is initialized with the vehicle parked with its side to the sun and no units are producing any dissipation. Rather than using an arbitrary starting temperature for the motors, the case uses steady state calculations to begin the parked case, then the case resumes for 6 hours to obtain a transient solution prior to beginning the roving side sun analysis. This analysis assumes the sun is on the starboard side of vehicle and the port side is facing a dark sky.

Notice in Figure 9 the steering motors oscillate at -40°C due to heaters maintaining the steering motors above their assumed lower temperature limit of -40°C. The steering and propulsion motors have a maximum temperature limit of 50°C and is an assumed value from the beginning of the project. Specific details of the motors or actuators may vary and are highly dependent on the actual motors/actuators being used in the production of the wheel modules. The maximum temperatures of the propulsion and steering motors in the starboard side of the vehicle are already above the limit of 50°C, and while it is possible to find a solution to get all motors within their limits, it is out of scope of this and the previous analysis. This is a good opportunity to highlight the challenges in designing a wheel module for a rover on the lunar south pole region.

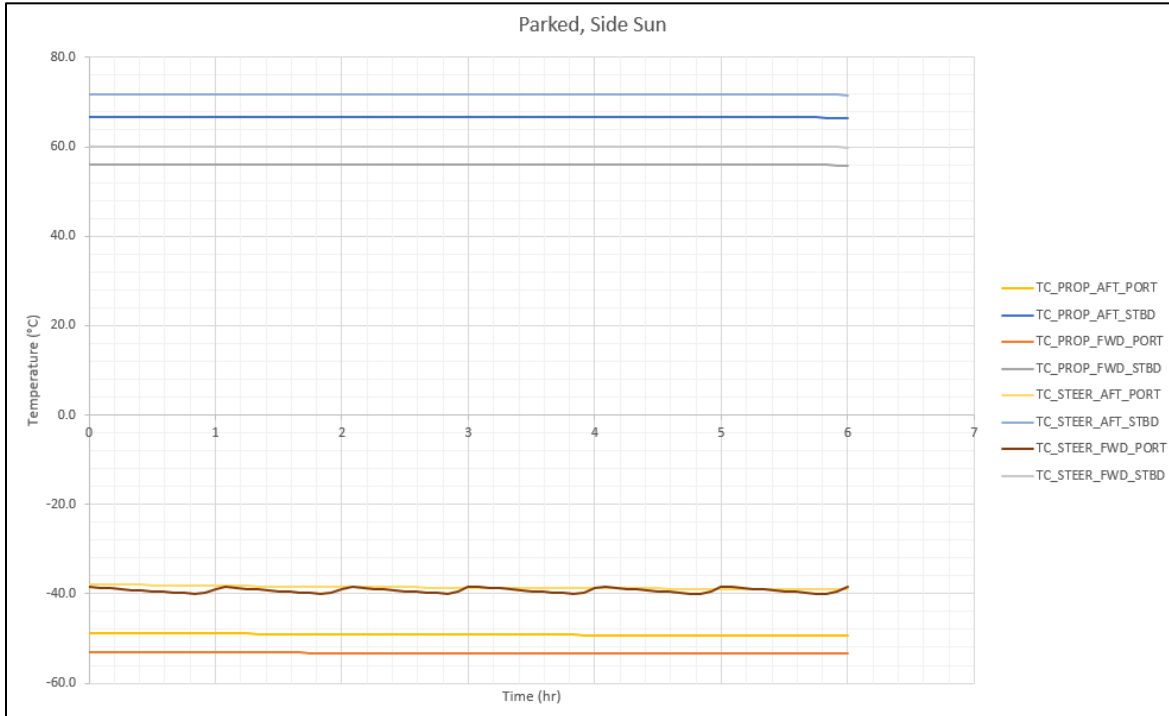

Figure 9: Propulsion and Steering motor temperatures of the Parked, Side Sun case

The final temperatures shown in Figure 9 were used to initialize the roving, side sun case and then a 6-hour roving operation was completed. This roving operation remained with the same side facing the sun the entire time,

representative of a robotically controlled mission going to a waypoint, with all units on the rover generating heat. While this may not actually occur, at the time this analysis was completed actual routing or specific CONOPS are not known, and so is a conservative approach. At this stage of development, conservatism is warranted.

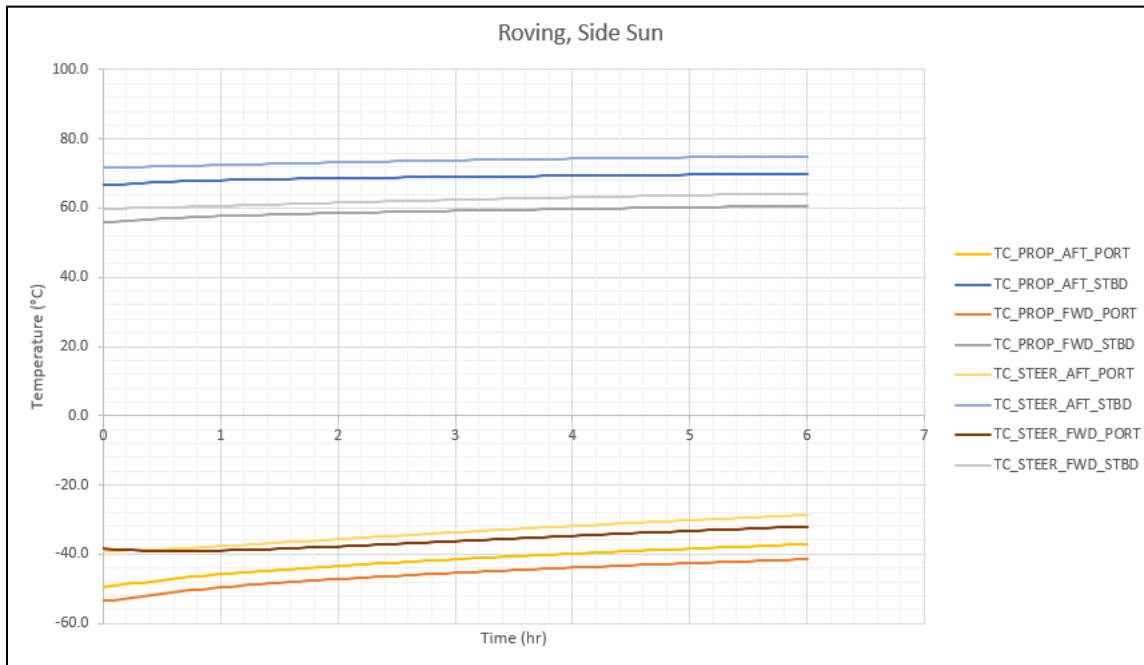

Figure 10: Propulsion and Steering motor temperatures of the Roving, Side Sun case

Between Figure 9 and Figure 10, the resulting temperatures for the propulsion and steering motors can be seen for the likely scenario of a rover being parked in the sun, at lunar local noon with one side of the rover facing the sun, then performing a roving maneuver with the same side of the rover continuously facing the sun and still at lunar local noon. Also in both figures, two sets of data can be seen: a set of blue and gray trendlines representing propulsion and steering motors on the starboard side of the vehicle, and a set of yellow and orange trendlines representing propulsion and steering motors on the port side of the vehicle. The starboard side of the vehicle was the side chosen to face the sun for the analysis, and the port side remained in the shadow of the vehicle; this is why there is a large temperature difference between the data sets, one side is in the sun, and the other in the shadow of the vehicle.

In Figure 10, a rise in temperature from time zero to the 6-hour end time which is due to the heat being generated by the motors. that the assumed maximum temperature limit of the motors (50°C) has been exceeded, but whether this is a serious problem or not is unknown since the actual motors are yet to be developed. A simple, yet extremely effective mitigation would be to not run the motors continuously at full power for long durations of time. A closer look may be warranted to find how long the motors can be run at full power. But since this design is only being used as a reference against proposals being received, the time needed to get all the details of the wheel module worked out is not taken at this stage of the development. While there is still some work to be done if/when a final design for the wheel modules gets developed, this gives a good picture of the hot case results that need to be balanced with the focus of this report – the cold case.

B. Baseline Cold Case

The baseline cold case that was analyzed was 150 hours of a lunar night survival with all units being pre-heated to their individual maximum temperature limits. The propulsion and steering motor results of this analysis can be found in Figure 11. The night survival begins with the propulsion and steering motor temperatures set at 50°C, the assumed operational maximum temperature. The motor temperatures drop over time and as they reach their low temperature limit the heaters turn on and begin maintaining the steering motors at -40°C. Then a few hours later, the propulsion motors also reach their low temperature limit of -60°C and heaters turn on to maintain that temperature limit.

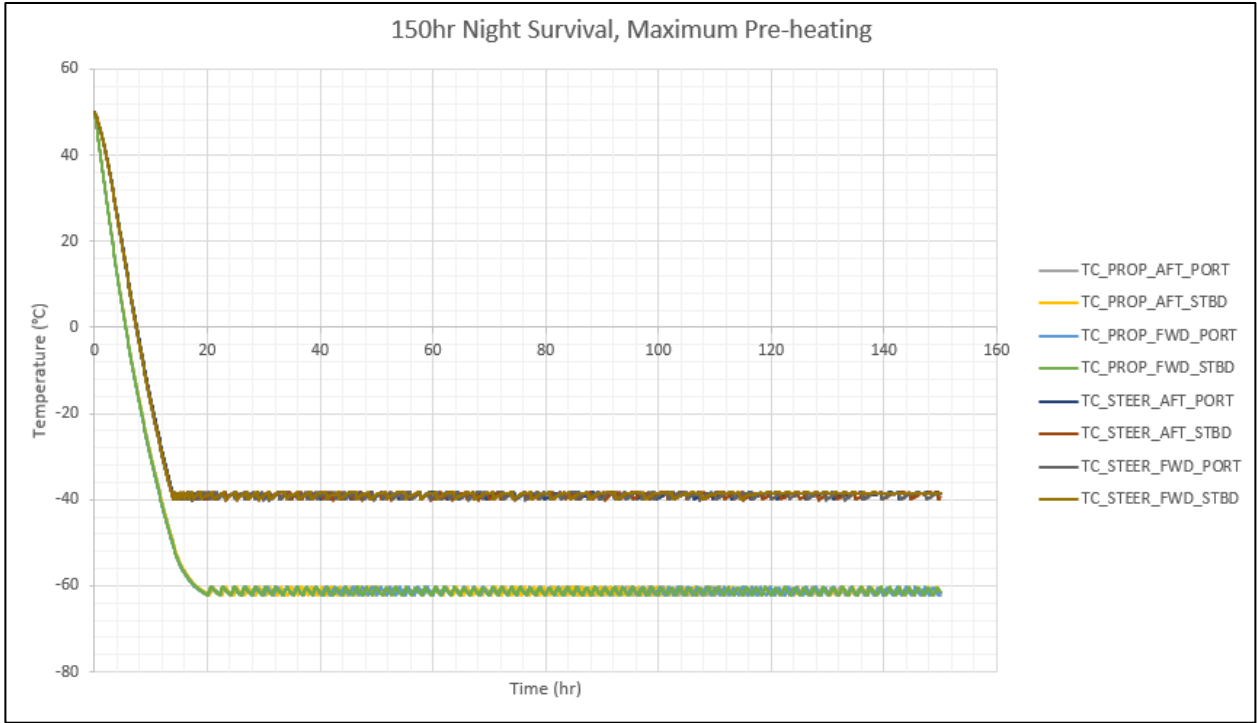

Figure 11: Propulsion and Steering motor temperatures, 150hr night survival with maximum preheating

The total vehicle heater power needed, while the propulsion and steering motors maintain their low temperature limit in the baseline cold case, is **9.7 kWh**.

C. Cold case – average preheating

The possible scenario where each of the units are only preheated to their average temperatures is the more conservative approach, and as such is the worst case that the thermal system should be prepared for. A scenario where the units are *not* pre-heated prior to the lunar night is not considered. The initial temperatures of the steering and propulsion motors for this case are based on the average of their maximum and minimum operational temperature and are set at 5°C for all motors. As can be seen in Figure 12, and is similar to the baseline cold case, the motor temperatures drop over time and as they reach their low temperature limit the heaters turn on and begin maintaining the steering motors at -40°C. Then a few hours later, the propulsion motors also reach their low temperature limit of -60°C and heaters turn on to maintain that temperature limit.

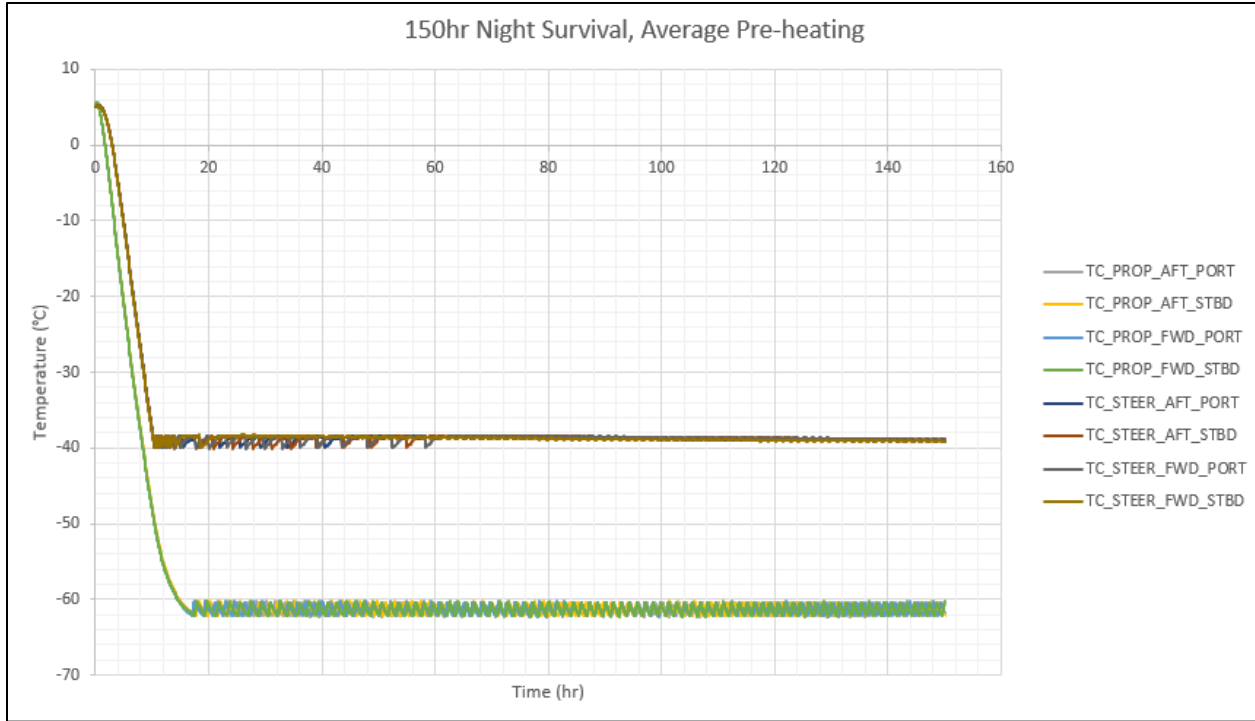

Figure 12: Propulsion and Steering motor temperatures, 150hr night survival with average preheating

The total vehicle heater power needed, while the propulsion and steering motors maintain their low temperature limit in the baseline cold case, is **10.7 kWh**. The difficulty with this value is that in order to provide this amount of power over the 150 hours of lunar night, the battery size must be able to provide it – so they must be relatively large with respect to the vehicle. The following analysis cases are approached in a way to best describe various options to decrease the amount of heater power needed on the motors, and thereby decrease the size and mass of batteries required to endure the lunar night.

D. Cold case – motors have lower minimum temperature limit.

Finding ways to lower the minimum temperature limit of the steering and propulsion motors would allow the heaters to be turned on for a great deal less than the baseline and average preheating cases. This could be done by choosing or specially designing motors, lubricants, or electronics which can withstand colder temperatures in the non-operating condition. It is not the intention of the thermal team to direct the physical design of actuators or materials therein; nor is it within the scope of this report. With that understanding, an arbitrary minimum temperature limit was chosen for both the steering and propulsion motors and made to be -135°C. Doing this significantly reduces the minimum temperature limit of the steering motor, and greatly reduces the lower limit of the propulsion motors. This analysis is initialized by the average pre-heating scenario.

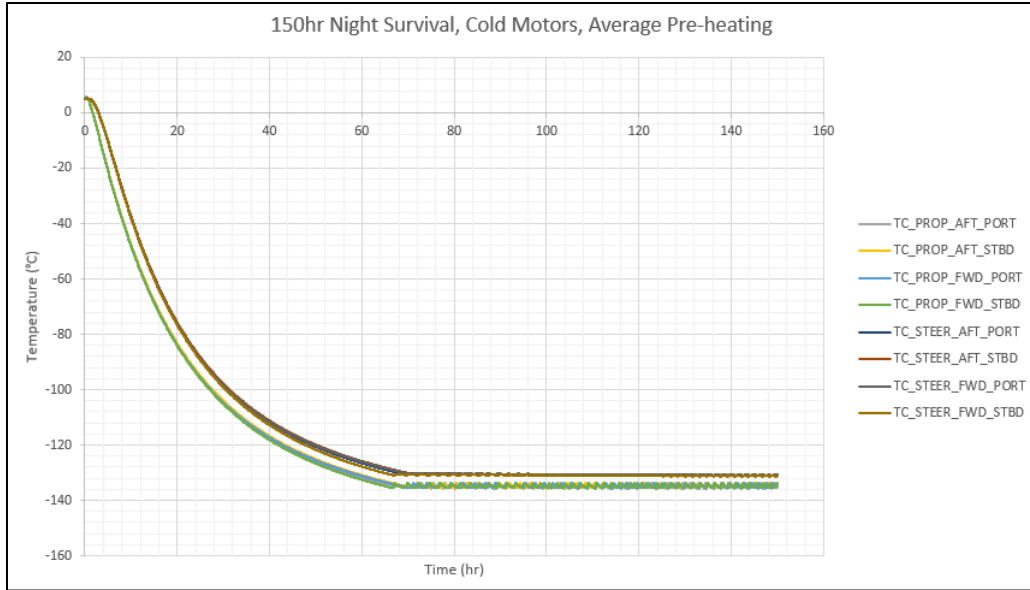

Figure 13: Propulsion and Steering motor temperatures, 150hr night survival, Cold Motors scenario

Finding a way to reduce the minimum temperature limit of the steering and propulsion motors proved to be a great method for reducing the amount of heater power required to survive the lunar night; and the resulting heater power from analysis shows this. The overall heater power required to survive the lunar night decreased from 10.7 kWh to **1.8 kWh**.

E. Cold case – motors have no heater control.

Another way to bring down the heater power from the baseline or average pre-heating cases would be to remove all heater control from the steering and propulsion motors. This would be allowing the actuators & motors of the wheel module to naturally cool down to whatever temperature the environment pulls them down to, well beyond their assumed lower limit temperatures previously assumed, but would also require heaters to warm up the actuators prior to operations after the lunar night has been completed. The heaters could be used only once the sun has been acquired by the solar panel so that battery power is not used and would not have to be accounted for in the size of the battery. This would save both heater power and mass.

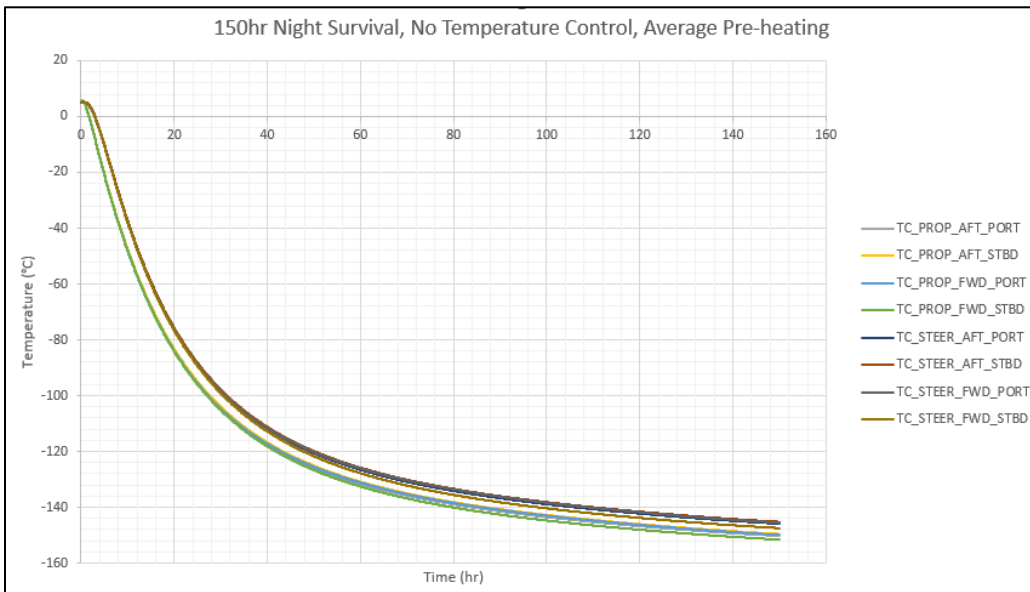

Figure 14: Propulsion and Steering motor temperatures, 150hr night survival with no temperature control

Allowing the motors to naturally cool down to whatever temperature they reach over the 150-hour night may prove to be too challenging for the materials and components of the actuators or motors, but if it is possible to achieve this then it would save an additional 1.1 kWh of heater power when compared to the lower temperature limit analysis case. Overall, this would bring the total heater power required to survive the lunar night from 10.7 kWh in the average preheating case (thermal system worst case) to **0.7 kWh** in this case.

F. Cold case – motors moved inside main body of vehicle.

The final trade conducted in this study was to move the steering and propulsion motors from outside of the main vehicle body mounted on suspension struts, to inside the main body of the vehicle. Doing this would protect them from the extreme cold of the lunar night and allow them to share in the heat from all the other units within the main body of the vehicle and decrease the amount of heater power required to survive the lunar night to the greatest extent possible. Among the benefits of this approach include having enough margin in the power budget to accommodate additional heater power for bearings or grease for gears that may need to be kept at higher temperatures than are currently being assumed. If the current temperature limit assumptions are stricter than what is needed for the actual units then the other design options would require an increase in heater power to survive the lunar night than what is predicted in the baseline, but for this design option the impact would be much smaller and more manageable. However, if this idea is even possible is largely unknown to the thermal team with the current NASA reference design and there are likely many challenges and other considerations to be addressed if such a design is chosen.

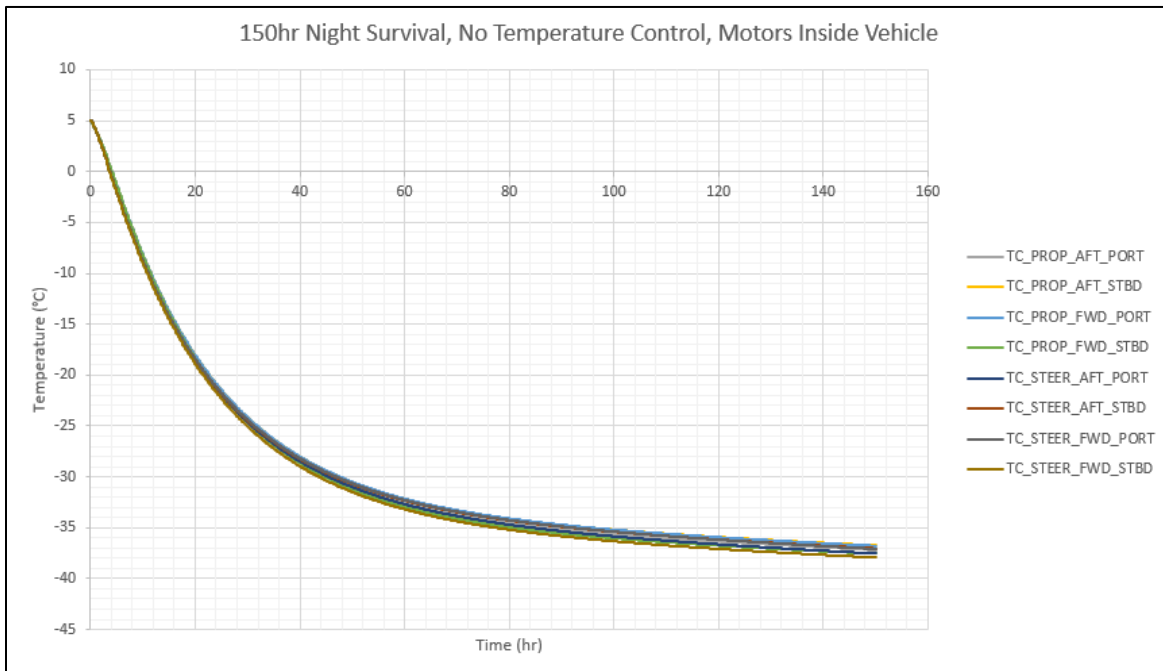

Figure 15: Propulsion and Steering motor temperatures, 150hr night survival with motors inside vehicle

As can be seen in Figure 15, the motors of the wheel module being mounted inside of the main body of the vehicle would keep them warm enough over the 150-hour night that their heaters are not needed. This scenario decreases the total amount of heater power required to survive the lunar night to **0.24 kWh**, the least amount proven that the thermal system requires. It is a huge decrease from the 10.7 kWh worst-case scenario as well as from the 9.7 kWh nominal case, but whether this is even possible is unknown with the current NASA reference design for LTV, but there are many challenges and considerations that would need to be addressed if such a design were to be chosen.

G. Heater power summary

Through the various thermal design trades detailed in the previous sections and sub-sections, the impact the wheel module thermal design to the overall heater power required to survive 150 hours of lunar night can be readily seen. Table 5 shows the overall heater power for the baseline scenario of a 150-hour night survival with pre-heating all units to their maximum temperatures, the thermal system’s assumed worst-case scenario of a 150-hour night survival with

units being pre-heated to the average of their individual maximum and minimum operational temperatures, the results of finding design solutions to decrease the minimum temperature limit of the motors (shown in the table as “cold motors”, allowing the motors to naturally cool to whatever temperature the environment drives them to without temperature control (shown in the table as “freeze motors”), moving the motors internal to the vehicle’s main body (shown as “motors inboard”), and finally an additional reference case of a 100-hour night survival scenario.

The values in Table 5 represent numbers that *do not* include any margin, so appropriate margins should be included if using these numbers as part of any kind of heater, battery, or other sizing efforts. Also, the thermal model of the NASA reference design does not include several units such as cameras, lights, payloads, star tracker, IMU, Gyros, robotic arm, and crew control devices; all of which may or may not be needed, but none of which are defined in the NASA LTV reference design. It has also been assumed that the solar arrays do not need any heaters, and if they do then the heater power would also be impacted with an increase.

Table 2: Total heater power for various night survival scenarios

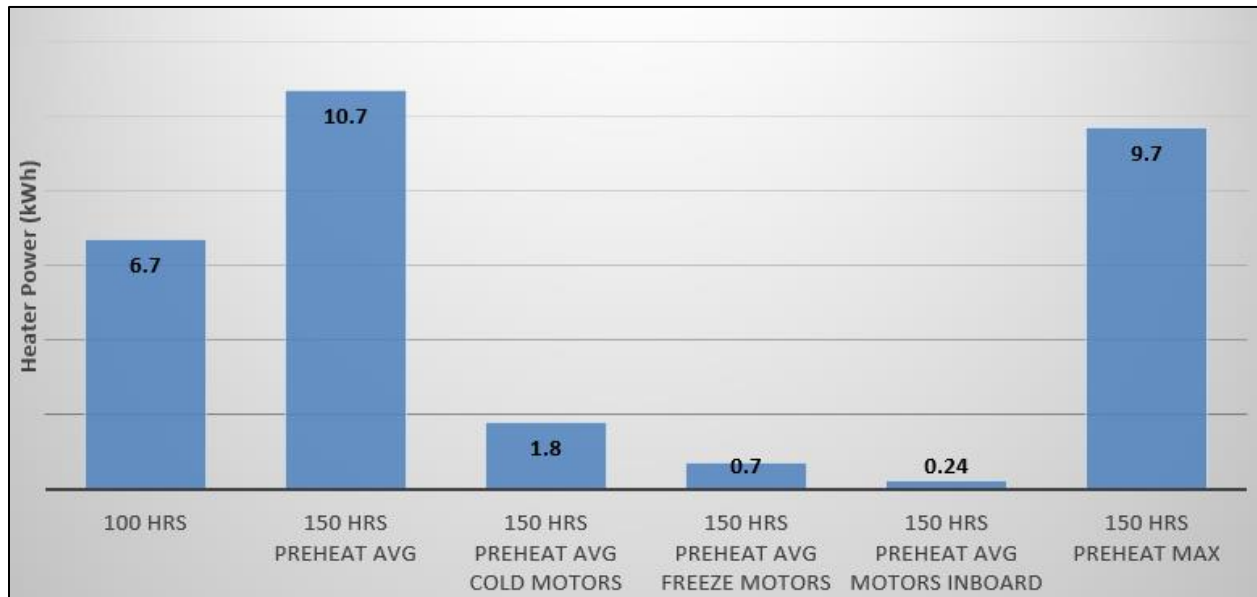

VI. Conclusion

The trade study detailed in this report looked at various design solutions to reduce the amount of heater power required to maintain the steering and propulsion motors at their assumed minimum temperature limits of -40°C and -60°C . The baseline design of having all steering and propulsion motors located at the wheel location, on the end of the suspension struts away from the vehicle main body gave a starting point and two different unit pre-heating scenarios were considered. A scenario that did not use any pre-heating of units was not considered as that required excessively large batteries in previous analysis work completed in 2022. Of the two pre-heating scenarios, the option to pre-heat each unit to the average of their maximum and minimum operating temperature is the worst case for the thermal system – so this is the pre-heating scenario that was used to find the impact to the heater power requirement.

Three alternative design options were considered: first, to have colder temperature limits of -135°C and maintain those limits with heaters. This reduced the overall heater power requirement from 10.7 kWh to 1.8kWh. Second, the motors have no thermal control thereby allowing the motors to get below their lowest thermal limit, or “freeze,” and warming them back up prior to actuation during the lunar day. This reduced the overall heater power requirement further to 0.7 kWh. Third, the motors have moved inside of the main body of the vehicle resulting in an overall heater power requirement of 0.24 kWh. These are all promising results; however, the implementation of these options may prove to be more difficult than is worth considering.

While there is no official recommendation following the completion of this trade study effort, the most promising avenue is to find ways to lower the minimum temperature limit of the steering and propulsion motors. This proves to be the single largest impact to the heater power required to survive the lunar night while also accommodating components like bearings on the motors and not letting those components completely freeze. Doing this, along with careful selection of optical coatings, thermal isolation, and MLI placement on and around the steering motors can also

allow for better heat rejection while operating in the sun without sacrificing cold case performance. Another option with potential to eliminate heater needs for the motors would be the possibility of moving the motors internal to the vehicle, however, that may come with many other difficulties such as rejection of heat during long-duration operation.

References

- [1] <https://www.nasa.gov/extravehicular-activity-and-human-surface-mobility/>
- [2] Spudis, P. D., et al., “Geology of Shackleton Crater and the south pole of the Moon,” *Geophysical Research Letters* 35: L14201, doi: 10.1029/2008GL034468, 2008
- [3] Dunbar, B., Hille, K., “LRO Mission Overview”, National Aeronautics and Space Administration, Aug 3, 2017, URL: https://www.nasa.gov/mission_pages/LRO/overview/index.html
- [4] Dunbar, B., Hille, K., “LRO Spacecraft Instruments”, National Aeronautics and Space Administration, Aug 3, 2017, URL: https://www.nasa.gov/mission_pages/LRO/spacecraft/index.html
- [5] Williams, J.-P., B. T. Greenhagen, D. A. Paige, N. Schorghofer, E. Sefton-Nash, P. O. Hayne, P. G. Lucey, M. A. Siegler, and K.-Michael Aye (2019), Seasonal polar temperatures on the Moon, *J. Geophys. Res.*, 124, 2505–2521. URL: http://luna1.diviner.ucla.edu/~jpierre/diviner/level4_polar/additional_maps/
- [6] Hamill, B., “Human Landing System Lunar Thermal Analysis Guidebook,” NASA Human Lander System, August 4, 2021, URL: <https://ntrs.nasa.gov/>
- [7] Roberts, B. C., “Cross Program Design Specification for Natural Environments (DSNE)”, National Aeronautics and Space Administration, May 8, 2019, URL: <https://ntrs.nasa.gov/>