



PLIF for Space Technology and Exploration Applications

Neil S. Rodrigues¹

Paul M. Danehy¹, Olivia K. Tyrrell¹, Naibo Jiang², Paul Hsu², Brian R. Hollis¹, Ashley M. Korzun¹, Sukesh Roy²

¹NASA Langley Research Center, ²Spectral Energies, LLC

Acknowledgements

- **NASA Space Technology Mission Directorate (STMD):**
 - Game Changing Development (GCD) program *Entry Systems Modeling*
 - Technology Demonstration Missions (TMD) program *LOFTID*
 - Game Changing Development (GCD) program *Plume Surface Interaction*
- **Spectral Energies LLC supported by Phase I/II/II-E/III Small Business Innovation Research (SBIR) awards in collaboration of STMD and Aeronautics Research Mission Directorate (ARMD)**
- **Conference travel supported in-part by NASA Langley Research Directorate (RD)**
- **Support and contributions of many co-workers is gratefully acknowledged:**
 - NASA Langley: H. Ripley, Dr. J. Retter, Dr. R. Burns, Dr. T. Fahringer, M. Cagle, Dr. T. West, M. Hughes, K. Berger, L. Kuster, A. Robbins, J. Crider, Facility Technicians
 - NASA Marshall: S. Harris, Dr. M. Mehta, Dr. C. Eberhart, K. McDougall, Dr. J. West, Dr. A. Weaver, T. Shurtz, T. Reynolds, T. Liu, Dr. J. Sisco, K. Miasek, K. Thompson, Facility Technicians
 - NASA Ames: Dr. J. Haskins and Dr. A. Brandis
 - Spectral Energies: Dr. Jason Leicht and Dr. Michael Slipchenko

PLIF Measurements at NASA Langley

- **Primary motivation for Planar Laser-induced Fluorescence (PLIF) measurements at NASA Langley:**
 - Provide deeper understanding of flow physics (e.g., flow separation, laminar/turbulent transition)
 - Provide data for validation of CFD codes
 - Provide ground test data that can be used to engineer better flight vehicles
- **Among various kinds of PLIF at NASA Langley, flow visualization using seeded Nitric Oxide (NO-PLIF) most common for Space Technology and Exploration applications**
 - Often low-density flows; NO-PLIF works very well at low gas densities
 - PLIF molecular tagging velocimetry most common quantitative PLIF variant
 - Multi-parameter spectroscopic measurements an active area of research
- **Typical repetition-rate of 10 Hz (flashlamp Nd:YAG pumped dye laser system)**
 - High-speed PLIF measurements an active area of research

Previous PLIF at NASA Langley

- PLIF used at NASA Langley since mid-2000s (Paul Danehy & co-workers)

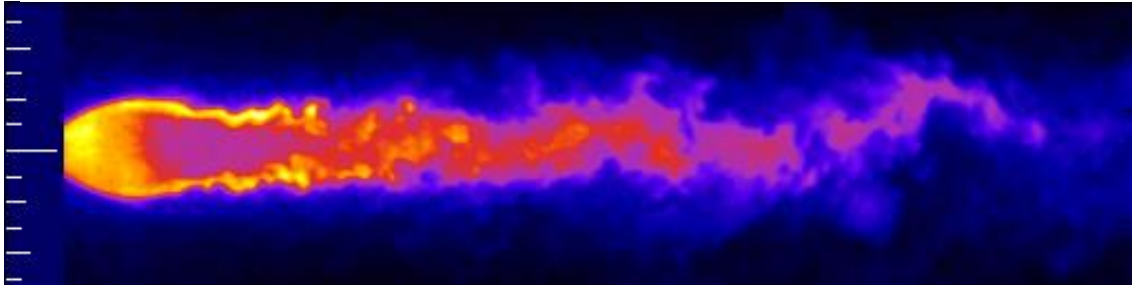

Turbulent underexpanded jet with premixed NO/N₂ injected into a quiescent environment
(Wilkes *et al.*, AIAA Paper 2009-591)

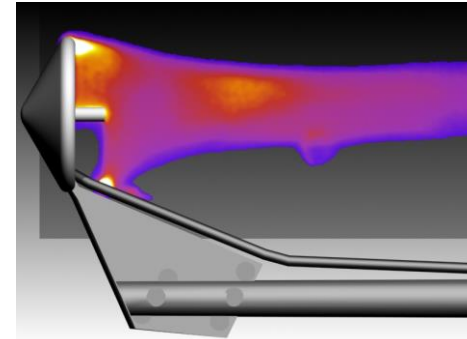

Local seeding of pure NO within the wake of a Mach 10 freestream
(Alderfer *et al.*, AIAA Paper 2007-1063)

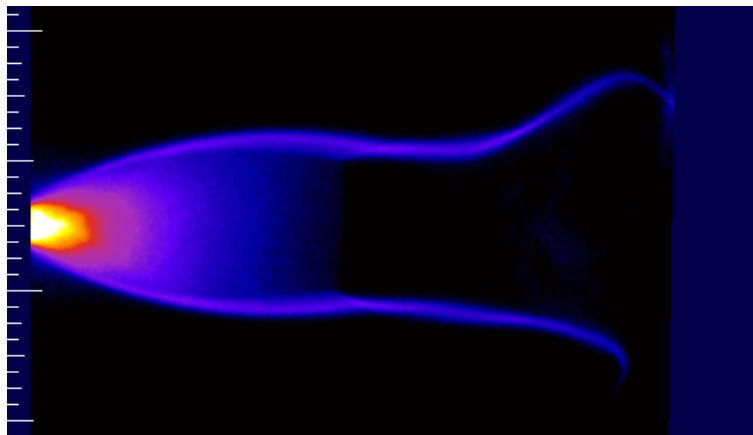

Laminar underexpanded jet with premixed NO/N₂ impinging on wall
(Wilkes *et al.*, AIAA Paper 2008-619)

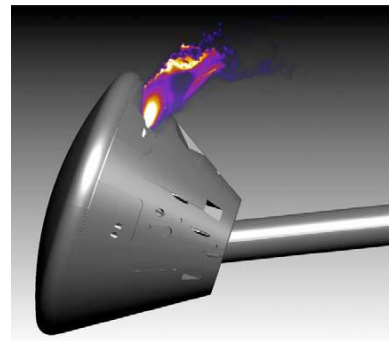

Underexpanded jet with premixed NO/N₂ injected into a Mach 10 crossflow
(Danehy *et al.*, AIAA Paper 2008-123)

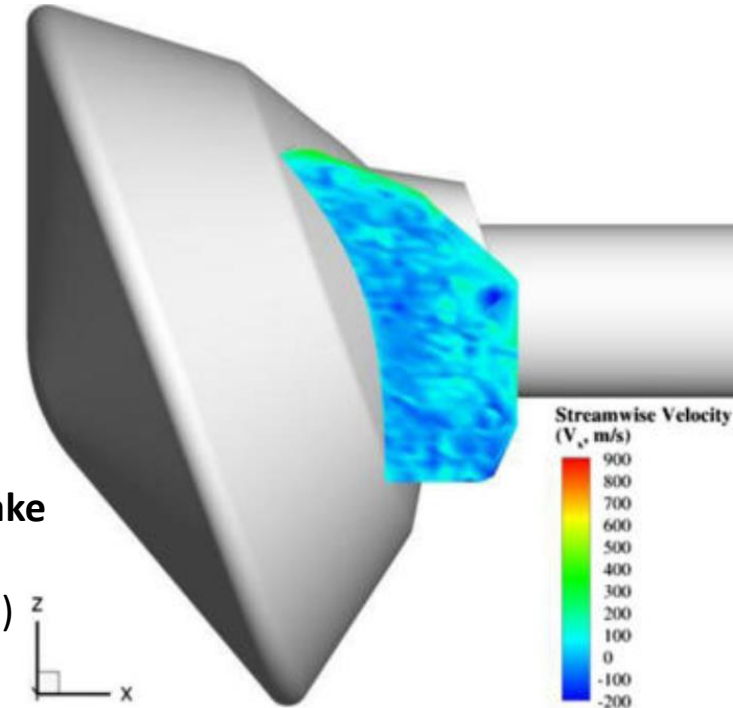

PLIF molecular tagging velocimetry in wake of Mars Science Laboratory model
(Johansen *et al.*, AIAA Journal of Spacecraft and Rockets, 2013)

Recent PLIF Applications

**NO-PLIF within 31-in Mach 10 Tunnel
at NASA Langley Research Center (LaRC)**



***Entry Systems Modeling* project:**

- Investigate hypersonic wakes of blunt bodies for Terrestrial and Martian planetary entry

**NO-PLIF within 20-ft Vacuum Chamber
at NASA Marshall Space Flight Center (MSFC)**



***Plume Surface Interaction* project:**

- Investigate plume impingement flow behavior for lunar and Martian landings

Planar Laser-induced Fluorescence

- **2D, temporally and spatially-resolved technique**
 - Spatial resolution < 1 mm
 - Temporal resolution < 1 μ s
 - Repetition-rate of 10 Hz typical
- **PLIF of seeded nitric oxide (NO) ideal for low-pressure environments**
 - Spectroscopic and chemical properties of NO are well known
 - UV excitation wavelength accessible with commercial lasers
 - UV fluorescence detectable with commercial intensified cameras
- **PLIF signal generally scales with gas density (signal intensity is qualitative)**
 - Location of flow structures (e.g., shocks) is quantitative
 - Molecular tagging methods can be used for velocity
 - Spectroscopy can be exploited for thermodynamic properties

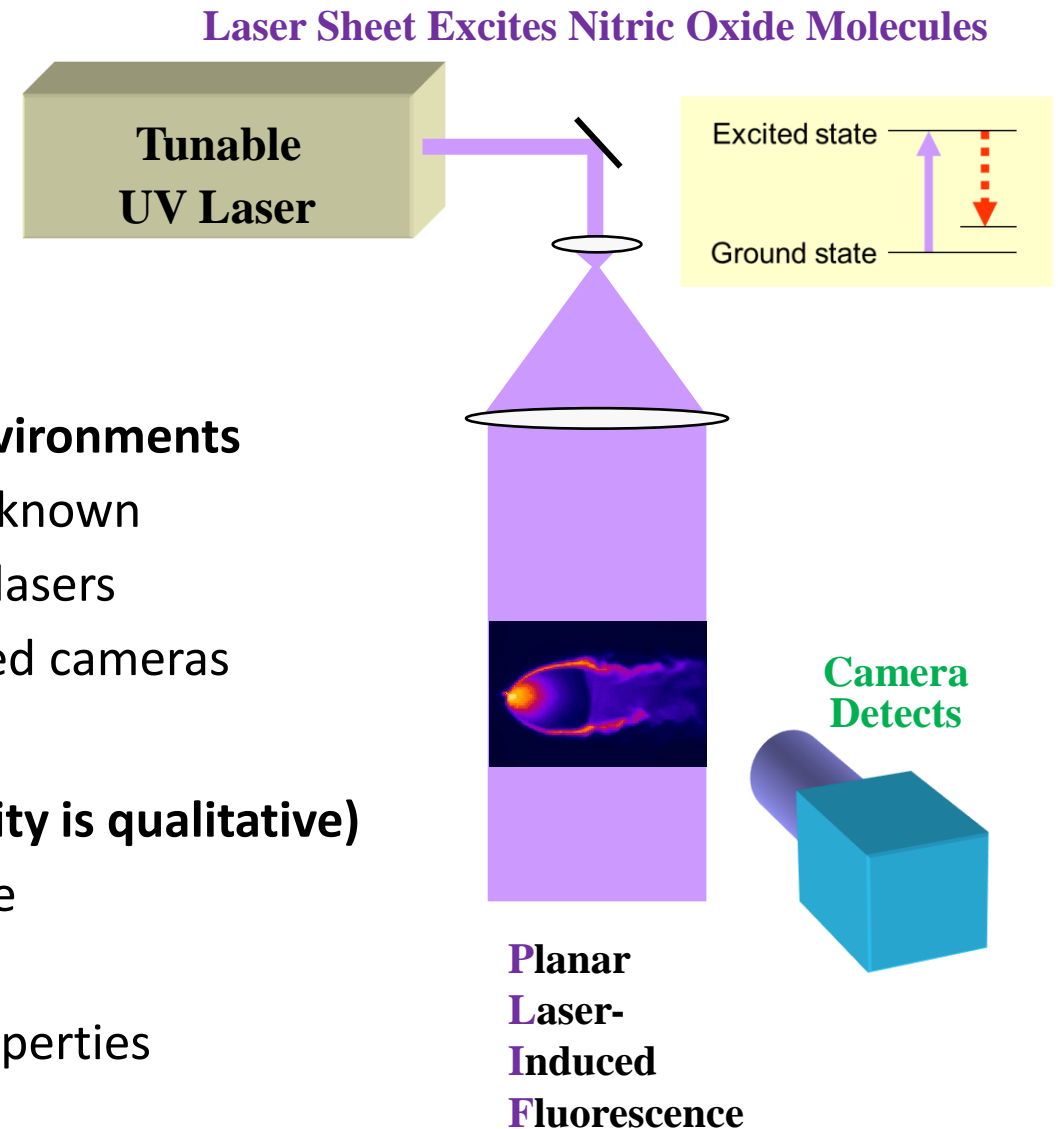



Hypersonic Wakeflow

Hypersonic Wakeflow

- Driven by emerging **Hypersonic Inflatable Aerodynamic Decelerator (HIAD)** technology:
 - Effective, mass-saving alternative to conventional aerodynamic decelerators
 - Terrestrial (Earth) and Mars applications: recovery/reuse of launch vehicles, large mass payloads
 - IRVE-3 (suborbital): **I**nflatable **R**e-entry **V**ehicle **E**xperiment (2012)
 - LOFTID: **L**ow-Earth **O**rbit **F**light **T**est of an **I**nflatable Decelerator (2022)
- **Large regions of separated hypersonic wakes are computationally challenging for simulations**
 - Unsteady flows require 3D, time-accurate calculations
 - Lower gas densities (approaching rarefied) in wake compared to forebody

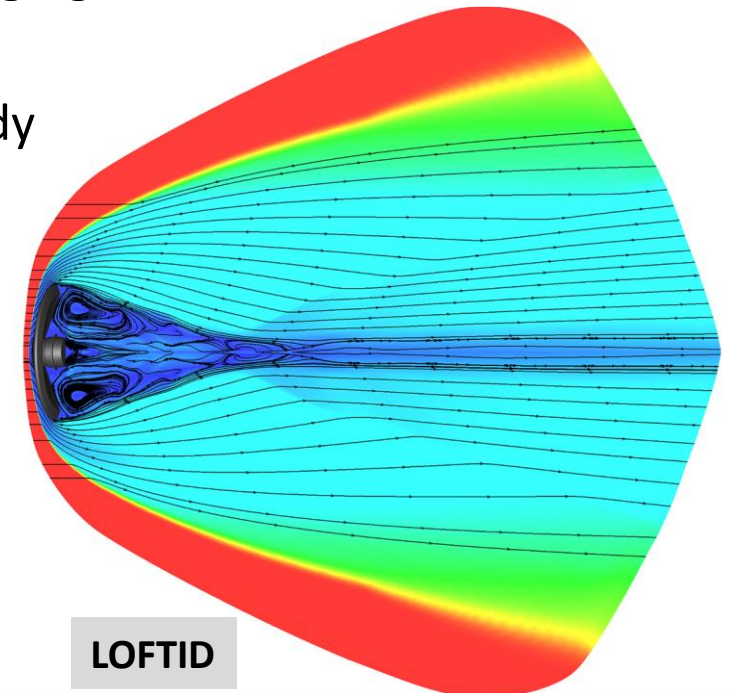
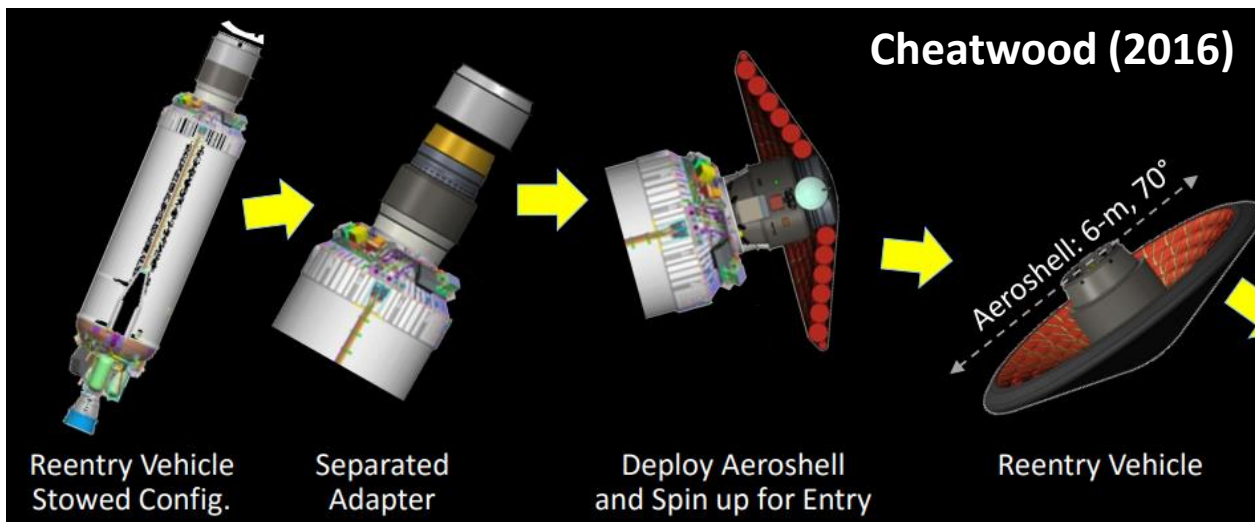

Wind Tunnel Model

- 70-deg sphere-cone forebody, smooth aft-body, blade-style sting

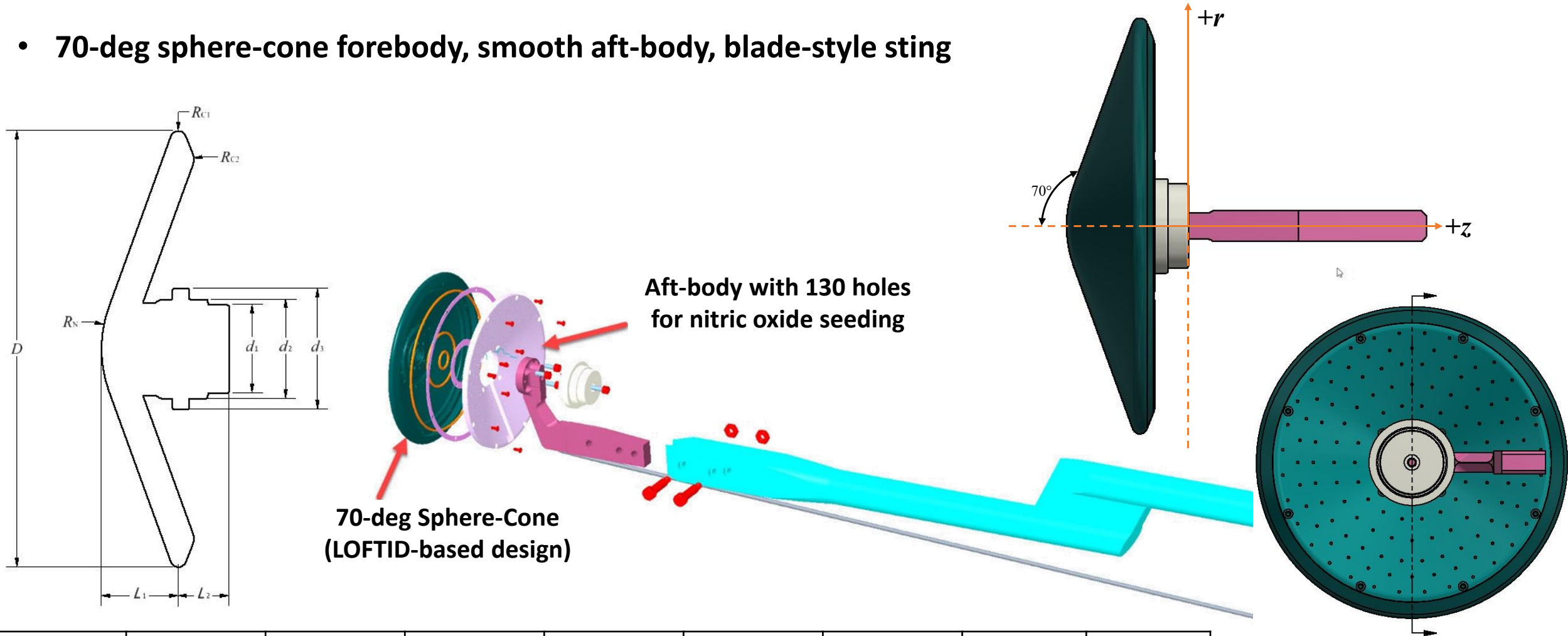

D	d_1	d_2	d_3	L_1	L_2	R_N	R_{C1}	R_{C2}
127 mm	25.7 mm	29.0 mm	35.1 mm	22.4 mm	14.8 mm	36.1 mm	2.3 mm	4.4 mm

31-inch Mach 10 Air Tunnel

- **Blowdown wind tunnel**
- **Optical access on 3 sides**
 - 4th side model injection
- **3 typical unit Reynolds numbers**
 - $Re_{\infty}/L = 1.8 \cdot 10^6 \text{ m}^{-1}$
 - $Re_{\infty}/L = 3.6 \cdot 10^6 \text{ m}^{-1}$
 - $Re_{\infty}/L = 6.3 \cdot 10^6 \text{ m}^{-1}$

M_{∞} [-]	9.69	9.82	9.95
Re_{∞}/L [m^{-1}]	$1.79 \cdot 10^6$	$3.57 \cdot 10^6$	$6.33 \cdot 10^6$
T_0 [K]	966	965	961
T_{∞} [K]	50.9	49.7	48.6
P_0 [MPa]	2.41	4.97	9.00
P_{∞} [Pa]	68.4	130.1	220.2
u_{∞} [m/s]	1385	1386	1385

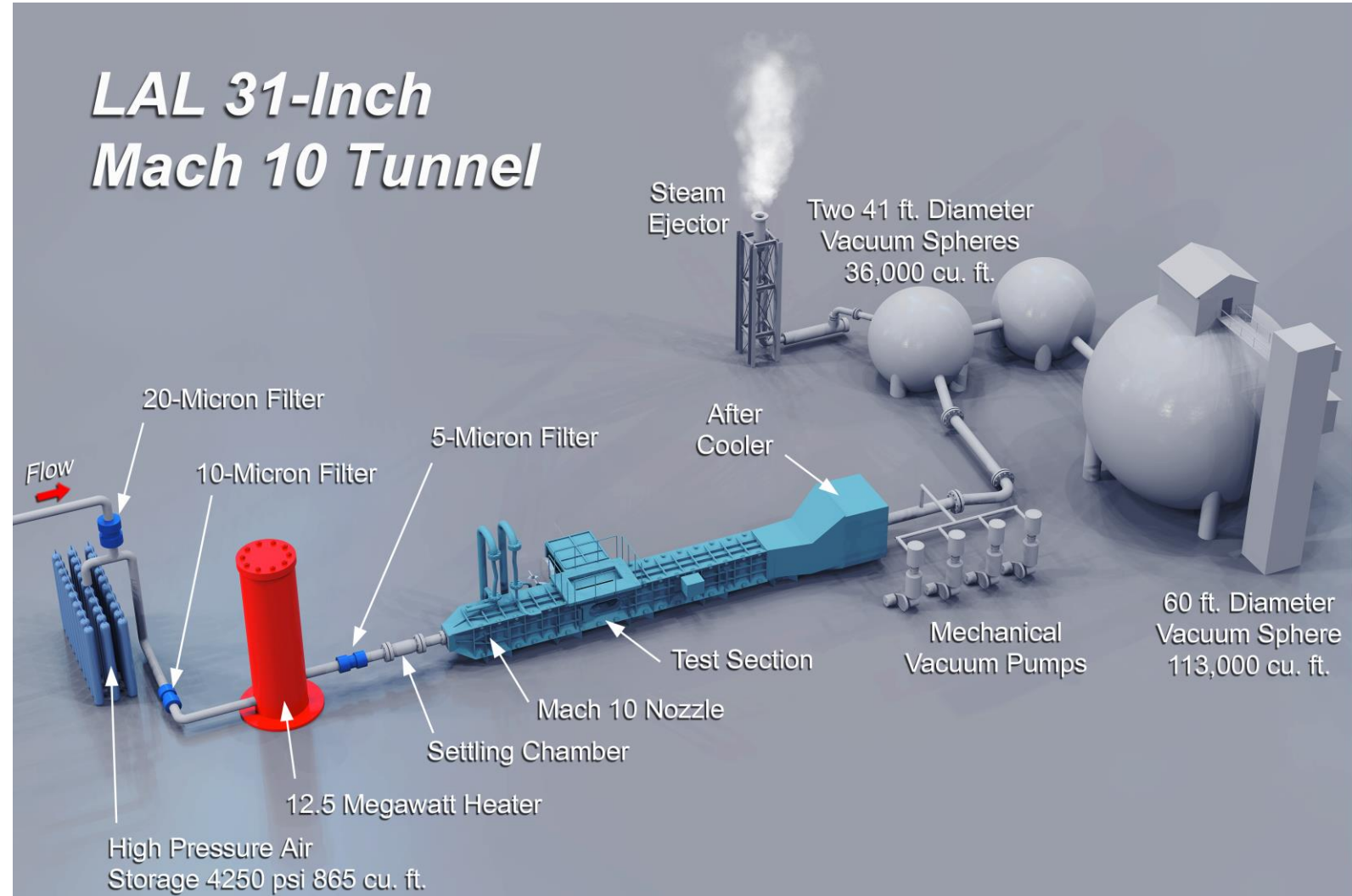

PLIF Set-Up Overview

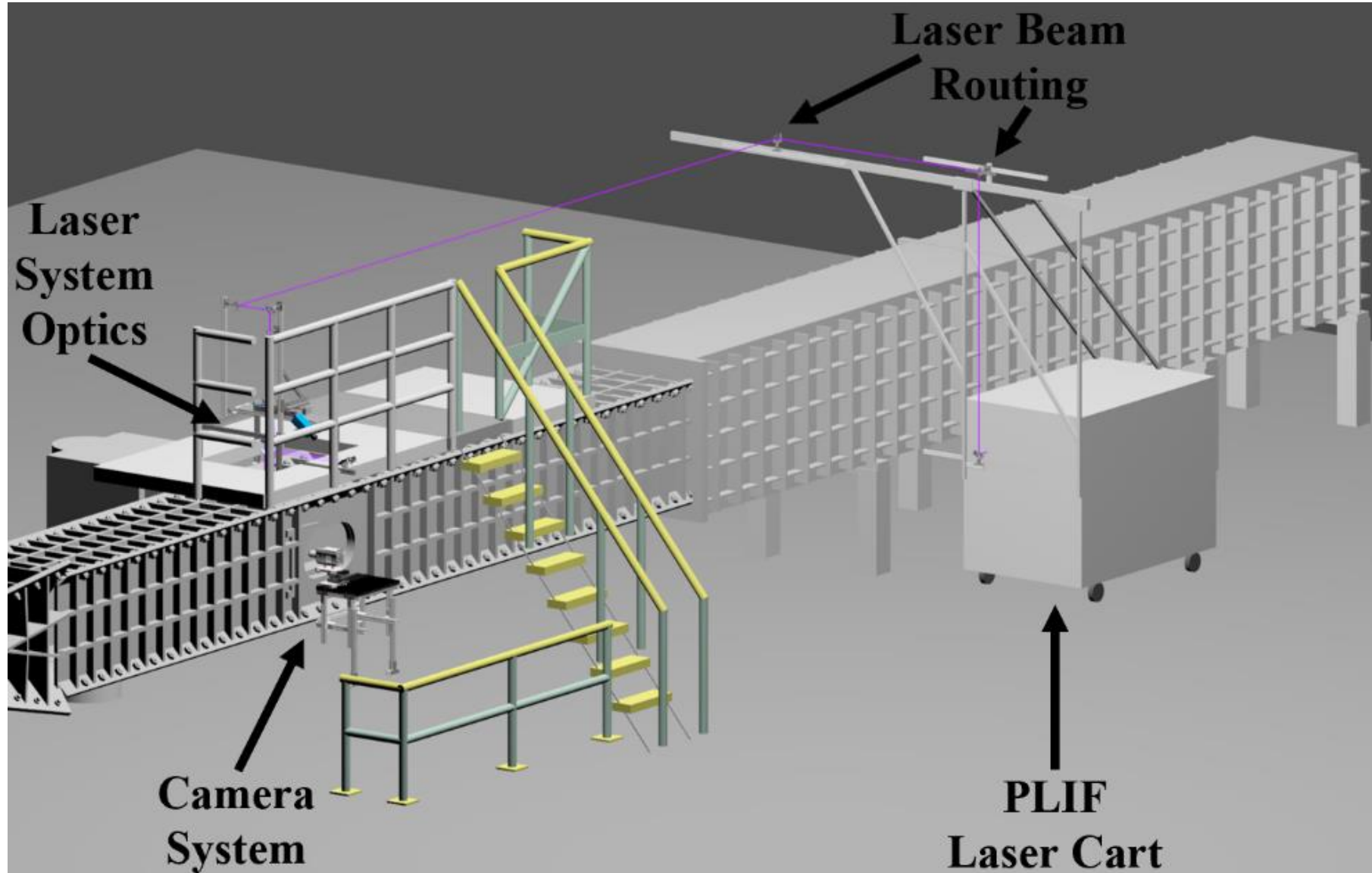

PLIF Systems at Test Section

- 226 nm laser enters wind tunnel through top window
 - Cylindrical and spherical lenses used to create 2D laser sheet from laser beam
 - ~150 mm wide and <1 mm thick at model centerline
- Intensified sCMOS camera images from side window (230 – 300 nm fluorescence wavelengths)
 - 0.5 μ s exposure for each image
- Reference CCD camera mounted on top of tunnel used to monitor laser sheet energy distributions
 - Blue fluorescence from glass diffuser plate

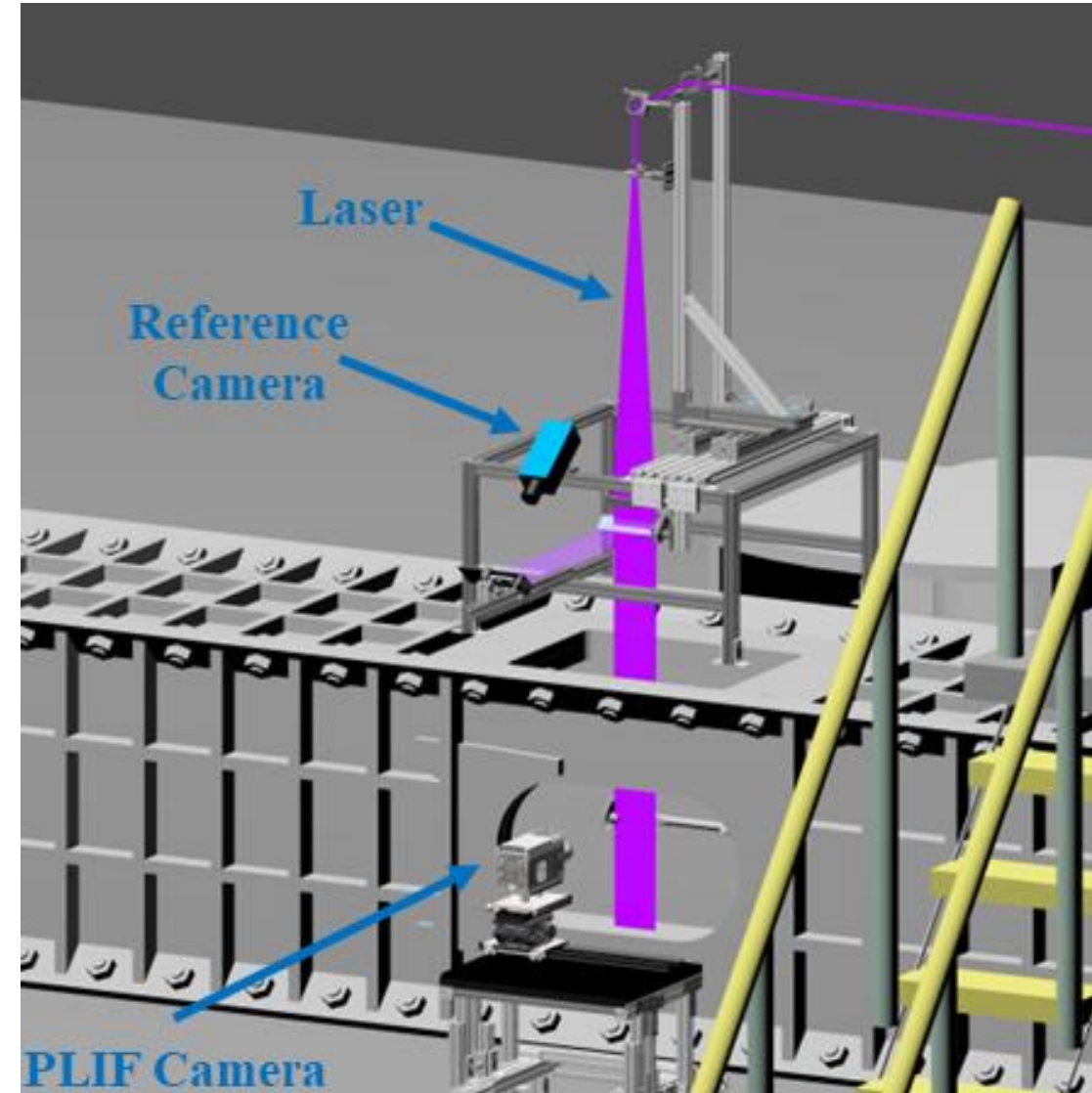

PLIF Flow Visualization: Re_∞/L effect

$Re_\infty/L = 1.8 \cdot 10^6 \text{ m}^{-1}$

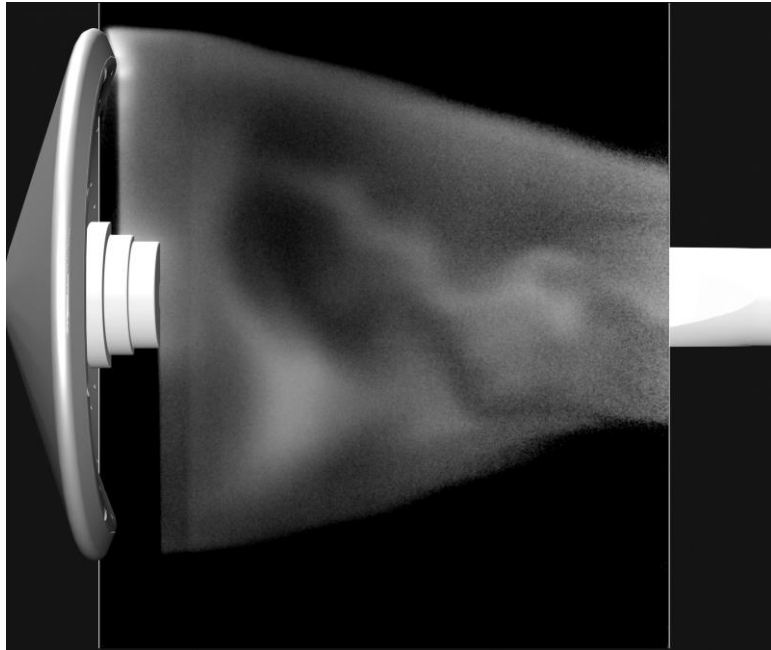

$Re_\infty/L = 3.6 \cdot 10^6 \text{ m}^{-1}$

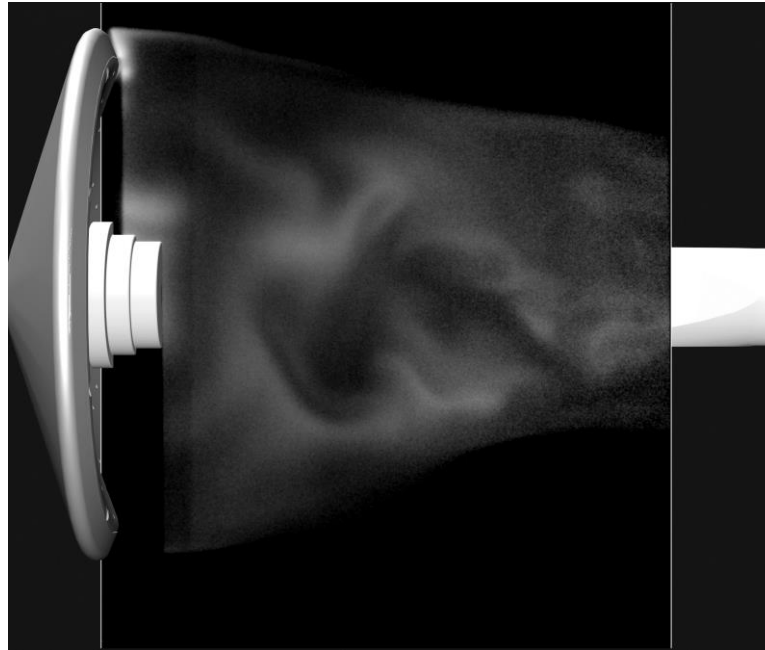

$Re_\infty/L = 6.3 \cdot 10^6 \text{ m}^{-1}$

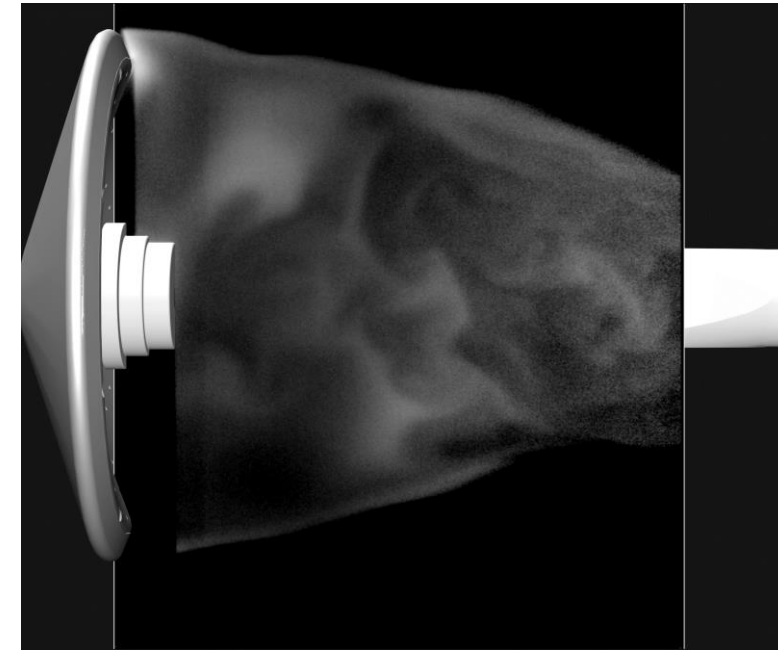

AoA = 0°

- Flow is unsteady for all three Reynolds number conditions ($\sim 3.5x$ factor in Re_∞/L)
 - Large-scale structures present throughout (arguably smaller structures for higher Re_∞/L)
- PLIF signal intensity visualized in logarithmic grayscale to preserve flow structures while minimizing large signal variation near the model due to varying NO gas concentrations
- Additional results in 2024 NASA Technical Memorandum (Rodrigues *et al.*)

Time-averaged, Planar Temperature

Laser Wavelength [nm]	Transition
226.9356	$P_{12}(3.5)$
226.1391	$R_2(13.5)$

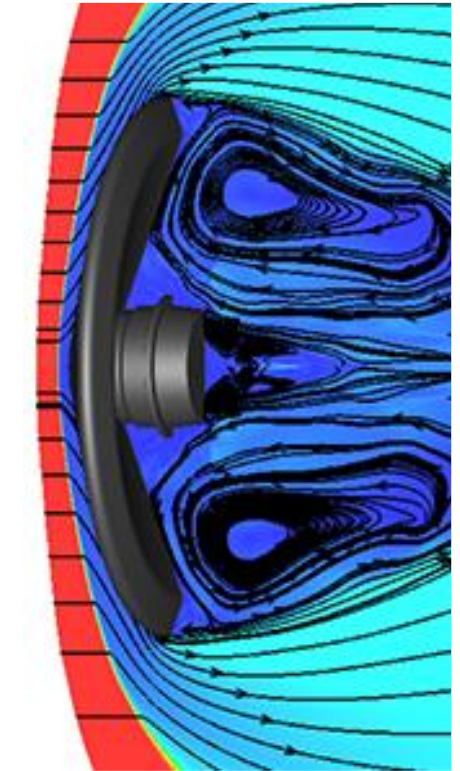
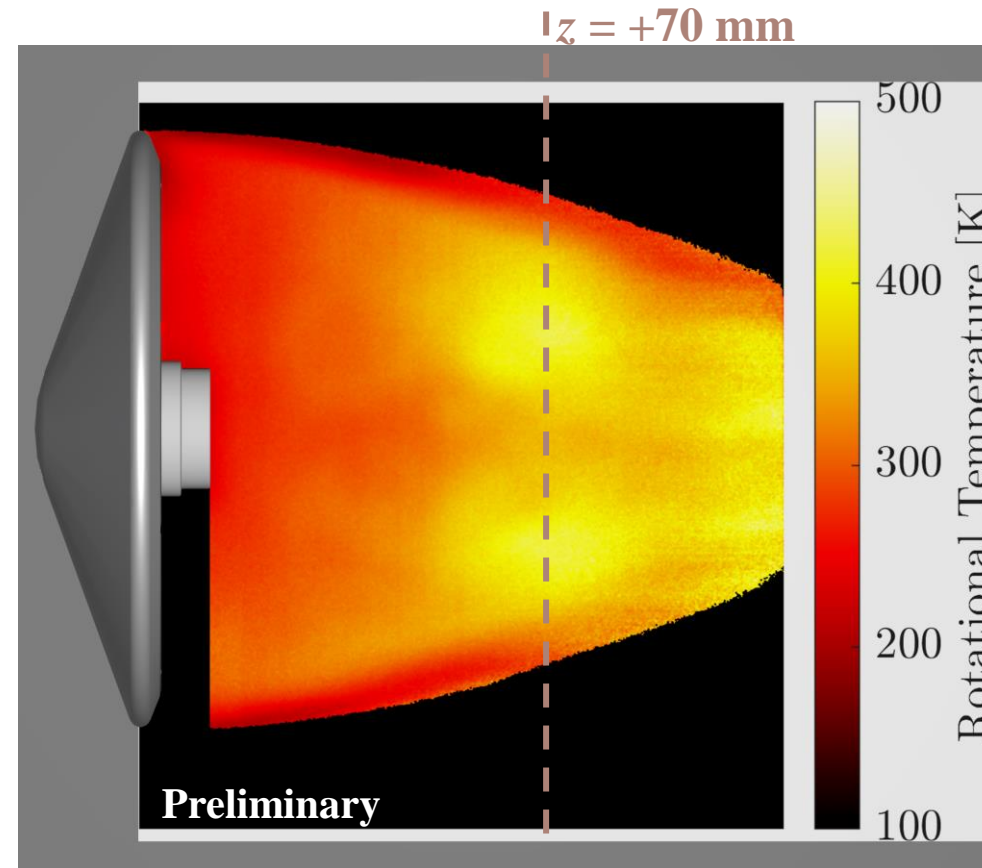
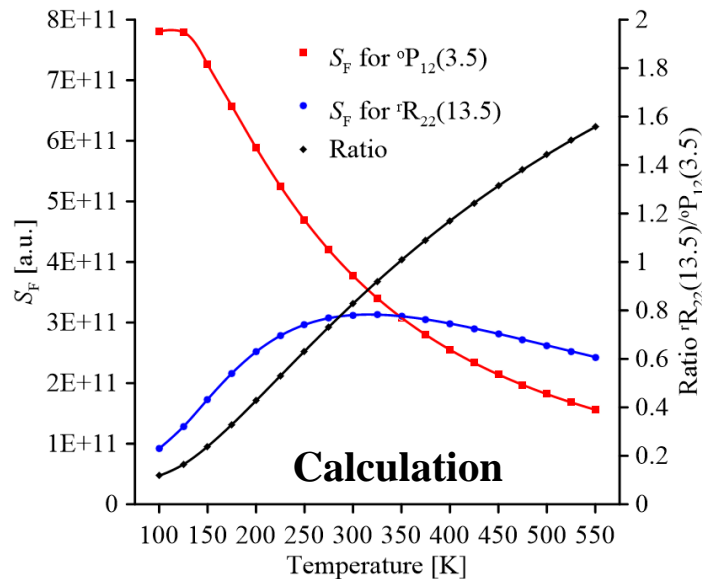

- **Time-averaged 2D temperature estimated using two different laser wavelengths over 2 tunnel runs**
 - Fluorescence from two different laser wavelengths have different temperature sensitivity
 - Vortex pair potentially revealed from the 2D temperature map
 - Upcoming effort: extend to instantaneous temperature measurements using two-laser PLIF system

NO-PLIF Molecular Tagging Velocimetry

- **1D DOE (Diffractive Optical Element) used to create 75 laser beamlets from a single laser beam**
 - 3x improvement in spatial extent compared to previous work such as Bathel *et al.* (2011)
- **Velocity determined based on measurement displacement of PLIF signal and known Δt**
 - 2 images acquired ~ 500 ns apart: $u = \Delta x / \Delta t$
- **Additional details in 2024 AIAA SciTech Paper (Rodrigues *et al.*)**

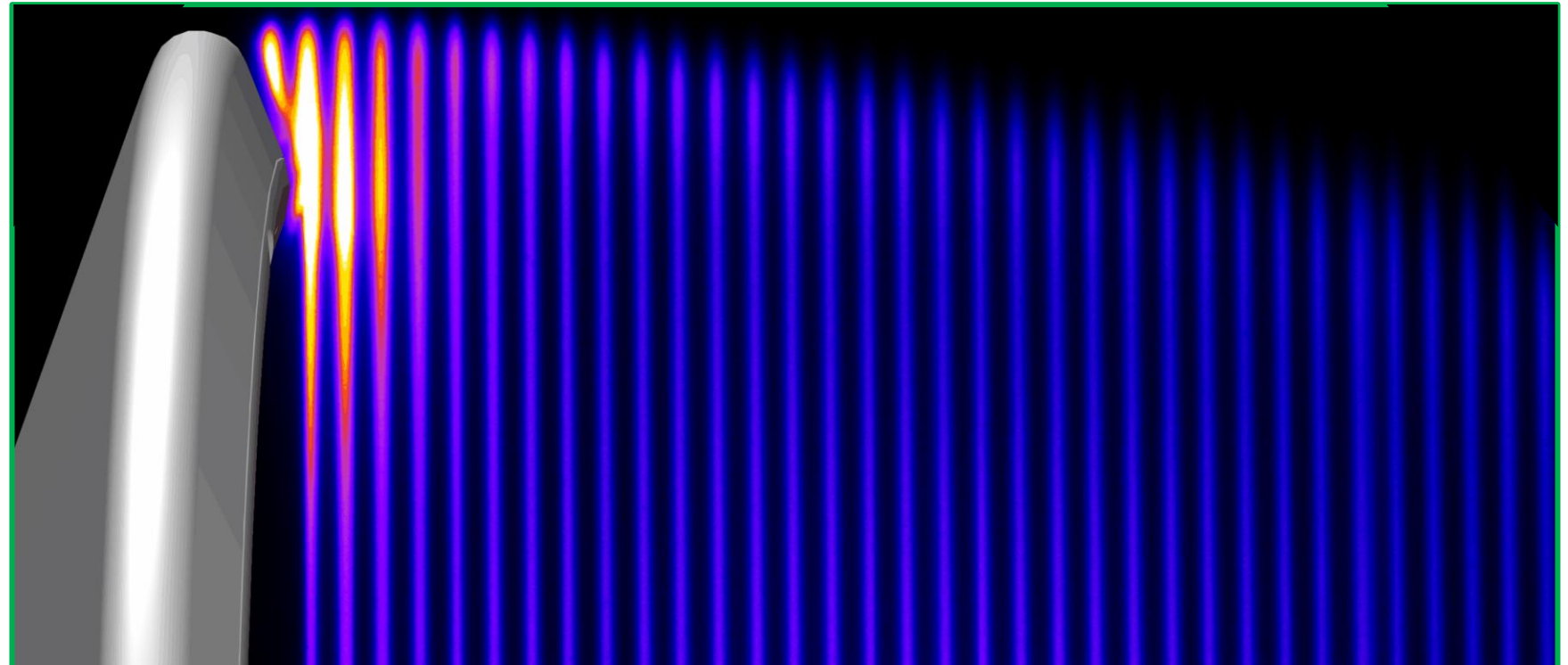
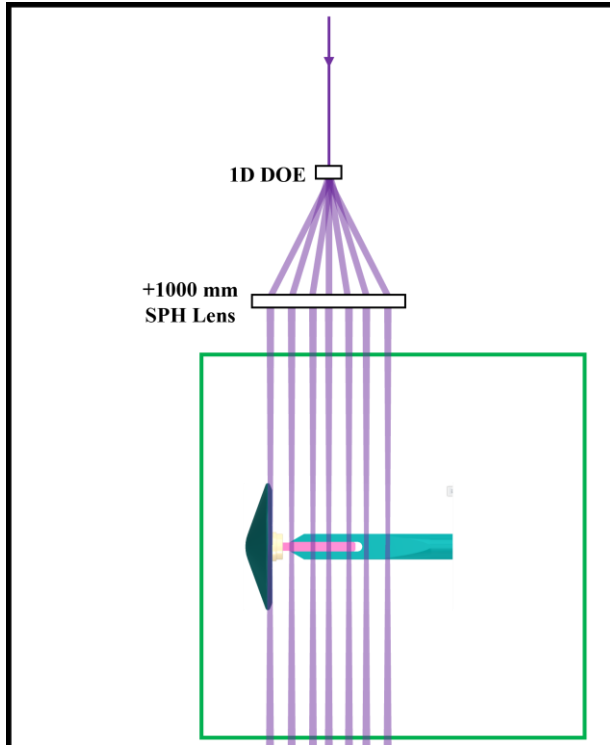

Time-averaged, Planar Z-Direction Velocity

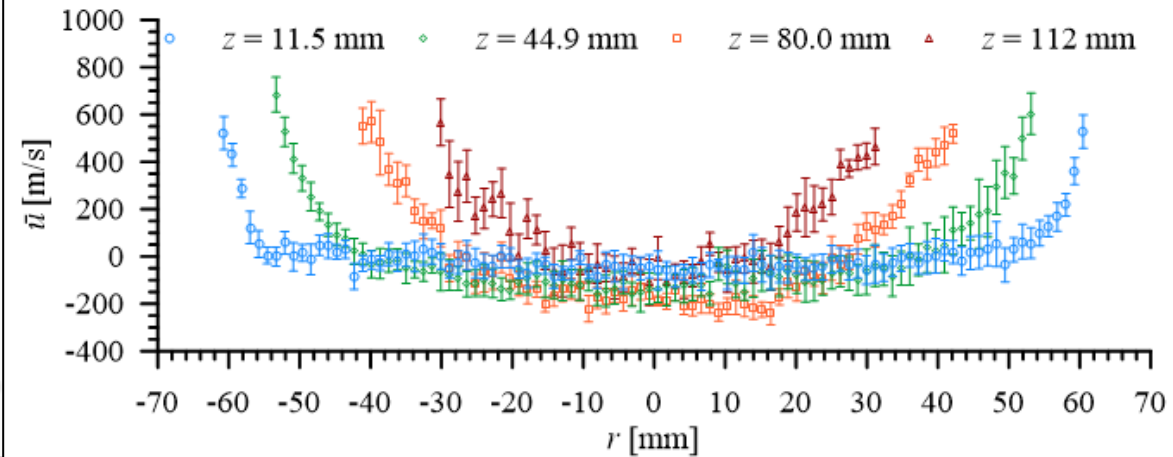
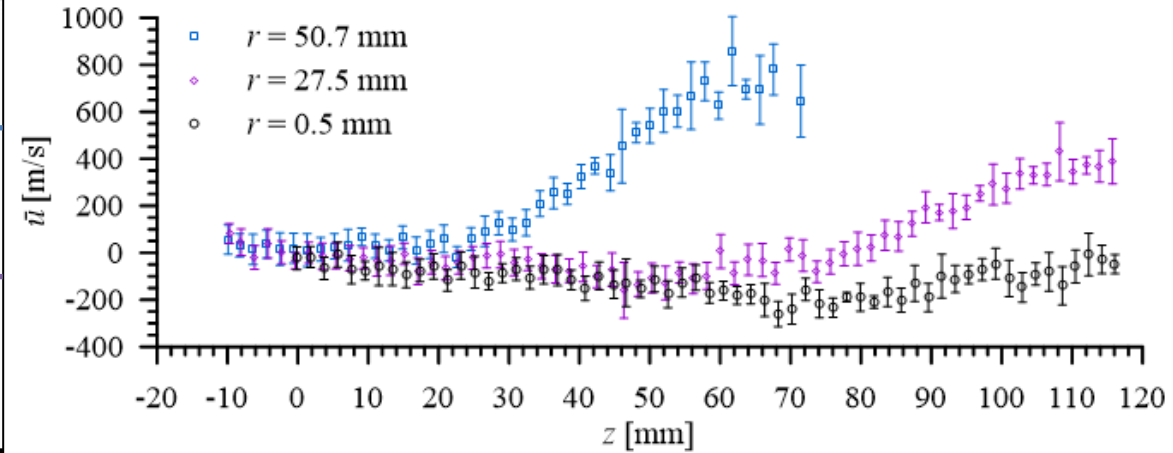
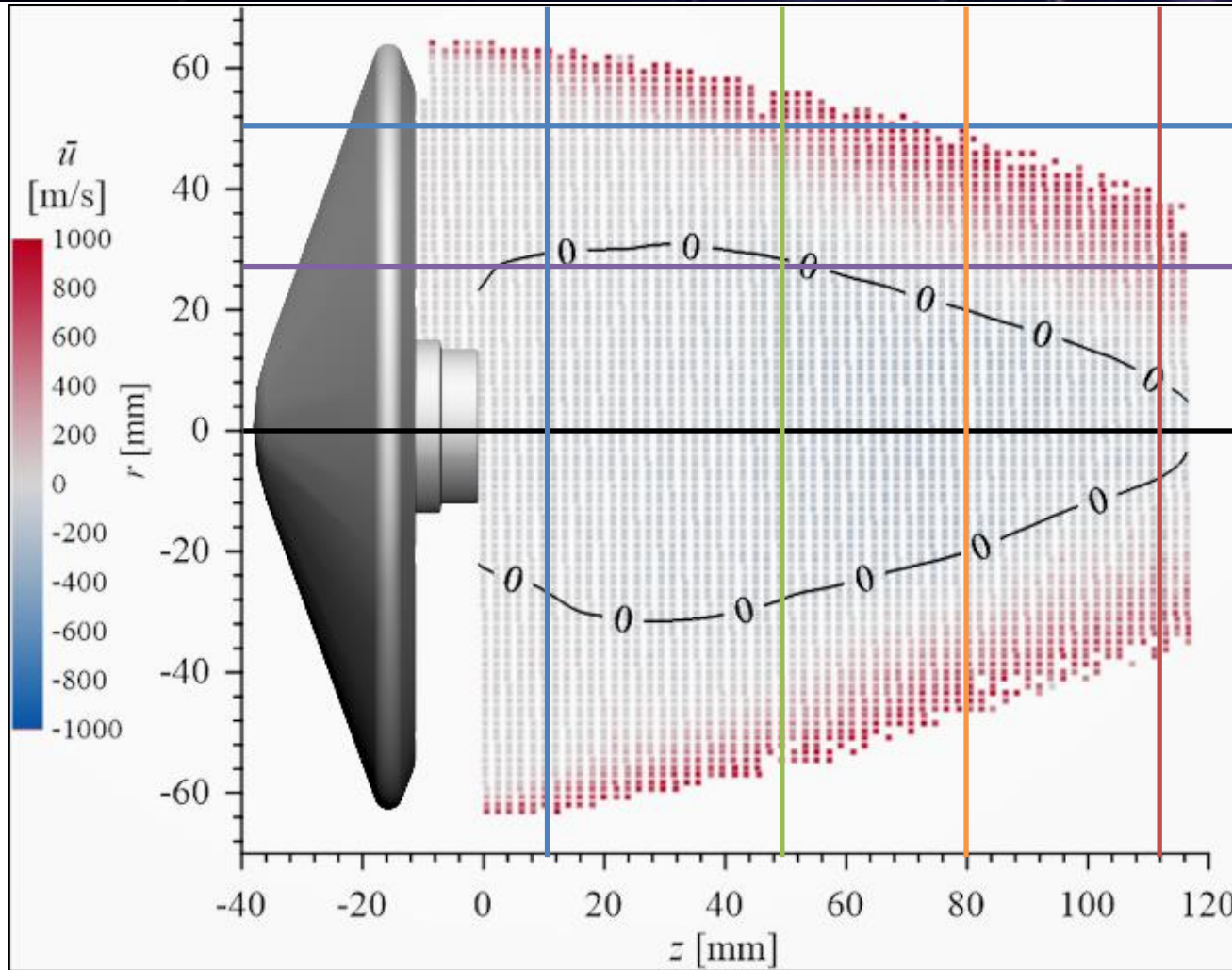

- **High-velocity shear layer, reverse flow, stagnation regions**
 - Estimated zero-velocity line for z-direction velocity shown on velocity color map

Instantaneous, Planar Z-Direction Velocity

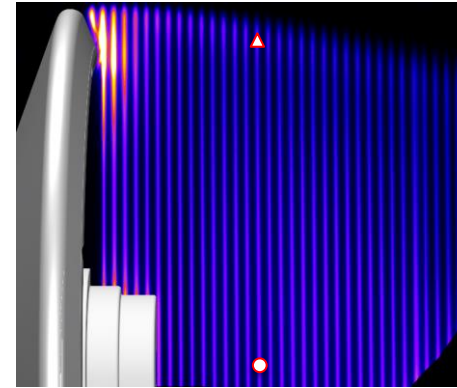
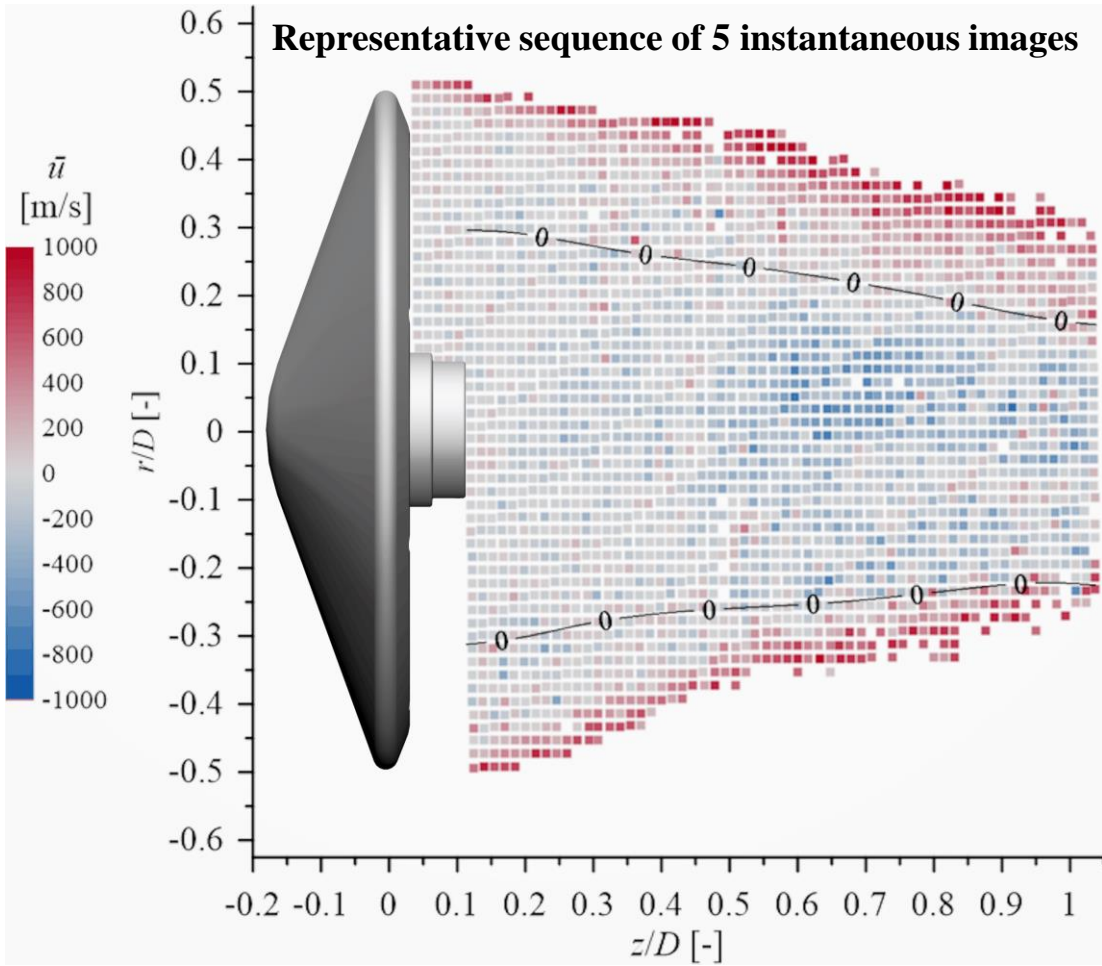

Data from line 19 mm downstream of payload

$r/D = 0, z/D = 0.26$

$\mu = -64$ m/s

$\sigma = 81$ m/s

$2\sigma/\sqrt{N} = 9$ m/s

$r/D = 0.46, z/D = 0.26$

$\mu = 288$ m/s

$\sigma = 125$ m/s

$2\sigma/\sqrt{N} = 14$ m/s

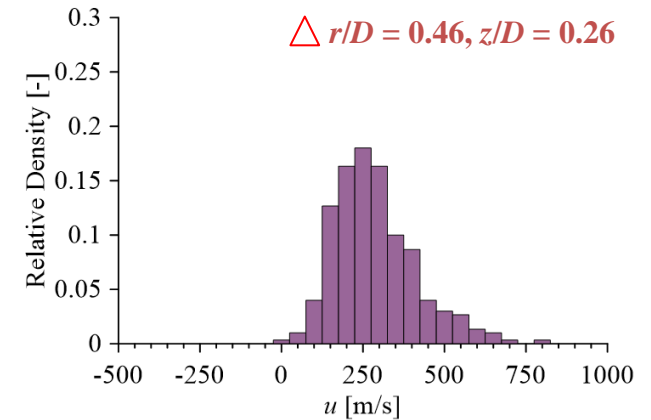
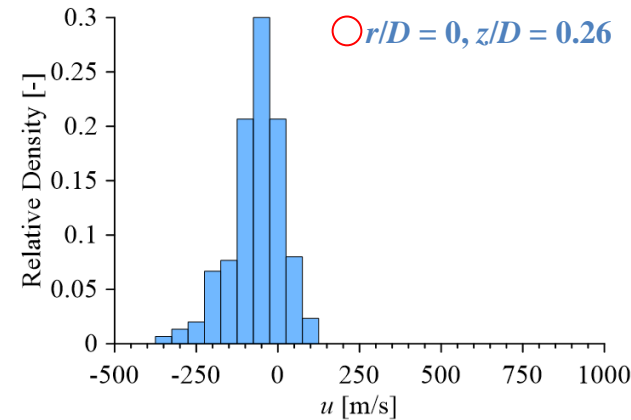

- **Instantaneous z-direction (streamwise) velocity: u and u' statistics for unsteady CFD comparison**
- Upcoming effort: extend to 2-component planar velocity using two-laser PLIF system



Plume-Surface Interaction

Plume-Surface Interaction

- **Rocket Plume-Surface Interaction (PSI):**
 - Induced environment due to impingement of hot rocket exhaust on landing surface
 - Complex: multi-scale and often multi-phase (unimproved Lunar or Martian surface)
 - Realistic environments: plumes within reduced ambient pressures (continuum to rarefied scales)
- **Driven by risks associated with spacecraft landings on extraterrestrial environments**
- **2022 Ground Test of Supersonic Plume Impingement at NASA Marshall 20-ft Vacuum Chamber**



Lunar Landings: Apollo program → Artemis missions



Martian: rover landings → human landings

Plume Impingement Test Article

- **Mach 5.3 supersonic nozzle:**
 - Heated N_2 seeded with NO
 - Exit Diameter $D_e = 1.38$ cm
- **Nozzle vertically translated:**
 - $h/D_e = 10$ to 2
- **3 of 10 Flow Conditions:**
 - Case A: Highest P_0 , Martian P_a
 - Case B: Highest P_0 , Lunar P_a
 - Case C: Lowest P_0 , Lunar P_a

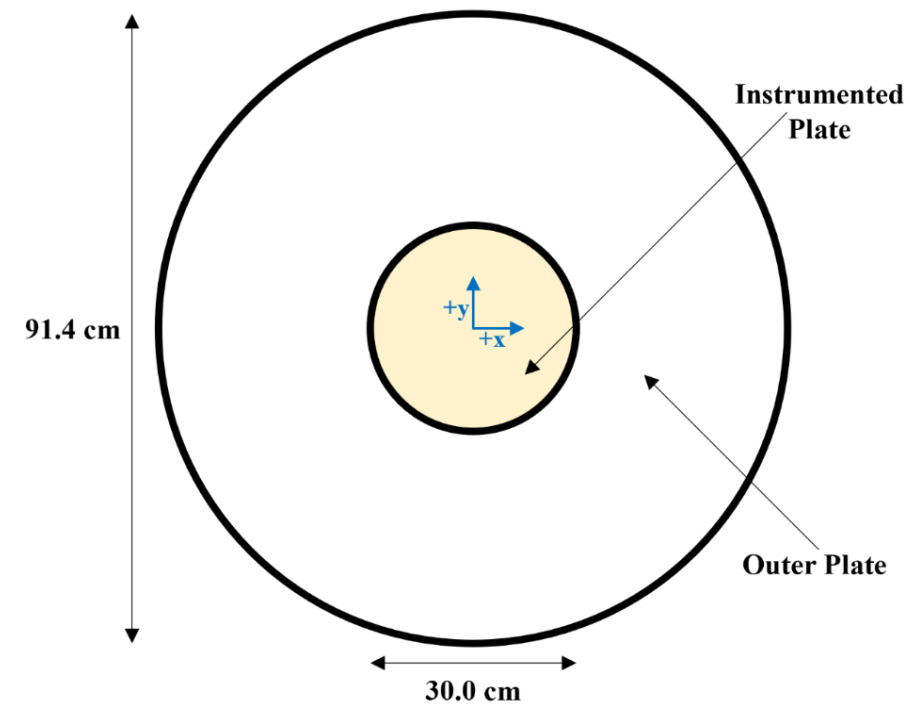
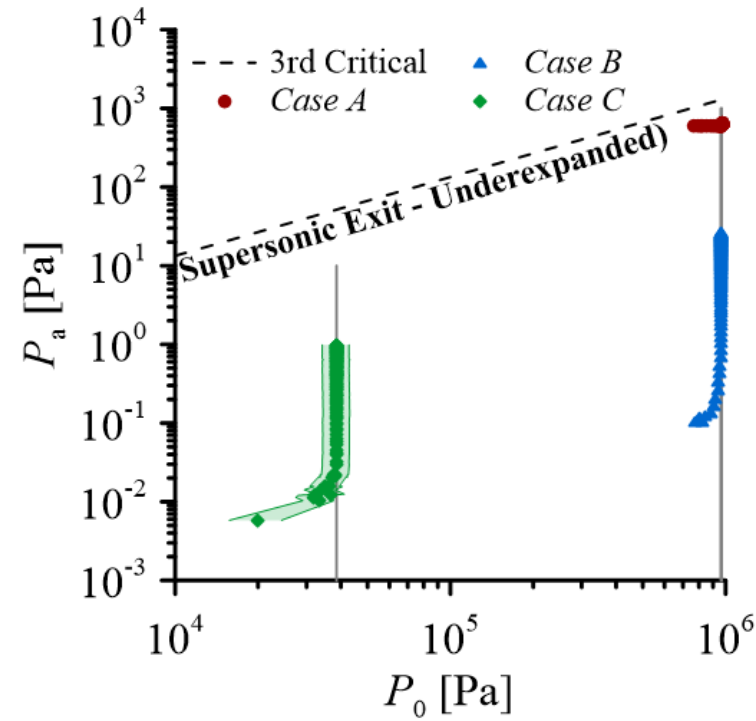
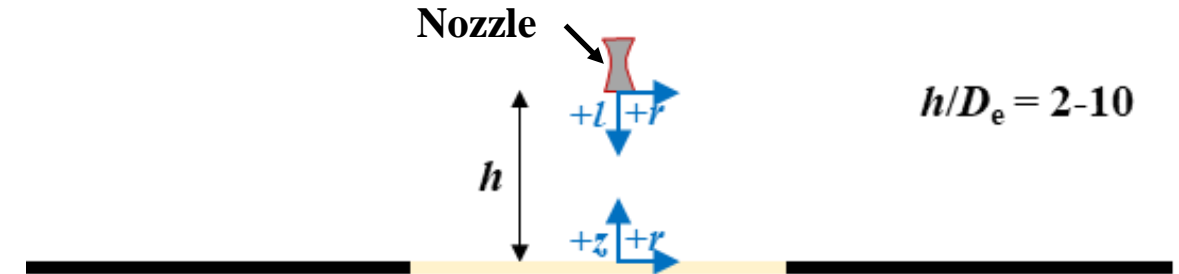

20-ft Vacuum Chamber Overview

- **Plume impingement test article located near middle of chamber**
- **UV laser (near 226 nm) brought into vacuum chamber through viewport window**
- **Optics for PLIF laser sheet placed on custom structure inside chamber**
 - Laser beam alignment adjusted using remote-controlled mirrors
 - Laser sheet expanded to ~ 140 mm; < 1 mm thickness near nozzle
- **PLIF cameras located within custom camera enclosures inside chamber**
 - Intensified sCMOS (PLIF)
 - CCD (Laser sheet monitoring)

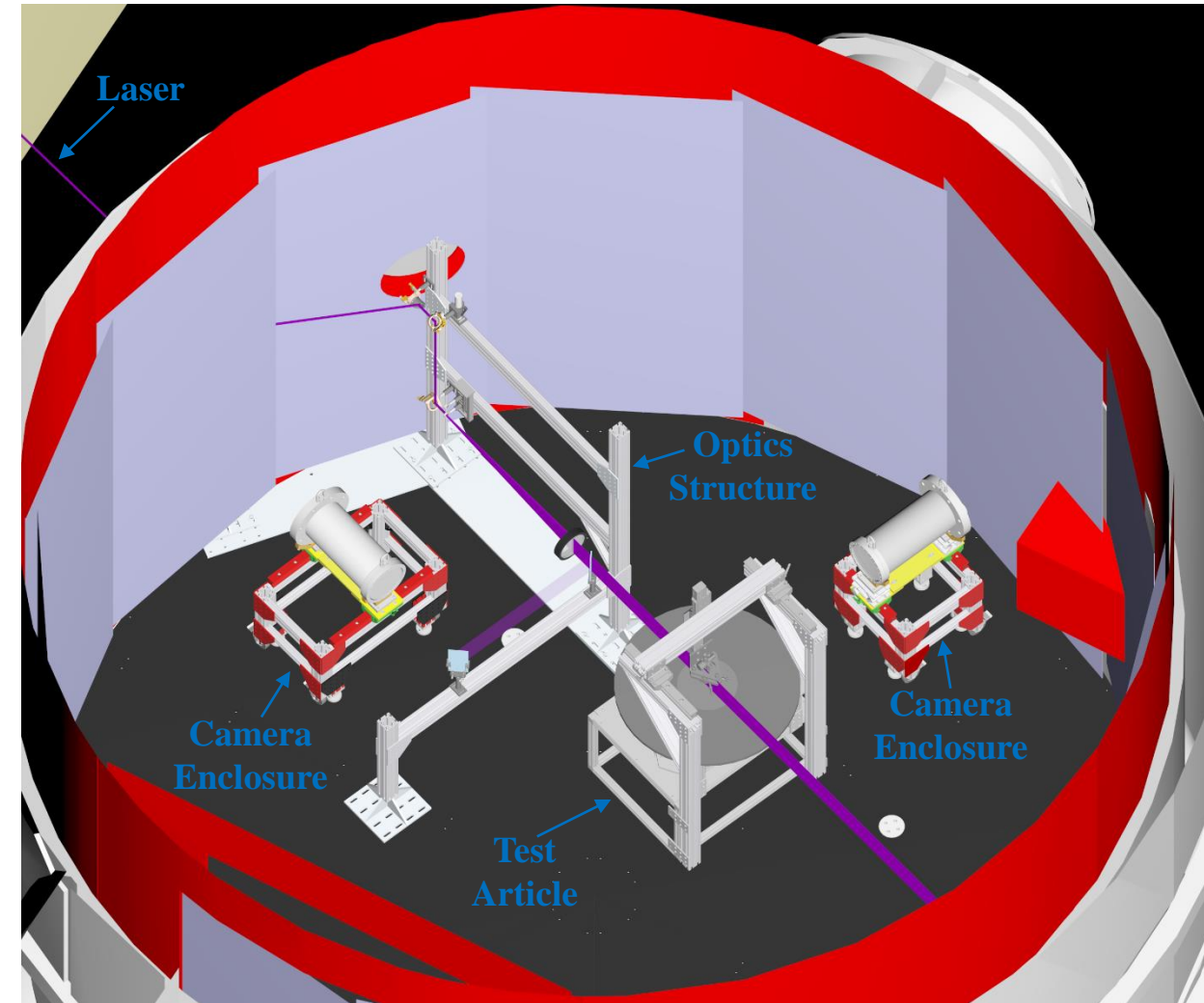

PLIF Flow Visualization at $h/D_e = 10$

- Case A: Highest P_0 , Martian P_a

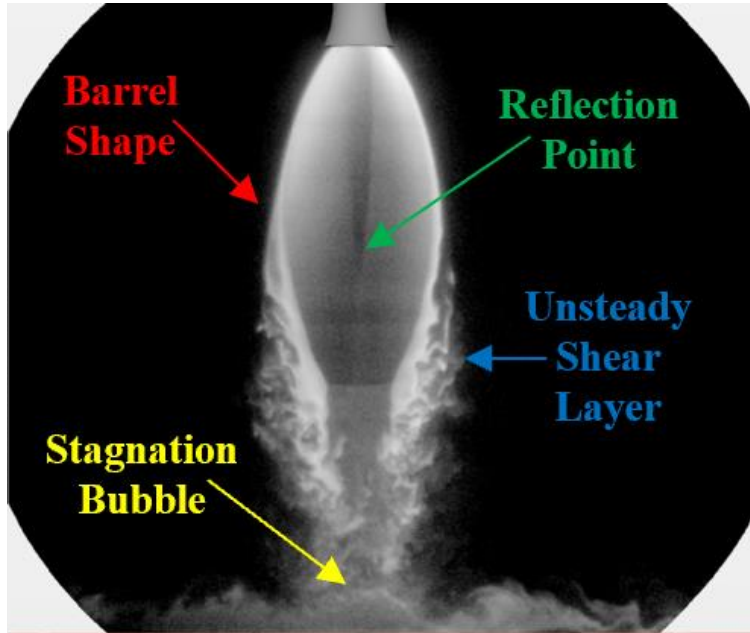

- Measure location of:
 - Nozzle Reflection Point
 - Mach Disk Position
 - Stagnation Bubble Height

- Case B: Highest P_0 , Lunar P_a

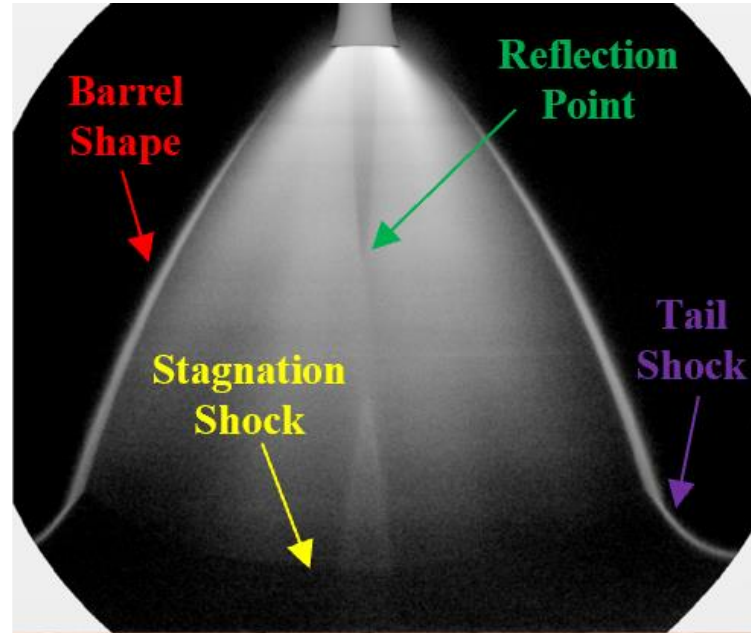

- Measure location of:
 - Nozzle Reflection Point
 - Radial Extent of Jet
 - Stagnation Shock Height

- Case C: Lowest P_0 , Lunar P_a

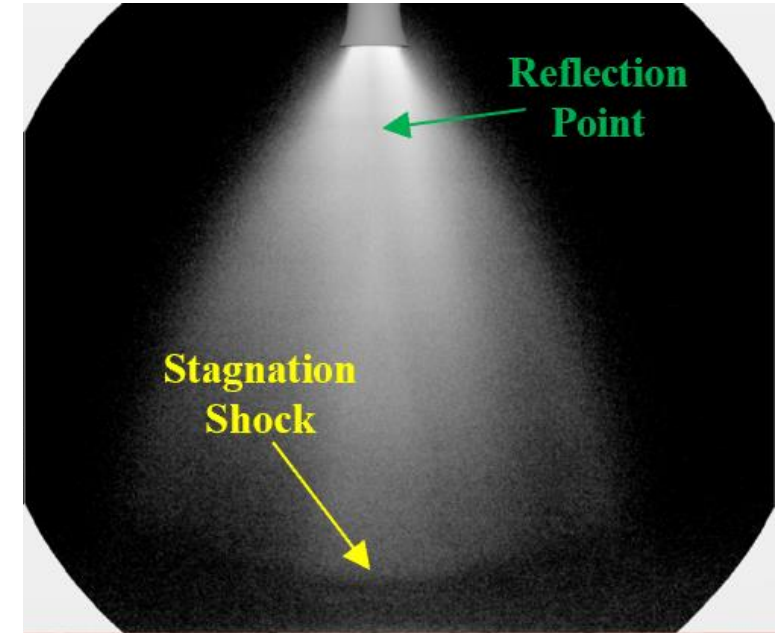

- Measure location of:
 - Nozzle Reflection Point
 - Radial Extent of Jet
 - Stagnation Shock Height

Results in journal manuscript currently under peer review (Rodrigues, Tyrrell, Danehy)

Plume Impingement Test Data

- **Test data overview (2023 JANNAF paper; Rodrigues *et al.*)**
- **Impingement pressure with time-averaged flow visualization**
 - Impingement structure apparent from pressure data (but not fully resolved)
 - Double peaks and low-pressure suction region
 - Similar to Inman *et al.* pressure measurements
 - May explain annular crater behavior

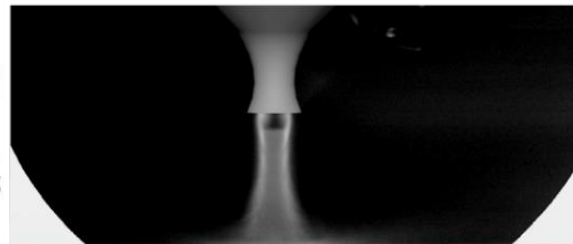
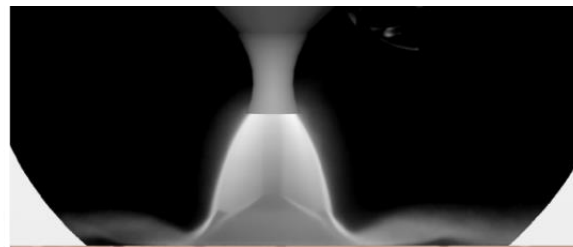
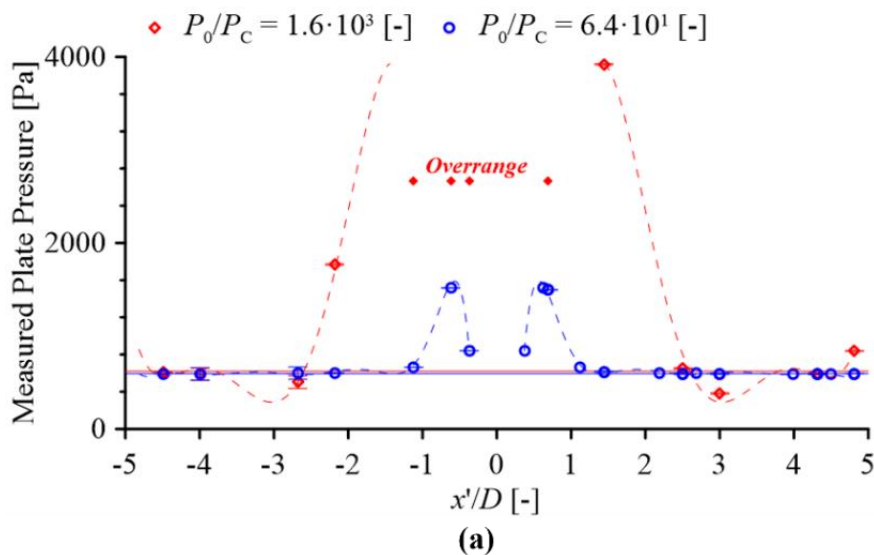

Martian-relevant test data: (a) impingement pressure, (b) highest P_0 , and (c) lowest P_0 .

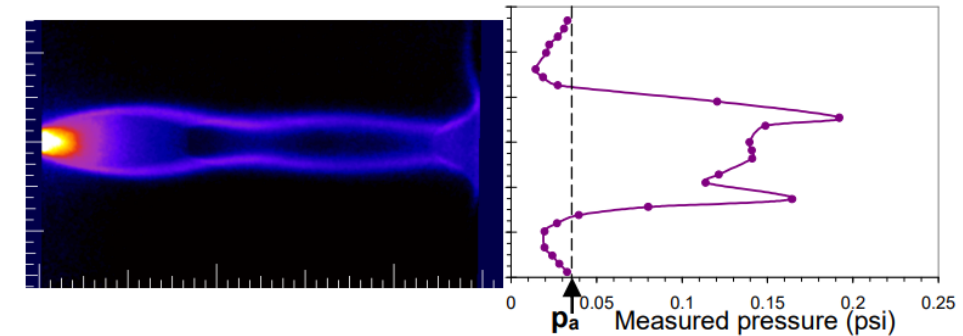

Inman *et al.* (2008)

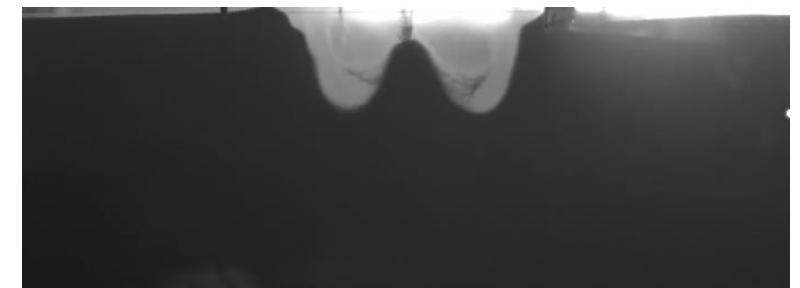

Rubio *et al.* (2023)

Plume Impingement Test Data

- Test data overview (2023 JANNAF paper; Rodrigues *et al.*)
- **Effect of geometric configuration (2024 AIAA SciTech paper; Tyrrell *et al.*)**
- **Past experimental PSI work frequently utilized a “half-space” design**
 - Flow bisected with splitter edge (enables erosion and ejecta measurements with single camera)
 - How does this affect plume impingement?

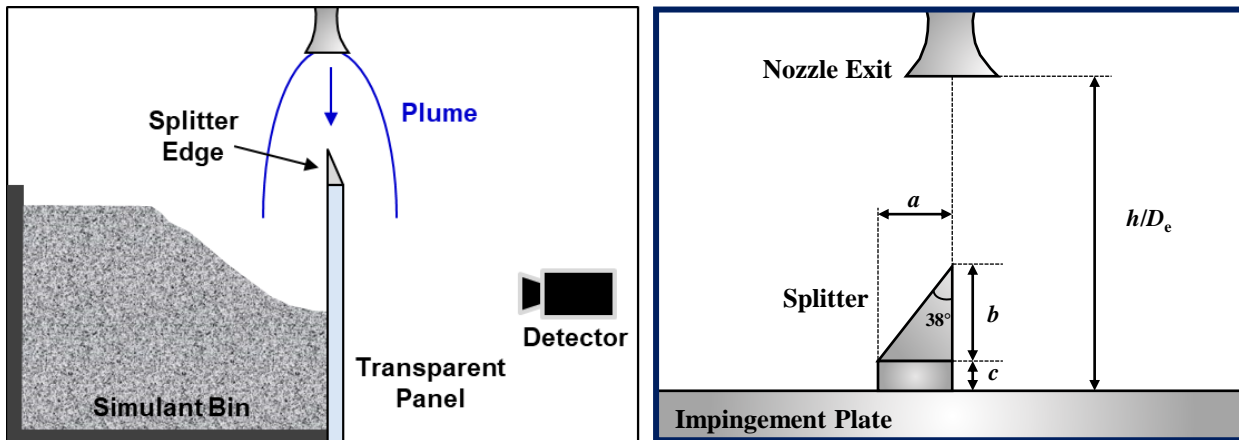

Common “half-space” PSI test design (left) and plume impingement geometric configuration (right)

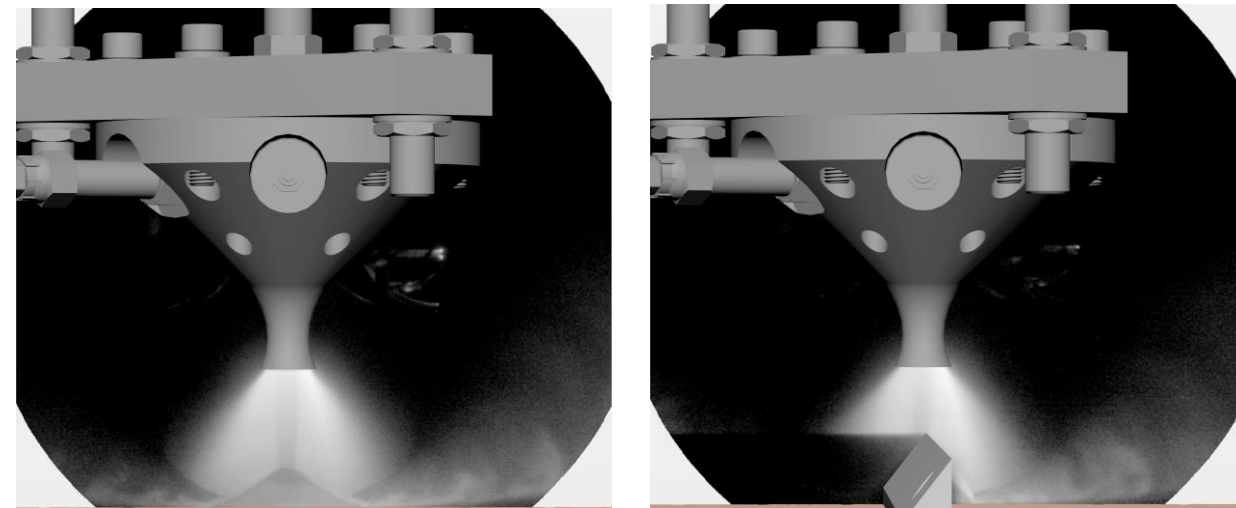

Lunar-relevant test data: full-space design (left) and half-space design (right)

Plume Impingement Test Data

- Test data overview (2023 JANNAF paper; Rodrigues *et al.*)
- Effect of geometric configuration (2024 AIAA SciTech paper; Tyrrell *et al.*)
- Effect of dimensionless altitude h/D_e
 - Martian-relevant conditions (upcoming 2024 AIAA Ascend paper, Rodrigues *et al.*)
 - Lunar-relevant conditions (paper in-preparation, Rodrigues *et al.*)

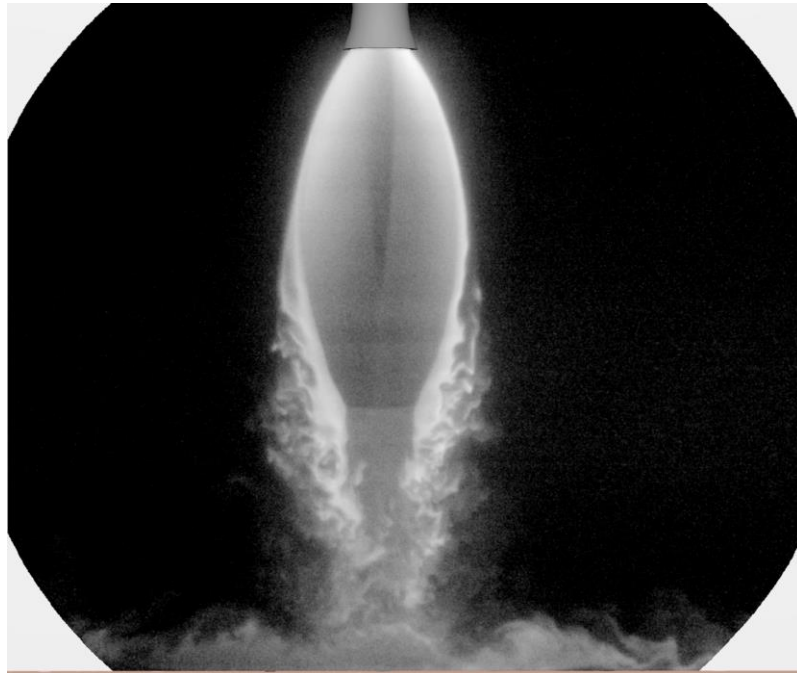

Martian-relevant test data



Lunar-relevant test data

Plume Impingement Test Data

- Test data overview (2023 JANNAF paper; Rodrigues *et al.*)
- Effect of geometric configuration (2024 AIAA SciTech paper; Tyrrell *et al.*)
- Effect of h/D_e
 - Martian-relevant conditions (upcoming 2024 AIAA Ascend paper, Rodrigues *et al.*)
 - Lunar-relevant conditions (paper in-preparation, Rodrigues *et al.*)
- **Spatial-evolution of wall-jet (upcoming 2025 AIAA SciTech paper, Rodrigues *et al.*)**

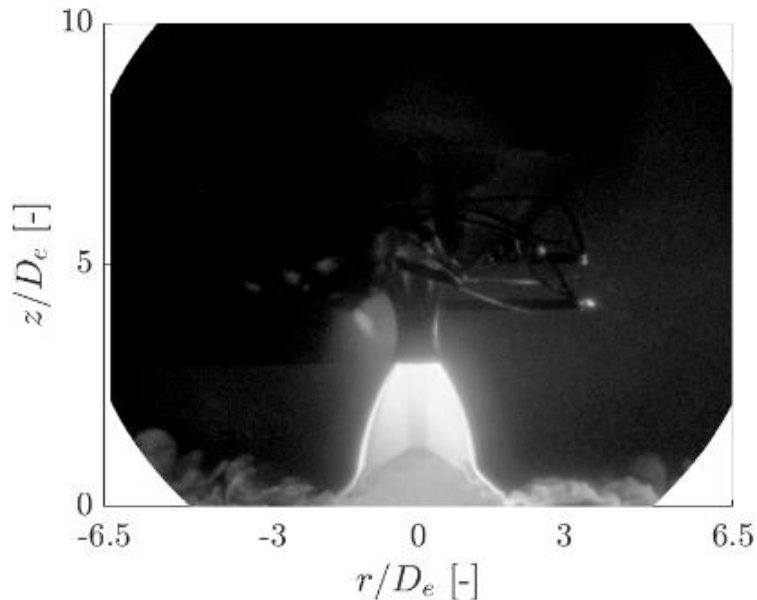

Primary PLIF Camera

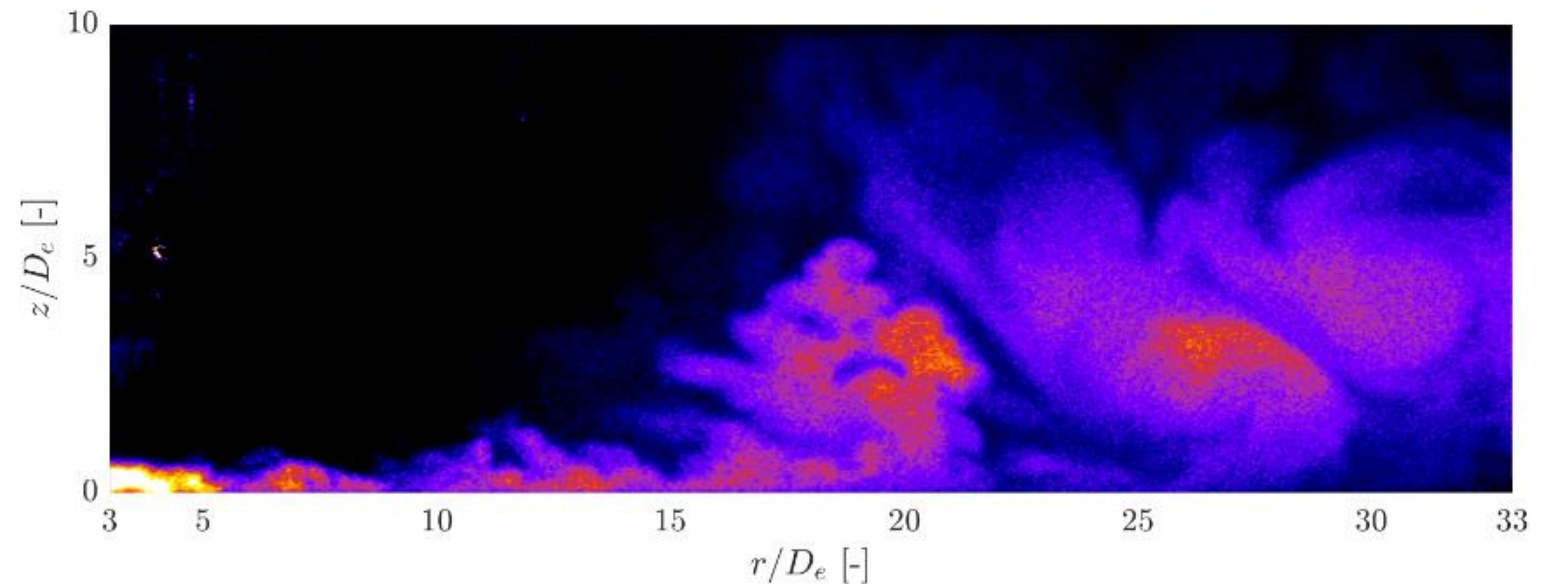

Secondary PLIF Camera

Upcoming PSI Test at NASA Langley

- **Upcoming ground tests, funded by NASA Exploration Systems Development Mission Directorate**
 - 60-ft Vacuum Sphere at NASA Langley (100 Pa target pressure)
 - Designed specifically to reduce PSI risks for HLS program lunar landers
- **OH-PLIF of hot-fire rocket plume planned for Test Entry #2**
 - Hybrid motor: solid fuel, gaseous oxygen
 - Multi-phase flow with lunar soil (regolith) simulant

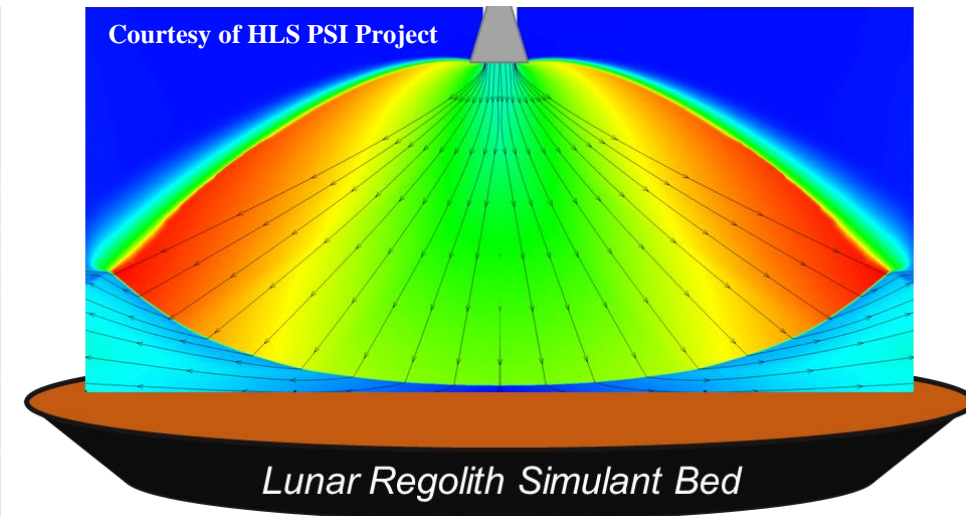



High-Speed PLIF Development

Burst-Mode Laser and OPO

- **Spectral Energies Burst-Mode Laser: CW 1064 nm oscillator with 7 amplifier stages (custom design)**
 - Operated at 100 kHz repetition rate with 2.5 ms burst duration
- **Spectral Energies Burst-Mode Optical Parametric Oscillator (OPO)**
 - Injection-seeded OPO with sum-frequency mixing
- **Commercial high-speed intensified camera system**
- **Function generator used to scan the 1064 nm laser wavelength at 500 Hz**
- **Underexpanded jet system: sonic nozzle with ambient temperature nitrogen seeded with 300 ppm NO**

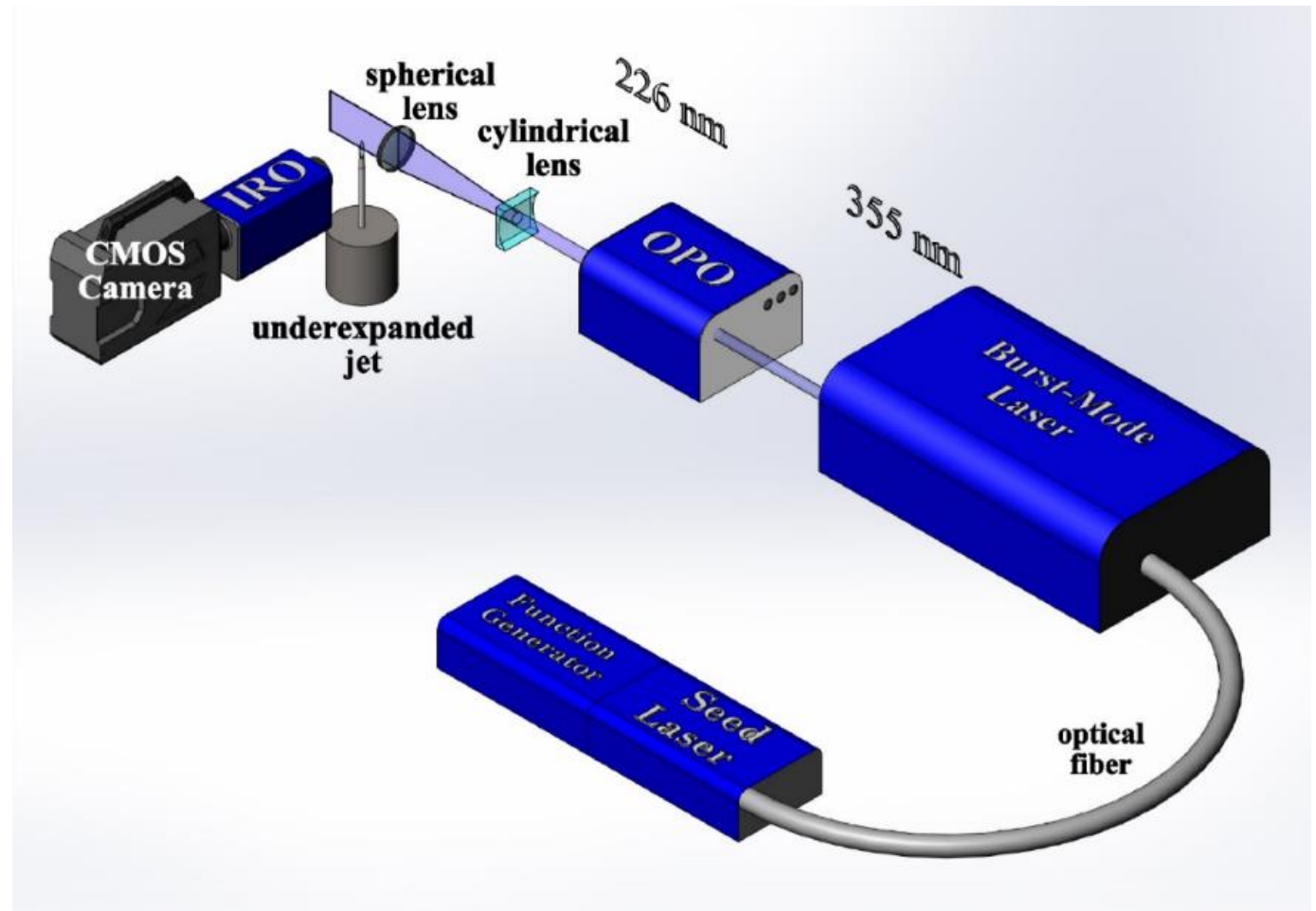

Frequency Scans at 100 kHz Laser Repetition Rate

- 226 nm laser wavelength scanned over two LIF transitions

$Q_1(11.5) + R_{21}(11.5)$ $R_1(5.5) + Q_{21}(5.5)$

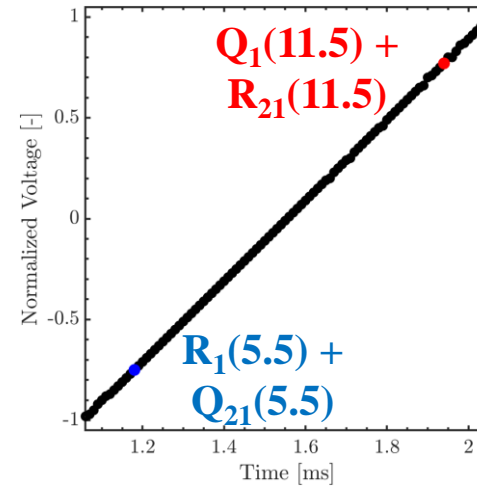
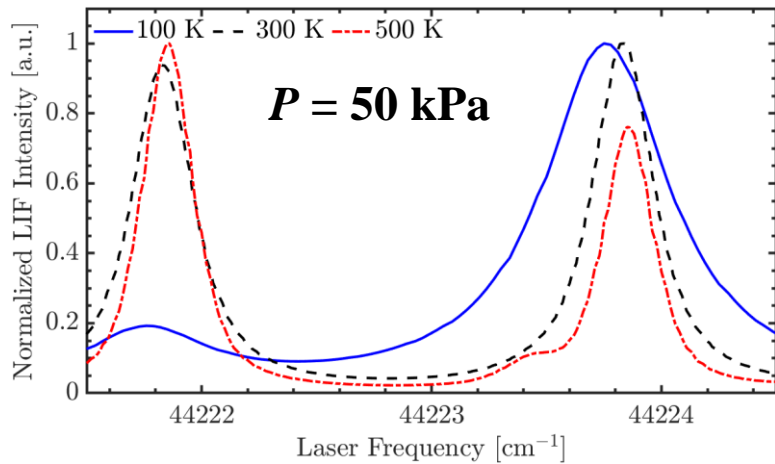
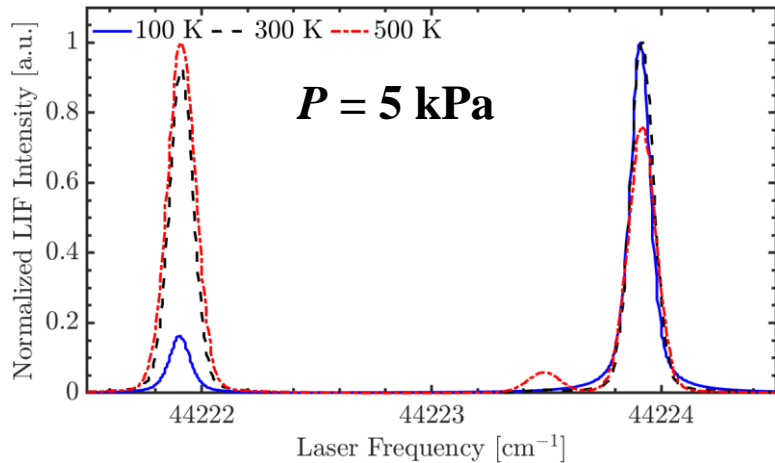

$P_0/P_a = 10$

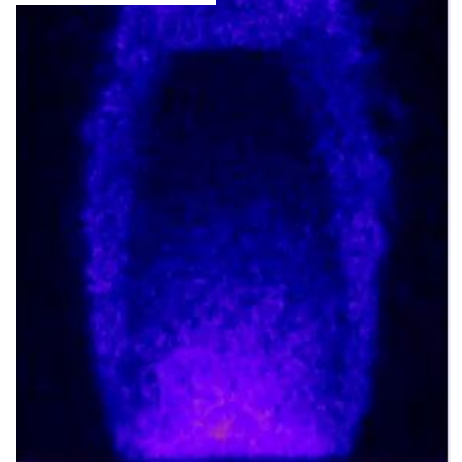

$\tau - 10 \mu\text{s}$ $\tau - 10 \mu\text{s}$ $\tau - 10 \mu\text{s}$ τ $\tau + 10 \mu\text{s}$ $\tau + 20 \mu\text{s}$ $\tau + 30 \mu\text{s}$

$R_1(5.5) + Q_{21}(5.5)$

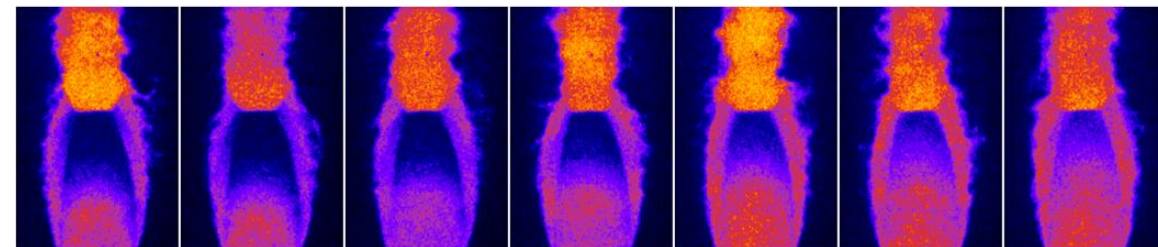

(a)

$Q_1(11.5) + R_{21}(11.5)$

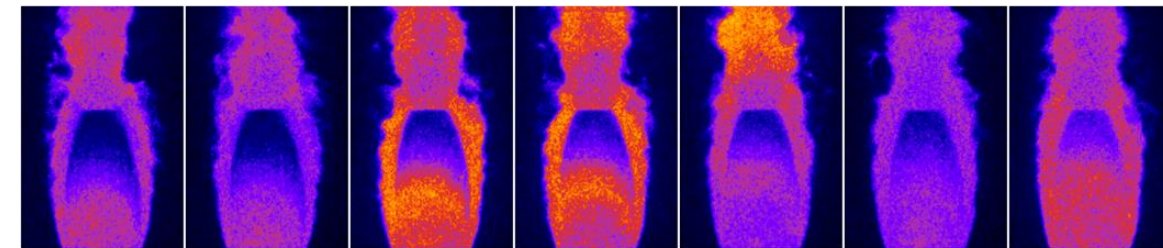

(b)

2.6 mm

$P_0/P_a = 10$

Towards Quantitative T , P , and V

- **2D Temperature**
 - Rotational thermometry
- **2D Pressure: Collisional Shift**
 - Collisional broadening another option
- **2D-1C Velocity: Doppler Shift**
- **Results reported in Rodrigues *et al.* (2023 AIAA SciTech) summarizing progress**
 - Shown qualitatively due to issues with wavelength scan uniformity
- **Current efforts including using high-speed wavemeter for wavelength monitoring**
 - Presentation by Dr. Amanda Braun for Filtered Rayleigh Scattering application

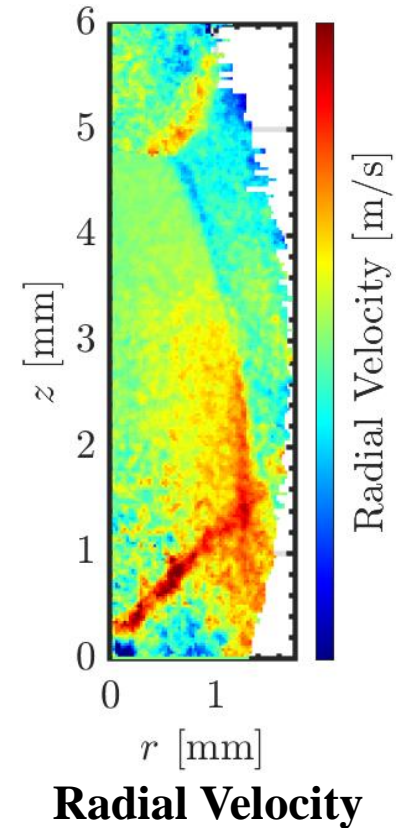
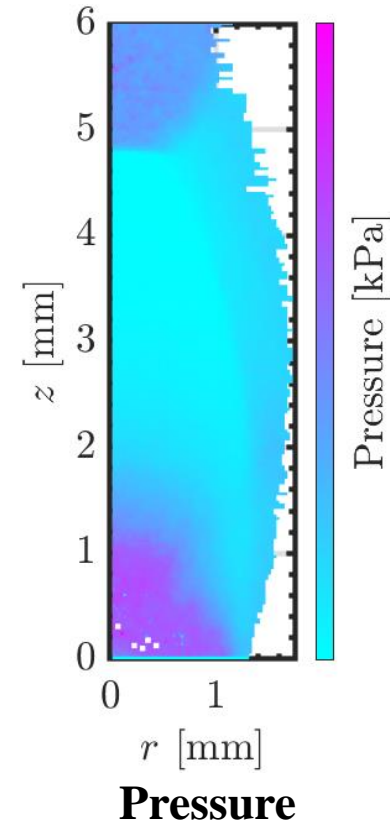
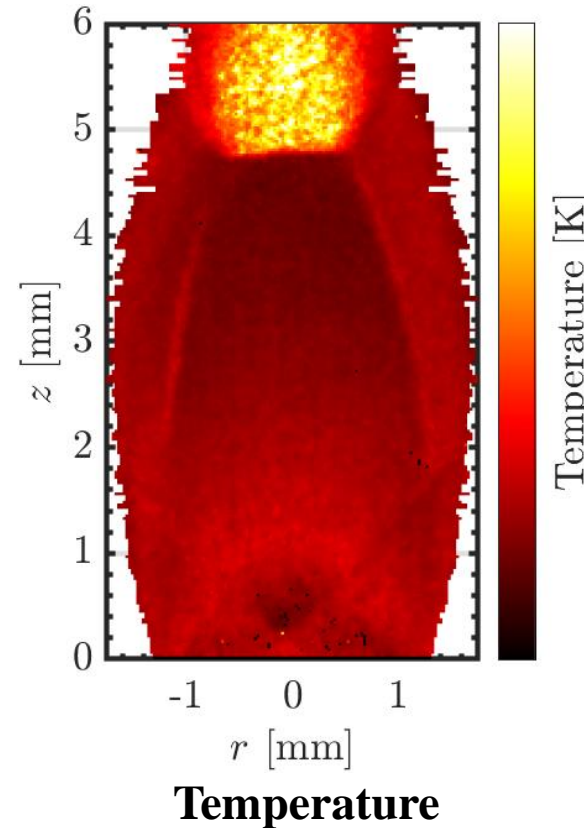

Molecular Tagging Velocimetry (MTV) at 100 kHz

- 6 laser lines used to tag and track underexpanded jet at multiple locations at 100 kHz repetition-rate

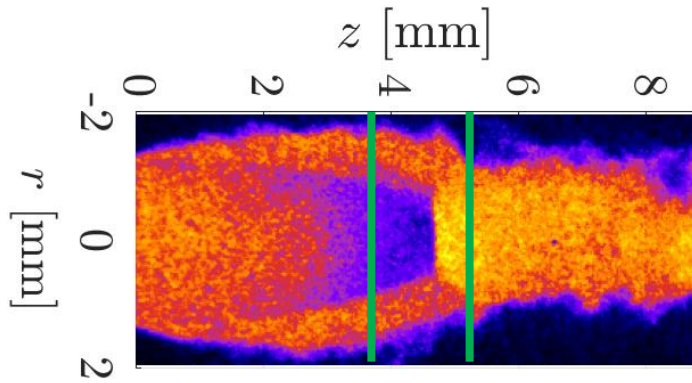

- More details in 2024 *Applied Optics* Paper (Rodrigues, Jiang, Hsu, Roy, Danehy)
 - Similar work reported by Sandia group
- New NO MTV technique to be presented by Dr. Paul Hsu based on 2024 *Optics Letters* paper (Jiang *et al.*, 2024)
 - Similar technique also recently reported by Texas A&M group

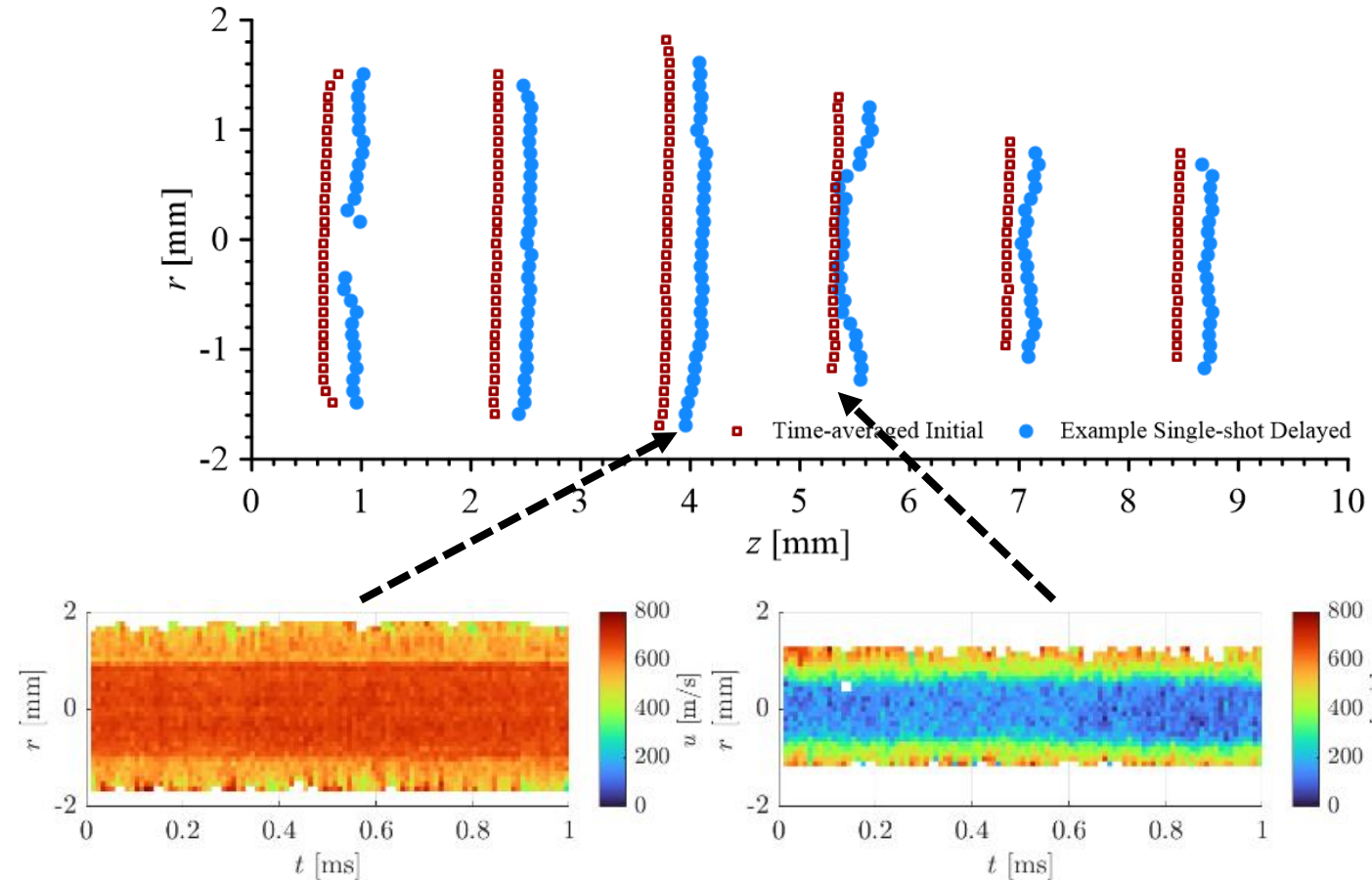

Summary and Conclusions

- **Planar laser-induced fluorescence used at NASA Langley to support Space Technology and Exploration projects**
 - Provides understanding of flow physics, validation of CFD codes, help engineer better flight vehicles
- **Two recent PLIF applications in large-scale environments summarized:**
 - Hypersonic wakeflows
 - Plume impingement
- **High-speed PLIF development**

Outlook: interest in space exploration higher than recent decades

- **Including commercial partners**

