

Concept Design of a 5 MW Axial Flux Partially Superconducting Electric Machine

Thomas Tallerico, **Aaron D. Anderson**, and Justin Scheidler
NASA Glenn Research Center, Cleveland, OH, 44135, United States

AIAA Aviation Forum/Electric Aircraft Technologies Symposium
29 July-2 August 2024

This material is a work of the U.S. Government and is not subject to copyright protection in the United States.

This work was funded by NASA's Advanced Air Transport
Technology (AATT) Project

Partially superconducting machine background

- Electric propulsion of transport class aircraft requires motors and generators with
 - High efficiency
 - High specific power
 - Power >1 MW
- Superconductors are an enabling technology by generating strong magnetic fields with zero conduction loss
- NASA Glenn's HEMM (High Efficiency Megawatt Motor) is a partially superconducting machine as documented in many previous publications
 - 1.42 MW continuous output
 - 16 kW/kg electromagnetic specific power
 - >98% efficiency
 - Rotating cryocooler integrated into the shaft

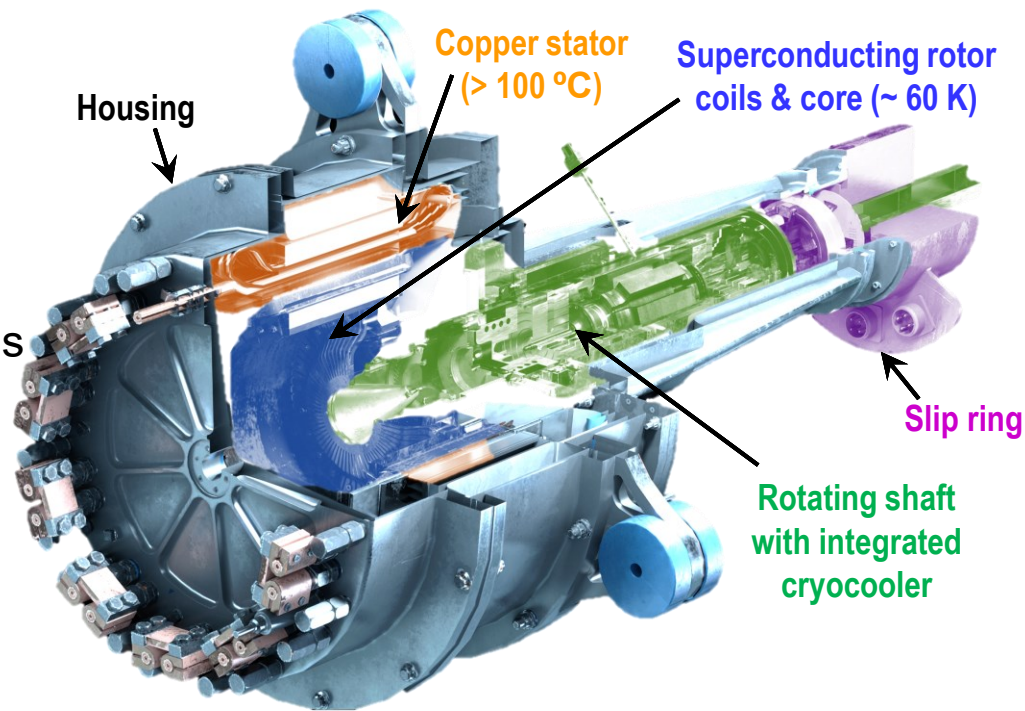

NASA's SUSAN Concept Vehicle and Requirements

- NASA's SUSAN concept airplane requires 5 MW generators
- This presentation describes a study of different machine topologies for SUSAN generators

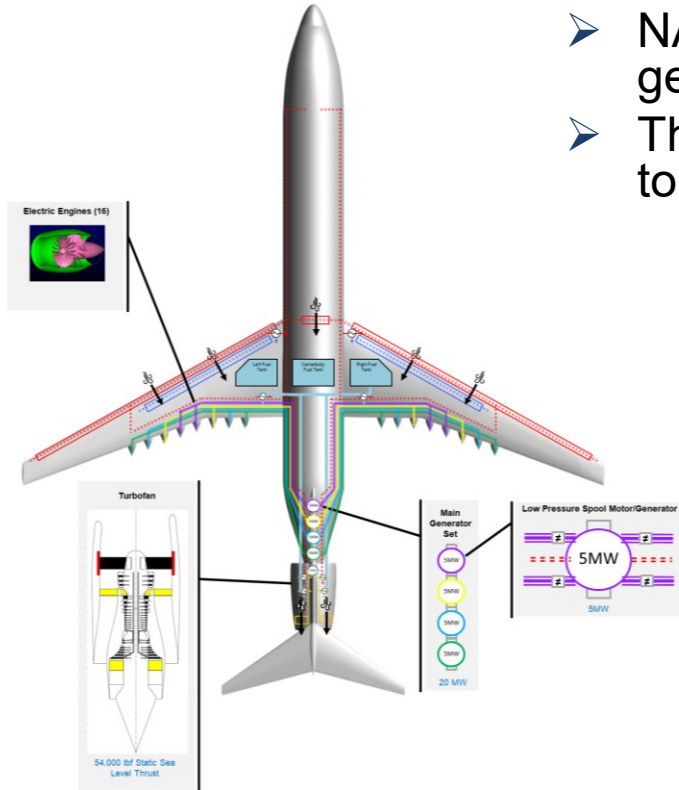

Key Requirements and Assumptions

Efficiency	99 %	Stator and Rotor Iron Material	$\text{Fe}_{49.15}\text{Co}_{48.75}\text{V}_2$
Specific Power	25 kW/kg	Stator Conductor Material	Copper litz wire
Nominal Rotational Speed	5951 rpm	Stator Strand Insulation	MW-16 polyimide
Maximum Radius	0.5 m	Stator Potting Epoxy Thermal Conductivity	1.9 W/(m*K)
Rotor Type	Wound field	Stator Cooling	Direct liquid
Rotor Cooling	In-shaft cryocooler	Coolant Inlet Temperature	60 °C
Rotor Conductor	2G high temperature superconductor (REBCO)	Maximum Allowable Stator Temperature	180 °C
Rotor Coil Fill	90%	Coolant	PAO

J. W. Chapman, J. L. Kratz, T. P. Dever, A. Mirhashemi, E. J. Stalcup, W. R. Sixel, A. A. Woodworth, R. H. Jansen and N. Heersema, "Update on SUSAN Concept Vehicle Power and Propulsion System," in AIAA SCITECH 2023 Forum, National Harbor MD, 2023.

Outline

- Topologies considered
- Optimization approach and results
- Model validation of selected design
- Conclusion

Outline

- Topologies considered
- Optimization approach and results
- Model validation of selected design
- Conclusion

Machine topologies: Axial-flux

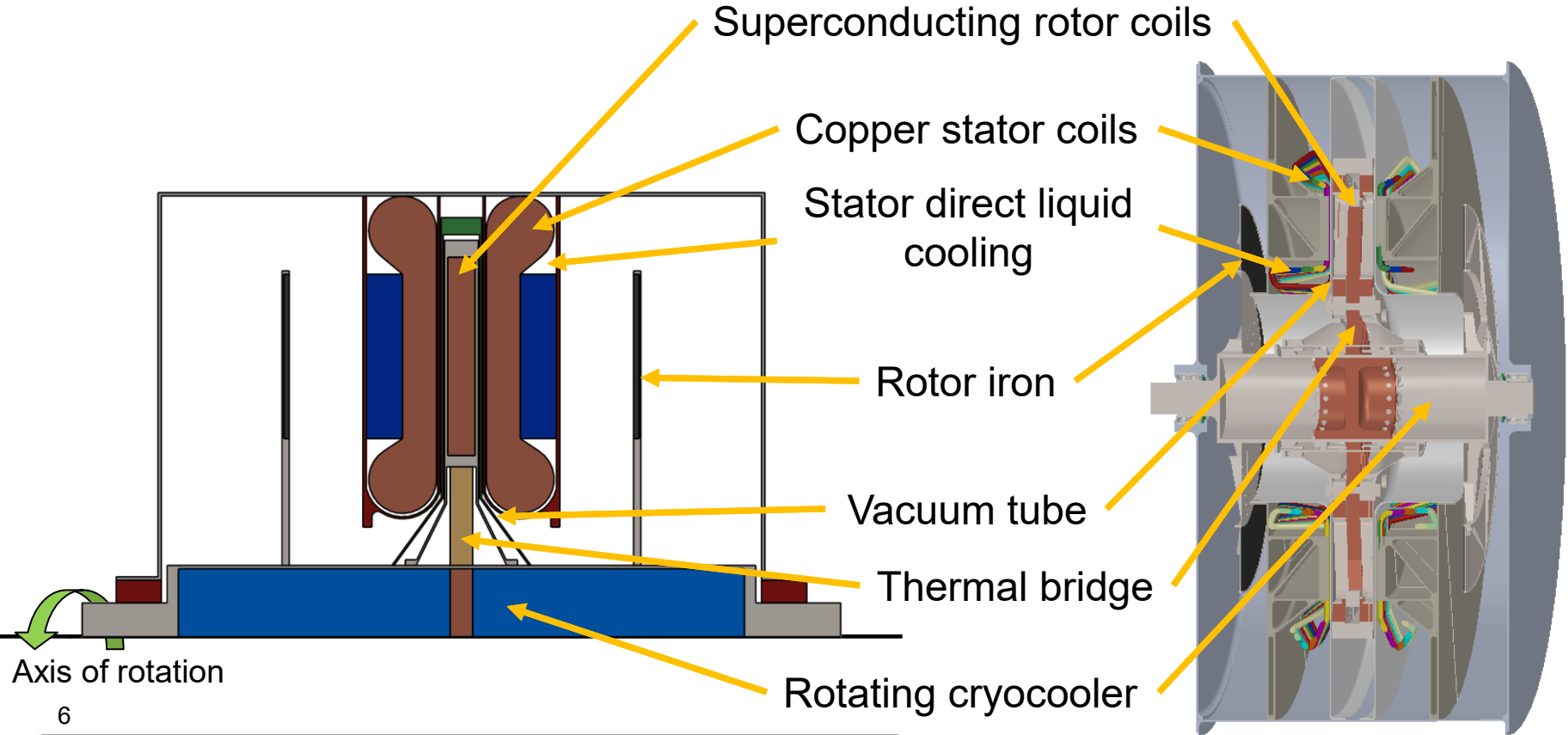

Machine topologies: Axial-flux variants

- Rotor thermal bridge variants:
 - Extends only to inner diameter of rotor coils
 - Minimizes magnetic airgap
 - Extend to full outer diameter of rotor coils
 - Improves thermal contact
 - Mechanically more practical
- Vacuum tube variants:
 - Stationary
 - Mechanically simpler
 - Requires rotating vacuum seals
 - Rotating
 - Functions as an eddy current shield, reducing cryocooler heat load
 - Has windage losses

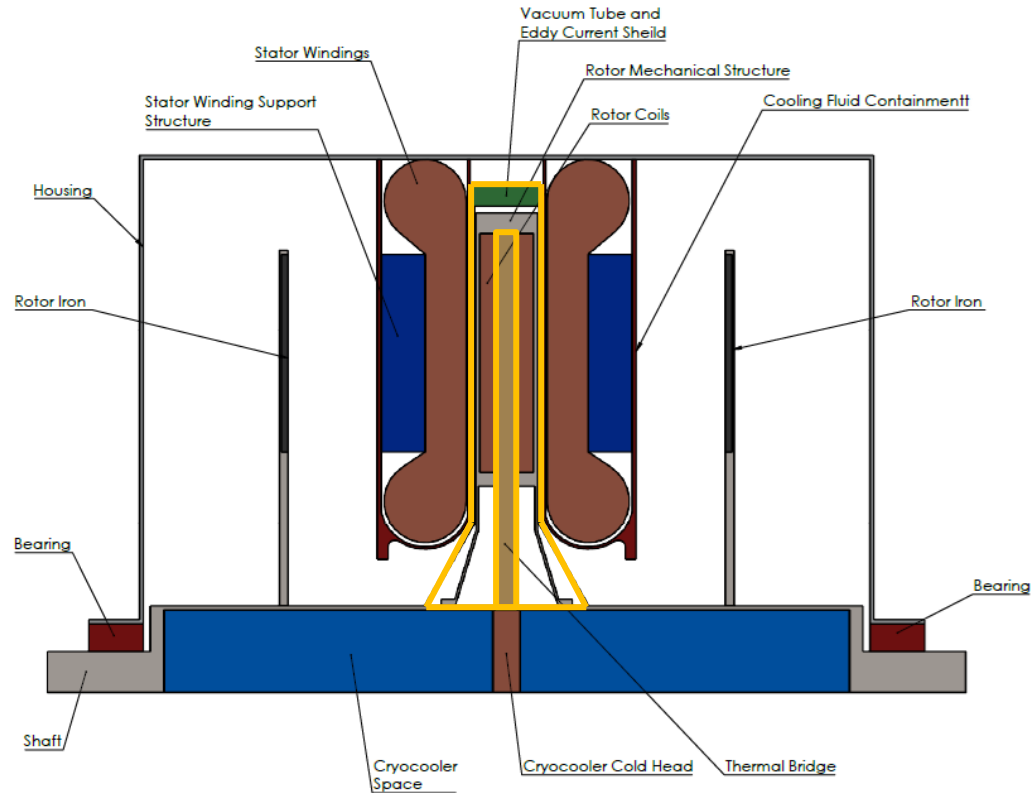

Machine topologies: Axial-flux variants

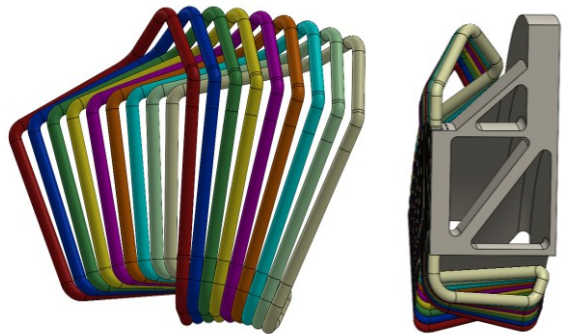

Distributed

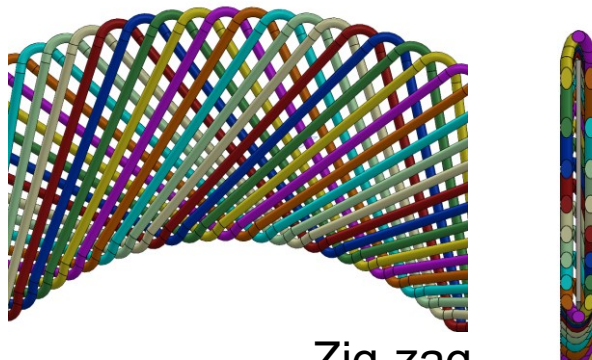

Zig-zag

- Stator winding variants:
 - Distributed
 - Smaller airgap
 - Well-aligned with rotor field shape
 - Zig-zag
 - Shorter end-turns

Machine topologies: Axial-flux variants

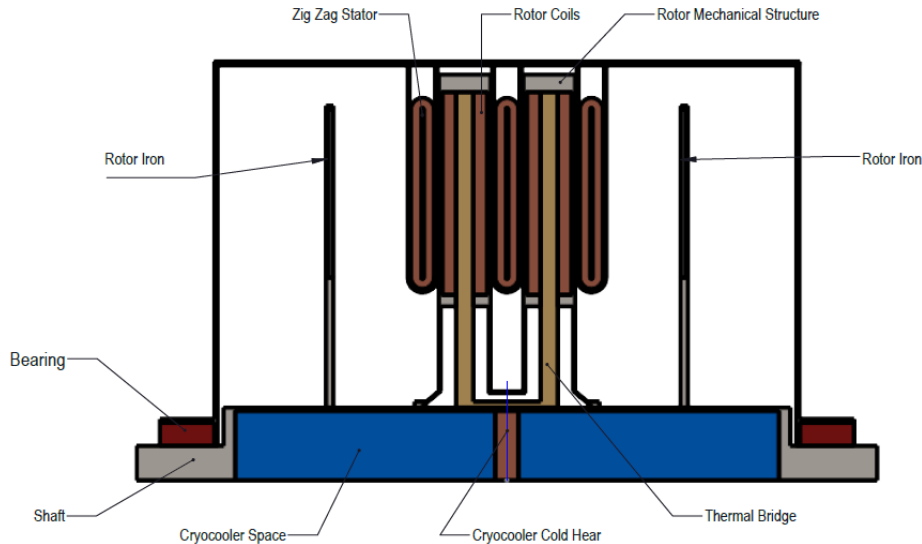

- Multi-rotor variants:
 - One rotor, two stators
 - Mechanically simpler
 - Two rotors, three stators
 - More area for force generation
 - Distributed coils are impractical for the middle stator
 - Rotating vacuum tube significantly more difficult

Machine topologies: Radial-flux

- Radial flux machine based on HEMM and documented in a paper presented at EATS 2023
- Stator back-iron variants:
 - Iron core
 - Same as HEMM
 - Air-core with distant back iron
 - Lower iron mass and loss
 - Longer flux return path
- Vacuum tube variants:
 - Stationary
 - Rotating

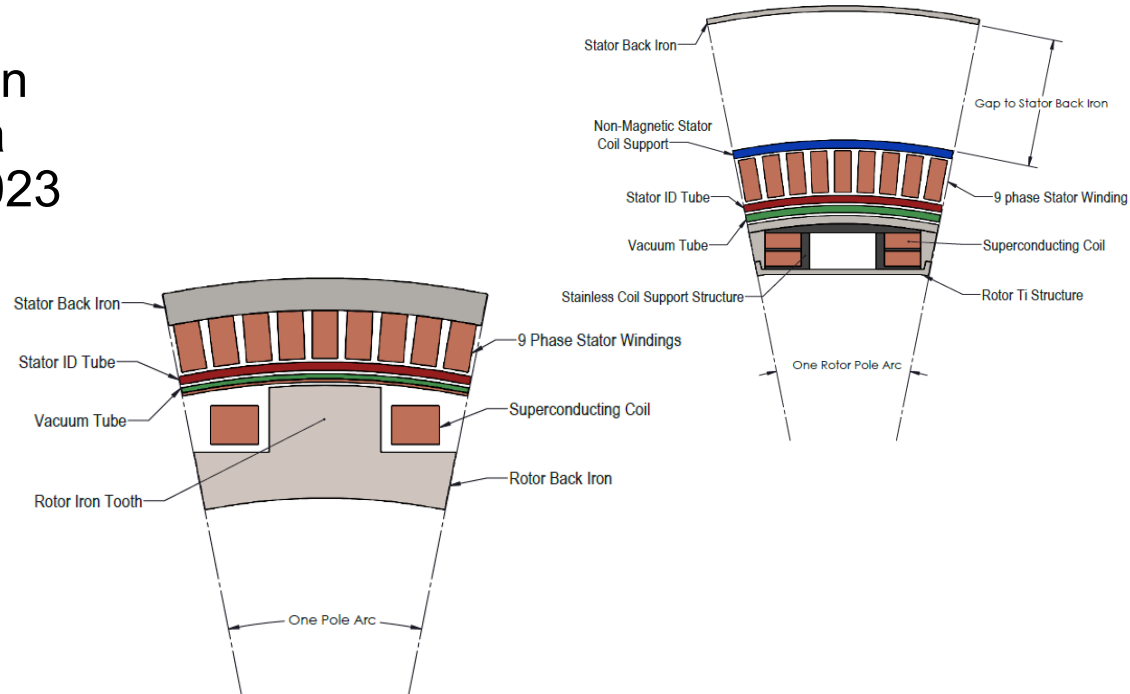

T. F. Tallerico, A. D. Anderson, J. J. Scheidler, R. Jansen and W. Sixel, "Concept Design of a 5 MW Partially Superconducting Generator," in AIAA Aviation Forum, San Diego CA, 2023.

Outline

- Topologies considered
- Optimization approach and results
- Model validation of selected design
- Conclusion

Optimization approach

Genetic optimization algorithm

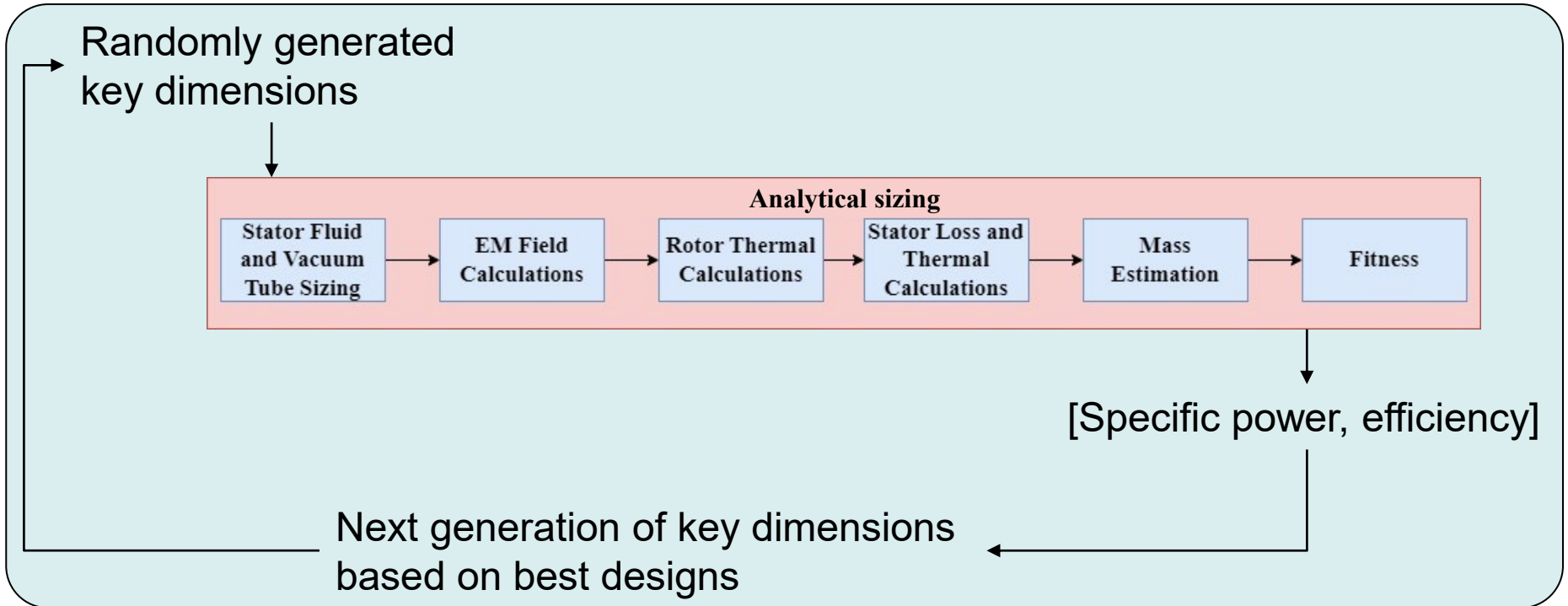

Optimization results

- Axial-flux machines fell slightly short of the design target, but were close enough to justify further model refinement
- Radial-flux, air-core designs could just meet the performance target

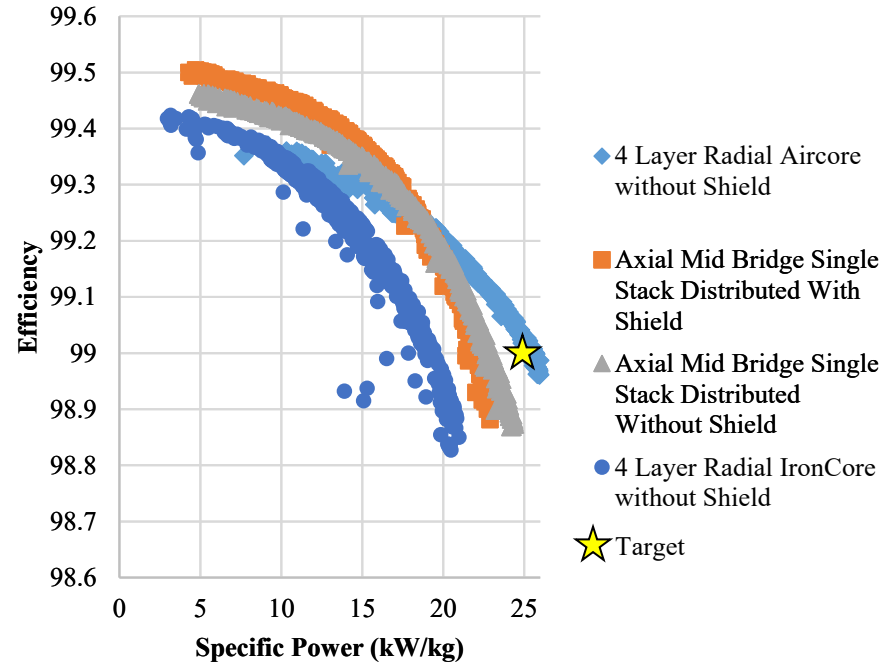

Outline

- Topologies considered
- Optimization approach and results
- **Model validation of selected design**
- Conclusion

Conceptual Design from Optimizer

Design parameter	Selection
Flux direction	Axial
Vacuum tube	Stationary
Rotors	Single
Thermal bridge	Full diameter
Stator winding type	Distributed
Efficiency	99%
Specific power	21 kW/kg

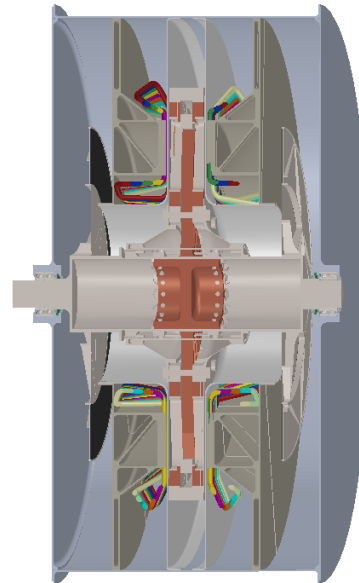

Full cross-section

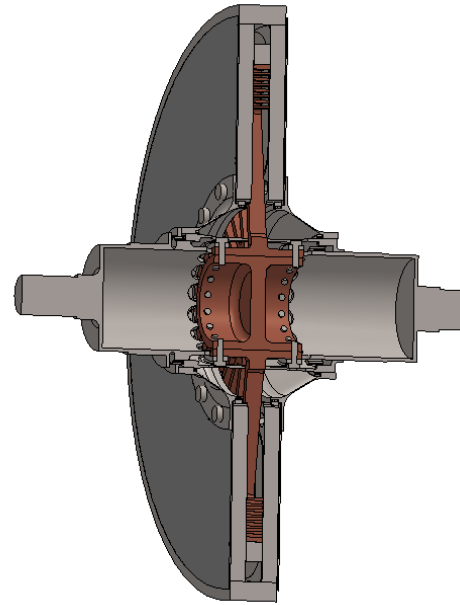

Rotor

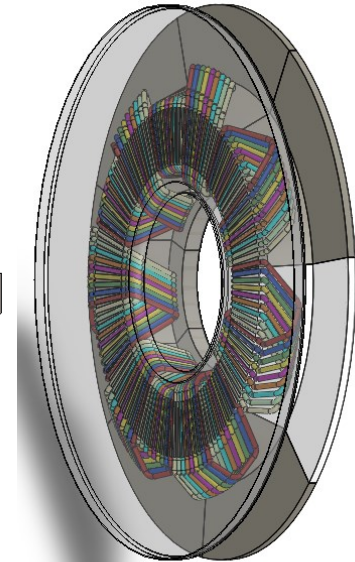

Stator

Detailed Electromagnetic Model

- 3D electromagnetic FEA results
 - Rotor end windings added about 7% extra torque
 - Flux leakage required an increased housing diameter, 12 kg added

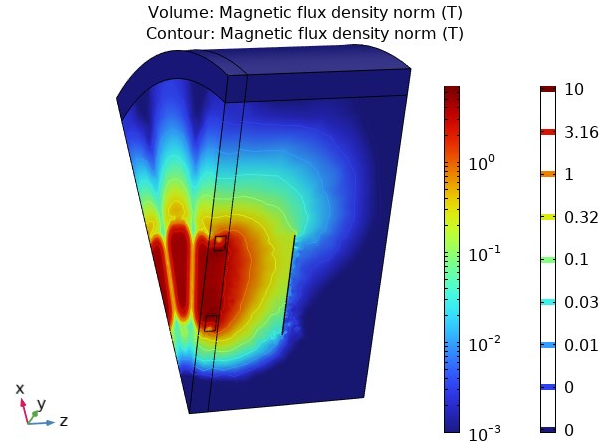
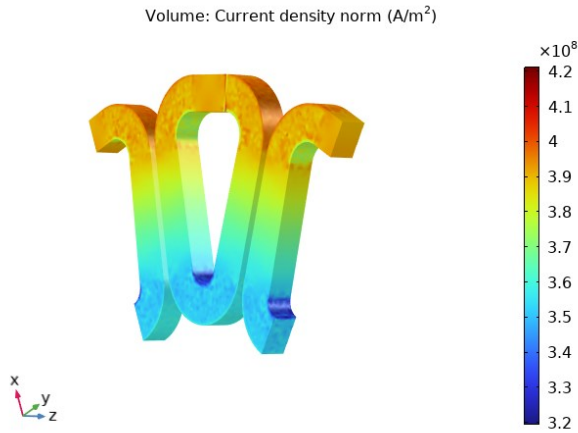

Detailed Stator Thermal Model

- 2D stator thermal model
 - Peak temperature 58 °C cooler than analytical model
 - Motor can operate at 7 MW before exceeding thermal limits

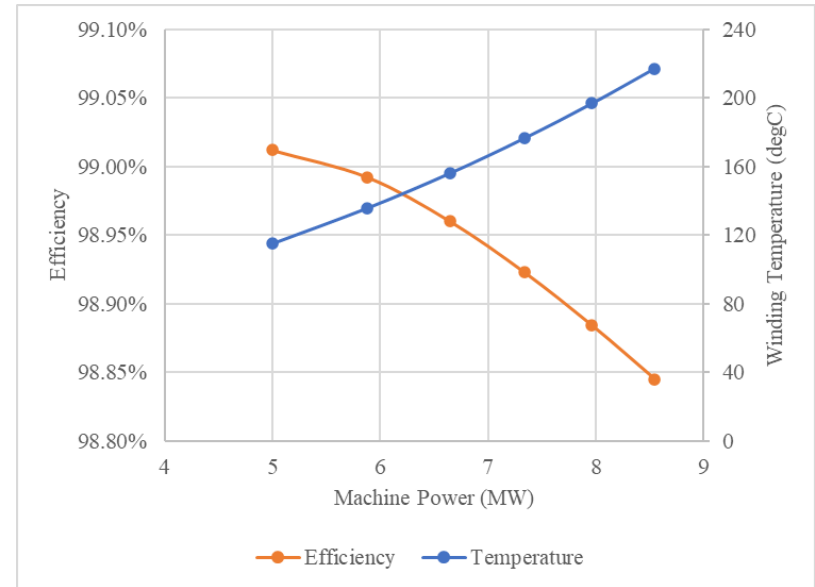
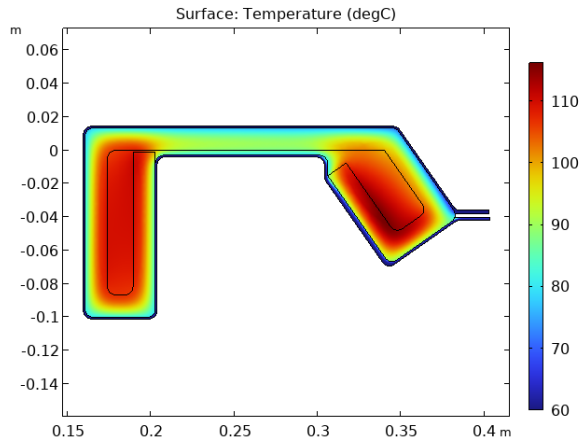

Detailed Rotor Thermal Model

- 3D rotor thermal model
 - Slightly lower rotor temperatures than analytical
 - Results are sensitive to thermal contact assumptions, but confirm the analytical model is reasonable

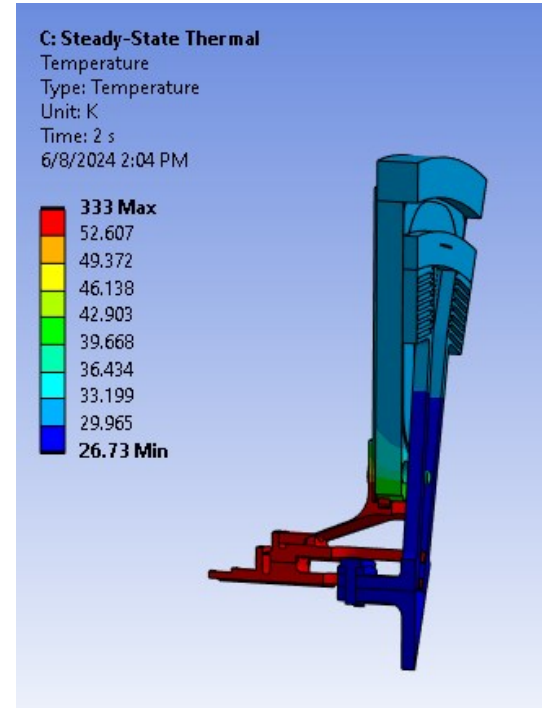

Detailed Rotor Mechanical Model

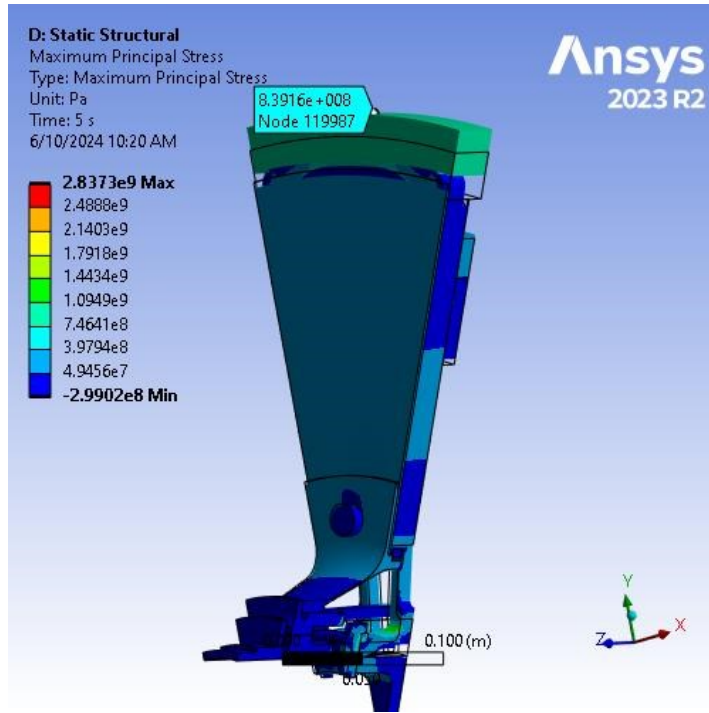

- 12 kg containment hoop required to react centripetal loading from coils

Outline

- Topologies considered
- Optimization approach and results
- Model validation of selected design
- **Conclusion**

Conclusions

- We developed a design tool for axial-flux, partially superconducting machines
 - It designed a machine predicted to operate at 99% efficiency and 21 kW/kg
 - After more detailed analysis, the axial flux machine showed 99% efficiency at 19 kW/kg with a lot of thermal margin
- Future improvements to the design tool may allow for a design that achieves 25 kW/kg at 99% efficiency
 - Account for 3D leakage flux
 - Account for centripetal loading
 - Improve thermal model to not be too conservative
- The radial-flux machine design tool found design that can achieve 25 kW/kg at 99% efficiency



AMERICAN INSTITUTE OF
AERONAUTICS AND ASTRONAUTICS

Backup

Design details from optimizer

Top Level		Currents	A
Rotor Pole Pairs	7	SC Critical Current	223
Stator Slots	126	Rotor DC Current	145
Power	5 MW	Current Per Stator Slot (rms)	613
Rotational speed	5,951 rpm		
Electrical Frequency	694 Hz		
SC Coil Layers	8	Cryogenic Heat Loads	W
		Rotor Radiation	10.4
		Rotor Eddy Loss	15
Major Dimensions	m	Mechanical Heat Leak	25
Active Magnetic Outer Radius	0.302	Rotor Lead Loss	15
Active Magnetic Inner Radius	0.2027	Total Rotor Heat	65.4
Coil Width	0.0275	Cryocooler Lift	69.5
SC Tape Width	0.005		
Winding Thickness	0.0134		
Thermal Bridge Thickness	0.022		
Iron Offset	0.15	Temperatures	°C
		Cold Head	26.7
		Superconductor	37.6
Mass	kg	Stator Hotspot	174
Rotor Coil	67.1		
Rotor Mechanical	17.9		
Rotor Thermal Bridge	27		
Iron Rotors	11.2	Losses	W
Cryocooler	35	Fluid Flow Loss	93
Housing	22.23	Windage Loss	0
Stator Fluid Containment	4.5	Seal Loss	2,000
Stator Winding Mass	29	Stator Resistive Loss	26,814
Stator Structure Mass	20	Cryocooler Power	20,002
Total	233.93	Eddy Current Loss	633
Specific Power	21 kW/kg	Efficiency	99.01%

Axial flux results

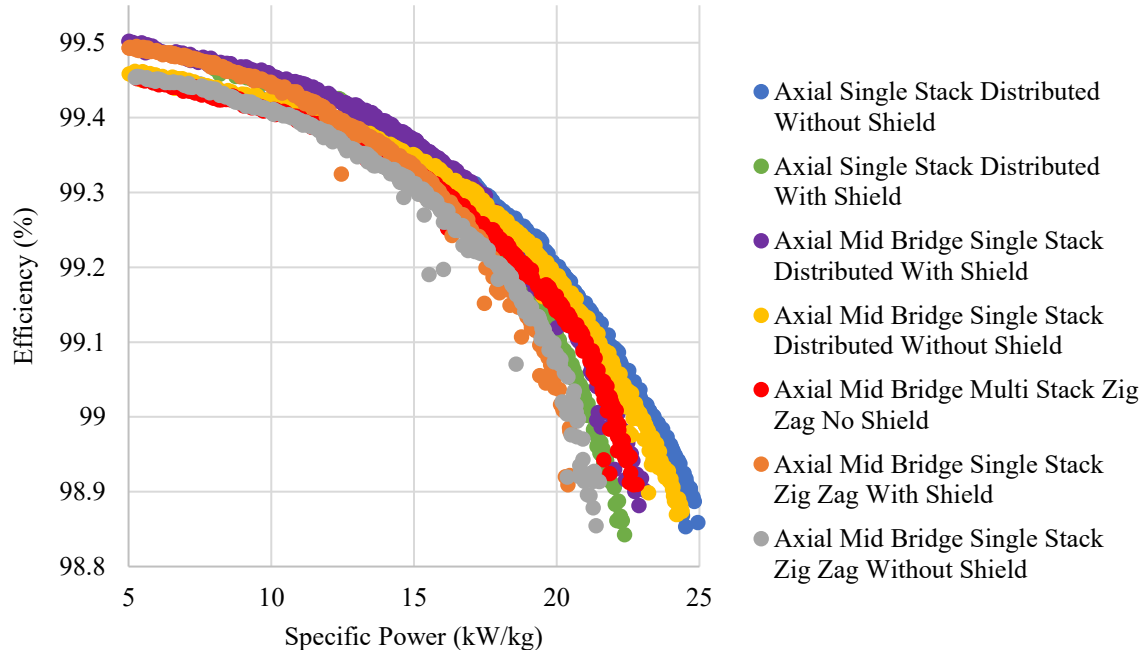

At specific powers above 16 kW/kg:

- No rotating shield was always better
 - Makes power electronics harder
- Distributed windings were better than zig-zag
 - Extra end windings mattered less than extra airgap and worse alignment between rotor and stator
- Mid-bridge improves performance only if there is a shield
 - Not viable because attaching rotor winding leads is impractical
- Multi-stack was better than single zig-zag, but not as good as distributed

Axial flux temperatures

- No mid bridge runs considerably warmer than with a mid bridge due to better thermal contact
- No shield runs warmer than with shield due to eddy current losses

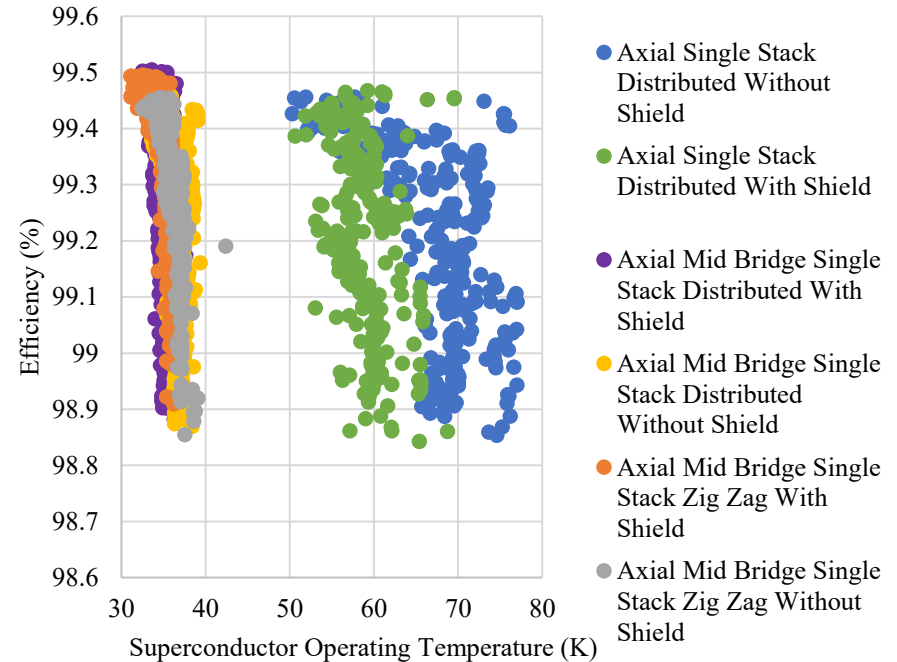

Radial flux air core results

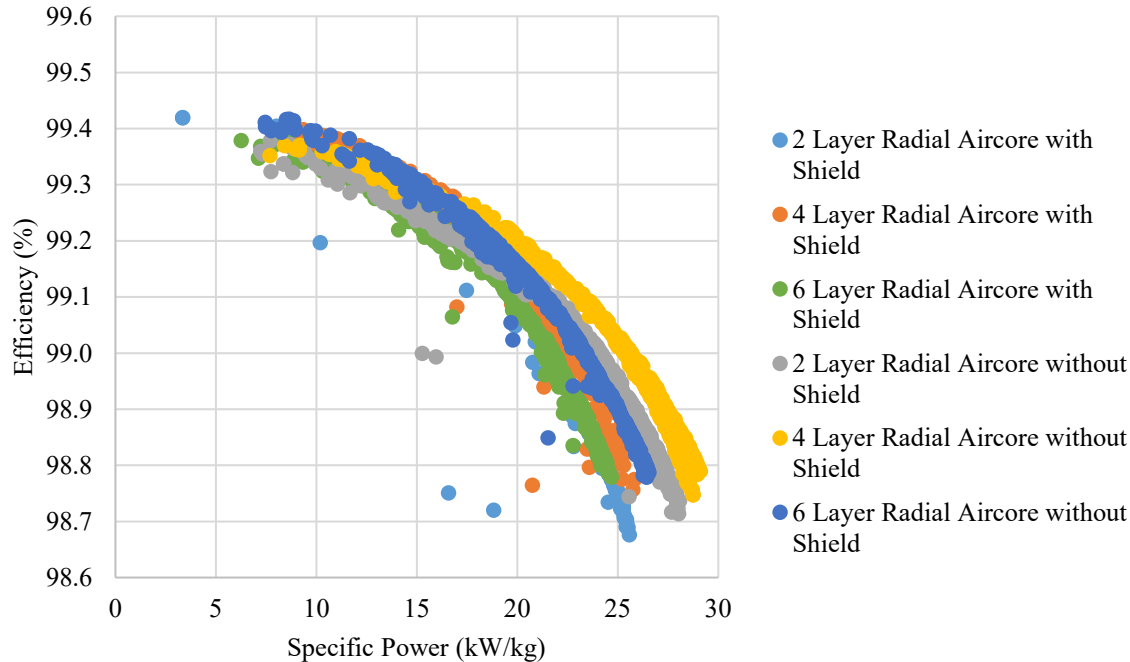

Above 16 kW/kg:

- No rotating shield was better
- 4 layers of superconducting coils was optimal

Radial flux air core temperatures

- More layers runs cooler
- With shield runs cooler

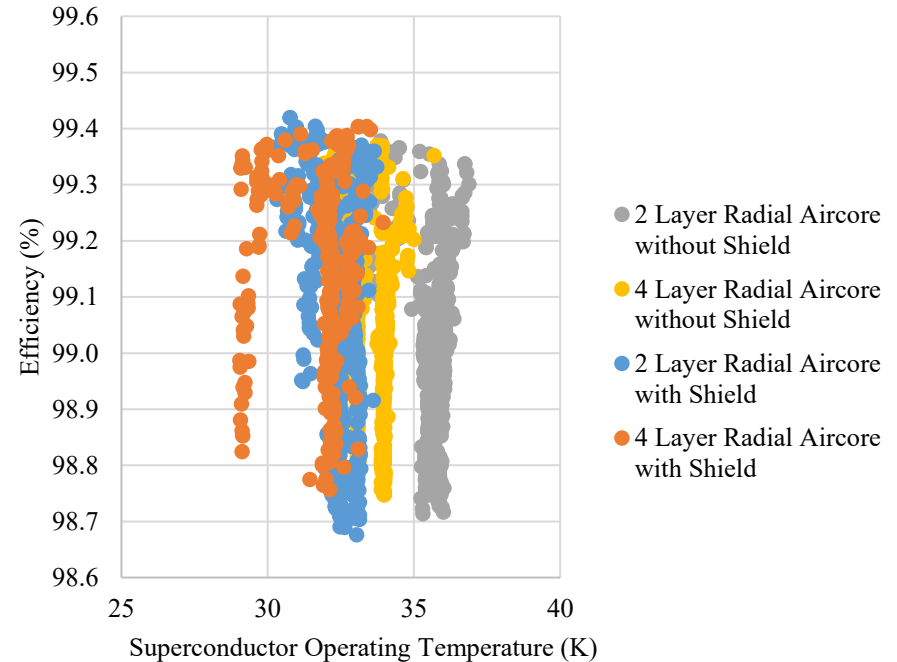

Radial Flux iron core results

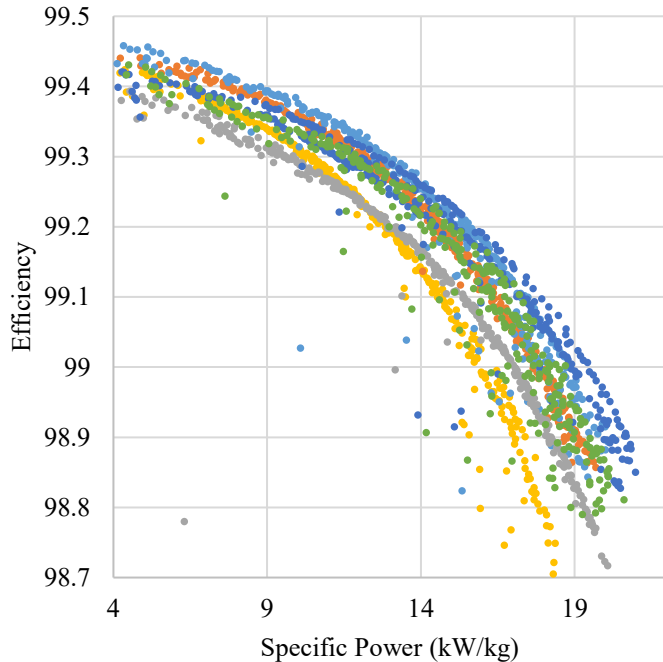

- Far too heavy, but might be competitive for applications with volume constraints
- Layers:
 - 6 is optimal with shield, 4 without shield
- No rotating shield is better