

AIAA ASCEND

1 August 2024



EXPLORESpace TECH  
TECHNOLOGY DRIVES EXPLORATION

# Fuel Cell Technologies for Energy Storage

Ian Jakupca  
Fuel Cell Technology Lead  
NASA Glenn Research Center



# Fuel Cell Power and Energy Storage Technologies

# Power and Energy Storage Options

## ➤ Battery and Fuel Cell Technologies are Complementary not Competitive

- No power or energy storage technology meets all requirements for all applications
- Each technology has a place within the overall exploration space
- Energy Storage Metric = Specific Energy (W·hr/kg)
  - ❖ Packaged Li-ion Battery Systems ~ 160 W·hr/kg
  - ❖ Regenerative Fuel Cell Systems < 100 to > 600 W·hr/kg based on location and energy requirements

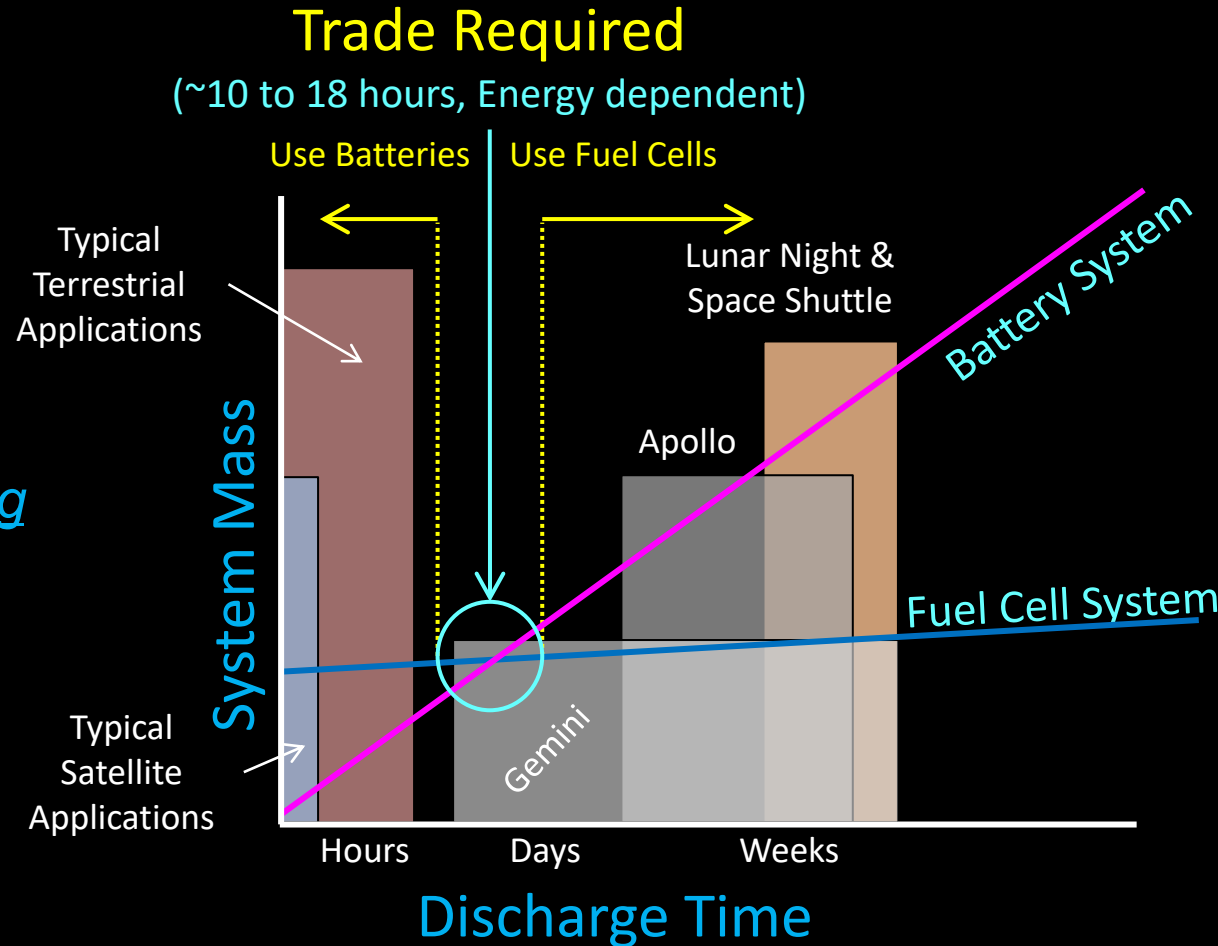

<b>Energy Options for Space Applications</b>	Battery = TRL 9
	Primary Fuel Cell = TRL 5 / 6
	Regenerative Fuel Cell = TRL 3

# Fuel Cell Power and Energy Systems

## Primary Fuel Cell

Discharge Power  
 $2\text{H}_2 + \text{O}_2 \rightarrow 2\text{H}_2\text{O} + 4\text{e}^- + \text{Heat}$

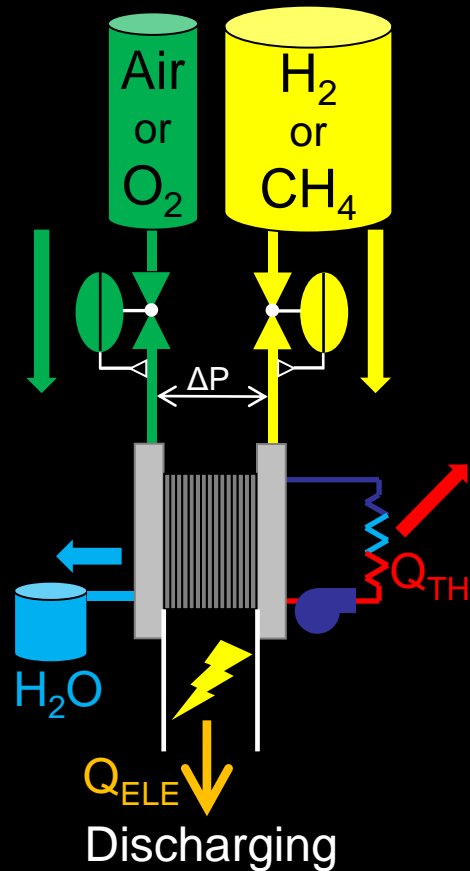

## Regenerative Fuel Cell

Energy Storage  
 $\eta_{\text{cycle}} \approx 50\%$

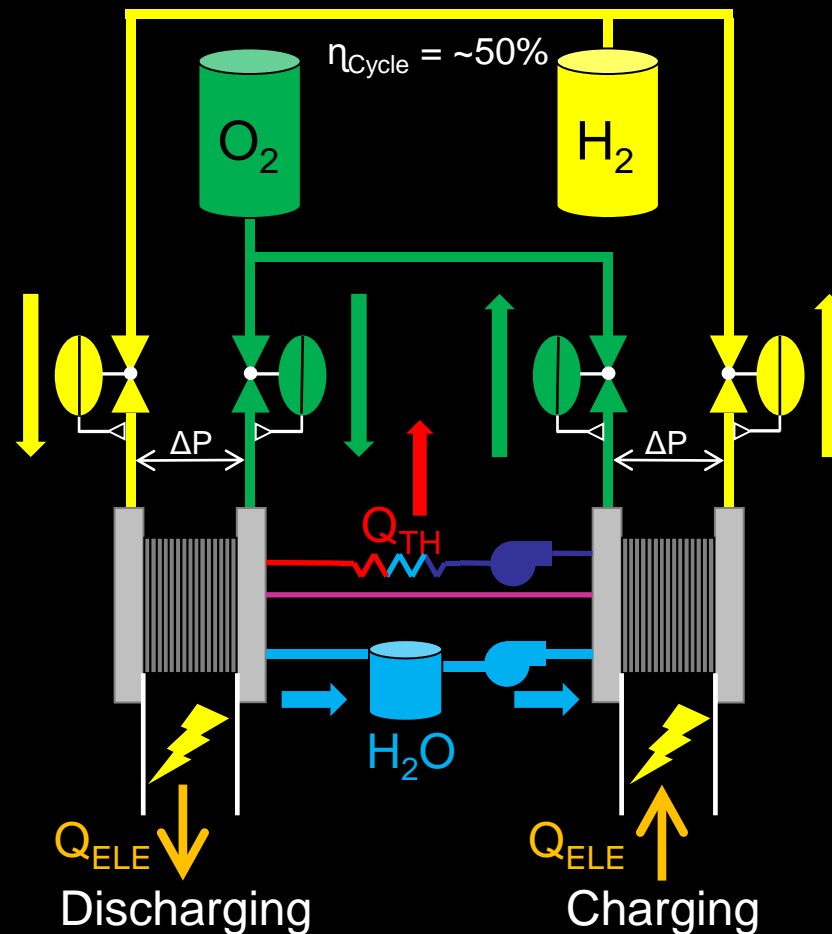

## Electrolysis

Product Generation  
 $2\text{H}_2\text{O} + 4\text{e}^- \rightarrow 2\text{H}_2 + \text{O}_2 + \text{Heat}$

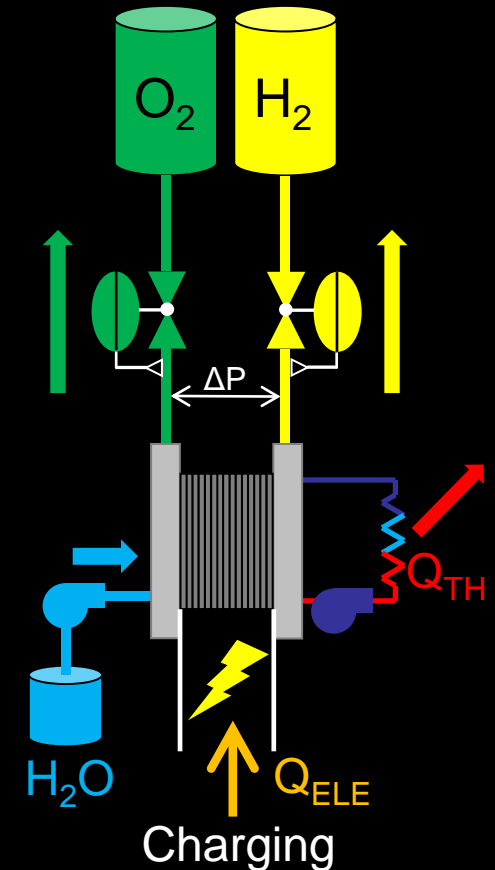

Regenerative Fuel Cell = Fuel Cell + Interconnecting Fluidic System + Electrolysis



# Fuel Cell System by Operational Environment

# Terrestrial Fuel Cell Systems

- Power both stationary and mobile platforms
- Scavenge O<sub>2</sub> from ambient air
- Atmosphere reservoir for product water
- Multiple viable fuel options
- Multiple viable electrolyte chemistries
- Cost the primary design constraint
- Ready access for maintenance



Long-distance vehicles (e.g. Class 8) trucks  
(Department of Energy Image)



Tanker trucks replenish liquid hydrogen (LH<sub>2</sub>) within large sphere at NASA's Kennedy Space Center in Florida, Launch Pad 39B.  
(NASA Image NHQ202208310013)



Maritime facilities including ports  
(Department of Energy Image)

# Aeronautic Fuel Cell Systems

- Power mobile platforms only
- Scavenge  $O_2$  from ambient air
- Atmosphere reservoir for product water
- Few viable electrolyte chemistries
- Limited viable fuel options
- Thermal management primary design constraint
- Specific power primary design requirement
- Ready access for maintenance



**Center for High-Efficiency Electrical Technologies  
for Aircraft (CHEETA)**

Design Study for Hydrogen Fuel Cell Powered Electric  
Aircraft using Cryogenic Hydrogen Storage

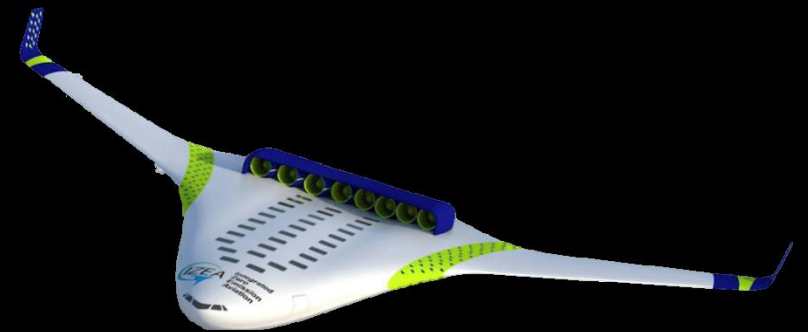

Concept  $H_2$ -fueled Aircraft for the Integrated Zero Emission  
Aviation (IZEA) ULI activity led by the University of Kentucky

# Cis-lunar Fuel Cell Systems

- Power vehicles when vehicle dynamics or energy requirements render PV/Battery options not viable
- Requires pure O<sub>2</sub> (no ambient air)
- $\mu$ g complicates product water separation
- Very few viable electrolyte chemistries
- Very limited viable fuel options
- Mass primary design constraint
- Very limited access for maintenance

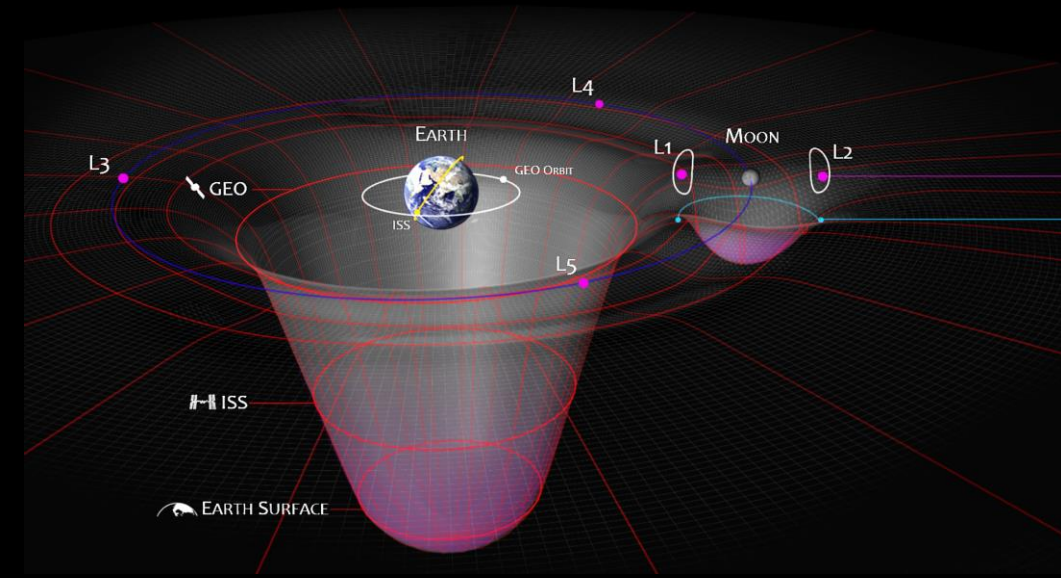

## Cislunar Space – A Deep Space Harbor for Exploration Missions

(NASA Advisory Council Human Exploration and Operations Committee Presentation, Jason Crusan, 12/7/2018)

# Lunar Surface Fuel Cell Systems

- Power stationary or mobile platforms
- Can enable lunar night survival
- Requires pure  $O_2$  (no ambient air)
- Low gravity not anticipated to complicate product water separation
- Very few viable electrolyte chemistries
- Very limited viable fuel options
- Operational life primary design requirement
- Maintenance primary design constraint
- Thermal Management and Dust mitigation require additional work



**A Notional Human Habitat at the lunar South Pole**  
(NASA image)



**Blue Origin Lunar Lander**  
Baselined Fuel Cell Power  
as primary power source

# Mars Surface Fuel Cell Systems

- Power stationary or mobile platforms
- Requires pure O<sub>2</sub> (Insufficient ambient air)
- Terrestrial product water separation techniques viable
- Very few viable electrolyte chemistries
- Very limited viable fuel options
- Operational life primary design requirement
- Maintenance primary design constraint
- Dust mitigation requires additional work



# Summary

- Select optimal technology for the application
- Every environment offers benefits and challenges
- Many, but not all fundamental aspects port between environments

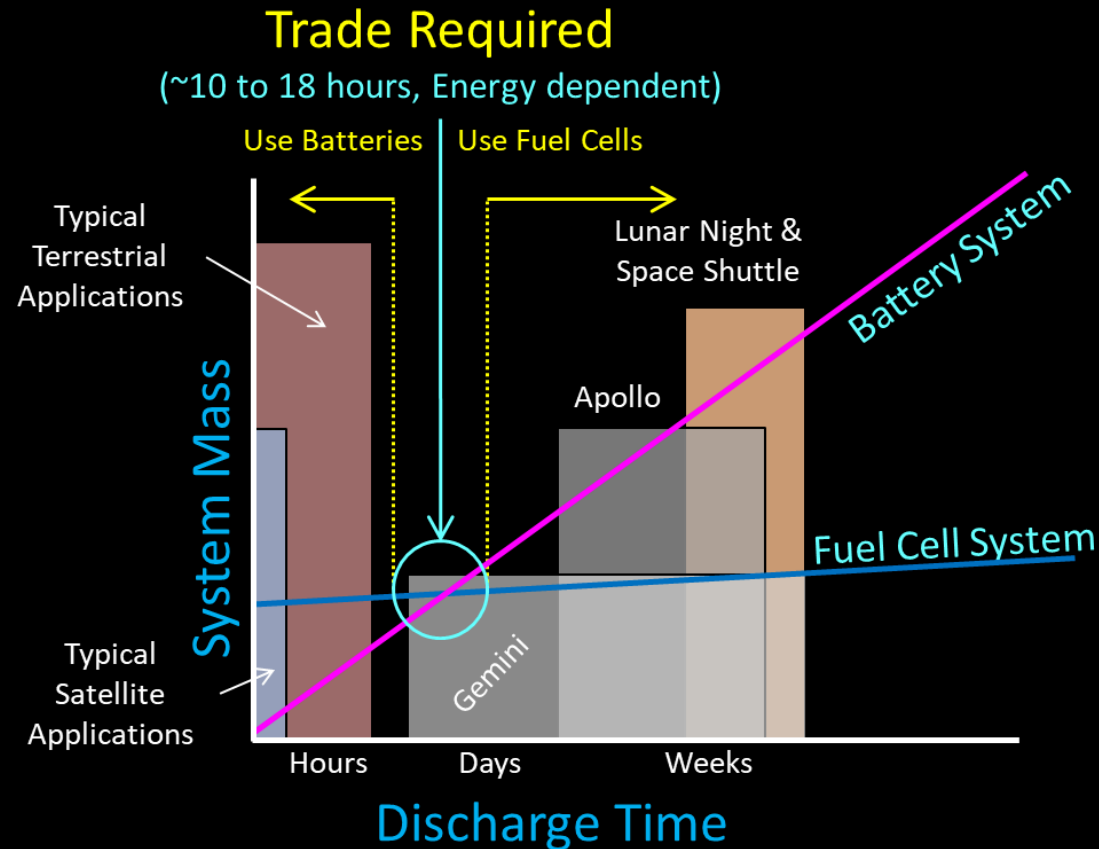



**Thank you for your attention.**