

Thermal Vacuum Testing of a Modified COTS Camera for use in Lunar Environments

Parker D. Weide
NASA MSFC ES22



Presented By
Parker Weide

Thermal & Fluids Analysis Workshop
TFAWS 2024
August 26-30, 2024
NASA Glenn Research Center
Cleveland, OH

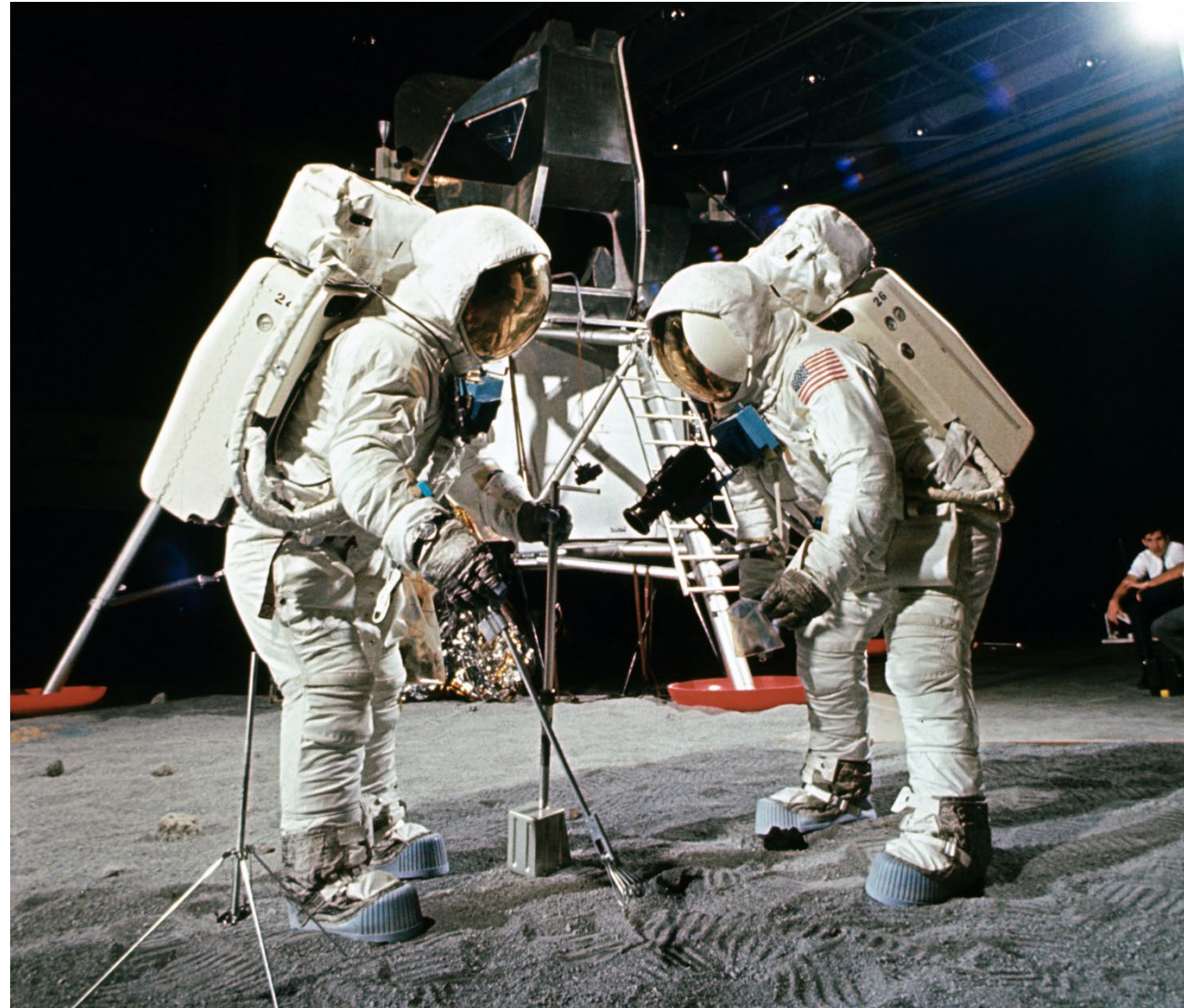

Why COTS?

- **Cost of hardware**
- **Availability**
- **Established user base**
- **Modified COTS sparked much attention during Gemini missions**



Credit: nasa.gov



Credit: nssdc.fsf.nasa.gov

- Analysis and test to ensure the HULC and its TPS will survive the lunar environments
 - Simulate use cases, thermal loads
 - Dust mitigation
 - Astronaut hands
- Characterization of the thermal response of the HULC to expected use cases
 - Time to failure
 - How usage affects survivability
 - How environment affects operation

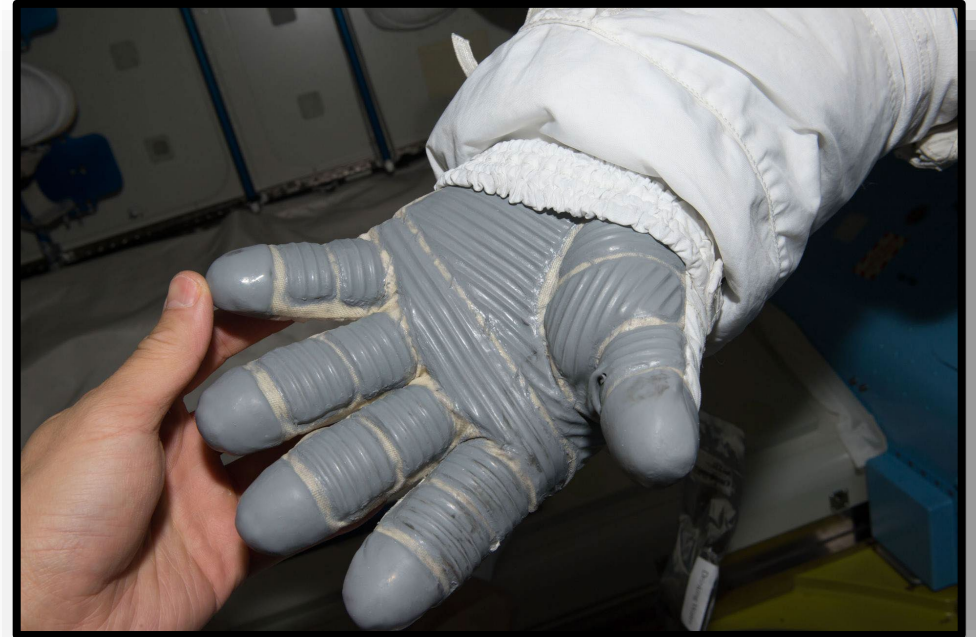

Credit: nasa.gov

- Temperature
 - Highly transient, especially during morning and evening
 - Variability increases near poles
 - Delta between surface and deep space
- Environment
 - Lack of natural convection
 - Regolith
 - Radiation
 - Astronauts

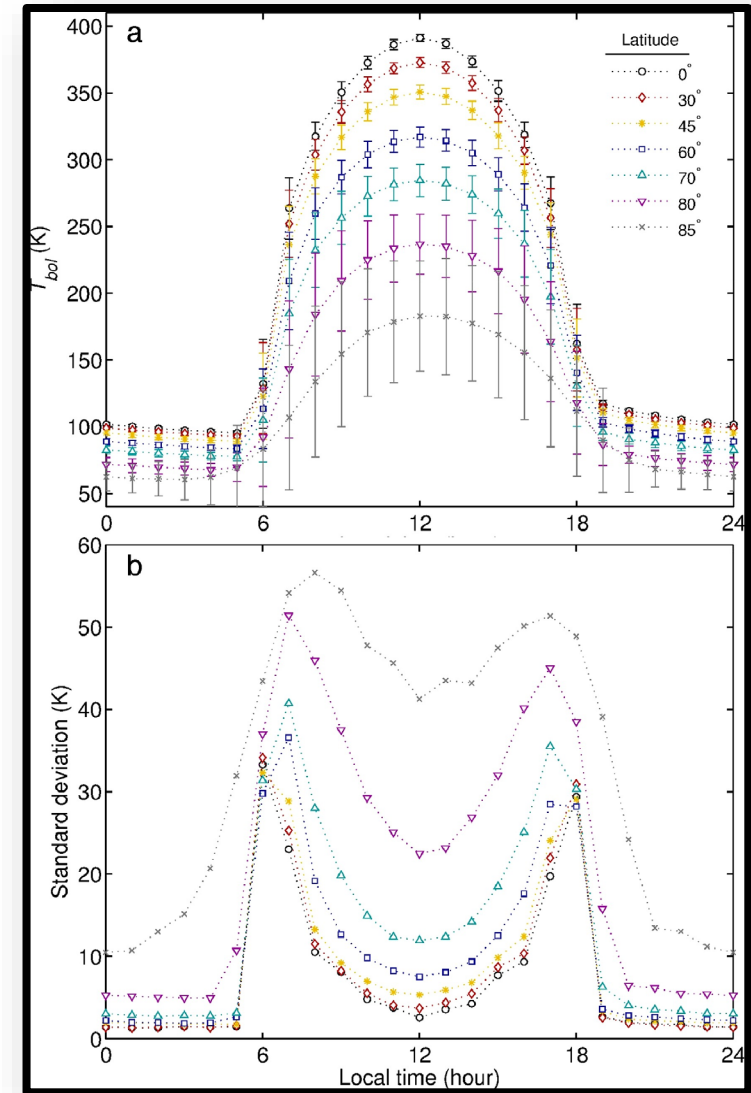

Williams et al. 2017

- Many benefits from substantial TVAC testing
 - Corollary data for model
 - Identify issues not displayed during benchtop testing or analysis
 - Qualification of hardware
 - Characterization of operations



Credit: esa.int

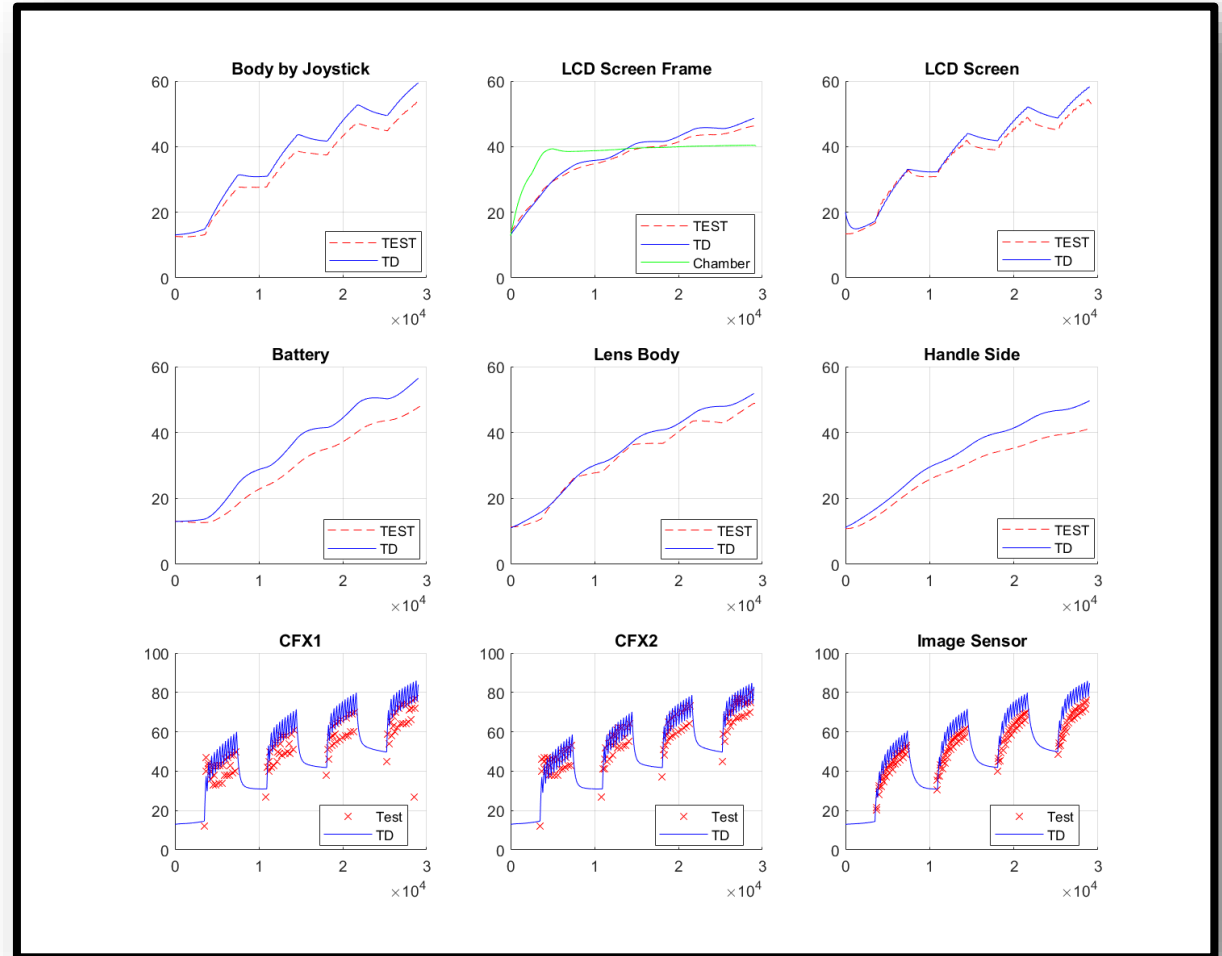

- **Camera Modifications (Hardware)**
 - Thermal blanket
 - 7 layer MLI with Orthofabric shells
 - Custom fit for camera
 - Designed with regolith protection in mind
 - Component selection
 - Lens(es)
 - Storage card



Credit: esa.int

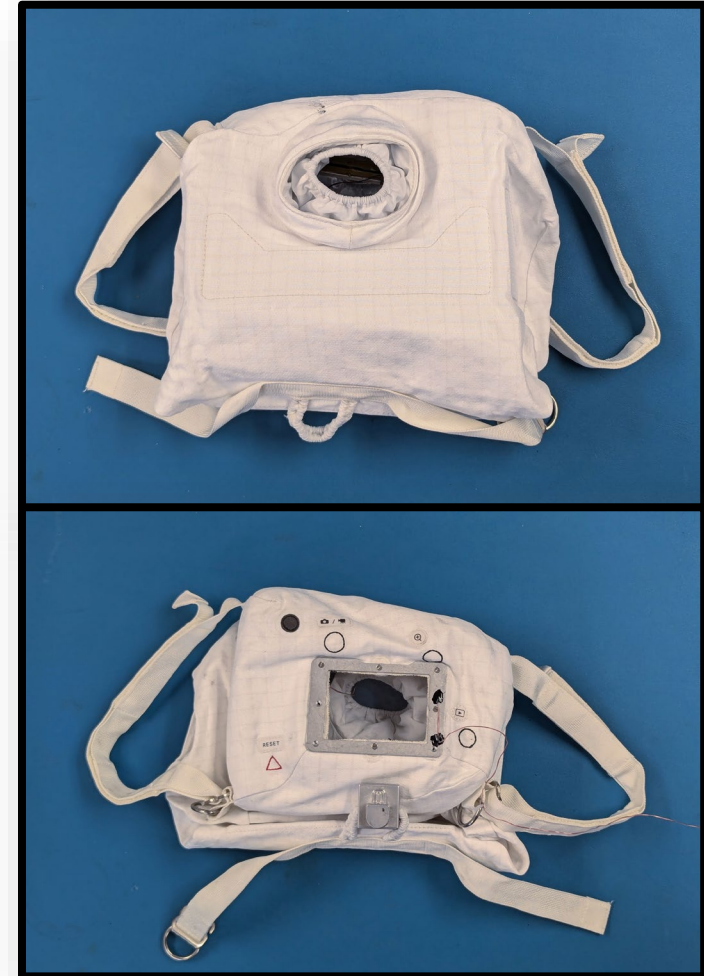

- **Camera Modifications (Hardware)**
 - Mechanical mounts
 - Handle mount
 - Aluminum, to attach to carrying handle
 - Lens mount
 - Reduce dust ingress



- **Thermal Vacuum Chamber Setup**

- VAC
 - HI-TTeMP Lab at MSFC
 - 1E-4 Torr
 - Ambient thermal control
- TVAC
 - ETF at MSFC
 - Temperature control by LN2 shroud
 - Thermally isolated from floor
 - Secondary camera to watch HULC LCD screen
- Thermocouples attached using Stycast at predetermined points
- Blanket present for EVA tests, absent for IVA tests
- Control provided through '10-pin'

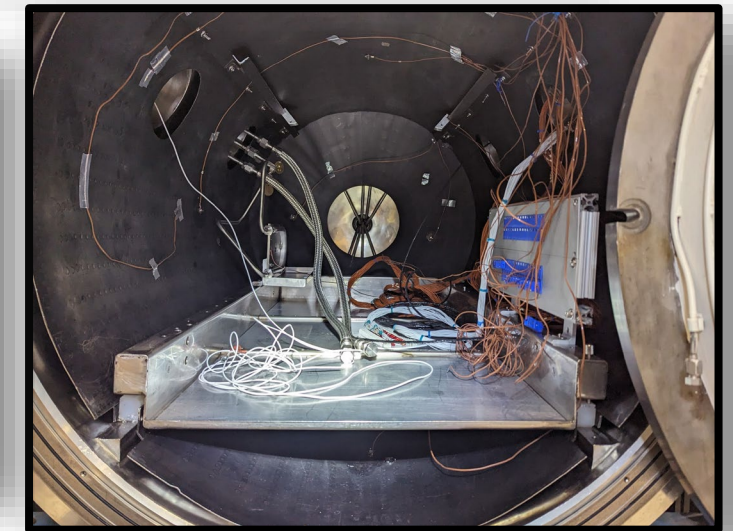
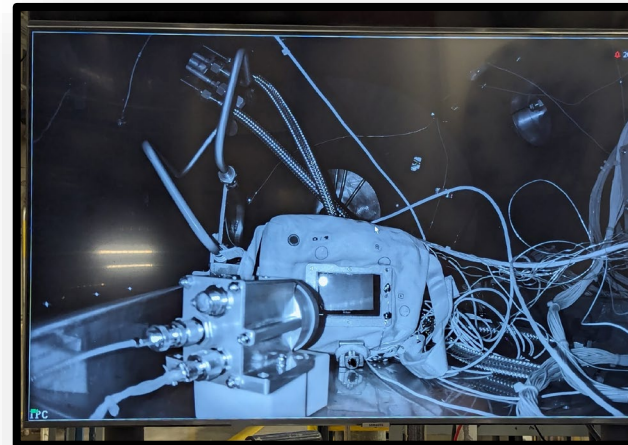

- Both operational and non-operational conditions tested
 - Non-operational was to verify survivability over an EVA duration
 - Operational conditions ensured that a simulated use case would not damage camera
- Major Assumptions for testing
 - Begin at ambient temperature
 - 50% duty cycle
 - Level orientation with view of lunar surface and deep-space (no astronaut)
 - BOL optical properties (not soiled by regolith)

Timestamp (s)	Operation(s)
0 – 30	- Power on/awake
30 – 90	- Panoramic shot - 10 x 3 shot burst - Pause
90 – 150	- 3 x 3 frame burst - Pause
150 – 270	- Powered off

Case	Lat	Solar Flux [W/m ²]	Hours post lunar sunrise	'Time' of lunar day	Equivalent Sink	Chamber Temp	Test Duration [hours]
Hot	84S	1414	212	Early afternoon	6°C	40°C	8+1
Cold	84S	1323	330	Late evening	-80°C	-120°C	8+1
PSR	84S	0	576	NA	-203°C	-190°C	2+1

• Temperature Profiles – Video mode operations

- Plot shows temperature profiles during video mode tests
- Consistent storage cards across tests
- Simulation of IVA environment
 - Microgravity (no natural convection)
 - No blanket
 - Battery powered operation

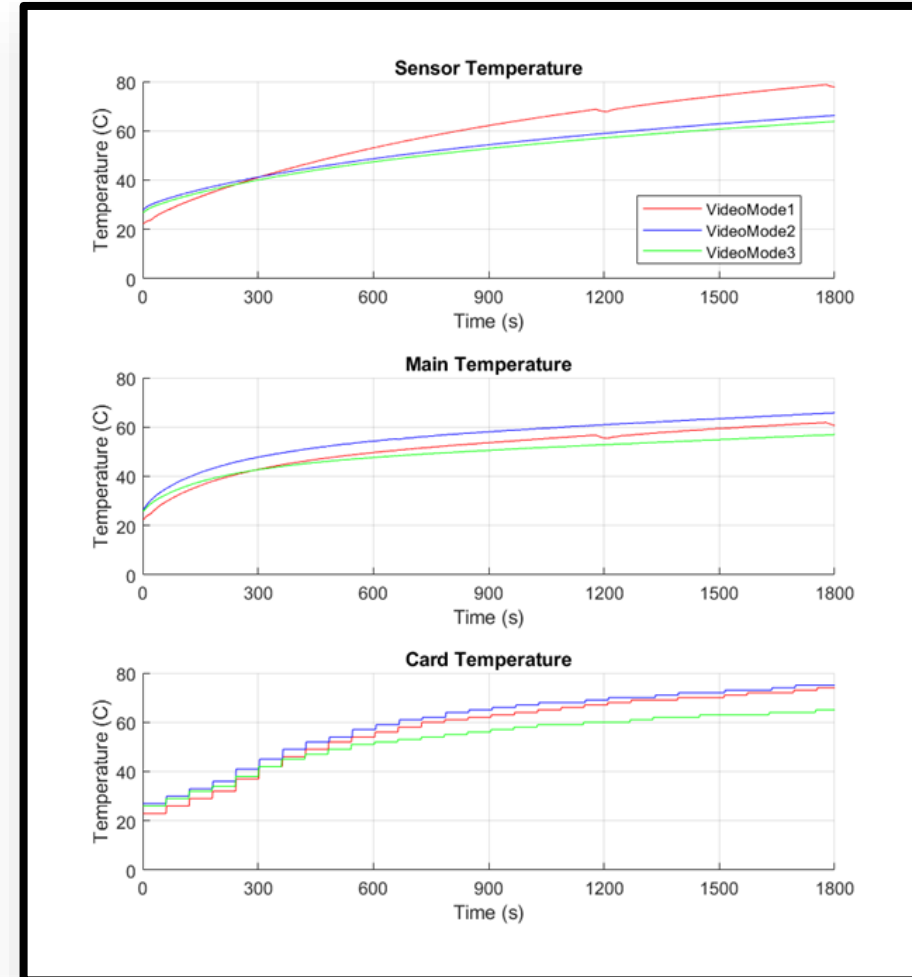

- **Temperature Profiles – Simulated Surface Environments**
 - Consistent configuration (blanket on, battery stand-in, firmware settings)
 - Survival – HULC in standby
 - Operational – 50% duty cycle
 - 8+1 hour test cycle for hot and cold cases
 - 2+1 hour test cycle for PSR
 - Hot operational shut down early in this test due to temperature limits being reached

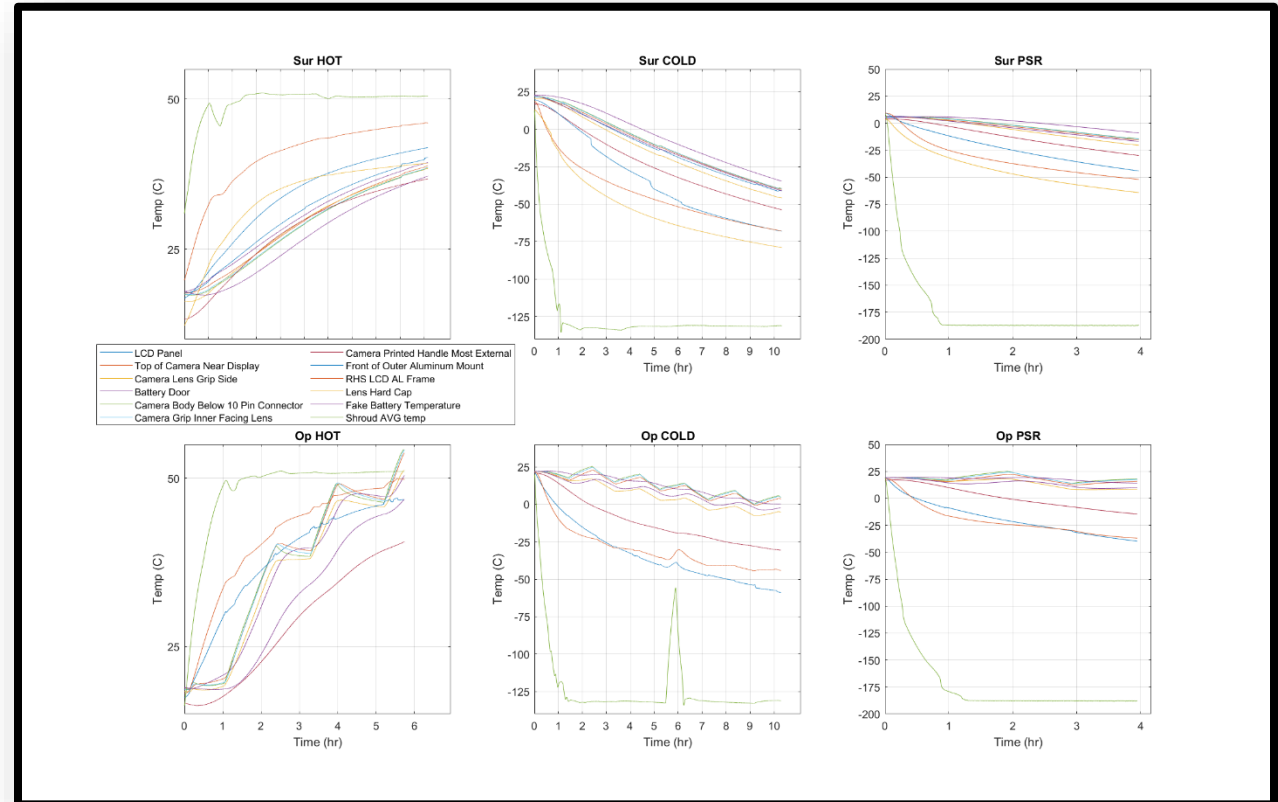



Operational Lessons Learned



- **Impact of Environmental Extremes**
 - LCD screen 'ghosting'
 - Occurred after long periods of LCD off at colder temperatures
 - Typically experienced when LCD temperatures were below -15 degC
 - Difficult to characterize quantitatively (duration and severity)
 - Never resulted in the camera unable to perform photography
 - Overtemperature warnings and camera shutdowns
 - Occurred during hot cycles due to HULC internals not able to shed heat
 - Mirrorless camera live view uses main sensor
 - Extra heat generated, even if data is not being recorded
 - Camera has built in overtemperature protections
 - Alert icon, shutdown countdown, auto shutdown

- **Effectiveness of Thermal Protection System**

- Thermal blanket is effective at protecting HULC from lunar surface temperatures
- Further insulation/protection from environment may lead to further problems
 - Camera maintains operation in cold environments and increased usage raises internal temperatures to more suitable temperatures
 - If camera failed due to under-temp conditions, unlikely to self recover
 - Due to built in firmware temperature shutdowns, battery is unlikely to reach temperatures that would cause thermal breakdown (18650s)
- Blanket is also suitable for protection from regolith
- Astronauts approved of design and are able to use easily



Credit: nasa.gov

- **Thermal Desktop Model**

- Comprised of FD surfaces and solids
- MLI uses combination of e^* and stack manager to simulate different layers at bottom of blanket
- Heat loads controlled by symbol manager and logic
 - Allows for different duty cycles, cyclical or interrupted cycles
 - Heat loads spread across surface, not nodal based

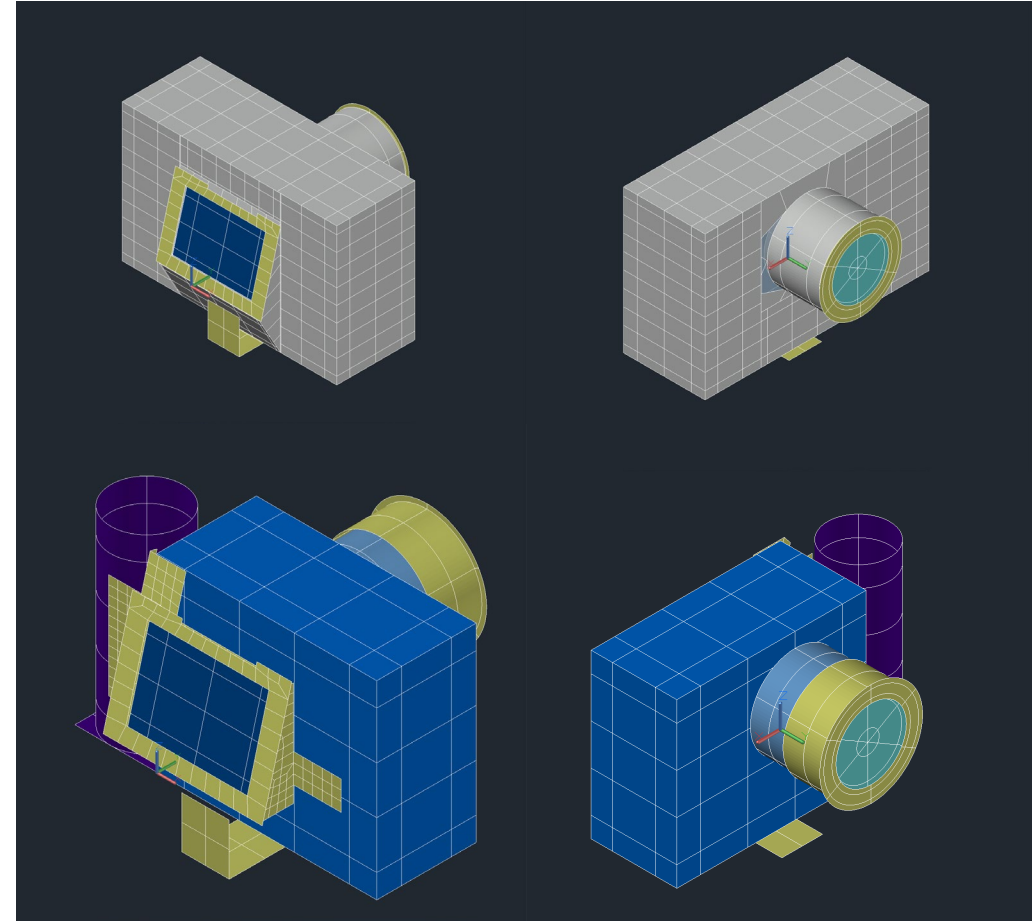

- Thermal Desktop model correlation results

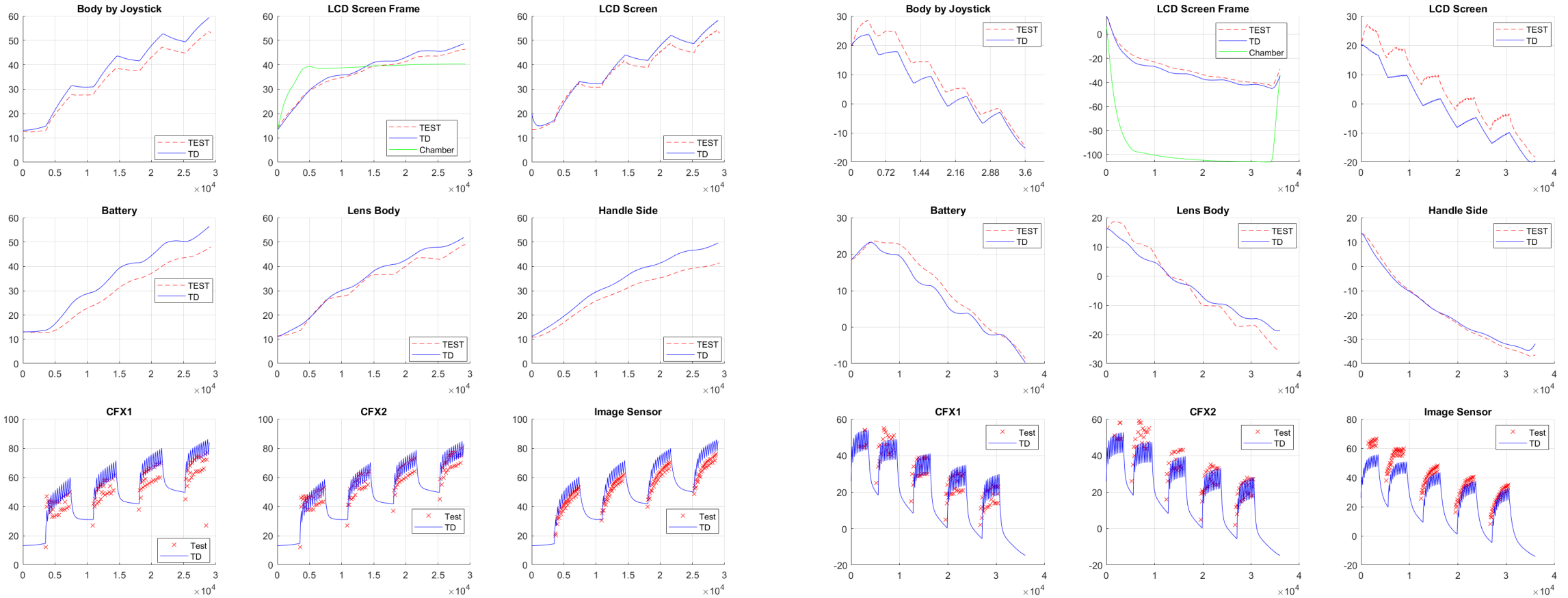



Comparison with Expected Lunar Conditions



- Current TVAC testing was done with a large amount of margin on expected temperatures
 - Validation that blanket provides adequate protection
 - Provides certainty to unknown usage cases
- Future TVAC testing will more closely simulate lunar cases
 - TVAC temperatures closer to SLS surface temperature data
 - Operational timelines compiled from field tests

- **Takeaways**

- Thermal blanket provides sufficient protection for EVAs
 - Both from external thermal loads and regolith
- HULC survives lunar environmental conditions
- HULC is suitable for use in IVA environments (microgravity)
- Astronauts are capable of using camera even with limited mobility and dexterity of gloves
- Thermal model is capable of capturing trends of current hardware build



Credit: nasa.gov



Forward Work

- Further TVAC testing or analysis to assess impacts of the following:
 - Duty Cycle / useage
 - Regolith fouling
 - Orientation of HULC relative to spacecraft and astronaut
 - Orientation of HULC relative to sun and horizon
 - Variability in thermal blanket installation
 - Lens selection
- Capture changes due to changes in firmware and handle material

- Thank you to the following contributors
 - Nikon
 - CMC
 - MSFC: ES22, EV34, ET20, HI-TTeMP Lab, ETF
 - Softgoods Lab - JSC



Credit: nasa.gov

References

- Williams, J., Paige, D., Greenhagen, B., & Sefton-Nash, E. (2017). The global surface temperatures of the Moon as measured by the Diviner Lunar Radiometer Experiment. *Icarus*, 283, 300–325.
<https://doi.org/10.1016/j.icarus.2016.08.012>
- ESA. (2023, 10 24). Next generation Moon camera tested in Europe. Retrieved from The European Space Agency:
https://www.esa.int/Science_Exploration/Human_and_Robotic_Exploration/Next_generation_Moon_camera_tested_in_Europe
- Ugalde, V. (2024, February 29). NASA Signs Agreement with Nikon to Develop Lunar Artemis Camera - NASA. NASA.
<https://www.nasa.gov/humans-in-space/nasa-signs-agreement-with-nikon-to-develop-lunar-artemis-camera/>