



The 2024 28th Biennial ELGRA Symposium & General Assembly, Sept 3-6, 2024, Liverpool, UK

The Zero-Boil-Off Tank Experiment: the Effects of Non-Condensable Gases on Pressurization and Pressure Control of Propellant Tanks in Microgravity

Mohammad Kassemi, Sonya Hylton, Olga Kartuzova

**National Center for Space Exploration Research
Case Western Reserve University and NASA Glenn Research Center
Cleveland, OH**

Thursday, September 5, 2024

Zero Boil-Off Tank (ZBOT) Experiment Series

- The Zero Boil Off Tank (ZBOT) Experiment series is undertaken to delineate the important and fundamental Physical Phenomena that govern key propellant tank pressurization and pressure control using a small-scale *simulant*-fluid experimental investigation in the Microgravity Science Glovebox (MSG) unit aboard the ISS.
- An important goal of the investigation is to develop and validate a comprehensive Two-phase CFD model that captures the underlying physics in both microgravity and 1g.
- The ZBOT-1 Experiment flew in 2017 and collected valuable self-pressurization and jet mixing microgravity data for a pure single component system. The data was used for nearly 30 model validation case studies.
- The ZBOT-NC Experiment is scheduled to fly in early 2025 to investigate the effect of noncondensable pressurant gases on self-pressurization and jet mixing pressure control for a two-component system in microgravity.

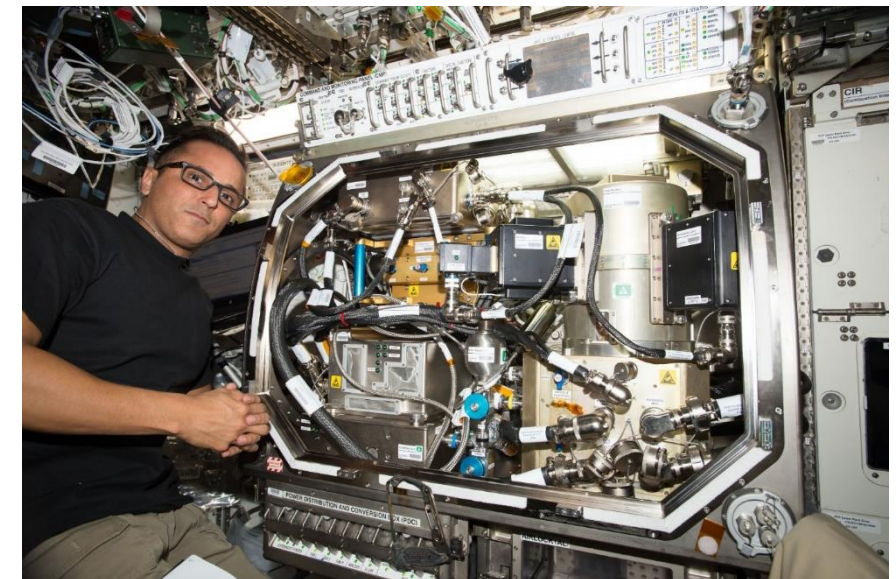
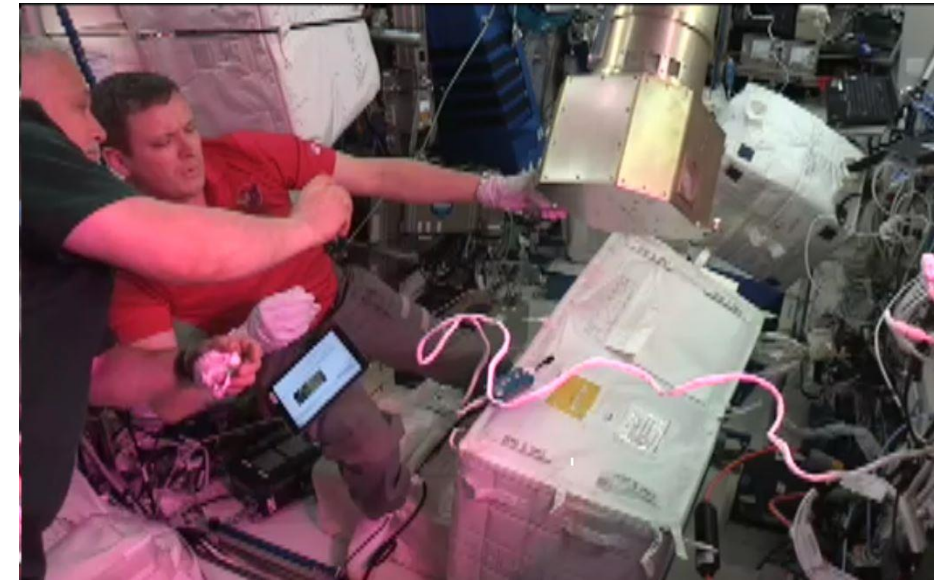

The Three Potential Effects of Noncondensable Gases At a L-V Interface

A. Introduces a **transport barrier** to vapor reaching the interface in order to condense.

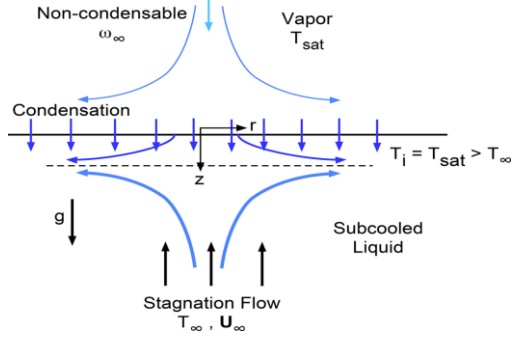

Panzarella & Kassemi (2009)

Balasubramaniam & Rame (2018)

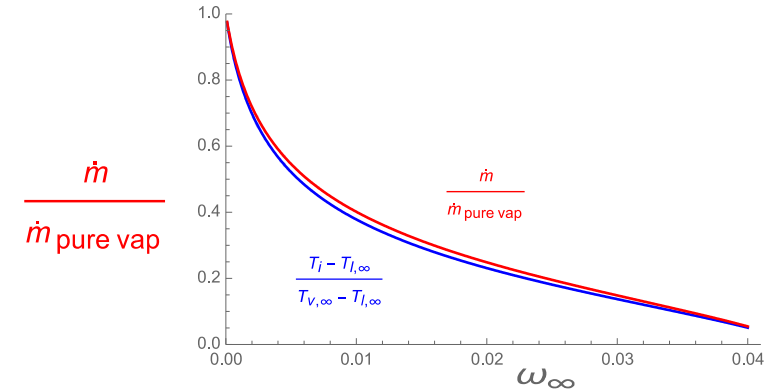

B. Penetrates in the Knudsen layer at the phase front region and creates a **kinetics barrier** to condensation mass transfer

C. Pong & Moses, PoF 29: 1802 (1986)

$$\dot{m} = 1.67 \left(\frac{P_{sat}(T_l) + 0.579 P_{nc} \left(\frac{M_{nc}}{M_v} \right) - P_v}{\sqrt{2\pi R T_v}} \right) \cdot \left\{ 1 + 0.515 \ln \left[\frac{P_v}{P_{sat}(T_l)} \sqrt{\left(\frac{T_l}{T_v} \right)} \right] \right\} \left[1 + 4.29 \left(\frac{P_{nc}}{P_{sat}(T_l)} \right) \left(\frac{M_{nc}}{M_v} \right) \left(\frac{T_l}{T_v} \right) \right]$$

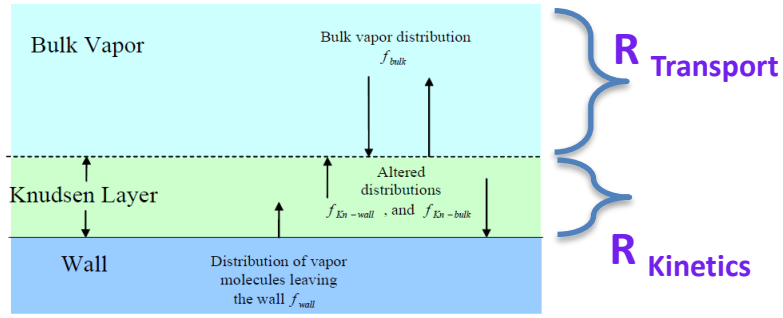
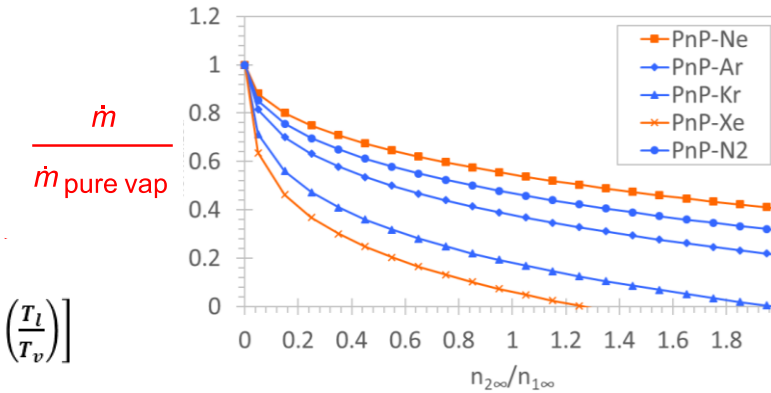

C. Generates **Marangoni convection** and changes the flow structure in the liquid impeding the cooled jet flow from reaching and spreading around the warm ullage

B. Straub, Ann. N.Y. Acad. Sci. 974: 348-363 (2002).

BDPU facility LMS Space Shuttle mission (1996)

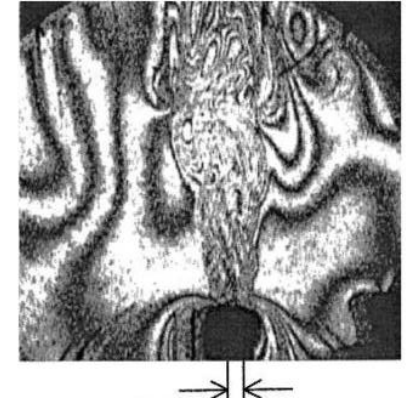
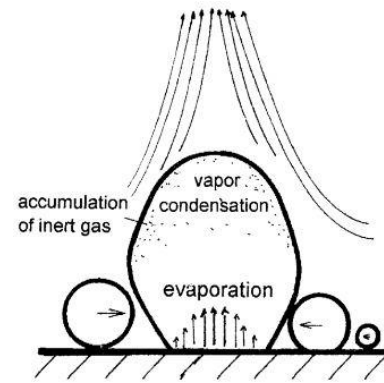

ZBOT-NC Experimental Setup and Description

Perfluoro-n-Pentane

(PnP, or C₅F₁₂) n-Isomer (Straight Chained) Chemical Structure

- Test Cell & Test Fluid
- Test Cell Thermal Control
 - Vacuum Jacket
 - Test cell heating
 - Initial test conditions
- Liquid Jet Mixing/Cooling
 - Fluid Reservoir & Degassing Contractor
 - Local Temperature & Pressure Measurements
 - Ullage Imaging – Location & Deformation
 - Quantum Dot Thermometry
 - Noncondensable Gas Injection: Xenon & Neon
 - **Transport:** Similar mass diffusivities
 - **Kinetics:** Different molecular weights

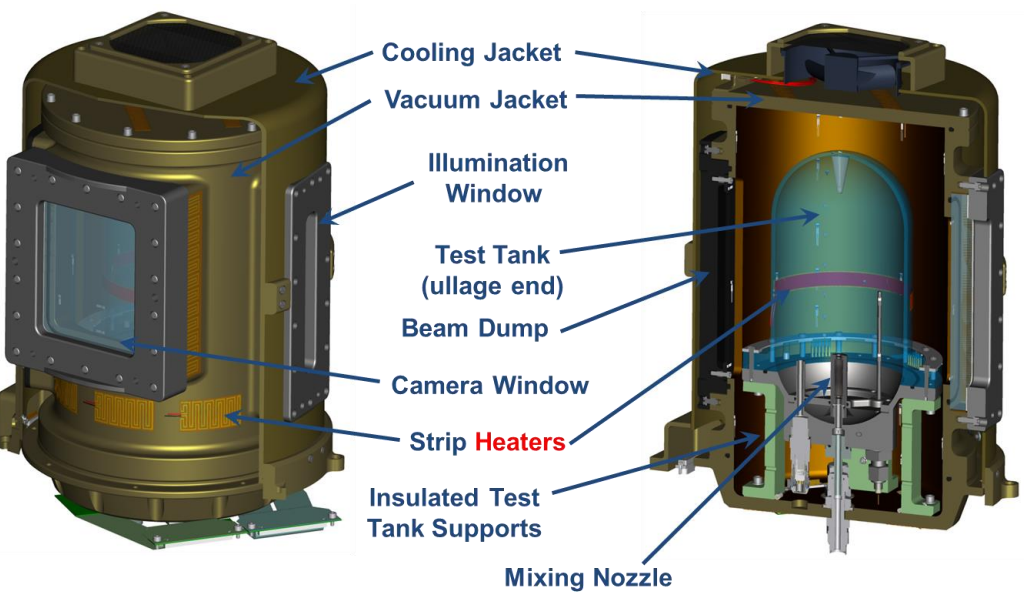
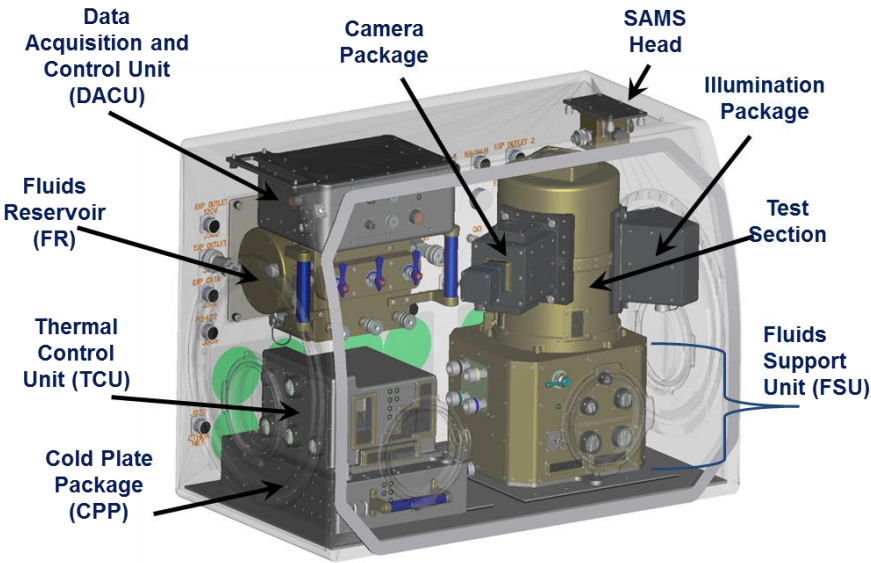

Type of Test	Method & Mode
Pressurization	Heater Strip
	Vacuum Jacket Heating
	Heater and Vacuum Jacket
Subcooled Mixing	Uniform Temperature
	After Self-Pressurization

Outputs as Time Evolution
Pressure
Fluid Temperature (6 locations)
Wall Temperature (17 locations)
Jacket Temperature (21 locations)
Jet Shape and Movement (LED Light)
Temperature Field Contours (QDT)

Test Matrix: 65% Fill Level pressurization, pressure control, and jet-ullage interaction tests



37 Self-Pressurization Tests

	Heating Mode	Duration (hours)	NCG	Mole Fraction
Vacuum Jacket	$T_{VJ} = T_{\text{tank}} + 1K$	4	Neon	$x_g = 0$
	$T_{VJ} = T_{\text{tank}} + 2K$	4		$x_g = 0.02$
Tank Heaters	0.2W	12		$x_g = 0.10$
	0.4W	5		$x_g = 0.25$
	0.8W	5		Xenon
		$x_g = 0.02$		
		$x_g = 0.10$		
		$x_g = 0.25$		

Self-Press Tests to be followed by Jet tests ($T_{\text{jet}} = T_0 - 6^\circ\text{C}$ at 4 cm/s for 1 hour)

117 Subcooled Jet Tests from T_0

$T_{\text{Jet}} (^\circ\text{C})$	$v_{\text{Jet}} (\text{cm/s})$	Duration (hours)	NCG	Mole Fraction
$T_0 - 1$	2, 4, 10, 20	1	Neon	$x_g = 0$
				$x_g = 0.02$
				$x_g = 0.05$
				$x_g = 0.10$
$T_0 - 3$	2, 4, 10, 20	1		$x_g = 0.25$
				$x_g = 0$
			$x_g = 0.02$	
			$x_g = 0.10$	
$T_0 - 6$	2, 4, 10, 20	1	Xenon	$x_g = 0.05$
				$x_g = 0.10$
				$x_g = 0.25$
				$x_g = 0$
				$x_g = 0.02$
				$x_g = 0.25$

8 Jet-Ullage Interaction Tests

Duration: 2 minutes

Only the first test starts at T_0

$T_{\text{Jet}} (^\circ\text{C})$	$v_{\text{Jet}} (\text{cm/s})$	NCG	Mole Fraction
$T_0 - 1$	2	Xenon	$x_g = 0$
$T_0 - 2$	4		
$T_0 - 3$	10		$x_g = 0.25$
$T_0 - 4$	20		

65% FL: 162 tests

55% FL: 62 tests

75% FL: 162 tests

ZBOT-NC CFD Model Prediction of Non-Condensable Gas Effects in 1G



Time = 0.0 minutes

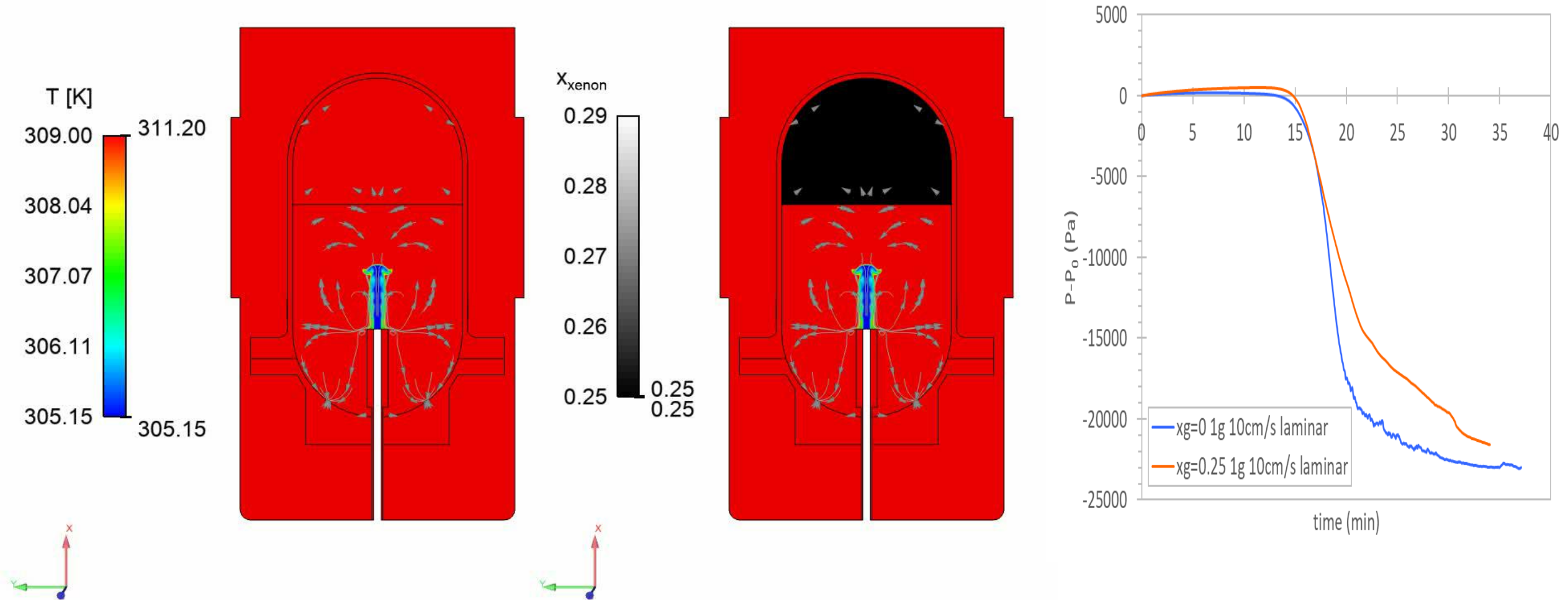

ZBOT-NC CFD Model Prediction of Non-Condensable Gas Effects in Microgravity

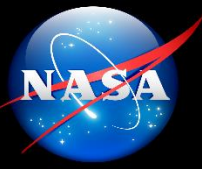

Pure Vapor

Vapor and NCG

Time = 2 s

Time = 2 s

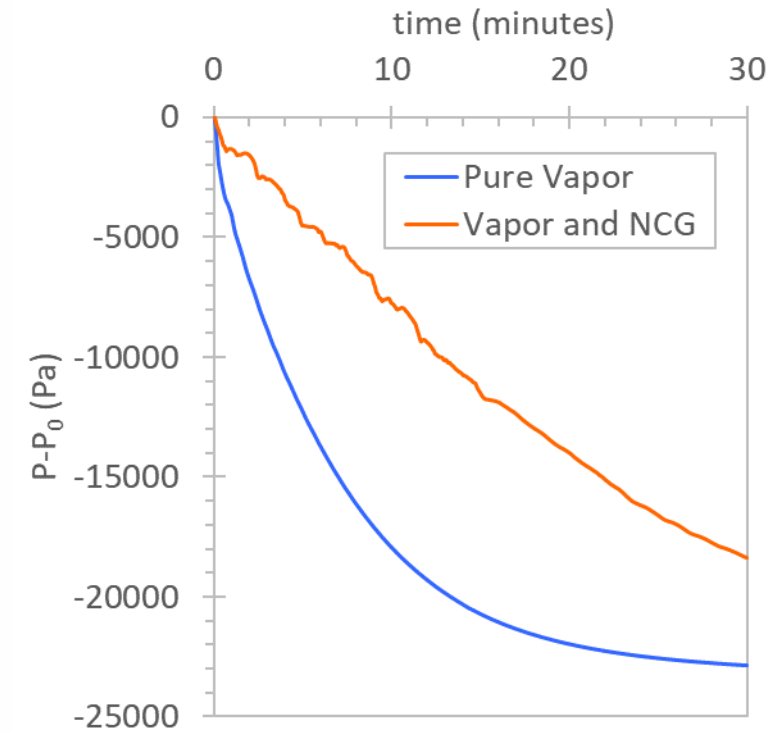
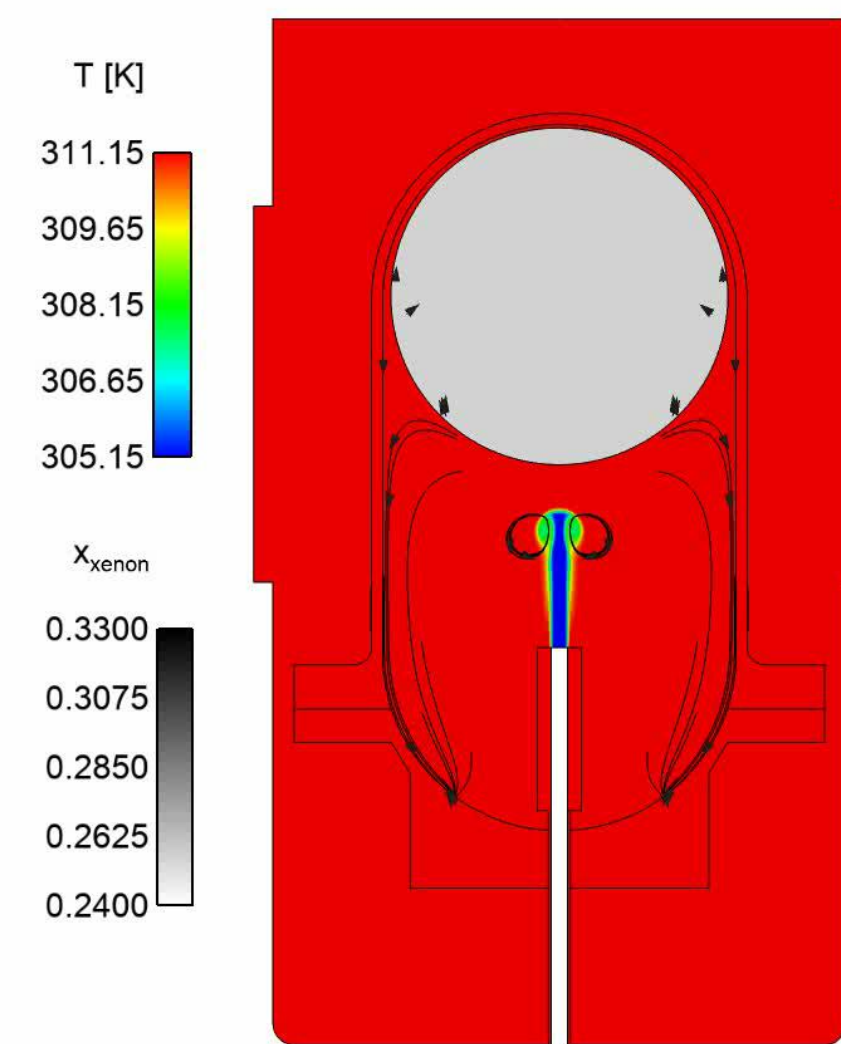
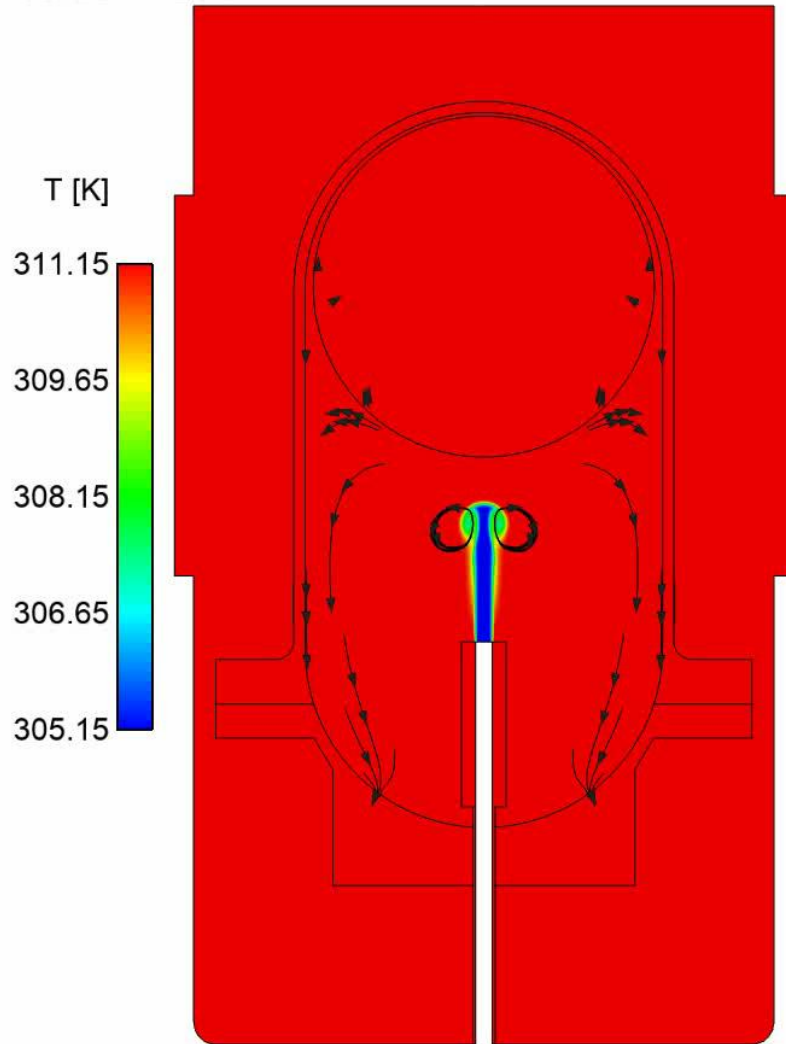

CFD vs. Pressure and local RTD sensor data

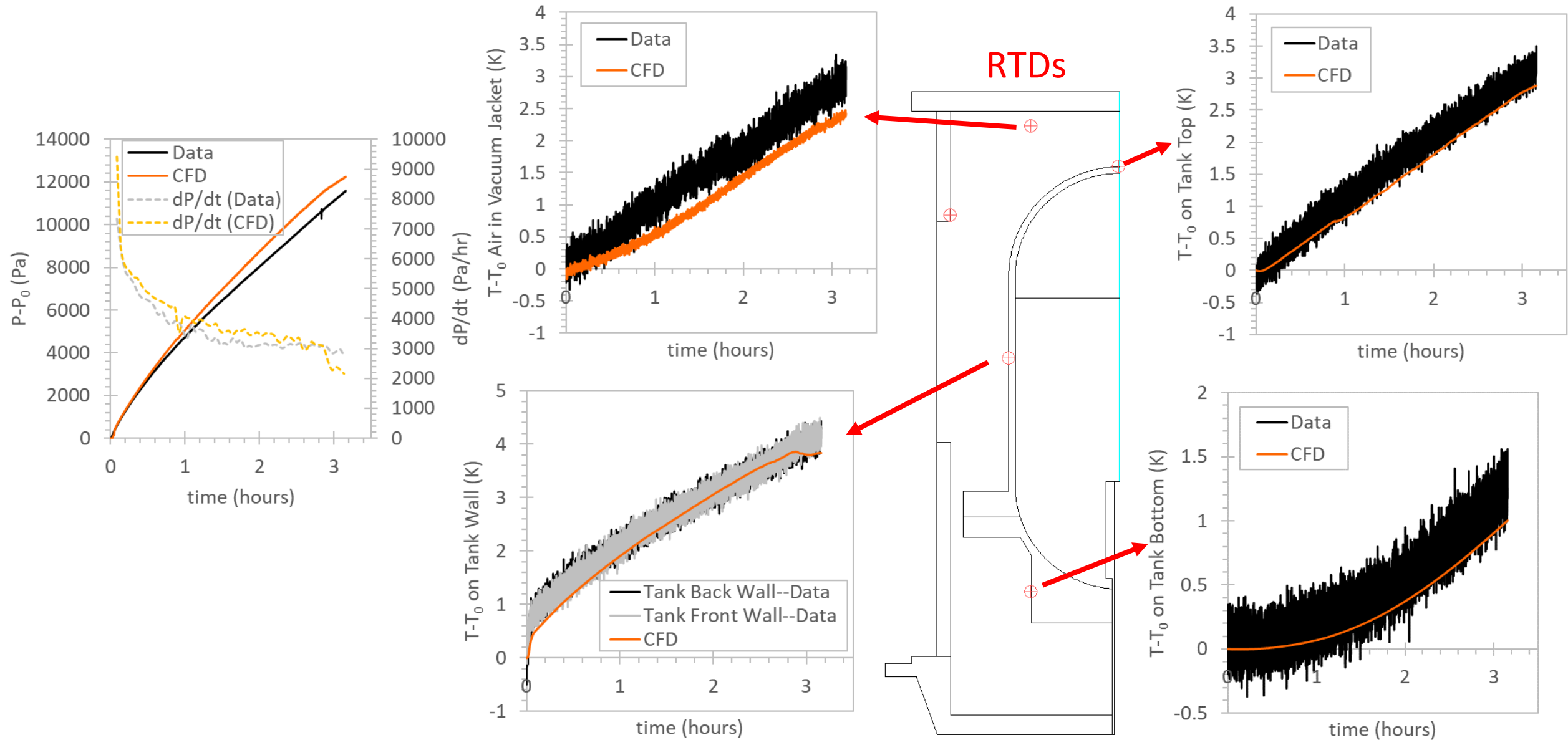

Quantum Dot Thermometry

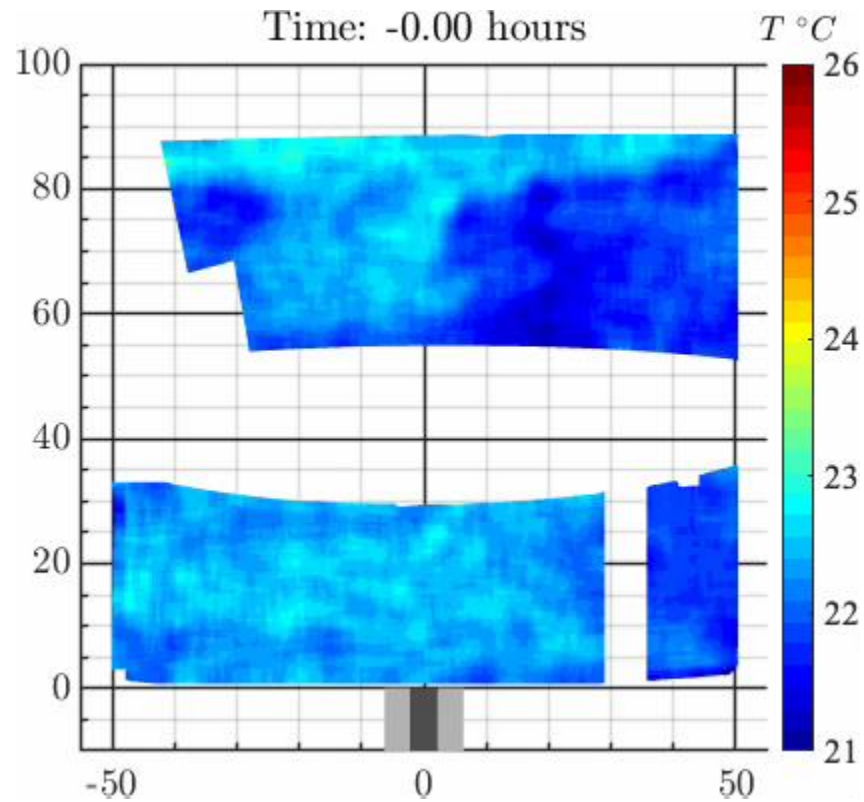

Time = 0.00 hours

CFD Prediction

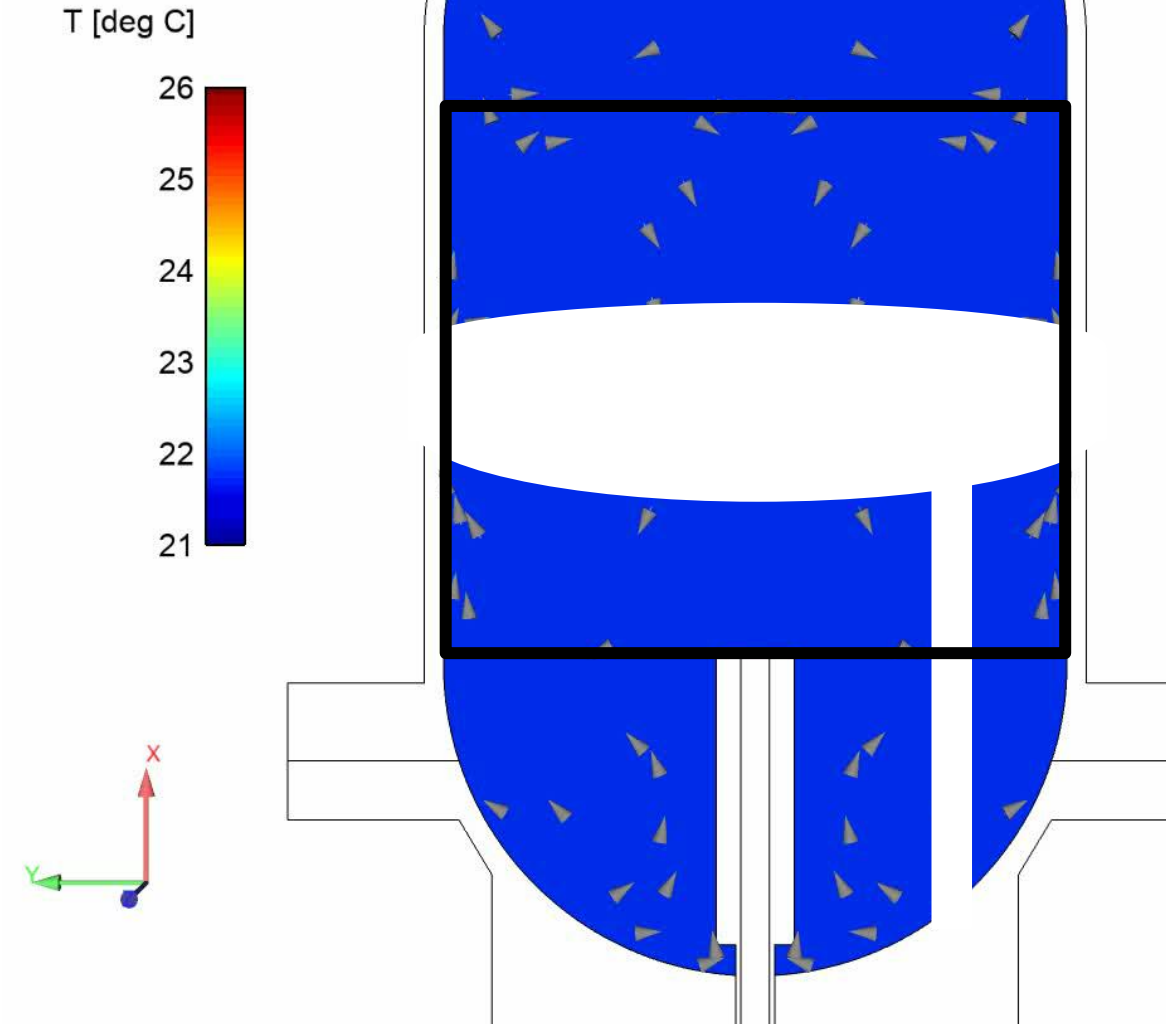

Comparison of Temperature Contours: QDT Data versus CFD Prediction



1.25 Hours

QDT

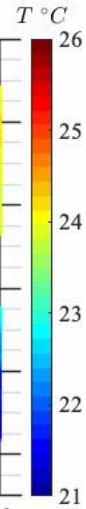
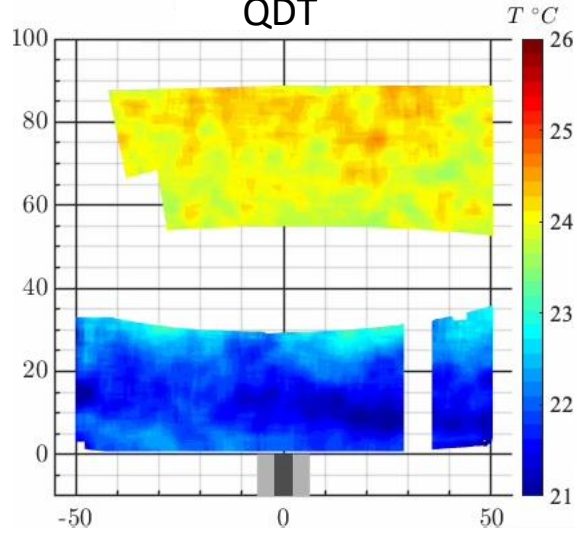

CFD

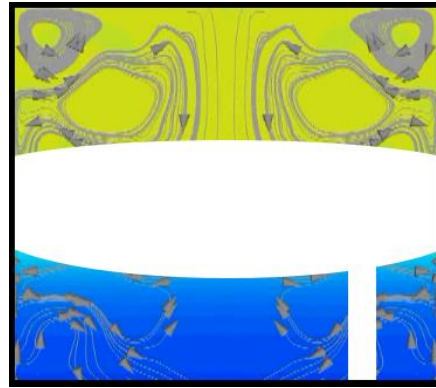

2 Hours

QDT

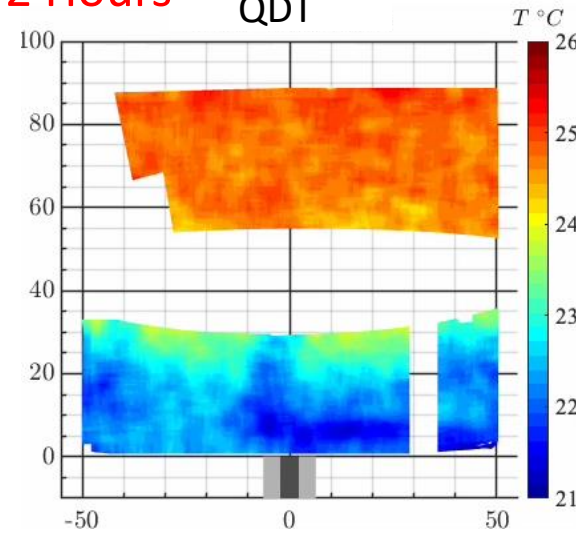

CFD

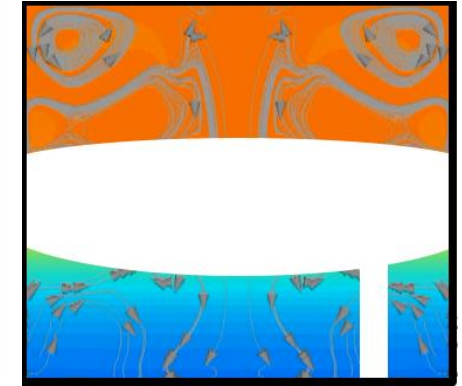

2.75 Hours

QDT

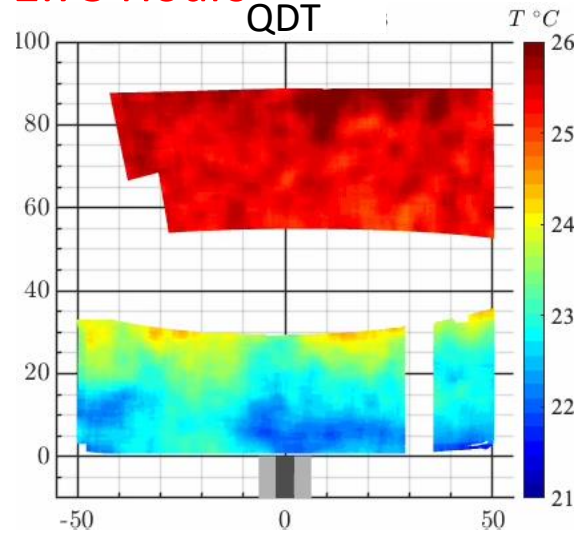

CFD

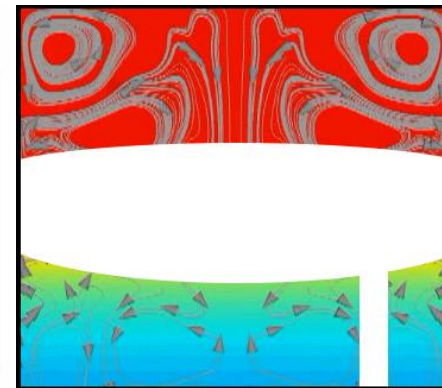

Temperatures along vertical lines in the liquid (QDT vs. CFD)

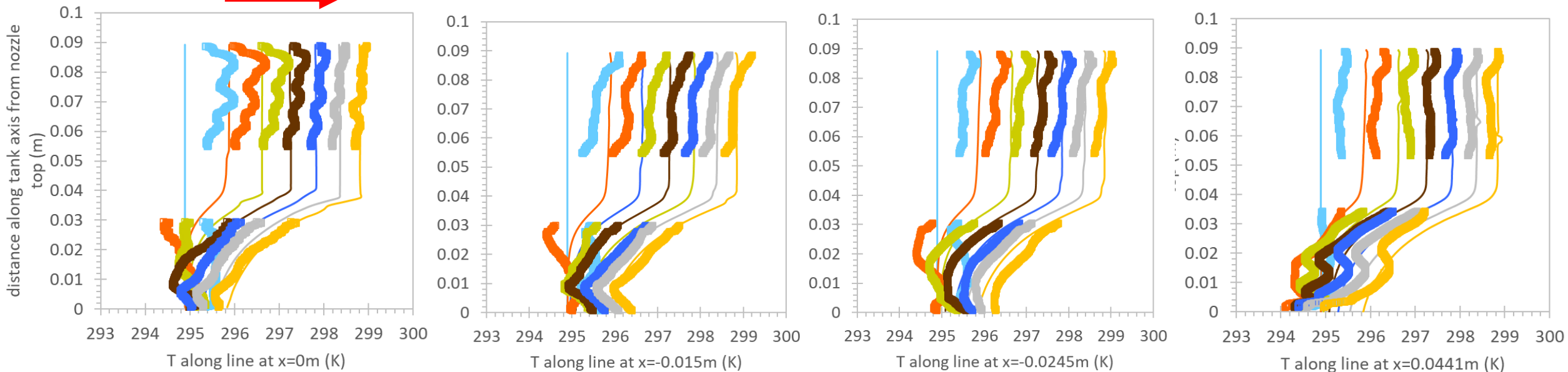
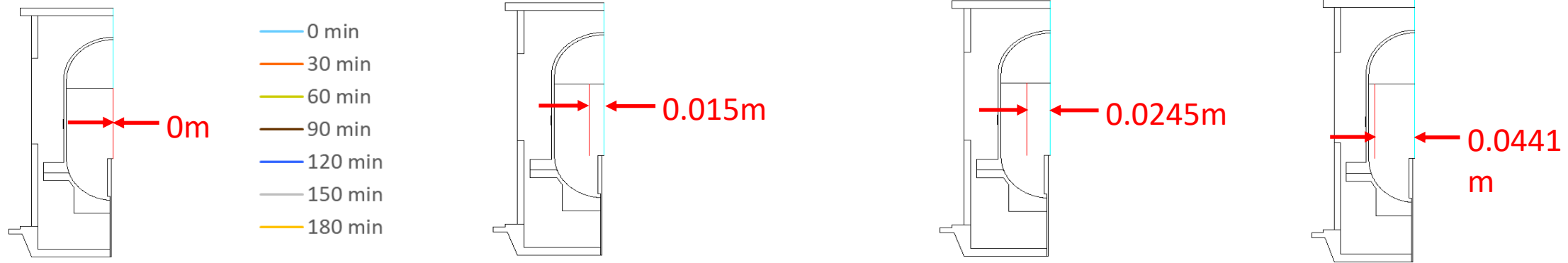

Temperature Evolution at Different Points in the Liquid (QDT vs. CFD)

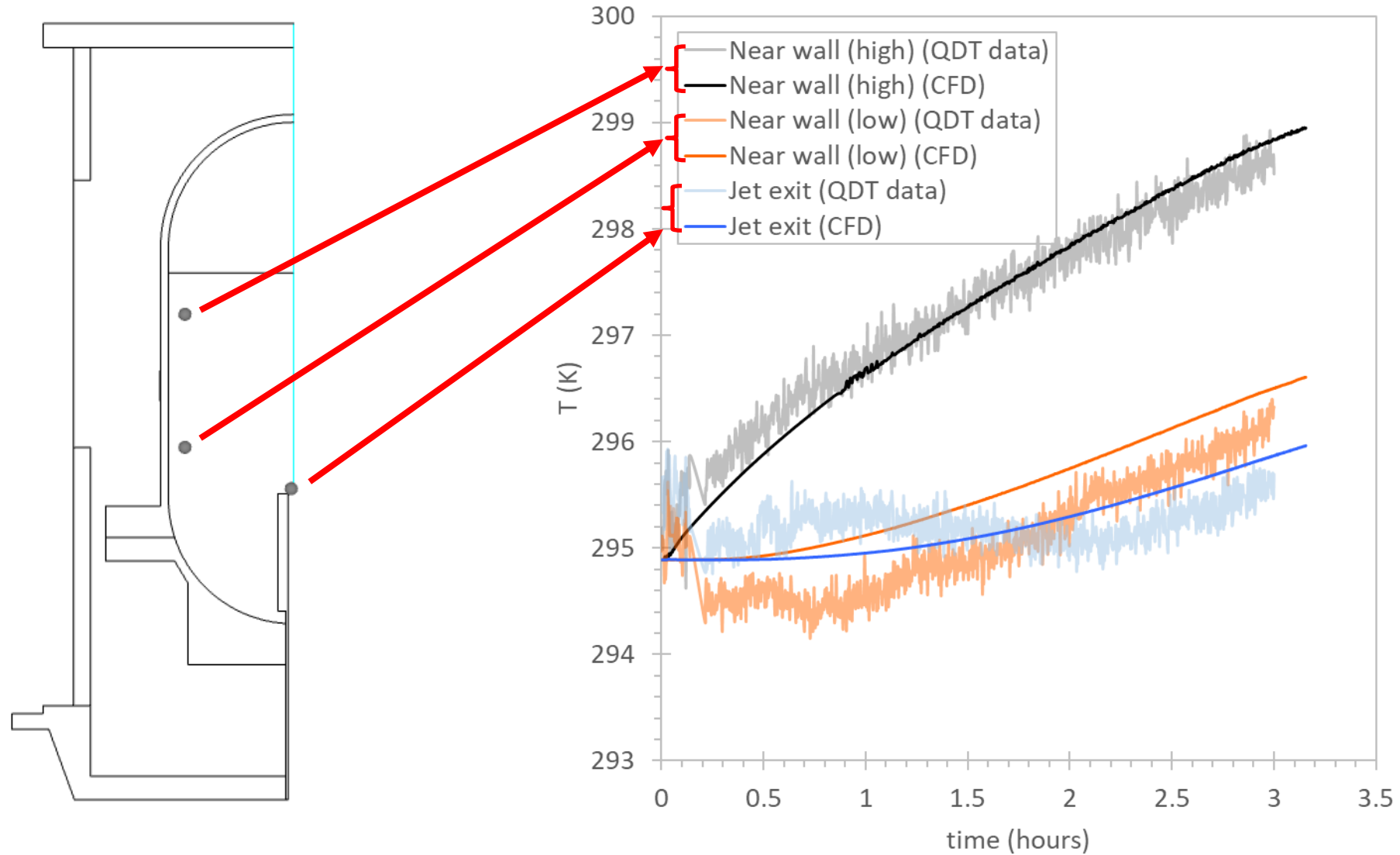

The main goal of ZBOT-NC experiment is to determine **impact of a non-condensable pressurant gas** on the evaporation/condensation and transport processes that affect tank pressurization and pressure control in microgravity

In order to **accomplish this objective**, and provide **high-fidelity data for model validation**, we need to capture the **temperature field in the liquid**

In the preliminary ground-based results shown in this presentation, we have partially **validated both the computational model and the QDT diagnostic's fidelity**

Further validations for the jet mixing part of the experiment are underway

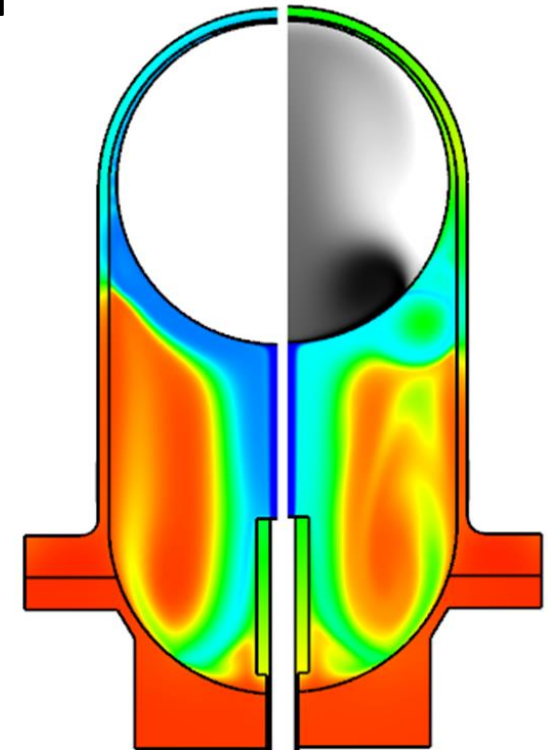

Acknowledgment



Funding and programmatic support from the NASA Microgravity Biological and Physical Sciences (BPS) Division at NASA Headquarters through the ZBOT Experiment science investigations are gratefully acknowledged.



Backup Slides

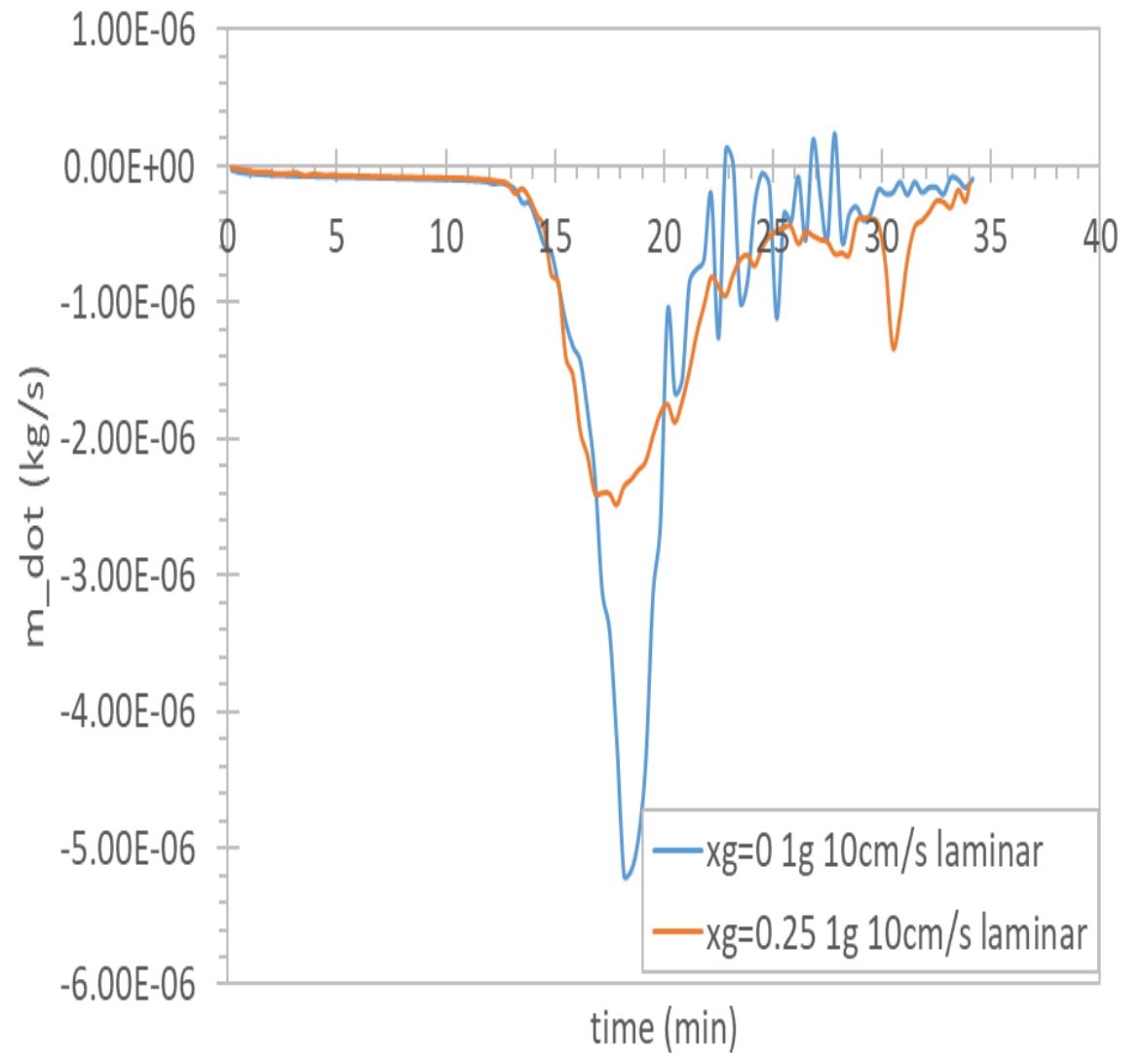
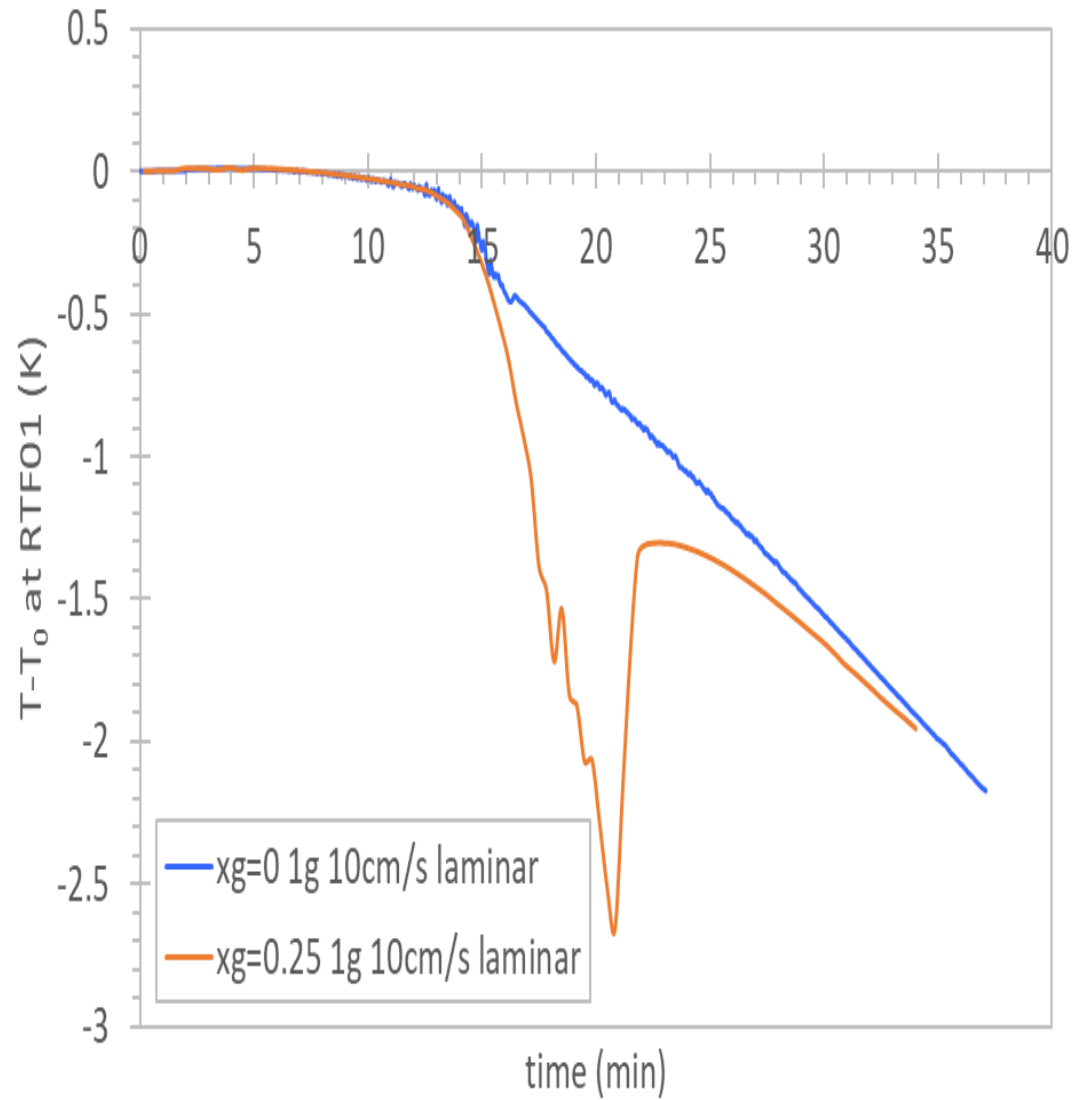

Effect of Noncondensable Pressurant Gas on Tank Pressure Control



1G LH2 Tank Pressurized with GH2 & GHe and Depressurized with a Subcooled Jet (Lockheed 1969)

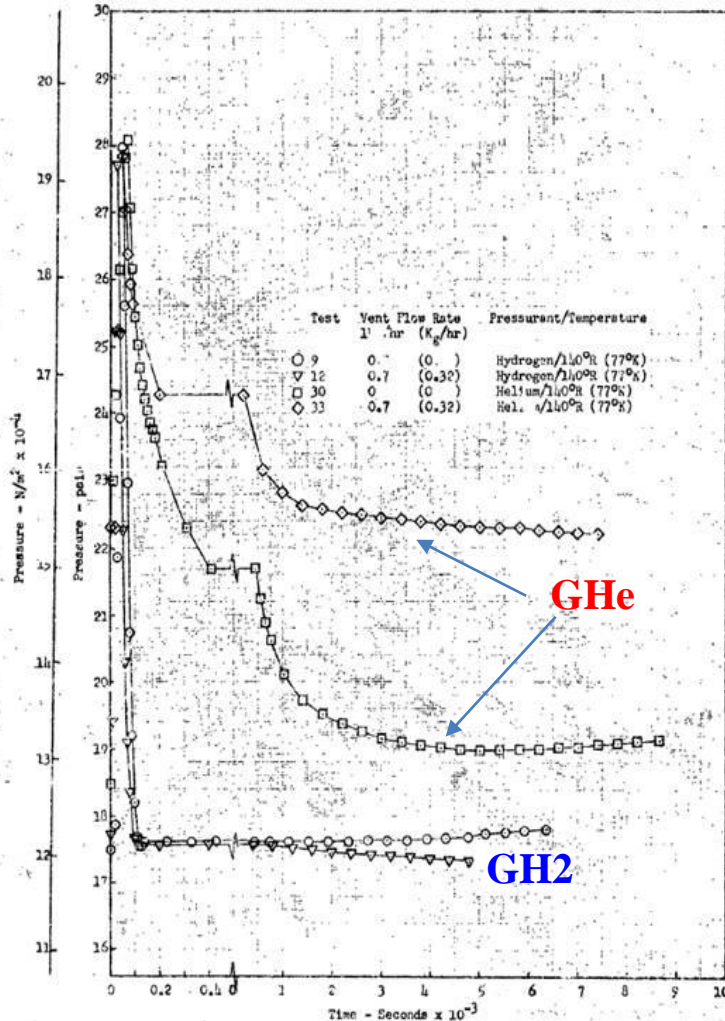
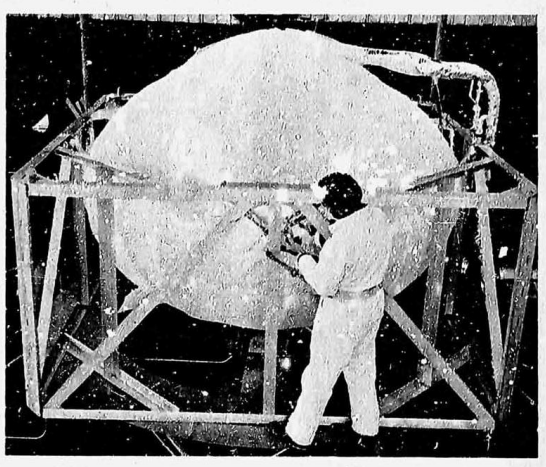

1G LN2 Tank Pressurized Slosh Experiments (University of Tokyo, 2019)

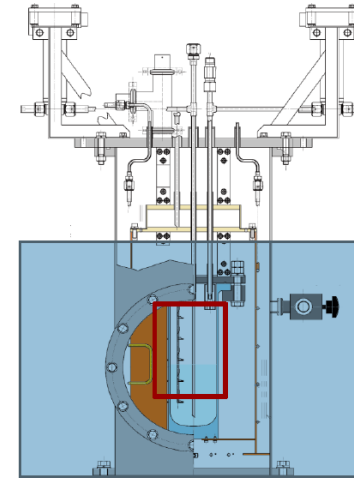

Constant Amplitude

- Cylindrical polycarbonate vessel (ID = 0.105 m)
- Filled with LN2 pressurized with GN2 or GHe
- Periodical sloshing caused by lateral external sinusoidal oscillation: 2.45 Hz – 10 mmp-p

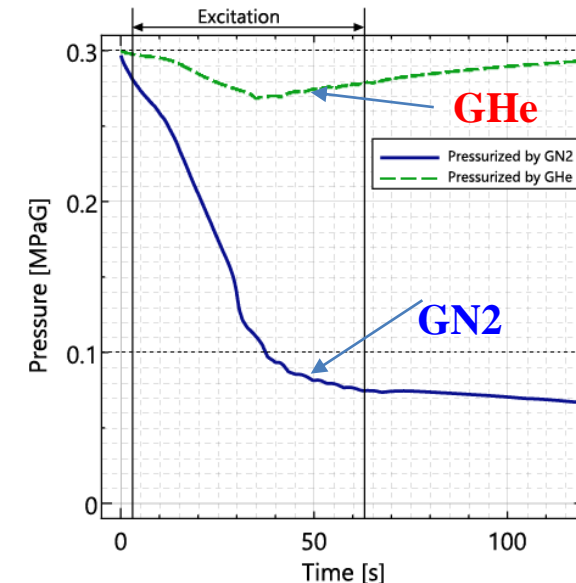

- LH2 Pressurized with like (GH2) and NCG (GHe)
- 110 in – 2.8 m Tank
- Depressurization by mixing alone using bottom- and side-mount nozzle/pump and by mixing and cooling using a TVS system
- Results for 95% FL – Bottom Mount
- Mixer flow rate 5.3 cfm – 150 L/min
- Effect of Mixing, Cooling, NCG

Bullard, B. R., "Liquid Propellant Thermal Conditioning System Test Program," NASA CR-72971, 1972

Liquid Propellant Thermal Conditioning System Test: (Lockheed 1972)

- LH2 Pressurized with like (GH2) and NCG (GHe)
- 110 in – 2.8 m Tank
- Depressurization by mixing alone using bottom- and side-mount nozzle/pump and by mixing and cooling using a TVS system
- Results for 95% FL – Bottom Mount
- Mixer flow rate 5.3 cfm – 150 L/min
- Effect of Mixing, Cooling, NCG

Bullard, B. R., "Liquid Propellant Thermal Conditioning System Test Program," NASA CR-72971, 1972

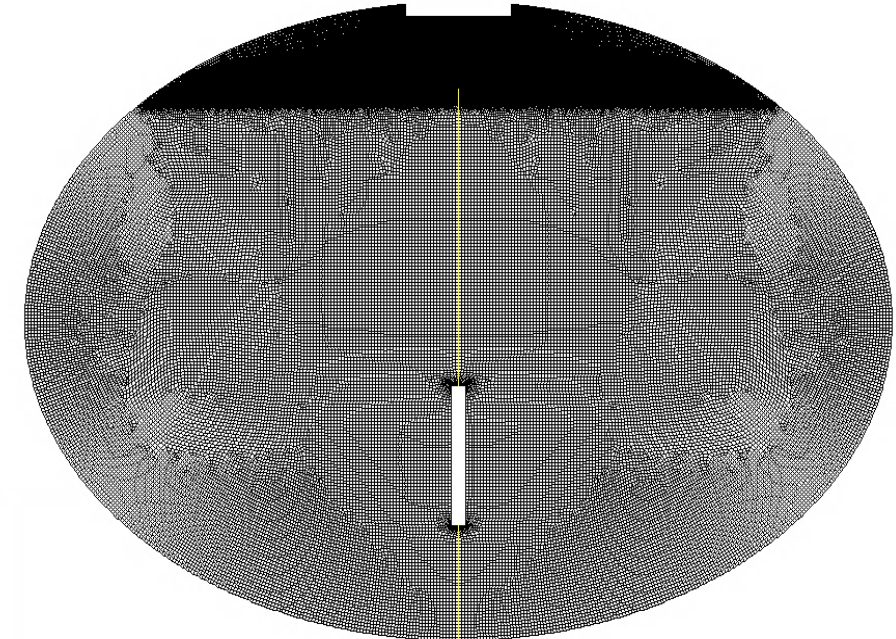
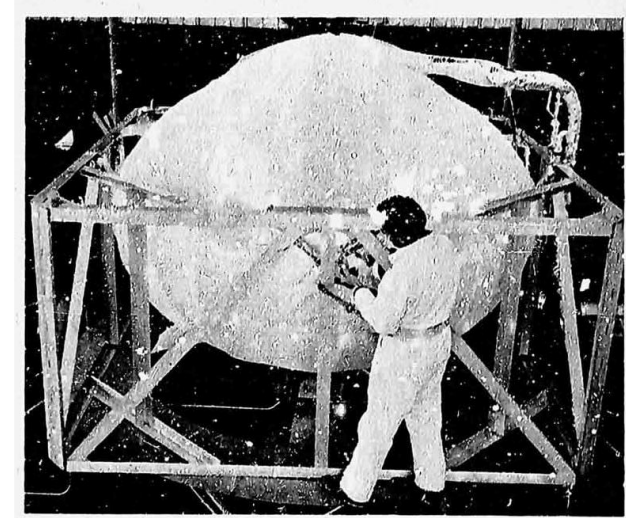
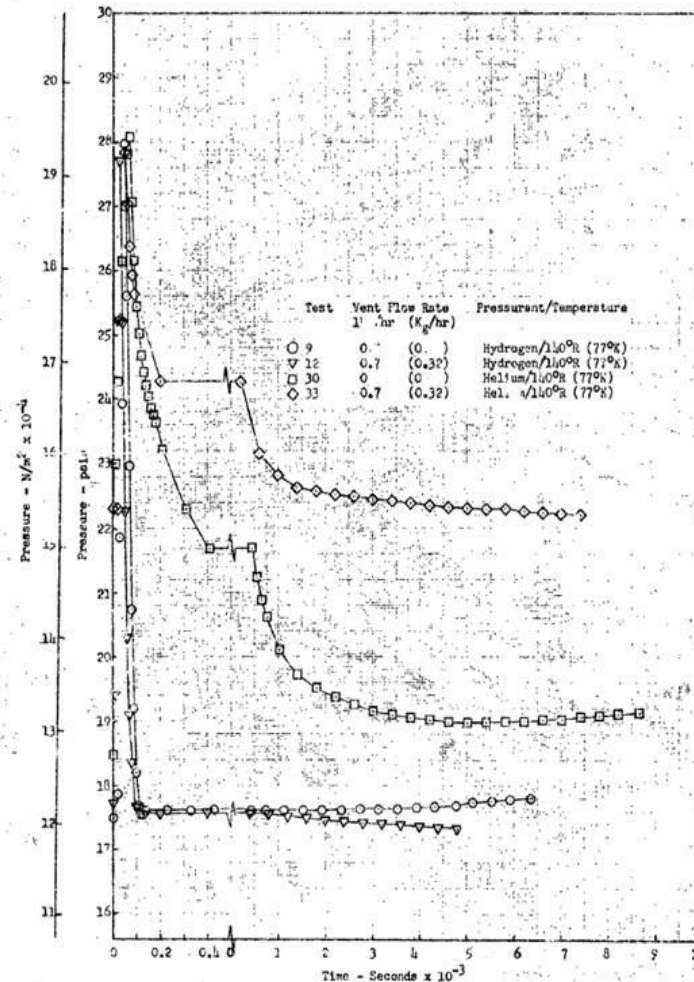

Validation of Noncondensable CFD Model against Bullards -1 G data

- Pressurization
- Ullage Volume 5%
 - Initial tank pressure = 17.49 psia = 0.1205893 MPa
 - Pressurize with GH₂ or GHe
 - Pressurant gas temperature = 77 K
 - Gas Injection Rate – 1.83 g/sec (from TD model)

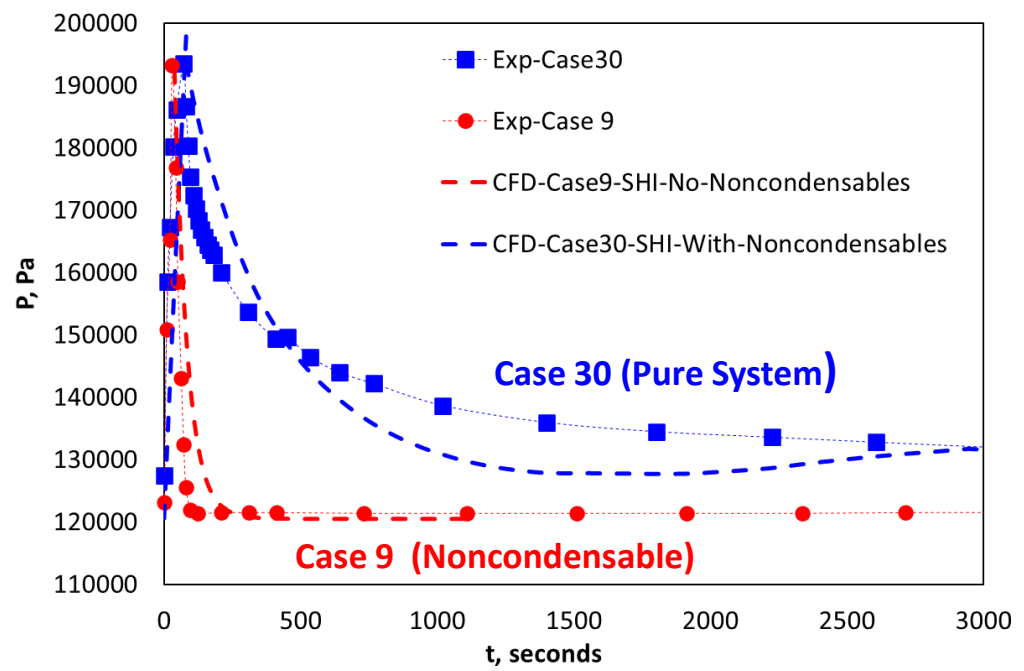
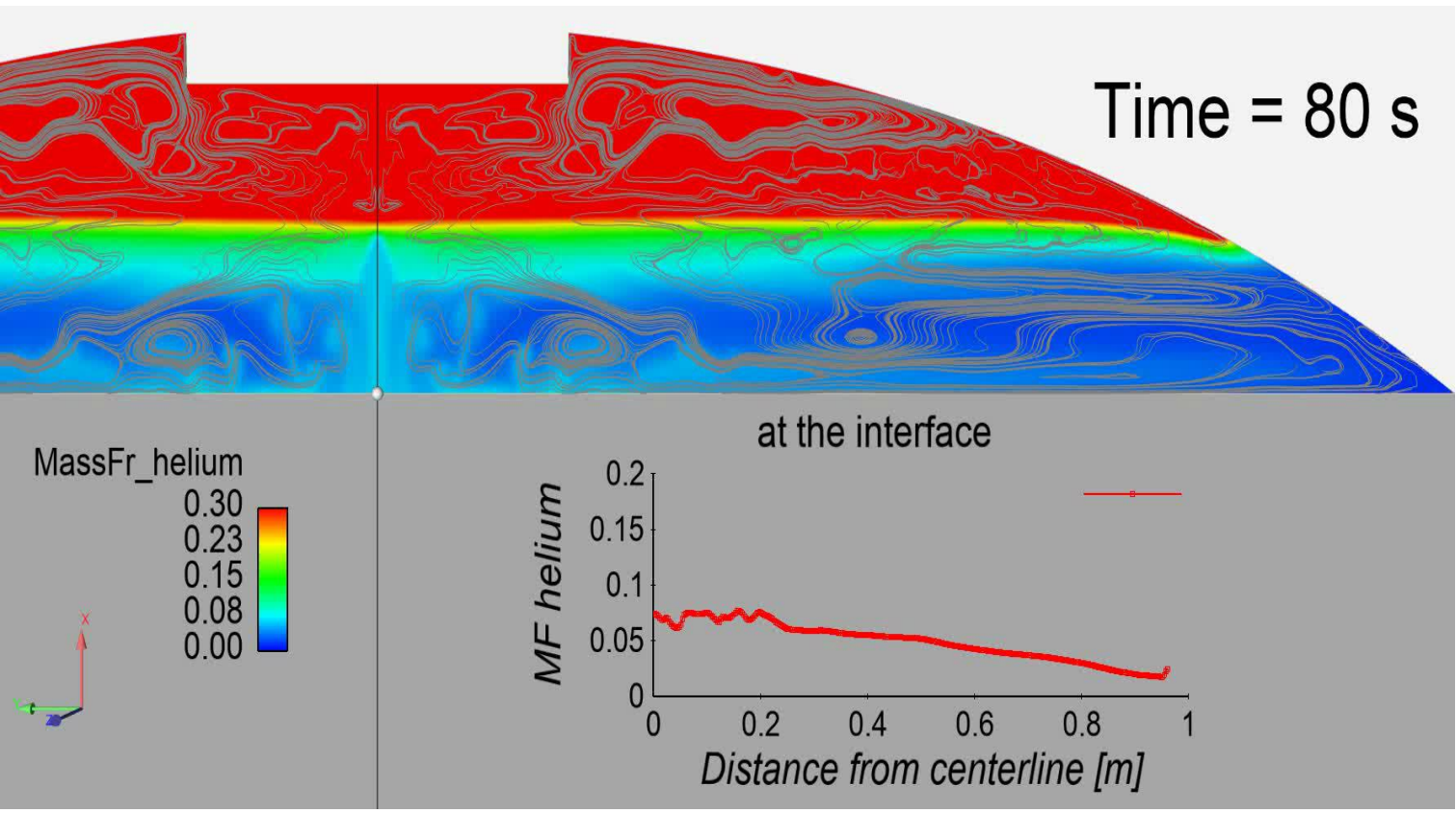

- Mixing
- IC: End of Pressurization
 - Mixer Flow = 150 L/m = 0.17532 kg/s
 - Tank pressure before mixing = 28 psia
 - Mixing nozzle diameter = 0.04445 m

ZBOT Hardware components

Vacuum Jacket

Camera

Laser



Acrylic tank top

Heaters

Nozzle

Tank bottom

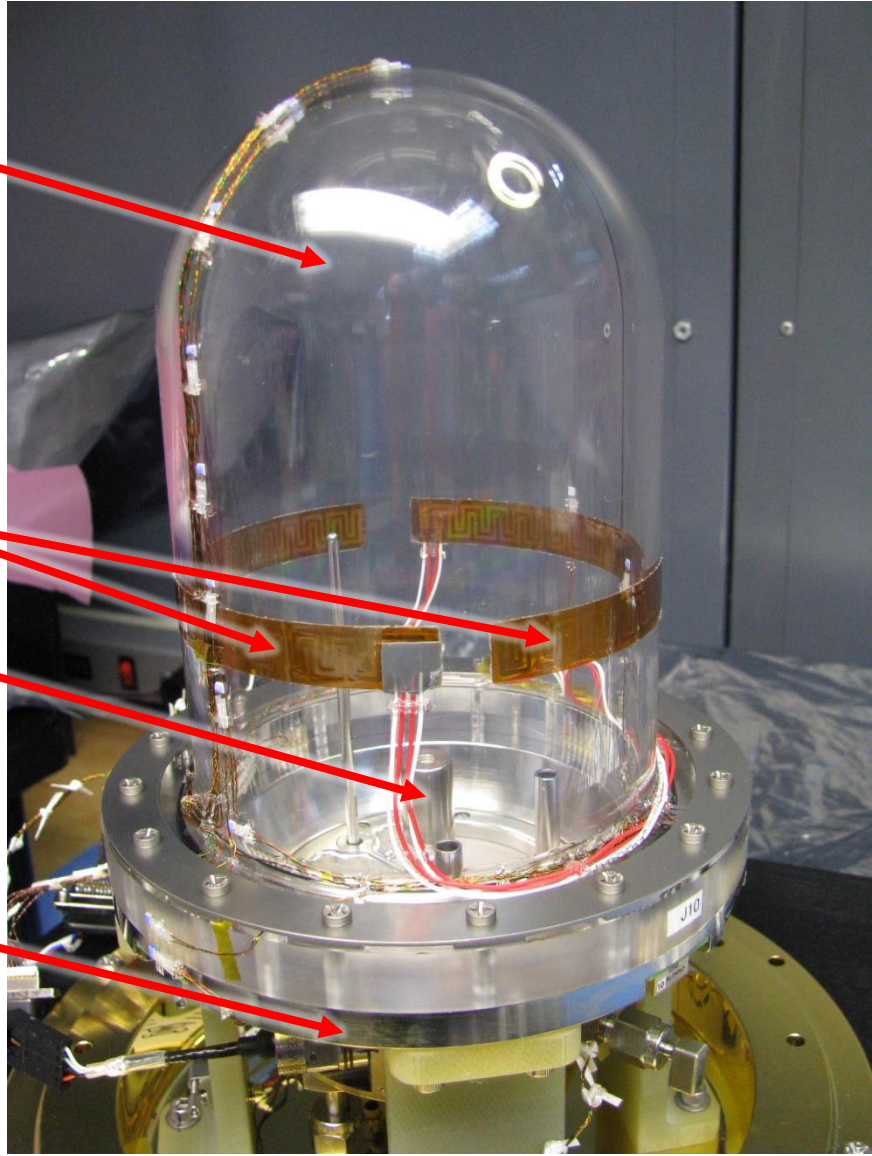

Hardware

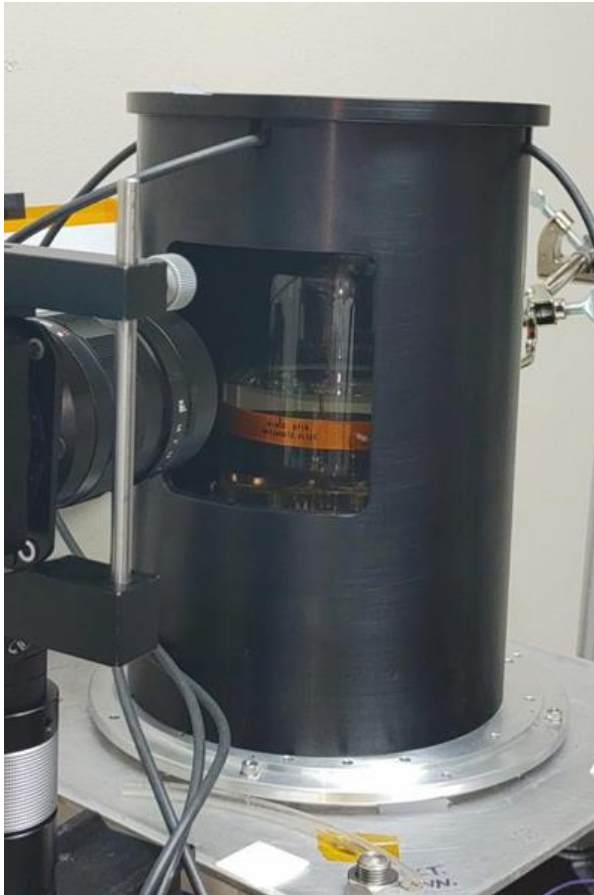

CAD model

Vacuum Jacket and air

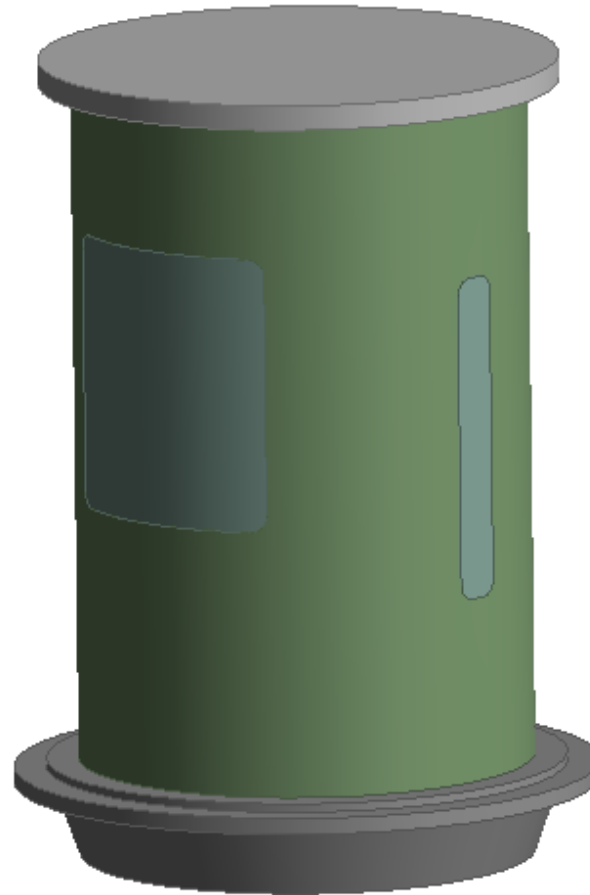

Vacuum Jacket Bottom and Tank

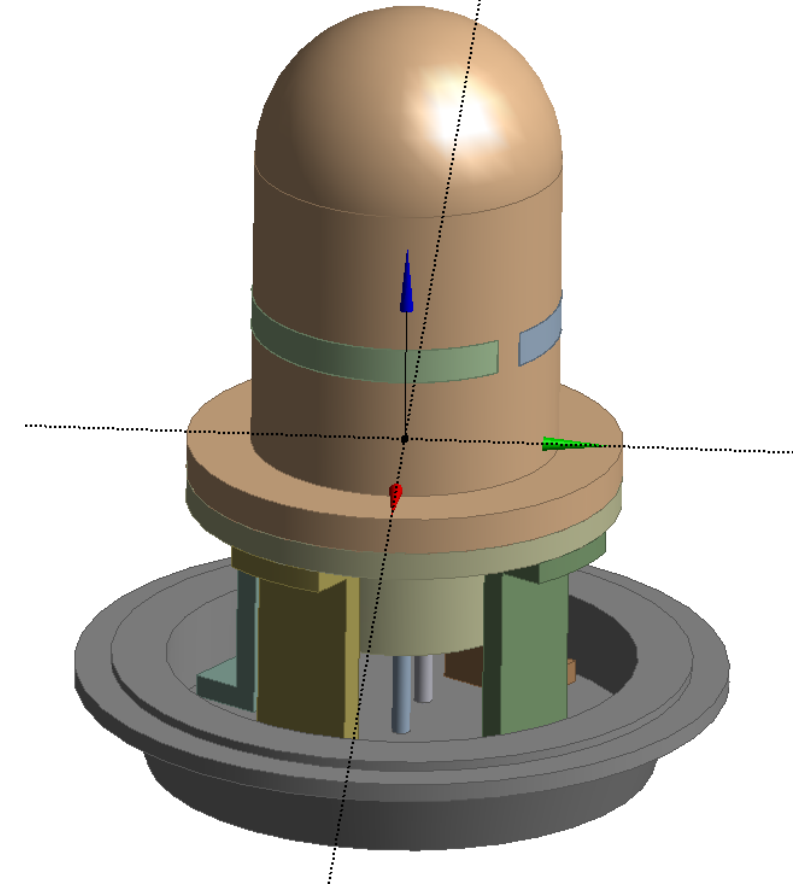

Non-Condensable Gas Selection

Transport Consideration: Diffusion Coefficient

$$D_{vg} = \frac{3}{16} \frac{\left(\frac{4\pi kT}{M_{vg}}\right)^{1/2}}{n\pi\sigma_{vg}^2\Omega_D} f_D = \frac{0.00266T^{3/2}}{PM_{vg}^{1/2}\sigma_{vg}^2\Omega_D}$$

	M _{NCG} (g/mol)	D _{vg} , m ² /s (307.15K)	D _{vg} , m ² /s (311.15K)
Neon & PnP	20.183	5.0*10 ⁻⁶	4.5*10 ⁻⁶
Xenon & PnP	131.293	1.3*10 ⁻⁶	1.2*10 ⁻⁶

Solubility Consideration: Henry's Law

- Henry's constants for Neon and Xenon in PnP were measured and proved to be very large.
- Based on this insolubility, Raoult's and Dalton's laws can be used to calculate the molar fraction of noncondensable gas in the ullage

$$P_{Total} = P_{PnP} + P_{NC}$$

$$P_{PnP} = y_{PnP} * P_{Total} = P_{PnP}^*$$

$$y_{NC} = 1 - \frac{P_{PnP}^*}{P_{Total}}$$

Neon & Xenon

- Diffuse similarly in PnP
- Provide least and most kinetics mass transfer resistance
- Can be degassed from the system

Non-condensable Gas Delivery System

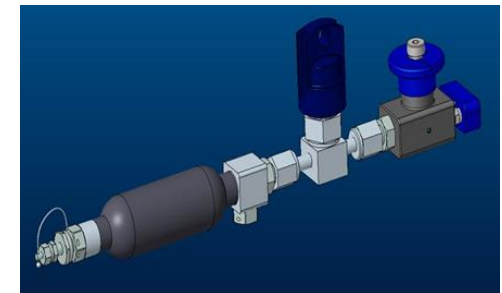
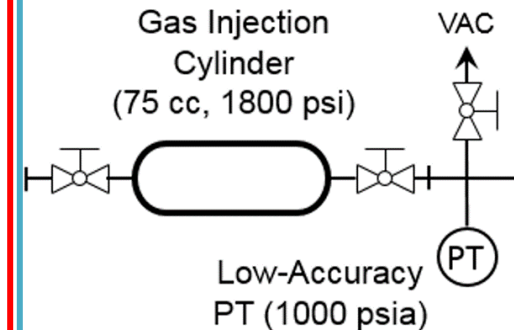

Kinetics Consideration: NC Mass Transfer Resistance

$\dot{m}_w / \text{NCG} / \dot{m}_{\text{pure vapor}}$

$$= \frac{\left[\left(\frac{\omega_{v\infty}\rho_{\infty, \text{total}}}{\rho_{\text{sat}}} - 0.579 \frac{(1 - \omega_{v\infty})\rho_{\infty, \text{total}}}{\rho_{\text{sat}}} \frac{M_g}{M_v} \right) \frac{T_{\infty}}{T_s} - 1 \right]}{\left[1 + 4.29 \left(\frac{(1 - \omega_{v\infty})\rho_{\infty, \text{total}}}{\rho_{\text{sat}}} \right)^{0.52} \left(\frac{M_g}{M_v} \right)^{0.74} \left(\frac{T_s}{T_{\infty}} \right)^{4.192} \right]^{-1}}$$

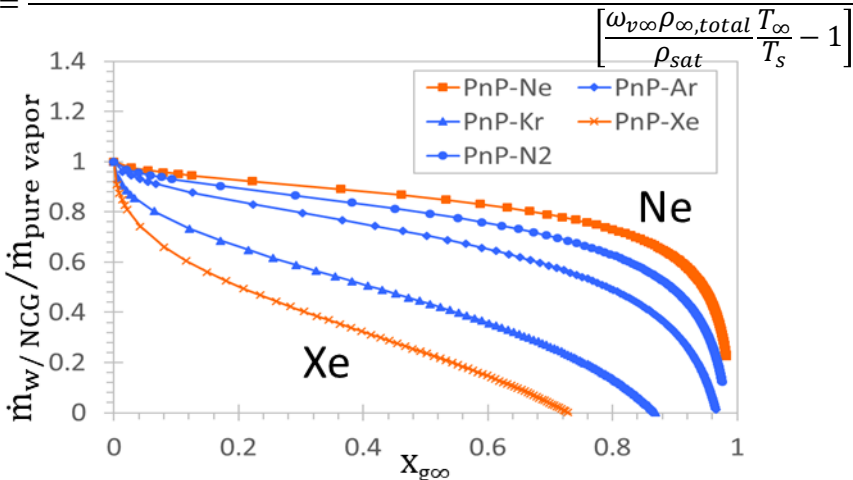

Pong and Moses (1986)

QDT Test: Hardware Diagram

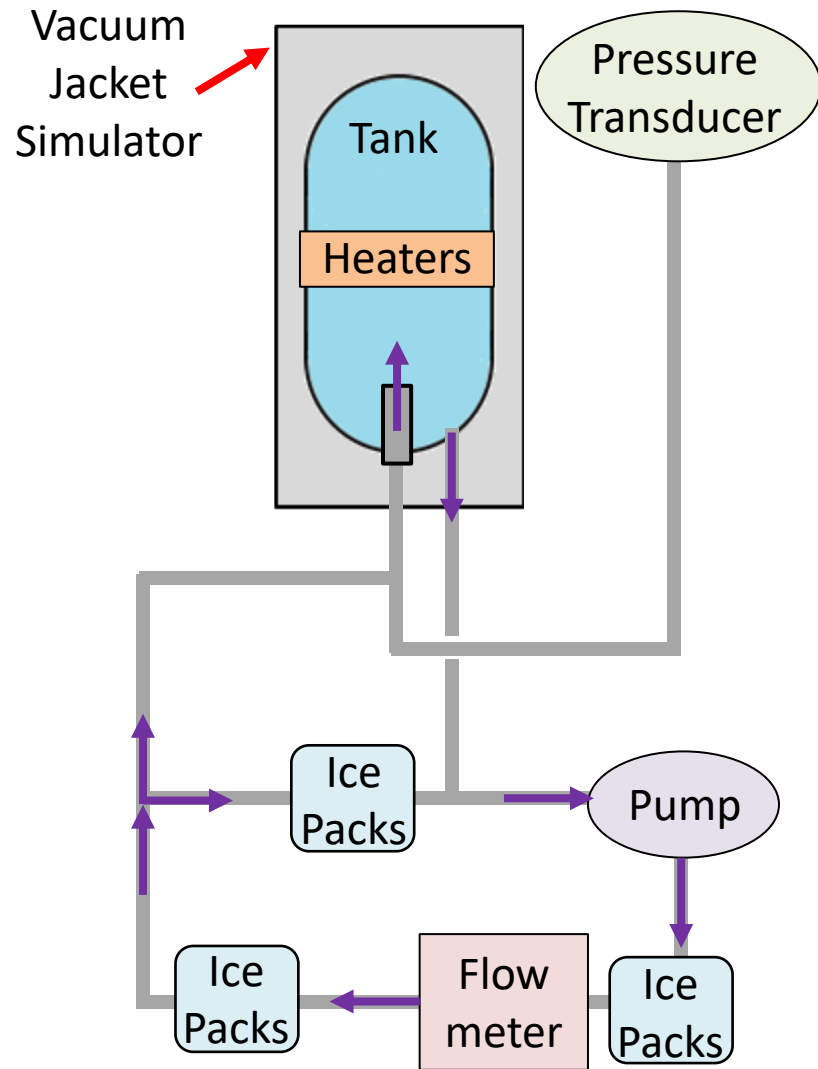

Self-pressurization followed by cold jet

- Tank heated via strip heaters
- Jet cooled using ice packs attached to the pipes

Vacuum Jacket Simulator

- Used to create a known temperature boundary
- Does not maintain a vacuum around the tank

RTDs:

- 4 on the tank
- 1 on the jacket
- 1 for air in the jacket
- 1 inlet
- 1 outlet
- 1 for room air

QDT data taken on a center plane in the tank

- Laser sheet excites the Quantum Dots
- Camera captures images

Test Matrix: 55% Fill Level pressurization, pressure control, and jet-ullage interaction tests



14 Self-Pressurization Tests

	Heating Mode	Duration (hours)	NCG	Mole Fraction
Vacuum Jacket	$T_{VJ} = T_{\text{tank}} + 2K$	4	Xenon	$x_g = 0$
				$x_g = 0.02$
				$x_g = 0.10$
				$x_g = 0.25$
Tank Heaters	0.2W	12	Xenon	$x_g = 0.25$
	0.4W	5		

Self-Press Tests to be followed by Jet tests ($T_{\text{jet}} = T_0 - 6^\circ\text{C}$ at 4 cm/s for 1 hour)

40 Subcooled Jet Tests from T_0

$T_{\text{Jet}} (^\circ\text{C})$	$v_{\text{Jet}} (\text{cm/s})$	Duration (hours)	NCG	Mole Fraction
$T_0 - 3$	2, 4, 10, 20	1	Xenon	$x_g = 0$
				$x_g = 0.02$
				$x_g = 0.05$
				$x_g = 0.25$
$T_0 - 6$	2, 4, 10, 20	1	Xenon	$x_g = 0$
				$x_g = 0.02$
				$x_g = 0.05$
				$x_g = 0.25$

8 Jet-Ullage Interaction Tests

Duration: 2 minutes

Only the first test starts at T_0

$T_{\text{Jet}} (^\circ\text{C})$	$v_{\text{Jet}} (\text{cm/s})$	NCG	Mole Fraction
$T_0 - 1$	2	Xenon	$x_g = 0$
$T_0 - 2$	4		$x_g = 0.25$
$T_0 - 3$	10		
$T_0 - 4$	20		

Test Matrix: 75% Fill Level pressurization, pressure control, and jet-ullage interaction tests



37 Self-Pressurization Tests

	Heating Mode	Duration (hours)
Vacuum Jacket	$T_{VJ} = T_{\text{tank}} + 2K$	4
Tank Heaters	0.2W	12
	0.4W	5

Self-Press Tests to be followed by Jet tests ($T_{\text{jet}} = T_0 - 6^\circ\text{C}$ at 4 cm/s for 1 hour)

NCG	Mole Fraction
Xenon	$x_g = 0$
	$x_g = 0.02$
	$x_g = 0.10$
	$x_g = 0.25$
Neon	$x_g = 0$
	$x_g = 0.02$
	$x_g = 0.10$
	$x_g = 0.25$

117 Subcooled Jet Tests from T_0

$T_{\text{Jet}} (^\circ\text{C})$	$v_{\text{Jet}} (\text{cm/s})$	Duration (hours)
$T_0 - 3$	2, 4, 10, 20	1
$T_0 - 6$	2, 4, 10, 20	1

NCG	Mole Fraction
Xenon	$x_g = 0$
	$x_g = 0.02$
	$x_g = 0.05$
	$x_g = 0.25$
Neon	$x_g = 0$
	$x_g = 0.02$
	$x_g = 0.05$
	$x_g = 0.25$

8 Jet-Ullage Interaction Tests

Duration: 2 minutes

Only the first test starts at T_0

$T_{\text{Jet}} (^\circ\text{C})$	$v_{\text{Jet}} (\text{cm/s})$	NCG	Mole Fraction
$T_0 - 1$	2	Xenon	$x_g = 0$
$T_0 - 2$	4		
$T_0 - 3$	10		
$T_0 - 4$	20		
			$x_g = 0.25$

Total Number of Tests: 392