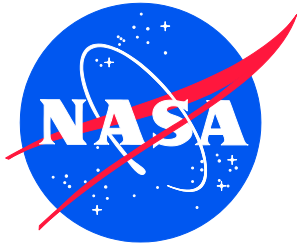


NASA/TM-20240011265  
NESC-RP-20-01525



# Trade Space Analyses: Balancing Crew and Mission Design Parameters

*Donna Dempsey*  
*Johnson Space Center, Houston, Texas*

*Robert Sargent*  
*Huntington Ingalls Industries, Newport News, Virginia*

*Alan Hobbs*  
*San Jose State University Foundation, San Jose, California*

*Kara Latorella*  
*Langley Research Center, Hampton, Virginia*

*Zhaofeng Huang*  
*The Aerospace Corporation, El Segundo, California*

*Christopher Niemann*  
*KBR Wyle Services, LLC, Houston, Texas*

*Andrew Chaikin*  
*Andrew Chaikin, LLC, Arlington, Vermont*

*Ruthan Lewis*  
*Goddard Space Flight Center, Greenbelt, Maryland*

*Peter Robinson, John Karasinski, Terence Tyson*  
*Ames Research Center, Mountain View, California*

*Thera Shear-Tungol, Marta Durham*  
*KBR Wyle Services, LLC, Houston, Texas*

*Amanda Lippert*  
*United States Navy, Arlington County, Virginia*

*Lauren Landon*  
*KBR Wyle Services, LLC, Houston, Texas*

*Sydney Hughs-Baird*  
*Georgia Institute of Technology, Atlanta, Georgia*

*Kyle Keyzer*  
*Rice University, Houston, Texas*

*Megan Dempsey*  
*University of Central Florida, Orlando, Florida*

*Jessica Maddox*  
*Purdue University, West Lafayette, Indiana*

*Spencer Pak*  
*University of California, Riverside, California*

*Cynthia Null/NESC*  
*Langley Research Center, Hampton, Virginia*

## NASA STI Program Report Series

Since its founding, NASA has been dedicated to the advancement of aeronautics and space science. The NASA scientific and technical information (STI) program plays a key part in helping NASA maintain this important role.

The NASA STI program operates under the auspices of the Agency Chief Information Officer. It collects, organizes, provides for archiving, and disseminates NASA's STI. The NASA STI program provides access to the NTRS Registered and its public interface, the NASA Technical Reports Server, thus providing one of the largest collections of aeronautical and space science STI in the world. Results are published in both non-NASA channels and by NASA in the NASA STI Report Series, which includes the following report types:

- **TECHNICAL PUBLICATION.** Reports of completed research or a major significant phase of research that present the results of NASA Programs and include extensive data or theoretical analysis. Includes compilations of significant scientific and technical data and information deemed to be of continuing reference value. NASA counterpart of peer-reviewed formal professional papers but has less stringent limitations on manuscript length and extent of graphic presentations.
- **TECHNICAL MEMORANDUM.** Scientific and technical findings that are preliminary or of specialized interest, e.g., quick release reports, working papers, and bibliographies that contain minimal annotation. Does not contain extensive analysis.
- **CONTRACTOR REPORT.** Scientific and technical findings by NASA-sponsored contractors and grantees.

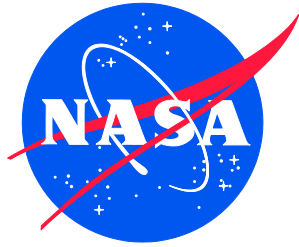
- **CONFERENCE PUBLICATION.** Collected papers from scientific and technical conferences, symposia, seminars, or other meetings sponsored or co-sponsored by NASA.
- **SPECIAL PUBLICATION.** Scientific, technical, or historical information from NASA programs, projects, and missions, often concerned with subjects having substantial public interest.
- **TECHNICAL TRANSLATION.** English-language translations of foreign scientific and technical material pertinent to NASA's mission.

Specialized services also include organizing and publishing research results, distributing specialized research announcements and feeds, providing information desk and personal search support, and enabling data exchange services.

For more information about the NASA STI program, see the following:

- Access the NASA STI program home page at <http://www.sti.nasa.gov>
- Help desk contact information: <https://www.sti.nasa.gov/sti-contact-form/> and select the "General" help request type.

NASA/TM-20240011265  
NESC-RP-20-01525



# Trade Space Analyses: Balancing Crew and Mission Design Parameters

*Donna Dempsey*  
*Johnson Space Center, Houston, Texas*

*Robert Sargent*  
*Huntington Ingalls Industries, Newport News, Virginia*

*Alan Hobbs*  
*San Jose State University Foundation, San Jose, California*

*Kara Latorella*  
*Langley Research Center, Hampton, Virginia*

*Zhaofeng Huang*  
*The Aerospace Corporation, El Segundo, California*

*Christopher Niemann*  
*KBR Wyle Services, LLC, Houston, Texas*

*Andrew Chaikin*  
*Andrew Chaikin, LLC, Arlington, Vermont*

*Ruthan Lewis*  
*Goddard Space Flight Center, Greenbelt, Maryland*

*Peter Robinson, John Karasinski, Terence Tyson*  
*Ames Research Center, Mountain View, California*

*Thera Shear-Tungol, Marta Durham*  
*KBR Wyle Services, LLC, Houston, Texas*

*Amanda Lippert*  
*United States Navy, Arlington County, Virginia*

*Lauren Landon*  
*KBR Wyle Services, LLC, Houston, Texas*

*Sydney Hughs-Baird*  
*Georgia Institute of Technology, Atlanta, Georgia*

*Kyle Keyzer*  
*Rice University, Houston, Texas*

*Megan Dempsey*  
*University of Central Florida, Orlando, Florida*

*Jessica Maddox*  
*Purdue University, West Lafayette, Indiana*

*Spencer Pak*  
*University of California, Riverside, California*

*Cynthia Null/NESC*  
*Langley Research Center, Hampton, Virginia*

## Acknowledgments

The assessment team is grateful to FOD and the Human Health and Performance Directorate (HH&PD) for providing invaluable subject matter expert (SME) support from crew, flight controllers, flight surgeons, and instructors who supported interviews and discussions critical to the outcome of this assessment. The assessment team would like to thank Paul Dum and Jason Campbell for supporting coordination of EVA and robotics flight following data collection and Bill Dwyer for his work in coordinating support from contractor SMEs across FOD.

The assessment team appreciates the time and expertise of each person interviewed for the historical narrative: George Abbey, Kathy Bol, Yvonne Clearwater, Marc Cohen, John Connolly, Doug Cooke, Dan Dumbacher, Kyle Fairchild, Jim Geffre, Tony Griffith, Steve Hoffman, Ruthan Lewis, Mark Lupisella, Wendell Mendell, Chris Niemann, David Portree, Brent Sherwood, Jack Stuster, and Larry Toups.

The assessment team would like to thank the Mars Architecture Team, the Lunar Architecture Team, the Habitability Team, and the Mars Campaign Office personnel who reviewed the Mars master task list and would like to thank Ian Maddox for organizing and conducting the master task list review.

The assessment team would like to thank the following peer reviewers for their time and valuable input: Morgan Abney, Tandi Bagian, Steven Gentz, John Hanson, Jon Haas, Jon Holladay, Robert Johnson, Binaifer Kadwa, Ginger Kerrick, Heather Koehler, Lore Prokop, James Schier, Mark Sonoda, and Azita Valinia.

<p>The use of trademarks or names of manufacturers in the report is for accurate reporting and does not constitute an official endorsement, either expressed or implied, of such products or manufacturers by the National Aeronautics and Space Administration.</p>
--

Available from:

NASA STI Program / Mail Stop 050  
NASA Langley Research Center  
Hampton, VA 23681-2199





# **NASA Engineering and Safety Center Technical Assessment Report**

## **Trade Space Analyses: Balancing Crew and Mission Design Parameters**

**TI-20-01525**

**June 25, 2024**

## Report Approval and Revision History

NOTE: This document was approved at the June 25, 2024, NRB.

Approved: _____
NESC Director
Date

Version	Description of Revision	Office of Primary Responsibility	Effective Date
1.0	Initial Release	Dr. Cynthia H. Null, NASA Technical Fellow for Human Factors, ARC	6/25/2024

# Table of Contents

## Technical Assessment Report

<b>1.0</b>	<b>Notification and Authorization</b> .....	<b>10</b>
<b>2.0</b>	<b>Signature Page</b> .....	<b>11</b>
<b>3.0</b>	<b>Team List</b> .....	<b>12</b>
3.1	Acknowledgements.....	12
<b>4.0</b>	<b>Executive Summary</b> .....	<b>14</b>
<b>5.0</b>	<b>Assessment Plan</b> .....	<b>22</b>
<b>6.0</b>	<b>Problem Description, Background, and Proposed Solution</b> .....	<b>23</b>
6.1	Problem Description.....	23
6.2	Background.....	27
6.2.1	Humans to Mars, But How Many? A Historical Review of Crew Size Determinations for Mars Missions.....	27
6.2.2	Crew Size Determination within the DoD.....	44
6.2.3	Background Summary.....	48
6.3	Proposed Solution.....	49
6.3.1	Gather Mars Mission Information.....	50
6.3.2	Determine Use Cases to Model.....	54
6.3.3	Create a Trade Space Evaluation Framework.....	58
6.3.4	Conduct Human Performance Modeling.....	63
6.3.5	Perform Trade Space Analysis.....	64
6.3.6	Summary of Proposed Solution.....	64
<b>7.0</b>	<b>Human Performance Modeling and Trade Space Analysis</b> .....	<b>65</b>
7.1	Listing of the Models.....	65
7.2	Modeling and Analysis.....	66
7.2.1	Human Performance Modeling Introduction.....	66
7.2.2	IV Operations for Planetary Surface EVA Model.....	71
7.2.2.1	Purpose and Scope.....	71
7.2.2.2	Method and Procedures.....	73
7.2.2.3	Assumptions and Model Limitations.....	75
7.2.2.4	Results and Discussion.....	76
7.2.2.5	Conclusions.....	124
7.2.3	Robotic Arm Assisted EVA Operator Model.....	127
7.2.3.1	Purpose and Scope.....	127
7.2.3.2	Methods and Procedures.....	132
7.2.3.3	Assumptions and Model Limitations.....	145
7.2.3.4	Results and Discussion.....	148
7.2.3.5	Conclusions.....	188
7.2.4	Mars Transit Crew Model.....	189
7.2.4.1	Purpose and Scope.....	189
7.2.4.2	Methods and Procedures.....	189
7.2.4.3	Assumptions and Model Limitations.....	220
7.2.4.4	Results and Discussion.....	222
7.2.4.5	Conclusions.....	234
7.2.5	Personnel, Expertise, and Training Model.....	235
7.2.5.1	Purpose and Scope.....	235
7.2.5.2	Methods and Procedures.....	240
7.2.5.3	Assumptions and Model Limitations.....	262
7.2.5.4	Results and Discussion.....	263
7.2.5.5	Conclusions.....	271

7.3	Team and Behavioral Health Considerations .....	272
7.4	Summary of Trade Space Analysis and Methodology.....	274
<b>8.0</b>	<b>Findings and NESC Recommendations .....</b>	<b>276</b>
8.1	Findings .....	276
8.2	NESC Recommendations .....	278
<b>9.0</b>	<b>Alternate Technical Opinion(s) .....</b>	<b>279</b>
<b>10.0</b>	<b>Other Deliverables .....</b>	<b>279</b>
<b>11.0</b>	<b>Recommendations for the NASA Lessons Learned Database .....</b>	<b>282</b>
<b>12.0</b>	<b>Recommendations for NASA Standards, Specifications, Handbooks, and Procedures .....</b>	<b>282</b>
<b>13.0</b>	<b>Definition of Terms.....</b>	<b>282</b>
<b>14.0</b>	<b>Acronyms and Nomenclature List.....</b>	<b>283</b>
<b>15.0</b>	<b>References.....</b>	<b>286</b>

## List of Figures

Figure 1.	International Space Station (ISS) Ground Personnel .....	14
Figure 2.	High-priority ISS IFIs .....	26
Figure 3.	Notional Crew Size, Risk, and Cost Curves.....	27
Figure 4.	Littoral Combat Ship.....	48
Figure 5.	Proposed Solution .....	49
Figure 6.	Architecting From the Right .....	50
Figure 7.	Communication Infrastructure .....	52
Figure 8.	Earth-Sun-Mars Conjunction .....	53
Figure 9.	Crew Response to Off-Nominal Conditions .....	55
Figure 10.	Tradespace Dimensions for Evaluating Crewing Configurations .....	59
Figure 11.	Trade Space Framework for Evaluating Crew Sizes.....	63
Figure 12.	Mars Crew Size Decision Process.....	65
Figure 13.	Workload Resources in IMPRINT .....	67
Figure 14.	Task Performance versus Mental Workload .....	68
Figure 15.	The Bedford Workload Scale.....	70
Figure 16.	MCC Positions .....	73
Figure 17.	Flight Director Nominal Tasks.....	79
Figure 18.	Flight Director Communication Tasks.....	80
Figure 19.	Flight Director Off-nominal Tasks.....	80
Figure 20.	Flight Director Workload with No Complex Off-nominal Events.....	81
Figure 21.	Flight Director Workload with One Complex Off-nominal Events.....	82
Figure 22.	Ground IV Nominal Tasks .....	85
Figure 23.	Ground IV Communication Tasks .....	86
Figure 24.	Ground IV Off-nominal Tasks .....	86
Figure 25.	Ground IV Workload with no Complex Off-nominal Events.....	87
Figure 26.	Ground IV Workload with One Complex Off-nominal Event.....	88
Figure 27.	EVA Flight Controller Nominal Tasks .....	92
Figure 28.	EVA Flight Controller Communication Tasks.....	92
Figure 29.	EVA Flight Controller Off-nominal Tasks .....	92
Figure 30.	EVA Position Workload with no Complex Off-nominal Events.....	93
Figure 31.	EVA Position Workload with One Complex Off-nominal Event.....	94
Figure 32.	EVA Task Flight Controller Nominal Tasks.....	98
Figure 33.	EVA Task Flight Controller Communication Tasks.....	98
Figure 34.	EVA Task Flight Controller Off-nominal Tasks.....	98
Figure 35.	EVA Task Position Workload with no Complex Off-nominal Events .....	99

Figure 36.	EVA Task Position Workload with One Complex Off-nominal Event .....	100
Figure 37.	EMU Flight Controller Nominal Tasks.....	103
Figure 38.	EMU Flight Controller Communication Tasks.....	104
Figure 39.	EMU Flight Controller Off-nominal Tasks.....	104
Figure 40.	EMU Position Workload with no Complex Off-nominal Events .....	105
Figure 41.	EMU Position Workload with one Complex Off-nominal Event .....	106
Figure 42.	Nominal Tasks for Hypothetical Combined Flight Director/IV Position .....	109
Figure 43.	Communication Tasks for Hypothetical Combined Flight Director/IV Position.....	110
Figure 44.	Off-nominal Tasks for Hypothetical Combined Flight Director/IV Position .....	110
Figure 45.	Workload for a Combined Flight Director/IV Position with no Complex Off-Nominal Events.....	111
Figure 46.	Workload for a Combined Flight Director/IV Position with one Complex Off-Nominal Events.....	112
Figure 47.	Comparison of Workload for Hypothetical Combined Flight Director/IV Position with Current Flight Director and Ground IV Workload for EVAs with No Complex Off-nominal Events.....	113
Figure 48.	Comparison of Workload for Hypothetical Combined Flight Director/IV Position with Current Flight Director and Ground IV Workload for EVAs with One Complex Off-nominal Event .....	114
Figure 49.	Nominal Tasks for Hypothetical Combined EVA, EVA TASK, and EMU Position .....	116
Figure 50.	Communication Tasks for Hypothetical Combined EVA, EVA TASK, and EMU Position.....	117
Figure 51.	Off-nominal Tasks for Hypothetical Combined EVA, EVA TASK, and EMU Position.....	117
Figure 52.	Workload for Combined EVA, EVA Task, and EMU Position with no Off-nominal Events.....	118
Figure 53.	Workload for Combined EVA, EVA Task, and EMU Position with one Off-nominal Event .....	119
Figure 54.	Comparison of Workload for Individual and Combined EVA, EVA Task, and EMU Positions with no Complex Off-nominal Events.....	120
Figure 55.	Comparison of Workload for Individual and Combined EVA, EVA Task, and EMU Positions with one Complex Off-nominal Event .....	121
Figure 56.	a. Robotic Workstation and Ancillary Controls and Displays; b. Robotic Workstation On Orbit in ISS .....	130
Figure 57.	The SSRMS on Orbit .....	131
Figure 58.	Automations defined in the IMPRINT Analysis Tree .....	136
Figure 59.	Highest Level IMPRINT Task Network.....	136
Figure 60.	Robotic Arm Control Segment Task Network.....	137
Figure 61.	Pre-movement Tasks .....	137
Figure 62.	Post-movement Tasks .....	138
Figure 63.	Manual Robotic Arm Movement Task Network.....	139
Figure 64.	Auto Robotic Arm Movement Task Network.....	140
Figure 65.	Respond to Auto Failure Task Network.....	141
Figure 66.	Robotic Arm Control Automation Settings.....	141
Figure 67.	Robotic Arm Control Automation Settings.....	142
Figure 68.	Peak Workload for Every Model Run.....	149
Figure 69.	Time-Averaged Workload for Every Model Run .....	149
Figure 70.	Percent Time in Overload for Every Model Run .....	150
Figure 71.	Mean Mission Time per Model Run Sets.....	150
Figure 72.	Maximum Mission Time per Model Run Sets .....	151
Figure 73.	Minimum Mission Time per Model Run Sets.....	151

Figure 74.	Total Robotic Arm Movement Time per Model Run Sets.....	152
Figure 75.	Workload Over Time for Baseline GCA Run 01.....	153
Figure 76.	Workload Over Time for Baseline JOCAS Run 02.....	154
Figure 77.	Workload Metric Comparison Analysis 1.....	155
Figure 78.	Mission Time Comparison Analysis 1.....	156
Figure 79.	Workload Over Time for Fatigued GCA Run 03.....	157
Figure 80.	Workload Over Time for Fatigued JOCAS Run 04.....	158
Figure 81.	Workload Metric Comparison Analysis 2.....	159
Figure 82.	Mission Time Comparison Analysis 2.....	160
Figure 83.	Workload Over Time for JOCAS with Scripted Failure Run 05.....	161
Figure 84.	Workload Metric Comparison Analysis 3.....	162
Figure 85.	Mission Time Comparison Analysis 3.....	163
Figure 86.	Workload Over Time for JOCAS with Fail Expected No Salience Run 06.....	164
Figure 87.	Workload Over Time for JOCAS with Fail Expected High Salience Run 07.....	164
Figure 88.	Workload Over Time for JOCAS with Fail Unexpected No Salience Run 08.....	165
Figure 89.	Workload Over Time for JOCAS with Fail Unexpected High Salience Run 09.....	165
Figure 90.	Workload Metric Comparison Analysis 4.....	168
Figure 91.	Mission Time Comparison Analysis 4.....	169
Figure 92.	Workload for JOCAS with Fail Unexpected No Salience and Fatigue Run 10.....	170
Figure 93.	Workload Metric Comparison Analysis 5.....	171
Figure 94.	Mission Time Comparison Analysis 5.....	172
Figure 95.	Workload Over Time for GCA with Hard ECLSS Run 11.....	173
Figure 96.	Workload Over Time for JOCAS with Hard ECLSS Run 12.....	173
Figure 97.	Workload Metric Comparison Analysis 6.....	175
Figure 98.	Mission Time Comparison Analysis 6.....	176
Figure 99.	Workload Over Time for GCA with M1 and M2 Run 13.....	177
Figure 100.	Workload Over Time for JOCAS with M1 and M2 Run 14.....	177
Figure 101.	Workload Metric Comparison Analysis 7.....	179
Figure 102.	Mission Time Comparison Analysis 7.....	180
Figure 103.	Workload Over Time for GCA with Workload Management Run 15.....	181
Figure 104.	Workload Metric Comparison Analysis 8.....	182
Figure 105.	Mission Time Comparison Analysis 8.....	183
Figure 106.	Crewing Configuration Tradespace Analysis.....	184
Figure 107.	Subjective Workload Ratings.....	184
Figure 108.	MAT Composition of the Nominal Work Week (Mars Surface).....	191
Figure 109.	NESC Composition of the Nominal Work Week (Mars Transit).....	192
Figure 110.	Thursday Schedule for Four Crew.....	193
Figure 111.	Example Snippet of a Regular Mars Transit Crew Schedule.....	194
Figure 112.	IMPRINT Analysis Tree Showing Different Force Models.....	196
Figure 113.	IMPRINT Unplanned Event Interfaces.....	197
Figure 114.	IMM Data Bucket Analysis Result.....	199
Figure 115.	Justification of Using Poisson Distribution for Medical Event Rate (Crew 4 data).....	200
Figure 116.	Justification of Using Poisson Distribution for Medical Event Rate (Crew 12 data).....	200
Figure 117.	Log-Normal Fitting for Crew 4 Total Quality Time Loss.....	201
Figure 118.	Log-Normal Fitting for Crew 12 Total Quality Time Loss.....	201
Figure 119.	ISS ECW Data Sheet.....	205
Figure 120.	Number of Days that ISS had at least One Caution Event.....	206
Figure 121.	Number of Days that ISS had at least one Warning Event.....	207
Figure 122.	Number of Days that ISS had at least one Emergency Event.....	207
Figure 123.	ISS Vehicle Advisory Data Sheet.....	208
Figure 124.	Number of Days that ISS had at least 1 Advisory for CDS.....	210

Figure 125.	Number of Days that ISS had at least 1 Advisory for CNT .....	210
Figure 126.	Number of Days that ISS had at least 1 Advisory for ECL .....	210
Figure 127.	Number of Days that ISS had at least 1 Advisory for EPS .....	211
Figure 128.	Number of Days that ISS had at least 1 Advisory for MCS .....	211
Figure 129.	Number of Days that ISS had at least One Advisory for TCS .....	211
Figure 130.	Cumulative Distribution Function for Total Corrective Maintenance Crew Time .....	214
Figure 131.	ISS Hight Priority IFIs and Vehicle System IFIs .....	215
Figure 132.	Crew Activity Report from IMPRINT .....	223
Figure 133.	Average Crew Hours - Perfect World ISS Scenario .....	224
Figure 134.	Average Crew Hours - Adjusted ISS Scenario compared to Perfect World ISS Scenario.....	225
Figure 135.	Percentage of Work Hour Decrements for Added Mars Scenario Tasks.....	227
Figure 136.	Average Crew Hours - Adjusted ISS Scenario compared to Mars Transit with Average Unplanned Events .....	229
Figure 137.	Average Crew Hours - Adjusted ISS Scenario compared to Mars Transit with 75 Percentile Unplanned Events .....	230
Figure 138.	Grouped Tasking for Additional Analysis .....	231
Figure 139.	Comparison of Grouped Crew Average Hours for Different Scenarios .....	232
Figure 140.	Average Crew Work Hours for Different Scenarios .....	232
Figure 141.	High Priority ISS Items for Investigation .....	236
Figure 142.	HSRB Risk Matrix .....	239
Figure 143.	Knowledge Retention Issues in ISS Crew Pre-mission Training.....	258
Figure 144.	Optimization of Assignments.....	262
Figure 145.	Training Hours for a Four-Person Crew .....	266
Figure 146.	Training Hours for a Twelve-Person Crew .....	270

## List of Tables

Table 1.	Nominal Tasks for Flight Director Position during ISS EVA.....	78
Table 2.	Off-Nominal Tasks for Flight Director .....	79
Table 3.	Flight Director Workload Metrics for 2.5-hour Period of an ISS EVA .....	82
Table 4.	Nominal Tasks for Ground IV Position .....	84
Table 5.	Off-Nominal Tasks for Ground IV Position .....	85
Table 6.	Ground IV Position Workload Metrics for 2.5-hour Period of an ISS EVA .....	88
Table 7.	Nominal Tasks for EVA Position .....	90
Table 8.	Off-Nominal Tasks for EVA Position.....	91
Table 9.	EVA Position Workload Metrics for 2.5-hour Period of an ISS EVA.....	94
Table 10.	Nominal Tasks for EVA Task Position.....	96
Table 11.	Off-Nominal Tasks for EVA Task Position.....	97
Table 12.	EVA Task Position Workload Metrics for 2.5-hour Period of an ISS EVA.....	100
Table 13.	Nominal Tasks for EMU Position.....	102
Table 14.	Off-Nominal Tasks for EMU Position.....	103
Table 15.	EMU Position Workload Metrics for 2.5-hour period of an ISS EVA .....	106
Table 16.	Nominal Tasks for Hypothetical Combined Flight Director/IV Position .....	107
Table 17.	Off-Nominal Tasks for Hypothetical Combined Flight Director/IV Position.....	109
Table 18.	Combined Flight Director/IV Position Workload Metrics for 2.5-hour Period of a Hypothetical Mars EVA.....	112
Table 19.	Combined EVA, EVA Task, and EMU Positions.....	114
Table 20.	Off-Nominal Tasks for Hypothetical Combined EVA, EVA Task and EMU Position.....	116

Table 21.	Combined EVA, EVA Task, and EMU Position Workload Metrics for 2.5-hour Period of a Hypothetical Mars EVA .....	119
Table 22.	Guide for Discussion on Feasibility of Combined Positions for a Future Mars Planetary Surface EVA .....	123
Table 23.	HARI Model Runs Summarized by Variables Changed.....	143
Table 24.	HARI Model Comparative Analyses Summarized .....	144
Table 25.	Tasks Concurrently Performed at Peak Workload Values Run 01 .....	154
Table 26.	Tasks Concurrently Performed at Peak Workload Values Run 02 .....	155
Table 27.	Workload Metric Comparison Analysis 1.....	155
Table 28.	Mission Time Comparison Analysis 1.....	156
Table 29.	Tasks Concurrently Performed at Peak Workload Values Run 03 .....	158
Table 30.	Tasks Concurrently Performed at Peak Workload Values Run 04 .....	159
Table 31.	Workload Metric Comparison Analysis 2.....	159
Table 32.	Mission Time Comparison Analysis 2.....	160
Table 33.	Tasks Concurrently Performed at Peak Workload Values Run 05 .....	161
Table 34.	Workload Metric Comparison Analysis 3.....	162
Table 35.	Mission Time Comparison Analysis 3.....	163
Table 36.	Tasks Concurrently Performed at Peak Workload Values Run 06 .....	166
Table 37.	Tasks Concurrently Performed at Peak Workload Values Run 07 .....	166
Table 38.	Tasks Concurrently Performed at Peak Workload Values Run 08 .....	166
Table 39.	Tasks Concurrently Performed at Peak Workload Values Run 09 .....	167
Table 40.	Workload Metric Comparison Analysis 4.....	167
Table 41.	Mission Time Comparison Analysis 4.....	168
Table 42.	Tasks Concurrently Performed at Peak Workload Values Run 10 .....	170
Table 43.	Workload Metric Comparison Analysis 5.....	171
Table 44.	Mission Time Comparison Analysis 5.....	171
Table 45.	Tasks Concurrently Performed at Peak Workload values Run 11 .....	174
Table 46.	Tasks Concurrently Performed at Peak Workload Values Run 12 .....	174
Table 47.	Workload Metric Comparison Analysis 6.....	174
Table 48.	Mission Time Comparison Analysis 6.....	175
Table 49.	Tasks Concurrently Performed at Peak Workload Values Run 13 .....	178
Table 50.	Tasks Concurrently Performed at Peak Workload Values Run 14 .....	178
Table 51.	Workload Metric Comparison Analysis 7.....	178
Table 52.	Mission Time Comparison Analysis 7.....	179
Table 53.	Workload Metric Comparison Analysis 8.....	181
Table 54.	Mission Time Comparison Analysis 8.....	182
Table 55.	100 Medical Conditions in IMM.....	198
Table 56.	IMM Event Statistics List with Sample Data Values*.....	198
Table 57.	IMM Medical Event Bucket Result for Crew 4 .....	202
Table 58.	IMM Medical Event Bucket Result for Crew 5 .....	203
Table 59.	IMM Medical Event Bucket Result for Crew 6 .....	203
Table 60.	IMM Medical Event Bucket Result for Crew 7 .....	203
Table 61.	IMM Medical Event Bucket Result for Crew 8 .....	204
Table 62.	IMM Medical Event Bucket Result for Crew 9 .....	204
Table 63.	IMM Medical Event Bucket Result for Crew 10 .....	204
Table 64.	IMM Medical Event Bucket Result for Crew 11 .....	204
Table 65.	IMM Medical Event Bucket Result for Crew 12 .....	205
Table 66.	ECW Rates and Crew Time Off*.....	208
Table 67.	Vehicle Advisory Event Rates for Each System and Crew Time Off *.....	212
Table 68.	Vehicle Corrected Maintenance Rate and Crew Time Involved.....	213
Table 69.	Predicted Maintenance Task Rates and Crew Times for Mars 270-day Transit Mission..	214



Table 70.	ISS Vehicle IFI Rate Per Year (from 2001 to 2019).....	217
Table 71.	Mars Transit Mission IFI Rate .....	217
Table 72.	Predicted Mars Transit Mission .....	218
Table 73.	MCC Tasks Shifted to Mars Crew .....	220
Table 74.	IMPRINT Activity Priority Table .....	221
Table 75.	Post Processing “Give Back” to Some Activities .....	222
Table 76.	Average Crew Work Hours.....	233
Table 77.	Extra Work Capacity for Additional Crewmembers .....	233
Table 78.	Crewed Mars Mission Phase Durations Right .....	237
Table 79.	Occurrence Rate for Unforeseen Failures .....	237
Table 80.	Likelihood of Loss of Crew/Loss of Mission Outcomes .....	239
Table 81.	Crew Qualifications for Missions to Mars .....	242
Table 82.	The Generic Mars CQRM – MPCV.....	251
Table 83.	The Generic Mars CQRM – Transit Habitat.....	252
Table 84.	The Generic Mars CQRM – Mars Descent Vehicle (MDV).....	253
Table 85.	The Generic Mars CQRM – Mars Rover .....	254
Table 86.	The Generic Mars – Mars Ascent Vehicle (MAV) .....	255
Table 87.	Piloting, EVA, and System Leads.....	259
Table 88.	Mars CQRM Overview for Four Crew .....	265
Table 89.	CQRM Overview for Twelve Crew .....	269
Table 90.	Simulator Software Classification Applicability to IMPRINT Simulations .....	280
Table 91.	Models and Simulation (M&S) Credibility Assessment.....	281

# Technical Assessment Report

## 1.0 Notification and Authorization

In 2020, the Associate Administrator for Human Exploration and Operations and the Agency's Federated Board requested an assessment to develop a methodology for trade space analysis comparing crew size for Mars missions against mission design parameters. The NASA Engineering and Safety Center (NESC) conducted an assessment to develop a methodology for systematic, repeatable trade space analysis for crew size and developed an initial set of human performance models and a list of candidate crew tasks for NASA's first mission to Mars.

The key stakeholders for this assessment included:

- Ms. Cathy Koerner, Associate Administrator of the Exploration Systems Development Mission Directorate (ESDMD), NASA Headquarters
  - Mr. Amit Kshatriya, Deputy Associate Administrator for the Moon to Mars Program, NASA Headquarters
  - Ms. Danye Ise, Director of the Mars Campaign Office (MCO), NASA Headquarters
  - Ms. Nujoud Merancy, Deputy Associate Administrator for the Strategy and Architecture Office (SAO), NASA Headquarters
  - Ms. Michelle Rucker, Lead of the Mars Architecture Team (MAT), JSC
- Mr. Kenneth Bowersox, Associate Administrator of the Space Operations Mission Directorate (SOMD), NASA Headquarters
- Dr. Kurt Vogel, Associate Administrator for the Space Technology Mission Directorate (STMD), NASA Headquarters
- Dr. J. D. Polk, Chief Health and Medical Officer, NASA Headquarters
  - Ms. Mary Van Baalen, Chair of the Human System Risk Board (HSRB), JSC
  - Mr. David Baumann, Director of the Human Research Program (HRP), JSC
  - Dr. Alonso Vera, Risk Custodian for the Human System Integration Architecture (HSIA), ARC
- Space Flight Operations
  - Mr. Norman Knight, Director of the Flight Operations Directorate (FOD), JSC
  - Mr. Joseph Acaba, Chief of the Astronaut Office, JSC
- NESC

## 2.0 Signature Page

Submitted by:

---

Dr. Cynthia H. Null

Significant Contributors:

---

Dr. Donna L. Dempsey

---

Mr. Robert Sargent

---

Dr. Alan Hobbs

---

Dr. Kara A. Latorella

---

Dr. Zhaofeng C. Huang

---

Mr. Christopher Niemann

---

Mr. Andy Chaikin

---

Mr. Ruthan Lewis

Signatories declare the findings, observations, and NESC recommendations compiled in the report are factually based from data extracted from program/project documents, contractor reports, and open literature, and/or generated from independently conducted tests, analyses, and inspections.

### 3.0 Team List

Name	Discipline	Organization
<b>Core Team</b>		
Dr. Cynthia Null	NESC Lead	LaRC
Dr. Donna Dempsey	Technical Lead	JSC
Dr. Alan Hobbs	Human Factors	ARC/ San Jose State University Foundation (SJSU)
Dr. Kara Latorella	Human Factors	LaRC
Dr. Ruthan Lewis	Human Factors	GSFC
LCDR Amanda Lippert	Human Factors	United States Navy (USN)
John Karasinski	Human Factors	ARC
Robert Sargent	Human Factors	Huntington Ingalls Industries
Terence Tyson	Human Factors	ARC
Peter Robinson	Intelligent Systems	ARC
Dr. Zhaofeng Huang	Reliability and Statistics	The Aerospace Corporation
Marta Durham	Space Flight Operations	JSC/KBR Wyle Services, LLC
Christopher Niemann	Space Flight Operations	JSC/KBR Wyle Services, LLC
Thera Shear-Tungol	Space Flight Operations	JSC/KBR Wyle Services, LLC
Andrew Chaikin	Space Historian and Author	Andrew Chaikin, LLC
<b>Student Interns</b>		
Megan Dempsey	Student Intern	University of Central Florida
Sydney Hughs-Baird	Student Intern	Georgia Institute of Technology
Kyle Keyzer	Student Intern	Rice University
Jessica Maddox	Student Intern	Purdue University
Spencer Pak	Student Intern	University of California, Riverside
<b>Consultants</b>		
Lauren Landon	Industrial Organizational Psychology	JSC/KBR Wyle Services, LLC
<b>Business Management</b>		
Austin DeLaHunt	Program Analyst	LaRC/MTSO
Becki Hendricks	Program Analyst	LaRC/MTSO
<b>Assessment Support</b>		
Missy Strickland	Project Coordinator	LaRC/AMA
Linda Burgess	Planning and Control Analyst	LaRC/AMA
Erin Moran	Technical Editor	LaRC/AMA
Jonay Campbell	Technical Editor	LaRC/AS&M

### 3.1 Acknowledgements

The assessment team is grateful to FOD and the Human Health and Performance Directorate (HH&PD) for providing invaluable subject matter expert (SME) support from crew, flight controllers, flight surgeons, and instructors who supported interviews and discussions critical to the outcome of this assessment. The assessment team would like to thank Paul Dum and Jason Campbell for supporting coordination of EVA and robotics flight following data collection and Bill Dwyer for his work in coordinating support from contractor SMEs across FOD.

The assessment team appreciates the time and expertise of each person interviewed for the historical narrative: George Abbey, Kathy Bol, Yvonne Clearwater, Marc Cohen, John Connolly,

Doug Cooke, Dan Dumbacher, Kyle Fairchild, Jim Geffre, Tony Griffith, Steve Hoffman, Ruthan Lewis, Mark Lupisella, Wendell Mendell, Chris Niemann, David Portree, Brent Sherwood, Jack Stuster, and Larry Toups.

The assessment team would like to thank the Mars Architecture Team, the Lunar Architecture Team, the Habitability Team, and the Mars Campaign Office personnel who reviewed the Mars master task list and would like to thank Ian Maddox for organizing and conducting the master task list review.

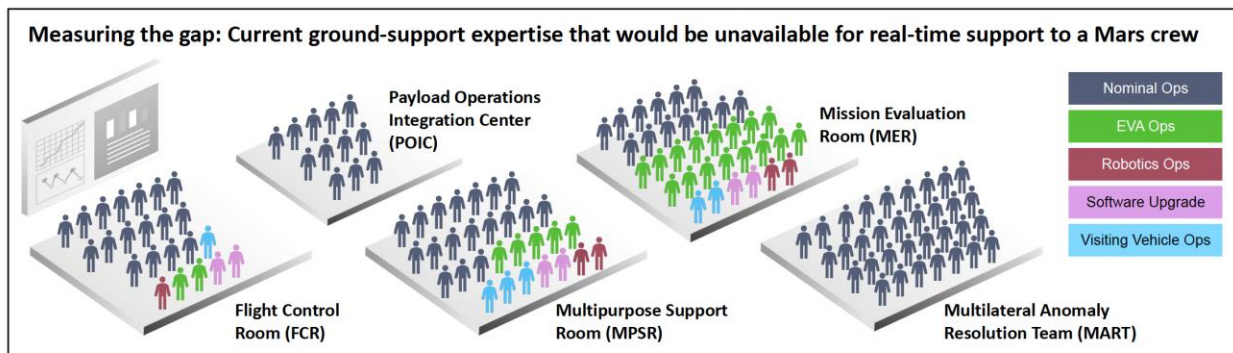
The assessment team would like to thank the following peer reviewers for their time and valuable input: Morgan Abney, Tandi Bagian, Steven Gentz, John Hanson, Jon Haas, Jon Holladay, Robert Johnson, Binaifer Kadwa, Ginger Kerrick, Heather Koehler, Lore Prokop, James Schier, Mark Sonoda, and Azita Valinia.

## 4.0 Executive Summary

The NASA Engineering and Safety Center (NESC) has developed, for the first time, a systematic and quantitative methodology to aid determination of crew sizes for human Mars missions. This capability, and its associated suite of modeling tools, will enable the development of an evidence-based trade space to guide crew size decision-making.

This capability was developed out of a recognition that a Mars crew will be denied real-time support from the Mission Control Center (MCC), owing to the distance-induced communication delay (up to ~22 minutes one-way) and one continuous blackout period with Earth during superior conjunction (up to ~3 weeks each mission). This fundamental constraint, which is unprecedented in the history of human spaceflight, brings a new appreciation for what the term “crew” encompasses. In every previous NASA program, the flight crew has relied on the combined intellects and energies of experts in the Flight Control Room (FCR) and its back rooms comprising, in essence, additional crewmembers to help meet primary mission objectives and respond to unforeseen anomalies (Figure 1). A Mars crew making real-time decisions about how to accomplish primary mission objectives (i.e., during surface extravehicular activities (EVAs)) or how to respond to unforeseen, time-critical failures will have to rely on their own knowledge assisted by decision-support systems, whose information would be limited to scenarios that were anticipated before the mission. The NESC methodology provides a systematic, repeatable, and data-driven means of assessing, based on today’s limited understanding of Mars vehicle systems, whether the capabilities that would exist within a given crew size would be adequate to accomplish mission objectives and successfully respond to unforeseen failures, for which procedures would not exist, with potential loss of crew/loss of mission consequences and short time-to-effect.

The NESC’s quantitative methodology fills a longstanding gap in the tools for designing Mars missions. In the past, crew size determinations have been based on a limited, mostly non-quantitative understanding of the impact of crew workload on mission success and crew survival. Now, in weighing the question of whether a given crew size is adequate to ensure crew survival and mission success, decision makers can be guided by a systematic, quantitative analysis.



The enormous amount of experience and expertise on the ground during ISS missions is distributed among several teams. In the Mission Control Center (MCC) front and back rooms (FCR + MPSR) there are 50+ operators on console and 20+ specialists on call. Operators possess ~500 years combined *on-console* experience and 600+ years combined *relevant* experience. In the MER there are 30+ engineers on console with ~161 years combined on-console experience and 556 years combined relevant experience (estimated based on average experience level of MART participants).

**Figure 1. International Space Station (ISS) Ground Personnel [ref. 1]**

## ***Background***

How many people should NASA send to Mars? Almost from the very beginning of Mars mission studies, there has been an awareness that to determine the necessary crew size planners must consider crewmembers' roles and tasks and the need for cross-training to provide backup in case of contingencies. Nonetheless, as the assessment team reviewed historical and recent Mars crew size assessments, the team found that there has not been a detailed, quantitative analysis of crew tasking, workload, and expertise. However, it is inescapable that a mismatch between the crew size and their workload, and the level of expertise they must possess to handle unforeseen failures, increases risk to mission success and crew safety.

To fill this gap in the Agency's capability for determining crew size for missions to Mars, the NESC has developed a methodology for NASA to perform systematic, repeatable trade space analysis comparing crew size against trade space dimensions, using quantitative data from human performance modeling. The proposed methodology is based on work conducted for the Department of Defense (DoD) on future military missions and on recommendations from a Naval Postgraduate School (NPS) review of DoD manpower determinations.

The assessment team turned to the NPS to understand how the military has considered crew size in the past. In support of the assessment, two NPS graduate students conducted literature reviews and structured interviews on DoD policies and guidance for determining crew size [ref. 2]. While the military has established methodologies, protocols, and procedures for manpower determination (i.e., the workload of an individual), the NPS found that, to date, the military has not used these methodologies for crew size determination.

Like the DoD, NASA has processes for using workload measures in the design and development of vehicles and operations. The NASA Task Load Index (NASA-TLX), developed by Ames Research Center (ARC) as a tool for cognitive workload rating, is one of the most recognized workload measures in human factors research. However, while the DoD and NASA have established qualitative and validated workload and human performance models, neither organization utilizes their models in trade space decision-making for crew size determination.

In further literature review, the assessment team found there was a DoD-funded contractor team developing a methodology for tradeoffs in crew size determination for DoD missions. In their work, the DoD-funded team approached the problem by recognizing that determining crew size is a "form of function allocation" [ref. 3] where mission functions are allocated across the humans and automation where the focus is on "the number of human operators necessary for a safe and successful mission" [ref. 4]. The DoD-funded team developed a methodology for considering trades in crew size given the allocation of functions between the human operators and automation using human performance modeling to consider the workload on the human operators. The team developed a framework for evaluating tradeoffs based on model outputs, recognizing that there is not a "best" allocation of functions, nor is there a "best" crew size; rather there are tradeoffs in factors (e.g., cost, risk, and mission success).

## ***About the Proposed Methodology***

The assessment team adapted the steps in the DoD-funded methodology as follows:

- Gather Mars Mission Information
- Determine Use Cases to Model

- Create a Trade Space Evaluation Framework
- Conduct Human Performance Modeling
- Perform Trade Space Analyses

The assessment team first gathered information on the Mars mission environment, the Agency’s mission objectives and science goals, and information on the mission architecture necessary to build human performance models. NASA’s Human System Risk Board (HSRB) recognized that there are “unchangeable aspects of the space environment” that pose a risk to crew [ref. 5]. The five main hazards of the spaceflight environment harmful to humans are identified as: altered gravity; radiation; isolation and confinement; a hostile, closed environment; and distance from Earth [ref. 5]. While each of these may impact crew size, most critical to this assessment is that the distance from Earth impacts real-time communication. The assessment team interviewed personnel from NASA’s Space Communications and Navigation (SCaN) Program who provided information on the possibilities for the communication infrastructure to support communication among the crew in the Mars vicinity and between the Earth and Mars.

The Agency published their most recent set of mission objectives and goals for Mars in their *Moon to Mars Objectives* publication dated September 2022 [ref. 6]. The assessment team identified objectives most related to this assessment and considered these when selecting use cases to model.

Since NASA has not defined the architecture for Mars missions, the assessment team created models based on International Space Station (ISS) vehicle and operations, given both that ISS is currently the best analog for a mission to Mars and that ISS operational data provided the team with the level of detail needed to build the models. The assessment team was aware of the limitations of using ISS as an analog for Mars; however, this is how predictive models are built – based on the best available information.

The fundamental difference between Mars missions and all previous spaceflight missions is that there is a subset of the functions performed real-time by the teams in the MCC and Mission Evaluation Room (MER) in Houston, Texas, and the Payload Operations Integration Center (POIC) in Huntsville, Alabama, that of necessity will be required to be shifted onboard, to the humans or automation. The assessment team took the approach of initially allocating the real-time duties of these ground personnel to the crew, recognizing that future work will be needed to consider which of these tasks might be automated or even eliminated (accepting the cost and/or risk of doing so).

The assessment team set criteria for candidate use cases to model that include use cases necessary to meet primary mission objectives and use cases to respond to unforeseen failures. The assessment team gathered candidate use cases based on previous work on ISS high-risk, critical skills, research on autonomous tasks for Mars, and through subject matter expert (SME) interviews conducted by the assessment team. The team then considered use cases that would likely require high manpower, high mental workload, or a high level of expertise in such a way as to drive crew size requirements.

The assessment team selected four uses cases to model for this assessment. Three of the use cases were modeled using the Improved Performance Research Integration Tool (IMPRINT), a human performance modeling platform built for the military to model workload at various levels.



The fourth use case was analyzed using a model of human expertise developed independently by the assessment team.

The three IMPRINT models were built based on Mars mission use cases:

- **Intravehicular (IV) Operations for Planetary Surface EVA Model:** Modeling the mental workload of the IV Mars crewmembers supporting a planetary surface technical EVA.
- **Robotic Arm Assisted EVA Operator Model:** Modeling the mental workload of a Mars crewmember controlling a robotic arm manually or in an automated control mode.
- **Mars Transit Crew Model:** Modeling the level of engagement (i.e., daily workload) of the Mars crew on the transit to Mars.

The fourth custom-built model was based on a Mars mission use case:

- **Personnel, Expertise, and Training Model:** Modeling crew expertise necessary to meet primary mission objectives and respond to unforeseen failures.

These models were developed with support from experienced crewmembers, flight directors, a payloads operations director, a flight surgeon, flight controllers, and instructors. The models allow for the consideration of complex mission operations, as in the IV Operations for Planetary Surface EVA model, and consideration of mission functions in the Personnel, Expertise, and Training model.

To develop an evaluation framework for considering modeling results against trade space parameters, the assessment team leveraged the work on crew size conducted for the DoD. The DoD-funded team developed a set of eight dimension for trade space analysis: operational impact, system resilience (where the human is part of the system), human performance, team coordination, cognitive, organization constraints, costs, and technology capabilities [ref. 4]. The assessment team added a ninth dimension: human health. This listing is intended to encompass all the parameters that should be considered in trade space analysis of crew size, while acknowledging that some factors (e.g., cost) are not considered in human performance modeling.

The assessment team conducted analyses of modeling results using the evaluation framework. While recommendations on crew size are outside the scope of this assessment, results of these and future analyses can be used to make recommendations to decision-makers as they consider potentially competing factors in deciding on the crew size for human Mars missions.

### ***Models and Findings***

A human performance model simulates a human operator's task performance in complex and dynamic operations with an executable task network diagram. The assessment team conducted two different types of analysis using IMPRINT human performance modeling, namely: 1) detailed human performance models of crewmember's workload performing specific activities (i.e., Operations models), and 2) higher-level manpower analysis models that focus on crew utilization over longer periods of time, including during periods in which unexpected events occur (i.e., Force models).

If Mars missions include the challenges associated with limited crew sizes along with Earth-independence due to communication delay/blackout, then high crew mental workload or high utilization could have significant operational consequences. The Mars crew will perform tasks

that are presently performed by the ground, and a detailed analysis of this task reallocation could help to predict potential overload conditions. It may be assumed that the crew is more reliant on automated systems to accommodate this increase in workload. However, these automated systems could fail, while at the same time causing a decrease in the crew's situation awareness of the tasks they are performing. A crew experiencing high mental workload, and thus reduced capacity for resilient performance, may not notice, diagnose, or correct failures in a timely manner, and may even commit errors that could induce additional problems. Even in well-understood commercial aviation systems that have undergone rigorous operational certification, airline pilots intervene to address aircraft malfunctions on 20% of normal (routine) flights [ref. 7]. Thus, it is likely unrealistic to expect that automation system failures on Mars missions will be rare "corner-case" events.

As research shows, humans are a "resource necessary for flexibility and resilience" in complex engineered systems [ref. 8]. Human Mars missions will only increase in complexity compared with the challenges of low-Earth orbit (LEO) and lunar missions, and it is critical that human performance is appropriately considered in the design of these missions. Results from human performance modeling can be used in considering the workload and associated adaptive capacity of the crew, among other factors in the trade space, as planners weigh trades in designing missions and as decision-makers determine crew size.

#### ***IV Operations for Planetary Surface EVA Model***

The purpose of the IV Operations for Planetary Surface EVA model is to examine the real-time activities (e.g., performed by the MCC for ISS EVAs) necessary to support astronauts engaged in a Mars surface EVA and produce an estimate of the workload that would be experienced if these activities were performed by crew in Mars orbit, without the ability for real-time communication with Earth. An Operations model built with the IMPRINT modeling platform was used to produce workload estimates.

The scenario was based on a Mars surface EVA in which two astronauts perform a technical task. Although the main purpose of Mars EVAs will be scientific activities (e.g., geologic sample collection), there is a possibility that some technical EVAs involving assembly or maintenance may be required. The focus of the model was the workload of the IV personnel who support the EVA crewmembers, rather than the EVA crewmembers.

The assessment team conducted a real-time, remote observation of MCC activities during ISS EVA 79, observed EVA 84 from the MCC, analyzed voice loop recordings of EVA 79, and conducted 12 structured SME interviews with personnel supporting the EVA. The team created human performance models for five MCC positions supporting the EVA: Ground IV, flight director, EVA flight controller, EVA Task flight controller, and extravehicular mobility unit (EMU) flight controller. The assessment team created combined models of the flight control positions to determine if two IV crewmembers supporting two EV crewmembers, and a total Mars crew size of four, could successfully complete an EVA.

The assessment team found that the IMPRINT modeling results predict that during a Mars surface technical EVA conducted at the pace of an ISS EVA, workload for an IV crewmember performing the combined duties of the present-day EVA, EVA task, and EMU flight controllers will be unacceptably high. Based on analysis of IMPRINT modeling results and SME evaluations by MCC EVA flight controllers, two crewmembers orbiting Mars would not be able

to adequately manage the workload necessary to provide real-time IV support to two crewmembers performing a technical EVA on the surface of Mars.

Even though there are limitations inherent in the EVA models presented in this report, and these results should not be considered final, successfully conducting planetary surface EVAs is the single most important mission objective for Mars. It is critical that NASA ensures a Mars crew can conduct EVAs independent of Earth. Future modeling of planetary surface EVAs should consider the pacing of Mars surface EVAs, examine the tasks and workload of ground personnel who provide real-time support of EVAs, and include potential advances in spacesuits and operational concepts under development that might offload workload from a Mars IV crew.

### ***Robotic Arm Assisted EVA Operator Model***

The scenario modeled in the Robotic Arm Assisted EVA Operator model was to conduct a robotic arm assisted EVA on a Mars transit vehicle at a distance from Earth that precluded real-time MCC interactions. The assessment team built an Operations model in IMPRINT for this scenario. The team conducted a real-time observation of MCC activities during ISS EVA 80, which included an EVA crewmember affixed to the arm. The assessment team analyzed voice loop recordings of the EVA, reviewed operational procedures, interviewed a representative from the Canadian Space Agency (CSA) on anticipated enhancements of their robotic arm, and conducted structured SME interviews with robotics flight controllers and of the crewmembers operating the arm for EVA 80.

The assessment team created models of robotic arm operations with a single IV crewmember controlling the arm manually and controlling the arm with automation. The team assessed the change in workload for the primary arm operator when a second crewmember was available for support. The assessment team investigated the impact of varied levels of autonomous robotic arm control, effectiveness of alerting support, and crewmember workload management practices. Among the results from this initial IMPRINT model, the team found a second crewmember may be necessary to mitigate unacceptably high workload of the crewmember operating the robotic arm manually.

With this model, the assessment team analyzed the effects of stressors (e.g., sleep debt). For example, IMPRINT modeling results predict that sleep debt increases mental workload and degrades performance as evidenced by extended performance times. This emphasizes the importance of considering similar stressors (e.g., fatigue) when deciding on crew size.

### ***Mars Transit Crew Model***

The purpose of the Mars Transit Crew model was to consider the tasks currently performed by the MCC that will need to be shifted to Mars crews, and the implications of this function reallocation for crew size. The assessment team utilized an IMPRINT Force model to perform a higher-level analysis of the crew's ability to handle the anticipated workload during a 9-month Mars transit mission, focusing on crew utilization and manpower requirements.

To build the necessary IMPRINT Force model, the assessment team worked with a flight director and payloads operations director to develop a list of assumptions for Mars missions (e.g., MCC is prime for nominal commanding, crew is prime for commanding that requires real-time verification). With this set of assumed tasks in hand, the assessment team conducted structured interviews with flight controllers to document the tasks related to each vehicle system or operation that would likely be shifted from MCC to the Mars crew.

Planned tasks that would be shifted to the crew included daily health and status checks of information technology (IT) equipment, safing for maintenance tasks (e.g., powering down equipment prior to performing maintenance), tasks associated with daily operations, and in-flight training to ensure the crew would be able to retain necessary skills and understanding throughout their mission. While the assessment team recognizes that some of these tasks may be considered candidates to automate, the team chose for this initial build of the Mars Transit Crew model to include all tasks currently performed by humans and not currently anticipated to be automated.

Unplanned tasks included medical events; responding to vehicle system emergency, caution, warning, and advisory events; conducting vehicle maintenance; and responding to a major incident or unforeseen failure. The assessment team gathered relevant source data for each category of unplanned task and analyzed the data sets with appropriate statistical methods to predict the rate of the event occurrences during a 9-month transit to Mars. The team also analyzed the impact of each event on the affected crewmembers' work hours. Given the uncertainties in the source data, the assessment team considered IMPRINT results with average values of all task categories and results with 75% confidence of all categories to represent a conservative bound on the average.

The assessment team built two predictive models of Mars transit scenarios, using Mars-unique planned and unplanned tasks occurring at the average and 75% confidence levels. The two Mars-unique models were used to compare IMPRINT Force model results with a model of ISS tasks.

The assessment team found that IMPRINT modeling using ISS-equivalent task assumptions predicts that more than six crewmembers will be needed to achieve the same number of work hours on a Mars transit as on a four-person ISS mission given average rates for all unplanned events, and more than seven crewmembers will be needed given 75%-confidence-level rates.

More work is needed to define Mars transit operations, and to understand critical technologies that may be required to pick up tasking from the crew before these data can be used to inform recommendations on crew size (noting again that recommendations on crew size were outside the scope of this assessment). Nonetheless, the results show the necessity of considering ongoing, daily workload in crew size decision-making.

### ***Personnel, Expertise, and Training Model***

Based on ISS historical data, there is a very high likelihood for Mars mission of unforeseen failures with loss of crew/loss of mission potential and short time-to-effect that could lead to actual loss of crew/loss of mission outcomes. The assumption by the Human System Integration Architecture (HSIA) Risk team is that an unforeseen failure that must be safed within ~24 hours and up to ~72 hours will require the Mars crew to respond independently from the MCC given the communications delay/blackout with Earth. The Personnel, Expertise, and Training model was designed to provide the capability to consider the trade space of crew size and level of expertise in the real-time environment, where the crew's expertise is a necessary component for mitigating the risk of these unforeseen failures. This custom model was built using the Excel<sup>®</sup> spreadsheet add-on simulation tool Crystal Ball.

The Personnel, Expertise, and Training model is an optimization model embedded with quantitative training data designed to balance the training workload across a crew of a given size. The model outputs pre-mission training hours for each crewmember and outputs a Mars Crew Qualifications and Responsibility Matrix (CQRM), which comprises a listing of crew capabilities/qualifications across the systems, operations, and payloads for each vehicle in a Mars

mission architecture. The model assumes continual but communication-delayed support from the MCC.

To consider the expertise necessary for a Mars crew, the assessment team identified areas of responsibility for each vehicle in a given Mars mission architecture: the Multi-Purpose Crew Vehicle (MPCV) spacecraft, the Transit Habitat, the Mars Descent Vehicle (MDV), the Mars Rover, and the Mars Ascent Vehicle (MAV). The team assigned crew responsibilities applicable to each vehicle that included piloting, emergency response, activation/deactivation, inventory and stowage, vehicle system operations, structures and mechanisms, IV maintenance and repair, habitability, imagery/video, EVA operations, crew medical response, medical operations, robotics operations including EVA robotics and track and capture, and transit and planetary surface research payloads. The team created a list of Mars mission qualifications to assign qualification levels required for each responsibility where a higher level of qualification indicates a higher level of knowledge and capability. The team gathered applicable crew and flight controller training data documented in NASA's Fox learning management system.

From the model outputs, SMEs compared flight-assigned Mars CQRMs for different crew sizes across the dimensions of the trade space evaluation framework. The assessment team found that based on modeled crew training limits and ISS-equivalent vehicle system assumptions, a flight-assigned Mars CQRM indicates that a crew of four would not possess the necessary expertise to meet primary mission objectives or respond successfully to unforeseen failures in Transit Habitat or Rover vehicle systems with potential loss of crew/loss of mission consequences.

As with the other models, more work is needed before making recommendations on crew size using the Personnel, Expertise, and Training model. To build additional Mars CQRMs for trade space analysis, including CQRMs for the expertise needed during communication blackouts, requires further knowledge of vehicle systems, possible unforeseen failures, and Mars surface operations to make meaningful decisions on required crew qualifications.

### ***NESC Recommendations***

In late 2023, the Mars Architecture Team (MAT) asked the Agency to prioritize efforts to answer seven key questions driving the Mars architecture, where “a key architecture decision is defined as a decision whose outcomes so profoundly influences the architecture that it requires very high-level review” [ref. 9]. Two of those seven questions were related to crew size: The number of crew to the Mars vicinity and the number of crew to Mars surface. The NESC recommends that Agency decision-makers should consider the crew workload and expertise within the crew necessary to successfully accomplish the mission when considering trades in those numbers.

The methodology presented in this report for conducting systematic, repeatable trade space analysis of crew size using quantitative data from human performance modeling of crew workload and expertise provides the Agency with a new capability to guide those who wish to answer those two critical questions about crew size.

However, additional work is needed to evaluate critical technologies, training capabilities, and operational considerations for missions to inform updates to the models presented in this report. To support these efforts, the NESC recommends that the Exploration Systems Development Mission Directorate (ESDMD), Space Operations Mission Directorate (SOMD), and Space Technology Mission Directorate (STMD) should coordinate to resource a group to continue the work of conducting human performance modeling of crew workload and expertise in support of trade space analysis for decision-making on crew size for Mars missions.

## 5.0 Assessment Plan

The original assessment plan was presented to the NESC Review Board (NRB) in early 2020 and approved. However, the assessment was put on hold due budget uncertainties and scheduling impacts of COVID on ongoing assessments. The updated plan was brought to the NRB in 2021 and was approved with funding. The scope of the assessment was to develop a new Agency capability for trade space analysis for crew size for missions to Mars, including developing quantitative task analysis models using an existing modeling framework. This capability will allow NASA's decision-makers to perform trade space analyses comparing crew size for missions to Mars against multiple dimensions in the trade space, including mission design parameters. The deliverables were to include the task analysis models, a personnel model, and a candidate list of crew tasks for missions to Mars.

This report details a methodology for trade space analysis for crew size for missions to Mars and lists the main factors that should be included in a full mission analysis (e.g., costs, health requirements, and human task performance). While assessing costs and health requirements are outside the scope of this assessment, human performing modeling is within scope. This report includes a set of three human performance models using IMPRINT, a human systems integration analysis modeling platform built for the DoD to model workload at various levels, and a fourth model of human expertise developed independently by the assessment team.

The three IMPRINT models were built based on Mars mission use cases:

- **IV Operations for Planetary Surface EVA Model:** Modeling the mental workload of the IV Mars crewmembers supporting a planetary surface technical EVA.
- **Robotic Arm Assisted EVA Operator Model:** Modeling the mental workload of a Mars crewmember controlling a robotic arm manually or in an automated control mode.
- **Mars Transit Crew Model:** Modeling the level of engagement (i.e., daily workload) of the Mars crew on the transit to Mars.

The fourth custom-built model was based on a Mars mission use case:

- **Personnel, Expertise, and Training Model:** Modeling crew expertise necessary to meet primary mission objectives and respond to unforeseen failures.

The assessment team expanded on a candidate list of crew tasks for missions to Mars given the current level of understanding of the vehicles and mission architecture for the first missions to Mars.

Assumptions for each of the four models are listed within their section of this report, including assumptions regarding the Mars communication infrastructure and Mars vehicle capabilities in the context of the allocation of duties and tasks to the crew. Each of the four models are analyzed in the context of the trade space for crew size for missions to Mars against mission design parameters using a trade space evaluation framework.

## **6.0 Problem Description, Background, and Proposed Solution**

### **6.1 Problem Description**

To date, crewmembers onboard NASA's human spaceflight missions have been able to rely on real-time expertise and support from personnel in control centers on Earth to successfully accomplish their missions. For ISS missions, the flight director, flight controllers, and engineers in NASA's Mission Control Center (MCC) and Mission Evaluation Room (MER) in Houston, Texas, and the payloads operations director and payload engineers in the Payload Operations Integration Center (POIC) in Huntsville, Alabama, team with the crew to monitor and control the vehicle, vehicle systems, and payloads and provide expertise as needed. The MCC personnel are certified flight directors, flight controllers, and analysts responsible for real-time operations of the vehicle (e.g., control of vehicle core systems) and operations (e.g., EVA and robotics operations). The MER personnel are engineers who support MCC with real-time engineering analysis. The POIC payloads operations directors and payload engineers are responsible for real-time operations of payloads (i.e., scientific experiments). Additionally, the ISS crew is supported in real-time by SMEs in NASA's commercial and international partner control centers.

#### ***Ground Personnel***

The amount of support provided by the MCC teams cannot be overstated. In the MCC there are 50 or more operators on console conducting ISS operations during a typical weekday shift, with 20 or more specialists on call. The MCC is staffed continually, though with fewer personnel on the overnight and weekend shifts. These flight controllers are performing real-time duties that include operating the vehicle and vehicle systems (e.g., sending commands to core vehicle systems, performing software upgrades, responding to system anomalies, and managing crew schedules). For more complex operations, additional flight controllers sit on console. For example, during ISS EVA operations, there are more than half a dozen MCC flight controllers who support in the flight control room (FCR) and the Multipurpose Support Room (MPSR), with greater than 18 MER personnel and EVA managers [ref. 2].

MCC flight controllers not only perform a substantial amount of work "flying" the vehicle, but they also bring an enormous amount of expertise to real-time operations. All flight controllers are certified to perform their duties, receiving years of training on their specific systems or operations. An analysis by NASA's HSIA Risk team found that one shift of FCR and MPSR personnel "possess ~500 years of combined on console experience and 600+ years combined relevant experience" [Figure 1]. In the MER, "there are 30+ engineers on console with ~161 years combined experience and 556 years combined relevant experience" [ref. 2]. In the event of an unforeseen failure, the MCC stands up a separate team to work the failure so that the FCR and MPSR teams can continue to focus on operations. This additional team is referred to as Team 4 or, when International Partners are involved, as a Multilateral Anomaly Resolution Team (MART). One MART meeting contained "747 years combined relevant experience and an average experience level of 17 years" [ref. 2].

While the capability within a Mars crew to operate, maintain, troubleshoot, and repair systems and payloads is critical for mission success, many tasks will likely be performed at a tempo that allows for communication delayed/blackout exchanges with MCC to take advantage of the expertise within the flight control team on the ground. Nonetheless, there are nominal, time-critical tasks that the crew will need to perform without the real-time support of the MCC (e.g.,

piloting, EVA operations, certain robotics operations, and vehicle system commanding that requires real-time responses), shifting a large amount work from the ground to the Mars crew.

Most critical is the expertise needed to respond in real time to unforeseen failures with potential loss of crew/loss of mission consequences and short time-to-effect. Critical failures requiring the high level of expertise found only in the ground teams have occurred since the beginning of human spaceflight. For historical context, the assessment team gathered examples from Apollo missions.

*July 1969: Computer alarms during Apollo 11 powered descent*

During the powered descent, the lunar module's (LM's) onboard computer issued alarms indicating it was overloaded with tasks. The crew did not know what the alarms meant or how to respond to them, but in one of the MCC back rooms a computer expert named Jack Garman did know what the alarms meant. He told flight controller Steve Bales that if alarms did not recur they would not pose a threat to the landing. Bales informed Flight Director Gene Kranz that they were still Go, and Capcom Charlie Duke relayed that to the crew.

*November 1969: Lightning strikes the Apollo 12 spacecraft during launch*

Lightning struck the Apollo 12 spacecraft twice during the first minute of launch, disrupting the command module's (CM's) electrical power system and causing the guidance platform to lose its inertial reference. The crew reported a long string of caution and warning lights, and within seconds flight controller John Aaron responded with the suggestion, "Try SCE to AUX," a reference to the CM's Signal Conditioning Electronics (SCE) auxiliary (AUX) mode. This was highly specialized knowledge that was unknown to anyone else in the MCC or the crew. Aaron had learned about the functioning of the SCE in AUX mode a year earlier, and it was fortuitous that he was at the electrical, environmental, and consumables manager (EECOM) console on that launch. When the crew flipped the switch to put the SCE to AUX, it allowed Aaron to get his data, averting a potential abort by Flight Director Gerry Griffin. It also allowed the MCC to advise the crew on how to respond to the effects of the lighting strike.

*April 1970: Apollo 13's Command/Service Module (CSM) is crippled by the explosion of an oxygen tank*

After an oxygen tank inside the Apollo 13 service module (SM) exploded, the crew was faced with a survival situation. Close coordination with the MCC allowed them to activate their LM as a lifeboat. Calculations made by flight controllers in the MCC were essential in the crew's use of the LM engines to get back on a free-return trajectory and, later, to correct errors in their homeward flight path. MCC expertise was critical in managing limited resources, troubleshooting numerous problems, and creating procedures necessary for the crew's safe return. One of the most famous examples is the carbon dioxide scrubber that had to be rigged by the crew using a cartridge from the CM that was not designed to work in the LM. Fortunately, a solution was found by the Manned Spacecraft Center's<sup>1</sup> Crew Systems Division, who devised a way for the crew to adapt the cartridge to the LM's environmental control system using materials onboard.

*February 1971: Contaminated circuit threatens the Apollo 14 lunar landing*

While preparing for their descent to the Moon's surface, the Apollo 14 crew received an indication that an abort signal was being sent to the onboard computer, probably because of a

---

<sup>1</sup> The Manned Spacecraft Center was subsequently named the Johnson Space Center.



contaminated circuit. Had the crew done nothing, this would have resulted in aborting the powered descent immediately after it had begun. MCC contacted the Massachusetts Institute of Technology (MIT), where one of the authors of the LM's computer software wrote a patch that worked around the problem. The commands were relayed up to the crew, who entered them into the computer, and the landing was able to proceed.

*July 1971: Water leak in the Apollo 15 CM*

About 61 hours after launch the crew discovered water leaking at a high rate from the chlorination port of their potable water supply. If the problem had not been solved it would have caused the mission to be aborted (i.e., loss of mission) and threatened the functioning of the CM's electronics. Less than 15 minutes after the crew reported the problem, the MCC responded with a procedure to arrest the leak. Fortunately, the problem had occurred during preparations on launch day, and technicians had written the procedure in case the problem recurred in flight. The crew had not been told of the incident and did not have any prior information onboard about how to respond.

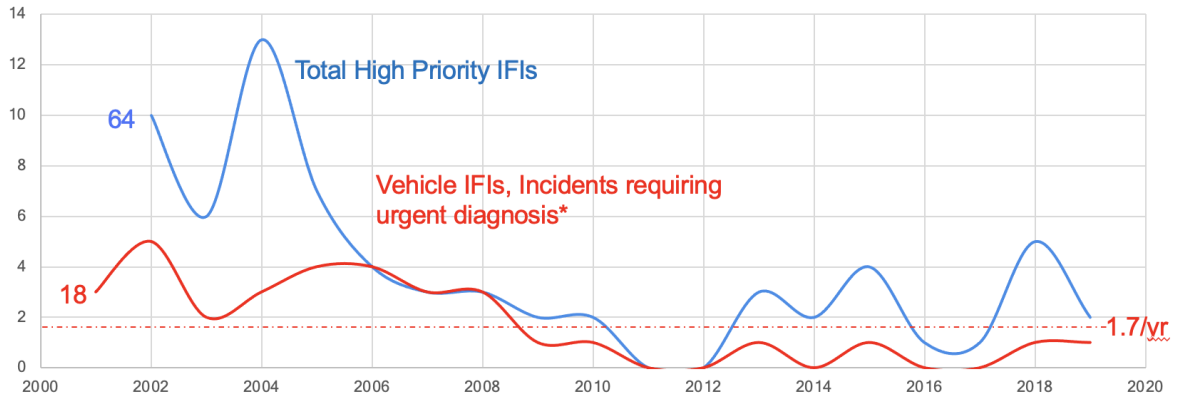
*April 1972: An engine control malfunction threatens the Apollo 16 landing*

After a normal undocking and separation from the CSM in lunar orbit, the LM crew was preparing for their descent to the Moon while their crewmate in the CM readied for an orbit circularization maneuver. As he adjusted the controls for the engine nozzle steering mechanism, the CM pilot felt the vehicle shake and realized the secondary yaw control loop was unstable. The mission remained in limbo for about six hours, while MCC engineers and Apollo contractors worked to analyze data from the spacecraft and conduct tests with duplicate hardware. Finally, the MCC established that the system was safe to use, and the mission continued successfully.



## Current Status State of Knowledge (New Evidence)

### ISS: High Priority IFIs, Significant Incidents in Vehicle Systems Requiring Urgent Diagnosis\*



\* Those with potentially high consequence outcomes (e.g., high priority IFI) **and** significant uncertainty surrounding their origins. These issues are not known emergencies but have significant time pressure to identify causality, e.g., so that cascading or common cause failure modes can be avoided.

*Figure 2. High-priority ISS IFIs [ref. 38]*

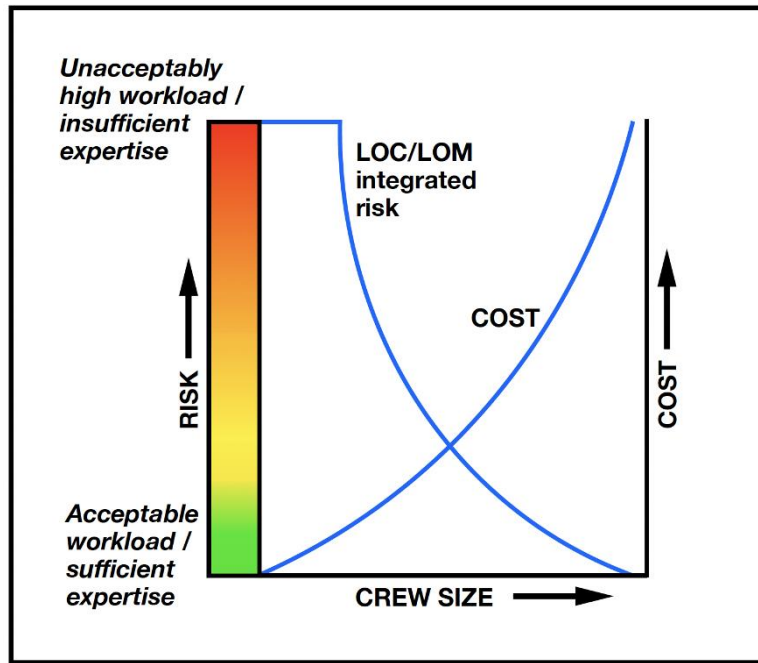
Failures that have required the highly specialized expertise in the MCC to resolve continue to be seen in current spaceflight programs. An analysis of ISS unforeseen failures, classified as items for investigation (IFIs), conducted by NASA's HSIA Risk team showed that IFIs requiring urgent diagnosis have occurred on average 1.74 times per year, where such IFIs are "those with potentially high consequence outcomes and significant uncertainty surrounding their origins. These issues are not known emergencies [i.e., those for which pre-planned responses exist] but have significant time pressure to identify causality (e.g., so that cascading or common cause failure modes can be avoided)" [ref. 38] (see Figure 2). [Note that this analysis did not include IFIs associated with EVAs.]

Based on past human spaceflight experience, it is expected that a Mars crew will be faced with unforeseen failures. To successfully address these failures, having a sufficient level of expertise afforded by an adequate crew size will be critically important.

### **Summary**

Because of the distances associated with missions to Mars, real-time communication with the MCC will not be possible. Mars missions will differ from all previous human spaceflight experience in that the crew will be required to operate independently from the large and highly experienced teams on the ground, and thus critical mission functions will have to be reallocated from the ground to the crew. However, because of the cost of spaceflight missions, NASA is working to design missions with a limited crew size. Without a systematic, repeatable process to

aid determination of crew size and expertise necessary to successfully accomplish Mars missions, NASA increases the risk to such missions in that crew sizes may be insufficient to meet mission objectives under nominal conditions and, more consequentially, the crewmembers may not have the expertise needed to successfully respond to unforeseen failures without the MCC’s real-time expertise that NASA has always relied on (Figure 3).



Notional curves convey the relationship between crew size, risk, and cost. Crew sizes too small to handle mission workload or respond successfully to unforeseen failures due to insufficient onboard expertise result in increased risk to mission success and crew safety (left curve). Increases in crew size, which reduce these risks, may likely drive mission costs prohibitively high (right curve).

*Figure 3. Notional Crew Size, Risk, and Cost Curves*

## 6.2 Background

### 6.2.1 Humans to Mars, But How Many? A Historical Review of Crew Size Determinations for Mars Missions<sup>2</sup>

*“Humans are the most valuable mission asset for the Mars exploration program and must not become the weak link.”*

— NASA ARC human factors specialist Yvonne Clearwater, 1993

*“A Mars mission is more than just Apollo on steroids; there is a quantum difference from any of our previous spaceflight experience.”*

— NASA JSC systems engineer and Mars mission architect Steve Hoffman, 2023

<sup>2</sup> Persons interviewed for this historical review are listed in Appendix A; references are listed at the end of Section 15.0.

## Introduction

Three-quarters of a century have passed since Wernher von Braun conducted the first engineering study of a human mission to Mars in 1948. During that time, dozens of study teams at NASA, its contractors, and other organizations in the U.S. and abroad have confronted what NASA mission architect John Connolly and his colleagues have called “the ultimate systems challenge.” As they wrote in 2017, a Mars mission that can be carried out with available resources and technology represents “a complex network of interconnected design choices, systems analyses, technical optimizations, and non-technical compromises.” The crew size is one in a bewildering array of considerations including propulsion type, orbital mechanics, mission duration and spacecraft technologies. Over the decades, planners grappling with the complexities of the humans-to-Mars trade space realized that the mission design must start with the crew and work outwards. Many tried to address one of the most critical factors in determining the crew size, namely the tasks they would have to perform and the impact of crew workload on mission success. But with limited resources—after all, Mars missions were too far in the future to be a priority—they were unable to carry out the analyses necessary to truly understand that impact.

Now, however, that is changing. Today, as NASA prepares to make critical choices for human Mars missions, decision-makers can utilize a new analytical capability created by the NASA Engineering Safety Center to enable quantitative assessment of a Mars crew’s workload and expertise that can be used to guide the all-important choice of crew size. This capability has been developed out of an appreciation of the inescapable fact that Mars crews will have to confront malfunctions and crises without the real-time support available to astronauts in LEO and cislunar space. The troubleshooting analyses that up to now have been shared by dozens of minds in the Mission Control Center (MCC), leveraging decades of combined training and spaceflight experience to solve never-before-encountered problems, will have to be carried out by a handful of people more isolated from Earth than any previous explorers. This fundamental reality separates Mars missions from all previous human spaceflight experience.

The historical narrative that follows shows how this daunting realization—one whose impact continues to unfold—has shaped crew size determinations over the last three-quarters of a century, providing context for the current efforts to define the first human Mars missions.

### Before NASA: Wernher von Braun’s Ambitious Martian Visions

Year	Title	Author	Crew (total)	Crew (landed)
1948	<i>The Mars Project</i>	Wernher von Braun	70	50
1956	<i>The Exploration of Mars</i>	von Braun and Ley	12	9

In 1948, three years after Wernher von Braun and his rocket team surrendered to American forces and were brought to the U.S. to jump-start the nation’s guided missile program, von Braun found himself with a bit of time on his hands. Taking advantage of the lull von Braun returned to an idea he had been pondering for over a decade, but which up to now had only existed in the pages of science fiction, a crewed expedition to the Red Planet. Determined to show that despite its staggering challenges such a mission could be accomplished, von Braun used nothing more than a slide rule for calculations as he worked out a detailed plan for the expedition, aided by several

colleagues. By 1952, the study had been published in Germany, and the following year an English translation appeared in the U.S. with the title *The Mars Project*.

By that time von Braun was becoming known to Americans as a space visionary, having penned a forecast of the coming Space Age for the widely read magazine *Colliers* in a series of articles between 1952 and 1954. Despite von Braun's optimism, *The Mars Project* must have seemed impossibly ambitious in 1952 (and even today, it still does). The plan called for ten Mars ships that would be assembled in Earth orbit by a fleet of nearly four-dozen space shuttles, each with almost twice the payload capacity of the actual Space Shuttle that would not become reality for nearly three decades. Each of the expeditionary ships, outfitted with a 'landing boat' for the trip from Mars down to the planet's surface and back, would weigh 3,720 metric tons for a total expedition mass of 37,200 metric tons, more than 88 times the mass of the completed International Space Station (ISS).

The number that really conveys the audacity of von Braun's expedition is the crew size: No less than 70 people would make the 260-day journey to Mars, with 50 of them setting foot on the surface. Von Braun did not say how he arrived at such a large number of expedition members, but historian David S. F. Portree has proposed that there may have been an Antarctic connection. In his seminal monograph *Humans to Mars: Fifty Years of Mission Planning, 1950-2000*, Portree speculated that as von Braun carried out his study in 1948, he would have been inspired by the recently completed Antarctic expedition known as Operation High Jump, which included 4,000 people, 13 ships, and 23 aircraft. "In the days before satellites," Portree wrote, "Antarctic explorers were largely cut off from the world, so experts and technicians had to be on hand to contend with any situation that might arise. Von Braun anticipated that Mars explorers would face a similar situation."<sup>3</sup>

In his introduction to *The Mars Project* von Braun justified the expedition's enormous economic and logistical costs by pointing out that they "are no greater than those for a minor military operation extending over a limited theater of war." By 1956, however, von Braun had apparently come to grips with real-world limitations, presenting a more modest plan in the book he co-authored with Willy Ley, *The Exploration of Mars*. "In order to keep the costs for the undertaking to a minimum," they wrote, the expedition was limited to 12 people, 9 of whom would land on the planet.

Even at this early date, von Braun and Ley were mindful of the human-factors elements of the mission, and *The Exploration of Mars* mentions cross-training for Mars expedition astronauts. Any of them might become incapacitated by illness or injury, they noted, so the entire crew would have to be trained to cover specialties other than their own. "Logically, then," they wrote, "the radioman must be able to take the place of the navigator, the co-pilot of the glider the place of the chief engineer, while at least three men of the crew should have a fair amount of training in medicine and simple dentistry." It was the first appearance of what would become a recurring theme in humans-to-Mars studies.

---

<sup>3</sup> In a February 2023 email to the author, Portree explained that this statement was based solely on his own interpretation of von Braun's study.

### Early NASA Mars Mission Studies Mention Crew Workload

Year	Title	NASA Sponsor	Contractor	Crew (total)	Crew (landed)
1963	<i>Manned Mars Landing and Return</i>	NASA Ames Research Center	TRW Space Technology Laboratories	6	2
1963	<i>Manned Mars Landing and Return</i>	NASA Ames Research Center	North American Aviation	3-10	?
1963	<i>Study of Subsystems Required for a Mars Mission Module</i>	NASA Manned Spacecraft Center (now Johnson Space Center)	North American Aviation	4-6	2
1963	<i>Study of a Manned Mars Excursion Module</i>	NASA Manned Spacecraft Center (now JSC)	Philco Corp. Aeronutronic Division	4-6	3

In the early 1960s, even as NASA tackled the enormous challenges of the Apollo lunar landing program, farsighted engineers at several NASA centers were already looking to a future they hoped would include human missions to Mars. In 1963, two centers funded Mars mission studies that demonstrated at least some awareness of the importance of workload as a determining factor in crew size. One was carried out for the Ames Research Center (ARC) by TRW, whose report stated that in light of “a brief human factors study” including an analysis of crew tasks, “a crew of eight...is desirable and seven is a minimum.” However, in the next sentence they noted that “substantial improvements in subsystem reliability and maintainability could allow a reduction in crew requirements.” Apparently, they believed those improvements would become reality: Their report assumed a six-person crew, with two landing on the Martian surface. The TRW study reflected a challenge that would confront all Mars mission planners: The pressure to rely on yet-undeveloped technologies as a means of reducing crew size.

Crew workload also figured in two Mars studies funded that year by the Manned Spacecraft Center (MSC, now the Johnson Space Center). At this time the Houston center was well along in creating the Apollo spacecraft, including a command module that would carry three people (a crew size based on the minimum number that would allow round-the-clock watches like those on naval vessels) and a lunar module that would bring a pair of astronauts down to the lunar surface and back. For Mars, however, MSC told the contractors to assume a four-person crew but to design the mission’s habitation module to handle as many as six people.

MSC chose North American Aviation, prime contractor for the Apollo command/service module, to study the transit vehicle, which would house four astronauts during the trip to Mars and back and two in Mars orbit during the surface operations phase of the mission. Their study included a workload analysis that revealed the impact of a small crew size on the mission’s scientific accomplishments. The astronauts would spend most of their seventeen-hour days on systems monitoring and controlling the vehicle, the engineers noted, and because of subsystems’

limited reliability additional crew time would be required for onboard repairs. If malfunctions piled up, “noncritical activities, such as scientific experimentation, training, and recreation would have to be replaced with the maintenance function as required.”

The design study of the mission’s lander, which was carried out by the Aeronutronics division of Philco, also included a task analysis that indicated that the mission could be accomplished with a small crew—but not as small as had been prescribed. Philco’s engineers reported that contrary to the two-crew minimum specified for the lander, three people would be needed to obtain “a reasonable scientific and engineering data return from the surface of Mars.” The lander crew would consist of a Captain-Astronaut-Scientific Aide who would have “complete authority during flight phases” and would assist the two scientists during surface activities; a First Officer-Scientist-Astronaut trained in geology who would also handle navigation during flight and advise on the choice of the mission’s landing site, and a Second Officer-Scientist-Astronaut who would conduct biological studies, monitor the lander’s systems and the health of the crew, and manage the life support equipment. And in what may have been an early recognition of the need for in-situ IV support, the study stated that two astronauts would conduct EVAs while the third remained inside the lander.

Based on available documents, these brief forays into the implications of Mars crew size seem to be unique in NASA’s early history. Although the Agency’s studies of Mars missions would continue through the end of the 1960s, the 1963 ARC and MSC efforts marked the last time that human factors would play a role in Mars crew size determinations in the Apollo era.

**1988: Words of Caution on Minimum Crew Sizes**

Year	Title	NASA Originator	Crew (total)	Crew (landed)
1988	<i>Human Expeditions to Mars</i>	NASA Headquarters Office of Exploration	8	4
1988	<i>Lunar Outpost to Early Mars Evolution</i>	NASA Headquarters Office of Exploration	8	8

In the late 1980s, after nearly two decades in which the Red Planet all but disappeared from planners’ agendas, human Mars missions enjoyed a resurgence at NASA. In 1988 NASA Headquarters’ newly formed Office of Exploration ordered a range of studies of human missions to the Moon and Mars, including landings on Mars and a rendezvous with the Martian moon Phobos. The Mars landing case studies, entitled “Human Expeditions to Mars” and “Lunar Outpost to Early Mars Evolution,” featured eight-person crews, with four or eight people landing on the surface. The study report said nothing about the rationale for this crew size, but it did include a fascinating discussion of minimum crew size written by a young JSC systems engineer named Kyle Fairchild, who soaked up the wisdom of the veteran engineers, scientists, and mission planners participating in the study. His comments highlighted the daunting and sometimes surprising complexities of the crew-size issue, and explicitly addressed two opposing pulls—the desire for a larger team of astronauts to ensure mission success, and the mass and cost penalties of sending them to Mars.

Fairchild observed that the combined mass of the astronauts and the systems needed to support them had often been the leading parameter used to determine a mission’s cost because “mass is

the easiest parameter to quantify.” But he noted that minimizing the crew size, he noted, can actually increase costs due to the expensive technology development required to compensate for the tasks that would otherwise have to be performed by humans. A smaller crew would also bear the burden of a heightened need for cross-training. “For example,” he wrote, “the diverse skills of commander, physician, scientist, and engineer might have to be compressed into two people.” Fairchild clearly foresaw the need for a data-driven assessment of the implications of reduced crew size: “To quantify this impact, it is necessary to do a functional decomposition of the entire mission, then determine the amount of crew time necessary to perform each function, crew endurance limits for each function, and the sequence of functions.”

On the idea of relieving the crew’s workload with automated systems, Fairchild sounded a cautionary note. In contrast to machines that are best suited to performing routine tasks, he observed, humans do best when they are required to perform “new innovative tasks that are initially poorly understood.” Space Shuttle missions had demonstrated this again and again as astronauts devised “innovative fixes for unanticipated contingencies.” But in contrast to the near routine of shuttle flights, Fairchild noted, “the relatively unknown environment and situations that will be encountered in a Phobos or Mars mission [mean that] crew contributions will be even more critical. Considerable advances will be required in artificial intelligence, automation, and robotics before it is truly viable to replace crew members with machines.” He warned that future program managers betting on the development of such systems to stay within cost and schedule constraints “will find themselves in the unenviable position of trusting in technology development they largely have no control over...Gambling an entire program on state-of-the-art forecasts can be very risky.” It was a remarkable observation to make in 1988, and one that could easily be made today.

**1992: Skill Mix Gains New Importance for Crew Size**

Year	Title	NASA Originator	Crew (total)	Crew (landed)
1993	<i>Mars Exploration Study Workshop II</i>	NASA Headquarters	6	6

NASA’s humans-to-Mars studies got an enormous boost in July 1989 when President George H. W. Bush called for a Space Exploration Initiative (SEI) including a human return to the Moon and expeditions to the Red Planet. Ultimately, however, SEI proved to be untenable—largely because, as JSC mission architect and cost analyst Humboldt Mandell later wrote, “NASA management had little concern for the costs of human exploration” because they believed the new program would inevitably be high on the list of national priorities. For the 90-day study mounted by the Agency in response to Bush’s SEI speech, cost estimates were not generated until the mission designs had been completed. The resulting \$200-billion price tags for each of the study’s Moon and Mars alternatives, Mandell wrote, “would have required a doubling or tripling of the current NASA budget for up to thirty years,” a realization so alarming that NASA management decided to recall and embargo all cost estimates connected with the report. Nevertheless, Mandell wrote, “the damage was done. The perception abounded, throughout NASA and the external community, that costs of up to \$500 billion would be required to implement Moon and Mars exploration.” Things could have been different, he said, if costs had been a concern from the outset.



By 1992 SEI was all but dead, but there was still enough momentum to support a Mars Exploration Study Team that included engineers and scientists from across the Agency, along with a few outside researchers and Mars enthusiasts. In the spring of 1992, the team gathered at ARC to work out a new and more affordable humans-to-Mars plan, and especially, to evaluate the Design Reference Mission<sup>4</sup> that was in preparation. Exploration Program mission architects Kent Joosten, David Weaver, Bret Drake and John Connolly were among those who deliberated at Ames. Connolly remembers the gathering with enthusiasm. “That was a hell of a workshop,” he says. “It was a cast of the most brilliant folks you could have.”

The participants included ARC human factors specialist Yvonne Clearwater, who had joined NASA in 1984 after working on design issues for military bases in extreme environments where levels of isolation, confinement, and risk were high. “In these settings,” she recalls, “skill mix and cross-training were key to determining not only the size and composition of the crews, but also served as drivers for many other aspects of mission planning and concept design.” By 1992, she had been applying this fundamental understanding to Mars missions, and for the ARC workshop she conducted an analysis of “the minimal size crew needed to achieve the combined science and habitability objectives of the Mars surface mission.” Her focus stemmed from an understanding that during the trip to and from Mars, the crew would likely be occupied with training activities and physical conditioning, while the mission-critical tasks would be accomplished on the Martian surface.

Clearwater began with the assumption that while the astronauts were living on Mars they would have “weekday schedules similar to a normal life regime,” with 9 hours for work, 8 hours for sleep, 1 hour each for hygiene and exercise, 2 hours for meals, and 3 hours for rest and relaxation. On weekends the schedule included only “essential tasks and chores which could be carried out in less than 5 hours per crew member.”

Next, Clearwater identified the skills required for the surface mission:

- Operation, maintenance, and repair of mechanical, electrical, and electronic systems
- Tool making
- General practice medicine plus surgery, biomedicine, and psychology
- Geological studies including geochemistry, paleontology, geophysics, meteorology, and atmospheric science
- Biological studies including botany, ecology, agronomy, and soil science
- Management/planning
- Communications
- Computer sciences and database management
- Food preparation and greenhouse operations
- Vehicle control and navigation, including teleoperated rover
- Journalism
- Housekeeping

Finally, Clearwater summarized the technical fields required: mechanical engineer, electrical and electronics engineer, geoscientist, life scientist, and physician/psychologist. Each of these were important enough to be assigned as a primary specialty to one crewmember, with at least one

---

<sup>4</sup> NASA’s practice of creating a Design Reference Mission to guide the design of hardware and missions dated back to the early years of the Apollo Program.

other crew person being cross-trained as a backup. “A wide variety of tasks would have to be handled by each crew member,” she noted, “including support tasks as well as tasks of command and communications. It is assumed that technical individuals would be cross-trained for these responsibilities.” Nevertheless, Clearwater concluded that “the surface mission can be conducted with a minimum crew size of five, based on technical skills required.” But she added an important caveat: “Loss or incapacitation of one or more crew could significantly jeopardize mission success. Therefore, a minimum crew size of seven or eight may be required to address the risk issues. Currently, the reference mission is built on the assumption of a crew of six.”

However mindful the ARC workshop participants were about SEI’s painful lessons, when it came to crew size their choice seems to have been driven less by cost than reducing risk to mission success. As Clearwater noted, there were overriding considerations for the first human Mars expedition. Ensuring the crew survived the journey was not enough; the real objective was “to learn about Mars and its capability to support humans in the future.” And she articulated a compelling mandate: “Humans are the most valuable mission asset for the Mars exploration program and must not become the weak link.”

Clearwater’s analysis did not address key issues, including the amount of time it would take to train a Mars crew for all the roles they would need to master. Nevertheless, it was an important effort that took the consideration of workload in crew-size determinations to a new level, and its influence would be seen in NASA’s Mars mission planning for many years to come.

**1997: NASA Publishes a Design Reference Mission for Mars**

Year	Title	NASA Originator	Crew (total)	Crew (landed)
1997	<i>Human Exploration of Mars: The Reference Mission of the NASA Mars Exploration Study Team</i>	NASA Headquarters	6	6

By 1993, when the report of the ARC workshop was published, JSC systems engineer Steve Hoffman was a veteran of Mars mission studies, having begun his involvement in 1986 as a contributor to the report of the National Commission on Space. Hoffman had not attended the ARC gathering, but hearing about it sparked his interest, and soon he was interviewing participants and collecting their presentation materials. Over the next several years he and his colleagues incorporated the workshop’s findings into NASA’s first published Design Reference Mission (DRM) for a human Mars mission, which was released to the public in the summer of 1997.

The DRM began its discussion of crew size with the acknowledgement of that parameter’s impact on the scale of every system required for the expedition, and therefore, the mission’s cost—but in an echo of Kyle Fairchild’s caution a decade earlier about the hidden costs of technology development, it noted that “[t]he size of the crew also is probably inversely proportional to the amount of new technology which must be developed to allow all tasks to be performed.” Nevertheless, there was no way around the requirement for “highly autonomous” systems, given the fact that the astronauts would be deprived of real-time support from Earth. The level of system automation achieved, the authors noted, would be an important consideration for crew size.

The DRM included Clearwater's chart of Surface Mission Skills from the 1992 ARC workshop and repeated her assessment that a crew of five could accomplish the surface mission, with the same caveat about the potential impact of injury or illness that drove the baselining of a six-person crew. However, there was new language amplifying crew roles:

- “Medical treatment. In a 3-year mission, it is very likely that an accident or disease will occur. At least one medically trained person will be required as well as a backup who is capable of conducting procedures under the direction of medical experts on Earth (through telemedicine).”
- “Engineer or technician. A person skilled in diagnosing, maintaining, and repairing mechanical and electrical equipment will be essential. A high degree of system autonomy, self-diagnosis, and self-repair is assumed for electronic systems; however, the skill to identify and fix problems, in conjunction with expert personnel on Earth, has been repeatedly demonstrated to be essential for space missions.”
- “Geologist-Biologist. A skilled field observer-geologist-biologist is essential to manage the bioregenerative life support system experiment. All crew members should be trained observers, should be highly knowledgeable of the mission science objectives, and should be able to contribute to the mission science.”

Although the DRM assumed six crew, it acknowledged that number might not be large enough to handle some situations. “For example, EVAs are likely to require at least two people outside the habitat at any one time in order to assist each other. A third person is likely to be required inside to monitor the EVA activities and assist if necessary. If other tasks (repair, science, bioregenerative life support system operation) are required to be done simultaneously, the number of crew members may need to be increased.” And although it was too early in the design of the reference mission to articulate mission rules for specific contingencies, the authors noted that “the choice of what the crew will be allowed to do or not do can impact the size of the crew. For example, during exploration campaigns, mission rules may require that some portion of the crew be left in the main habitat while the remainder of the crew is exploring in the mobile unit. It will be necessary to have a backup crew to operate a rescue vehicle in case the mobile unit has a problem. If the exploration crew requires three people, the requirement to have one driver for a backup unit and one left at the outpost implies a crew of not less than five.”

Like the ARC workshop report, the DRM's crew-size assessment lacked any quantitative analysis to support its recommendations on crew size. “There was never an effort to try and go do that,” Hoffman recalls. “It could have been due to a number of things. I mean, there was still a lot of skepticism about a Mars mission being so far away [in the future], why do we have to spend resources on that?” And although the DRM discussed the preflight training a Mars crew would require to accomplish the mission, it did not offer any estimates of the amount of training or the time that would be required. There were also divergent statements about the feasibility of adequately preparing the astronauts for what they might have to deal with. On the one hand, the DRM stated that “training for critical events will ensure that crews are adequately prepared for nominal and contingency situations.” But it also acknowledged that “[s]ome needs may not be anticipated during crew preparation and training, which will significantly challenge the management and operations systems to support the crew....”

Finally, as Hoffman recalls, the DRM focused on tasks that would have to be accomplished during the transit to and from Mars and in orbit around the planet, while surface activities

received relatively little attention. “In my opinion, there was a glaring hole about what are they doing once they get on the ground,” he says. “The whole idea was to get there and do things on the ground, and yet nobody was paying attention to that.” That realization would later motivate Hoffman to create a Surface Reference Mission that would be released in 2001.

Still, the DRM was an important milestone in the evolution of thinking about Mars crew size. With the July 1997 release of *Human Exploration of Mars: The Reference Mission of the NASA Mars Exploration Study Team*, a six-person crew became a standard that would endure for nearly two decades—although not without some challenges.

**1999-2000: Challenging the Six-crew Paradigm**

Year	Title	NASA Originator	Crew (total)	Crew (landed)
1999/2000	<i>Operations Concept Definition for the Human Exploration of Mars</i>	Human Exploration Operations Team / NASA HQ Office of Exploration	4	4

Sometime in the late 1990s the Office of Exploration recruited members of JSC’s Mission Operations Directorate to support NASA’s ongoing studies of human Mars missions. As MOD’s Tony Griffith recalls, he and his colleagues soon realized that they could bring to the work an operations-based perspective that had been missing up until then. Issues such as “failure tolerance, robustness, having the lack of propagating failures so that a single failure doesn't become two or three or five...those are very ops-centric views,” Griffith says. “How do you manifest and accept risk? How do you plan missions that don't depend on everything being perfect to succeed so that...things can fail elegantly and not just bring the whole thing to a screeching halt?” To bring these considerations to humans-to-Mars planning, Griffith led the Human Exploration Operations Team (HEOT), which included about two dozen specialists from JSC and KSC, in the creation of a document called *Operations Concept Definition for the Human Exploration of Mars*. It was first issued within NASA in the spring of 1999, with a revised edition released a year later.

Significantly, the first item on HEOT’s list of Operational Assumptions and Requirements read, “Human planetary exploration missions shall be economically feasible.” That mandate led the team to challenge the six-person crew assumed by the 1997 DRM. Reducing the crew size to four would mean a significant savings of mass and cost, but could it be done without jeopardizing crew safety or mission success? To answer that question, they focused on Martian surface EVAs because, Griffith explains, “if you can't do EVA with the crew size you have, you can't do the mission.”

HEOT’s assessment began with a survey of crew sizes on human spaceflight missions in low Earth orbit, including the Space Shuttle (five to seven), the Soviet/Russian Mir space station (two to three), and the ISS (three during assembly, seven during operations). In some ways, they wrote, the ability to conduct the Mars surface mission safely and successfully with four astronauts<sup>5</sup> would be based directly on those past experiences. Shuttle crews tasked with carrying

---

<sup>5</sup> Griffith’s team started with the same assumption used in the DRM, that the entire crew would land on Mars, leaving the transit vehicle unattended in orbit.

out multiple EVAs included two EV pairs (“the buddy system is critical to success and safety”), with at least one of the remaining astronauts providing IV support by “[keeping] track of the timeline, consumables, tools, and tasks.” The same EV/IV protocol had also been used by cosmonauts on the Russian Mir space station. For Mars, having four astronauts on the surface would allow “two EVA teams for surface exploration. While one pair was outside, the second pair would remain inside, with one individual performing IV support, and the other monitoring vehicle health/status.” Furthermore, “with sufficient time off to prevent exhaustion and burnout, these two pair of EV teams would perform exploration EVAs on alternating days within the crew scheduling constraints and as the mission schedule demands.”

Even as they looked to past experience in LEO for their crew size recommendation, HEOT acknowledged the fundamental challenges for a Mars crew created by the delay in communications, which could be up to approximately 22 minutes each way. (The authors also mentioned the blackout created when Mars is behind the Sun as seen from Earth, a period that can last up to three weeks, and proposed using a communications satellite as a relay.) Because of the delay, they noted, real-time support from the MCC would be impossible, so “all of the current oversight and monitoring tasks that the MCC traditionally performs during an EVA will have to be handled autonomously or done by the IV crew member.” It is important to note that this statement touches on what is today a critical unknown: Can one or two astronauts handle IV support for Martian surface EVAs, given the total team size, in space and on the ground, that has historically been necessary to support LEO, cislunar, and lunar surface EVAs?

HEOT also noted the clear need to develop new technologies to allow “more capable onboard monitoring and analysis.” And because of the debilitating effects of the trip to and from Mars “the majority of the manual flying tasks for Mars and Earth entry will be automated, with the capability for manual controls as a backup only.” But the team seemed to present a split decision about the impact of distance on the crew’s task burden. On the one hand, they said, automation had the potential to reduce the astronauts’ ongoing workload. On the other hand, they acknowledged, there would be “an increased need for the crew to be able to perform a variety of in-situ repairs and maintenance tasks” compared to past spaceflight experience. Nevertheless, HEOT concluded that taken together, these factors “generally support having exploration missions with smaller, or at least comparable crews than have been typically used in LEO” and that a crew of four would be “operationally sufficient.”

As an additional argument for reducing crew size, Griffith’s team challenged the 1997 DRM’s minimum requirement that each person be able to back up just one specialty in addition to their own primary role. “It goes without saying,” they wrote, “that each crew member, while specializing in one area of expertise, must be competent in the other major areas, so that each of the crew members can provide effective backup to critical skills required of the entire crew in general.” Their document listed the following roles for the mission’s four astronauts:

1. “Mission commander and vehicle systems specialist/engineer. Responsible for overall onboard operations, safety and mission success. Expert in the vehicle systems, redundancy management and crew support of mission requirements. Will provide backup to the technical specialist for IFM [in-flight maintenance] tasks and troubleshooting.”
2. “Medical doctor. Self-explanatory for long duration missions. At least EMT-level training will be likely for all crew members as a backup. Biology background will also backup the science crew.”

3. “Geologist/Biologist/Meteorologist/Planetary Scientist. While each crew member will be trained and proficient in geology, at least one member should be a professionally trained geologist, experienced in ‘expedition’ research. This capability will be leveraged to help ground planners choose exploration targets and priorities. Heavy emphasis on biology and meteorology will be necessary to assist with mission/science planning and as a backup to the medical doctor.”
4. “Technical specialist/assistant geologist. This person would be an expert at IFM [in-flight maintenance] tasks, troubleshooting problems, and fabricating parts, while also having a substantial geology background. This will provide backup to both the systems expertise of the mission commander and the exploration background of the planetary scientist.”

A four-person crew capable of handling this broad spectrum of primary roles and backup duties, HEOT wrote, would need to be carefully selected “based on past training and/or professional experience.” The team added that although an odd-numbered crew was preferred for establishing a pyramidal command structure, screening the astronauts for compatibility would offset this disadvantage.

“It is shown,” they concluded, “that this reduction [from six to four] is consistent with past LEO experience and does not incur a substantial increase in exploration/EVA risk to the crews, whether they are assuming EV or IV duties.” The benefits of this smaller crew size included smaller vehicles, lower pressurized volume (“at least 180 cubic meters [would be saved] using current planning”), reduced life-support infrastructure, and a lessened demand for in-situ resources during the Mars surface portion of the mission.

#### ***A Dissenting View of HEOT Crew Size Recommendation***

It didn’t surprise Tony Griffith that his team’s crew-size recommendation might elicit pushback from some quarters. “We knew in writing this,” he recalls, “that we were kind of bucking the system, so to speak, in the sense that the DRM [crew size] was six. And what we wanted to show was that from an operational perspective, the logic existed to support a number smaller than that.” Griffith also acknowledges what he calls “the creative tension” that can exist between two groups with differing perspectives such as MOD as opposed to the engineers and architects who had traditionally led humans-to-Mars studies.

That tension was felt by a member of Griffith’s own team, Steve Hoffman, who had helped lead the creation of the 1997 DRM. Hoffman was uneasy about MOD’s conclusion that four crew was “operationally sufficient” because, he explains, “the unstated ‘part two’ of that statement was, ‘if everything goes right.’” The likelihood that at least one crewmember would become incapacitated due to injury or illness was one aspect that worried him; there was also the sheer duration of the mission, and the fact that unlike the previous LEO missions that HEOT used as the foundation for their crew size assessment, a Mars crew would have few opportunities to abort the mission and return to Earth in an emergency. Hoffman recalls that his colleagues in JSC’s Exploration Office, some of whom had been studying Mars missions almost as long as he had, shared his concerns. But one of the challenges of resolving the “creative tension” he felt with his data-oriented teammates from MOD, Hoffman says, is the fact that “those of us who had been working on this kind of mission could...only bring a lot of qualitative justification for our point of view, but we didn’t have a lot of quantitative evidence to go with it.” (It is worth noting that the HEOT assessment also did not include numerical data, other than the sizes of past LEO crews.)

Nevertheless, Hoffman and other like-minded mission planners were able to help spur the inclusion of several caveats in the finished document:

- On risk to mission success: “It should be noted that while a reduction to 4 crew members appears operationally sufficient, it may not be optimal for mission success. For instance, the assumptions outlined above do not presuppose the ability to sustain the incapacitation of a single crew member for a prolonged period of time. Probabilistic risk analysis has shown that for the duration of the proposed mission, at least one crew member will sustain a serious injury or illness. Despite an attempt at redundant crew training, depending on the affected crew member, the level of either scientific return or vehicle/systems capability may be reduced; thus affecting overall mission success.”
- On crew roles: “The areas of expertise outlined above are fairly ambitious. For example, a high level of in-depth knowledge, spread across several, unrelated scientific fields will likely be required of the mission’s Planetary Scientist. While it is possible for one crew member to have a working level knowledge of several scientific disciplines, the in-depth knowledge required for successful planetary exploration may make it more prudent to have an additional, dedicated crew member for this task.”
- On scenarios resulting in no IV support: “The above proposal also identifies two EVA teams of two crew members each. For scenarios where a remote EVA is in progress during the same timeframe as a local EVA is required for vehicle or system’s [sic] maintenance, there are no crew members left to perform the required IV tasks for either EVA team. The same situation results for contingency EVA rescue operations.”
- On the need for further risk analysis of crew size: “A crew size of 4 is considered operationally sufficient. However, to realistically determine the crew size, a trade must be made between the cost associated with one additional crew member and the level of risk which is considered acceptable for achieving mission success.”

Hoffman’s experience on the HEOT study motivated him to find ways of illuminating the crucial differences between Mars missions and past human spaceflight experience. One was by studying Mars mission analogs in extreme environments. Beginning in 1998 he’d been trekking to Devon Island in the Canadian arctic to support simulated Mars surface missions there and had discovered a degree of isolation that he says, “has to be experienced to be understood.” And in 2001 he organized a workshop in which Antarctic explorers whose expeditions dated back as far as the late 1940s came to JSC to share their perspectives on a range of issues, including crew size and dynamics. As a result of these activities, he realized that “a Mars mission is more than just Apollo on steroids; there is a quantum difference from any of our previous spaceflight experience.” In Hoffman’s mind, that reality drove the need to consider deeper issues that might outweigh the mass and cost savings resulting from MOD’s reduced crew size.

In 2001, a year after the release of HEOT’s revised *Operations Concept Definition*, NASA published *The Mars Surface Reference Mission: A Description of Human and Robotic Surface Activities*, which had been spearheaded and edited by Hoffman as a way of filling in the hole left by the 1997 DRM about tasks the astronauts would have to accomplish on the Martian surface. Looking back, Hoffman says he had hoped the document would provide the impetus for the quantitative analysis whose value was becoming increasingly evident, but that did not come to pass.

### 2005-2009: Six Crew Endures

Year	Title	NASA Originator	Crew (total)	Crew (landed)
2005	<i>Exploration Systems Architecture Study</i>	NASA Headquarters	6	?
2009	<i>Design Reference Architecture 5.0</i>	Mars Architecture Steering Group, NASA Headquarters	6	6

By mid-2005, NASA was responding to the direction given at the beginning of the previous year by President George W. Bush in his Vision for Space Exploration (VSE), which included laying the groundwork for human Mars missions. In November NASA released the *Exploration Systems Architecture Study* (ESAS), a 90-day effort to define the systems necessary to carry out the VSE's objectives in a new program called Constellation. ESAS called for development of a Crew Exploration Vehicle, later called the Orion Multipurpose Crew Vehicle (MPCV), that would be capable of transporting six people to and from the ISS and, ultimately, a Mars Transfer Vehicle—a crew size that reflected the recommendation of the 1997 DRM.

When NASA released a revised version of the reference mission in 2009 entitled *Human Exploration of Mars: Design Reference Architecture 5.0*, it again specified a six-person crew for Mars missions. “The rationale for a crew of this size,” the authors wrote, “has been judged to be a reasonable compromise between the skill mix and level of effort for missions of this complexity and duration balanced with the magnitude of the systems and infrastructure needed to support this crew.”

But a lengthy addendum to DRA 5.0 revealed an emerging sense of uncertainty about crew size. The addendum reprinted both the 1997 DRM's six-crew finding and the 1999-2000 HEOT four-crew assessment and then noted, “While no final conclusion has been reached regarding the required number of crew, recent studies have tended to assume a crew of six.” It added that “The specific skill mix for this crew also continues to be analyzed and will be dependent on needs driven by the objectives that are set for this crew.”

### 2010-2011: Preserving a Six-crew Option for Orion MPCV, under the Radar

In late 2010 and early 2011, more than a year after the publication of DRA 5.0, work was underway at NASA Headquarters to define Level I requirements for the Orion MPCV crew capsule that had replaced Constellation's Crew Exploration Vehicle. Doug Cooke, Associate Administrator for the Exploration Systems Mission Directorate, was working closely with his deputy, Dan Dumbacher, and during their deliberations they got into a discussion of crew size: Should it be kept at the six-crew recommended by the Design Reference Architecture? Or should it be reduced to four-crew, a number considered sufficient for ISS and lunar missions? They were acutely aware that the Level I requirements would establish the capsule's outer mold line, which could not be changed. There was a move to go with four crew, Dumbacher remembers, “because of cost.” But when it came time for a decision, he says, Cooke pushed back on that idea. “I can remember the meeting where Doug did it,” he recalls, “where we were thinking four, and Doug said, ‘No, we want to make sure that we have the outer mold line so that we can size up to six if we ever do that [i.e., send humans to Mars].’” But they kept it to themselves. To this



day, Dumbacher says, “I am confident that this is not written down anywhere in memos and you're not going to be able to find it documented.”

“We set the public requirement as four because we had rationale for that,” namely the lunar missions that were on a nearer horizon than humans-to-Mars. “We sized the outer mold line for the vehicle for six so that we could increase the crew compliment if and when we got down there. But we just never told anybody that that's what we were doing.” The reason, Dumbacher says, boiled down to politics. “We knew at the political level that four was a sellable number. So we stuck with four, it went in the requirements that way, and we just kept on trucking.” Dumbacher’s comments provide a window on the ways in which engineering decisions at the highest level can be shaped by political realities.

**2014-2016: Four Crew is Specified, Despite Opposition**

Year	Title	NASA Originator	Crew (total)	Crew (landed)
2014-2016	<i>The Evolvable Mars Campaign</i>	Human Exploration and Operations Mission Directorate	4	4 (TBR)

The cancellation of Constellation in February 2010 put an end to the formal development of the Design Reference Architecture. In 2014 NASA’s Human Exploration and Operations Mission Directorate (HEOMD) chose a new direction for humans-to-Mars planning called the Evolvable Mars Campaign (EMC). As one 2015 paper noted, “[t]he EMC is not a specific plan for conducting missions beyond LEO and eventually to Mars,” but rather, “a framework for defining the pioneering strategy for extending human access and operational capabilities in the journey towards the Mars system in the mid-2030s, while laying the foundation for sustained human presence in the following decades.” The EMC was designed to leverage the Capability Driven Framework (CDF), HEOMD’s plan for near-term human and robotic missions that would incrementally build toward “affordable flight elements” for a range of deep-space missions.

“Humans will travel to the Mars system by [the] mid-2030s,” stated a late-2016 NASA presentation on the work of the EMC team, which included members from across the Agency. Astronauts would leave on a mission to the Martian moon Phobos in 2033, followed in 2039 by the first Mars landing. One of the ground rules given to the team, the authors noted, was a four-person crew.<sup>6</sup>

Steve Hoffman, who took part in the new study, recalls that he and fellow EMC team member Larry Toups were not comfortable with the direction to use a crew size of four and voiced their concerns. “Larry and I objected, others objected,” Hoffman says, “but the Headquarters folks that were directing us said, ‘Well, let's just see what happens. Let's see if we can make it work [with four crew].’” No additional explanation was ever provided to Hoffman or Toups. In addition, a 2015 paper whose lead authors were EMC team members Kandyce Goodliff and William Cirillo contained words of caution on the risk to mission success posed by small crew sizes due to the amount of time required for maintenance. “With limited abort options,” they wrote, “the ability to maintain systems will be critical. There is potential that repair activities

<sup>6</sup> Some EMC team members recall that follow-on studies with six crew were intended but ultimately were not undertaken.

could overwhelm available crew time.” Nevertheless, with the Evolvable Mars Campaign the six-crew standard that had held since 1997 was overturned. It is certainly plausible that in the EMC timeframe planners believed, as Dan Dumbacher did in 2011, that any number higher than four would not be politically viable.

**2021: A split-crew Approach for the First Mars Landing Mission**

Year	Title	NASA Originator	Crew (total)	Crew (landed)
2021	<i>Strategic Analysis Cycle 2021</i>	Mars Architecture Team	4	2

In 2021, six decades after the Lewis Research Center (now the Glenn Research Center) published NASA’s first Mars mission study in 1961, human expeditions to the Red Planet remained what planners called “a horizon goal,” one that lacked formal approval but still attracted the energies and intellects of specialists from across NASA. By that year the Agency had reorganized those experts into the MAT, which was initially tasked with devising a plan for accomplishing the first Mars landing mission “as fast—and as soon—as practical.” That meant abandoning the options favored in previous studies that minimized energy requirements but resulted in stays on the Martian surface of one Earth year or more and total mission durations of three years or more. Instead, the MAT zeroed in on options with durations of less than three years that include one-month surface stays.<sup>7</sup> They also focused on ways to reduce mass by designing a mission that required as little infrastructure as possible. The study’s purpose, as team members wrote in 2022, was to “fill in an often-overlooked corner of the trade space, helping to complete the menu of options available to decision-makers as they chart the course for humans to Mars.”

One key to the MAT’s mission design was splitting its four-person crew into two pairs, one of whom would land on the surface in a pressurized rover while the other remained in the Transit Habitat in Mars orbit. By having the surface crew live in their pressurized rover during their relatively short stay on the planet, the MAT eliminated the need for a surface habitat on this first landing mission. The pair would conduct a series of EVAs ranging perhaps as far as 20 kilometers from their landing point, utilizing a pre-deployed fission power generator at the landing site to recharge the rover’s batteries.

Meanwhile, their crewmates in Mars orbit would be responsible for an array of roles including supporting the surface crew during EVAs, providing a communications relay for them with Earth, and potentially, teleoperating robotic assets at the landing site and participating in analyzing data and planning future activities in coordination with experts back home. All of this, of course, would be in addition to whatever tasks were necessary to operate and maintain their orbiting habitat by themselves until their crewmates returned from the surface in a previously deployed and fueled Mars Ascent Vehicle.

---

<sup>7</sup> One of the main goals of the shorter mission was reducing the risk to crew health, but the MAT acknowledged that their plan had pluses and minuses. The reduced total mission duration, they wrote, meant “less time for equipment to break down or for crew to develop health issues.” But the chosen scenario actually required more time spent in transit compared to longer-duration missions that included year-long surface stays. As a result, the authors noted, the crew could face increased risk from exposure to microgravity and deep-space radiation.

Despite many daunting challenges, including development of a Deep Space Transport utilizing nuclear-electric propulsion, the study concluded that “shorter round-trip Mars missions are certainly possible from a performance standpoint.” But a critical question regarding the *human* performance requirements of the mission remains to be addressed: Is the ambitious agenda described above feasible for the specified crew size?

That question cannot be answered only by past spaceflight experience; it must be addressed with quantitative analysis of crew workload and expertise that would actually be required.

### ***Additional Concerns and Unknowns***

On a broader level, a number of concerns and unknowns for human Mars, missions have been identified by those interviewed for this historical narrative that can be addressed using NESC’s new analytical capability.

- Without detailed definition of the Mars transit habitat, key unknowns exist about the knowledge base and workload required for onboard maintenance and repair. These unknowns also limit the ability to estimate pre-mission training requirements, another important factor in determining the adequacy of any given crew size. The only current basis for comparison is the ISS, but that is challenging given the station’s level of real-time troubleshooting support from MCC that would be unavailable on a Mars mission. The analytical capability being developed by the NESC can help guide designers to create a transit habitat whose operation and maintenance requirements would not overtax the crew. In addition, the NESC has laid out a systematic approach to estimating pre-mission training requirements with an analytical model.
- ISS experience shows that there are real limits to the amount of information that the crew can be expected to retain during a multi-year mission. This directly impacts the adequacy of any given crew size, and points to the need for onboard information and diagnostic capabilities to assist the crew. There are also limits to the number of systems any single ISS flight controller can realistically be trained to master. The NESC capability includes modeling of the expertise required to meet primary mission objectives.
- Past experience in Apollo and ISS missions shows that a Mars crew is likely to encounter problems that fall outside the scope of established procedures, meaning that the astronauts would not have information onboard to find solutions. This can become critical for serious problems whose time-to-effect requires the Mars crew to respond independently from the MCC given the communications delay/blackout with Earth. The NESC capability addresses the onboard expertise necessary to respond to these unforeseen failures.
- The workload of the crew that remains in Mars orbit during the surface stay, including remote IV support tasks for all surface EVAs, will be one of the most important drivers for determining the total crew size. It must be recognized that EVA support on ISS and all other previous human spaceflight missions has always included many more people than the front-room flight controller, who relies on input from a network of back-room specialists to address unexpected anomalies and problems. The workload of the crew in Mars orbit can be addressed using an NESC analytical model.
- Determining the cadence of surface EVAs with the goal of obtaining high-quality science will need to consider not only the workload of the EV astronauts, but those providing IV

support. The level of effort that can be sustained by the IV crew, who will have to handle the operation and maintenance of their vehicle in addition to their IV workload, all without real-time support from Earth, is a key unknown that has important implications for determining a crew size adequate for mission success. The NESC has identified this unknown as an area for future work.

### ***Summing up***

Almost from the very beginning of Mars mission studies, there has been an awareness that in order to determine the necessary crew size planners must consider the astronauts' roles and tasks, and the need for cross-training to provide backup in case of contingencies, as critical factors. Although much progress has been made over the decades in assessing these factors, it is only now that quantitative methods of analyzing the impact of crew size on crew safety and mission success are becoming available with the NESC's new capability. While this capability fills a crucial gap, it is not a turnkey solution. It is intended to guide decision-makers, not provide "the answer."

How many people should NASA send to Mars? Finding the sweet spot between "too many to be doable" and "too few to enable crew survival and mission success" will always be a judgment call based on rigorous, clear-eyed assessments. But if there is one lesson to be learned from the work of all the brilliant minds who have faced the ultimate systems challenge over the last 75 years, it is that the human exploration of Mars is an Everest for our species, and we must never let ourselves be lured into underestimating the extraordinary and unprecedented demands of reaching the summit.

### **6.2.2 Crew Size Determination within the DoD**

In addition to considering NASA's historical consideration of crew size for missions to Mars, the assessment team turned to the NPS to understand how the military considers crew size. In support of the assessment, two NPS graduate students conducted literature reviews and structured interviews on DoD policies and guidance for determining crew size [ref. 2]. A summary of their paper is provided:

The National Aeronautics and Space Administration (NASA) is pursuing the task of creating a methodology for crew size determination with applications to human Mars missions. The authors of "A Review of Department of Defense (DoD) Manpower Analyses to Inform Crew Size Determination for NASA's Manned Missions to Mars," Amanda F. Lippert and Benjamin L. Scripture, conducted a review of the literature published by the Department of Defense (DoD) on crew size determination, task analysis, and workload assessment. This review aimed to compile the published research on the topic while identifying gaps in the research that can be filled.

Although the original intent of the review was to further the authors' understanding of how crew sizes have historically been determined by examining current DoD guidance on Manpower analyses, the authors discovered that there is little published literature that details how previous DoD Programs determined their optimum crew size in the early stages of the program. Instead, they found that Human System Integration (HSI) practices are often absent from early stages of program development. However, some guidance exists in the DoD and individual branches of the Armed Forces on how to incorporate HSI practices into acquisition programs.

The review consisted of literature from the DoD, Navy, Army, and Air Force to determine which HSI practices exist and where there are gaps that need to be filled by further research, publications, and policies.

The authors recognize that guidelines from the DoD and branches of the Armed Forces may differ from the needs of NASA's crew size determination; the DoD and military rely on historical data to create their systems, whereas NASA has limited historical data to draw upon for this type of unprecedented mission. However, they believe that some of the methodologies, protocols, and procedures used by the aforementioned entities may be beneficial for the NASA team to review as they endeavor to create a methodology for crew size determination.

Although the DoD does not offer specific guidance for Manpower requirements determination (MRD), they emphasize utilizing data and quantifiable metrics to evaluate and determine workload. In addition, they direct acquisition program managers to collaborate with Manpower experts. The authors found that DoD literature (e.g., the Defense Acquisition Guidebook) offers guidelines to ensure that programs conduct a comprehensive analysis of Manpower but do not provide explicit procedures for crew size determination [ref. 10].

The authors reviewed the OPNAVINST 1000.16L: Navy Total Force Manpower Policies and Procedures [ref. 11]. This document provides general guidance for MRD and approval, including how to report Manpower requirements for funding. It also emphasizes that fiscal restraints can limit the approval of those requirements. Although the authors found little in the document relating to crew size determination, they believe that it could be beneficial to consider the way that the Navy defines Manpower Requirements. Through their definition, the Navy affirms that conducting task and workload analysis is needed to determine the workload assigned to individual crewmembers.

In the OPNAVINST 1000.16L, the authors found the methodology used for Fleet MRD to be the most comparable to that of a NASA Spacecraft because it considers the required operation capabilities (ROC) as well as the projected operational environment (POE). This methodology maintains that ROC and POE are crucial aspects of fleet Manpower determination and recognizes that Manpower requirements need to be adapted to fit mission requirements and environmental limitations. The authors could not locate detailed instructions in the publication but found some descriptions of elements of MRD (e.g., ROC and POE parameters and analysis, directed Manpower requirements, operational manning, planned maintenance, corrective maintenance, facilities maintenance, utility tasking, administrative support, support actions, and workload allowances). The authors provide brief descriptions of each element in their paper.

The authors noted that the Navy Total Force Manpower Requirements Handbook is the only Navy-published document they could find that provides step-by-step and practical instruction for Manpower analysis [ref. 12]. They broke down the document into the following chapters, noting the methods and tools indicated in the chapter titles, "The Five Steps to Performing a Study," "Performance Work Statement and Workload Indicator Development," "Staffing Standards and Manpower Estimating Models," "General Work Measurement and Methods Study Tools and Techniques," "Operational Audit; Work Sampling; Timing Technique," "Work Distribution Analysis," "Operational Analysis," and "Benchmarking." They believe the NASA team working on crew size determination could review this framework as they create a methodology.

In their examination of Army Regulation 570-4: Manpower Management, the authors found that it gave greater detail on MRD methodologies than some of the other Armed Forces literature [ref. 13] In this document, “Emphasis is placed on study of workload requirements through quantitative processes based on historical data...” (Lippert & Scripture, 2021). They define workload by the amount of work that needs to be completed and the resources necessary to fulfill that work. While MRD processes and techniques can vary, the authors found that they share a common framework; Create a Baseline, Validate Mission, Evaluate Functions, Validate Manpower Utilization, Define, Validate, and Project Workload, Develop Workload/Manpower Relationship, Discuss Issues, Assumptions, and Risks, Compute Manpower Demand, Determine Optimum Manpower Mix, Structure New Organization, Resolve Remaining Issues, and Document Results. The authors expand on each point of the framework in their paper.

The Army uses Manpower staffing guides to determine the number and type of people needed to fulfill work requirements for specific types of units. When there are no precedents or standards, Manpower studies are conducted to evaluate the workload to determine the Manpower requirement.

In their review of Air Force literature, the authors found that Air Force Instruction 38-101: Manpower and Organization serves as the primary document for the Air Force’s Manpower management [ref. 14]. This document, while not detailed on processes for MRD, defines the availability factors used by the Air Force; these factors are defined as the “average number of man-hours per month an individual is available for primary duties” (Lippert & Scripture, 2021).

The authors regarded the Air Force Manual 38-102: Manpower and Organization; Standard Work Processes and Procedures (AFMAN 38-102) as the most detailed publication they reviewed related to conducting MRD. This publication “provides the framework for developing the Manpower determinants that form the basis of the Air Force’s Manpower plan” (Lippert & Scripture, 2021). The AFMAN 38-102 provides a detailed analysis of tools used by Manpower analysts, a list of which the authors summarize in their paper. This publication includes instructions and guidelines for a comprehensive list of Manpower and task analysis techniques [ref. 15]

By listing the following chapters and providing concise descriptions of the chapter, found in their paper, the authors believe one can grasp the extent of the information contained within the manual; “Work Measurement,” “Operational Audits,” “Workshop Measurement and Facilitation Techniques,” “Time Study,” “Determining Personal, Fatigue, and Delay Allowances,” “Work Sampling,” “Queueing,” “Simulation Modeling,” “Minimum Manpower, Standby Determination, and Man-Hour Shift Profile Analysis,” “Manpower Model Development and Selections Using Correlation and Regression Analysis,” “Core modeling,” and “Modular Equations.” The authors note that although there is no distinct methodology for crew size determination, numerous tools and methodologies detailed in the document could be valuable in that endeavor.

The authors believe that the most valuable information and knowledge pertaining to HSI practices is not formally published but instead comes from “informal networking channels.” To capture and publish some of this knowledge, they conducted interviews with HSI experts.

In their interview with Dr. Jim Pharmer, he highlighted the emphasis current DoD acquisition programs put on the completion of a system under budget and on time rather than on sustainment, which is ultimately the highest cost driver. Dr. Pharmer worked on DDG 1000 program in which HSI practices were integrated early, praising the program for including a Manpower Key Performance Parameter (KPP). He noted the use of the Manpower Uncertainties Issues List (MUIL) that gave the team a space to bring attention to issues or concerns regarding an HSI domain; this tool brought HSI concerns to the program manager's attention so that solutions could be proposed, and those challenges could be addressed early.

Mr. Doyle Avant shared, in their interview, that the Office of Naval Research funded outside research to determine what they should use as the Productive Availability Factor (PAF) when conducting validation calculations for Manpower analysis. The PAF serves as the denominator for the Manpower formula used to determine the number of Manpower billets needed to complete the work. Mr. Avant believes that validating manpower requirements is crucial to ensure that the defined work that needs to be done is accurate.

The authors identified several themes during their interview with Dr. Pam Savage-Knepshield. Dr. Savage-Knepshield spent much of her career working in the commercial industry, bringing a different perspective and valuable knowledge about how to make systems more intuitive to the DoD. Unlike many HSI practitioners, Dr. Savage-Knepshield holds a permanent position that allows her to influence programs and have important conversations with PMs on HSI integration. Finally, the authors gained insight into what Dr. Savage-Knepshield called "Soldier Touchpoints." For these surveys to have academic rigor, and therefore be useful, she recommends the Army hire HSI professionals to conduct these surveys and perform analysis of the data.

### *The Littoral Combat Ships: A Cautionary Tale*

While the military has established methodologies, protocols, and procedures for manpower determination, there is a cautionary tale within the DoD that has important lessons that NASA can learn. In the early aughts, the military commissioned two classes of Littoral Combat Ships (LCS). The LCS was intended to allow the military to reduce the number of sailors from ~200 sailors on similar ships to ~45 sailors on the LCS based on the expectation that smart technologies would support the planned reduction. After the first ships were put to sea, there were several incidents including mechanical failures and the ships proved difficult for sailors to control. The LCS has been so unsuccessful that the military has begun decommissioning ships. The Naval Postgraduate School conducted multiple human performance modeling studies on the ship's manpower needs after the ships had entered service and found that the LCS required ~60 sailors to safely operate the ships, many more than planned, and required sailors with significantly more experience than is normally required on similar ships (sailors ranked E5, having an average of 30 years old) [refs. 16, 17].



*Figure 4. Littoral Combat Ship*

The lesson learned for NASA’s decision-makers on crew size is that mandating a crew size for a new ship without understanding the workload and necessary expertise within the crew to successfully operate the ship may lead to serious consequences.

**F-1.** Deterministically mandating a Mars mission crew size without consideration of crew workload and expertise increases risk to loss of crew/loss of mission and mission success.

### **6.2.3 Background Summary**

Like the DoD, NASA has processes for using workload measures (of individuals) in the design and development of vehicles and operations. The NASA Task Load Index (NASA-TLX) developed by ARC as a tool for cognitive workload rating is one of the most recognized workload measures in human factors research. However, while the DoD and NASA have established qualitative and validated workload and human performance models, neither organization utilizes their models in trade space decision-making for determining crew sizes for mission operations.

Missions to Mars will differ from all previous human spaceflight missions in that the crew will be required to operate semi-autonomously to autonomously from the MCC teams. Without a systematic, repeatable process to determine the number and composition of crew necessary to successfully accomplish these missions prior to launching, NASA increases the risk to such missions in that crew sizes may be too small to meet mission objectives under nominal conditions and, more consequentially, the crewmembers may not have the expertise needed to successfully respond to failures without the real-time expertise in the MCC on which NASA has always relied.

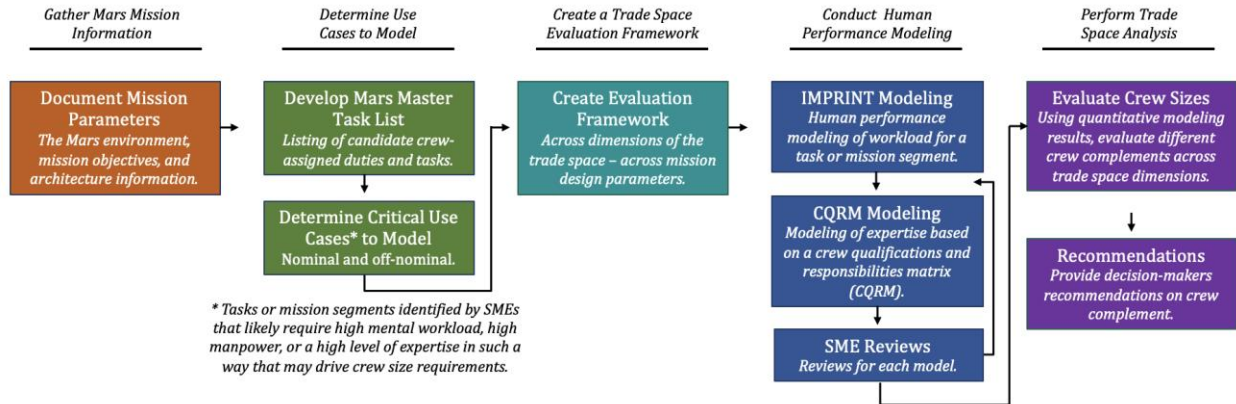


**F-2.** While DoD and NASA have established qualitative and validated workload and human performance models, neither organization has utilized their models in trade space decision-making for determining crew sizes for mission operations.

In further review of the literature, the assessment team found there was a team developing a methodology for tradeoffs in crew size determination for future DoD missions. In their work, the DoD-funded team approached the problem by recognizing that determining crew size is a “form of function allocation” [ref. 3] where mission functions are allocated across the humans and automation with the focus is on “the number of human operators necessary for a safe and successful mission” [ref. 4]. The DoD-funded team developed a methodology for considering trades in crew size given the allocation of functions between the human operators and automation using human performance modeling to consider the workload on the human operators. The team developed a framework for evaluating tradeoffs based on model outputs recognizing that there is not a best allocation of functions nor is there a best crew size, rather there are tradeoffs in factors (e.g., cost, risk, and mission success).

### 6.3 Proposed Solution

To fill the gap in the Agency’s capability for determining crew size for missions to Mars, the proposed solution is a methodology for NASA to perform systematic, repeatable trade space analysis comparing crew size for missions to Mars against trade space parameters using quantitative data from human performance modeling.



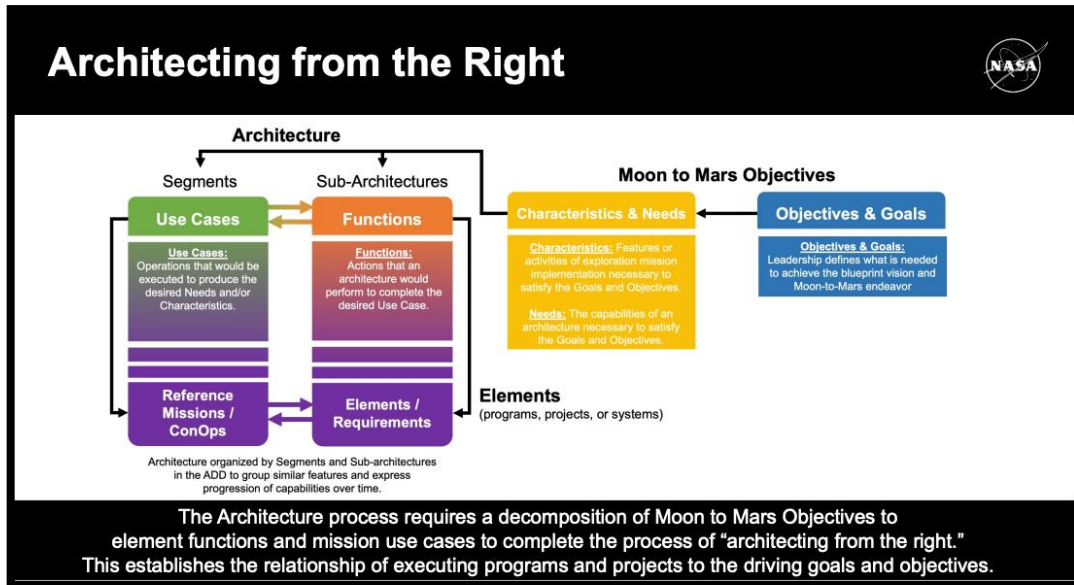
**Figure 5. Proposed Solution**

The steps in the methodology are (Figure 5):

- Gather Mars Mission Information
- Determine Use Cases to Model
- Create a Trade Space Evaluation Framework
- Conduct Human Performance Modeling
- Perform Trade Space Analyses

The results of the analyses can be used to make recommendations to decision-makers as they consider the potentially competing factors in deciding on the crew size for missions to Mars.

Several steps clearly align with NASA’s Strategic Architecture Office strategy for architecting from the right: defining the Mars mission objectives, determining the architecture required to support those objectives, and then identifying operational use cases to meet mission needs (Figure 6).



*Figure 6. Architecting From the Right [ref. 18]*

The assessment team developed the full methodology for trade space analysis using human performance modeling based on work conducted for the DoD on determining crew size for a set of military missions and on recommendations from the NPS review of DOD manpower determinations. Each of the steps in the methodology are described in more detail below.

### 6.3.1 Gather Mars Mission Information

Gathering information on the Mars mission environment, on NASA’s mission objectives and science goals, and on the anticipated Mars mission architecture is “intended to provide the necessary contextual knowledge about the future environment” [ref. 19] needed to build human performance models. In their work for the DOD, Militello et al. (2018) define this set of information as describing the “envisioned world” or “future operating environment” [ref. 19]. The assessment team decided to separate this information for this report, to align steps within the methodology to the Agency’s current Moon-to-Mars architecting.

#### *Mars Mission Environment*

The Mars mission environment includes a description of the spaceflight and planetary surface environment, including hazards within the environment and supporting communication infrastructure.

*Deep Space and Planetary Surface.* Astronauts on missions to Mars will operate in a deep space microgravity environment on the transit to and from Mars and in a reduced gravity environment

on the Mars planetary surface. These environments are hostile to life and include inherent hazards described below.

*Spaceflight Hazards.* NASA's HSRB<sup>8</sup> recognized that there are "unchangeable aspects of the space environment" that pose a risk to crew [ref. 5]. The five main hazards of the spaceflight environment harmful to humans are identified as:

1. *"Altered gravity – Exposure to a gravity environment that is less than Earth-normal begins a process of adaptation; some of these adaptations create issues for human bodies that developed to function in a 1G (gravity) environment.*
2. *Radiation – Risk exposure damages biological cells in duration- and intensity-dependent manner and may lead to clinical illness or contribute to human performance decrements.*
3. *Isolation and Confinement – Increasing time in isolation increases the risk of psychological, physical, and mental health issues for crew.*
4. *Hostile closed environment – The habitable volume and environmental systems required to enable life and work in any space vehicle or habitat can expose astronauts to different atmospheric, water, or microbial challenges as well as acceleration environments that can lead to injury.*
5. *Distance from Earth – Impacts real-time communications, consumables resupply, time to evacuation, and available mass and volume that can limit inclusion of countermeasures."* [ref. 14]

While all five hazards may impact crew (e.g., radiation may affect cognitive functioning leading to performance decrements, isolation and confinement may impact psychological health or team cohesion, a hostile closed environment may lead to injuries – all of which may impact crew performance and thus impact crew size), modeling efforts for most of the models for this assessment assume a healthy, highly functioning team. The one exception is that medical events are included in the Mars Transit Crew model. Future modeling efforts should consider the additional effects that these hazards have on crew performance and manpower and the impact that may have on crew size.

*Communication Infrastructure.* Missions to Mars will take astronauts further from Earth than any previous human spaceflight missions. Given the great distances, a crew at Mars will experience communication delays from ~4 minutes up to ~22 minutes one-way and one continuous period of communication blackout lasting ~2 to 3 weeks per mission during Mars superior conjunction (the actual communication delay profile will be highly dependent on the specific mission trajectory).[ref. 20] NASA's SCaN Program personnel provided information on the possibilities for the communication infrastructure to support communication among the crew in the Mars vicinity and between the Earth and Mars [ref. 21].

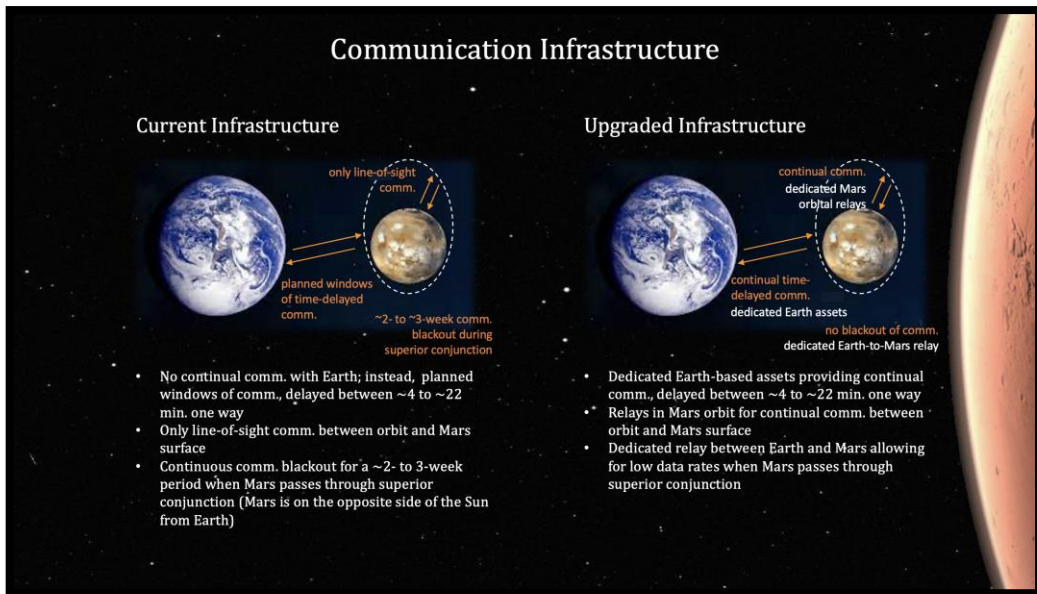
SCaN manages and directs the ground-based facilities and services provided by the Deep Space Network (DSN) and the Near Space Network (NSN), the networks that provide space-to-ground communication for NASA's human spaceflight and uncrewed science missions. ScaN is currently working to develop a more robust network for NASA's upcoming Artemis missions to cislunar space and the lunar surface designated LunaNet. [ref. 9] NASA's Planetary Science Division has a study underway to assess the communication infrastructure for human missions to

---

<sup>8</sup> HSRB operates as part of the Health and Medical Technical Authority (HMTA) within the Office of the Chief Health and Medical Officer (OCHMO) via the JSC Chief Medical Officer.

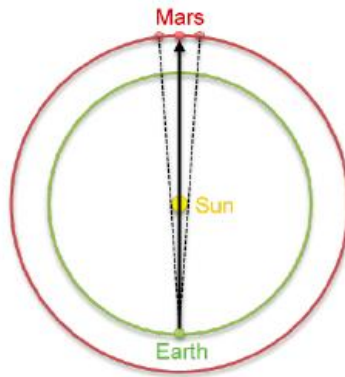
Mars. According to SCAN, such a Mars communication infrastructure may likely include an application of the LunaNet architecture to create a MarsNet that grows out of the current Mars Relay Network and includes contributions from international partners and uses Mars Relay & Navigation Orbiters to provide “local” (cis-Mars) service.

It is worth noting that the DSN does not currently enable continual communication with uncrewed science missions orbiting Mars or on the Martian surface. Instead, there are scheduled times throughout the day for communicating with each spacecraft or rover – e.g., a planned time for sending data and another time for receiving data. As shown in Figure 7, if there are not upgrades in place to the DSN for human Mars missions, the crew will not have continual communication with Earth. Instead, there would be planned windows of time for space-to-ground communications with Earth, delayed between ~4 to ~22 minutes one-way for a crew at Mars. Additionally, without Mars Relay & Navigation Orbiters used to augment local surface coverage, a crew on the planetary surface may only have sporadic communication with a crew in Mars orbit, when the on-orbit vehicle is in direct light-of-sight of the crew on the surface. Mars Relay & Navigation Orbiters may use crosslinks to enable continuous coverage of a surface region such as a Base Camp, and, hence, continuous communication with orbiting crew.



**Figure 7. Communication Infrastructure**

When Mars or the spacecraft passes through superior conjunction—that is, Mars or the spacecraft is on the opposite side of the Sun from Earth—there will be a period of time without direct line-of sight with Earth (Figure 8). (Mars superior conjunction occurs approximately every 25 months.) Since all communication with Mars is currently by line-of-sight, if there is not a dedicated relay between the orbits of the Earth and Mars to bounce a signal around the Sun, then there would be a continuous communication blackout between Earth and Mars for ~2 to 3 weeks (again noting that the communication profile will be highly dependent on the specific mission trajectory; for some mission profiles the conjunction blackout would occur during the transit to or from Mars). [ref. 20] Current Mars spacecraft are put into a near dormant state during this timeframe or loaded in advance with commands covering the blackout and operated autonomously; however, that is not an option for a human mission.



**Figure 8. Earth-Sun-Mars Conjunction**  
[ref. 15, Figure 1]

To provide time delayed communication during superior conjunction, a dedicated communications relay would need to be placed in an orbit that allows for low data rates in both directions providing minimal communication coverage between Earth and Mars (or the spacecraft), although the communication delay would likely be longer during Mars superior conjunction since the signal would need to travel further than line-of-sight distance [ref. 20].

In summary, for a crew at Mars to have continual time-delayed communication with Earth throughout their entire mission would require upgrades to the DSN, Mars Relay & Navigation Orbiters, and an Earth-to-Mars relay.

### ***Mars Mission Objectives and Goals***

The assessment team gathered Mars mission objectives and goals to add to the contextual information needed to build the models and provide information to support the trade space evaluation. As described in a later section, the evaluation framework includes evaluating the ability of different crew sizes to meet mission objectives.

The Agency published their most recent set of mission objectives and goals to Mars in their *Moon to Mars Objectives* publication dated September 2022 [ref. 6]. The objectives and goals include recurring tenets (RT) that are common themes across objectives, science objectives across disciplines including lunar/planetary science (LPS), human and biological science (HBS), and science enabling (SE) objectives, infrastructure objectives including Mars infrastructure (MI), transportation and habitation (TH) goals, and operations (OP) goals. The objectives most related to this assessment include:

- RT-3: Crew Return: return crews safely to Earth while mitigating adverse impacts to crew health.
- RT-4: Crew Time: maximize crew time available for science and engineering activities within planned mission durations.
- LPS-4<sup>M</sup>: Advance understanding of the origin of life in the solar system by identifying where and when potentially habitable environments exist(ed), what processes led to their formation, how planetary environments and habitable conditions have co-evolved over time, and whether there is evidence of past or present life in the solar system beyond Earth.

- HBS-2<sup>LM</sup>: Evaluate and validate progressively Earth-independent crew health and performance systems and operations with mission durations representative of Mars-class missions.
- SE-1<sup>LM</sup>: Provide in-depth, mission-specific science training for astronauts to enable crew to perform high-priority or transformational science on the surface of the Moon, and Mars, and in deep space.
- MI-2<sup>M</sup>: Develop Mars surface, orbital, and Mars-to-Earth communications to support an initial human Mars exploration campaign.
- TH-10<sup>M</sup>: Develop integrated human and robotic systems with inter-relationships that enable maximum science and exploration during Martian missions.
- OP-2<sup>LM</sup>: Optimize operations, training, and interaction between the team on Earth, crewmembers on orbit, and a Martian surface team considering communication delays, autonomy level, and time required for an early return to the Earth.
- OP-9<sup>LM</sup>: Demonstrate the capability of integrated robotic systems to support and maximize the useful work performed by crewmembers on the surface, and in orbit.

### ***Architecture Information***

To develop human performance models for trade space analysis for crew size for future missions (of any kind), a team requires a third set of contextual knowledge, that is information on the future mission architecture, including information on vehicle capabilities and technologies necessary to support crew operational task performance and operational and training data. However, that information is not always known. To address this limitation, the team must determine the best analog missions, analog vehicles, and analog programs of training to model and must determine any known or anticipated new capabilities to include in their models.

NASA has not defined the architecture for missions to Mars. While the findings, observations, and recommendations from this assessment can be used to inform decisions on the crew size and mission architecture that better supports the crew in achieving mission success, there may be limitations on the applicability of the findings if model assumptions prove to be very different from the final architecture. This is simply the reality of attempting such a challenging endeavor – that is, attempting to model missions that have not been designed to inform the necessary crew size and design of such missions.

With this in mind, the assessment team gathered information from the most relevant analog vehicles for Mars including ISS, MPCV, and Gateway Programs and operational and training information from FOD. The assessment team conducted literature reviews and interviewed SMEs to further gather architecture information, and the team documented assumptions on capabilities for each model in Section 7. For the one model that required a listing of vehicles in the architecture and for the listing of candidate crew tasks for Mars, the assessment team chose to reference the vehicles in the SAC22 architecture: an MPCV Earth-to-orbit vehicle, a Transit Habitat for the transit to and from Mars, a Mars Descent Vehicle (MDV), a Mars Rover, and a Mars Ascent Vehicle (MAV) [ref. 22]. As new technologies are brought online and as Mars functions and elements are defined, their impacts to crew workload should be incorporated in future modeling efforts.

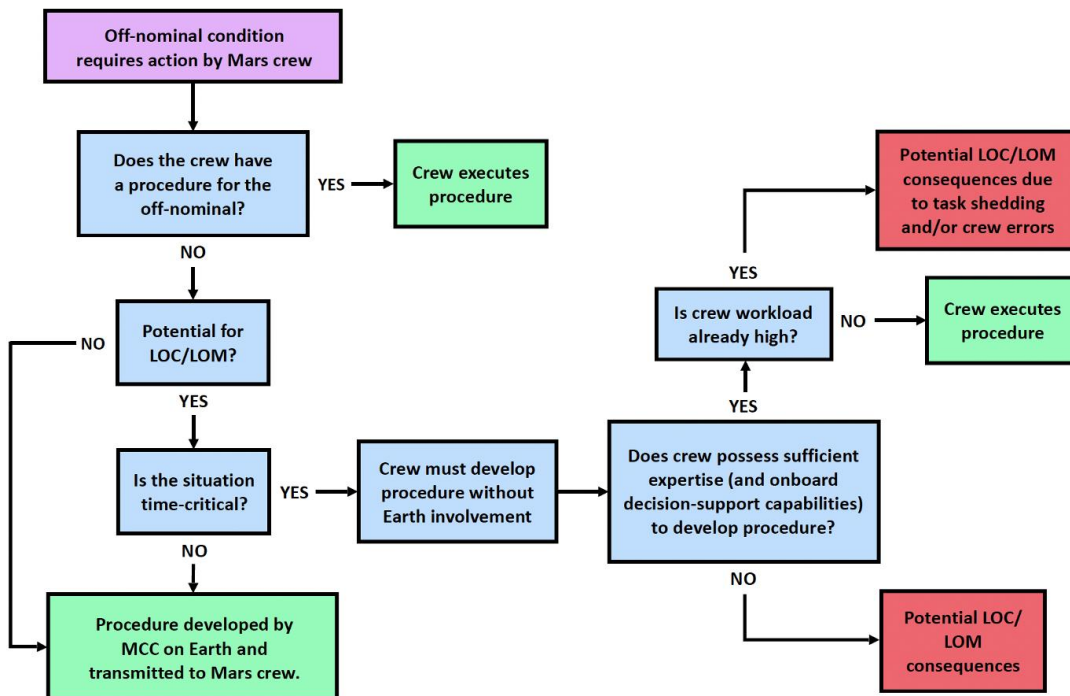
### **6.3.2 Determine Use Cases to Model**

After gathering information on the Mars mission environment, on NASA’s mission objectives and science goals, and on the anticipated Mars mission architecture, the next step in the



methodology is to consider the operational demands or workload of the crew to determine use cases to model. In conversations with HSI researchers at the NPS, the NPS researchers recommended that the assessment team focus not on use cases for nominal operations but also consider “corner cases” in the trade space, to look for those challenging scenarios that a crew would need to be able to respond to successfully complete their mission. The assessment team set criteria for candidate use cases to include use cases necessary to meet primary mission objectives and use cases to respond to unforeseen failures (i.e., for which pre-planned responses do not exist) with potential loss of crew/loss of mission consequences and short time-to-effect.

Despite the most thorough preparations and planning, off-nominal conditions are an inevitable aspect of human space flight. Many off-nominal events will have been anticipated and planned for. Crewmembers on a mission to Mars will have received training for these situations and will be able to refer to procedures to guide their actions. On other occasions however, off-nominals take anticipated forms, or occur in ways that were considered to be extremely unlikely during hazard analyses. As illustrated in Figure 9, crewmembers who are unable to receive real-time (or near real-time) support from the MCC will need the capacity to act autonomously and develop solutions, particularly in the case of off-nominal conditions that have a short time-to-effect and have the potential for loss of crew/loss of mission consequences. The assumption by the HSIA Risk team is that an unforeseen failure that must be safed within ~24 hours and up to ~72 hours would require the Mars crew to respond independently from the MCC given the communications delay/blackout with Earth. The assessment team assumed the MCC would be available to support less consequential failures or those with a longer time-to-effect.



Several factors, including crew size, determine whether a Mars crew can successfully respond to an off-nominal condition without real-time support from mission control.

**Figure 9. Crew Response to Off-Nominal Conditions**

The assessment team also set as criteria use cases that would that likely require high manpower, high mental workload, or a high level of expertise in such a way that may drive crew size requirements. The assessment team gathered candidate use cases based on previous work on ISS high-risk, critical skills (tasks and skills associated with emergencies, major malfunction, or time-critical responses), research on autonomous tasks for Mars (tasks that are critical to perform but will likely prove challenging to complete autonomously from the ground), and through SME interviews conducted by the assessment team [refs. 23, 24]. Candidate use cases, or modeling scenarios, included:

- Conduct nominal science operations on the transit to Mars.
- Perform robotic activities during the transit to Mars or in Mars orbit.
- Respond to an automation failure on the transit to Mars.
- Respond to an unforeseen major system failure on the transit to Mars.
- Conduct an EVA repair on transit to Mars.
- Prepare for Mars surface descent.
- Perform an installation/activation/inspection of vehicle/habitat system on Mars.
- Conduct a geological survey during planetary surface EVA.
- Perform a complex repair during planetary surface EVA.
- Support a planetary surface EVA (IV crew).
- Conduct a 30-day planetary surface stay, including accounting for a crewmember injury.
- Conduct planetary surface rover operations.
- Respond to loss of power to an important science experiment on Mars.
- Prepare for Mars ascent.
- Perform a job analysis of duties across the crew.

The assessment team created criteria against which to down-select the use cases to build for the first set of models for trade space analysis. The criteria included the following questions:

- Criteria 1: Nominal, Off-Nominal, Emergency
  - Does this use case include nominal operations, off-nominal operations, or emergency scenarios?
  - What are the consequences of failure? Are there LOC or LOM consequences?
- Criteria 2: Time Critical
  - Is this a time-critical use case on a short time scale (hours) or does it affect sleep across multiple days? Does this use case have the possibility to pose a threat to crew health and performance under communication delay or blackout?
- Criteria 3: Workload, Manpower, Experience



- Does this use case require high mental workload, high manpower, or expertise in such a way that may drive crew size requirements? Does this use case include instances of multitasking (i.e., communicating while also performing science)?
- Criteria 4: Details for Modeling
  - What are the mission objectives for this use case?
  - What are the parameters that can be modeled in IMPRINT? Do detailed relevant analog procedures or schedules exist (which are needed to build certain types of models)? Do procedures have communication call outs so that we know the frequency of communication between crew and ground and the type and criticality of that information (or alternately, can we observe this task to gather this information)? Does the task require more than one person? Are interfaces listed in the procedure?
- Criteria 5: Framework Analysis
  - Will output be useful to evaluate against the trade space evaluation framework? Will this inform crew size?

The assessment team discussed candidate use cases using the criteria listed above and decided on a final set of four use cases to model that could reasonably be built given access to the data needed for modeling and that would also be informative across the dimensions of the trade space. The four models include use cases necessary to meet primary mission objectives and use cases to respond to unforeseen failures and align with use cases currently under development by the MAT.

The assessment team selected three Mars mission use cases to build as IMPRINT models:

- **IV Operations for Planetary Surface EVA Model:** modeling the mental workload of the IV Mars crewmembers supporting a planetary surface technical EVA.
- **Robotic Arm Assisted EVA Operator Model:** modeling the mental workload of a Mars crewmember controlling a robotic arm while concurrently monitoring an automated system.
- **Mars Transit Crew Model:** modeling the level of engagement (daily workload) of the Mars crew on the transit to Mars.

The assessment team selected a fourth Mars mission use case to develop a custom model for:

- **Personnel, Expertise, and Training Model:** modeling in-mission expertise necessary to meet primary mission objectives and to respond to an unforeseen failure.

While the assessment team attempted to select use cases to model that were as vehicle agnostic as possible (i.e., avoiding ascent/entry vehicles for which workload is highly dependent on the design) while being relevant for missions to Mars, the models are based on ISS vehicle and operational data given that ISS is currently the most relevant analog mission for Mars. As Artemis capabilities including new Artemis suits, airlocks, robotic arms, rovers, etc. become operational, models should be updated to better reflect the demands on the crew given the mission architecture.

The assessment team had initially selected five models to build that included modeling responding to a cooling loop failure (an event that occurred on ISS). However, the team quickly learned that the most important issue in considering the crew size necessary for root cause diagnosis of a major malfunction (e.g., a cooling loop failure) is in comparing the mental workload of the crew performing root cause analysis with the mental workload of a large team on the ground working the same problem. While human performance modeling can model the mental workload of an individual, it cannot be used – at this time – to model and compare the summative mental workload of different teams of people.

The assessment team addressed the expertise necessary to respond to an unforeseen failure (the initial failure response but not root cause diagnosis) with a different modeling technique in the Personnel, Expertise, and Training model.

### **6.3.3 Create a Trade Space Evaluation Framework**

Militello et al. (2019), developed a trade space framework designed to assist decision-makers with analyzing trades associated with different crew sizes [ref. 4]. Militello’s team recognized that determining crew size “is a form of function allocation, which is an intrinsic piece of complex systems”<sup>9</sup>. Therefore, to develop a framework for evaluating crew size, Militello’s team first conducted a literature review on function allocation. They gathered an initial list of 156 factors to consider and developed these into a list of 24 factors grouped into eight dimensions (Figure 10).

---

<sup>9</sup> Militello et al. (2019) considered “crewing configurations” where they defined a crewing configuration as, “an allocation of functions among different agents in a complex system”. In this context, an agent can be a human (e.g., flight crew, ground support) or technological agent (e.g., robotic agent, automation, intelligent system). For this assessment, the team considered the crew size, that is the number of humans on the mission to Mars.



**Figure 10. Tradespace Dimensions for Evaluating Crewing Configurations**  
[ref. 19, Figure 8]

Militello et al. developed an evaluation worksheet to assist SMEs in comparing crew sizes considering the factors in each dimension of the trade space. The assessment team adapted the evaluation framework developed by the Militello team into a framework for use by NASA. The assessment team edited the Militello team’s framework and evaluation worksheet to change to language used by NASA, and the assessment team added an additional category recognizing that human health and performance is a critical dimension in the trade space for NASA missions, leaving the criteria for this category to be determined by medical researchers. (Figure 11). The dimensions of the trade space include considerations of mission design parameters (e.g., the communication infrastructure can be considered in technology capabilities and operational decisions can be considered in organization constraints). The use of the evaluation framework is described below in the subsection Perform Trade Space Analysis.

## Trade Space Framework for Evaluating Crew Sizes

The following trade space framework can be completed as a heuristic or used to guide specific analyses.  
In completing this matrix, trade-offs between different crew sizes and mission architectures should become explicit.

### Operational Impact

*The factors here are designed to assess how well the crew complement supports mission effectiveness for the expected concept of operations. It requires an understanding of the Mars mission environment, NASA's Moon to Mars objectives, and the risk posed to crew and equipment.*

Factor	NASA Strategy for Assessment	Option 1	Option 2
<b>Safety Risk</b>			
Does the crew complement aid managing risk and maintaining survivability? Does the crew complement allow NASA to crew the mission in a way that manages risk as best as possible?	Describe how each crew complement may impact crew safety (considering risks including those managed by NASA's risk boards).		
<b>Mission Objectives</b>			
Will the crew complement positively impact mission success? Considerations include meeting NASA's major mission objectives documented in the <i>Moon to Mars Objectives</i> (September 2022).	Explore each crew complement's impact on mission success.		
<b>Mars Mission Environment (including hazards and communication infrastructure)</b>			
Does the crew complement meet the demands of a mission to Mars? Consider aspects of the Mars mission environment including the deep space and planetary surface environment, space flight hazards, and the communication infrastructure.	Identify areas of concern with regards to operations for a mission to Mars, in particular crew autonomy from MCC during significant comm delays.		

### System Resilience

*The factors in this category are designed to determine how well the crew complement accommodates (or hinders) performance in unexpected situations where adaptation and dynamic re-planning are required.*

Factor	NASA Strategy for Assessment	Option 1	Option 2
<b>Crew Redundancy</b>			
Does the crew complement allow for handoff of key mission functions? When crew members are task saturated or incapacitated, who or what could provide backup for functions such as: piloting, conducting EVA operations, conducting robotic operations?	Utilize a crew qualification and responsibilities matrix (CQRM) to identify important redundancies and/or identify the absence of critical redundancies.		
<b>Task Redundancy</b>			
Are there backup mechanisms for accomplishing the task if technology fails? Consider tasks related to: piloting, EVA operations, robotics operations, communication systems.	Utilize a structured methodology (such as a coded abstraction hierarchy and/or contextual activity templates) to identify important redundancies and/or identify the absence of critical redundancies.		
<b>Off-Nominal Events</b>			
How well does the crew complement support the crew in adapting to unanticipated events? More critically, how well does the crew complement support the crew in responding to unforeseen failures (where an unforeseen failure is of unknown origin and does not have published procedure)?	Explore different off-nominal events with SMEs and stakeholders and report on their impact with regard to each configuration. Utilize a crew qualification and responsibilities matrix (CQRM) to identify necessary expertise to respond to unforeseen failures.		

### Human Performance

*This category contains factors relating to how well the crew complement aligns with crewmember capabilities, strengths, limitations, and training, including manageability of tasks such as time management and real-time changes and decision-making.*

Factor	NASA Strategy for Assessment	Option 1	Option 2
<b>Workload</b>			
How does the crew complement affect cognitive and physical workload? Consider workload spikes and troughs.	Through IMPRINT, examine the workload associated with elements of the crew configurations. Highlight potential sources of high workload as identified by SMEs, stakeholders, or members of the project team. Through CQRM modeling, examine the training workload associated with crew configurations.		
<b>Reliability</b>			
Are the crewmembers assigned tasks they can reliably perform? Does the configuration rely on humans exceeding perceptual, motor, or cognitive abilities such as reaction time or memory? Are humans expected to passively monitor automation? Will humans need to take over when automation fails?	Identify instances where agents (both human and automation) are assigned tasks they cannot be expected to perform reliably.		
<b>Skill Acquisition &amp; Proficiency Training</b>			
Do crewmembers require specialized competency, training, or experience? Will the crewmembers require ongoing proficiency training to compensate for perishable skills? Will the crewmembers require increased training to support an understanding of automated systems?	Describe how each crewing configuration may impact the need for additional training.		

### Team Coordination

*This category contains factors related to how well the crew complement supports coordination among crewmembers and automation. This category also explores the allocation of functions in terms of coherence and responsibility, as these factors shape crew performance and coordination needs.*

Factor	NASA Strategy for Assessment	Option 1	Option 2
<b>Coherence</b>			
Does the crew complement create coherent sets of tasks (i.e., no left-over or conflicting tasks) for each crewmember? Is any crewmember assigned tasks that rely on another crewmember's action (i.e., interdependent tasks)? Where will coordination between crewmembers be required to accomplish tasks?	Highlight instances where humans are assigned left-over tasks. Identify activities where there is a known conflict or interdependence between activities. This will highlight where team coordination is required.		
<b>Responsibility</b>			
Does the crew complement create a clear structure of responsibility? Does the configuration create instances of divided responsibility between which agent (either human and automation) carries out the task and which agent is responsible for the task? What are the resulting coordination needs?	Identify instances of divided responsibility. Identify activities that will require human monitoring. This will highlight where team coordination is required.		
<b>Ease of Coordination</b>			
Does the crew complement facilitate the coordination needs of the crew? In what ways does the Mars mission environment hinder the coordination needs of the crew?	Knowing where team coordination is required will help identify situations in which coordination might be challenging or impossible.		

### Cognitive Support

*These factors relate to how well the crew complement supports human decision making and other cognitive activities.*

Factor	NASA Strategy for Assessment	Option 1	Option 2
<b>Situational Awareness</b>			
Does the crew complement promote each crewmember's situational awareness about the activity being performed? Consider crewmember's ability to perceive the environment, make sense of the situation, and anticipate the future status of the situation.	Describe instances where the crew complement could facilitate or hinder situational awareness.		
<b>Shared Mental Models</b>			
Does the crew complement support a shared understanding among crewmembers? Consider how well the configuration supports shared: Understanding of the goals, plans, priorities, and intentions of other crewmembers. Understanding of other crewmembers' activities and where they are focusing their attention. Understanding of the status, capacity, strengths, and limits of other agents (both human and automation). Understanding the current situation and how it evolves over time.	Describe instances where the crew complement could facilitate or hinder shared mental models.		
<b>Curiosity</b>			
Does the crew complement facilitate noticing and responding to anomalies?	Describe instances where the crew complement could facilitate or hinder noticing anomalies.		

### Organizational Constraints

*These factors are meant to capture organizational requirements and capture cultural issues within NASA that may affect or be affected by the crew complement.*

Factor	NASA Strategy for Assessment	Option 1	Option 2
<b>Explicit Constraints</b>			
Does the crew complement align with stated NASA procedural requirements (NPRs), standards (e.g., NASA-STD-3001), and/or flight rules?	Identify known areas where the crew complement does not align with explicit requirements or flight rules.		
<b>Implicit Constraints</b>			
Does the crew complement align with common practice or culture?	Identify known areas where the crew complement does not align with implicit restrictions.		

### Costs

*The factors in this category are designed to highlight classes of costs associated with each of the crew complements.*

Factor	NASA Strategy for Assessment	Option 1	Option 2
<b>Procurement</b>			
What is the cost to develop, acquire, integrate, or implement the functions that are required for the crew complement? What is the cost to develop, acquire, integrate, or implement the technology that is required for the crew complement?	Outline variables that may influence costs associated with each crew complement.		
<b>Operations &amp; Maintenance</b>			
What is the cost to operate and maintain the required technology?	Outline variables that may influence costs associated with each crew complement.		
<b>Personnel</b>			
What are the implications of the crew complement on ongoing personnel costs?	Outline variables that may influence costs associated with each crew complement.		
<b>Training &amp; Skill Maintenance</b>			
What are the costs associated with the required training and skill maintenance?	Outline variables that may influence costs associated with each crew complement.		



Technology Capabilities			
<i>The factors in this category serve as a place to capture and evaluate the technologies that are critical to make each crew complement feasible to implement safely and effectively.</i>			
Factor	NASA Strategy for Assessment	Option 1	Option 2
<b>Criticality</b>			
How critical is each required technology to the crew complement?	Rank the technologies in terms of criticality to the crew complement.		
<b>Feasibility</b>			
How feasible and reliable is each required technology for tactical use?	Discuss the feasibility of each technology in terms of its use to meet major mission objectives.		
<b>Integration Considerations</b>			
Are the required technologies compatible?	Identify salient integration considerations.		

Human Health & Performance			
<i>The factors in this category relate to how well the crew complement supports the physical and behavioral health of the crew.</i>			
Factor	NASA Strategy for Assessment	Option 1	Option 2

**Figure 11. Trade Space Framework for Evaluating Crew Sizes**  
[ref. 19, Figure 9]

### 6.3.4 Conduct Human Performance Modeling

With the use cases selected, the next step in the methodology is to conduct human performance modeling to provide quantitative data to aid decision-makers as they evaluate the dimensions in the trade space. Section 7 provides details for each of the models.

Three of the models developed by the assessment team were built using the Army’s IMPRINT modeling platform augmented with the NASA tailored S-PRINT plug-in. The models were based on analog vehicles, systems, or missions (e.g., ISS) with added assumptions about crew tasking, communication issues, reliance on automation, and other opportunities associated with missions to Mars.

The data collected by the assessment team for the models included existing NASA procedures, observations of real-time ISS operations, and SME input collected via structured interviews. Although it is too early in the design of Mars missions to validate model results, the fact that the models were built using IMPRINT and its robust mental workload model, Multiple Resource Theory (MRT), provided the assessment team with a leveraged, validated platform. IMPRINT and MRT have been validated as Department of Defense industry standards for human performance modeling, manpower analysis, and mental workload analysis. IMPRINT was validated as a human performance modeling tool [ref. 25]. MRT has been validated as an industry standard in mental workload analysis [refs. 26, 27, 28]. IMPRINT model outputs include quantitative data on mental workload and quantitative on level of engagement (daily workload).

The fourth model the assessment team built was a custom-designed model based on the ISS CQRM, a well-established tool used and maintained by the International Partners in the ISS Program to identify the minimum crew qualifications for each area of responsibility necessary for an ISS mission [ref. 29]. The data collected by the assessment team for the model included

existing NASA training data and SME input. The output of the model is flight-assigned Mars CQRM with quantitative data that informs the level of expertise within a crew of a given size.

**F-3.** The DoD IMPRINT tool augmented with the NASA tailored S-PRINT plug-in provides NASA with quantitative analysis capability for crew size decision-making using human performance modeling.

### **6.3.5 Perform Trade Space Analysis**

The final step in the methodology is to perform an analysis of the trade space comparing different crew sizes for missions to Mars against trade space dimensions using quantitative data from human performance modeling. The trade space evaluation worksheet provides guidelines for SMEs in making comparisons across the dimensions. The results of the analysis can be used to make recommendations to decision-makers as they consider the potentially competing goals in deciding on the crew size. Section 7 provides details for the analysis of each of the models.

As an example, the IMPRINT model outputs quantitative data on mental workload. In considering the human performance dimension of the trade space, model data can be used to compare the workload of two different crew sizes. The same two crew sizes can be compared across other dimensions of the trade space, including considering model assumptions on mission design parameters (e.g., technologies or communication infrastructure).

The evaluation framework is meant as a guide for analysis. For the models in this assessment, questions in the evaluation worksheet were adapted to the particular use case being modeled. Each model is analyzed against a subset of the dimensions in the trade space relevant to that model. The assessment team did not consider cost or health requirements in their evaluations. The MAT is considering cost in their work on crew size (along with other factors), and the Human System Risk Board oversees health requirements for human missions.

### **6.3.6 Summary of Proposed Solution**

Crewmembers on missions to Mars will be operating in hazardous environments, including in a deep space microgravity environment on the transit to and from Mars and in a reduced gravity environment on the Mars planetary surface. Given the communication delay/blackout associated with these missions, the crew will be required to operate semi-autonomously from the MCC, and depending on the communication infrastructure, the crew may also be required to operate autonomously for up to ~3 weeks during the mission and operate semi-autonomously or autonomously from each other when the crew is split between the vehicle in Mars orbit and the rover on the planetary surface. Their mission goals include landing on Mars, performing scientific research during planetary surface EVAs, and safely returning to Earth.

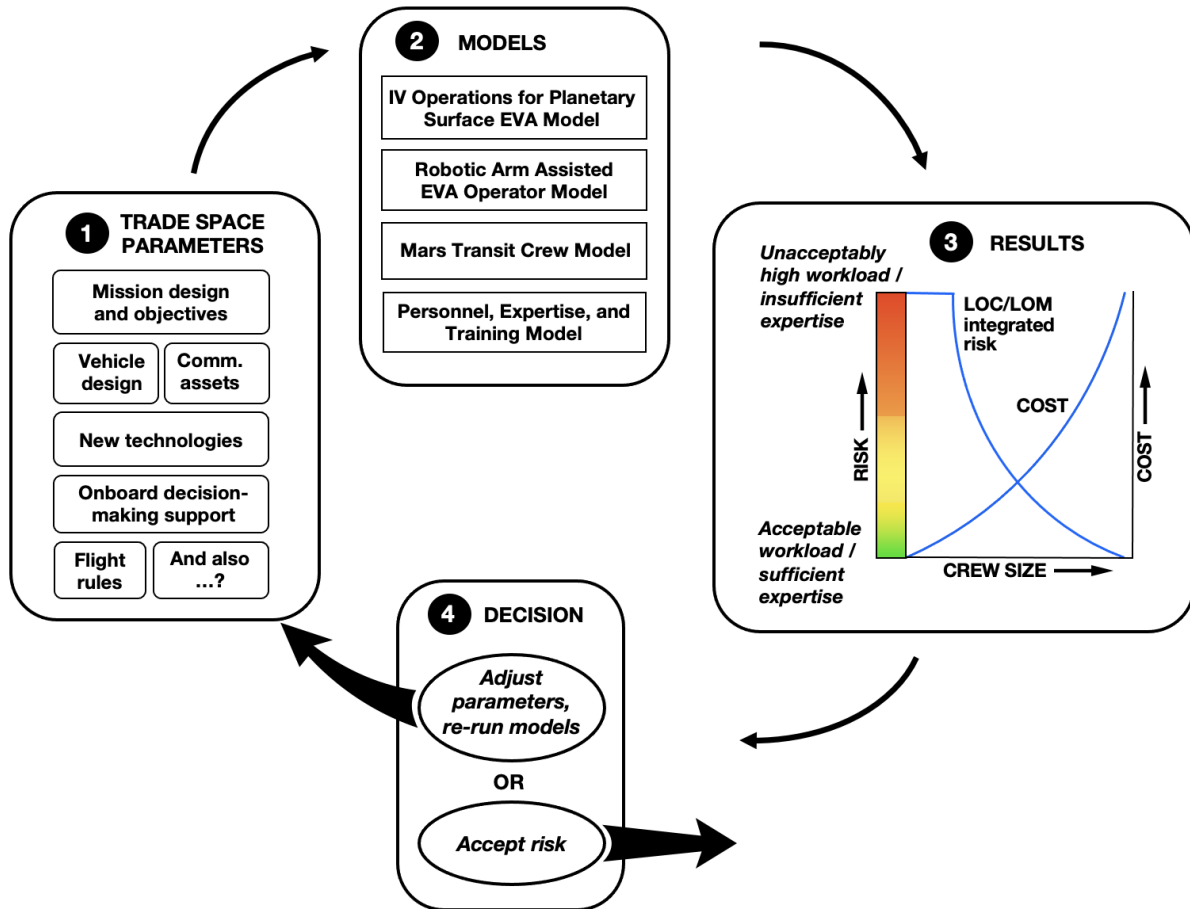
The decision on the crew size, specifically the number of crewmembers for such a mission, includes considering trades across multiple dimensions of the trade space. To assist decision-makers with analyzing trades associated with different crew sizes, the assessment team proposed a methodology for NASA to perform systematic, repeatable trade space analysis comparing crew size for missions to Mars against trade space dimensions using quantitative data from human performance modeling.

The steps in the methodology include gathering the contextual knowledge about the mission necessary to build human performance models, selecting use cases to model that include nominal operations but also include corner cases, and then building and analyzing the models against an



evaluation framework that covers the dimensions in the trade space. The results of the analysis can be used to provide recommendations to decision-makers.

As decision-makers consider crew size, if the risks to the mission from a given set of models results (and recommended crew size) show unacceptable risks, modelers can adjust model parameters and re-run models (Figure 12). The process can be repeated as new technologies are developed and updated mission assumptions are defined.



The NESC’s proposed methodology to aid crew size determinations. Trade space parameters are input into any/all of four models, whose output characterizes the risk level associated with a given crew size.

Decision makers may choose to adjust input parameters and re-run the models or accept the risk.

*Figure 12. Mars Crew Size Decision Process*

The assessment team used this methodology to build four models for an initial trade space analysis for crew size for missions to Mars. The details of the models and analysis are discussed in Section 7.

## 7.0 Human Performance Modeling and Trade Space Analysis

### 7.1 Listing of the Models

As described above, the assessment team selected four uses cases to model for this assessment. This includes a set of three human performance models using IMPRINT, a human systems

integration analysis modeling platform built for the military to model workload at various levels, and a fourth model of human expertise developed independently by the assessment team.

The three IMPRINT models were built based on Mars mission use cases:

- **IV Operations for Planetary Surface EVA Model:** Modeling the mental workload of the IV Mars crewmembers supporting a planetary surface technical EVA.
- **Robotic Arm Assisted EVA Operator Model:** Modeling the mental workload of a Mars crewmember controlling a robotic arm manually or in an automated control mode.
- **Mars Transit Crew Model:** Modeling the level of engagement (i.e., daily workload) of the Mars crew on the transit to Mars.

The fourth custom-built model was based on a Mars mission use case:

- **Personnel, Expertise, and Training Model:** Modeling crew expertise necessary to meet primary mission and objectives and respond to unforeseen failures.

This section of the report provides more information on human performance modeling and then provides detailed information on each model and modeling results and trade space analysis for crew size for missions to Mars.

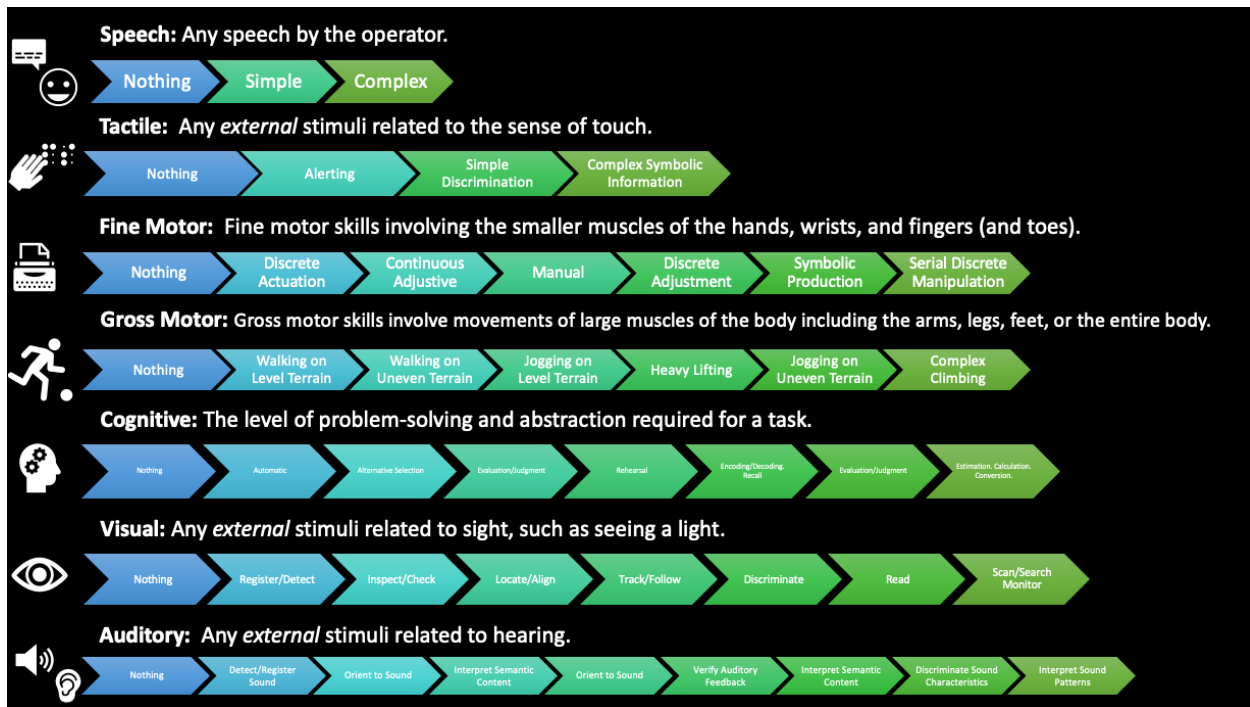
## **7.2 Modeling and Analysis**

### **7.2.1 Human Performance Modeling Introduction**

A human performance model dynamically simulates the complex behavior of human operators with an executable task network diagram. Examples of human behavior include the decisions be made, time to perform different tasks, potential for task errors, and consequences of those task errors. The assessment team conducted performance, workload, and crew engagement analyses for operationally relevant scenarios using the IMPRINT. IMPRINT is a dynamic, stochastic, human performance modeling software tool designed to assess the interaction of operator and system performance throughout the system lifecycle from concept and design to field testing and system upgrades. The U.S. Army Research Laboratory, Human Research and Engineering Directorate (ARL HRED) developed IMPRINT to support HSI. Our team conducted two different types of analyses using IMPRINT, namely: 1) detailed human performance models of crewmembers performing specific activities and using specific systems, called operation models, and 2) higher level manpower analysis models that focus on crew utilization over longer periods of time, including during periods in which unexpected events occur, called force models.

#### ***Mental Workload***

Mental workload in IMPRINT represents the operator mental capacity utilized, associated with different resource channels, when an operator performs tasks during the course of a mission. Every task performed by an operator is assigned workload values for applicable resources including visual, cognitive, fine motor, gross motor, auditory, speech, and tactile (Figure 13). Tasks can require several different resources to perform. For example, steering a car requires visual resources (watch where you are going), cognitive resources (decide if you are turning enough), and fine motor resources (moving the steering wheel). When an IMPRINT model is executed, IMPRINT generates a timeline of workload for each operator during a mission segment.



**Figure 13. Workload Resources in IMPRINT**

Workload calculations are especially important when an operator is performing a complex task or multiple tasks simultaneously. IMPRINT utilizes MRT (Wickens, 2002) – a human engineering standard for quantitatively assessing mental workload, to calculate workload over time for each operator associated with a mission [ref. 28]. MRT calculates an overall workload score that includes all single task demands plus a conflict score that measures task interference between two or more concurrently performed tasks. It further assumes that the interference varies depending on the time-shared mental resources. For example, the interference between a visually demanding task and a speech task may not be as severe as two visually demanding tasks.

A definition of the workload threshold in MRT, or the “red-line,” is “the point where one traverses safe and effective multi-tasking to dangerous and ineffective multi-tasking” [ref. 26]. The default workload threshold in IMPRINT is 60 and is based on 18 workload studies [ref. 27]. Overall workload in MRT is calculated by summing the single task demand scores across all resources utilized (e.g., visual, cognitive, and fine motor) along with conflict scores between resources. IMPRINT models can be coded to affect operator performance when overload occurs. For example, tasks can be delayed, dropped, or take longer to perform.

### ***Consequences of High Mental Workload***

Sustained periods of workload above a threshold can lead to poor performance. IMPRINT has a long history of use in examining proposed new Army systems, and analyzing different system design and crew task allocations, to determine potential multi-tasking scenarios that could lead to overload conditions and poor performance. In addition to MRT and the associated work performed by Wickens, Mitchell and Samms [ref. 30] cite a baseline theory of an inverted U chart of task performance to mental workload (Figure 14), based on work performed by Yerkes and Dodson [ref. 31].



**Figure 14. Task Performance versus Mental Workload**

Many studies have shown that periods of high mental workload can have consequences on human performance. Wickens states that “excessive workload is an undesirable state, contributing to errors, or the failure to manage unexpected extra tasks” [ref. 28]. High mental workload can change the way the person processes information and responds to task demands. An operator experiencing high workload may fail to detect certain signals, may delay responses during peaks in workload and attempt to catch up during lulls, systematically disregard some information according to a priority scheme, and may make less precise responses [ref. 32]. A consequence of high workload that has been identified in aerospace is attentional tunnelling, where attention becomes excessively focused on one aspect of a task, which may lead to some tasks not being attended to [ref. 33]. Workload that is unpredictable and/or that involves rapid increases can significantly increase the likelihood of human error [ref. 34].

- F-4.** Research literature and prior mental workload studies performed with human performance modeling tools (e.g., IMPRINT/S-PRINT) and utilizing MRT indicate that there are consequences of high or unacceptably high mental workload, including:
1. Task performance errors.
  2. Increased likelihood of task shedding.
  3. Degraded detection of and response to off-nominal events.
  4. Failure to detect and manage unexpected extra tasks.

During future Mars missions, with limited crew sizes and assumed crew autonomy due to communication delay/blackout, high crew mental workload could have significant operational consequences. For example, it may be assumed that the crew is more reliant on automated systems. However, if these automated systems fail, while at the same time decrease the crew’s situation awareness of the tasks they are performing, a crew experiencing high mental workload, and thus reduced capacity for resilient performance, may not notice, diagnose, or correct failures in a timely manner. Even in well-understood, ultra-safe commercial aviation systems that have undergone rigorous operational certification, airline pilots intervene to address automation malfunctions on 20% of normal (routine) flights [ref. 7]. Thus, it is likely unrealistic to expect that these automation system failures on Mars missions will be rare "corner-case" events.

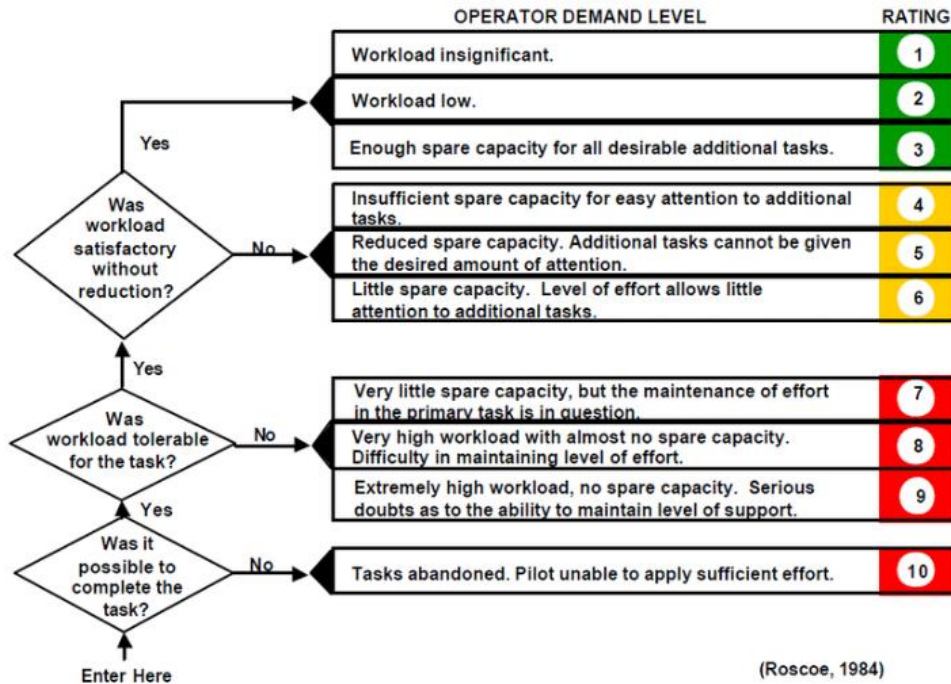
As research shows, humans are a “resource necessary for flexibility and resilience” in complex, engineered systems [ref. 8]. Successful missions to Mars will only increase in complexity compared with the challenges of LEO and lunar missions, and it is critical that human performance is appropriately considered in the design of these missions. Results from human performance modeling can be used in considering the workload and associated adaptive capacity of the crew, among other factors in the trade space, as planners consider trades in designing missions and as decision-makers decide on crew size.

### ***Categorizing Levels of Mental Workload***

For individual model executions, IMPRINT provides charts showing operator workload over modeled scenario time. An analyst can quickly look at these charts to see if operators are predicted to have high workload spikes above the MRT redline of 60, how high the spikes go, how often they may occur, and how dense overall mental workload attentional demands are over the course of a scenario. These workload over time reports can also be collaborated with another report, the operator workload detail report, that shows which tasks the operator was performing that led to changes in overall workload at every event time stamp of model execution. This allows an analyst to study what multi-tasking led to the highest workload peaks.

IMPRINT also allows an analyst to generate a report of all data used to create the workload over time charts. This data can be parsed and post-processed to determine two other telling workload metrics; time-averaged workload over the course of the scenario run and percent time in overload. These metrics can be used in more detailed comparative analyses between modeled crew/system configurations and scenario conditions (e.g., occurrences of off-nominal events or operator fatigue).

In NASA-STD-3001 Technical Brief - Cognitive Workload [ref. 35], a figure very similar to the one shown above in Figure 14 is shown to illustrate the need to consider cognitive underload and overload workload conditions. Additionally, the Bedford Workload Scale is presented as an option to evaluate workload demands as they relate to an operator’s (a pilot in this case) ability to perform a scenario and associated tasks (Figure 15).



**Figure 15. The Bedford Workload Scale**

The Bedford Workload Scale characterizes a person’s workload with respect to the spare capacity to perform other tasks by asking that person to answer three questions. The 10 Bedford scale rankings are broken into three groupings that are associated with the traditional stoplight colors; green (workload is not an issue that impacts task performance), yellow (workload is starting to have some impact on an operator’s ability to perform tasks), and red (workload will most likely have a significant impact on the performance of tasks).

Similar to the Bedford scale, the MRT workload scores generated by an IMPRINT model over modeled scenario time indicate an operator’s capacity to perform tasks. Mapping two of the three IMPRINT workload metrics captured in this effort, percent of scenario time spent in overload (above 60), and time-averaged workload, yielded the broad categories, similar to those associated with the Bedford scale, per the logical flow bullets below. Workload peaks were not included because high peaks of a very short duration may not have an impact on an operator’s ability to perform tasks as they may briefly delay some tasks that would put them into overload. However, numerous high workload peaks, and those of longer durations, will drive up the other two metrics, thus they are included in this analysis.

**Green** (workload is “acceptable” and will not impact task performance)

- Percent time in overload is less than 3%
- AND
- Time-averaged workload is less than 30.0

**Yellow** (workload is “high” and may impact task performance)

- Percent time in overload is greater than 3% but below 30%
- OR
- Time-averaged workload is above 30.0 but below 40.0

**Red** (workload is “unacceptably high” may severely impact task performance)

- Percent time in overload is above 30%
- OR
- Time-averaged workload is above 40.0

### ***Crew Utilization (Level of Engagement)***

For IMPRINT human performance models representing higher level activities instead of finite tasks (e.g., sleeping, conducting experiments, eating/personal time, exercise, and travel time) performed over longer time periods (e.g., the outbound Mars transit segment) crew utilization, or level of engagement, in different types of activities can be measured. Each crewmember can be placed on standard schedules that include all planned activities. Then “what-if” scenarios can be run with unplanned activities, or off-nominal events, scripted at different levels to see their impacts on crew utilization. Each activity needs to be prioritized to determine which ones will be performed and which ones will be sacrificed by higher priority activities. Crew utilization models allow an analyst to take a higher-level look at necessary crew sizes to accomplish longer duration missions.

## **7.2.2 IV Operations for Planetary Surface EVA Model**

### **7.2.2.1 Purpose and Scope**

The purpose of this element of the assessment was to examine the real-time activities necessary to support crew engaged in a Mars surface EVA and produce an estimate of the workload that would be experienced if these activities were performed entirely by crew in Mars orbit, without the ability for real-time communication with Earth. The IMPRINT modeling system was used to produce workload estimates.

This assessment focused on a Mars surface EVA scenario, in which two crewmembers, EV1 and EV2, perform a technical task. Although the main purpose of Mars EVAs will be scientific activities (e.g., sample collection) there is a possibility that some technical EVAs involving assembly or maintenance may be required. The scenario below is informed by the document “Reference surface activities for crewed Mars mission systems and utilization” (Document No: HEOMD-415, 2022).

## MARS TECHNICAL EVA SCENARIO

*A four-person crew arrives at Mars on board the Transit Habitat. The Transit Habitat enters Mars orbit and rendezvous with the Mars Descent Vehicle (MDV) that had previously arrived in Martian orbit. Two of the four crewmembers enter the MDV for descent to the Martian surface. The other two crewmembers remain on the Transit Habitat, which continues to orbit the planet serves as a communications relay back to Earth during the surface mission.*

*The crewmembers on board the Transit Habitat and the MDV communicate via text messages with the MCC, however due to a ~22-minute one-way delay, communication is restricted to issues that are not time-critical (e.g., timeline updates, minor off-nominal conditions, and procedures for scheduled tasks to be performed over the coming sols). The crew on the surface communicate real-time with the orbit crew via Mars communication assets.*

*The MDV lands on the Martian surface next to a pre-deployed power grid, and in the vicinity of two previously deployed cargo landers. The MDV is designed to be robotically connected to the surface power grid shortly after arrival. The mission plan has reserved sols 1-3 for lander crew re-adaptation to a gravity environment with no scheduled EVA activity.*

*Shortly after landing, the crew becomes aware that the robotic connection to the power grid has been unsuccessful. The orbiting crew and the lander crew attempt to resolve the issue in conjunction with the MCC. After 24 hours has elapsed, the problem has not been resolved, and the MCC on Earth decides that a contingency EVA is necessary to manually make the connection. The manual power connection contingency task had been planned for and has been rehearsed before launch and during the voyage to Mars.*

*The two crewmembers in the lander prepare for the EVA, with the two crewmembers in Mars orbit providing real-time support, guiding the EVA crew through procedures and checks, and helping to resolve issues as they arise. The two surface crewmembers exit the MDV using suitports that enable ingress and egress of the spacecraft while the spacesuit remains outside of the pressurized volume of the spacecraft. The use of suitports avoids the use of an airlock and simplifies the ingress and egress procedures. The orbiting crew receives real-time telemetry from the suits, and before the EVA crew detach from the MDV, the orbiting crew performs checks on the functioning of the suits. The orbiting crew receive real-time suit telemetry of suit parameters and crew physiological state and can see video from helmet mounted cameras in addition to cameras situated on the outside of the MDV.*

*With suit performance confirmed as nominal, the EVA crew detach from the MDV and walk towards the power connection. One member of the orbiting crew (flight director/IV) acts as flight director and communicator, providing a single point of verbal communication with the EVA crew, while also maintaining overall situation awareness. The other member of the orbiting crew manages all other tasks, including monitoring the status of the EVA suits, monitoring the physiological state of the EVA crew, calculating time remaining on consumables, providing assistance on task performance, and responding to any off-nominal conditions that may arise.*

*After successful connection to the power grid, the EVA crew return to the MDV and ingress via the suitports. Forty minutes after the completion of the EVA, the crew receive a congratulatory text message from the MCC.*

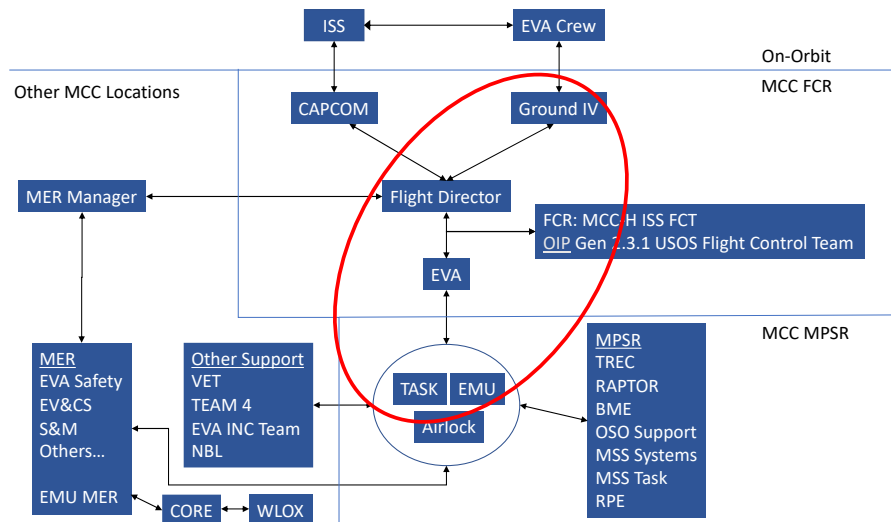


Several analogs or simulations were potential sources of data to estimate the workload involved in supporting a planetary EVA. These included NEEMO, BASALT, and historical records from Apollo. It was decided to use a recent ISS EVA as a real-world analog of a future Mars surface EVA due to the large amount of data that would be available from voice loops, video recordings, documentation, and interviews with personnel.

The focus of this assessment was the workload of personnel who support EV1 and EV2, rather than the EVA crew themselves. The extensive planning, training and other preparations that occur in the days, weeks, and months leading up to an ISS EVA are out of scope. A large number of personnel in the MCC, and support personnel in other locations are involved during EVAs, and it was not possible in the current assessment to examine the workload of all of these individuals. It was decided to focus on five core positions as shown in Figure 16. These positions were Ground IV, flight director, EVA flight controller, EVA Task flight controller, and Extravehicular Mobility Unit (EMU) flight controller.

ISS EVA79, performed in March 2022 was selected for analysis because it involved an assembly task and was performed without the use of the robotic arm. During EVA79 crewmembers Kayla Barron and Raja Chari (designated as EV1 and EV2) installed equipment in preparation for the later installation of an ISS Roll Out Solar Array (IROSA).

It is acknowledged that an ISS EVA and a Mars Planetary EVA will differ in many respects, however it was considered that many of the core MCC tasks required to support EV1 and EV2 during EVA79 will apply to a Mars EVA.



**Figure 16. MCC Positions**

### 7.2.2.2 Method and Procedures

A 2.5-hour period towards the end of EVA79 was selected for analysis. The selected period began at four hours and 20 minutes into the EVA and ended shortly before ingress. The methods of egress and ingress on future Mars missions are likely to be very different from current ISS procedures, therefore it was decided to exclude these phases from the current evaluation.

## Sources and Data Used

The following sources of data were used:

### *Voice Loop Recordings*

The frequency and duration of speech on several voice loops were analyzed, and speech was categorized according to whether the words were simple utterances (one or two words) or complex utterances (three or more words comprising a sentence).

### *SME Interviews*

Structured interviews were held with 12 SMEs who served in the following positions in support of EVA79: flight director, Ground IV, EVA, EVA Task, EVA Task OJT, EMU, Airlock, Surgeon, Biomedical Engineer (BME), Deputy System Manager, MER, Communications Rf Onboard Network Utilization Specialist (CRONUS), Environmental and Thermal Operating Systems Officer (ETHOS).

Each interviewee was asked the following open-ended questions:

- What are the main responsibilities of your position?
- What sources of information do you rely on to perform this role during EVA 79?
- What decisions or assessments did you need to make during EVA 79?
- What are the main actions that you took during EVA 79?
- For each activity that you performed during EVA 79, how frequently did it occur and how long did it take?
- Any other comments you would like to make?

## **Creation of IMPRINT Workload Models**

IMPRINT models were created to represent the workload of five MCC positions during ISS EVA 79. The five positions were Ground IV, flight director, EVA flight controller, EVA Task flight controller, and EMU flight controller.

For each of these five positions, the identified tasks, their frequency and duration were tabulated, and then entered into the IMPRINT modeling system. Each task was described using the following categories from the IMPRINT resources taxonomy: auditory, cognitive, fine motor, speech, visual. Workload values were then assigned to each task, guided by the recommendations contained in IMPRINT documentation. For example, listening to simple speech involved lower auditory and cognitive demands than listening to complex speech.

Each model covered three core performance elements: nominal performance, communications, and off-nominal performance. Tasks in each model are color-coded. Green boxes represent model tasks. These are functions (e.g., starts, ends, or pauses between tasks) performed by IMPRINT that enable the model to run correctly. Tasks performed by a person are shown in colors other than green.

A distinction was made between tasks that might occur in parallel (e.g., listening to crewmember speech and scanning a video display) and tasks which would not occur in parallel (e.g., referring to a procedure document while also scanning a caution and warning screen).

Each model was run ten times. Models contained probabilistic logic statements and uncertainty bands associated with task timings, with the result that no two model runs produced identical workload estimates.

For each position, two workload graphs were selected from the 10 model runs to illustrate (1) a run in which a complex off-nominal event was not introduced by the model, and (2) a run in which a complex off-nominal event did occur. Workload values throughout the 2.5 hours period were presented on the vertical axis of the graphs. An IMPRINT workload value of 60 is considered to be the threshold above which task saturation is likely.

### **Hypothetical Combination of Positions**

The five MCC positions were combined into two hypothetical EVA support positions that might conceivably be located on a spacecraft orbiting Mars. The two hypothetical positions were (1) combined flight director/IV, and (2) combined EVA Controller, comprising the tasks currently performed by EVA, EVA Task, and EMU positions. IMPRINT models were created for each of these hypothetical positions, and workload estimates were obtained.

### **Follow-up Interviews**

Follow-up interviews were held with SMEs. During these interviews SMEs were asked to evaluate whether the IMPRINT models were realistic and whether the resulting workload graphs seemed reasonable. They were then asked to comment on the hypothetical combined positions, including the workload graphs that expressed the estimated workload for these positions.

To guide the SME discussion of the hypothetical combined positions, SMEs were asked a set of probe questions based on the trade space evaluation [ref. 19]. The questions covered the impact of the proposed configuration on Resilience, Human Performance, and Coordination, and can be found in Table 1.

#### **7.2.2.3 Assumptions and Model Limitations**

For modeling purposes, the following assumptions were made concerning how a planetary EVA would be conducted on Mars:

- The support tasks necessary for a planetary EVA will share many characteristics with those involved in current ISS EVAs.
- All or most of the preparation and planning tasks performed in the days leading up to a planetary surface EVA work will be performed on Earth. Therefore, this work was not modeled.
- There will be no communication latency between crew orbiting Mars and surface EVA crew.
- Two crewmembers (EV1 and EV2) will conduct the EVA on the planetary surface.
- A support crew on orbit around Mars will provide all the real-time IV support to the EVA crew that is currently provided by the MCC.
- One-Way Light Time between Earth and Mars will be ~22 minutes, therefore there will be no real-time communication between crew at Mars and Earth.

*The following limitations concerning the current modeling activities should be noted:*

- There will be significant differences between an ISS EVA and a planetary EVA on Mars. Differences will include environment, gravity, equipment, communication latencies, tasks, and suit designs. Despite these differences, the experience gained from ISS EVAs can help us consider the future challenges of Mars EVAs.
- The suits used for Mars EVAs are envisioned to be more advanced than those currently used for ISS EVAs. It is expected that Mars EVA suits will be more robust, will contain more advanced features, and will require less real-time monitoring than current suits.
- Some of the support tasks currently performed by people may be automated in the future.
- The assessment can only model cognitive activities that are apparent from voice loops, console logs, and self-reports. It is likely that not all cognitive tasks will be captured.
- ISS EVA 79 progressed relatively smoothly, without significant complications. Therefore, it may provide a best-case analog for a planetary EVA.
- The potential effects of fatigue, deconditioning, stress, and other factors that could reduce cognitive performance were not included in the models.

*Specific assumptions used in creating IMPRINT models*

- The assessment did not model tasks associated with operation of spacecraft, habitats, or rovers.
- The dependencies between positions were not included in the models.
- All of the IMPRINT models simulate only one off-nominal at a time.
- The models did not include workload of assistant or OJT positions, or others involved in the support of EVAs.
- It was assumed that 70% of off-nominals could be resolved with a rapid response based on the controller's training and experience. A further 20% of off-nominals could be resolved with reference to documents (e.g., procedures or crib sheets). The remaining 10% of off-nominals would involve more complex problems and would require MCC personnel to prepare a procedure for the situation, with a corresponding increase in mental workload. The 7:2:1 ratio of off-nominals was arrived at based on judgment rather than statistical analysis.

#### **7.2.2.4 Results and Discussion**

##### **A Note about Exploration EVAs**

Any investigation of Mars crew workload during EVA must recognize the important differences between the carefully scripted assembly and maintenance EVAs so familiar to ground and flight crews on ISS missions and the exploration EVAs that will be the main activity conducted on the Martian surface. More than half a century has passed since humans last explored the surface of another world during the Apollo EVAs. While some of the work done on the lunar surface (i.e., setting up scientific instruments) bore a resemblance to ISS tasks, the scientific exploration that was the main purpose of the Apollo EVAs was by its very nature impossible to script ahead of time. Even though their traverses were carefully planned, what the crew did at each station stop was always, to some degree, a matter of reacting to the unexpected.

No one could have predicted, for example, Apollo 17 astronaut Jack Schmitt's discovery of orange soil at Shorty Crater, which proved to be one of the most important finds in the entire Apollo collection. For about half an hour, faced with an immutable walkback constraint, Schmitt and mission commander Gene Cernan worked quickly and intensely to collect samples and carry out photographic documentation. The episode illustrates the potential for unexpected spikes in crew workload during exploration EVAs. It is also important to realize that Cernan and Schmitt's sampling at Shorty was aided by frequent input from scientists in a back room of the MCC. This kind of real-time support will be unavailable to a Mars crew. Explorers on the Martian surface will essentially be on their own to make decisions and deal with unanticipated discoveries. Another factor is the advanced avionics planned for next-generation space suits that may offer risk reduction but will also increase the cognitive workload on the exploration EVA crew if tasking is shifted from the IV crew to the EVA crew.<sup>10</sup> All of these factors point to the need for additional study to assess crew workload during exploration EVAs.

### **Flight Director**

The flight director is in charge of operations and has the authority to make any real-time decision required to ensure the safety of the crew and ISS. The flight director is located in the Flight Control Room (FCR). The flight director interviewed in the current assessment considered that during an ISS EVA, around 90% of his attention would be directed at the EVA crew, and around 10% would be directed at more general ISS issues. However, if an off-nominal situation arose with the EVA, the ISS issues could be handed off to other personnel, enabling him to focus on the EVA issue.

ISS EVAs are tightly choreographed, so as to maximize efficiency by accomplishing as much as possible during each EVA. During task performance, the flight director's attention is most closely focused on the transitions between tasks. The specifics of task performance are managed by the EVA and EVA task position.

The flight director described his job as conducting risk trades in real-time. Around 90% of the time, EVAs proceed as planned. The flight director's main role is to deal with the other 10%. He considered that no EVA goes entirely according to plan. Off-nominals are to be expected during EVAs, and this is when workload for the MCC personnel becomes high. When things that are not going to plan his role is to gather everyone on the flight loop and lay out trades that need to be made to manage risk. He lays out decisions in plain language to ensure that everyone understands the plan and gives a time frame for the actions that need to occur. Clear verbal communication is critical, and he will often state the same thing twice in different ways to ensure it is clearly understood. He must assume that no matter what you say, someone did not hear you.

The flight director may have occasional airwave (face-to-face) communications with personnel in FCR, but important decisions are re-stated on the flight director loop, so that everyone can hear, and the decision is recorded.

---

<sup>10</sup> If tasking for suit monitoring is shifted to the EVA crew, then the crewmembers will experience increased cognitive workload assuming that the advanced avionics require human-machine teaming to operate effectively. For further reading, see Johnson, M. & Vera. H. (2019) *No AI is an Island: The Case for Teaming Intelligence*. AI Magazine. Vol. 40, No. 1.

The flight director will make a brief electronic log entry at the end of each significant task step and will also make log entries if an off-nominal situation arises, however, preparing notes is not a major task for the flight director.

**Table 1. Nominal Tasks for Flight Director Position during ISS EVA**

	<b>Nominal Tasks for Flight Director Position during ISS EVA</b>	<b>Estimated frequency</b>	<b>Estimated average duration (seconds)</b>
<b>Scan cycle</b>	Scan video display of EV crew	1.5 min	30
	Scan data screen, including cautions and warnings, communications displays	25 min	10
<b>Documents</b>	Refer to procedures, timeline, engineering documents, flight rules	7.5 min	35
	Prepare flight note, text message, or log entry	10 min	30
	Decide on plan adjustment (e.g., which get-aheads to do, when to end)	Ev 2 hr	180
<b>Monitor the room</b>	Observe or become aware of non-verbal activity in the MCC	1 min	2
<b>Speaking and listening</b>	Monitor comm loops	Constant	
	Pay attention to complex crewmember speech (sentences)	15 sec	7
	Pay attention to simple crewmember speech (one or two words)	1 min	1
	Pay attention to complex MCC speech (sentences)	5 min	4
	Pay attention to simple MCC speech (one or two words)	3 min	1
	Communicate complex speech (sentences)	2.5 min	4
	Communicate simple speech (one or two words)	2 min	1

## Off-nominal Tasks for Flight Director Position

During an off-nominal event, the flight director continues to perform the tasks listed in Table 2, with the exception of the following tasks. For modeling purposes, these tasks are assumed to be briefly paused while the off-nominal situation is resolved, or performed as part of the flight director's response to the off-nominal situation.

- Refer to procedures, timeline, engineering documents, flight rules
- Prepare flight note, text message, or log entry

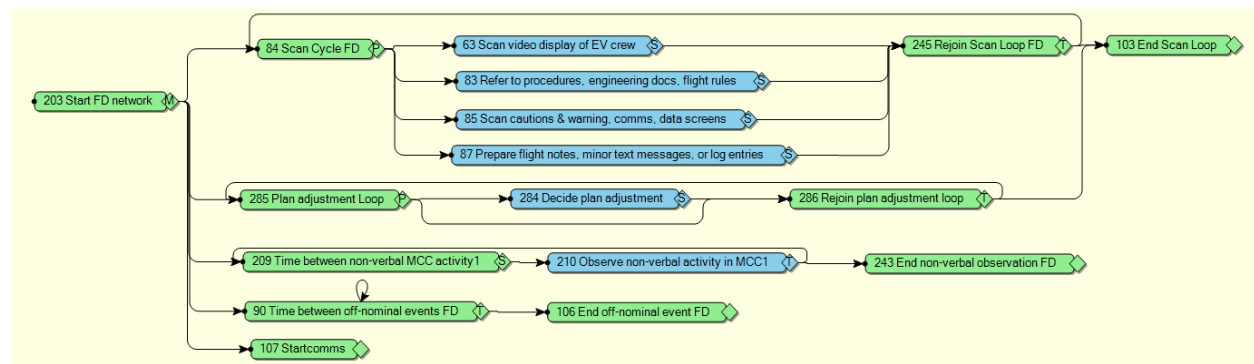
Depending on the nature of the off-nominal condition, one of the three following responses is made:

**Table 2. Off-Nominal Tasks for Flight Director**

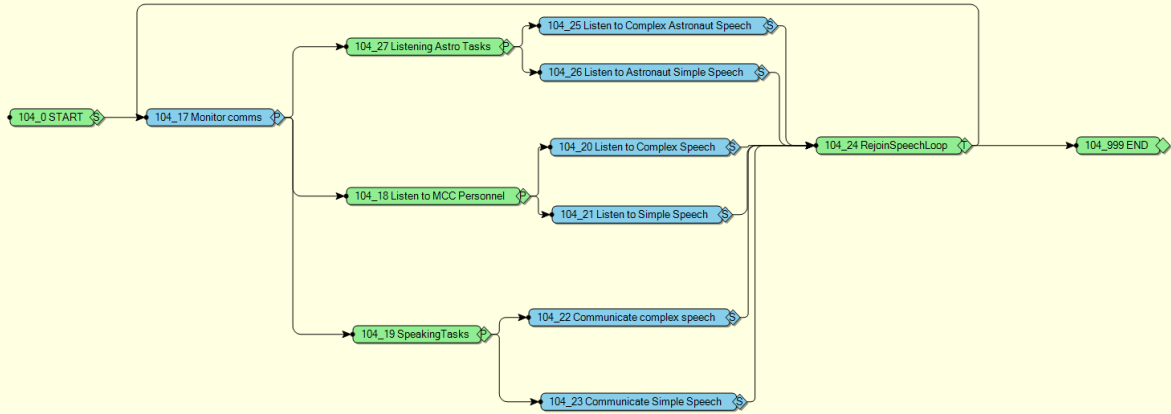
Off-nominal situation		Average frequency	Estimated average duration (seconds)
One of three possible responses to off-nominal:	1. Rapidly apply a prepared decision	Ev 45 min	5
	2. Decide action after referring to crib sheet, flight rules, or other document	Ev 2.5 hr	20
	3. Complex problem requires coordination with other MCC personnel	Ev 5 hr	300

## Flight Director Model and Results for ISS EVA

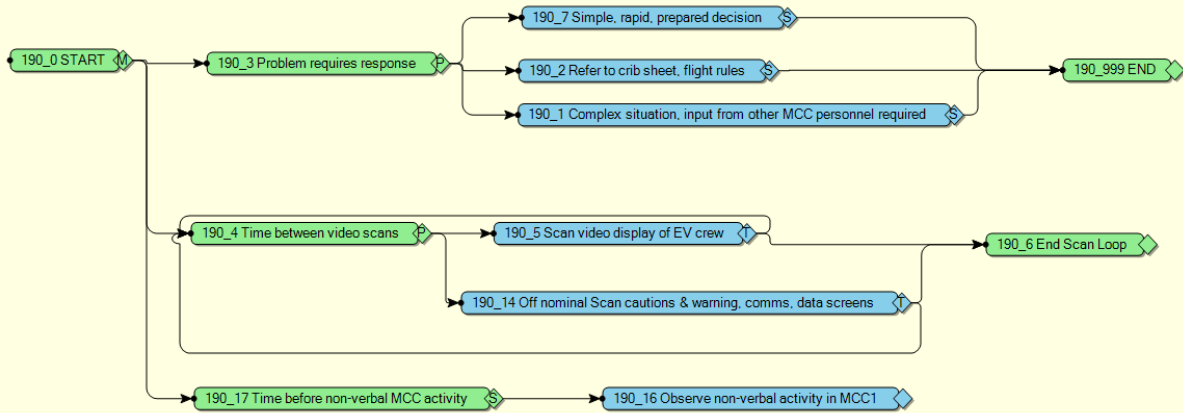
The task model for flight director contained three sections, shown below. These are nominal tasks (shown in Figure 17), communication tasks (Figure 18), and tasks that would be performed during an off-nominal event (Figure 19). During an off-nominal event, communication tasks continue; however, the nominal tasks shown in Figure 17 are paused and are replaced by the off-nominal tasks shown in Figure 19.



**Figure 17. Flight Director Nominal Tasks**



**Figure 18. Flight Director Communication Tasks**

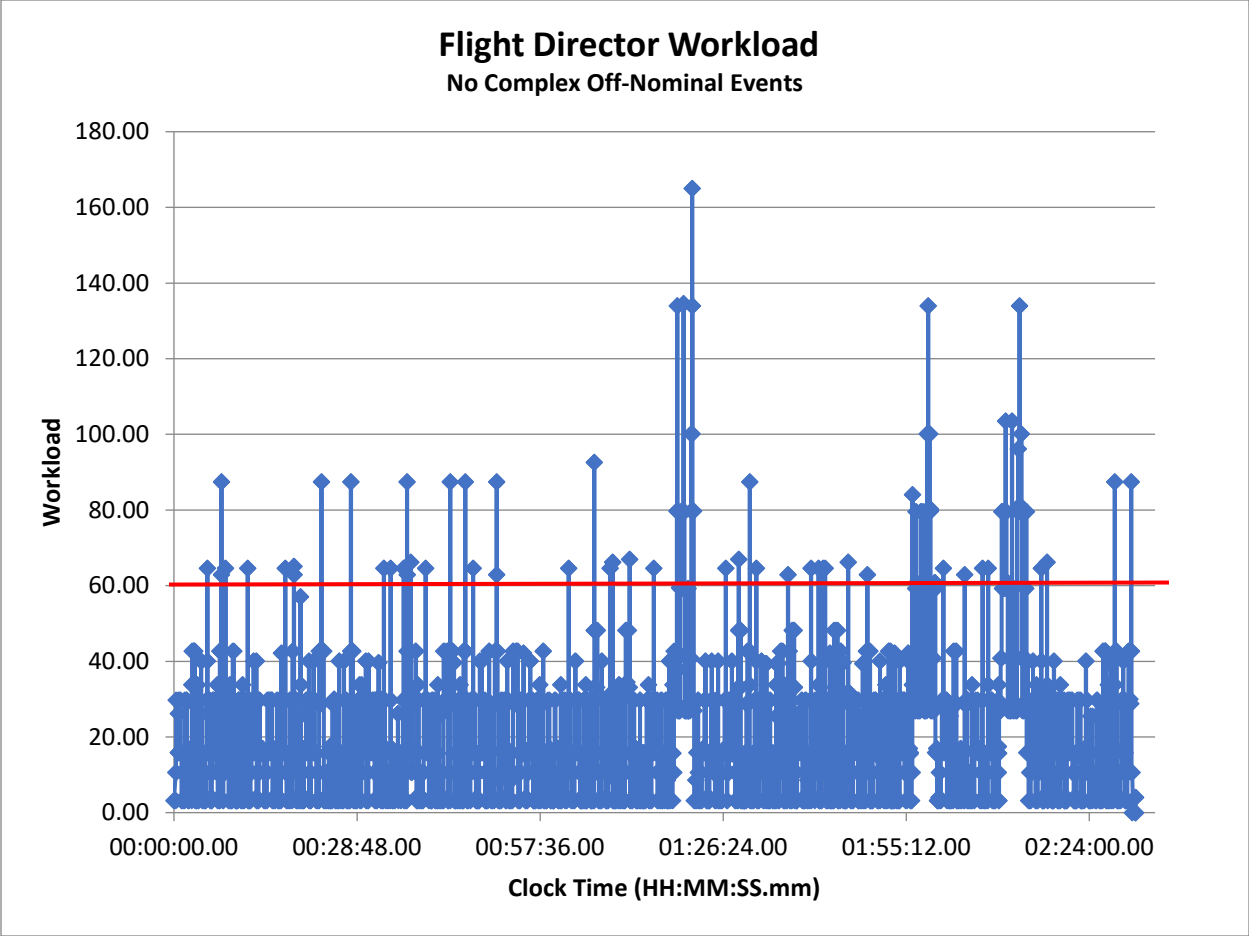


**Figure 19. Flight Director Off-nominal Tasks**

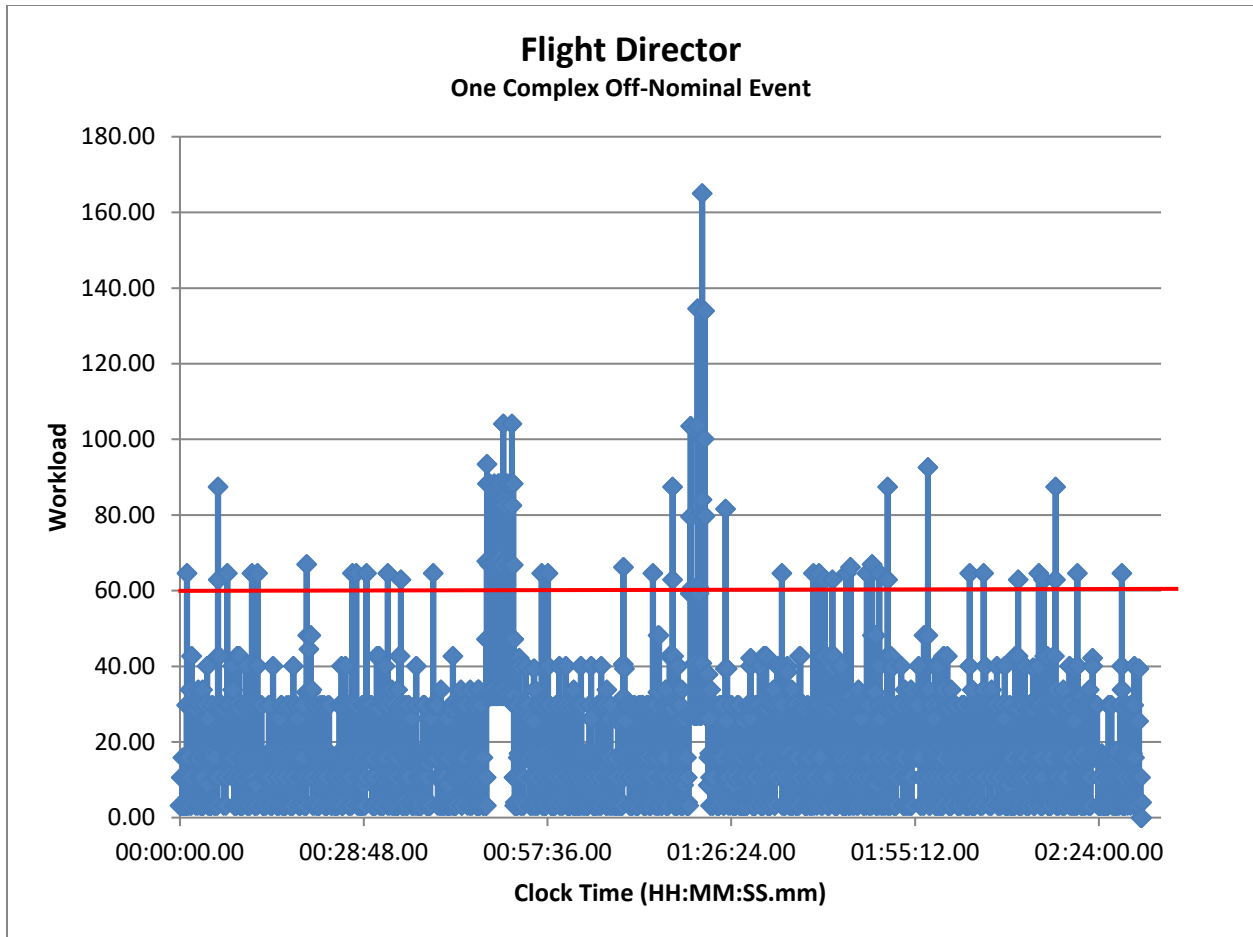
Figure 20 shows estimated workload for the flight director over a 2.5-hour period of an ISS EVA scenario generated by the IMPRINT model during which no complex off-nominal events occurred. Even without a complex off-nominal, workload is regularly predicted to spike above the 60 threshold.

Figure 21 shows estimated flight director workload for a 2.5-hour period during of an ISS EVA scenario generated by the IMPRINT model during which a complex off-nominal event occurred, around 48 minutes into the scenario. Some of the increased workload reflects conflicts between tasks that draw on the same mental resources.





*Figure 20. Flight Director Workload with No Complex Off-nominal Events*



**Figure 21. Flight Director Workload with One Complex Off-nominal Events**

Table 3 shows workload metrics produced by IMPRINT for two scenarios shown in Figures 25 and 26. Overall workload for the flight director was predicted to be “high” in the scenario without a complex off-nominal, and “acceptable” for the scenario involving a complex-off-nominal event. It may appear counterintuitive that the less complex scenario would involve a higher workload than the more complex scenario; however, it must be remembered that IMPRINT introduces random variation into each run, and the “high” outcome is due to the percent time in overload being slightly above the 3% threshold. The peak workload value of 164.97 occurred on several runs whenever four specific tasks were performed simultaneously. These tasks were: decide plan adjustment, listen to complex crewmember speech, observe non-verbal activity in the MCC, and refer to procedures, engineering docs, flight rules.

**Table 3. Flight Director Workload Metrics for 2.5-hour Period of an ISS EVA**

	Time-Avg Workload	Percent Time in Overload	Peak Workload
<b>No Complex Off-Nominal Events</b>	18.85	3.10	164.97
<b>One Complex Off-Nominal Event</b>	17.28	1.70	164.97

## **Ground IV**

The Ground IV is the communicator between the crewmembers performing the EVA (EV1, EV2) and the rest of the team in the MCC. The Ground IV is located in the FCR and is staffed only during EVAs. In addition to their role as a communicator, as a crewmember, the Ground IV is alert to subtle cues (e.g., speech, breathing, or behaviors) that could indicate that the crewmembers are becoming physically exhausted or fatigued (see Table 4).

ISS Flight Rules specify that there must be two-way voice communications between the crewmembers performing the EVA and the ISS. During shuttle orbiter EVAs, a crewmember (Intra Vehicle) communicated with EV1 and EV2. When the function was moved to the ground during ISS EVAs, the “Intra Vehicle” (IV) description was retained in the position title. The Ground IV SME described his scan pattern as “thin slicing”, where he briefly directs his attention to multiple inputs. He watches the crew as much as possible on video, but also pays attention to paper procedures and crib sheets, and occasionally glances at computer screens. He also maintains awareness of movement or activity in the FCR (e.g., body language or gestures). He constantly monitors auditory input, some from communication loops (notably Space-to-Ground, flight director, and EVA) and some from activity in the FCR.

During an EVA, EV1 and EV2 set the tempo and the MCC team on the ground follow. As the crew performs a task, the Ground IV reads steps and checks off procedures as they are completed, writing down actions (turns on bolts, etc.) to confirm that they have been completed. During an off-nominal situation, his attention is focused more on the video of the crew. For most off-nominals, there is a procedure or crib sheet.

**Table 4. Nominal Tasks for Ground IV Position**

	<b>Nominal Tasks for Ground IV Position</b>	<b>Estimated frequency</b>	<b>Estimated average duration (seconds)</b>
<b>Scan cycle</b>	Scan video display of EV crew	Ev 30 sec	10
	Scan data screen, including cautions and warnings, communications displays	Ev 15 min	5
<b>Documents</b>	Refer to procedures, engineering documents, flight rules	Ev 10 min	5
	Prepare flight note, text message, or log entry	Ev 10 min	5
<b>Monitor the room</b>	Observe or become aware of non-verbal activity in the MCC	Ev 1 min	2
<b>Speaking and listening</b>	Monitor comm loops	Constant	
	Pay attention to complex crewmember speech (sentences)	Ev 15 sec	7
	Pay attention to simple crewmember speech (one or two words)	Ev 1 min	1
	Pay attention to complex MCC speech (sentences)	Ev 6 min	4
	Pay attention to simple MCC speech (one or two words)	Ev 2 min	1
	Communicate complex speech to the MCC (sentences)	Ev 12 min	5
	Communicate simple speech to the MCC (one or two words)	Ev 5 min	1
	Communicate complex speech to Crewmembers	Ev 1 min	8
	Communicate simple speech to Crewmembers	Ev 30 sec	1

## Off-nominal Tasks for Ground IV Position

During an off-nominal situation, the Ground IV continues to perform the tasks listed in Table 5, with the exception of the following tasks, which (for modeling purposes) are assumed to be briefly paused while off-nominal is dealt with or performed as part of the Ground IV's response to the off-nominal.

- Refer to procedures, timeline, engineering documents, flight rules
- Prepare flight note, text message, or log entry

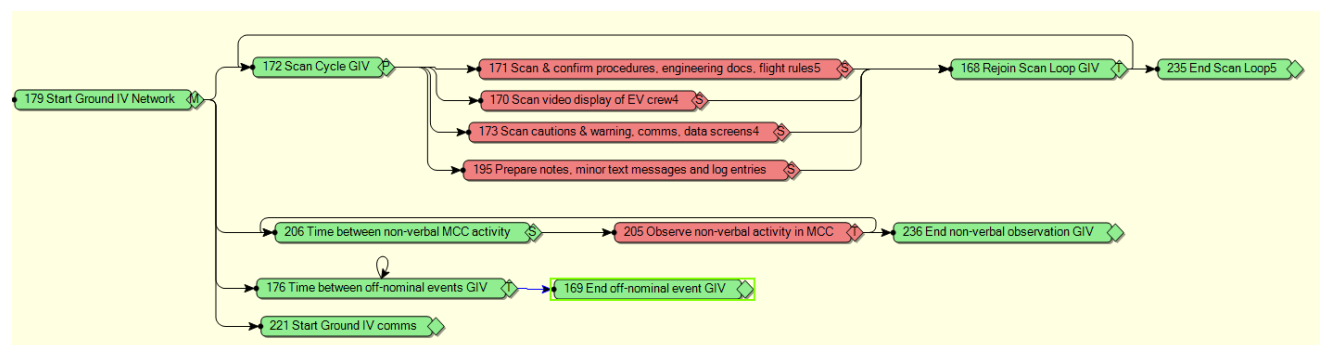
Depending on the nature of the off-nominal condition, one of the three following responses is made:

**Table 5. Off-Nominal Tasks for Ground IV Position**

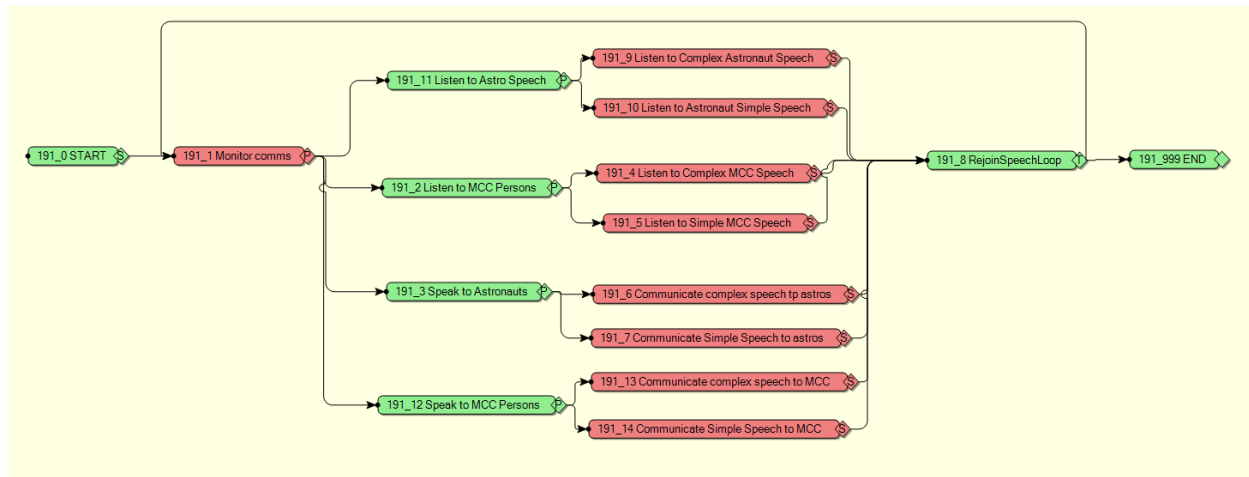
Off-nominal situation		Estimated Average frequency	Estimated average duration (seconds)
One of three possible responses to off-nominal:	1. Rapidly apply a prepared decision	Ev 45 min	5
	2. Decide action after referring to crib sheet, flight rules, or other document	Ev 2.5 hr	10
	3. Complex problem requires coordination with other MCC personnel	Ev 5 hr	10

## Ground IV Model and Results for ISS EVA

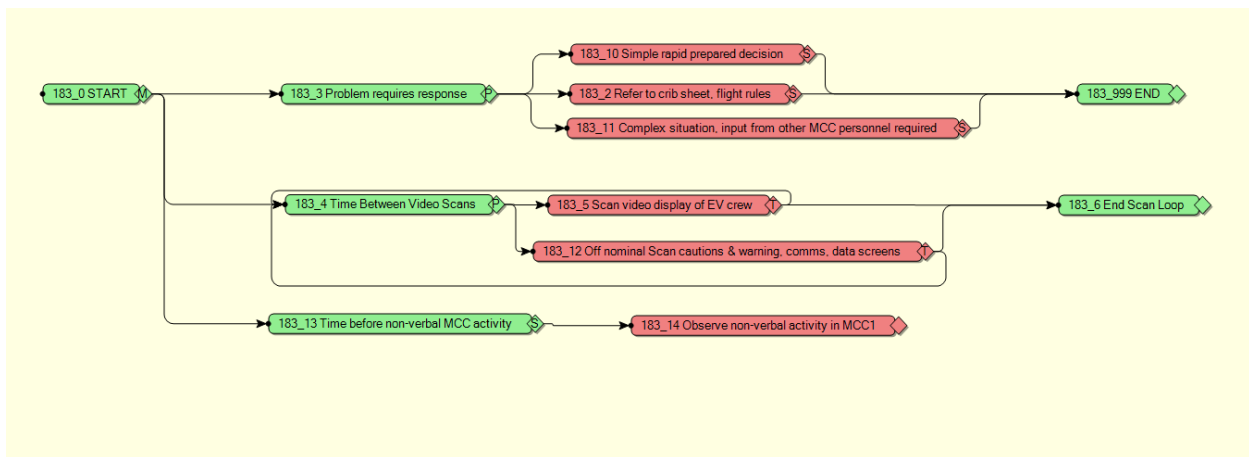
The task model for Ground IV contained three sections, shown below. These are nominal tasks (shown in Figure 22), communication tasks (Figure 23), and tasks that would be performed during an off-nominal event (Figure 24). During an off-nominal event, communication tasks continue, however the nominal tasks shown in Figure 22 are paused and are replaced by the off-nominal tasks shown in Figure 24.



**Figure 22. Ground IV Nominal Tasks**



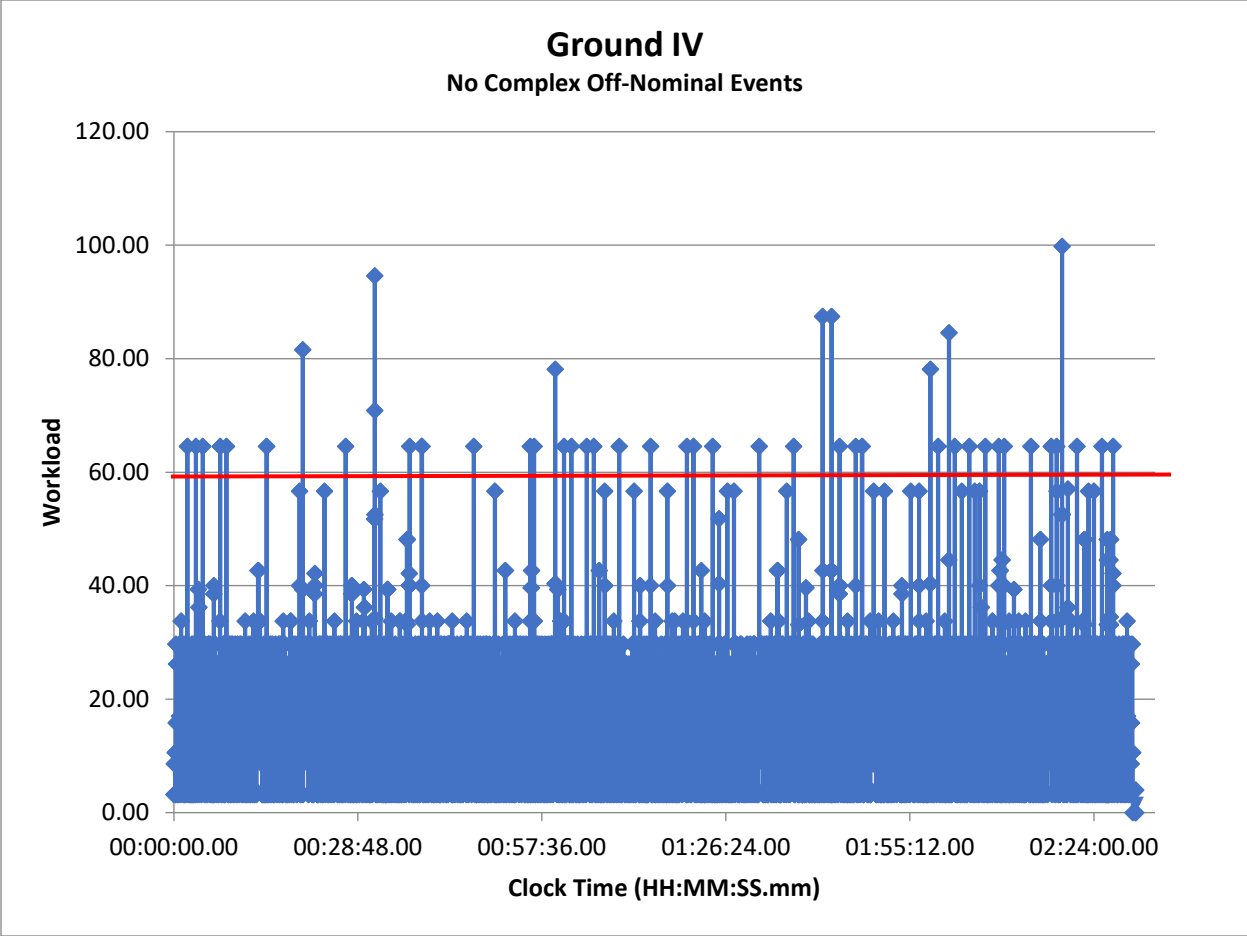
**Figure 23. Ground IV Communication Tasks**



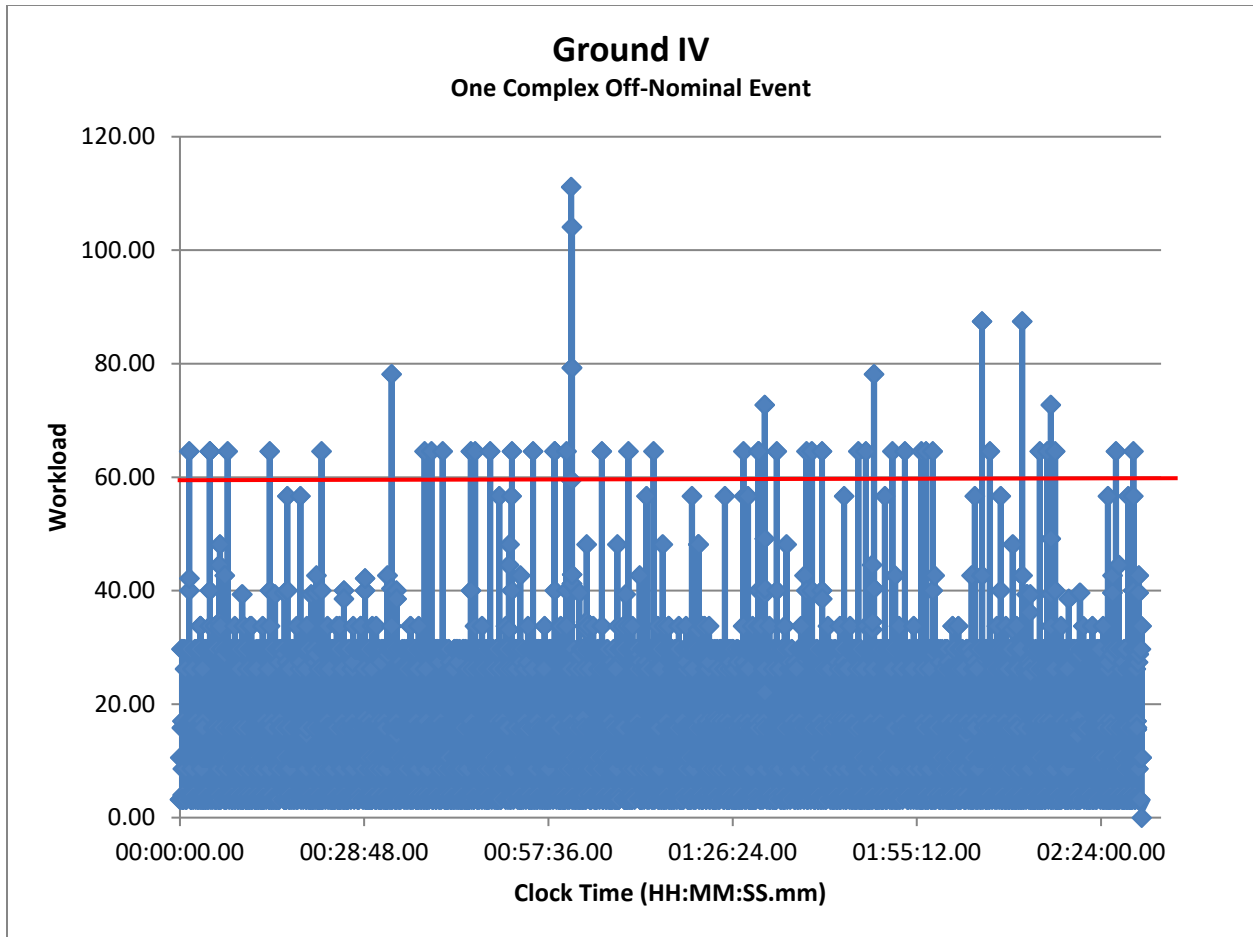
**Figure 24. Ground IV Off-nominal Tasks**

Figure 25 presents model output for Ground IV workload for a 2.5-hour period of an ISS EVA scenario generated by the IMPRINT model during which no complex off-nominal events occurred. Workload generally remained below the 60 threshold, apart from brief spikes.

Figure 26 presents Ground IV workload for a 2.5-hour period of an ISS EVA scenario generated by the IMPRINT model during which one complex off-nominal event occurred. The workload spike is brief, reflecting that the Ground IV was aware of the problem but was not actively working on a solution, and continued to act as an intermediary between the EV crew and the MCC.



*Figure 25. Ground IV Workload with no Complex Off-nominal Events*



**Figure 26. Ground IV Workload with One Complex Off-nominal Event**

Table 6 presents workload metrics produced by IMPRINT for the two scenarios shown in Figures 30 and 31. Overall workload for the Ground IV position remained in the “acceptable” range during these runs.

**Table 6. Ground IV Position Workload Metrics for 2.5-hour Period of an ISS EVA**

	Time-Avg Workload	Percent Time in Overload	Peak Workload
No Complex Off-Nominal Events	16.43	0.86	99.88
One Complex Off-Nominal Event	16.73	0.75	111.15

### **EVA Flight Controller**

The EVA flight controller is responsible for all EMU, Airlock, and EVA-related tasks, equipment and plans when an EVA takes place from the ISS. The EVA flight controller is located in the FCR. The EVA flight controller considered that her workload can be very demanding at times and that EVA flight controllers “work at the edge of human brain capacity sometimes.” The EVA flight controller must maintain a mental picture of what is happening throughout the EVA and what is expected to occur next (see Table 7).



The EVA flight controller stated that she has six monitors in front of her showing screens of data and the timeline. Her main source of information during the EVA are helmet cams, although static cameras are also referred to. The EVA flight controller stated that she performs a rapid scan cycle, where around every 30 seconds she refers to the video display of the EV crew, performs a quick scan of data screens, including cautions and warnings, and also scans and confirms procedures or other documentation. In common with all flight controllers, she monitors multiple voice loops. Space-ground communications are set to the loudest volume.

The EVA flight controller also monitors body language within the MCC. Small non-verbal gestures (e.g., nods or facial expressions) can convey information that enables her to maintain a shared understanding of the activities occurring in the room. The importance of non-verbal cues became apparent during COVID, when masks obscured facial expressions.

An important role of the position during EVA 79 was to optimize the use of time and to enable as many tasks as possible to be completed. When things go smoothly, the planned tasks are completed, and the crew can move on to get-aheads. An EVA OJT position seated next to the EVA position provides support including updating the console log and monitoring communications.

The EVA flight controller stated that off-nominal events are not unusual during EVAs. Many off-nominals are familiar situations that can be responded to rapidly because the event has been planned and trained for. In other cases, there may be a need to discuss an issue among flight controllers and solve a problem.

**Table 7. Nominal Tasks for EVA Position**

	<b>Nominal Tasks for EVA Position</b>	<b>Estimated frequency</b>	<b>Estimated average duration (seconds)</b>
<b>Rapid scan cycle</b>	Scan video display of EV crew	Ev 30 sec	2
	Scan cautions & warning, comms, data screens	Ev 30 sec	2
	Scan & confirm procedures, engineering docs, flight rules	Ev 30 sec	5
<b>Slow task cycle</b>	Prepare notes and minor text messages ( <i>Assistant makes log entries</i> )	Ev 25 min	30
	Decide and prepare plan adjustment	Ev hour	300
<b>Monitor the room</b>	Observe or become aware of non-verbal activity in the MCC	Ev 1 min	2
<b>Speaking and listening</b>	Monitor comm loops	Constant	
	Pay attention to complex crewmember speech (sentences)	Ev 15 sec	7
	Pay attention to simple crewmember speech (one or two words)	Ev 60 sec	1
	Pay attention to complex MCC speech (sentences)	Ev 1.5 min	4
	Pay attention to simple MCC speech (one or two words)	Ev 45 sec	1
	Communicate complex speech to the MCC (sentences)	Ev 60 sec	6
	Communicate simple speech to the MCC (one or two words)	Ev 30 sec	1

## Off-nominal Tasks for EVA Position

For modeling purposes, it was assumed that the EVA flight controller would be faced with an off-nominal situation on average every 15 minutes, and that 70% of the time, the problem could be resolved by the rapid application of a prepared decision, 20% of the time it would be necessary to refer to a procedure or other document to determine the appropriate action, and the remaining 10% of off-nominals would require the EVA flight controller to prepare a procedure for a more complex situation. It was assumed that the EVA flight controller would become aware of off-nominals more frequently than would the flight director or Ground IV. This is because the EVA flight controller is working at a more detailed level, and some off-nominals would be resolved without the need to elevate them to the flight director or Ground IV.

During an off-nominal situation, the EVA flight controller continues to perform the tasks listed in Table 8, with the exception of the following tasks, which (for modeling purposes) are assumed to be briefly paused while the off-nominal is dealt with or performed as part of solution development.

- Scan and confirm procedures, engineering docs, flight rules
- Prepare notes and minor text messages (Assistant makes log entries)
- Decide and prepare plan adjustment

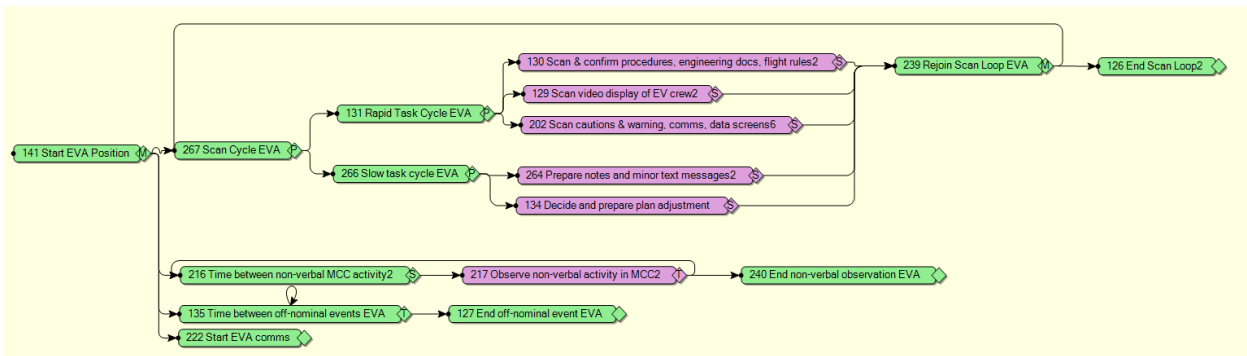
Depending on the nature of the off-nominal condition, one of the three following responses is made:

**Table 8. Off-Nominal Tasks for EVA Position**

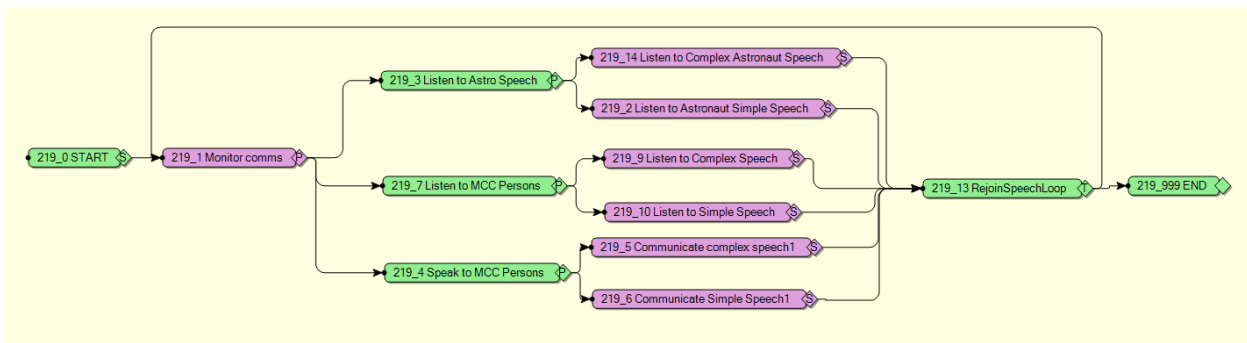
Off-nominal situation		Average frequency	Estimated Average Duration (seconds)
One of three possible responses to off-nominal:	1. Rapidly apply a prepared decision	Ev 20 min	5
	2. Decide action after referring to crib sheet, flight rules, or other document	Ev 75 min	300
	3. Decide on response to a complex off-nominal	Ev 2.5 hr	600

## EVA Model and Results for ISS EVA

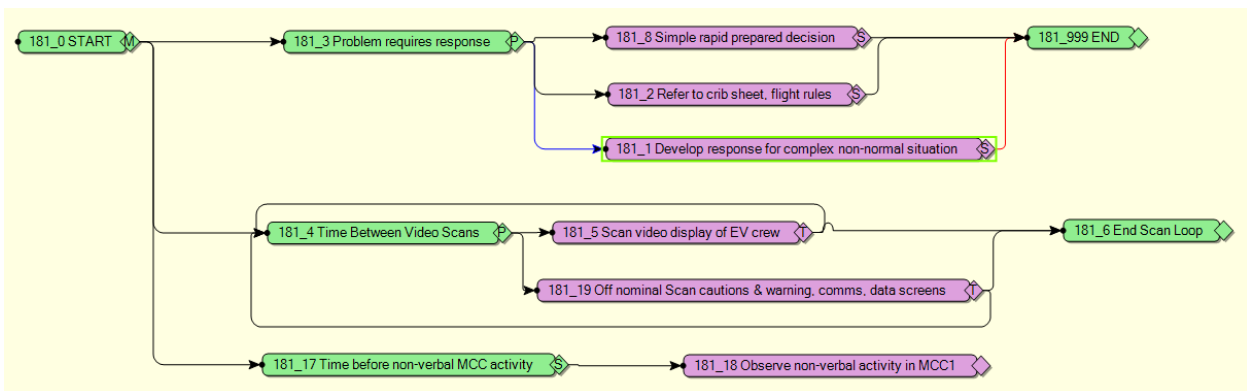
The task model for the EVA flight controller contained three sections, shown below. These are nominal tasks (shown in Figure 27), communication tasks (Figure 28), and tasks that would be performed during an off-nominal event (Figure 29). During an off-nominal event, communication tasks continue, however the nominal tasks shown in Figure 27 are paused and are replaced by the off-nominal tasks shown in Figure 29.



**Figure 27. EVA Flight Controller Nominal Tasks**



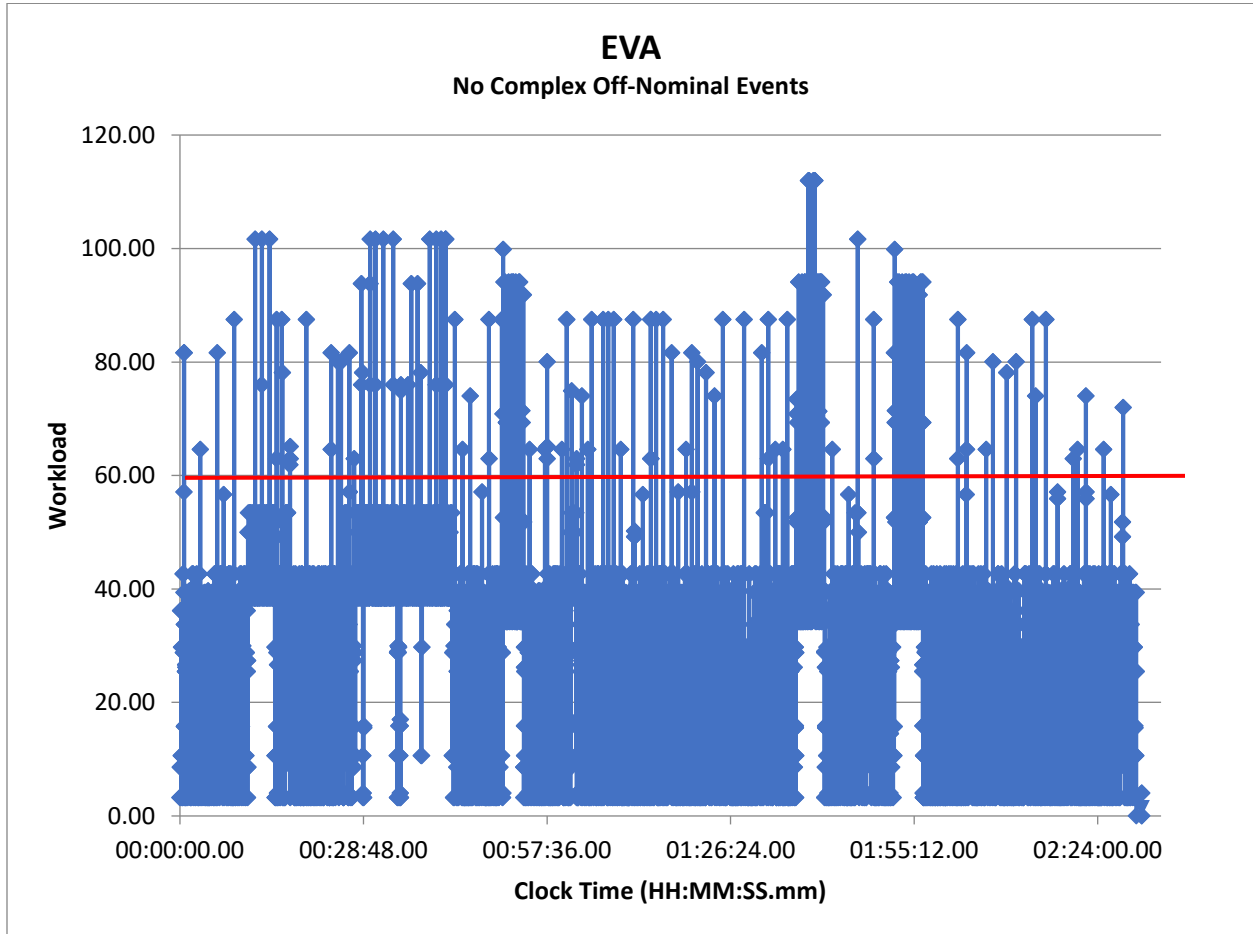
**Figure 28. EVA Flight Controller Communication Tasks**



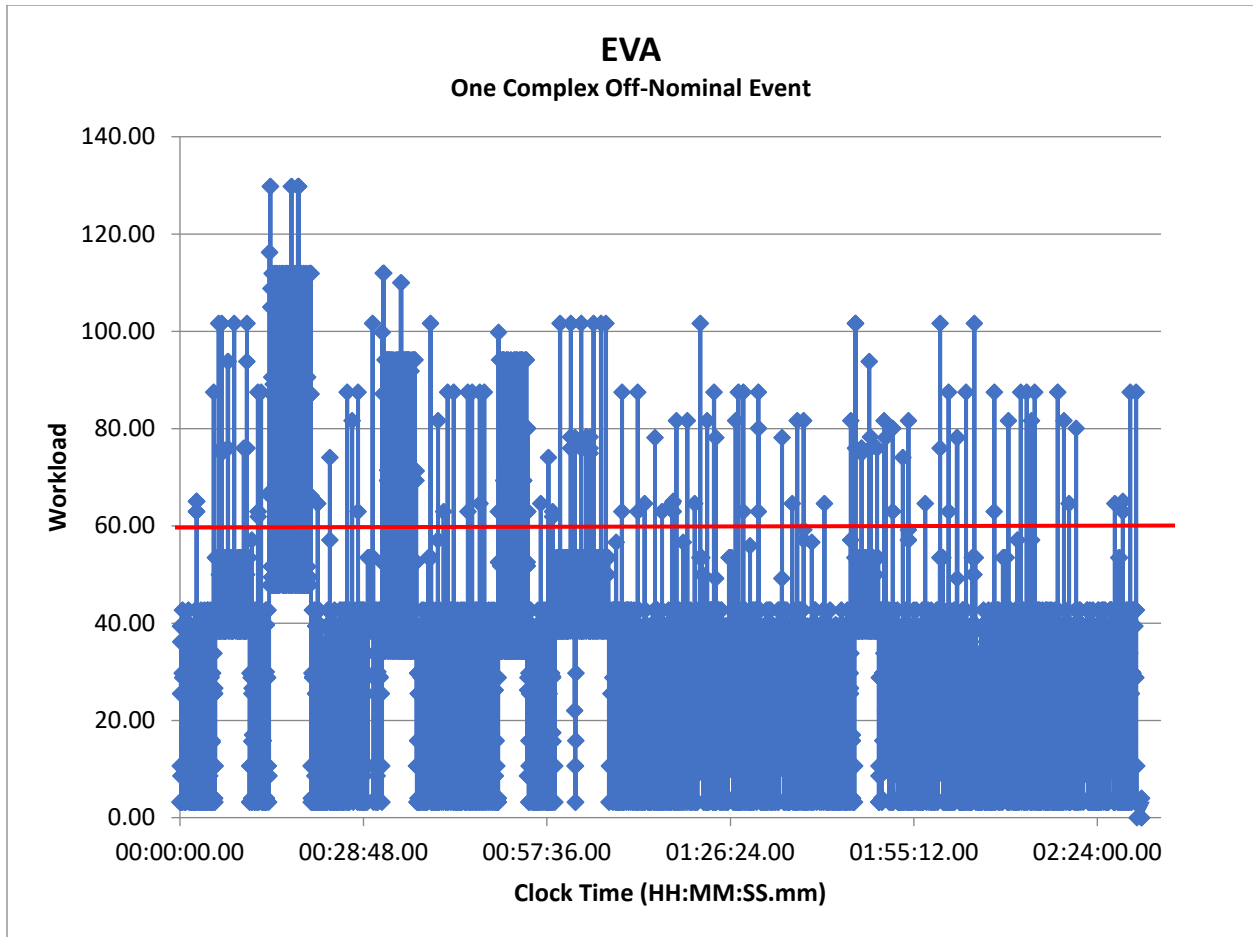
**Figure 29. EVA Flight Controller Off-nominal Tasks**

Figure 30 shows model output for EVA flight controller workload over a 2.5-hour period of an ISS EVA scenario generated by the IMPRINT model during which no complex off-nominal events occurred. Workload was regularly expected to be above the 60 threshold. The high peak of workload at 1:38.34 represents an off-nominal that was not considered complex, but required reference to crib sheets or flight rules. During that peak, the model predicted that the EVA flight controller would also be listening to complex crewmember speech, while simultaneously scanning cautions and warnings.

Figure 131 presents estimated EVA flight controller workload for a 2.5-hour period of an ISS EVA scenario generated by the IMPRINT model during which a complex off-nominal occurred within the first 30 minutes. Two additional off-nominals that could be resolved by reference to crib sheets, flight rules, or other documents occurred at around the 30-minute and 55-minute clock time.



*Figure 30. EVA Position Workload with no Complex Off-nominal Events*



**Figure 31. EVA Position Workload with One Complex Off-nominal Event**

Table 9 presents workload metrics produced by IMPRINT for the two scenarios shown in Figures 30 and 31. Overall workload for the EVA position was “high” during these runs.

**Table 9. EVA Position Workload Metrics for 2.5-hour Period of an ISS EVA**

	Time-Avg Workload	Percent Time in Overload	Peak Workload
<b>No Complex off-Nominal Events</b>	26.51	3.02	111.95
<b>One Complex Off-Nominal Event</b>	28.75	6.14	150.99

### EVA Task Flight Controller

The EVA Task flight controller (EVA Task) is located in the MPSR. They report to the EVA flight controller. EVA Task supports all task related activities during the EVA and is also responsible for crew and vehicle safety during EVA task operations. EVA Task monitors the progress of tasks at a high level of detail, including bolt turns and torque settings, and maintains awareness of crew safety, hardware constraints, and cautions and warnings. EVA Task follows task performance using paper procedures and draws an up arrow each time a command has been sent up, and crosses off each task as it is completed. When the crewmembers are speaking

everyone else's conversation tends to stop, but sometimes EVA Task has to do other tasks while they are talking. EVA Task tracks hardware to ensure that equipment is left in a safe state and ensures that tools are accounted for.

Currently they only plan to perform tasks that have been analyzed in advance. If you go "off script" you need the flight director to agree before non-analyzed tasks or configurations occur.

As the task progresses, she coordinates with flight controllers in the FCR and personnel in the MER. This includes equipment manufacturers, specialist engineering personnel and with flight controllers whose area of responsibility may be affected by the task being performed. For each ISS EVA, the MCC will contain a mix of full-time personnel (e.g., flight director, Ground IV) and specialists who have been brought in with specific task-related expertise.

The EVA Task flight controller prepares potential timelines in advance that can be updated and distributed when necessary. She has an automated tool to show progress against timelines, but she said that it is often easier to do these calculations mentally. She prepares timelines in Excel® and then sends out updated timelines when necessary. Starting at the beginning of the EVA, EVA Task is considering what get-aheads may be achievable, and in what order they should be performed. Part of her job is to knit together standalone procedures to get-aheads and monitor when estimates of time are correct and if necessary, to replan. An EVA that proceeds efficiently (e.g., EVA 79) can (somewhat counterintuitively) lead to increased workload for EVA Task, because the EV crew are able to move on to get-aheads, and therefore may be performing tasks that were not core objectives of the EVA.

EVA Task needs to deal with unplanned events as they occur. She relies on documents including crib sheets for possible failures, but crib sheets do not cover every eventuality. When the crib sheet does not cover an eventuality, she needs to prepare instructions that the Ground IV will read to the EV crew. For example, she thinks ahead to the actions that would be needed if the EVA needed to be terminated during a rapid abort or during a slower termination.

An EVA Task OJT position seated next to EVA Task provides support. This support includes updating the console log, monitoring task progress, checking the tools inventory, watching video of crew actions, and listening to voice loops, particularly the space-ground loop. It was noted that when crewmembers are speaking, personnel in the MCC generally remain quiet. If EVA Task is task saturated, the OJT can maintain awareness of the crew's actions and provide a situational update when needed. EVA Task OJT mentioned that he monitors video of the FCR, and this can be useful because it can tell you not to interrupt someone if you can see they're having an airwaves conversation.

**Table 10. Nominal Tasks for EVA Task Position**

	<b>Nominal tasks for EVA Task Position</b>	<b>Estimated frequency</b>	<b>Estimated average duration (seconds)</b>
<b>Rapid scan cycle</b>	Scan video display of EV crew	Ev 10 sec	2
	Scan & confirm procedures, engineering docs, flight rules	Ev 10 sec	2
<b>Slow task cycle</b>	Prepare notes and minor messages ( <i>Assistant makes log entries</i> )	Ev 30 min	300
	Decide and prepare plan adjustment	Ev 30 min	10
	Check progress, tools inventory, review and update timeline	Ev 20 min	60
	Scan cautions & warning, comms, data screens	Ev 30 min	5
<b>Monitor the room</b>	Observe or become aware of non-verbal activity in the MCC	Ev 1 min	2
<b>Speaking and listening</b>	Monitor comm loops	Constant	
	Pay attention to complex crewmember speech (sentences)	Ev 15 sec	7
	Pay attention to simple crewmember speech (one or two words)	Ev 1 min	1
	Pay attention to complex MCC speech (sentences)	Ev 90 sec	4
	Pay attention to simple MCC speech (one or two words)	Ev 1 min	1
	Communicate complex speech to the MCC (sentences)	Ev 1 min	6
	Communicate simple speech to the MCC (one or two words)	Ev 90 sec	2



## Off-nominal Tasks for EVA Task Position

For modeling purposes, it was assumed that EVA Task flight controller would be faced with an off-nominal situation on average every 15 minutes, and that 70% of the time, the problem could be resolved by the rapid application of a prepared decision, 20% of the time it would be necessary to refer to a procedure or other document to determine the appropriate action, and the remaining 10% of off-nominals would require the EVA Task flight controller to prepare a procedure for a more complex situation.

During an off-nominal situation, the EVA Task flight controller continues to perform the tasks listed in Table 10 above, with the exception of the following tasks, which (for modeling purposes) are assumed to be briefly paused while off-nominal is dealt with or performed as part of solution development.

- Scan and confirm procedures, engineering docs, flight rules
- Prepare notes and minor text messages (Assistant makes log entries)
- Decide and prepare plan adjustment
- Check progress, tools inventory, review and update timeline

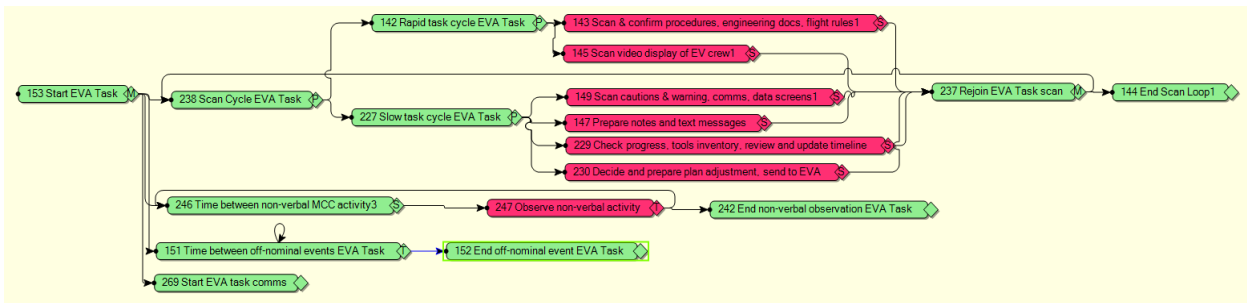
Depending on the nature of the off-nominal condition, one of the three following responses is made:

**Table 11. Off-Nominal Tasks for EVA Task Position**

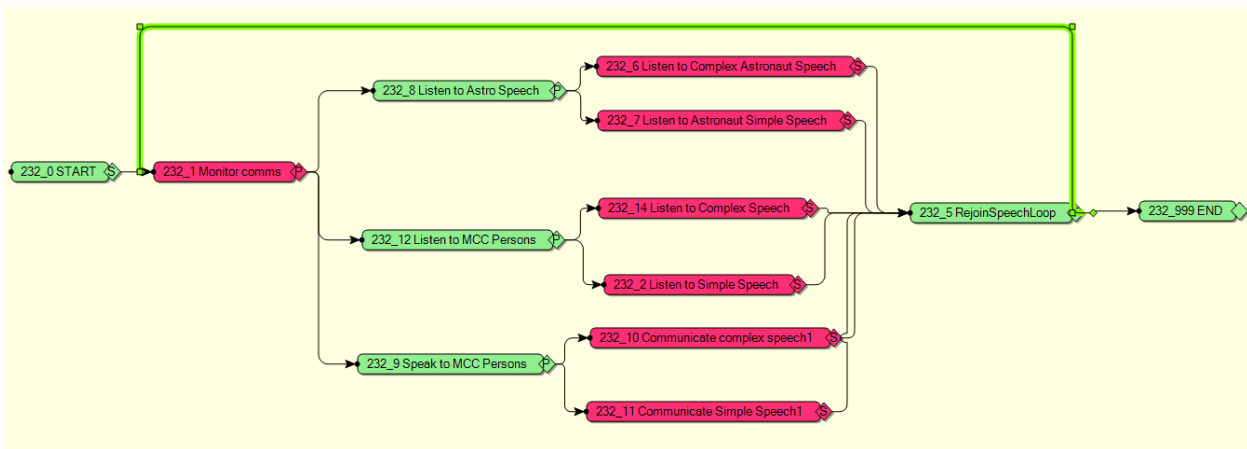
Off-nominal situation		Average frequency	Estimated average duration (seconds)
One of three possible responses to off-nominal:	1. Rapidly apply a prepared decision	Ev 20 min	5
	2. Decide action after referring to crib sheet, flight rules, or other document	Ev 75 min	300
	3. Prepare procedure for complex off-nominal	Ev 2.5 hr	1800

## EVA Task Model and Results for ISS EVA

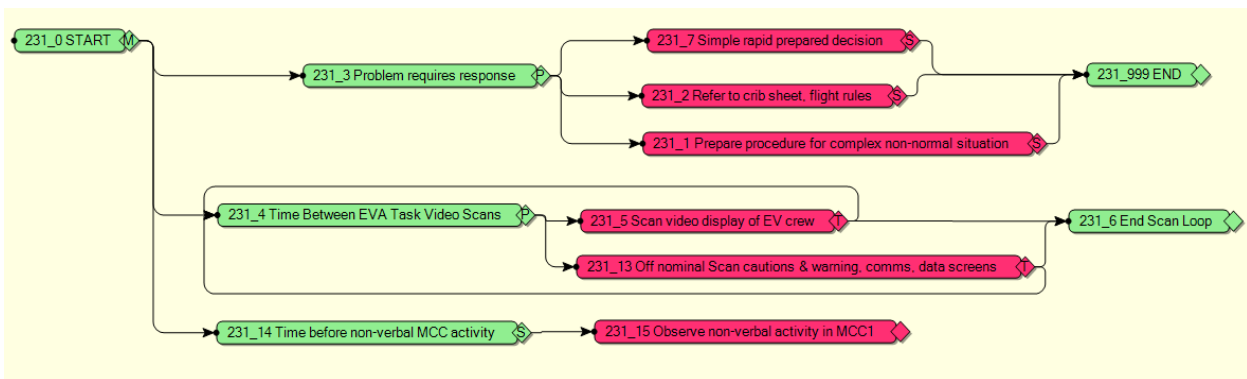
The task model for the EVA task flight controller contained three sections, shown below. These are nominal tasks (shown in Figure 32), communication tasks (Figure 33), and tasks that would be performed during an off-nominal event (Figure 34). During an off-nominal event, communication tasks continue, however the nominal tasks shown in Figure 32 are paused and are replaced by the off-nominal tasks shown in Figure 34.



**Figure 32. EVA Task Flight Controller Nominal Tasks**

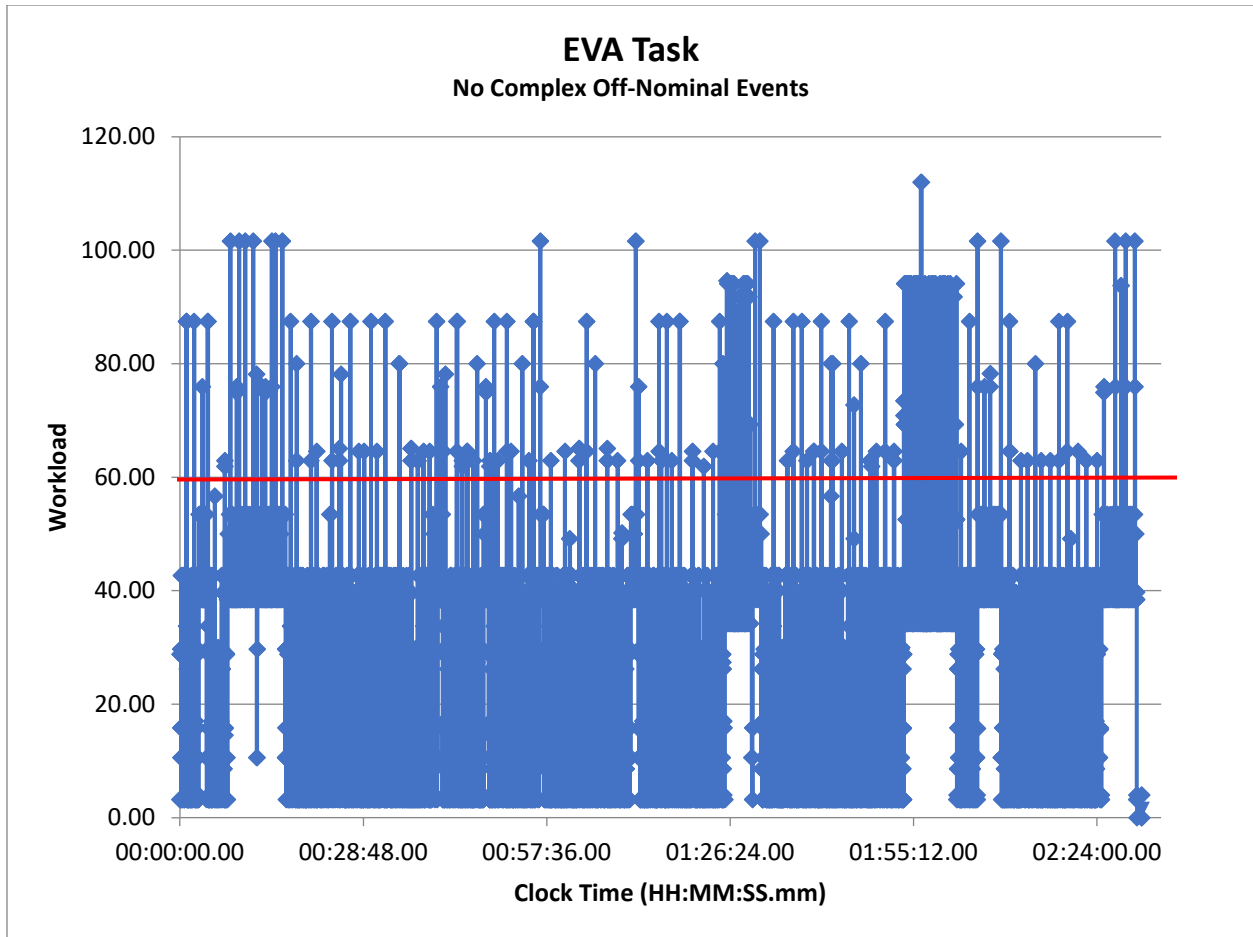


**Figure 33. EVA Task Flight Controller Communication Tasks**



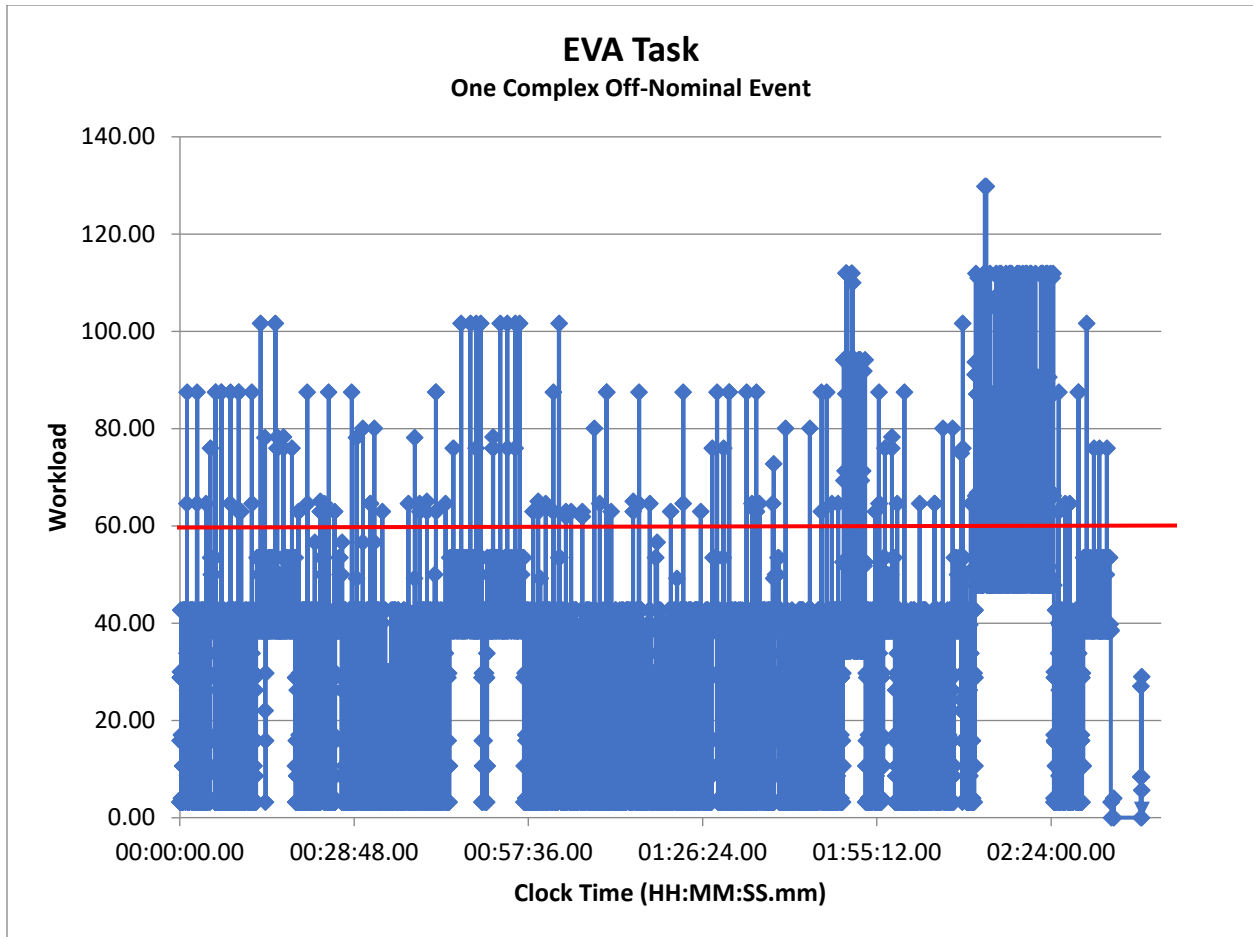
**Figure 34. EVA Task Flight Controller Off-nominal Tasks**

Figure 35 shows model output for EVA Task flight controller workload over a 2.5-hour period of an ISS EVA scenario generated by the IMPRINT model during which no complex off-nominal events occurred. As might be expected for a technical EVA involving an assembly task, workload frequently exceeded the 60 threshold.



***Figure 35. EVA Task Position Workload with no Complex Off-nominal Events***

Figure 36 shows model output for EVA Task flight controller workload over a 2.5-hour period of an ISS EVA scenario generated by the IMPRINT model during a complex off-nominal event occurred. The off-nominal (at around 2:10) produced a sustained peak in workload. It would be expected that EVA Task would need to shed some tasks while the off-nominal situation was dealt with.



**Figure 36. EVA Task Position Workload with One Complex Off-nominal Event**

Table 12 presents workload metrics produced by IMPRINT for the two scenarios shown in Figures 35 and 36. Overall workload for the EVA Task position was estimated to “high” regardless of whether a complex off-nominal event occurred.

**Table 12. EVA Task Position Workload Metrics for 2.5-hour Period of an ISS EVA**

	Time-Avg Workload	Percent Time in Overload	Peak Workload
No Complex Off-Nominal Events	28.55	3.43	111.95
One Complex Off-Nominal Event	30.25	6.81	129.76

### EMU Flight Controller (EVA Systems)

The EMU flight controller (also referred to as EVA Systems) is a MPSR position, co-located with EVA TASK and AIRLOCK. The EMU flight controller monitors and configures the EMU, troubleshoots EMU problems when necessary, and provides reports on systems status and consumables to the EVA position. The challenges of each EVA can differ greatly depending on

the nature of the task; however, similar EMU considerations tend to apply regardless of the purpose of the EVA.

The EMU SME reported that he constantly monitors video displays, and listens to around 15 flight loops, the most critical being flight director and Space Ground, and the communication loop with the EVA position.

Calculating time remaining on consumables is a key task. The EMU SME reported that he uses a spreadsheet to calculate time remaining in EVA. If a sensor fails, the spreadsheet provides a backup, enabling him to extrapolate. He has a flight rules table that shows how long consumables will last, and that can give an idea of when it will be necessary to return to the airlock.

Every 2 minutes there is a data pass from the suits via UHF. If something is off-nominal, he will wait for the next update in 2 minutes, to see if it is a genuine reading or a spurious data spike. Each suit has a history, and some have known quirks (e.g., a tendency to give low or high telemetry readings). The EMU flight controller is aware of each suit's characteristics and this assists in interpreting suit telemetry.

He will also sometimes perform quick calculations on the status of consumables. During nominal operations, he will report the status of consumables to the EVA position about once per hour.

Most EMU failures would result in a need to terminate the EVA. The more serious the problem, the more rapidly the EV crew will need to return to the airlock. During EVA 79 a fire indication occurred on the ISS. This indication turned out to be false; however, the EMU flight controller referred to flight rules to prepare a response and coordinate with EVA and ETHOS (life support) in preparation for airlock entry.

The EMU flight controller estimated that there would be two or three occasions each EVA where there was a need to diagnose an off-nominal event, and that, on average, they might encounter one event per EVA that would require them to prepare a procedure for a complex off-nominal. For modeling purposes, it was assumed that an off-nominal would occur on average every 30 minutes, and that 70% of the time, the problem could be resolved by the rapid application of a prepared decision, 20% of the time it would be necessary to refer to a procedure or other document to determine the appropriate action, and the remaining 10% of off-nominals would require EMU flight controller to prepare a procedure for a more complex situation.

**Table 13. Nominal Tasks for EMU Position**

	<b>Nominal tasks for EMU Position</b>	<b>Estimated frequency</b>	<b>Estimated average duration (seconds)</b>
<b>Rapid task cycle</b>	Scan video display of EV crew	10 sec	2
<b>Slow task cycle</b>	Scan data screen, including cautions and warnings, communications displays	2 min	10
	Prepare flight note, text message, or log entry	5 min	10
	Calculate status of consumables	9 min	10
	Calculate end time for EVA	60 min	60
	Glove and Helmet Absorption Pad (HAP) check	90 min	15
<b>Monitor the room</b>	Observe or become aware of non-verbal activity in the MCC	1 min	2
<b>Speaking and listening</b>	Monitor comm loops	Constant	
	Pay attention to complex crewmember speech (sentences)	15 sec	7
	Pay attention to simple crewmember speech (one or two words)	1 min	1
	Pay attention to complex MCC speech (sentences)	2 min	4
	Pay attention to simple MCC speech (one or two words)	1 min	1
	Communicate complex speech to the MCC (sentences)	20 min	6
	Communicate simple speech to the MCC (one or two words)	8 min	2

## Off-nominal Tasks for EMU Position

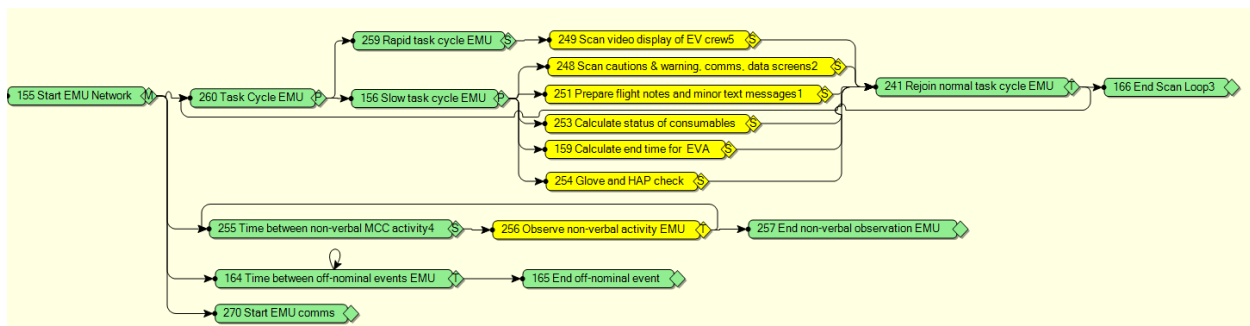
In contrast to other positions, the EMU flight controller did not shed tasks during off-nominal situations. In addition to the tasks shown in Table 13 above, one of the three following responses is made during the off-nominal situation:

**Table 14. Off-Nominal Tasks for EMU Position**

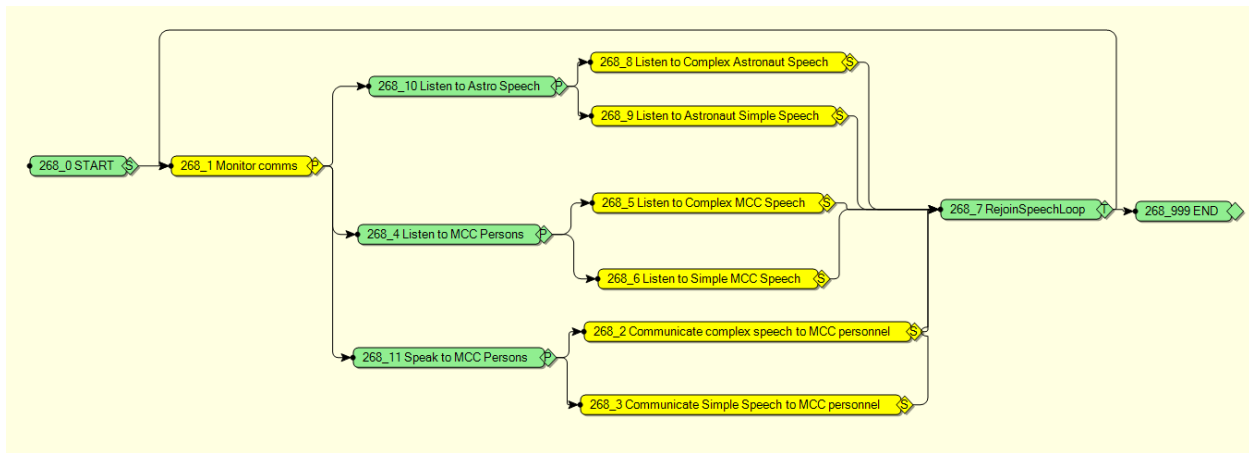
Off-nominal situation	Average frequency	Estimated average duration (seconds)
One of three possible responses to off-nominal:	1. Straightforward rapid response	Ev 30 min
	2. Decide action after referring to crib sheet, flight rules, or other document	Ev 2.5 hr
	3. Prepare procedure for complex off-nominal	Ev 6 hr

## EMU Model and Results

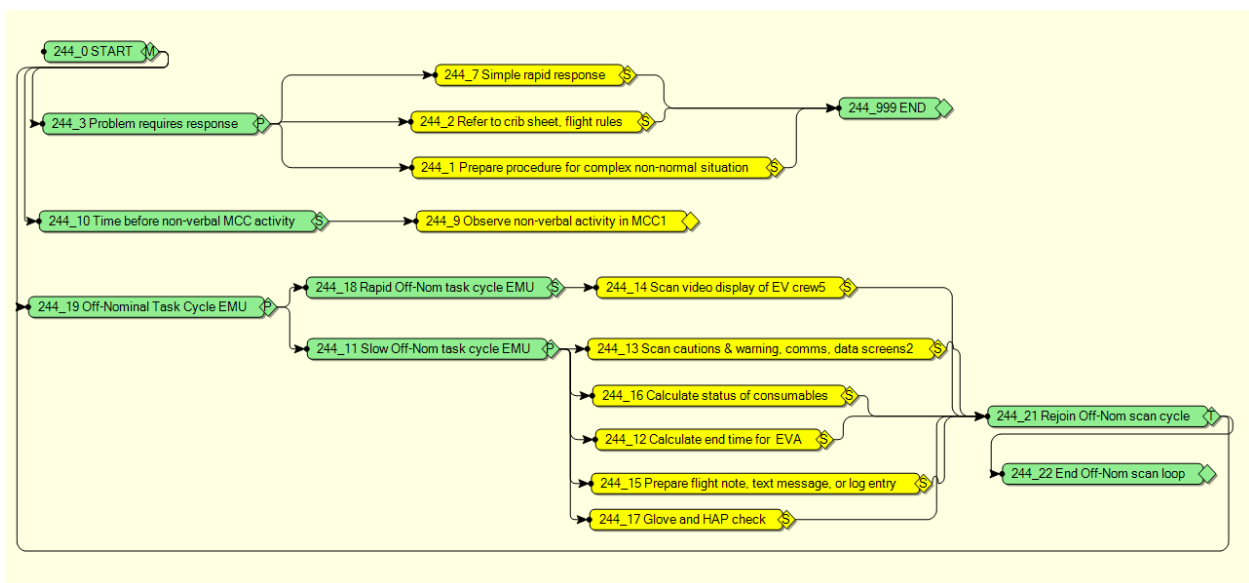
The task model for the EMU flight controller contained three sections, shown below. These are nominal tasks (shown in Figure 37), communication tasks (Figure 38), and tasks that would be performed during an off-nominal event (Figure 39). During an off-nominal event, communication tasks continue, however the nominal tasks shown in Figure 37 are paused and replaced by the off-nominal tasks shown in Figure 39.



**Figure 37. EMU Flight Controller Nominal Tasks**



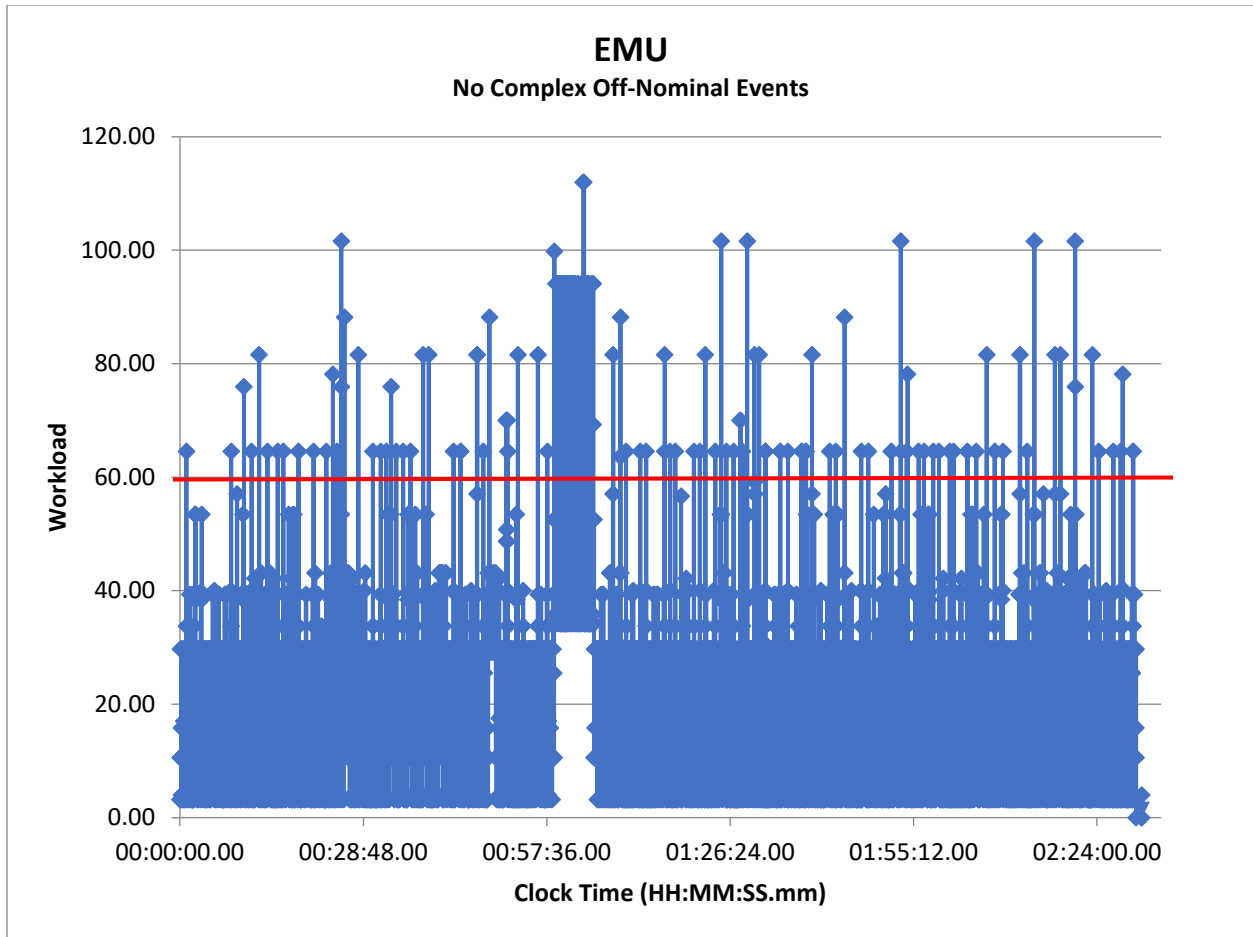
**Figure 38. EMU Flight Controller Communication Tasks**



**Figure 39. EMU Flight Controller Off-nominal Tasks**

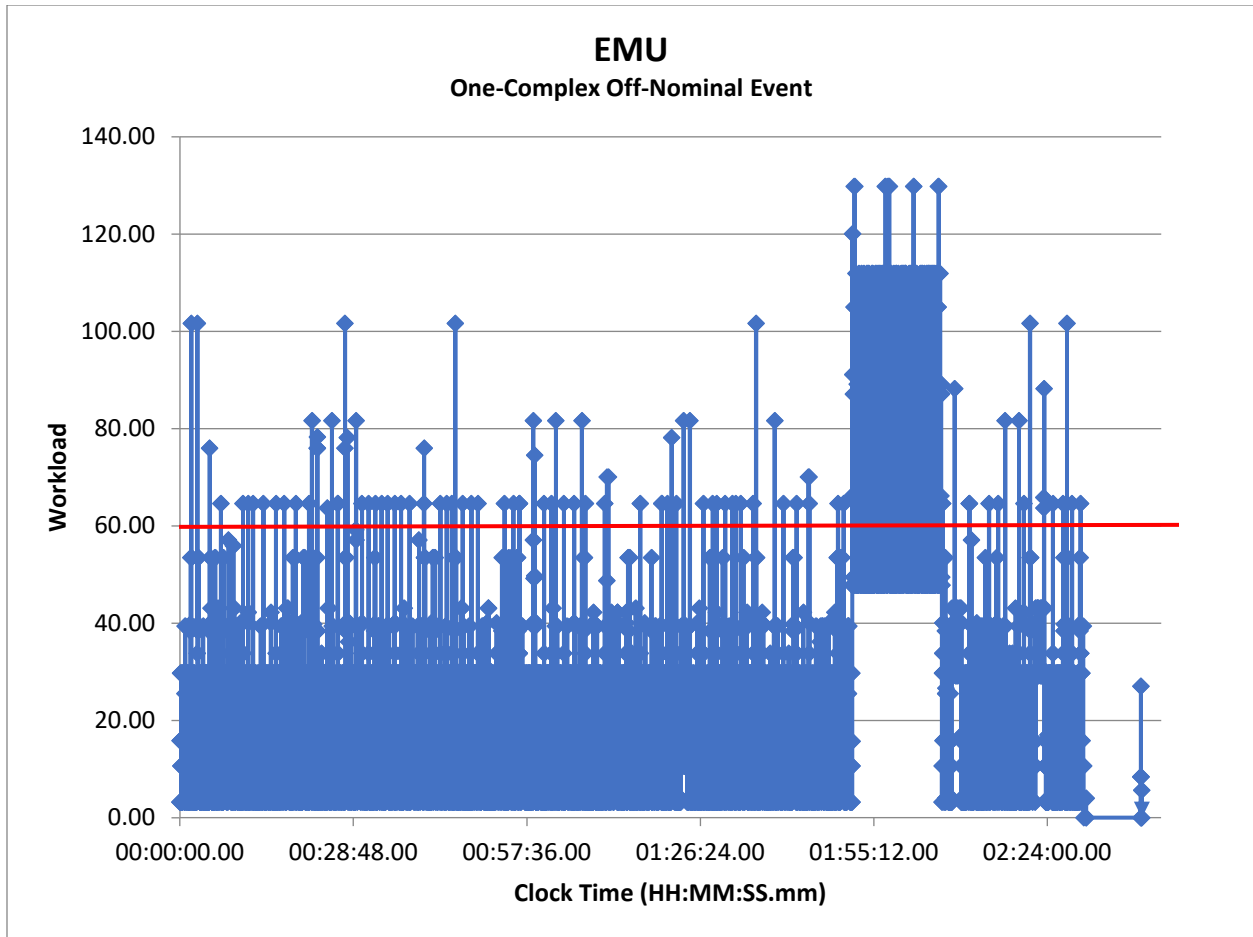
Figure 40 shows model output for EMU flight controller workload over a 2.5-hour period of an ISS EVA scenario generated by the IMPRINT model during which no complex off-nominal events occurred. The peak in workload shown near the one-hour mark represents a non-complex off-nominal that required reference to a crib sheet, flight rule or other document, while the EMU officer was simultaneously listening to a complex communication from a crewmember, while also observing non-verbal activity in the MCC.





**Figure 40. EMU Position Workload with no Complex Off-nominal Events**

Figure 41 shows model output for EMU flight controller workload over a 2.5-hour period of an ISS EVA scenario generated by the IMPRINT model during which a complex off-nominal event occurred at around the 2-hour mark. The model predicted that this would produce a significant and sustained workload peak. It would be expected that the EMU officer would be task saturated at this point and would need to shed some tasks until the off-nominal situation was resolved.



**Figure 41. EMU Position Workload with one Complex Off-nominal Event**

Table 15 presents workload metrics produced by IMPRINT for the two scenarios shown in Figures 40 and 41. Overall workload for the EMU position was estimated to be in the “acceptable” range on the run without a complex off-nominal event, and in the “high” range on the run that involved a complex off-nominal event.

**Table 15. EMU Position Workload Metrics for 2.5-hour period of an ISS EVA**

	Time-Avg Workload	Percent Time in Overload	Peak Workload
No Complex Off-Nominal Events	22.96	2.12	111.95
One Complex Off-Nominal Event	24.72	7.56	129.76

### **Combined Positions**

To investigate the possibility of assigning MCC responsibilities for a future Mars mission to personnel who would be located in a vehicle orbiting the planet, the five MCC positions modeled up to this point were combined into two positions as follows. The tasks for the flight director and Ground IV were combined into a hypothetical flight director/IV position, and the roles of EVA, EVA Task, and EMU were combined into a hypothetical Combined EVA position.

In combining these positions, the following assumptions were made:

- No real-time communication would occur between these positions and MCC personnel on Earth.
- Compared to current MCC personnel, the combined positions would have significantly fewer people with whom to communicate, and therefore communication workload would be reduced.
- When a task that was performed at a different frequency by different MCC personnel was assigned to a hypothetical combined position, the highest frequency of task performance was entered into the model. (For example, if EMU and EVA Task scanned a video display every 10 seconds and EVA scanned it every 30 seconds, then the 10-second frequency would be used in the model for the combined EVA position.)
- Some form of recurring suit check similar to the current Glove and HAP checks would be necessary. For example, this may involve checks of gloves, boots, seals, or other features of the suit that may experience wear under Mars surface conditions.

### Combined Flight Director/IV

Tasks for the hypothetical combined flight director/IV position are shown in Table 16.

**Table 16. Nominal Tasks for Hypothetical Combined Flight Director/IV Position**

	<b>Nominal tasks for hypothetical combined Flight Director/IV Position</b>	<b>Estimated frequency</b>	<b>Estimated average duration (seconds)</b>
<b>Scan cycle</b>	Scan video display of EV crew	Ev 45 sec	30
	Scan data screen, including cautions and warnings, communications displays	Ev 25 min	10
<b>Documents</b>	Refer to procedures, timeline, engineering documents, flight rules	Ev 7.5 min	35
	Prepare flight note, text message, or log entry	Ev 10 min	30
	Decide on plan adjustment (e.g., which get-aheads to do, when to end)	Ev 2 hr	180
<b>Monitor the other Astro in vehicle</b>	Observe or become aware of non-verbal activity in vehicle	1 min	2
	Monitor comm loops	Constant	

	<b>Nominal tasks for hypothetical combined Flight Director/IV Position</b>	<b>Estimated frequency</b>	<b>Estimated average duration (seconds)</b>
<b>Speaking and listening</b>	Pay attention to complex crewmember speech (sentences)	Ev 15 sec	7
	Pay attention to simple crewmember speech (one or two words)	Ev 1 min	60
	Pay attention to complex EVA speech (sentences)	Ev 5 min	4
	Pay attention to simple EVA speech (one or two words)	Ev 2.5 min	1
	Communicate complex speech to EVA (sentences)	Ev 2.5 min	4
	Communicate simple speech to EVA (one or two words)	Ev 2 min	1
	Communicate complex speech to Crewmembers	Ev 1 min	8
	Communicate simple speech to Crewmembers	Ev 30 sec	1

### **Off-nominal Tasks for Hypothetical Combined Flight Director/IV Position**

During an off-nominal situation, the flight director/IV position would continue to perform the tasks listed in Table 17, with the exception of the following tasks, which (for modeling purposes) are assumed to be briefly paused while off-nominal is dealt with or performed as part of solution development.

- Refer to procedures, engineering documents, flight rules
- Prepare flight note, text message, or log entry

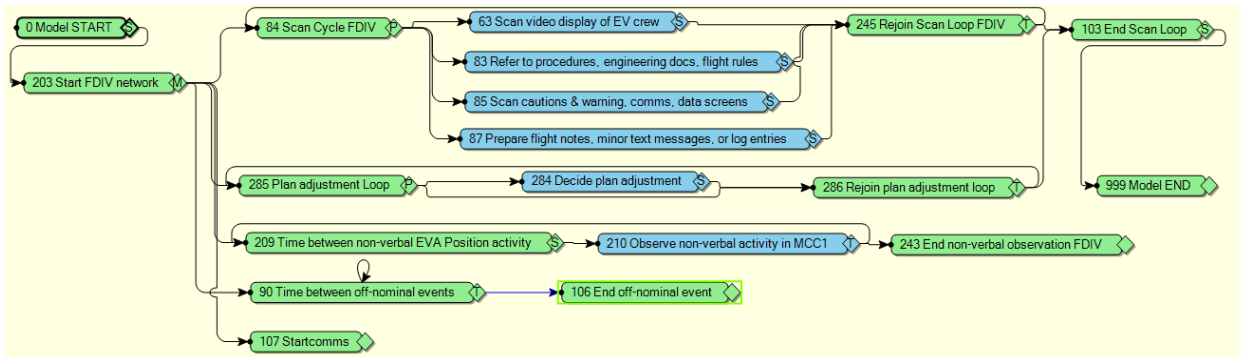
Depending on the nature of the off-nominal condition, one of the three following responses is made:

**Table 17. Off-Nominal Tasks for Hypothetical Combined Flight Director/IV Position**

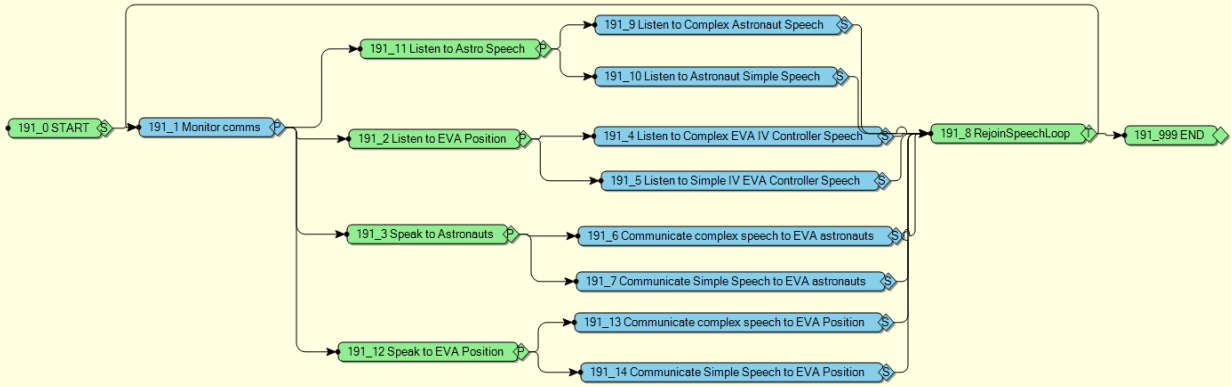
Off-nominal situation		Average frequency	Estimated average duration (seconds)
One of three possible responses to off-nominal:	1. Rapidly apply a prepared decision	Ev 45 min	5
	2. Decide action after referring to crib sheet, flight rules, or other document	Ev 2.5 hr	10
	3. Complex problem outside procedures requires solution	Ev 5 hr	300

### Combined Flight Director/IV Model and Results

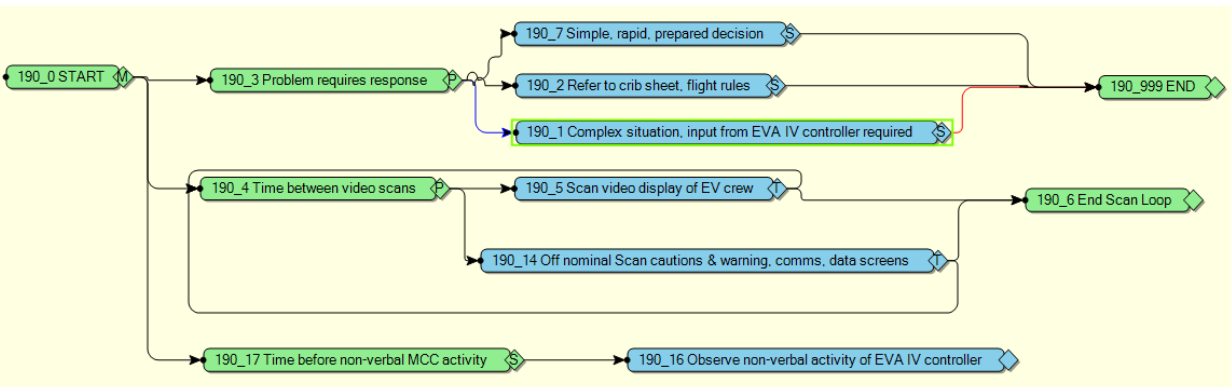
The task model for the hypothetical combined flight director/IV position contained three sections, shown below. These are nominal tasks (shown in Figure 42), communication tasks (Figure 43), and tasks that would be performed during an off-nominal event (Figure 44). During an off-nominal event, communication tasks continue, however the nominal tasks shown in Figure 42 are paused and are replaced by the off-nominal tasks shown in Figure 44.



**Figure 42. Nominal Tasks for Hypothetical Combined Flight Director/IV Position**

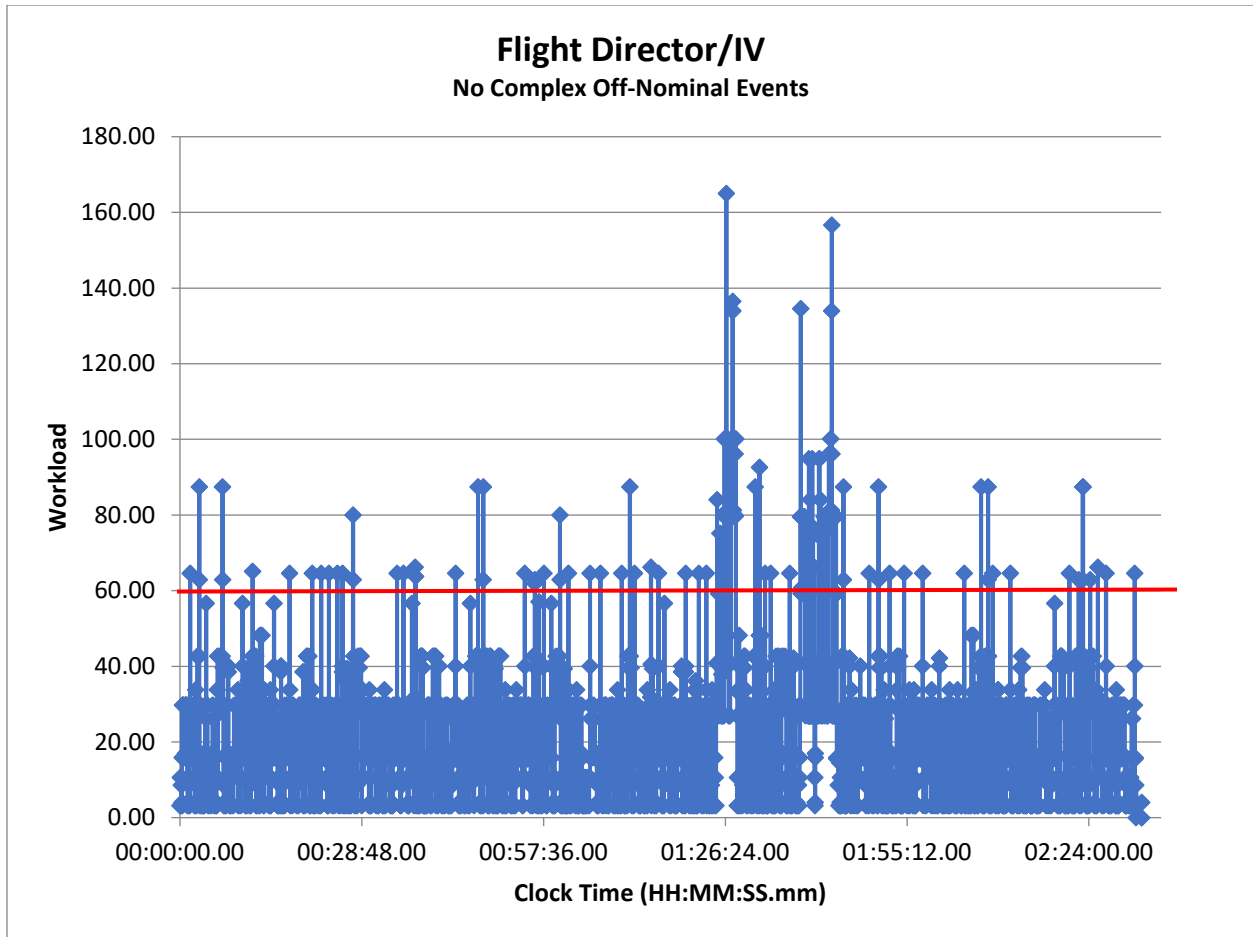


**Figure 43. Communication Tasks for Hypothetical Combined Flight Director/IV Position**



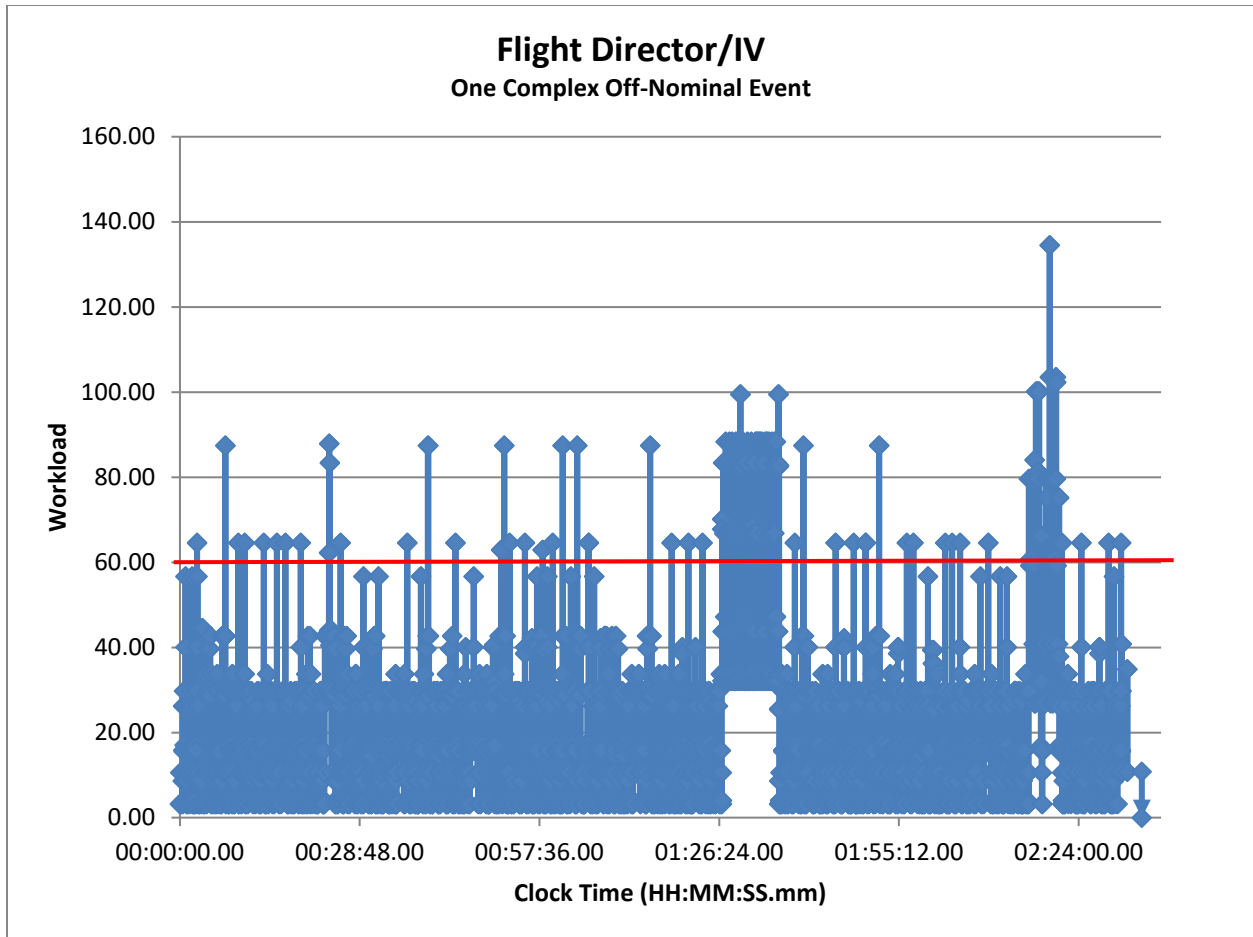
**Figure 44. Off-nominal Tasks for Hypothetical Combined Flight Director/IV Position**

Figure 45 displays predicted flight director/IV workload for a 2.5-hour period of a Mars Planetary Surface EVA during which no complex off-nominal events occurred. For most of this period, workload remained below the threshold of 60. Nevertheless, brief peaks of high workload are predicted. The highest workload peak, at around 1:30 occurs when the flight director/IV position is required to simultaneously decide on a plan adjustment, observe non-verbal activity from the EVA controller, refer to procedures, while also listening to complex speech from EV1 or EV2.



**Figure 45. Workload for a Combined Flight Director/IV Position with no Complex Off-Nominal Events**

Figure 46 displays predicted flight director/IV workload for a 2.5-hour period of a Mars Planetary Surface EVA during which a complex off-nominal events occurred at approximately 1:15. A period of workload with a value of below 90 occurs for around 6 minutes. During this time, the flight director/IV position is predicted to be dealing with a complex problem for which no proceduralized solution exists, while scanning the video display of the EV crew and listening to complex speech from EV1 or EV2.



**Figure 46. Workload for a Combined Flight Director/IV Position with one Complex Off-Nominal Events**

Table 18 presents workload metrics produced by IMPRINT for the two scenarios shown in Figures 45 and 46. The flight director/IV overall workload during the run without a complex off-nominal was in the “acceptable” range. The run with a complex off-nominal event produced an overall workload metric of “high”.

**Table 18. Combined Flight Director/IV Position Workload Metrics for 2.5-hour Period of a Hypothetical Mars EVA**

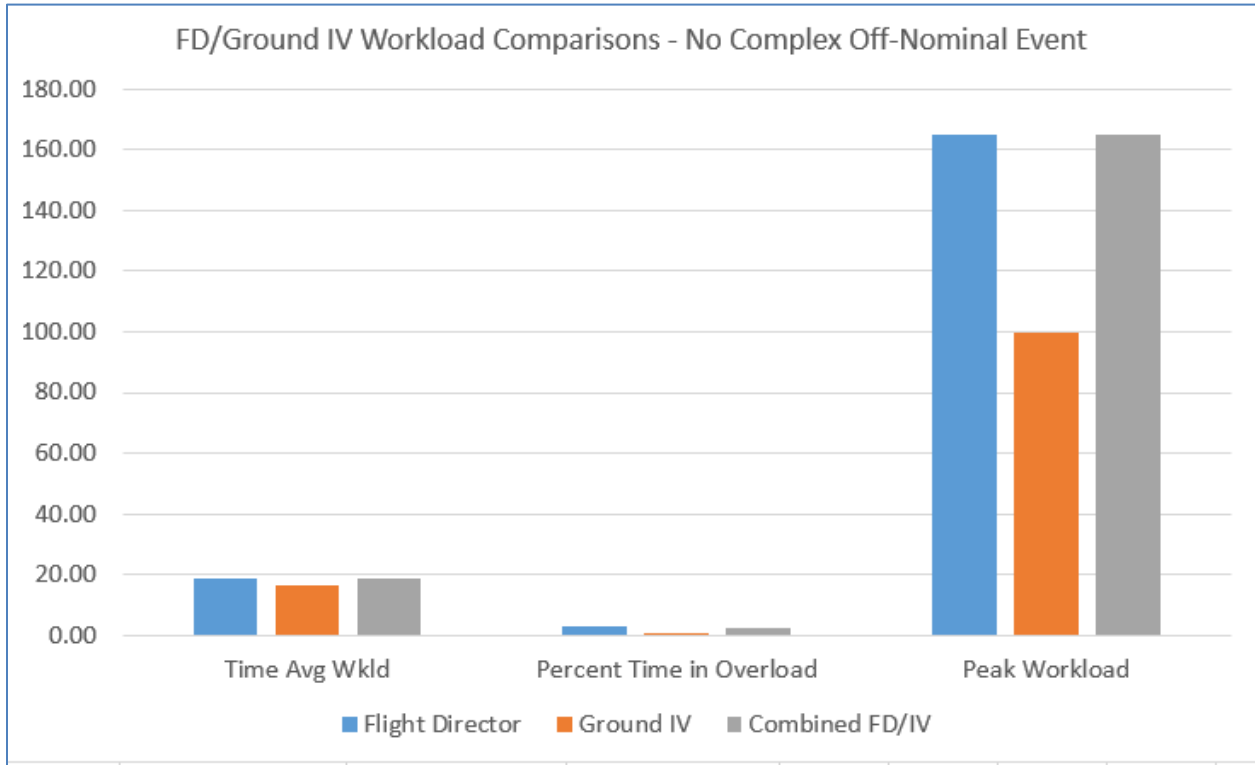
	Time-Avg Workload	Percent Time in Overload	Peak Workload
No Complex off-Nominal Events	18.93	2.16	164.97
One Complex Off-Nominal Event	20.80	3.50	134.25

**Comparison of Workload Estimates for Current Flight Director and Ground IV Positions vs Combined Position**

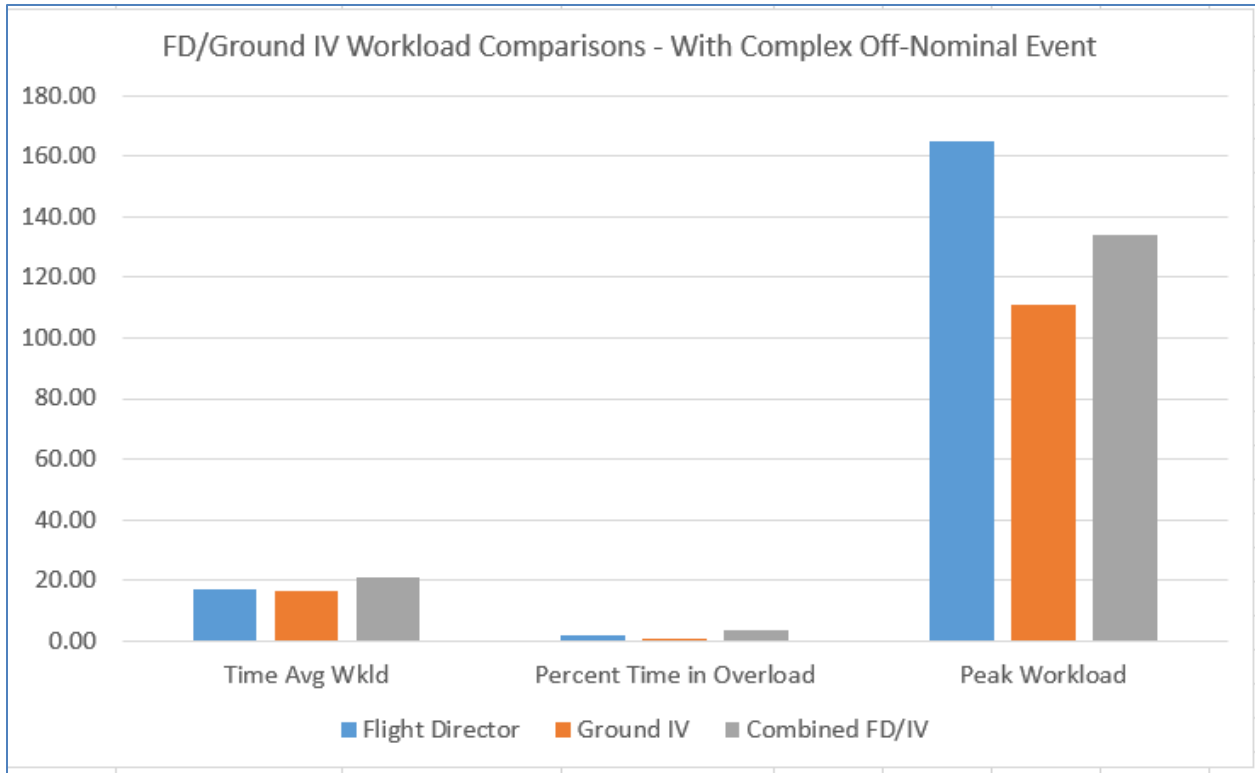
Figures 47 and 48 show workload metrics produced by the IMPRINT models for the current flight director and Ground IV positions, alongside the estimated workload for a hypothetical combined flight director/IV position performed from mars orbit. The results suggest that a



combined flight director/IV position would not produce a level of workload significantly different to that currently experienced by the flight director or Ground IV positions.



**Figure 47. Comparison of Workload for Hypothetical Combined Flight Director/IV Position with Current Flight Director and Ground IV Workload for EVAs with No Complex Off-nominal Events**



**Figure 48. Comparison of Workload for Hypothetical Combined Flight Director/IV Position with Current Flight Director and Ground IV Workload for EVAs with One Complex Off-nominal Event**

**Combined EVA, EVA Task, and EMU Positions**

Tasks for the hypothetical combined EVA, EVA Task, and EMU flight controller positions are shown in Table 19.

**Table 19. Combined EVA, EVA Task, and EMU Positions**

	Nominal tasks for hypothetical combined EVA, EVA Task & EMU Position	Estimated frequency	Estimated average duration (seconds)
<b>Rapid scan cycle</b>	Scan video display of EV crew	Ev 10 sec	2
	Scan & confirm procedures, engineering docs, flight rules	Ev 10 sec	2
<b>Slow task cycle</b>	Prepare notes and minor messages	Ev 30 min	300
	Decide and prepare plan adjustment	Ev 30 min	10
	Check progress, tools inventory, review and update timeline	Ev 20 min	60

	<b>Nominal tasks for hypothetical combined EVA, EVA Task &amp; EMU Position</b>	<b>Estimated frequency</b>	<b>Estimated average duration (seconds)</b>
	Scan cautions & warning, comms, data screens	Ev 30 sec	5
	Calculate status of consumables	Ev 9 min	10
	Calculate EVA end time	Ev 60 min	60
	Glove and HAP (or equivalent suit check)	Ev 90 min	15
<b>Monitor the room</b>	Observe or become aware of non-verbal activity in the MCC	Ev 1 min	2
<b>Speaking and listening</b>	Monitor comm loops	Constant	
	Pay attention to complex crewmember speech (sentences)	Ev 15 sec	7
	Pay attention to simple crewmember speech (one or two words)	Ev 60 sec	1
	Pay attention to complex flight director/IV speech (sentences)	Ev 150 sec	4
	Pay attention to simple flight director/IV speech (one or two words)	Ev 120 sec	1
	Communicate complex speech to flight director/IV (sentences)	Ev 5 min	6
	Communicate simple speech to flight director/IV (one or two words)	Ev 150 sec	2

### **Off-nominal Tasks for Hypothetical Combined EVA, EVA Task and EMU Position**

During an off-nominal situation, the Combined EVA position would continue to perform the tasks listed in Table 20, with the exception of the following tasks, which (for modeling purposes) are assumed to be briefly paused while off-nominal is dealt with or performed as part of solution development.

- Prepare notes and minor messages
- Decide and prepare plan adjustment
- Check progress, tools inventory, review and update timeline

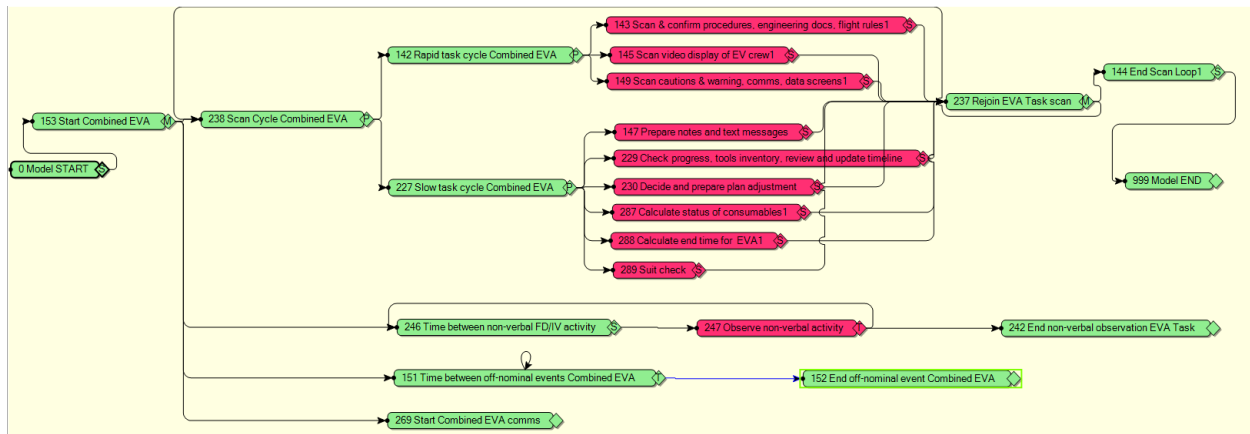
Depending on the nature of the off-nominal condition, one of the three following responses is made:

**Table 20. Off-Nominal Tasks for Hypothetical Combined EVA, EVA Task and EMU Position**

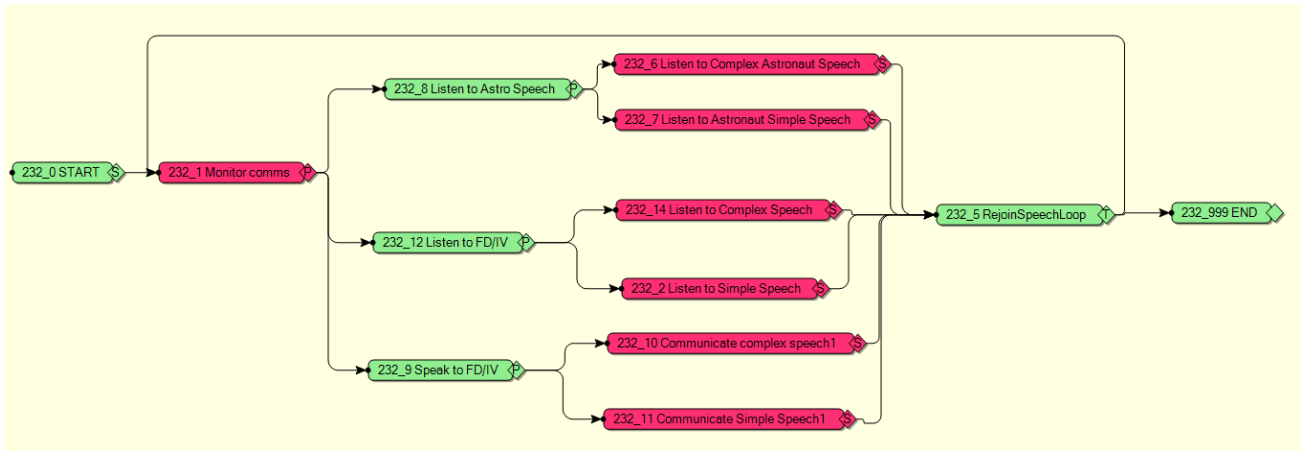
Off-nominal situation		Average frequency	Estimated average duration (seconds)
One of three possible responses to off-nominal:	1. Rapidly apply a prepared decision	Ev 20 min	5
	2. Decide action after referring to crib sheet, flight rules, or other document	Ev 75 min	300
	3. Prepare procedure for complex off-nominal	Ev 2.5 hr	1800

**Combined EVA, EVA TASK, and EMU Model and Results**

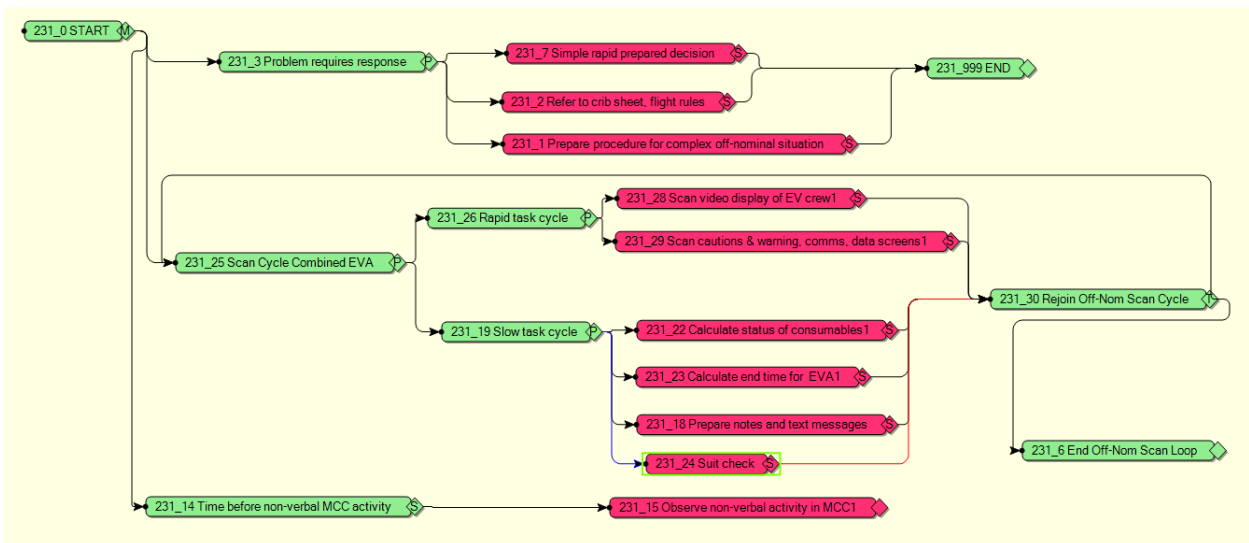
The task model for the hypothetical combined EVA, EVA Task, and EMU position contained three sections, shown below. These are nominal tasks (shown in Figure 49), communication tasks (Figure 50), and tasks that would be performed during an off-nominal event (Figure 51). During an off-nominal event, communication tasks continue, however the nominal tasks shown in Figure 49 are paused and are replaced by the off-nominal tasks shown in Figure 51.



**Figure 49. Nominal Tasks for Hypothetical Combined EVA, EVA TASK, and EMU Position**

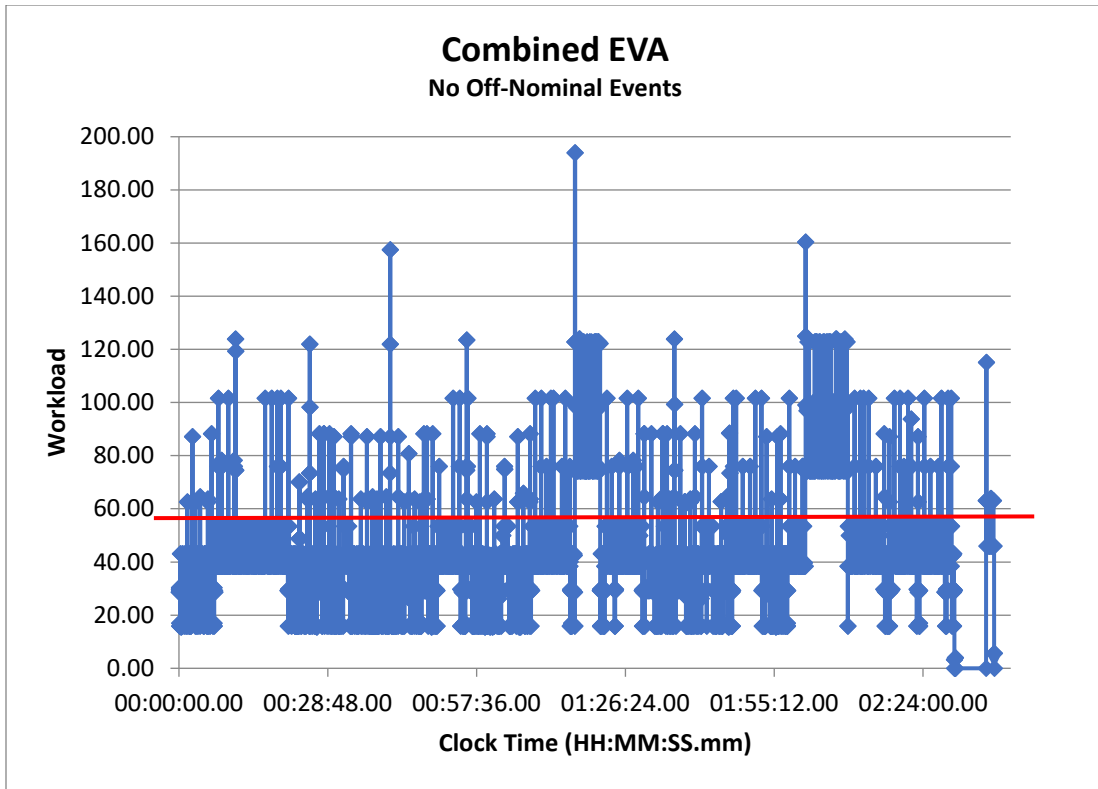


**Figure 50. Communication Tasks for Hypothetical Combined EVA, EVA TASK, and EMU Position**



**Figure 51. Off-nominal Tasks for Hypothetical Combined EVA, EVA TASK, and EMU Position**

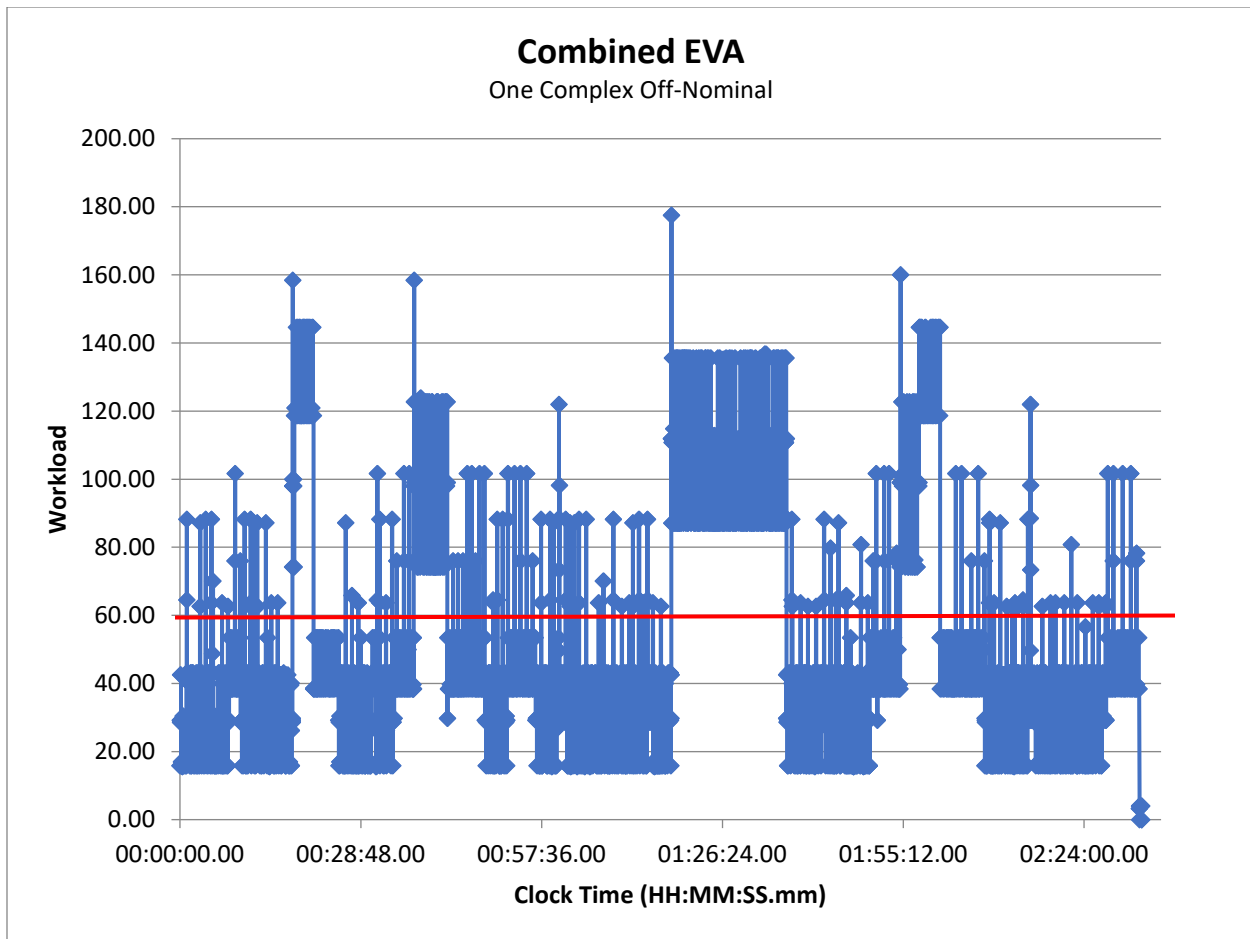
Figure 52 displays predicted Combined EVA workload for a 2.5-hour period of a Mars Planetary Surface EVA scenario generated by the IMPRINT model during no complex off-nominal events occurred. Workload is predicted to be consistently above the 60 threshold, reaching brief peaks as high as 160 and 190. This level of workload would be likely to lead to task shedding. It is also unlikely to be sustainable for an extended period.



**Figure 52. Workload for Combined EVA, EVA Task, and EMU Position with no Off-nominal Events**

Figure 53 displays predicted Combined EVA workload for a 2.5-hour period of a Mars Planetary Surface EVA scenario generated by the IMPRINT model during which a complex off-nominal events occurred at around the 1:18 mark and was not resolved until around 8 minutes later. During the off-nominal situation, workload remained at around 135 as the combined EVA position performed tasks (e.g., preparing a procedure for the complex off-nominal, scanning cautions and warnings) while also listening to complex speech from EV1 or EV2.

Even before the off-nominal occurred, workload was high, with occasional brief peaks to around 160. This level of workload would be likely to lead to task shedding. It is also unlikely to be sustainable for an extended period.



**Figure 53. Workload for Combined EVA, EVA Task, and EMU Position with one Off-nominal Event**

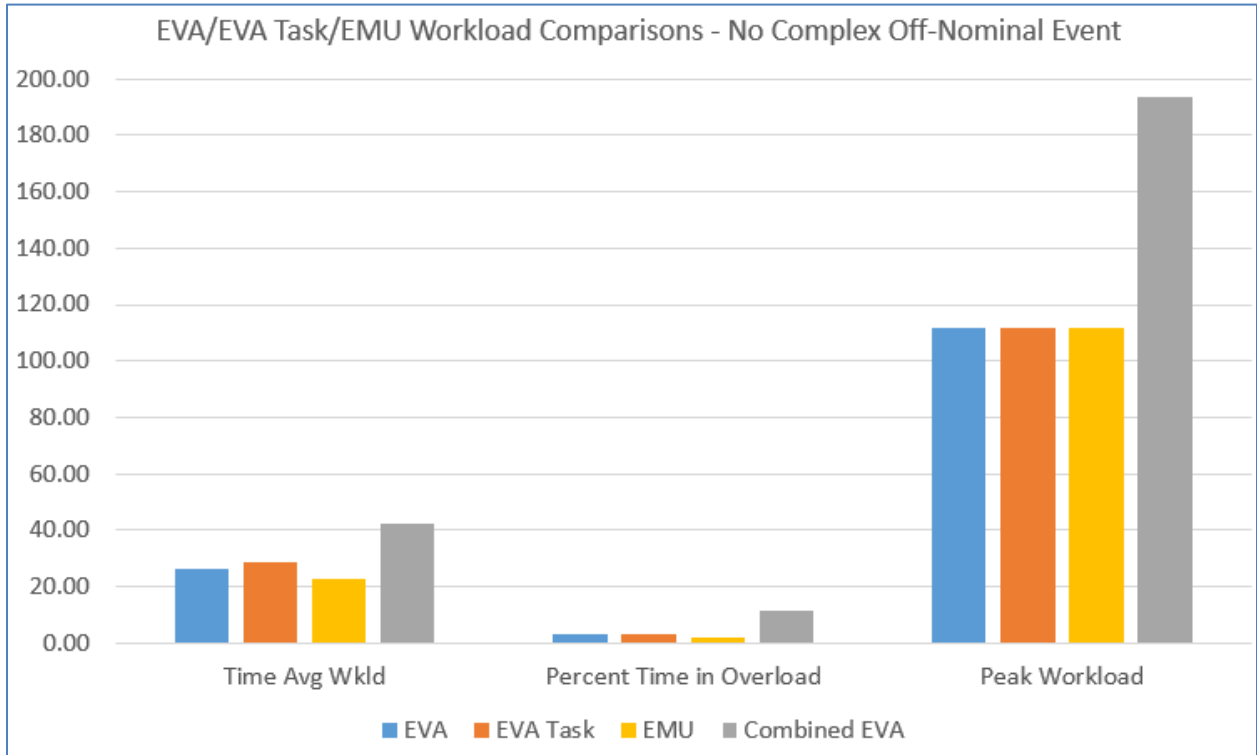
Table 21 presents workload metrics produced by IMPRINT for the two scenarios shown in Figures 52 and 53. Workload for the combined EVA, EVA Task, and EMU position was estimated to be “unacceptably high” for both scenarios. This level of workload would be expected to severely impact task performance.

**Table 21. Combined EVA, EVA Task, and EMU Position Workload Metrics for 2.5-hour Period of a Hypothetical Mars EVA**

	Time-Avg Workload	Percent Time in Overload	Peak Workload
<b>No Complex off-Nominal Events</b>	42.42	11.48	193.89
<b>One Complex Off-Nominal Event</b>	52.17	24.02	177.49

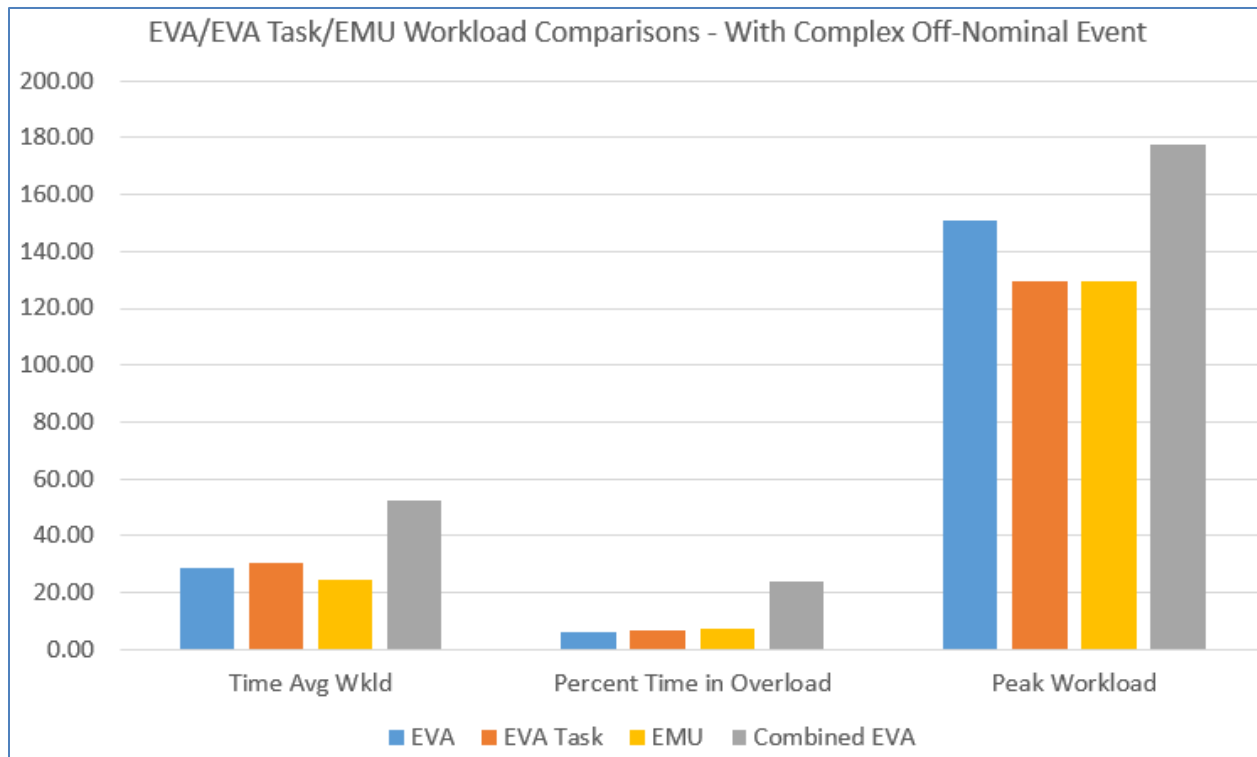
Figures 54 and 55 show workload metrics produced by the IMPRINT models for the current EVA, EVA Task, and EMU positions, alongside the estimated workload for a hypothetical position where one person performs all three of these roles from Mars orbit. The results suggest that a combined EVA/EVA Task/EMU position would experience a significantly higher

workload than currently experienced by each of the individual positions. This is the case, regardless of whether the scenario involves a complex off-nominal event.



**Figure 54. Comparison of Workload for Individual and Combined EVA, EVA Task, and EMU Positions with no Complex Off-nominal Events**





**Figure 55. Comparison of Workload for Individual and Combined EVA, EVA Task, and EMU Positions with one Complex Off-nominal Event**

## **SME Review**

### **Review of Workload Models for Current MCC Positions**

In a second set of interviews, the list of tasks for each position, and the associated timings, workload models, and workload graphs were presented to three SMEs. The SMEs were asked to review the analyses for accuracy and assess whether the output workload graphs appeared to be reasonable. The three SMEs were the flight director, the EMU officer who had participated in the initial data-gathering interviews, and an experienced EVA controller who was also qualified on the EMU position. The Ground IV, EVA, and EVA Task personnel who participated in the initial data gathering interviews were unavailable at the time of the second set of interviews.

The flight director considered that the IMPRINT models for flight director and Ground IV accurately captured the reality of their jobs. He commented that the workload graph for flight director matched his experience. In particular, sharp peaks of workload during an off-nominal condition could lead to brief periods of task saturation. He stated that during these periods of task saturation, it was necessary to slow the pace of events and “unwind” the problem. He noted that if not properly managed, task saturation can lead to bad decisions.

The flight director considered that the Ground IV model and workload graph were realistic. He commented that the workload graph was what he would expect to see for a Ground IV who was a crewmember with EVA experience.

The workload models and graphs for EVA, EVA Task were evaluated by the EVA-qualified SME. Some scan timings were adjusted as a result of the SME review; however, he considered

that the models were reasonable representations of the work of the EVA and EVA flight controllers.

The workload model and graph for the EMU position was evaluated by the EMU officer. He identified that several tasks that were originally shown as paused (or shed) during an off-nominal would continue while a response to the off-nominal was being developed. The resulting change to the model increased the EMU workload during off-nominals. The EMU officer also made several wording corrections to the model, ensuring that tasks were accurately described.

### **Review of Workload Models for Combined Positions**

In conjunction with an examination of task listings and workload graphs, the questions in Table 22 were used to guide the discussion about the feasibility of combined positions for a future Mars Planetary surface EVA. The questions are adapted from the trade space evaluation framework.

### **Combined Flight Director and IV Model**

Resilience. The flight director SME considered that combining the flight director and IV positions would be possible, but it would be necessary to tradeoff efficiency. The SME noted that the CAPCOM and Ground IV are similar positions, and in current MCC ISS operations, the flight director performs CAPCOM role at times when a CAPCOM is not on duty. The SME considered that a combined flight director/IV position would be task saturated during off-nominal situations. However, the SME believed that brief periods of task saturation may be acceptable if the off-nominal situation is not a time critical.

Human Performance. The SME considered that a person could reliably perform the tasks, as long as efficiency could be traded off. Skills would definitely degrade over time. When asked for an example of a skill that degrades, the SME mentioned the ability to manage three or four issues at once as a perishable skill that degrades without regular practice. Skills would also be expected to degrade due to cumulative fatigue if EVAs were being performed without adequate rest days in between. EVAs from the ISS are long days and can be taxing for all involved.

Team coordination. The SME considered that a combined position may be more efficient, and the combination of roles would be unlikely to produce an incoherent set of tasks. This is because it would remove the communication demands between the flight director and IV, eliminating the potential for misunderstandings between the flight director and IV positions, and bringing the flight director closer to the execution of tasks.

The need for coordination may be greatest when it comes to managing the orbital outpost, habitat, or rover.

**Table 22. Guide for Discussion on Feasibility of Combined Positions for a Future Mars Planetary Surface EVA**

<p><b>Resilience</b></p>	<ul style="list-style-type: none"> <li>• Could the crew manage off-nominal events?</li> <li>• Would there be backup if crewmembers became task saturated?</li> </ul>
<p><b>Human Performance</b></p>	<ul style="list-style-type: none"> <li>• How would the configuration affect cognitive workload?</li> <li>• Could a person reliably perform the assigned tasks?</li> <li>• Would the configuration require more from people than they can deliver, in terms of cognitive abilities (e.g., reaction times, memory)</li> <li>• Will crewmembers require specialized competency, training, or experience?</li> <li>• Will these skills degrade over time?</li> </ul>
<p><b>Team Coordination</b></p>	<ul style="list-style-type: none"> <li>• Would the configuration give crewmembers a coherent set of tasks (e.g., no left-over or conflicting tasks)?</li> <li>• Where would coordination with other crewmembers be required?</li> <li>• Would the configuration disrupt the structure of responsibility?</li> <li>• How would the configuration impact coordination?</li> </ul>

**Combined EVA, EVA Task, and EMU Position**

Resilience. The SMEs considered that a combined EVA position would not be able to provide the same level of response currently provided by the three separate positions. When an off-nominal situation arises, it may be necessary to end a Mars Planetary EVA in situations where an ISS EVA would be able to continue.

In current MCC operations, routine tasks can be handed off by the responsible controller if an off-nominal leads to task saturation. The combined configuration does not provide an option to shed tasks or hand them to an assistant.

Well-designed automation may help to reduce the workload of a combined EVA position by handling nominal functions and assisting the human in off-nominal situations with tasks such as troubleshooting and response selection. However, it should not be assumed that increasing levels of automation will reduce workload in all circumstances. As Bainbridge (1983) has noted, “By taking away the easy parts of his task, automation can make the difficult parts of the human operator's task more difficult.”

Human performance. The SMEs considered that these roles could probably be combined when things were going well, particularly if expert system help is available. But when things were not going well, it could be extremely challenging.

The single crewmember performing the combined EVA role would be unlikely to possess all of the specialized competencies that are currently available in the MCC. As a result, there may be more uncertainty about off-nominal situations, and EVAs may be ended early in situations where specialized support, had it been available, would have enabled the EVA to continue. One SME considered that the EV1 and EV2 crewmembers will require specialized training and procedures to enable them to manage the EVA themselves and return to safety when necessary.

Team coordination. It was noted that reducing to two crew onboard an orbiting vehicle reduces communication possibilities, and therefore communication workload.

#### **7.2.2.5 Conclusions**

This element of the assessment modeled the workload of five MCC positions during ISS EVAs, using representative data obtained from ISS EVA 79. The five models were then reduced into two models to estimate the workload involved if a planetary surface EVA on Mars was supported by two crewmembers in Mars orbit performing tasks similar to those performed by the five MCC positions during current ISS EVAs. The IMPRINT modeling system proved to be a useful tool to model workload and promote discussion of this important topic.

#### **ISS Workload Models**

Most interviewees described their tasks in terms of cycles. Some tasks (e.g., scanning camera imagery) cycled rapidly, whereas others (e.g., scanning cautions and warnings) occurred at a lower tempo for most positions.

Every interviewee stated that they monitored multiple flight loops, and a critical skill is the ability to filter pertinent information from non-pertinent information. It is particularly important for controllers to monitor speech that touches on their areas of responsibility and listen to ensure that the information passed up to EV1 and EV2 is correct. Several SMEs mentioned that they used volume control to help distinguish different flight loops. All positions mentioned that they listened to the space ground loop, and in general, controllers avoid talking while crewmembers are speaking. The Quindar beeps that precede crewmember communications also help controllers to focus on crewmember speech.

For the five MCC positions for which models were created, the assessment determined that mental workload during an ISS EVA was frequently high. During nominal operations, brief spikes in workload tended to occur. During complex off-nominal events, sustained periods of high workload were predicted.

Off-nominals occur on virtually all ISS technical EVAs, and it is likely that Mars technical EVAs will experience a comparable frequency of off-nominals. Some off-nominals can be considered to be relatively minor, whereas others have the potential for loss of crew/loss of mission. However, for the purposes of this assessment, off-nominal events were not ranked on criticality. Three broad categories of off-nominals could be identified, depending on whether a solution (1) could be identified rapidly on the basis of skill, training and experience, (2) could be found by reference to documentation (e.g., a crib sheet, procedure or flight rule) possibly with consultation between colleagues, or (3) required a procedure to be prepared, possibly involving problem solving and risk management in the absence of a pre-determined procedure, almost certainly with the assistance of colleagues. The flight director SME stated that it is undesirable to go “off script” during an EVA, that is to be in a situation that has not been anticipated and planned for. The three types of responses to off-nominals can be compared to the Skill-Rule-Knowledge (SRK) distinction of Rasmussen (1983) [ref. 39]. According to Rasmussen, skill-based behavior is characterized as rapid and relatively effortless actions that are under the cognitive control of well-learned, or automatic, routines. Rule-based behavior occurs when the person can respond to a situation by invoking an existing procedure or “if-then” rule. Knowledge-based processing tends to occur in unfamiliar situations, where the person must develop a solution by engaging in resource-intensive conscious problem solving. Of the three

types of cognitive control, knowledge-based problem solving involves the greatest mental workload.

Workload during nominal operations may be manageable, but workload during category 3 off-nominals can spike significantly, and this is likely to produce task shedding. When evaluating whether a task can be performed reliably, peaks in workload are more determinative than average workload. The highest peaks in workload were associated with the concurrent performance of tasks that demanded the same mental resources. For example, listening to complex crewmember speech while simultaneously preparing a procedure for a complex off-nominal situation. One SME specifically mentioned that crewmembers would be likely to be speaking during a complex off-nominal, and this unavoidably contributes to the workload of controllers.

### **Hypothetical Models of Mars Planetary EVA Support**

Combined Flight Director/IV. Workload modeling predicted that a combined flight director/IV position performing tasks similar to those currently assigned to two MCC positions during ISS EVAs would experience an acceptable level of workload in the absence of complex off-nominal events, and a high level of workload during complex off-nominal events.

The flight director SME considered that a combined flight director/IV position may be feasible if EVAs on the surface of Mars had a less ambitious timeline, were more flexible, and occurred at a slower pace than current ISS EVAs. An ability to stop (get to safety) will reduce the need to solve problems in real-time and may therefore avoid some spikes of excessive mental workload. However, in the case of time-critical technical tasks where failure could have loss of crew/loss of mission consequences, a combined flight director/IV crewmember may be unable to avoid spikes of excessive mental workload.

**F-5.** IMPRINT modeling results predict that workload for a crewmember performing a combined set of flight director/IV duties will be acceptable in the absence of complex-off-nominal events but will be high during complex off-nominal events.

Combined EVA Position. Workload modeling predicted that a combined EVA position performing tasks similar to those currently assigned to three MCCs positions during ISS EVAs would experience an unacceptably high level of workload, even in the absence of off-nominal situations. However, SMEs considered that a combined position could be feasible during nominal operations but noted that in the event of an off-nominal, it would not be possible to hand-off tasks to others, or solve problems in real-time. Given that off-nominal situations arise on most EVAs, the combined position would function on the rare EVAs that went entirely according to plan. As a result, some EVAs would be terminated prematurely in situations that could have been solved if more personnel were available to work on problems.

**F-6.** IMPRINT modeling results predict that workload for a crewmember performing a combined set of EVA, EVA Task, and EMU flight controller duties will be unacceptably high level.

The current analysis suggests that two crewmembers orbiting Mars would not be able to adequately manage the workload necessary to provide real-time support to crewmembers

performing a time-critical technical EVA on the surface of Mars for an EVA run at the pace of an ISS EVA. The current analysis was not designed to determine what an adequate number might be, and that question remains to be answered.

**F-7.** Based on analysis of IMPRINT modeling results and MCC EVA flight controllers SME evaluations, two astronauts orbiting Mars would not be able to adequately manage the workload necessary to provide real-time support to astronauts performing a technical EVA on the surface of Mars.

## Limitations

The models of combined positions were best-case situations. The ISS EVA that was used as a source of data (EVA79) was performed efficiently. Tasks associated with managing the ISS, or future Mars spacecraft, habitats or rovers were not included. The depth of real-time expertise available to the five flight controllers from the rest of the MCC and from experts in outside organizations was not modeled, nor was the assistance currently provided by OJT assistants. It was also assumed that only one off-nominal occurred at one. Modeling did not include performance degrading factors (e.g., fatigue) or other factors that may be associated with long duration spaceflight. Currently, ISS EVAs occur over many hours, from preparation through to the final completion, and three MCC shifts cover ISS EVAs. Support crew for a Mars EVA must handle the entire EVA, without the ability to hand responsibility to an oncoming shift.

Based on SME interviews, Mars surface EVAs may be particularly fatiguing for the IV crew who will need to support the EVA without the ability to hand off support to other personnel. Performance of IV crew orbiting Mars would be expected to degrade due to cumulative fatigue if EVAs were being performed without adequate intervening rest days.

Even if tasks can be adequately performed over the course of a Martian Sol, the pace may be difficult to sustain over longer periods due to cumulative fatigue and reduced capabilities as a result of physiological and mental stresses of spaceflight.

ISS EVAs are tightly choreographed and structured, with the aim of maximizing efficiency. This creates an intense need for real-time support from the MCC. If Planetary Surface EVAs were planned to occur at a more relaxed pace, with less ambitious timelines, and an ability to stop (get to safety) occurred with, there may be less need for such intense real-time support.

The current assessment modeled an assembly task. It is possible that such tasks may require EV crewmembers to receive more real-time monitoring and assistance from support personnel than would be the case with less choreographed tasks (e.g., sample collection).

## Future

The current assessment focused on the workload of five out of numerous positions and specialists who support EVAs in real-time. A future assessment could examine the tasks and workload of all personnel who have a real-time involvement in supporting EVAs.

The current study encountered some difficulty in examining the voice inputs and outputs of each MCC position, due to large number of potential voice loops that each position may be using to communicate. A future examination of the MCC workload could benefit if all voice inputs and outputs for each position were available on a single recording.

The current assessment has underscored the need to consider the expected workload of crew when determining the number of crew required for a Mars mission.

### 7.2.3 Robotic Arm Assisted EVA Operator Model

#### ROBOTIC ARM SCENARIO

*The Transit Habitat in Mars orbit with 4 crewmembers on board suffers potentially severe damage on an external system. Time is critical in repairing the damage and the crew has greatly delayed /blackout communication with the ground. The crew quickly determines that the only way to fix the issue is to conduct a two-person EVA, including one person on the end of a robotic arm, with one crewmember controlling the robotic arm while the other crewmember manages and monitors the EVA. Due to advancements in both robotic arm automation technology, including highly reliable systems that avoid obstacles and are very precise with positioning, and improved crew procedures, the crew is able to perform the highly complex mission quickly and averts a disaster.*

The fictional vignette above illustrates the necessity of conducting detailed human performance model studies prior to the development of systems and procedures supporting new, complex missions performed in challenging environments (e.g., Mars endeavors). This modeling effort focused on one mission in particular, similar to that described above, with a sharpened focus on the mental workload experienced by one key operator, the IV crewmember operating the robotic arm inside the vehicle (referred to as the M1 role). While other models associated with this NESC team effort addressed the trades between different number of crew and supporting personnel more directly, this analysis focused on demonstrating how advanced technology capabilities complement the crew, the roles crewmembers have and their impact on one crewmember's mental workload, and other possible factors (e.g., sleep-based fatigue and automation failures).

#### 7.2.3.1 Purpose and Scope

This effort directly addresses NASA's HRP formally acknowledged Risk of Inadequate Human-System Integration Architecture [ref. 40]. This Risk Statement is as follows: "*Given decreasing real-time ground support for execution of complex operations during future explorations missions, there is a possibility of adverse performance outcomes including that crew are unable to adequately respond to unanticipated critical malfunctions or detect safety-critical procedural errors.*"

The Evidence Report specifically identifies robotics as a form of human-system interaction of concern – "Human-robot teaming will be a cornerstone of future operations [p30]. Effective use requires human supportive interfaces for the roles humans will have with respect to robots, particularly to ensure situation awareness of robotic capabilities, actions, plans and health state; and to override the system whenever necessary".

Increasingly capable technology has the potential to offload crewmember workload and reduce fatigue, but simply reallocating tasks to automation/robotics does not necessarily confer only benefits - for example, when crews are less engaged manually, but are required to provide cognitive oversight, skilled performance can degrade over time. Such shifts in the patterns of work can reveal system vulnerabilities [ref. 41]. The Substitution Myth [ref. 40, p. 143] articulates the false assumption that if the function allocation of a task switches from a human to an automated (or robotic) component, that the resulting system remains unchanged. While the

full scope of issues pertaining to function allocation among human and automated/ robotic agents is beyond the domain of this assessment, the purpose of this modeling effort is to demonstrate an approach to assessing trades for different human-automation/robotic configurations with respect to human workload and effects on mission performance time.

### **Scope of Modeled Tasks:**

The example Human-Automation/Robotic Interaction (HARI) mission scenario selected is that of robotic arm assisted EVA. Based on SME interviews, current ISS operations use IV crew as robotic arm operators only for robotic arm assisted EVA and visiting vehicle capture operations. All other operations are teleoperated from MCC Robotics Officer (ROBO). Ground control with respect to robotic arm control has been an evolving story. Originally the robotic system was to be operated by IV crew only [ref. 40]. When robotic tasks became increasingly complicated (requiring additional crew training), and other demands for IV crew time increased (e.g., science), some robotic arm operations moved to ground control. At first it was small slow movements, but now ground control can participate in EVA operations. Additional MCC personnel allowed for more teleoperated robotic operations from the ground.

The scope for this modeling effort derives from the Human System Integration Architecture (HSIA) HRP Risk Evidence Report [ref. 40], which indicates that “increased autonomy, crewmembers must have complementary and enhanced capabilities ... to perform the kind of anomaly response that has previously been done mostly by MCC and complete these in the face of the expected communication delays or unexpected blackouts.”

The modeled scenario is to conduct a robotic arm Assisted EVA from a Mars transit vehicle at a distance from Earth that precluded MCC/ROBO interactions. The motivating scenario for this scope is a repair that has some urgency to conduct, but for which a known procedure, including robotic arm trajectories, is available. The tasking included in model scope includes not only the movement of the robotic arm in a realistic segmented manner, but ancillary tasks including communications involving the M1 controller, monitoring tasks, failure detection, diagnosis and remediation, and supporting an environmental control and life support system (ECLSS) tending task that occurs during the robotic arm assisted EVA.

Variables examined in this effort include: the manner of robotic arm control (Manual versus Automated), the condition of the modeled operator (Rested versus Fatigued), the difficulty of a monitoring and simple response ECLSS task, the degree to which a failure in the automated robotic arm controller is expected and salient, the availability of an additional crewmember to assist the robotic arm operator as an M2, and the workload management strategy employed by the modeled operator.

### **Conducting Robotic Arm Assisted EVAs:**

Current ISS operations conduct the modeled procedures typically with two IV crewmembers, M1 and M2, wherein M1 is at the controls and M2 coordinates with the EVA crew on the robotic arm, tracks the ongoing procedure, controls cameras and confirms motion is as desired. While two crew IV staffing is typical, crew are trained to conduct robotic arm operations with only an M1. Having M1 and M2 increases situation awareness and permits a system of checks and balances, as reported in the HSIA Risk Report [ref. 40, p. 97], and as reported in by IV Crewmember SMEs in this effort.



ISS crewmembers have reported in post-mission briefings that more than one crewmember is required to perform robotics tasks to improve and maintain SA, and that they regularly engage with ground personnel for assistance [ref. 41, pp. 102,103]. In current operations EVA Ground works directly with the EVA crewmember to track task execution, mission time constraints, and crewmember status; and communicates other constraints and changes of plan as coordinated with the flight director. Additionally, in current operations, the MCC team and other support staff may be in communication with M1/M2 with guidance on robotic arm operation or diagnosis. The robotics ground control team consists of three flight controller positions: ROBO, Systems, and Task. ROBO is the ISS MCC robotics position, which oversees all SSRMS and Special Purpose Dexterous Manipulator (SPDM) activities. Task and Systems support ROBO from the MPSR, which are located at NASA Johnson Space Center and the CSA [ref. 42]. The Systems flight controller monitors the telemetry data and is primarily responsible for the state of the system and the Task flight controller monitors the mission and task timelines including procedures to maintain the team's situational awareness [ref. 42]. Additionally, there are ground personnel who manage robotic arm cameras, and the JAXA camera when needed to support IV robotic arm operations. Finally, EVA crewmembers are active participants in robotic arm operations, often providing visualization that is unavailable otherwise.

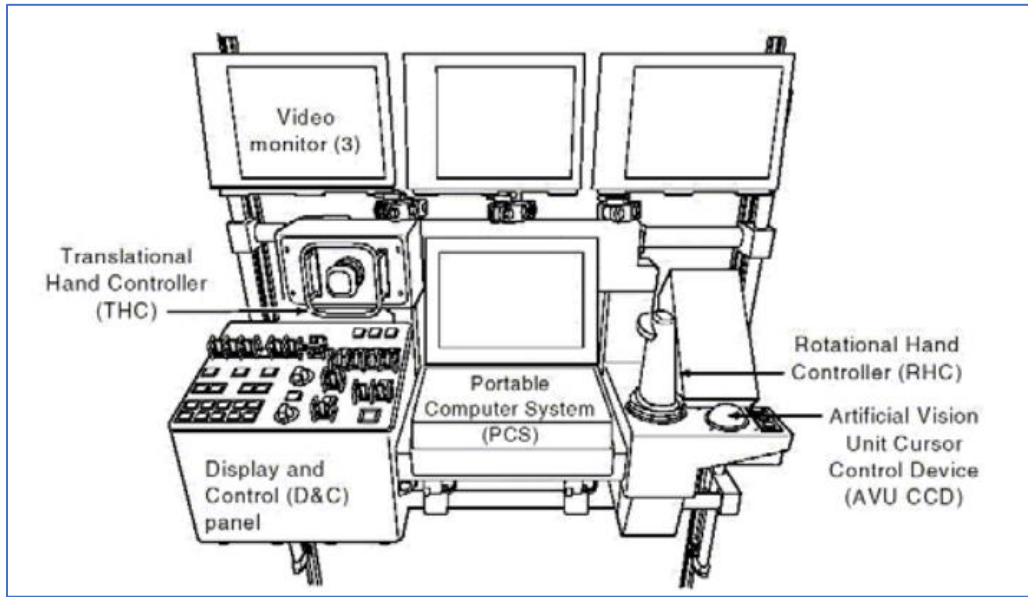
Current ISS operations, relying on this significant ground support, are an evolution from the original intention for robotic arm control. While initially, IV crew were assumed to be able to perform the range of robotic arm control duties, STS-122/ISS 10A (2005) reallocated the majority of pre-move and post operation configurations to ground control [ref. 43, p. 100], with only EVA-assist and visiting vehicle capture as the remaining IV crewmember-controlling robotic arm activities.

In the developed model, the EVA ground responsibilities are assumed to be executed by another IV crewmember proximal to the M1 operator, and Earth-based staff are not available.

### **The Environment and Operator Interfaces:**

The mission scenario is executed in microgravity and the tight confines of a control station. Direct views of the robotic arm through windows are potentially available, but current operations of the robotic arm are often limited by ambient light conditions. Lighting conditions is a significant factor in determining speed when operating in manual mode. Additional perceptual challenges include assessing relative size of features and changing rates of motion [ref. 41, p. 99].

The Robotic Workstation System (RWS) controls and displays are presented in Figure 56. Central to the RWS is the Portable Computer System (PCS), which has a standard keyboard and display. Above the PCS are three additional video monitor systems for camera views and on which information from the PCS can be overlaid. The camera views that are presented on these video monitors are selected and adjusted using the Display and Control panel to the left of the PCS. Manual robotic arm manipulation is executed through use of two hand controllers, the translational controller and the rotational controller. The Artificial Vision Unit (AVU) provides payload positioning information to the operator and can use cameras for photogrammetric image processing. The AVU cursor control device (AVU CCD) permits the operator to control and browse this information. A singularity display (not shown) shows when the robotic arm configuration approaches a configuration in which it has reduced degrees of freedom for movement.



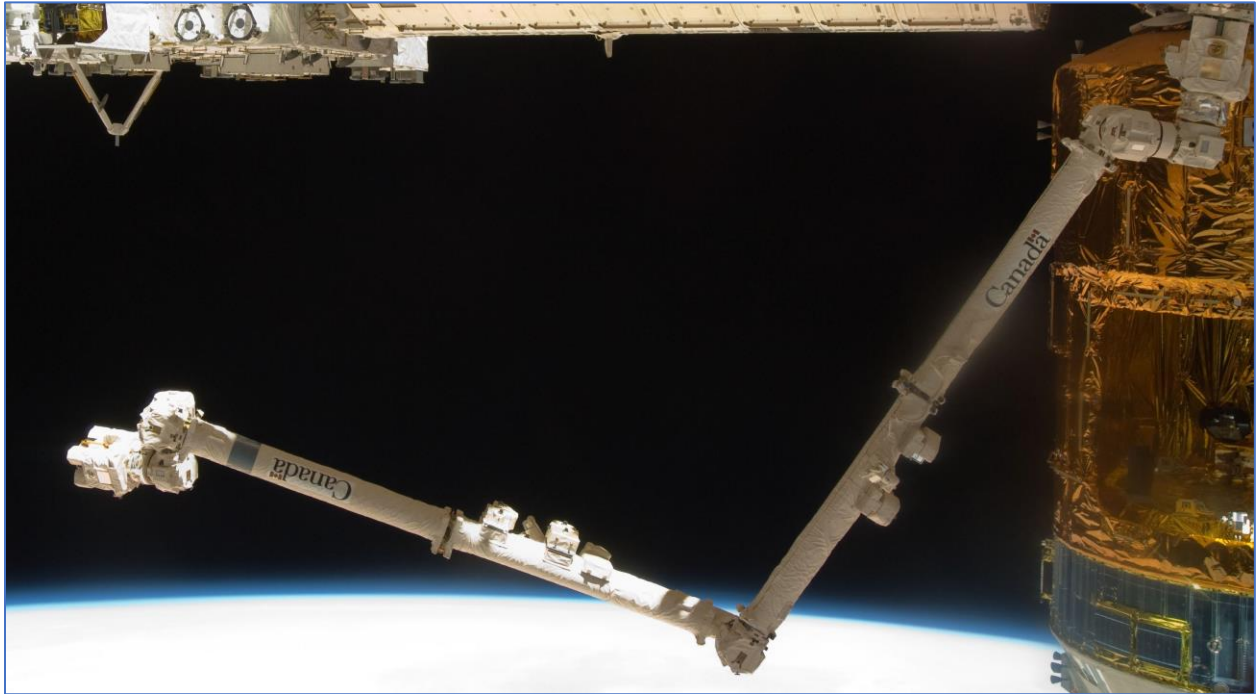
**Figure 56. a. Robotic Workstation and Ancillary Controls and Displays; b. Robotic Workstation On Orbit in ISS**  
 [ref. 2] (Credit b: NASA)

Crew wear communications equipment and have access to portable tablet computers that can display procedures. Paper procedures are also used, with crew-annotations (e.g., for checkpoints, time hacks, and comm content reminders).

**Robotic Arm Modes and Control Task:**

This effort investigates control of the ISS Canadarm robotic arm, or the Space Station Remote Manipulator System (SSRMS) (Figure 57). The SSRMS is a 17-meter-long manipulator consisting of two booms, seven joints, each with a range of  $\pm 270^\circ$ , and two latching end

effectors. Power, data, and video are provided to the payloads via the latching end effectors [ref. 44].



*Figure 57. The SSRMS on Orbit  
(Credit: NASA)*

The varieties of SSRMS operational modes are characterized fully in Reference 38. The modeled robotic arm assisted EVA in this effort includes:

- **Braked:** Mechanical joint brakes are applied, keeping the robotic arm in a fixed configuration.
- **Joint Operator Commanded Auto Sequence (JOCAS):** ISS computers directly enter the desired joint angles for operator confirmation and follows a prescribed trajectory to achieve this configuration. In this mode, M1 references the procedure for the correct final configuration's joint angles, inspects these in the PCS, and executes JOCAS. In ISS operations, JOCAS can be interrupted by the crew, but this model only does this when a failure occurs. Maximum robotic Arm speed is 36cm/sec [ref. 44]. In this model, the robotic arm moves at this fast speed until it approaches the end of a movement.
- **Manual:** Operator controls robotic arm via hand controllers with vehicle frame of reference. SMEs indicated a distinction between Pure GCA (Ground Control Assist – which does not, despite the name, include MCC Ground Control) – movement that is typically relative to the current position (i.e., '10cm body forward'), and GCA-to-Published – relative to a known published location as reference. Manual control in this model uses GCA-to-Published until close to the end of a movement, when Pure GCA occurs. Pure GCA and GCA-to-Published have M1 using the translational and rotational controllers to move the robotic arm. In practice, the speed at which the robotic arm is moved during manual operations varies with operator confidence, mission tempo,

lighting availability and proximity to vehicle. Manual control speeds can be between 25-75% of Vernier speed (8.3cm/sec).

During EVAs, the robotic arm is moved in several movement segments. While in operations, this sequence of movements might include GCA-to-Published and JOCAS, and perhaps other control modes; these models were constructed to execute all 5 movement segments using GCA-to-Published or JOCAS modes. At the end of the final segment, the robotic arm is modeled to move more slowly as it approaches the final worksite. Effectively this is “Pure GCA” where the EVA crewmember directs the M1 to provide movement adjustment to ensure good positioning for the work to be accomplished.

The differences between the Manual (GCA) and the Automated (JOCAS) modes are not simply with respect to control, but also have implications for differences in procedure reference, monitoring, and communications. The particulars of these will be discussed in the context of the developed models.

#### **Ancillary and Contemporaneous Tasks:**

Robotic arm EVAs are in the service of completing tasks outside the vehicle – e.g., repair, and these are managed through procedures for the conduct of this task. The ROBO task has a corresponding procedure that references the task-focused procedure. In current ISS operations, Ground IV manages the procedure and communications with the EVA crewmember to accomplish the work, with input and observations of many other ground staff. In the current model, this role is assumed to be accomplished by another IV crewmember, not included in the model. M1/M2 procedures include tasking that precedes and follows robotic arm movement, and the details for movement and peripheral tasks. These peripheral tasks include communicating cautions, applying and removing brakes, communicating expectations to crew, and data for situation awareness (e.g., estimated duration of movement).

One important set of data that is relevant to the task of robotic arm assisted EVA, but not simply to the movement of the robotic arm itself, is communications with the crewmember on the robotic arm. Communications between the IV M1 robotic arm operator and the robotic arm EVA crewmember were added to reflect these explicit procedural calls, and incidental communications that were observed to arise during actual operations. Per both SME interviews and data from voice loops analyzed, communications differed between GCA and JOCAS operations.

Monitoring is an essential aspect of the robotic arm assisted EVA operation. Beyond the visual monitoring data sources indicated in Figure 56, IV crew conducting robotic arm assisted EVA attend to the procedure, and more tacit aspects of the operations including time management with respect to other constraints (e.g., metabolic constraints, lighting availability, task urgency) and EVA crew manner and affect.

Current ISS robotic arm operations typically have IV crew in the M1 and M2 roles. Some conditions are investigated with only an M1 (representing a reduced crew) and some with M1 and M2. All model variants assessed assume Earth independent operations wherein direct communications to MCC are not available.

#### **7.2.3.2 Methods and Procedures**

This section provides an overview of the IMPRINT/S-Print modeling software environment, source of model data, how individual tasks are characterized and modeled as a task network, the

run types developed to test independent variables of consideration (e.g., whether the robotic arm operation is staffed by only M1 or M1 and M2), planned analyses of these, and the dependent measures upon which these assessments are based.

### **IMPRINT/S-PRINT Approach:**

A unique software modification to IMPRINT was created for NASA called the Space - Performance Research and Integration Tool, or S-PRINT, in 2015 [ref. 45]. This modification added several components to IMPRINT to facilitate mental workload studies applicable to long-duration space missions. Included among the key enhancements was a human-automation interaction (HAI) modeling architecture and associated algorithms that enabled the examination of different levels of automation on mission performance and crew workload, and the impact of different possible automation failures. For this modeling project, the NASA team resurrected the S-PRINT plug-in software and seamlessly added it to a more current version of IMPRINT as a new plug-in. The focus of this IMPRINT operations human performance model was to extend an S-PRINT library model of a crewmember controlling a robotic arm to different possible Mars manning scenarios and different levels of robotic arm automation assistance.

Accompanying S-PRINT development is a library model of a brief robotic arm scenario during a long-duration mission that would impose significant mental workload on one crewmember. Due to assumed crew size constraints, and a potential lack of real-time ground communications, one crewmember is being tasked with operating the robotic arm while also monitoring an ECLSS. Various scenario factors, including controlling the robotic arm manually, faults or out of bounds conditions occurring in ECLSS that require adjustments, and automation failures, can induce high levels of mental workload for the crewmember during a modeled scenario. The library model was developed using data from NASA trainers, crewmembers, and from data collected in studies of college students using a robotics simulation, the Basic Operational Robotic Instructional System (BORIS) and a process control simulation, AutoCAMS to simulate ECLSS.

This library model, however, needed significant changes to represent a more complex scenario of one crewmember controlling a robotic arm with an associated robotic arm assisted EVA. Many changes were made to the library model, and new variations of the model were developed, to represent the scenario of interest more realistically, with a higher degree of fidelity, and to study other scenario variables of interest. These changes are detailed further in a subsequent section of this report.

The U.S. Army Combat Capabilities Development Command (DEVCOM) Analysis Center's (DAC) IMPRINT software, version 4.7.24.0, with the S-PRINT plug-in installed, was used to construct the HARI models. This module added several components to IMPRINT to facilitate mental workload studies applicable to long-duration space missions. The S-PRINT plug-in allows an analyst to characterize automation (HAI Architecture), including levels of automation in different phases of operator assistance, and the consideration of automation failures and attributes associated with those failures. Empirical data of human/automation interactions underpins S-PRINT's approach to modeling the impact that automation characteristics have on human task execution times and operator mental workload.

S-PRINT provides two mechanisms by which to include fatigue effects on task performance - the Sleep, Activity, Fatigue, and Task Effectiveness (SAFTE) capability and the S-PRINT cognitive sleep-debt moderator. Whereas the SAFTE fatigue model impacts all tasks similarly when sleep deprivation or other sleep factors occur, S-PRINT's sleep-debt moderator impacts the

performance of only those tasks that are difficult (high total workload demand) and highly cognitive, by extending the time to perform them and increasing the likelihood of task failure. Both fatigue models are operationalized in IMPRINT by specifying sleep history for the modeled operator. The sleep-debt moderator also has an operator's resistance to sleep debt component that can be considered. SAFTE and the S-PRINT cognitive sleep-debt moderator were implemented for the fatigue studies associated with this modeling effort.

### **Sources of Model Data:**

In addition to using the S-PRINT library model as a baseline for this effort, additional data was collected based on ISS scenarios involving a crewmember conducting an EVA on the end of a robotic arm. The NASA team was able to observe a recent ISS scenario involving an EVA on the end of a robotic arm, US EVA 80, on March 23, 2022. The team was also able to gather procedural information associated with this scenario and listen to voice loops associated with robotic arm control. The team had several virtual meetings with an MCC ROBO SME, and interviewed M1 and M2 operators, in addition to one experienced EVA crewmember who had been on the end of a robotic arm. All SMEs provided the team with system operation expertise, procedures, and answers to many technical questions to assist in increasing the fidelity of the human performance model.

In summary, the team's resources for model development included the following:

- Resources
  - EVA flight following observations and Collaborative Operations Data Activation (CODA) review
  - Mission voice loops
  - Operational procedures
  - Training information
  - Literature reviews of robotic arm operations
  - Crew Comment Database<sup>11</sup> (CCDB)
- Interviews/Discussions
  - A certified MCC ROBO flight controller
  - Several M1 and M2 IV ROBO operators
  - A liaison and expert on CANADARM
  - An EVA crewmember who was on the end of a robotic arm
  - NASA personnel who conducted previous robotic arm controller task analyses

The model was initially developed by conducting flight following of relevant scenarios and further analyzing voice and video of these, and reviewing related procedures and documentation describing tasks, robotic arm, and the RWS. After this initial development, the resulting models and preliminary results were reviewed by MCC ROBO, M1 and M2 SMEs. Significant input from these reviews drove model updates to increase their fidelity further. Some of these

---

<sup>11</sup> The Crew Comments Database (CCDB) is a repository maintained by the Johnson Space Center Flight Crew Integration Operational Habitability team for crew spaceflight operations debrief feedback spanning the ISS 2A missions to the present containing over 110,000 unique comments. Although summaries of ISS crew comments are presented as evidence, the CCDB is protected and not publicly available, due to the sensitive nature of the attributable crew data it contains. CCDB data is classified as a response "Not Highly Representative of the Crew Office (CB)." It is considered a formal opinion and should not be utilized to determine crew consensus but can aid in the identification of issues or trends via analysis of related comments.

additional updates included revised, more complex, communication networks that varied communication frequency depending on phases of operation, a more complex and representative monitoring network, and some revised task times and task mental workload scores. SMEs who have performed as M1/M2 and EVA on the robotic arm, and a researcher who has previously analyzed tasks associated with robotic arm assisted EVAs reviewed workload and execution time results of baseline GCA and JOCAS models. Additionally, a Canadarm SME provided useful commentary regarding possible future technology extensions for robotic arm capabilities and interfaces. Finally, a crewmember who has been trained for M1/M2 was interviewed to assess five crew conditions with respect to the framework provided by Militello et al., 2019 [ref. 4], and as modified in the trade space evaluation methodology provided above (Section 6.3.5).

### **Task Duration Characterization:**

Each task is characterized by the time it takes the M1 to complete it. Task execution times can be modeled as constants and with a variety of distributions. This modeling effort used triangular distributions when obtaining time estimates from sparse data or from SMEs, as this mirrors the way people generally think about time (the shortest, longest, and most frequent duration experienced). Normal distributions were used when ample data was available to reliably calculate parameters. Gamma distributions were employed when a task might take longer to perform on some occasions, with a normal distribution representing lower performance times. An example in which a gamma distribution was used was for long communication times.

For the main model, communication task times were obtained by obtaining timestamp data from REVA comms during EVA80, parsing these by robotic arm control type and as before/during/after movement utterances. Speeds associated with robotic arm movements were provided by MCC ROBO SME and typical manual speeds vetted with M1/M2 crew.

Tasks associated with monitoring various information sources were derived from analysis of the EVA80 Jumper Install procedure, wherein the M1's point of gaze was inferred to be on the robotic workstation controls/displays during data entry and distance call outs, on the procedure for each new step in it, and most often monitoring the camera/out the window view.

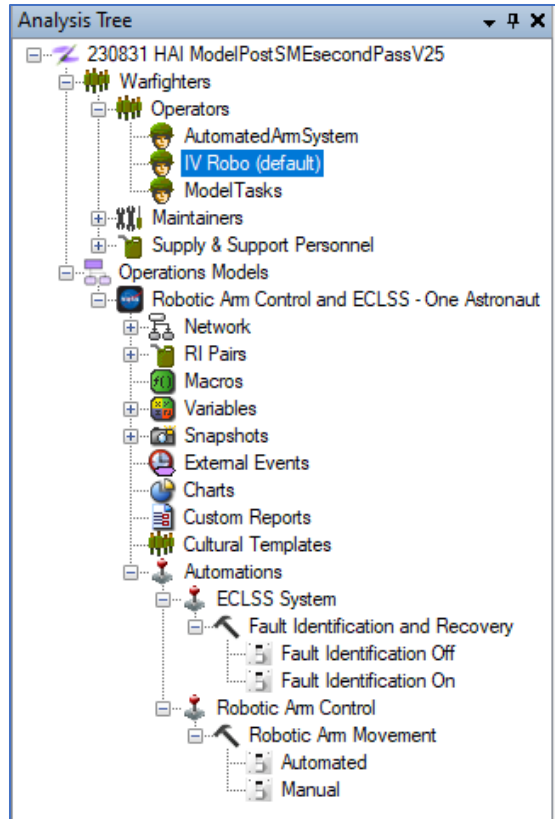
### **Modeled Operator Workload Characterization:**

Workload scores for each task were characterized in different resources for their auditory, cognitive, fine motor, speech, and visual demands. IMPRINT provides descriptive guidance for workload level characterization for each type of demand based on benchmarks within each resource channel which supports appropriate and consistent characterization across constituent tasks. While workload scores were not based on empirical data for this initial modeling effort, IMPRINT modeling experts and operational experts reviewed correspondence of these data to assess consistency and accuracy with respect to ISS EVA robotic arm operations.

### **IMPRINT/S-Print Human Performance Model Features:**

All scenario models were built using IMPRINT, the S-PRINT software plug-in with the HAI architecture, and IMPRINT's goal-oriented modeling capability. By using the S-PRINT plug-in, automated systems associated with the model were able to be defined, including those systems associated with the robotic arm control. Figure 58 shows the automation levels defined for ECLSS and robotic arm control expanded at the bottom of the IMPRINT analysis tree. Also highlighted in the tree is the one real operator modeled in this scenario, the IV crewmember serving as the M1 robotic arm operator.

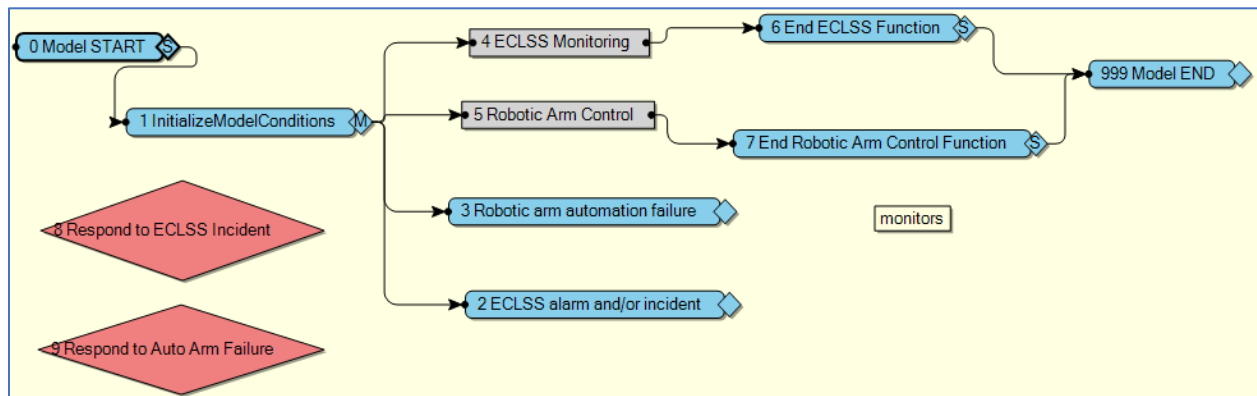




**Figure 58. Automations defined in the IMPRINT Analysis Tree**

**Task Network Model Structure:**

For the IMPRINT task network model, at the highest level, the modeled scenario contains functions (the gray boxes in Figure 59) that have subnetworks with more detailed tasks for the crewmember monitoring ECLSS and controlling the robotic arm, and goals (the large red diamonds) which are subnetworks for addressing incidents (e.g., a robotic arm automated control failure).



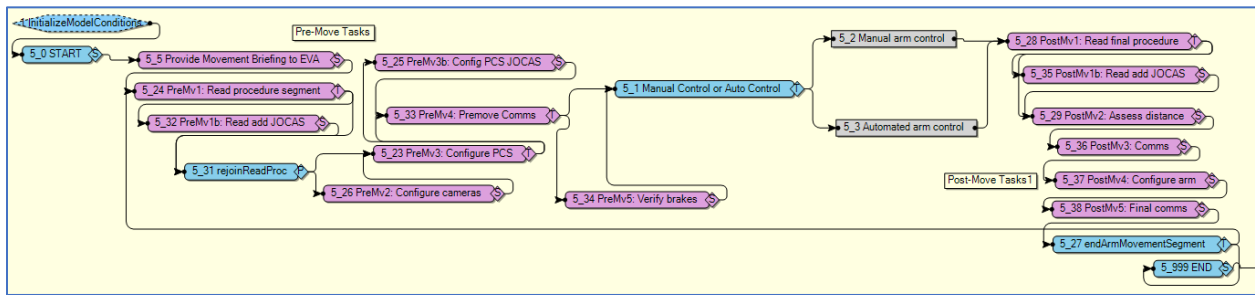
**Figure 59. Highest Level IMPRINT Task Network Model**

Tasks in the model are color-coded according to the assigned operator. Blue tasks represent model tasks (i.e., tasks not representing a person taking an action). Model tasks are used to make the model run correctly. In addition to starts, ends, and rejoins, model tasks can also be used to



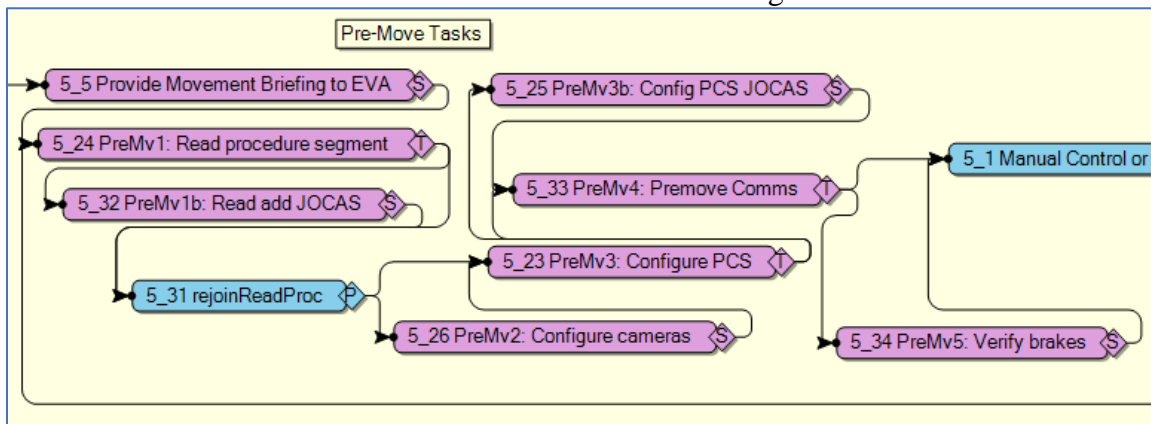
initialize model conditions, trigger events to occur, or to represent time delays. Yellow tasks in the model are actions being performed by an automated system (e.g., automation controlling robotic arm movement in JOCAS mode). Finally, most tasks in the model are plum colored and assigned to the M1 IV robotic arm operator. These tasks represent actions being performed by the operator of interest and contain timing information, decision logic, and mental workload values that impact model execution and data collection.

Figure 60 shows the more detailed task network model for robotic arm control (Function 5 in Figure 87). In a significant departure from the S-PRINT library model, and a much more realistic representation of a robotic arm assisted EVA, robotic arm movement is in segments, and each segment has pre-move and post-move tasks associated with it. The entire mission consists of moving a robotic arm with an EVA in a staple pattern, 8 feet vertical, 30 feet horizontal, and 8 feet vertical. For simplicity, it has been broken into 5 robotic arm movement segments, 1 for each vertical movement, and 3 equal length segments for the horizontal movement.

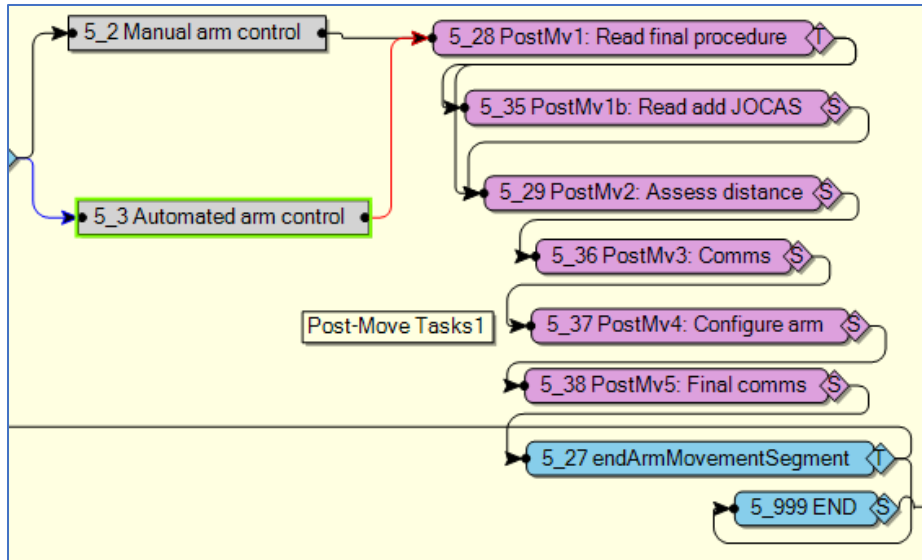


**Figure 60. Robotic Arm Control Segment Task Network**

Figure 61 shows the pre-movement tasks associated with each robotic arm movement segment. Some tasks (e.g., “Config PCS JOCAS”) are only applicable to the JOCAS mode of operations and model logic ensures they are only selected during that mode. Figure 62 shows the post-movement tasks associated with each robotic arm movement segment.



**Figure 61. Pre-movement Tasks**



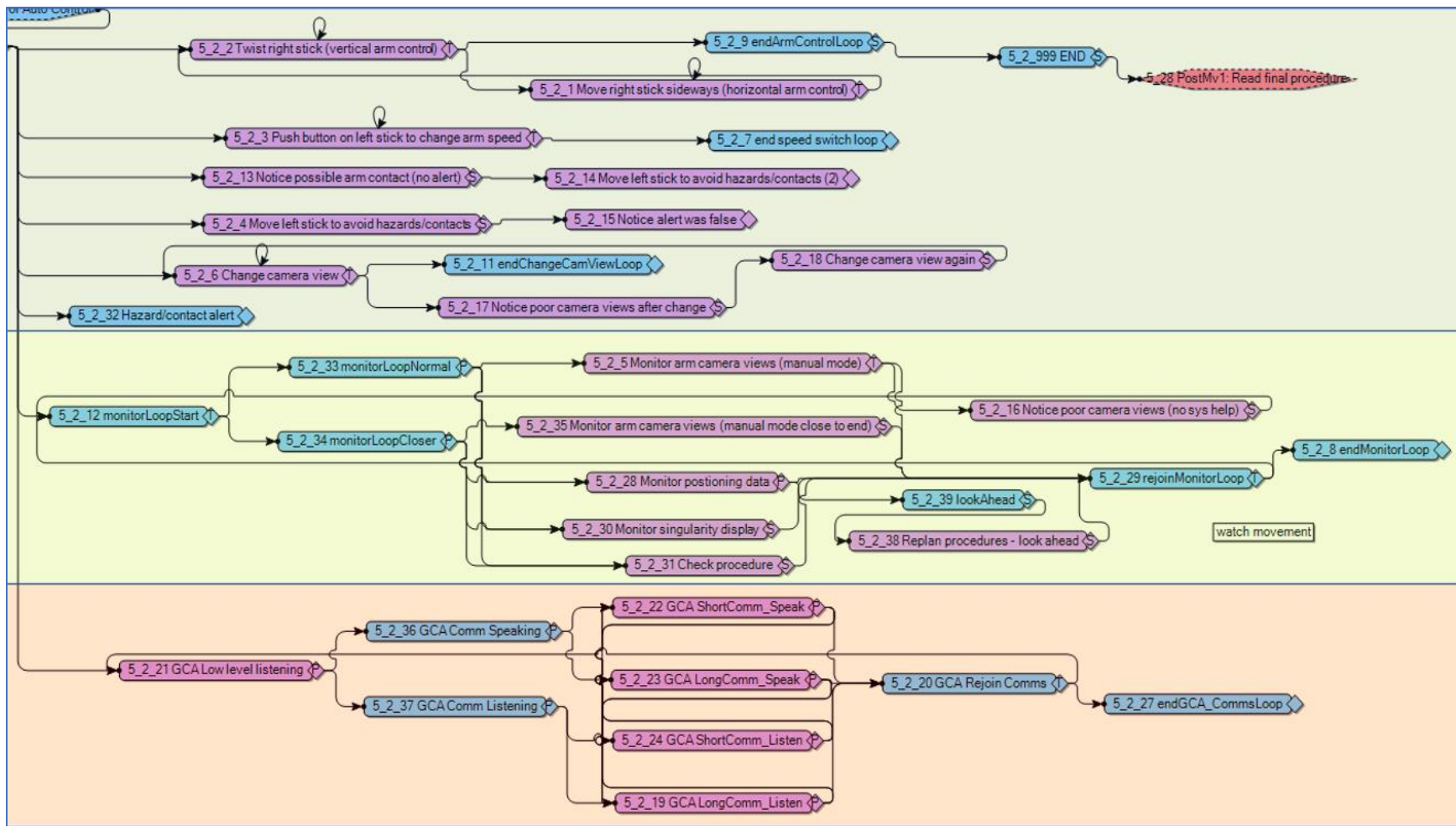
**Figure 62. Post-movement Tasks**

Figure 62 also shows the branch where the model chooses the manual robotic arm control or the automated robotic arm control function. The manual robotic arm control function will be discussed in more detail, and differences in the automated robotic arm control function will be shown and discussed.

Figure 63 shows the detailed task network diagram for one M1 controlling the robotic arm manually. The diagram has been broken into three horizontal sections representing different main subnetworks with different background colors. The top subnetwork, with a green background, represents task required to move the robotic arm. The main tasks being constantly engaged are moving the control sticks to move the robotic arm vertically or horizontally, at the top of that subnetwork. Other tasks that are intermittently performed include moving the controls more abruptly (higher workload) to avoid an obstacle, changing robotic arm speed, and changing a camera view.

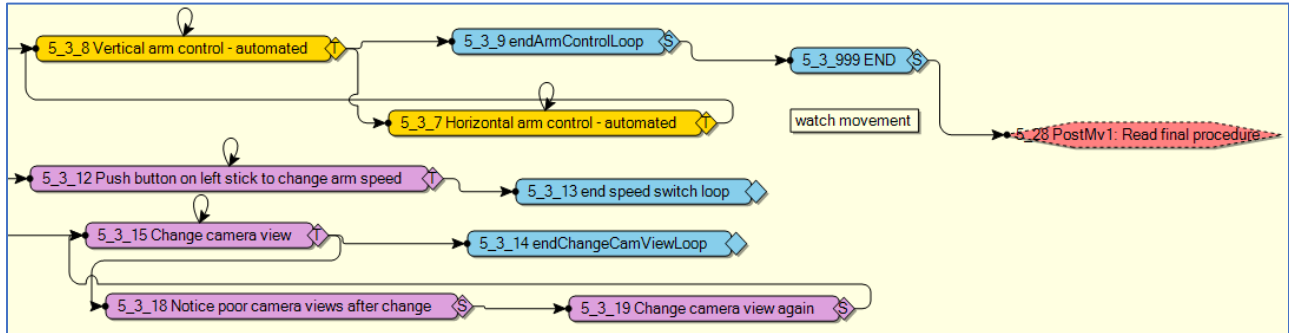
The middle network on a yellow background represents monitoring tasks being performed by the M1 IV crewmember. Monitoring data was defined by analyzing procedures and determining the appropriate sources of information for each step. Per data collected, they spend the most time monitoring camera views, but considered this task to be more intense (higher workload) near the end of the mission when the robotic arm was close to its final location. A task was added for this. Other monitor tasks include monitoring positioning data, monitoring a singularity display, and checking procedures. A task to occasionally look ahead or replan movements was also added to this subnetwork based on SME feedback.

Finally, the lower network on an orange background represents communication tasks. At the very least, the M1 IV crewmember is always listening for communications. There is a very low-level workload task for this that is engaged whenever a real communication is not taking place. The communication network, like the monitoring network, contains logic to allow for differences in communication frequencies and types change between different modes of operation and in different phases of robotic arm movement.



**Figure 63. Manual Robotic Arm Movement Task Network**

Figure 64 shows the robotic arm movement portion of the entire network diagram for automated robotic arm control. The main difference between this diagram and that for manual control is that automation is moving the robotic arm, shown by yellow tasks. The rest of the robotic arm movement network diagram for automated robotic arm control, including the monitoring tasks subnetwork and the communication tasks subnetwork, are similar to that for manual robotic arm control. However, task frequencies and times differ based on observational data and SME input.



**Figure 64. Auto Robotic Arm Movement Task Network**

Figure 65 shows the task network diagram for responding to an automated robotic arm control failure. The tasks on the left side of the network diagram represent necessary troubleshooting tasks to understand the problem and ensure the EVA is safe. For these models, it is assumed that the control failure does not cause damage to the arm, there is a delay involved for diagnosis, and eventually the robotic arm is switched to manual control and the movement mission is completed manually. The self-contained goal network (it suspends the main mission when it is triggered) also included communication tasks performed during troubleshooting, the ECLSS monitoring function, and the entire segment diagram for controlling the robotic arm including pre-move and post-move tasks and the function for manual robotic arm control.

Figure 66 shows the robotic arm control automation settings that are part of the HAI architecture installed with the S-PRINT plug-in. The first grouping of attributes for each automated mode (Automated and Manual) shows the level of automation assistance provide by each mode across four phases of possible support (Alert, Diagnose, Decide, Control). The only difference between the two levels of automation modeled are the reside in control (high control versus manual). To the right of the table interface, a user Modelers can declare that different possible automation failures are “expected” (possible low trust in automation/more monitoring) or “unexpected” (possible high trust in automation/less monitoring) (Figure 66, right-most three columns). If an automation failure is unexpected, it may take longer to be detected and recovery time will likely be extended.

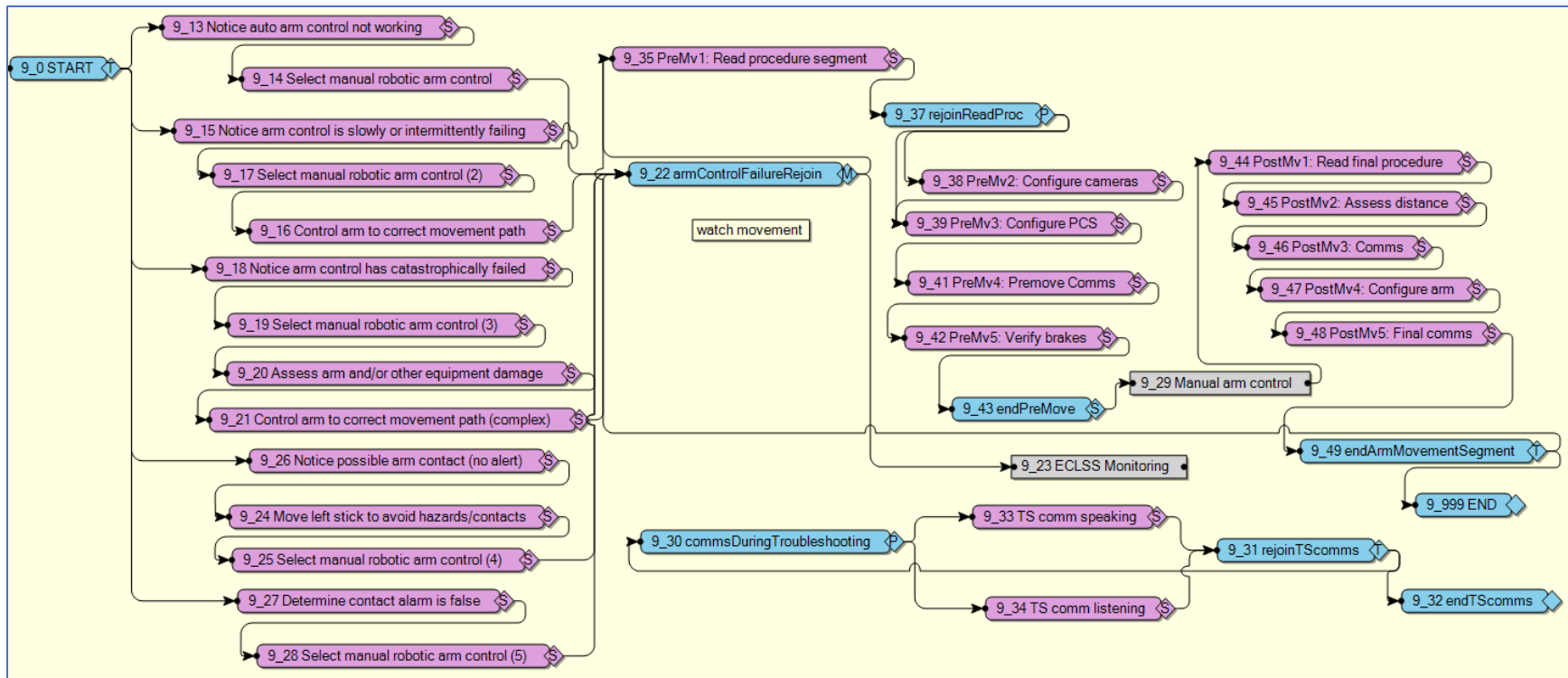


Figure 65. Respond to Auto Failure Task Network

Automation Name: Robotic Arm Control

Function Name: Robotic Arm Movement

Mode	Alert	Diagnose	Decide	Control	Selected	Reliability									
						Alert			Diagnosis		Decision		Control		
						Gone	False Alarm	Miss	Gone	Wrong	Gone	Wrong	Gone	Catastrophic	Slow Failure
Automated	High Automation	Low Automation	Low Automation	High Automation	<input checked="" type="checkbox"/>	Unexpected	Unexpected	Unexpected	Unexpected	Unexpected	Unexpected	Unexpected	Unexpected	Unexpected	Unexpected
Manual	High Automation	Low Automation	Low Automation	Manual	<input type="checkbox"/>	Unexpected	Unexpected	Unexpected	Unexpected	Unexpected	Unexpected	Unexpected	Unexpected	Unexpected	Unexpected

Figure 66. Robotic Arm Control Automation Settings

The HAI architecture also allows automation failures to be scripted during model runs to see what their impact is on overall mission performance. In the example shown in Figure 67, a slow control failure is scripted to occur at 10 minutes and 30 seconds into a model run. Another important attribute of automation that impacts response tasks is the salience of the failure. If a failure is highly salient, as the example for robotic arm control shown in the figure, it is more likely to be noticed and dealt with in a timely manner.

Automation Failures		Activate Failure	Failure Start Time	Failure Type	Failure Salience
Robotic Arm Control / Robotic Arm Movement / Automated		True	00:10:30.00	Control - Slow Failure	High
ECLSS System / Fault Identification and Recovery / Fault Identification On		False	00:01:00.00	Alert - False Alarm	None

*Figure 67. Robotic Arm Control Automation Settings*

### Model Variables, Versions, and Analysis Plan:

Several versions of the IMPRINT robotic arm assisted EVA human performance model were developed to analyze different variables that could be associated with missions to Mars. The following summarizes the variables that were changed for different model runs:

- The baseline S-PRINT model was expanded to include higher fidelity models of the robotic arm being controlled **manually (GCA)** versus **automated arm control (JOCAS)** by one operator, an **M1**. Modeled scenarios without failures are GCA or JOCAS controlled – there are no mixed operations. When a robotic arm control failure occurred in JOCAS mode, the robotic arm control switched back to manual.
- Most model runs were executed assuming a rested crew (8 hours of sleep per night for the previous 4 nights, **no fatigue effect**). Some model runs were executed assuming a **sleep-based fatigue effect** due to sleep deprivation of 4 hours of sleep per night for the previous 4 nights.
- In JOCAS mode, **automated robotic arm control failures** were scripted to occur during some model runs. For one of these runs, the failure was detected, corrective action was taken, and the robotic arm was switched to manual control, but no HAI time penalty associated with the automation failure was imposed on applicable tasks.
- For other model runs with scripted automated robotic arm control failures, variables associated with the failure were modified between runs and the **HAI time penalty** was applied to applicable tasks. These variables included the **expectancy of the failure (unexpected versus expected)**, and the **salience of the failure (no salience versus high salience)**.
- Due to an assumed limited Mars mission crew size, it is also assumed that the M1 IV crewmember is being tasked to monitor an ECLSS during the mission. In most cases, it is assumed that **ECLSS has a robust alerting system**, is easy to monitor and operate, and has lower workload (“Easy ECLSS”). However, for two model runs, it is assumed that **ECLSS does not have a robust alerting system** and is more difficult to monitor and operate, and has higher workload (“Hard ECLSS”).

- Part of the robotic arm operator analysis is studying the impact of automation on operator workload and mission performance. However, another variable was added to see how having **another crewmember available to assist with robotic arm operations, an M2**, would impact the mission. It was assumed that the M2 took over ECLSS monitoring and operations, some communications (with some communications between the M1 and M2 remains necessary), reading procedures, and switching camera views.
- The final variable added was the addition of **IMPRINT workload management strategies** to a high workload baseline model run. Workload management strategies assume an operator will delay task performance whenever an overload condition (overall workload above 60) will occur. Most runs assumed no workload management strategies (all tasks were performed as scheduled).

Table 23 summarizes every model run associated with the robotic arm assisted EVA human performance model analysis. Bold items in the table denote differences from previous runs and help to highlight them. The model run numbers used in this table will subsequently be used to delineate model run comparisons that were conducted.

*Table 23. HARI Model Runs Summarized by Variables Changed*

No.	Arm Control Mode	Fatigue Applied	Scripted Auto Failure	Failure Expected	Failure Saliency	ECLSS Difficulty	Add M2	Wkld Mgmt
01	GCA	No	No	n/a	n/a	Easy	No	No
02	<b>JOCAS</b>	No	No	n/a	n/a	Easy	No	No
03	GCA	<b>Yes</b>	No	n/a	n/a	Easy	No	No
04	JOCAS	<b>Yes</b>	No	n/a	n/a	Easy	No	No
05	JOCAS	No	<b>Yes</b>	n/a	n/a	Easy	No	No
06	JOCAS	No	<b>Yes</b>	<b>Yes</b>	<b>None</b>	Easy	No	No
07	JOCAS	No	<b>Yes</b>	<b>Yes</b>	<b>High</b>	Easy	No	No
08	JOCAS	No	<b>Yes</b>	<b>No</b>	<b>None</b>	Easy	No	No
09	JOCAS	No	<b>Yes</b>	<b>No</b>	<b>High</b>	Easy	No	No
10	JOCAS	<b>Yes</b>	<b>Yes</b>	<b>No</b>	<b>None</b>	Easy	No	No
11	GCA	No	No	n/a	n/a	<b>Hard</b>	No	No
12	JOCAS	No	No	n/a	n/a	<b>Hard</b>	No	No
13	GCA	No	No	n/a	n/a	Easy	<b>Yes</b>	No
14	JOCAS	No	No	n/a	n/a	Easy	<b>Yes</b>	No
15	GCA	No	No	n/a	n/a	Easy	No	<b>Yes</b>

After running all models above to collect data (data for 30 model runs collected for mission times and other timing analysis data, data for workload collected and analyzed for one representative run for each model), the following comparative analyses were conducted:



**Table 24. HARI Model Comparative Analyses Summarized**

No.	Analysis Name	Model Runs Compared	Analysis Description
1	Baseline GCA vs JOCAS	01 and 02	Baseline analysis of GCA (manual robotic arm) operations to JOCAS (automated robotic arm) operations.
2	Baseline Fatigue	03, 04 with 01, 02, respectively	The impact of sleep debt-based fatigue (assuming 4 hours of sleep per night for 4 previous nights) to GCA and JOCAS operations.
3	Scripted Automation Failure	05 to 02	Compared the impact of a scripted automated robotic arm control failure with no HAI time penalty effects with the baseline JOCAS run.
4	Auto Failure Attribute Effects	05 through 09	Compared the impact of different levels of automation failure expectancy, and failure salience, associated with automation robotic arm control failures scripted similar to run 05 but with associated HAI time penalties considered.
5	Auto Failure with Fatigue	10 to 08	Compared the worst case JOCAS failure (unexpected and with no salience, run 08) with the same case JOCAS failure with sleep debt-based fatigue applied.
6	ECLSS Hard	11, 12 with 01, 02, respectively	Most of the model runs were conducted assuming an ECLSS system with a very clear failure alerting system that made the system easier to monitor and manage. Runs 11 and 12 assume an ECLSS system without a failure alerting system that is slightly more difficult to monitor and manage.
7	Added M2 Crewmember	13, 14 with 01, 02, respectively	Assume that another crewmember, an M2, is available to take on some of the duties that the lone robotic arm operator is being tasked to perform. This includes the ECLSS monitoring tasks, reading procedures, and many of the communication tasks (although M1 will be communicating with the new M2 position), switching camera views, and some monitoring tasking.
8	Workload Strategies	15 with 01	Take one of the highest workload models, the baseline GCA model and apply IMPRINT workload management strategies that do not allow the robotic arm operator's mental workload to get above the threshold of 60.

**Dependent Measures:**

The main measures of mission (a mission in IMPRINT equates to a scenario modeled) success in IMPRINT applicable to this modeling effort were operator mental workload and mission execution time. Workload reports provide the modeled operator's workload level over simulation time and indicate the tasks being executed at different times (so an analyst can see exactly which tasks were being performed simultaneously during periods of high workload).

Mission (scenario) execution time is a single value for an executed model run, derived from the instances of the task durations provided by the simulation and the order in which tasks occur as executed in the simulation. Scenario models can be executed multiple times, with each run having a unique initial random number seed, to obtain variations in mission execution time and subsequently compare multiple model runs with one set of conditions versus another set of



model runs with varying conditions (e.g., no fatigue versus fatigue). Descriptive statistics for mission execution time are then calculated (e.g., mean time, minimum time, maximum time). For the robotic-arm-assisted EVA model in particular, it was useful to distinguish between the mission execution time and the time required only to move the robotic arm. When these additional metrics are deemed useful, the model must include delimiting variables to characterize the appropriate conditions, and a variable to store the metric.

### **7.2.3.3 Assumptions and Model Limitations**

The human performance models developed for this effort are largely based on existing analogous systems and missions extended to a Mars mission environment with unique challenges anticipated.

1. This model assumed that the crew was in a situation where they had to perform the robotic arm tasks autonomously without MCC support due to communication delay/blackout and assumed that the crew was fully autonomous in the execution of the necessary repair. The model assumed that for most scenarios only one crewmember conducted the robotic arm control. While missions to Mars may require such crew autonomy and staffing, the current practice of ISS crew commonly interacting with ground support during robotics operations [ref. 40] and SME comments about the “invaluable.” benefits of having an M2 as “another set of eyes on” and “someone to bounce ideas off of” underscores the importance of fully characterizing tasking demands, including the functionality of providing checks and balances. In ISS operations, the roles of M1 and M2 differ by crew and are often fluid in response to situational demands of the robotic arm assisted EVA task at hand and other concurrent tasking as required. This model did not fully vary all possible task allocations and resulting team dynamics.
2. The scenario modeled here assumed that while the need to conduct this EVA was not anticipated, the procedure for how to conduct this robotic arm assisted EVA was already developed and assessed to whatever level it could be assessed, given time pressure, prior to execution. The scope of the current robotic arm assisted EVA model begins with the pre-move procedure and ends with the post-move procedure when the crewmember arrives at the worksite. It is important to realize that what might be the most cognitively demanding tasks associated with robotic arm operations are not included – trajectory generation, planning communications with EVA crewmembers that necessitate translating among frames of reference, contingency management planning throughout operations. Further, SME M1/M2, when asked how they would do this, have said that they defer to the “ROBO Geeks” for that skill set. Although analogous procedures used to develop the robotic arm models were based on ISS SSRMS, and crew SMEs were also ISS SSRMS robotic operators, the scenario modeled was a simple staple movement and could be applicable to a simpler robotic arm that might exist on a future Mars transit vehicle.
3. It was also assumed that some tasks (e.g., tending to the ECLSS system) were critical and had to be performed simultaneously with the robotic arm task. To focus the study on the robotic arm controller, and robotic arm control, no ECLSS automation failures were scripted during this scenario and the ECLSS system control was a constant unless a larger crew size dictated that it could be moved from the Robotic Arm controller. It was assumed that increasing the Mars crew size would allow the M1 crewmember controlling the robotic arm to shed some tasks from the baseline smallest crew model (e.g., ECLSS tasks). The default ECLSS mode and associated tasking required fairly minimal demand from the M1. However,

for some runs, a more difficult ECLSS system and associated demands were introduced. The more difficult ECLSS system did not have an advanced alerting system and thus required more frequent monitoring, with longer fixation times and higher cognitive and visual workload components. It also required the astronaut to occasionally adjust their history graph view to interpret changes in ECLSS conditions.

4. Chang & Marquez (2018) highlight, and conversations with SMEs underscore, the fact that there are aspects of Robotic Arm operations by M1/M2 performance that are difficult to ascertain simply from analyzing the relevant procedures [ref. 42]. Some of these “implicit tasks and challenges” are more evident when observing operations, e.g., during flight following and review of audio loops, but even this more ethnographic form of data collection did not reveal some aspects of tasking that affect workload and performance time in real operations. Some of these types of tasks and challenges that were addressed in this model, and how they were addressed include:

- Listening for incoming communications and off-nominal conditions. (This model includes a task that adds workload associated with listening for incoming comms).
- Interpreting noisy communications and doubling back to confirm these. (This model used empirical data to describe communication task duration, and included back and forth communications, without delays, with model logic).
- Concern and caution when operating in more risk-adverse contexts (e.g., being close to structure). This model implemented slowing when close to the final location – presumably a point where the robotic arm is close to structure, and this final movement was higher workload for the GCA mode than for the JOCAS mode.

Additional implicit tasks and challenges that were not explicitly addressed include:

- Lighting and shadow effects that introduce risk in moving the robotic arm, and therefore may extend the time to consider the current and planned robotic arm position relative to structure and EVA position; and may impact the control mode used, and speed at which the robotic arm is operated.
- Crew attention is required to assess whether the robotic arm is moving as it should be. While this model included a monitoring function and camera control, more detailed observations of this particular task would be necessary to fully appreciate the mental workload associated with the crew’s need to perceive and evaluate off-nominal conditions (e.g., ‘sluggish joints’) and maintaining contingency plans for possible off-nominal circumstances.
- Some SSRMS configurations have more instability than others, and in some cases, this is unexpected and can result in poor camera views. One early ISS crewmember indicated "with the pump module it was more (in)balance in the system than they were expecting, so much so that the field of view was going outside of the view of the camera (Crew Comment Database Inquiry, 2023).
- M1/M2 SMEs conveyed that one of the challenges for robotic arm operations is the management of various perspectives and frames of reference. They take it as an additional task to convert other frames of reference (e.g., JOCAS’ robotic arm joint configuration) into that which is most relevant to the EVA crewmember. Not only is this comforting to the EVA-crewmember on the Robotic Arm so they can predict

their movement direction and orientation, but this also ensures that their direct observations can be more quickly understood by M1/M2. Conducting this type of four-dimensional translation task induces considerable workload.

5. While the contexts of models described M1's task demands with respect to automation capabilities and other available crew, the impacts of the workload induced to other agents is not an output of this form of model. Where M1 tasks are shed, companion models of other crew would need to be constructed to indicate the effects on those crewmembers and determine the likelihood that a task may not be performed at all given other crewmembers' workload. Other models in this effort (EVA Model) have shown this multi-crew analysis, but at a higher level of analysis and not specifically with respect to automation capability variants.
6. This model assumes that the crew, particularly the robotic arm operator, will have sufficient training and recency of use to perform robotic arm operations without access to ground control personnel. Interviewed SMEs suggested that M1s have different manual operating speeds, reflecting nature and skill level. Such skills are not only manual control but include maintenance of an accurate mental model of automation/robotic capabilities and methods of interaction, health management (failure detection, diagnosis and response/mitigation) of the automated/robotic system, interface dialog semantics and semiotics, and all of these for ancillary tasking (e.g., communications, procedure use) supporting these. Additionally, SMEs indicated that operations for long duration space missions will require additional investment in crew training devices and IV scheduled crew time to ensure skills are maintained during space missions. When one crewmember was asked to compare a simulation environment and operations at the robotic workstation in the Cupola, s/he indicated that they could not comment because too much time had passed between the simulation and activity (Crew Comment Database Inquiry, 2023). Crew commented that training should also include scenarios that go beyond the manual operations and clearance keeping, where the full crew is in the scenario "where everyone is trying to work together to get the job done and it's hard to do it safely. So understanding the CRM aspect of that, (e.g.,) how you use an M2 or how you interact with EV." These observations underscore the necessity of periodic operational training, and that this training should not be limited to the skill-based aspects of conducting robotic arm operations.
7. This model's outputs the workload experienced by M1, and the time to perform the required tasks. This effort did not model human error, the acquisition and maintenance of situation awareness, or the ability to perceive necessary information from the environment. Sufficient data was not available to support detailed model enhancements in these areas although narrative input collected from SMEs indicated that an M1 operating robotic arm without M2 support would be expected to be more error prone. A comment from an early Expedition noted that it was difficult to manage the Robotic Arm, performing as an M1 and manage the rest of the vehicle – "The IV crew must be at three places at once." This was said to be especially challenging when a system failure occurs (Crew Comment Database Inquiry, 2023).
8. The current model presumes that the interfaces available for the M1 to control the Robotic Arm are as they exist on the ISS, and the capability of the robotic arm controlling automation is generally as is available on the SSRMS/Canadarm2. The current model deviates from these assumptions in a few ways. While in current ISS operations, manual and automated modes

are used back and forth to achieve an end during EVA operations. This model uses manual or automation mode for the mission unless the automated mode fails. Currently robotic arm operations proximal to the worksite are often Pure GCA adjustments, where the M1 and the EVA-on-the-robotic arm communicate to make adjustments as necessary for visual and physical access in either mode. In this model, the automated (i.e., JOCAS) operations assume automated adjustment—slowing when proximal to worksite, but not involving the crewmember as the controlling entity. This model does assume an advanced version of automated control that is allocated more control responsibility than the existing version. SME Interviews suggest various forms of technological advancement to the IV crew interfaces to control the robotic arm and to the capabilities of the robotic arm itself. Some of those mentioned include more robust automated movement such that automated movement is permitted even when close to structure (e.g., collision detection and avoidance) and when visual clearances are not available, more sophisticated alerting, assistance with camera and lighting to improve visualizing robotic arm position, vehicle structure and EVA crew, and even direct control interfaces to be used by the EVA crewmember on the robotic arm. The model allows full automated control throughout a mission, with the assumption that enough finite position sensing, and collision avoidance sensing, is available to allow for this. Ambient conditions and peripheral design features at the Robotic Workstation also may affect performance. For example, the Crew Comments Database also indicated the importance of postural support at the robotic workstation to ensure effective loads for manual control.

Further, this model focused on the impact of alternative levels of robotic autonomy, trust (inversely modeled as expectation of failure) and alert salience on M1 performance and mental workload when automated operations of the robotic arm failed.

#### **7.2.3.4 Results and Discussion**

Per the methodology outlined in the “Model Variables, Versions, and Analysis Plan” subsection of the “7.2.3.2 Methods and Procedures Methods” main section of this report, many versions of the model were built and executed to collect data to perform many different comparative mental workload and mission time analyses. This section first summarizes each of these comparative analyses, then discusses the meaning of the results with findings and associated recommendations.

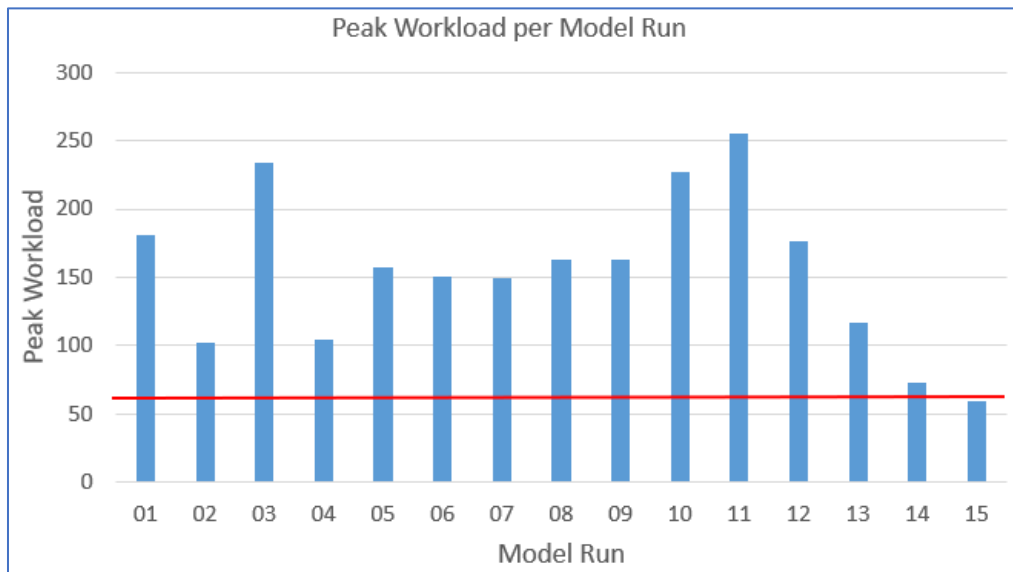
#### **Analysis Results**

##### **Overview of Analyzed Runs**

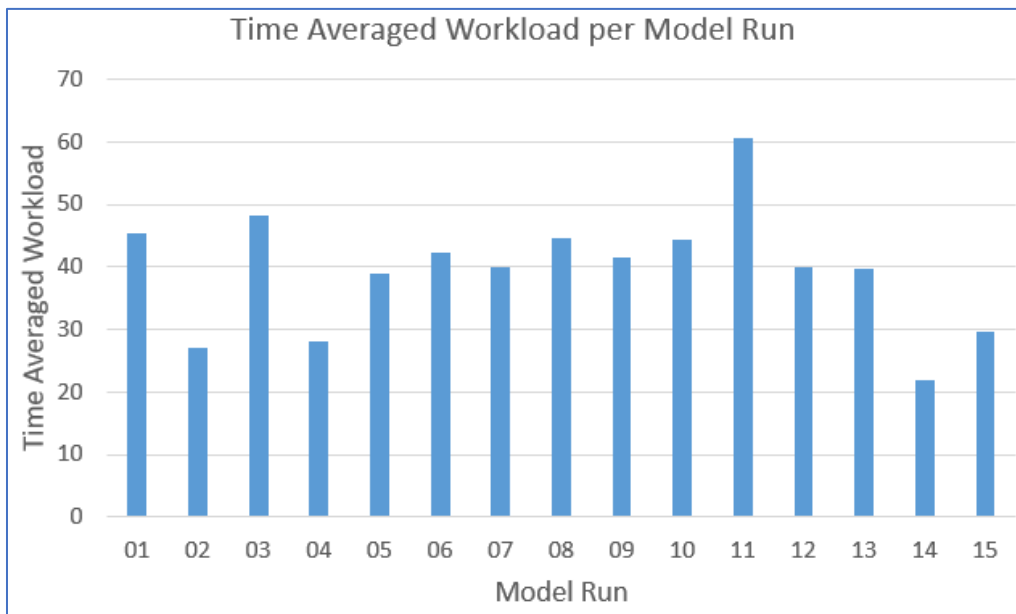
IMPRINT provides several built-in reports for operational model runs. Several of those reports were utilized, and some expanded, to feed the team’s model analyses. One of these reports is a chart showing operator workload over time. An analyst can quickly look at this chart to see if an operator is predicted to have high workload spikes above the MRT redline of 60, how high the spikes go, how often they may occur, and how dense overall mental workload attentional demands are over the course of a mission. The highest workload peak for every mission run in this analysis are shown in Figure 68. These workload over time reports can also be collaborated with another report, the operator workload detail report, that shows which tasks the operator was performing that led to changes in overall workload at every event time stamp of model execution. For this set of model analyses, the team has selected workload peaks and used the

workload detail report to discover, and report, which tasks were being performed simultaneously that caused the highest workload peaks in different model runs.

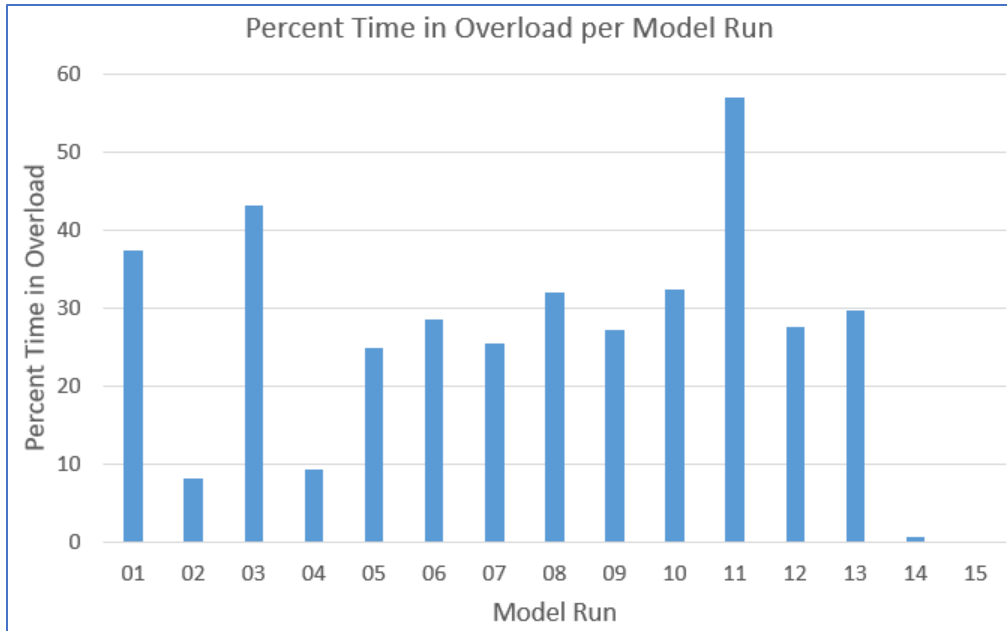
IMPRINT also allows an analyst to generate a report of all data used to create the workload over time charts. This data can be parsed and post-processed to determine two other telling workload metrics; time-averaged workload over the course of the mission run and percent time in overload. These metrics were also used as a part of this model's detailed workload analysis. These two additional workload metrics are shown for all model runs in Figures 69 and 72.



**Figure 68. Peak Workload for Every Model Run**

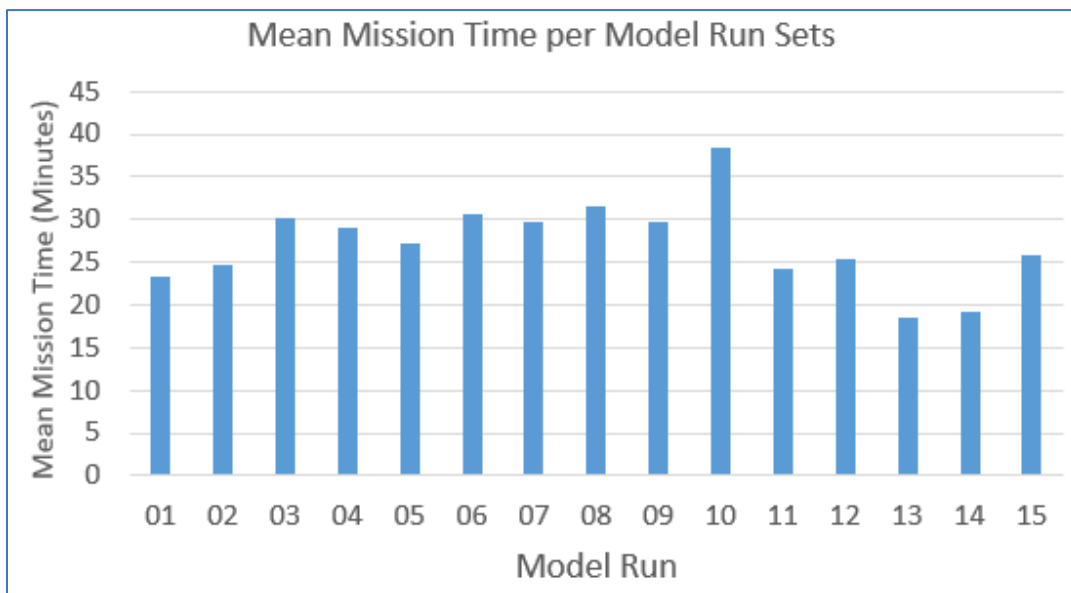


**Figure 69. Time-Averaged Workload for Every Model Run**

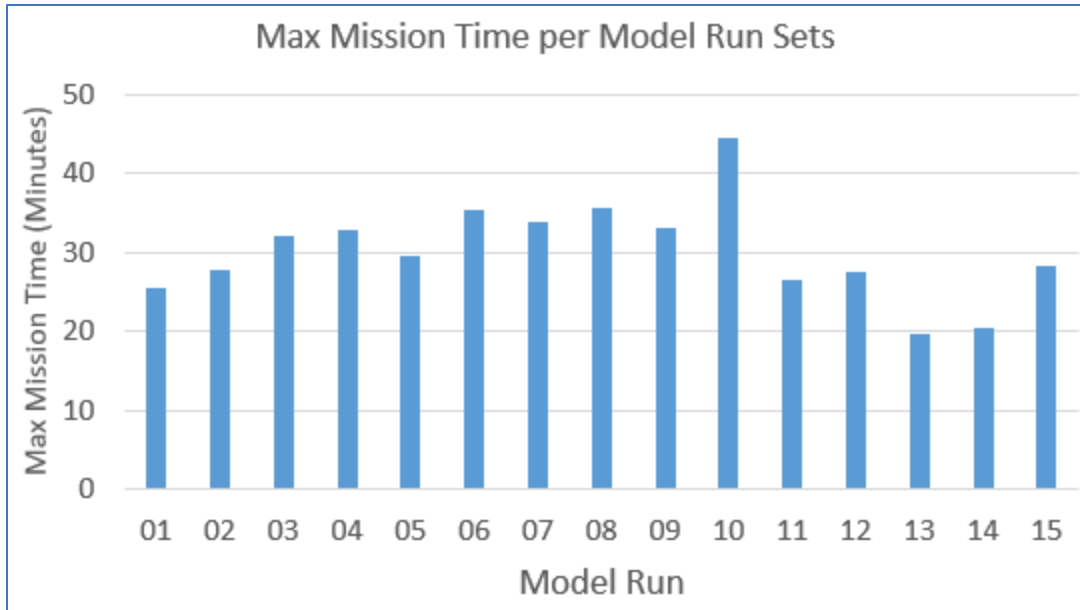


**Figure 70. Percent Time in Overload for Every Model Run**

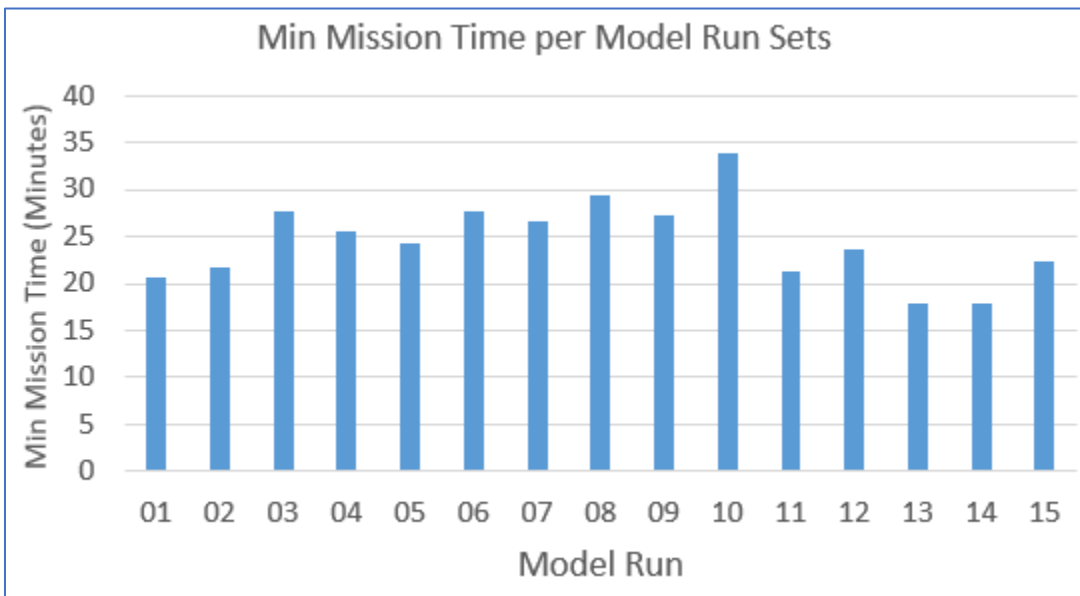
Other built-in model reports capture mission (each modeled scenario is a “mission” in IMPRINT terminology), function, task timing information associated with multiple model executions (our team chose 30 to analyze a large set of output data for runs with different initial random number seeds) for each run set, and data (e.g., mission executions time means, maximums, and minimums). Additionally, these reports were used to derive the mean time spent moving the robotic arm (where higher workload typically occurred, especially during manual operations). These metrics are summarized for all model runs in Figures 71 through 74.



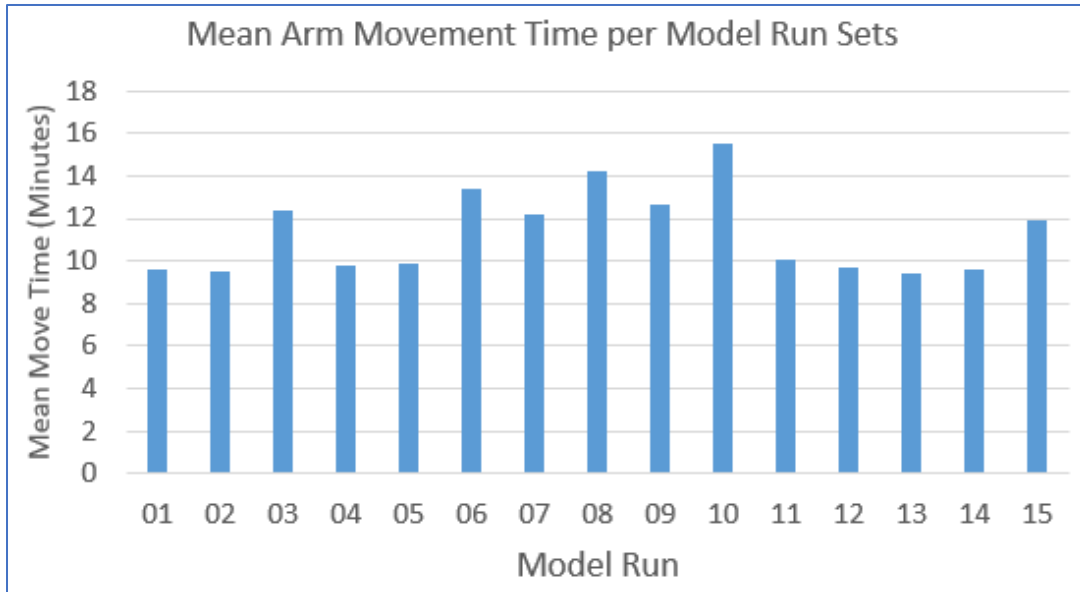
**Figure 71. Mean Mission Time per Model Run Sets**



**Figure 72. Maximum Mission Time per Model Run Sets**



**Figure 73. Minimum Mission Time per Model Run Sets**



*Figure 74. Total Robotic Arm Movement Time per Model Run Sets*

**Comparative Data Analyses:**

For the remainder of this section, additional comparative analyses delineated in Table 25 will be examined in more detail. This analysis will include the workload over time reports for each model run, examples of simultaneous tasks performed during workload peaks, and tables and charts comparing the metrics discussed above but more specific to the comparisons. For the comparative workload tables, a color scheme mapping workload values to the stoplight chart from the Bedford scale (discussed in Section 7.2.1), shows how the levels of workload may impact task performance. For discussion purposes, the colors mapped to the logic in that section can also be mapped as follows according to possible impact on task or scenario performance: Green equates to acceptable workload, Yellow equates to high workload, and Red equates to unacceptably high workload.

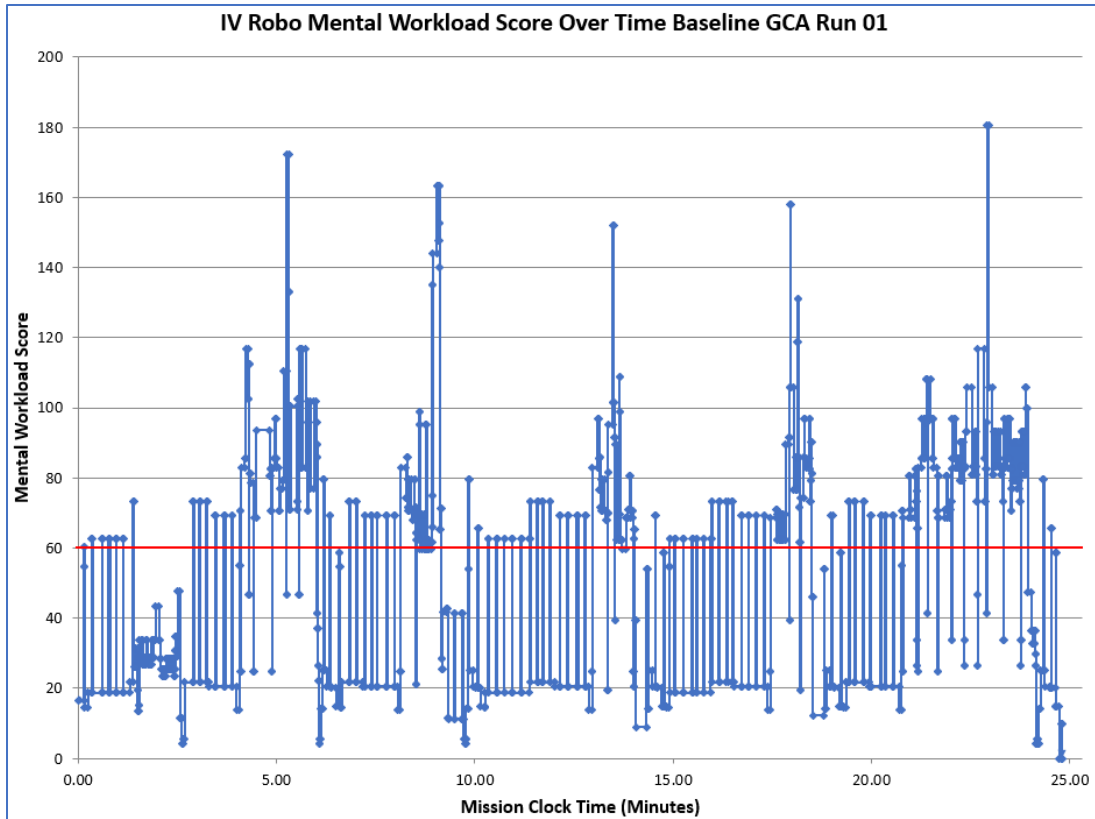
**Analysis 1:**

Comparison of M1 using manual (GCA) control (run 01) vs automated (JOCAS) control mode (run 02).

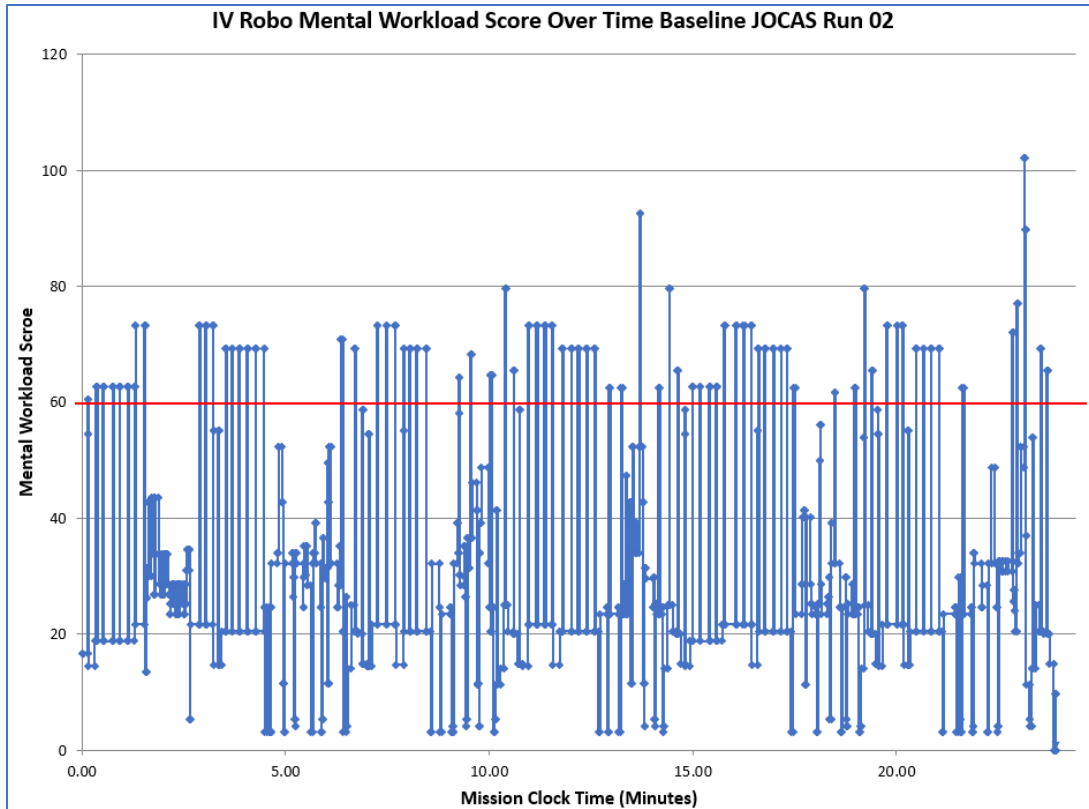
**M1 Mental Workload comparisons:**

The full workload charts, over time, for one representative mission run for each mode is shown in Figures 75 and 76. Tables 25 and 26 show workload peaks for each mode of operations and associated concurrent tasks being performed by the M1. NASA robotic arm control SMEs vetted the fact that these task concurrences were possible.





*Figure 75. Workload Over Time for Baseline GCA Run 01*



**Figure 76. Workload Over Time for Baseline JOCAS Run 02**

**Table 25. Tasks Concurrently Performed at Peak Workload Values Run 01**

Mission Time (Min)	Workload Score	Simultaneous Tasks
22.91	180.48	Change camera view GCA LongComm_Listen Monitor robotic arm camera views (manual mode close to end) Twist right stick (vertical robotic arm control)
5.26	172.21	Change camera view GCA LongComm_Speak Monitor robotic arm camera views (manual mode) Twist right stick (vertical robotic arm control)

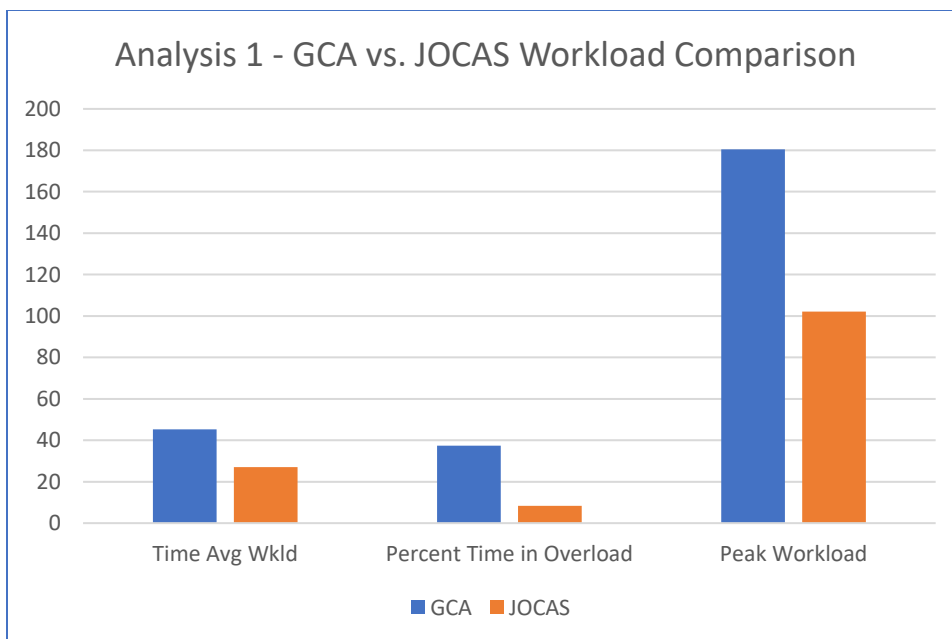
**Table 26. Tasks Concurrently Performed at Peak Workload Values Run 02**

Mission Time (Min)	Workload Score	Simultaneous Tasks
23.14	102.16	Change camera view JOCAS LongComm Listen Monitor positioning data (J)
13.69	92.50	JOCAS LongComm_Speak Monitor positioning data (J) Push button on left stick to change robotic arm speed

The higher and more dense workload peaks shown in Figure 75 illustrate mental workload during periods of robotic arm movement in the GCA mode. The two workload charts also show that workload peaks are significantly higher in GCA mode versus JOCAS (note that the charts are on different scales, with the redline of 60 shown on each chart). Average workload during robotic arm movement in the GCA mode is significantly higher than that experienced during JOCAS operations, with a time-averaged workload during these periods over 2.5 times greater. This was the primary driving factor associated with higher overall workload in GCA modes versus JOCAS modes. A summary of workload metrics associated with this comparative analysis is shown in Table 27. This same data is shown in a bar chart in Figure 77.

**Table 27. Workload Metric Comparison Analysis 1**

Run No. – Brief Model Description	Time-Avg Workload	Percent Time in Overload	Peak Workload
<b>01 GCA</b>	45.25	37.38	180.48
<b>02 JOCAS</b>	27.05	8.32	102.16



**Figure 77. Workload Metric Comparison Analysis 1**

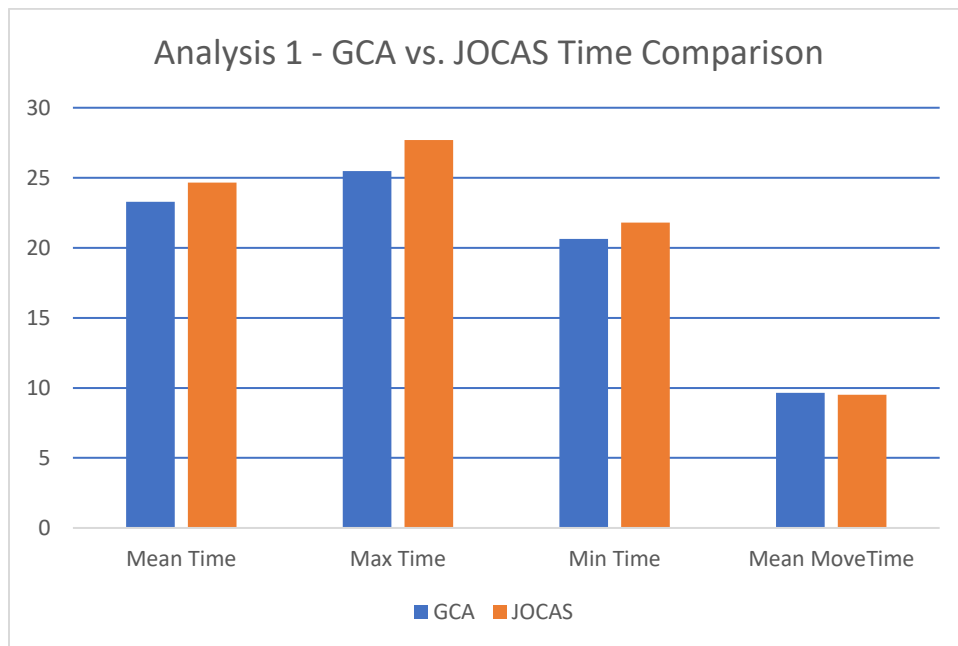
The most significant overall workload difference between GCA (manual) robotic arm operations and JOCAS (automated) mode is the percent time in overload (above the workload threshold of 60). The M1 robotic arm operator spends almost 4.5 times more in overload in GCA mode, with most of that occurring during robotic arm movement operations.

**Mission Time Comparisons:**

Mission time differences were negligibly different between GCA and JOCAS operations. Sometimes differences (slightly more time for JOCAS) were due to slightly higher pre-move segment times for a few JOCAS tasks. Other small differences in mission times were more driven by different robotic arm speeds than by human performance. The mission time comparisons for GCA versus JOCAS are shown in Table 28 and Figure 78.

*Table 28. Mission Time Comparison Analysis 1*

Run No. – Brief Model Description	Mean Time	Max Time	Min Time	Mean Move Time
01 GCA	23.28	25.48	20.63	9.64
02 JOCAS	24.65	27.69	21.80	9.51



*Figure 78. Mission Time Comparison Analysis 1*

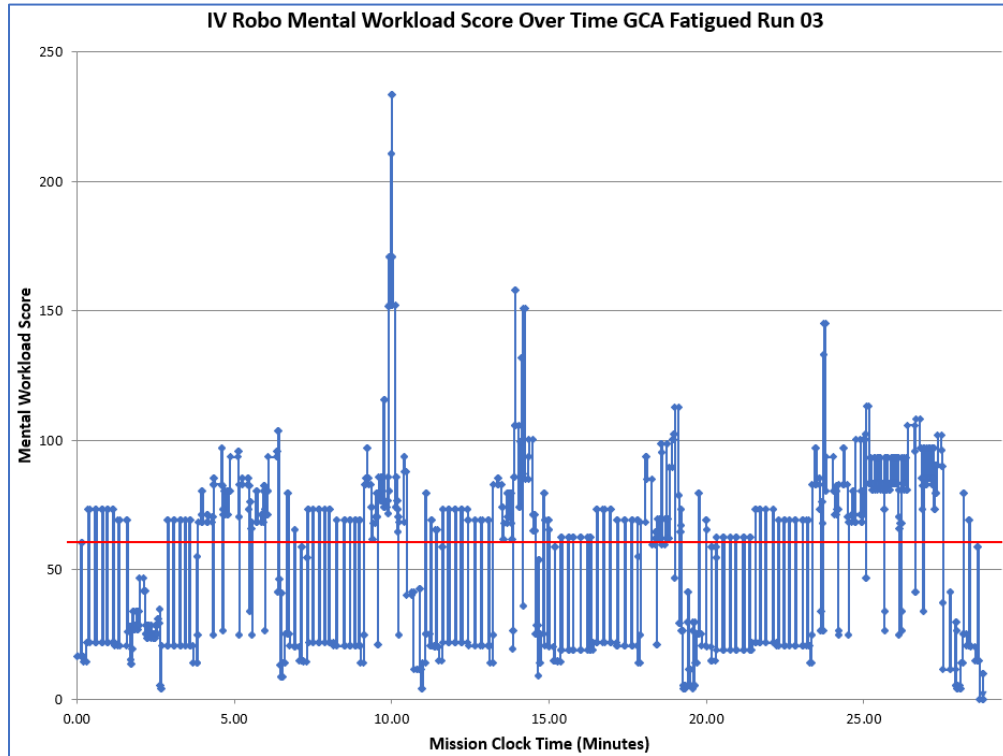
**Analysis 2:**

Comparison of M1 using manual (GCA) control and automated (JOCAS) control mode while fatigued (assuming sleep deprivation of 4 hours of sleep per night for the previous four nights prior to mission performance, runs 03 and 04) versus the baseline non-fatigued models.

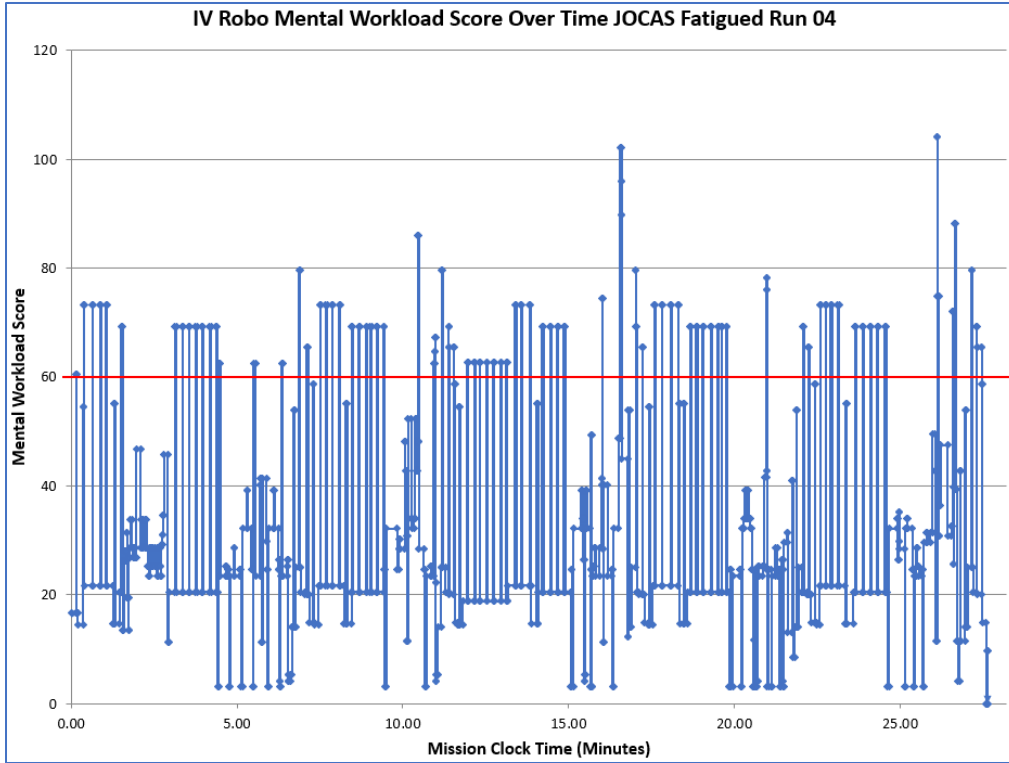
**M1 Mental Workload Comparisons:**

The full workload charts, over time, for one representative mission run for each fatigued mode are shown in Figures 79 and 80. Tables 29 and 30 show workload peaks for each mode of operations and associated concurrent tasks being performed by the M1. NASA robotic arm

control SMEs vetted the fact that these task concurrences were possible. While fatigue made little difference in the workload profiles and peaks during JOCAS operations (comparing the charts shown in Figures 80 and 76), there were some significantly higher workload peaks during fatigued operations when GCA control was being utilized (comparing Figures 79 and 75). This is due to the potential for more brief periods of added multi-tasking, including five simultaneous tasks with some short and minor, but adding to overall workload due to the conflict component of MRT) as shown in Table 29.



*Figure 79. Workload Over Time for Fatigued GCA Run 03*



**Figure 80. Workload Over Time for Fatigued JOCAS Run 04**

**Table 29. Tasks Concurrently Performed at Peak Workload Values Run 03**

Mission Time (Min)	Workload Score	Simultaneous Tasks
10.01	233.55	GCA ShortComm Speak Monitor positioning data Move left stick to avoid hazards/contacts Move right stick sideways (horizontal robotic arm control) Push button on left stick to change robotic arm speed
9.99	210.80	GCA ShortComm_Speak Monitor positioning data Move left stick to avoid hazards/contacts Move right stick sideways (horizontal robotic arm control) Push button on left stick to change robotic arm speed

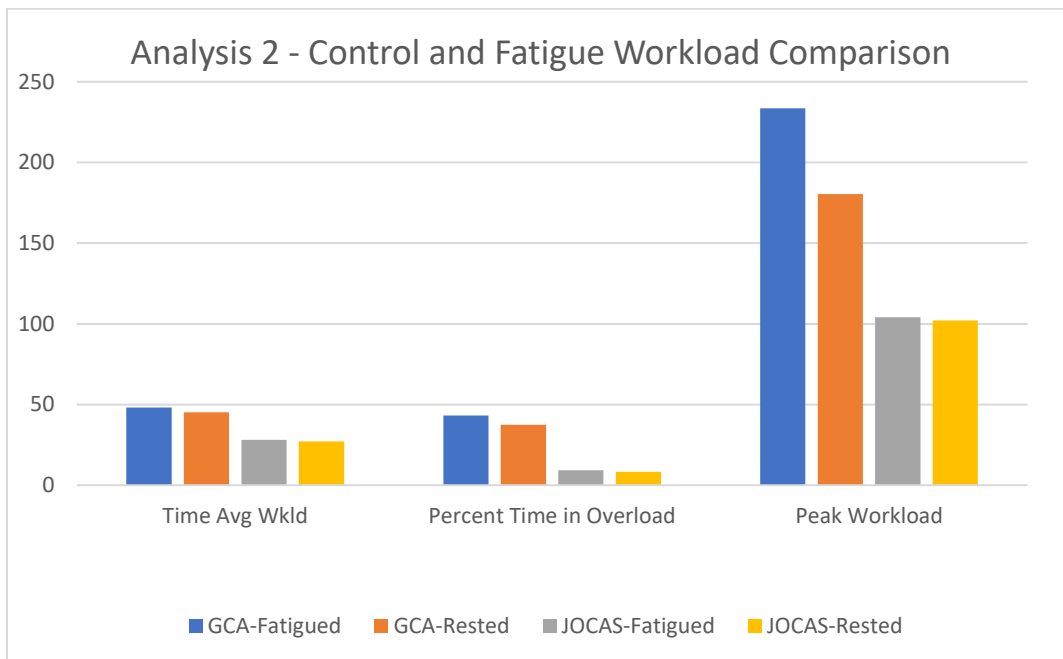
**Table 30. Tasks Concurrently Performed at Peak Workload Values Run 04**

Mission Time (Min)	Workload Score	Simultaneous Tasks
26.12	104.12	Change camera view JOCAS LongComm Speak Monitor robotic arm camera views (JOCAS close to end)
16.55	102.16	Change camera view JOCAS LongComm_Listen Monitor positioning data (J)

The summary workload data comparison charts shown in Table 31 and Figure 81 show moderate increases in time-averaged workload for GCA and JOCAS operations under fatigued conditions. However, due to higher workload peaks (from more multi-tasking overlap during GCA fatigued conditions), there are significant increases in percent time in overload (43.2 versus 37.4) and peak workload.

**Table 31. Workload Metric Comparison Analysis 2**

Run No. – Brief Model Description	Time-Avg Workload	Percent Time in Overload	Peak Workload
<b>03 GCA-Fatigued</b>	48.23	43.23	233.55
<b>01 GCA-Rested</b>	45.25	37.38	180.48
<b>04 JOCAS-Fatigued</b>	28.08	9.31	104.12
<b>02 JOCAS-Rested</b>	27.05	8.32	102.16



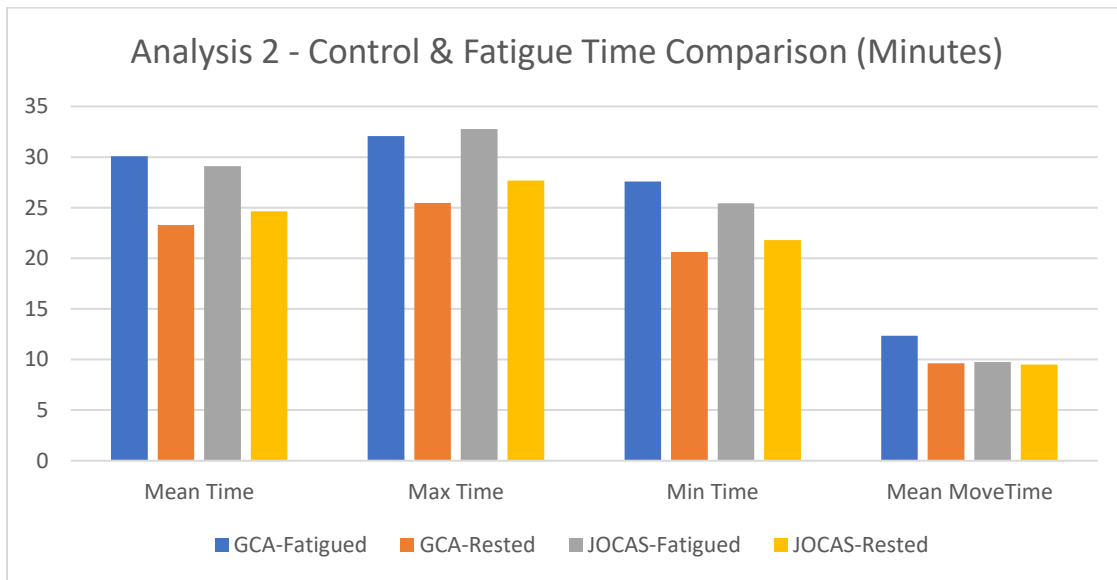
**Figure 81. Workload Metric Comparison Analysis 2**

**Mission Time Comparisons:**

Mission time differences were noticeable due to fatigue effects for GCA and JOCAS operations, but the time impacts associated with GCA were higher. This was largely due to a large increase in robotic arm movement time due to fatigue impacts. The mission time comparisons for fatigued GCA and JOCAS operational runs 03 and 04 versus baseline models without fatigue are shown in Table 32 and Figure 82.

*Table 32. Mission Time Comparison Analysis 2*

Run No. – Brief Model Description	Mean Time	Max Time	Min Time	Mean MoveTime
03 GCA-Fatigued	30.08	32.08	27.59	12.33
01 GCA-Rested	23.28	25.48	20.63	9.64
04 JOCAS-Fatigued	29.11	32.77	25.45	9.75
02 JOCAS-Rested	24.65	27.69	21.80	9.51



*Figure 82. Mission Time Comparison Analysis 2*

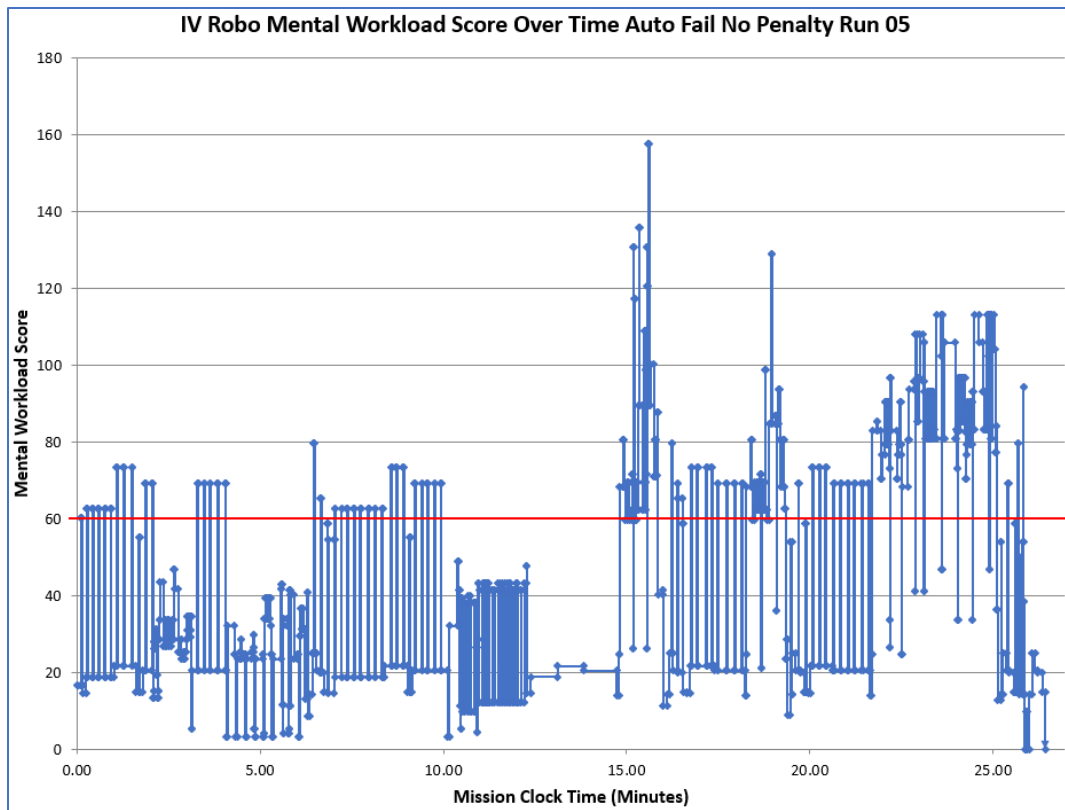
**Analysis 3:**

Comparison of M1 using JOCAS control with an automation failure scripted (run 05) versus baseline JOCAS without an automation failure scripted (run 01).

**M1 Mental Workload Comparisons:**

The full workload chart, over time, for one representative mission run of the scripted automation failure is shown in Figure 83. Table 33 shows workload peaks for this model run. The peaks are much greater than the baseline JOCAS model because after automated robotic arm control starts to fail, and troubleshooting steps are performed, the M1 robotic arm operator switches to manual control.





**Figure 83. Workload Over Time for JOCAS with Scripted Failure Run 05**

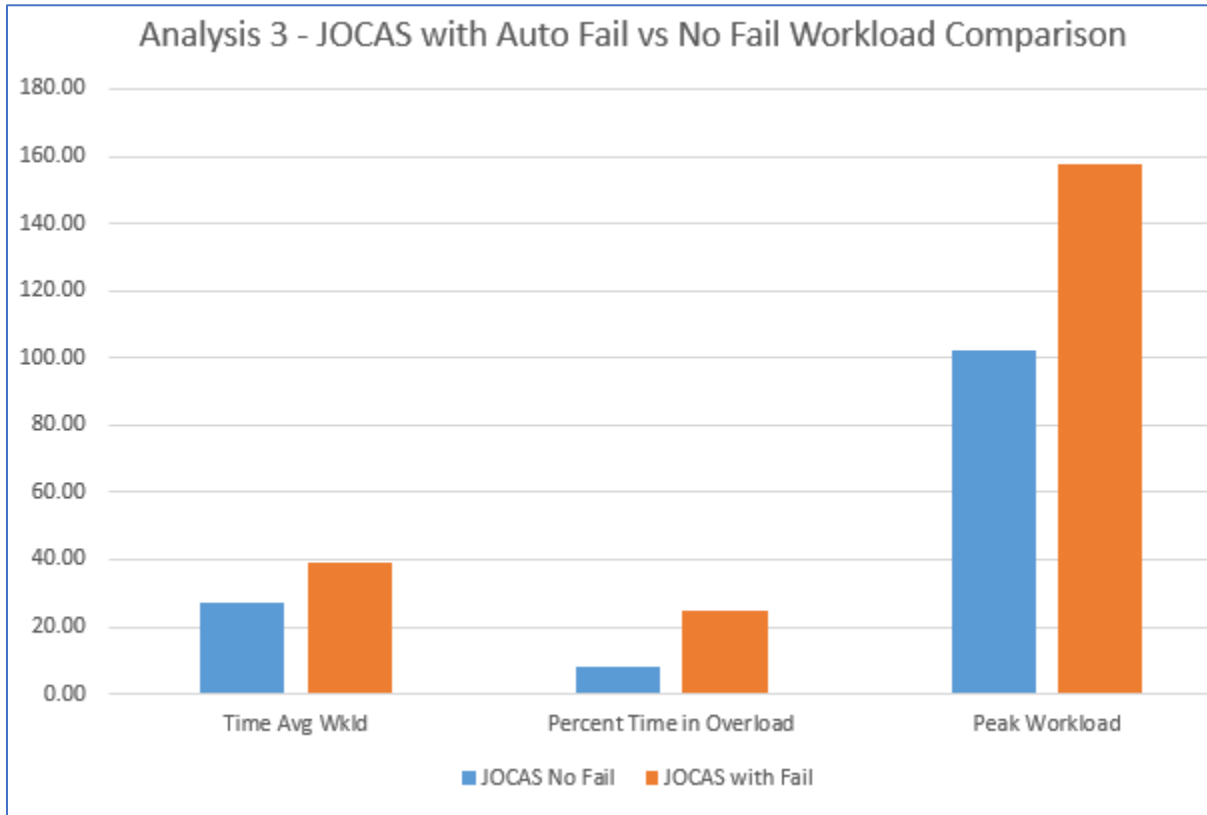
**Table 33. Tasks Concurrently Performed at Peak Workload Values Run 05**

Mission Time (Min)	Workload Score	Simultaneous Tasks
15.59	157.76	Change camera view GCA LongComm_Speak Monitor robotic arm camera views (manual mode) Move right stick sideways (horizontal robotic arm control)
15.34	135.83	GCA LongComm_Speak Monitor robotic arm camera views (manual mode) Move right stick sideways (horizontal robotic arm control) Push button on left stick to change robotic arm speed

A summary of workload metrics associated with this comparative analysis is shown in Table 34. This same data is shown in a bar chart in Figure 84. All workload metrics increase significantly for the automation failure scenario due to the switch to manual control mode. These include an almost 3 times increase in time spent in overload.

**Table 34. Workload Metric Comparison Analysis 3**

Run No. – Brief Model Description	Time-Avg Workload	Percent Time in Overload	Peak Workload
05 JOCAS with Fail	38.81	24.93	157.76
02 JOCAS No Fail	27.05	8.32	102.16



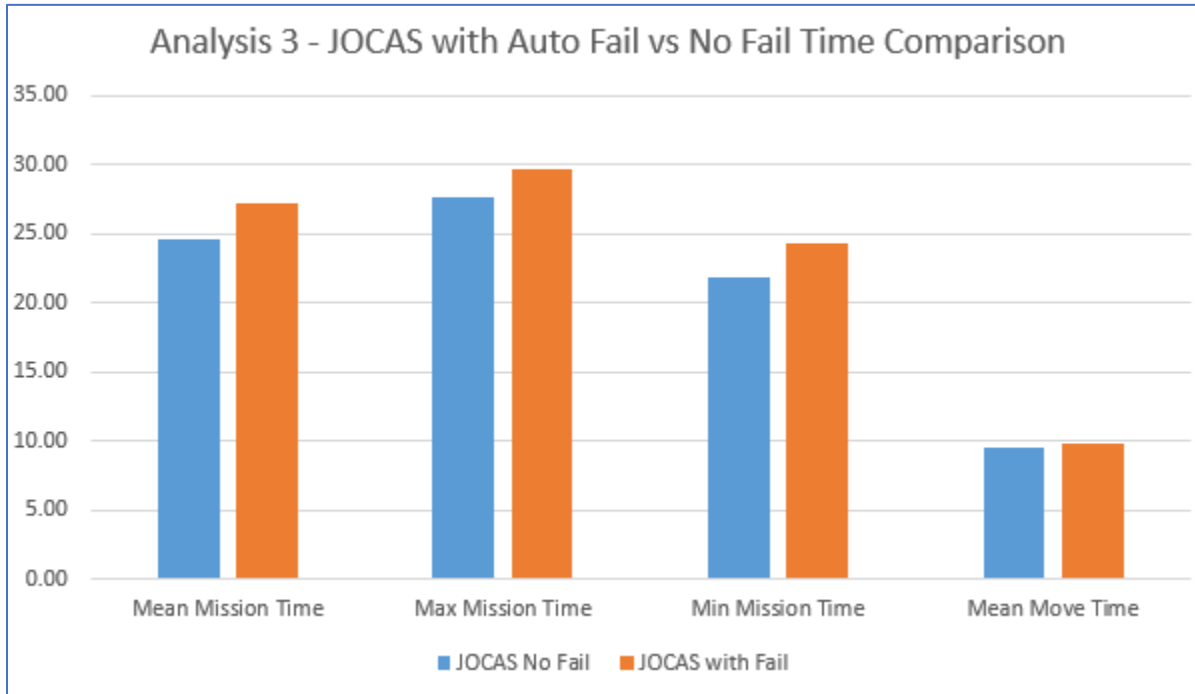
**Figure 84. Workload Metric Comparison Analysis 3**

**Mission Time Comparisons:**

Predictably, mission times increased due to automation control failures. This was mostly due to the addition of troubleshooting tasks. IMPRINT with the S-PRINT installed also allows for the consideration of HAI failure time penalties associated with recovery tasks and certain automation attributes. This analysis, and model run 05, does not include the HAI time penalty. The mission time comparisons for JOCAS with failures (but no time penalties considered) versus baseline JOCAS missions without failures are shown in Table 35 and Figure 85.

**Table 35. Mission Time Comparison Analysis 3**

Run No. – Brief Model Description	Mean Time	Max Time	Min Time	Mean Move Time
05 JOCAS with Fail	27.27	29.68	24.27	9.64
02 JOCAS No Fail	24.65	27.69	21.80	9.51



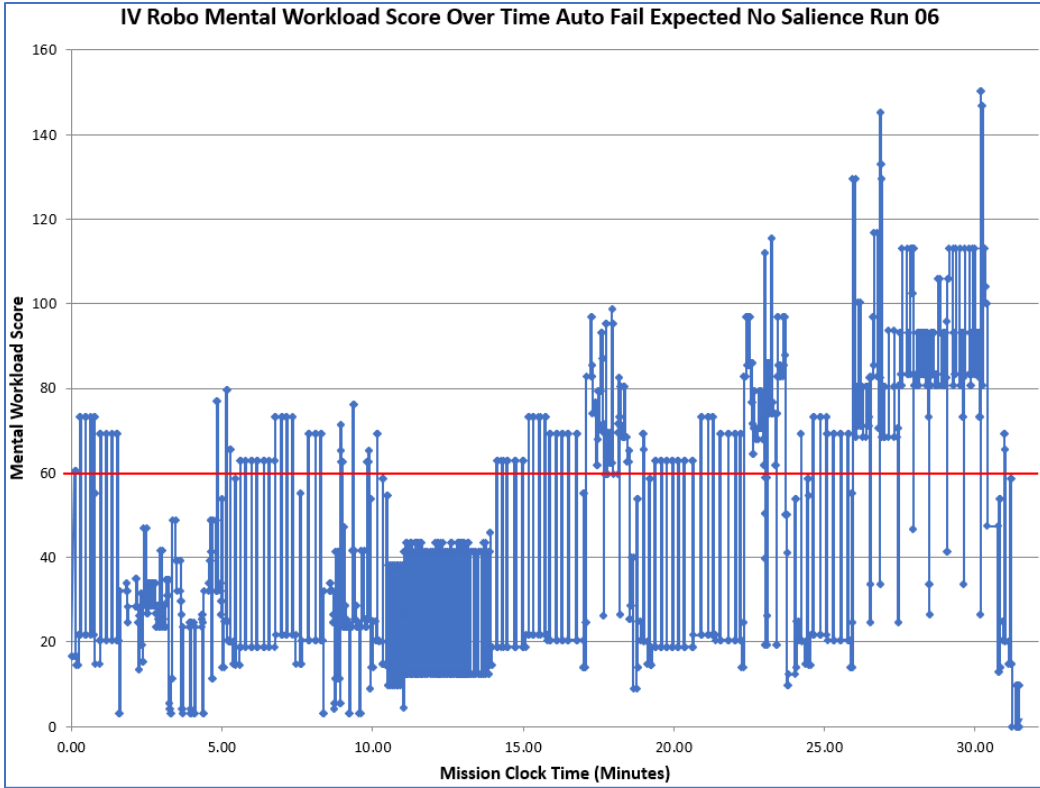
**Figure 85. Mission Time Comparison Analysis 3**

**Analysis 4:**

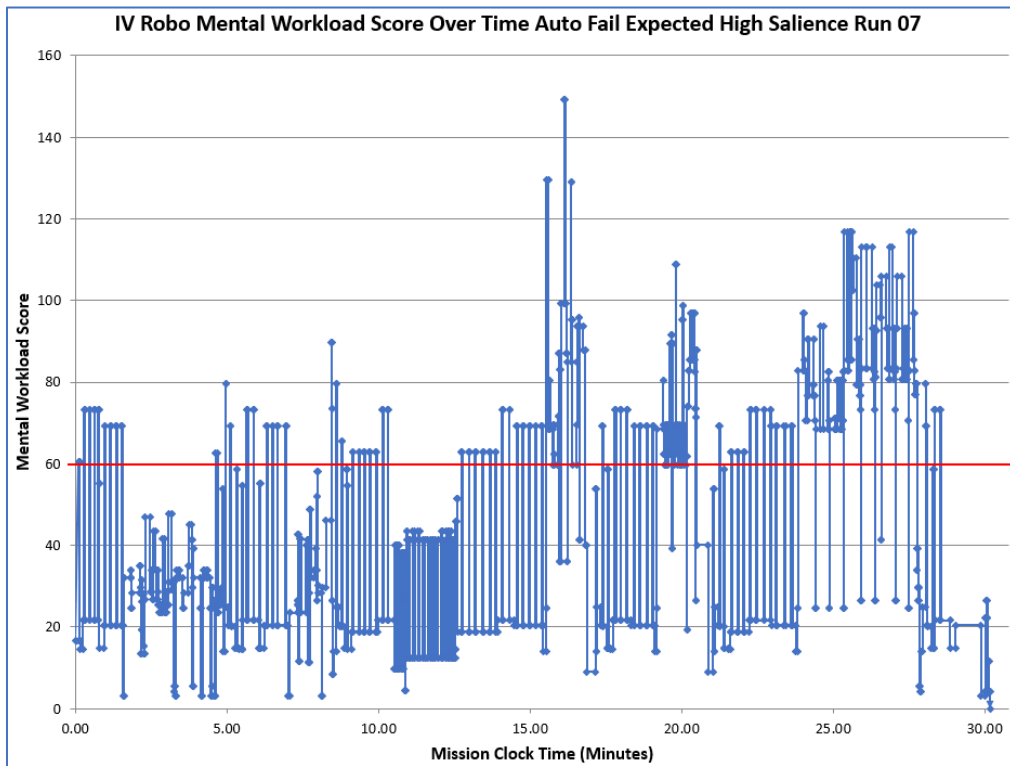
Comparison of JOCAS automation failures with different automation failure attribute effects considered. These attributes included automation failure expectancy, and failure salience, associated with automation robotic arm control failures scripted similar to run 05 but with associated HAI time penalties considered.

**M1 Mental Workload Comparisons:**

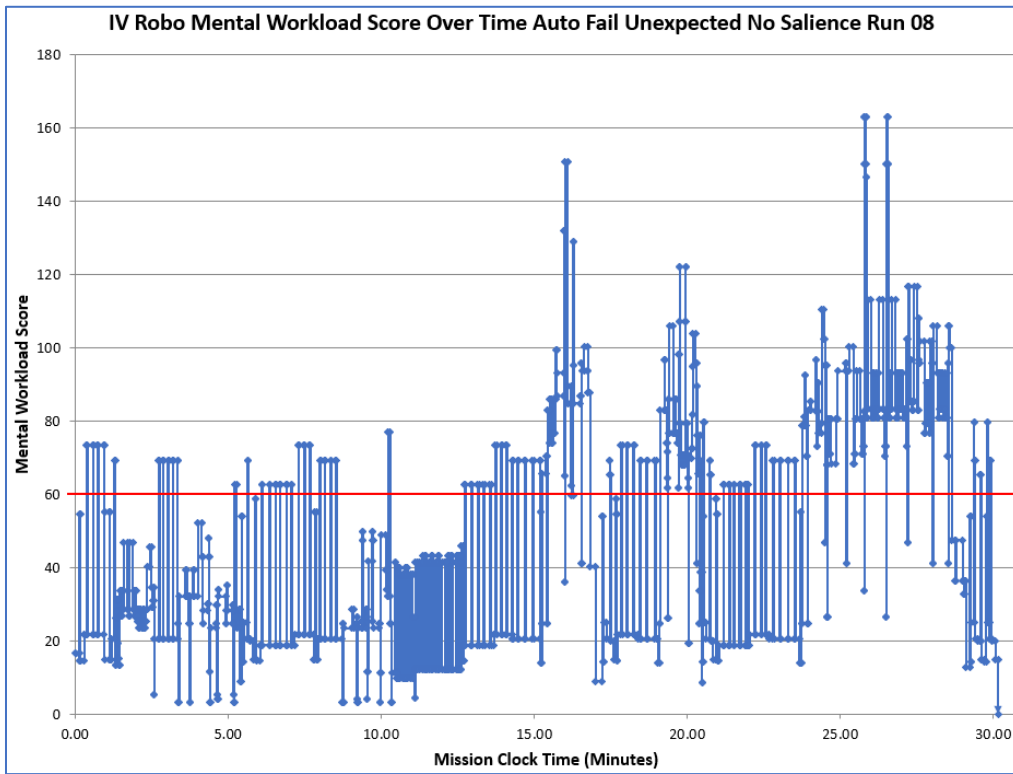
The full workload charts, over time, for one representative mission run for each of the four unique automation failure attribute combinations are shown in Figures 86 to 89. Tables 36 through 39 show workload peaks for each automation failure attribute combination and associated concurrent tasks being performed by the M1.



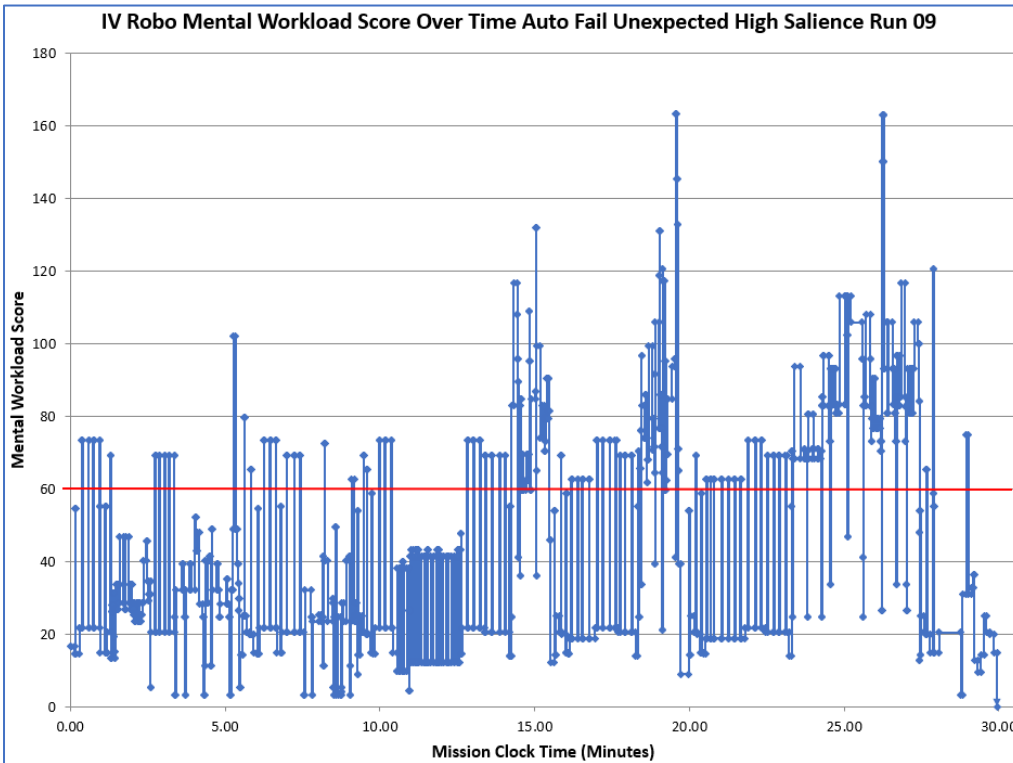
**Figure 86. Workload Over Time for JOCAS with Fail Expected No Salience Run 06**



**Figure 87. Workload Over Time for JOCAS with Fail Expected High Salience Run 07**



**Figure 88. Workload Over Time for JOCAS with Fail Unexpected No Salience Run 08**



**Figure 89. Workload Over Time for JOCAS with Fail Unexpected High Salience Run 09**

**Table 36. Tasks Concurrently Performed at Peak Workload Values Run 06**

<b>Mission Time (Min)</b>	<b>Workload Score</b>	<b>Simultaneous Tasks</b>
30.19	150.19	Change camera view GCA ShortComm_Listen Monitor robotic arm camera views (manual mode close to end) Twist right stick (vertical robotic arm control)
26.85	145.32	Change camera view GCA ShortComm_Speak Monitor robotic arm camera views (manual mode) Twist right stick (vertical robotic arm control)

**Table 37. Tasks Concurrently Performed at Peak Workload Values Run 07**

<b>Mission Time (Min)</b>	<b>Workload Score</b>	<b>Simultaneous Tasks</b>
16.13	149.22	GCA LongComm_Listen Monitor positioning data Move right stick sideways (horizontal robotic arm control) Push button on left stick to change robotic arm speed
15.54	129.57	Change camera view GCA Low level listening Monitor robotic arm camera views (manual mode) Twist right stick (vertical robotic arm control)

**Table 38. Tasks Concurrently Performed at Peak Workload Values Run 08**

<b>Mission Time (Min)</b>	<b>Workload Score</b>	<b>Simultaneous Tasks</b>
26.52	162.98	Change camera view GCA ShortComm_Speak Monitor robotic arm camera views (manual mode close to end) Twist right stick (vertical robotic arm control)
16.01	150.98	Change camera view GCA LongComm_Listen Monitor robotic arm camera views (manual mode) Move right stick sideways (horizontal robotic arm control)

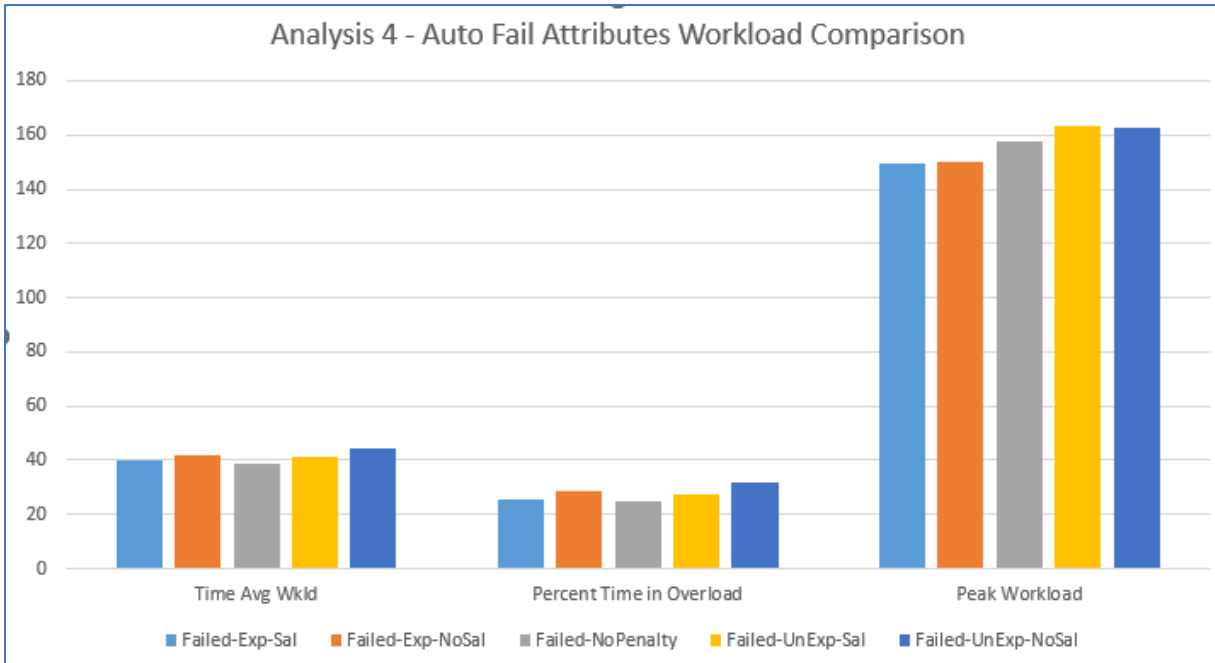
**Table 39. Tasks Concurrently Performed at Peak Workload Values Run 09**

Mission Time (Min)	Workload Score	Simultaneous Tasks
19.56	163.26	Change camera view GCA LongComm_Listen Monitor robotic arm camera views (manual mode) Twist right stick (vertical robotic arm control)
26.23	162.98	Change camera view GCA ShortComm_Speak Monitor robotic arm camera views (manual mode close to end) Twist right stick (vertical robotic arm control)

Although workload profiles differed in times in which high density peaks might occur, the overall profiles and peaks for each case of automation failure were similar. Also, by looking at the workload data shown in Table 40 and associated Figure 90, workload measures were similar across different automation failure attribute settings. As might be predicted, the automation failure with low expectancy (unexpected) and no salience (overall worst-case scenario) had slightly higher time-averaged workload and percent time in overload than the other conditions.

**Table 40. Workload Metric Comparison Analysis 4**

Run No. – Brief Model Description	Time-Avg Workload	Percent Time in Overload	Peak Workload
07 Fail Exp Salient	39.91	25.48	149.22
06 Fail Exp NoSal	42.17	28.64	150.19
05 Fail No Penalty	38.81	24.93	157.76
09 Fail UnExp Salient	41.45	27.27	163.26
08 Fail UnExp NoSal	44.65	32.04	162.98



**Figure 90. Workload Metric Comparison Analysis 4**

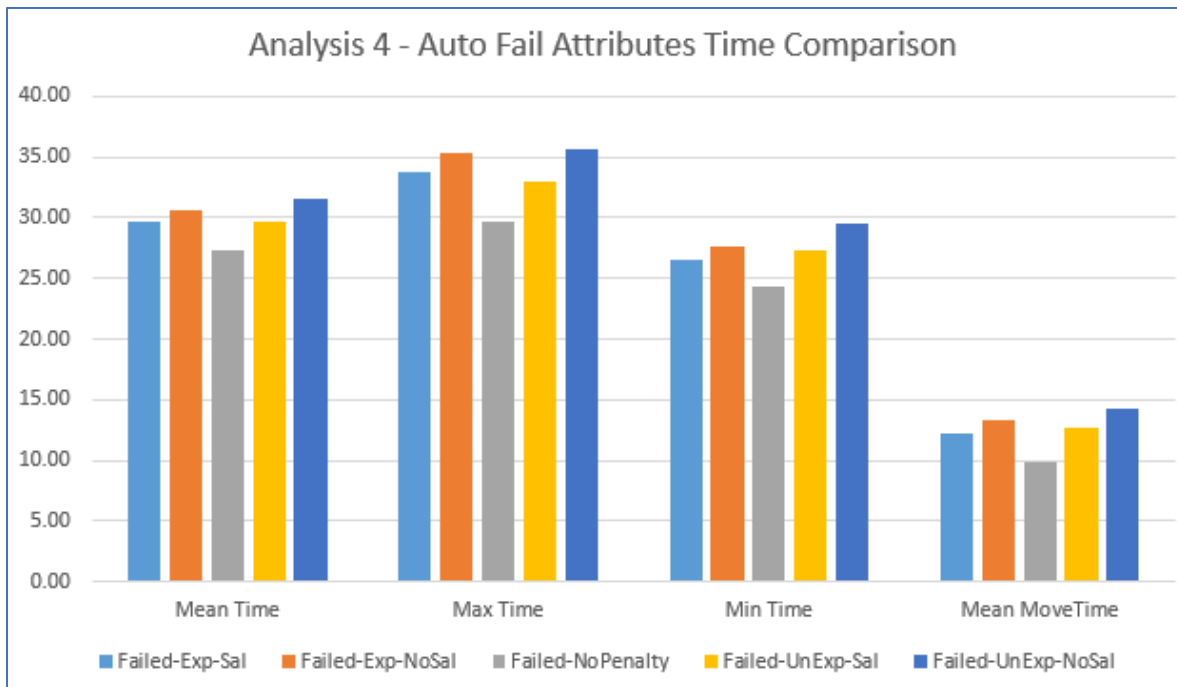
**Mission Time Comparisons:**

Mission time metrics are summarized in Table 41 and Figure 91. Mission times associated with automation control failure scenarios increased due to the automation time penalties associated with the attributes of expectancy (unexpected failures took longer to deal with) and salience (failures with no salience took longer to detect and had more consequences). In the worst-case scenario, that of an unexpected failure that was also not salient, the average mission time increased by 15% over the same control failure set of runs without automation failure time penalties considered.

**Table 41. Mission Time Comparison Analysis 4**

Run No. – Brief Model Description	Mean Time	Max Time	Min Time	Mean MoveTime
07 Fail Exp Salient	29.64	33.82	26.55	12.16
06 Fail Exp NoSal	30.69	35.36	27.58	13.38
05 Fail No Penalty	27.27	29.68	24.27	9.87
09 Fail UnExp Salient	29.64	32.99	27.34	12.69
08 Fail UnExp NoSal	31.57	35.69	29.49	14.24





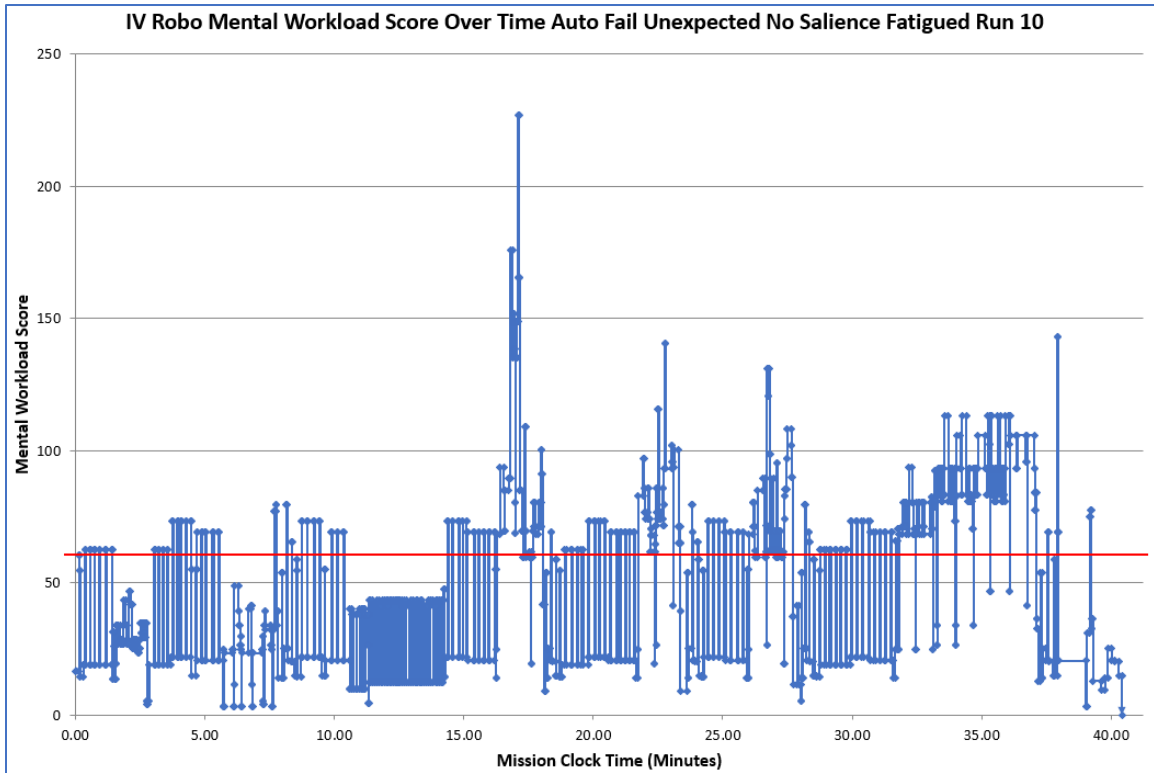
*Figure 91. Mission Time Comparison Analysis 4*

**Analysis 5:**

Comparison of the worst-case automation control failure (unexpected and with low salience) encountered and corrected without fatigue (run 08) versus the same case automation control failure encountered and corrected while fatigued (assuming sleep deprivation of 4 hours of sleep per night for the previous four nights prior to mission performance, run 10).

**M1 Mental Workload Comparisons:**

The full workload chart, over time, for one representative mission run for the fatigued mode of the automation control failure scenario is shown in Figure 92. Table 42 shows workload peaks for this scenario. This scenario is being compared against run 08, whose workload profile is shown in Figure 88.



**Figure 92. Workload for JOCAS with Fail Unexpected No Salience and Fatigue Run 10**

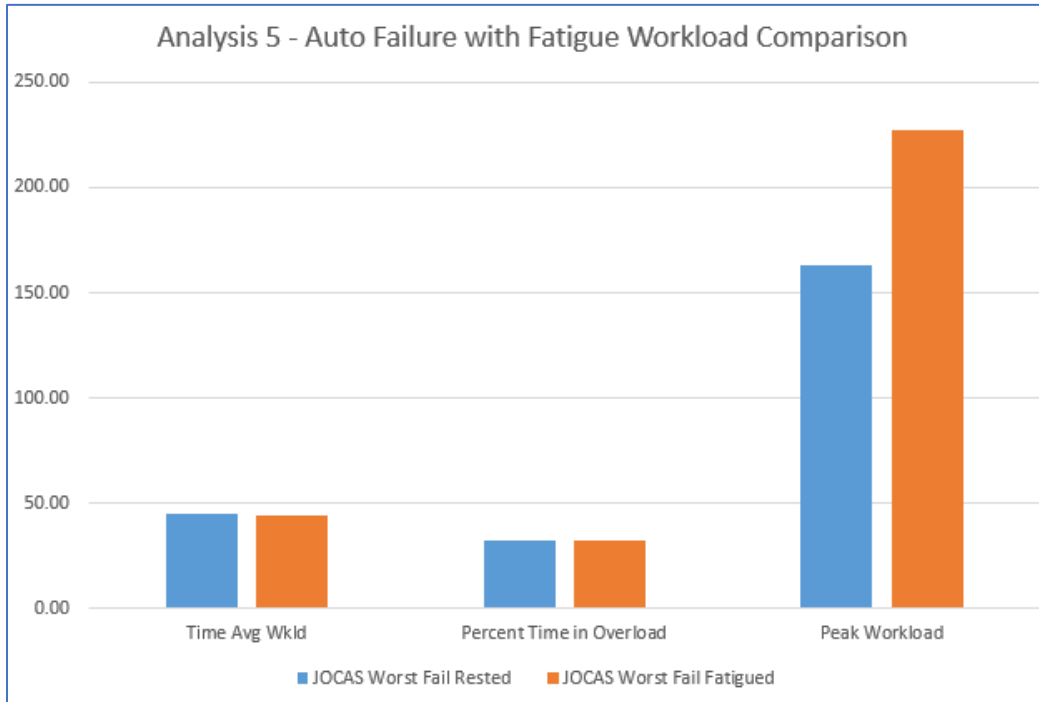
**Table 42. Tasks Concurrently Performed at Peak Workload Values Run 10**

Mission Time (Min)	Workload Score	Simultaneous Tasks
17.10	227.10	GCA LongComm_Listen Monitor robotic arm camera views (manual mode) Move left stick to avoid hazards/contacts Move right stick sideways (horizontal robotic arm control) Push button on left stick to change robotic arm speed
16.81	175.81	GCA LongComm_Speak Monitor robotic arm camera views (manual mode) Move left stick to avoid hazards/contacts Move right stick sideways (horizontal robotic arm control)

The time-averaged workload and percent time in overload are very similar between the worst-case automation control failure experienced while rested and the same failure experienced while fatigued. However, due to one convergence of tasks that include avoiding an obstacle in the fatigued model run, the peak workload is significantly higher. The workload metrics for this analysis are shown in Table 43 and Figure 93.

**Table 43. Workload Metric Comparison Analysis 5**

Run No. – Brief Model Description	Time-Avg Workload	Percent Time in Overload	Peak Workload
<b>08 JOCAS Worst Fail Rested</b>	44.65	32.04	162.98
<b>10 JOCAS Worst Fail Fatigued</b>	44.39	32.49	227.10



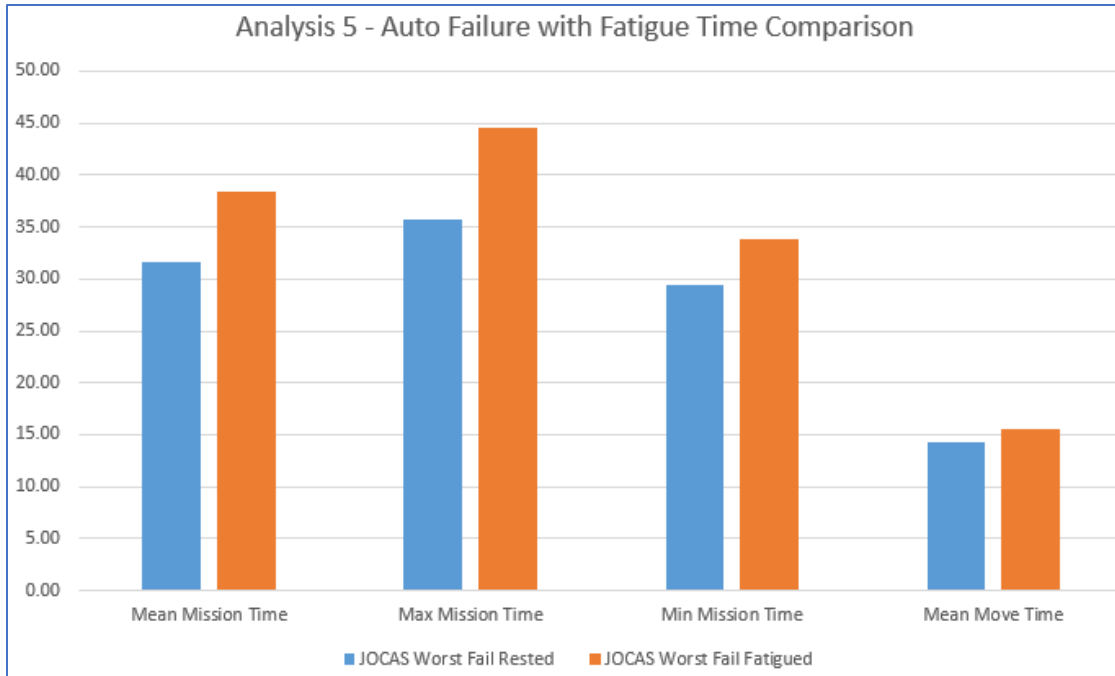
**Figure 93. Workload Metric Comparison Analysis 5**

**Mission Time Comparisons:**

Mission time metrics are summarized in Table 44 and Figure 94. In terms of mission times, the worst-case automation failure experienced while under a fatigue condition was the entire set of analyses worst case scenario. The mean mission time for the fatigued model set of runs, when the M1 robotic arm operator was also dealing with the worst-case scenario automation control failure, was over 20% greater than that for the same scenario without fatigue. This is because the HAI automation failure time penalty and fatigue moderator are impacting task times.

**Table 44. Mission Time Comparison Analysis 5**

Run No. – Brief Model Description	Mean Time	Max Time	Min Time	Mean Move Time
<b>08 JOCAS Worst Fail Rested</b>	31.57	35.69	29.49	14.24
<b>10 JOCAS Worst Fail Fatigued</b>	38.34	44.61	33.89	15.49



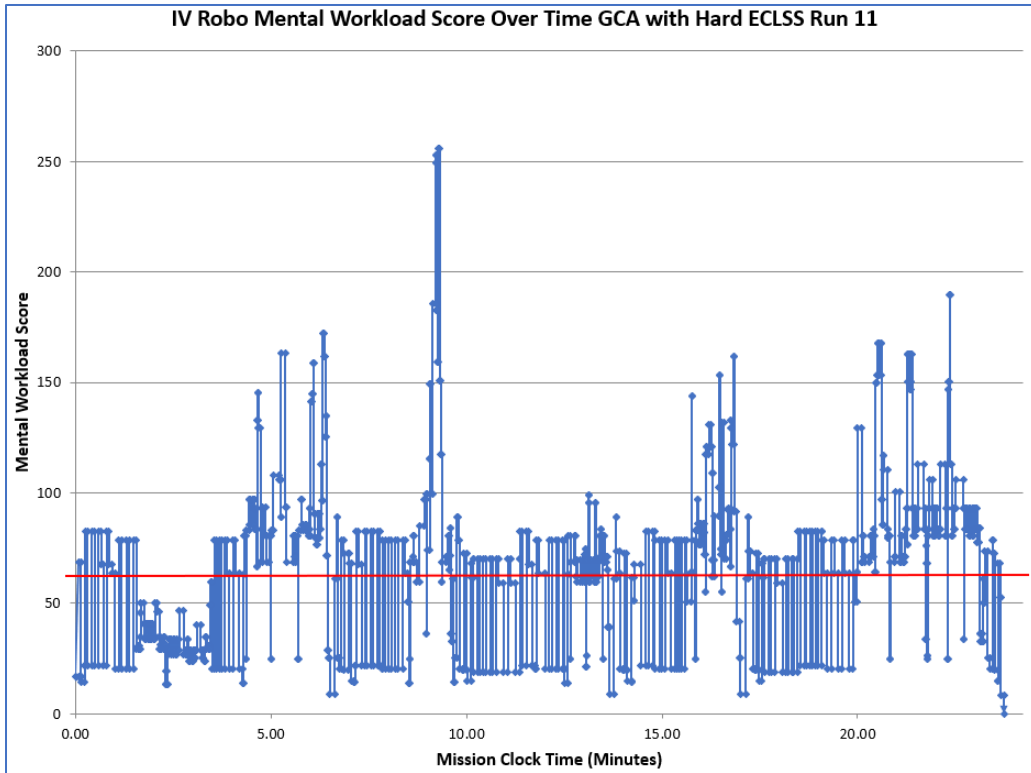
**Figure 94. Mission Time Comparison Analysis 5**

**Analysis 6:**

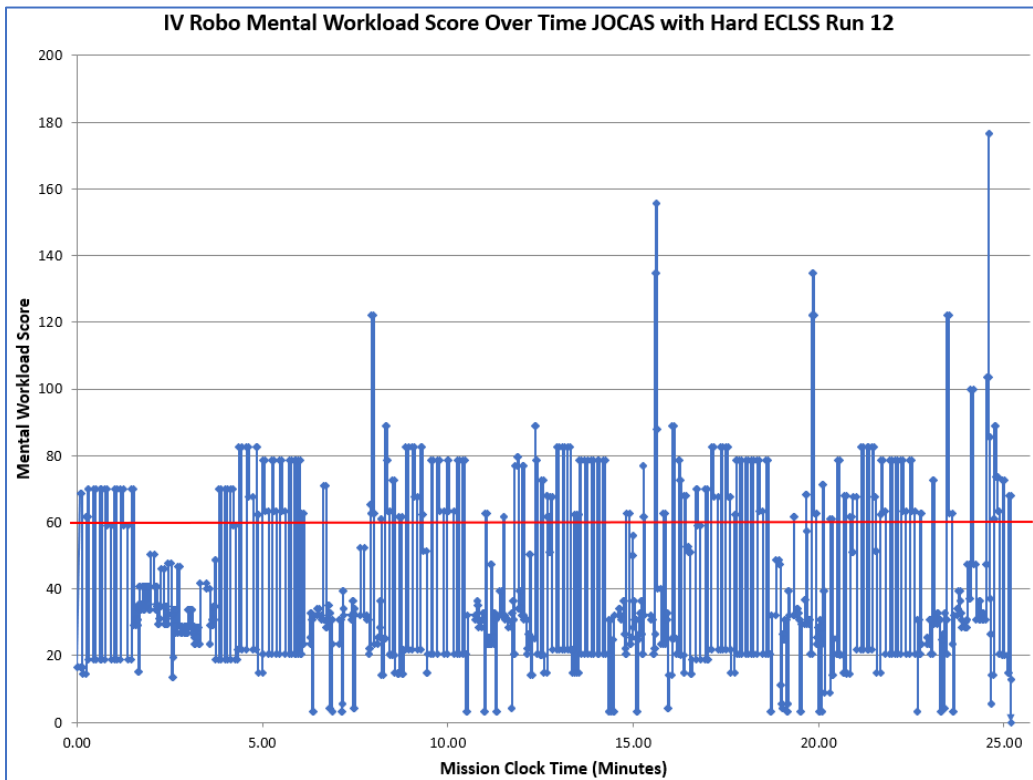
Comparison of scenarios in which an ECLSS system without failure alerting guidance, or one more difficult to monitor and operate in GCA and JOCAS modes of operation (runs 11 and 12) to the baseline GCA and JOCAS scenarios with the more advanced, and easier to monitor and operate ECLSS system (run 01 and run 02). This analysis will simulate additional task loading for the M1 robotic arm operator that may occur with a limited Mars mission crew size.

**M1 Mental Workload comparisons:**

The full workload charts, over time, for one representative mission run for each of the more difficult ECLSS system model runs are shown in Figures 95 and 96. The associated workload peaks and concurrent task instances are shown in Tables 45 and 46. In GCA and JOCAS modes of operation, the M1 robotic arm operator has significant increases in workload spikes due to the increased activity involving the ECLSS system, particularly pronounced in GCA mode.



**Figure 95. Workload Over Time for GCA with Hard ECLSS Run 11**



**Figure 96. Workload Over Time for JOCAS with Hard ECLSS Run 12**

**Table 45. Tasks Concurrently Performed at Peak Workload values Run 11**

Mission Time (Min)	Workload Score	Simultaneous Tasks
9.27	255.66	Change history graph view GCA LongComm_Listen Monitor robotic arm camera views (manual mode) Move left stick to avoid hazards/contacts Move right stick sideways (horizontal robotic arm control)
9.22	249.26	GCA LongComm_Listen Monitor ECLSS Screens (alert system off) Move left stick to avoid hazards/contacts Move right stick sideways (horizontal robotic arm control) Push button on left stick to change robotic arm speed

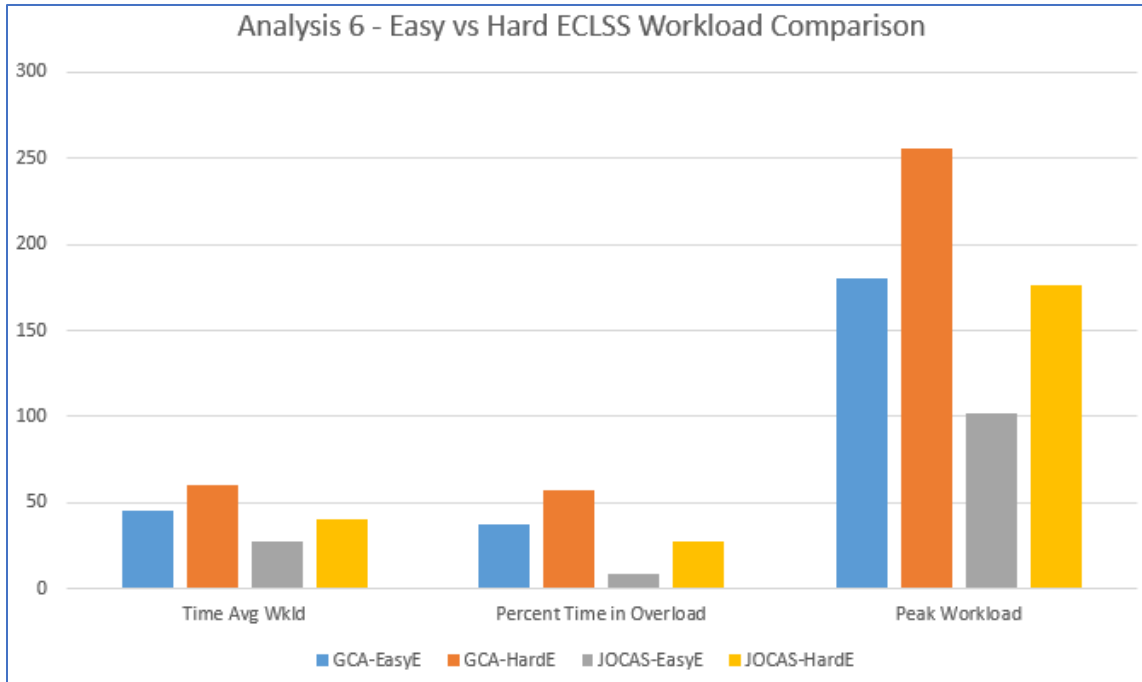
**Table 46. Tasks Concurrently Performed at Peak Workload Values Run 12**

Mission Time (Min)	Workload Score	Simultaneous Tasks
24.59	176.46	Change camera view JOCAS LongComm_Listen Monitor ECLSS Screens (alert system off) Notice poor camera views (no sys help)
15.62	155.69	Change camera view Change history graph view JOCAS LongComm_Listen Monitor robotic arm camera views (J)

Adding tasks, and task difficulty, associated with a more difficult system manage while working on the main mission increased the mental workload experienced by the M1 robotic arm operator very significantly in GCA and JOCAS modes of operations per the workload metrics shown in Table 47 and Figure 97. The time-averaged workload experienced by the M1 in GCA mode was greater than the workload threshold of 60 and they were predicted to be in overload almost 57% of the time.

**Table 47. Workload Metric Comparison Analysis 6**

Run No. – Brief Model Description	Time-Avg Workload	Percent Time in Overload	Peak Workload
01 GCA-Easy ECLSS	45.25	37.38	180.48
11 GCA-Hard ECLSS	60.51	56.94	255.66
02 JOCAS-Easy ECLSS	27.05	8.32	102.16
12 JOCAS-Hard ECLSS	39.87	27.7	176.46



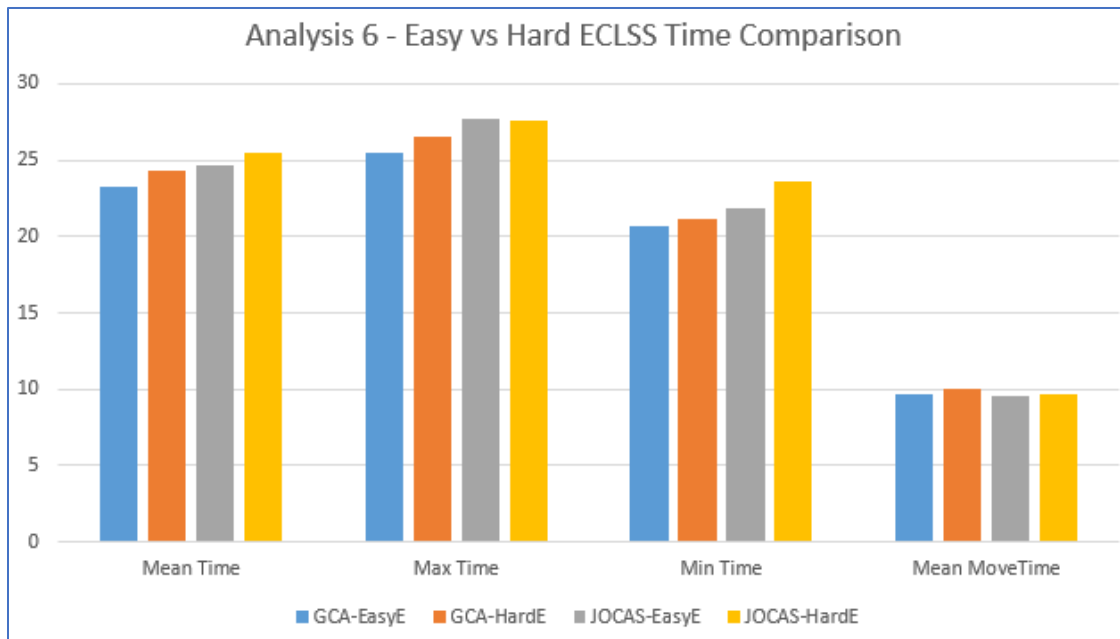
**Figure 97. Workload Metric Comparison Analysis 6**

**Mission Time Comparisons:**

Mission time metrics are summarized in Table 48 and Figure 98. Mission time metrics were not very sensitive to the manipulation of ECLSS task difficulty (i.e., when the ECLSS task required more attentive monitoring). Additional monitoring requirements would be periodic, and so the Modeled Operator may be able to monitor the ECLSS as a secondary task when time was available with little penalty.

**Table 48. Mission Time Comparison Analysis 6**

Run No. – Brief Model Description	Mean Time	Max Time	Min Time	Mean MoveTime
01 GCA-Easy ECLSS	23.2818	25.4798	20.6335	9.637
11 GCA-Hard ECLSS	24.2836	26.5375	21.2004	10.0355
02 JOCAS-Easy ECLSS	24.6516	27.6853	21.7983	9.5135
12 JOCAS-Hard ECLSS	25.4815	27.5932	23.5905	9.685



**Figure 98. Mission Time Comparison Analysis 6**

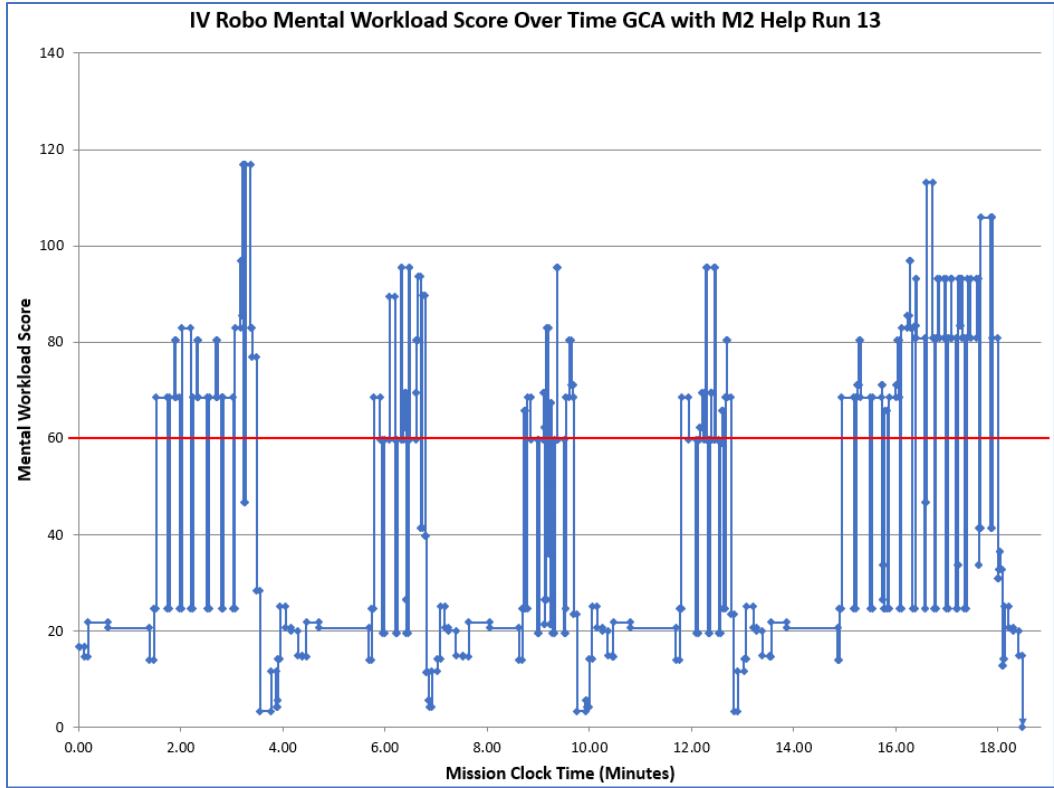
**Analysis 7:**

Comparison of scenarios in which an M2 is added to the crew, assuming that the Mars mission crew size has increased by at least one to allow this to occur, and the M2 is able to assist the M1 with EVA robotic arm control and take on extra tasking including the ECLSS monitoring in GCA and JOCAS modes (runs 13 and 14) with the baseline M1 GCA and JOCAS models (runs 01 and 02).

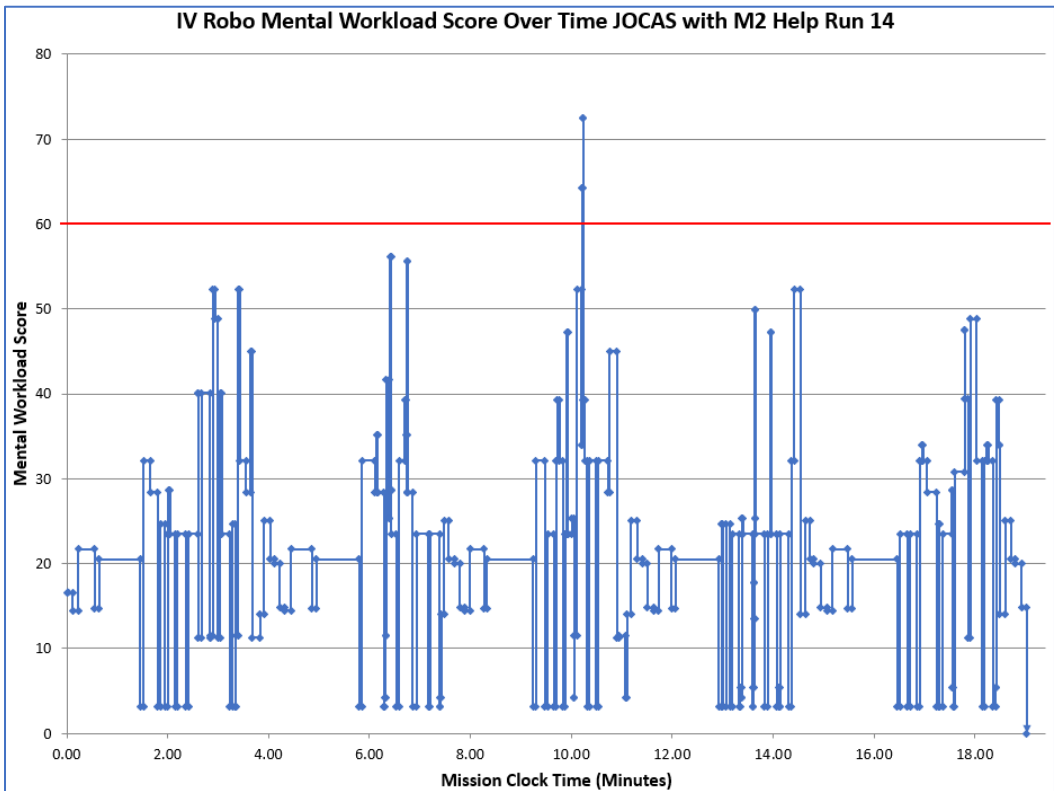
**M1 Mental Workload Comparisons:**

The full workload charts, over time, for one representative mission run for each of the added M2 models, with reduced tasking for the M1, are shown in Figures 99 and 100. The associated workload peaks and concurrent task instances are shown in Tables 49 and 50. In GCA and JOCAS modes of operation, the M1 robotic arm operator has significant decreases in workload spikes due to the assistance provided and offloading of tasks, although high workload peaks in GCA mode occur.





**Figure 99. Workload Over Time for GCA with M1 and M2 Run 13**



**Figure 100. Workload Over Time for JOCAS with M1 and M2 Run 14**

**Table 49. Tasks Concurrently Performed at Peak Workload Values Run 13**

Mission Time (Min)	Workload Score	Simultaneous Tasks
3.27	116.83	GCA LongComm_Speak Monitor positioning data Twist right stick (vertical robotic arm control)
16.61	113.15	GCA LongComm_Speak Monitor robotic arm camera views (manual mode close to end) Twist right stick (vertical robotic arm control)

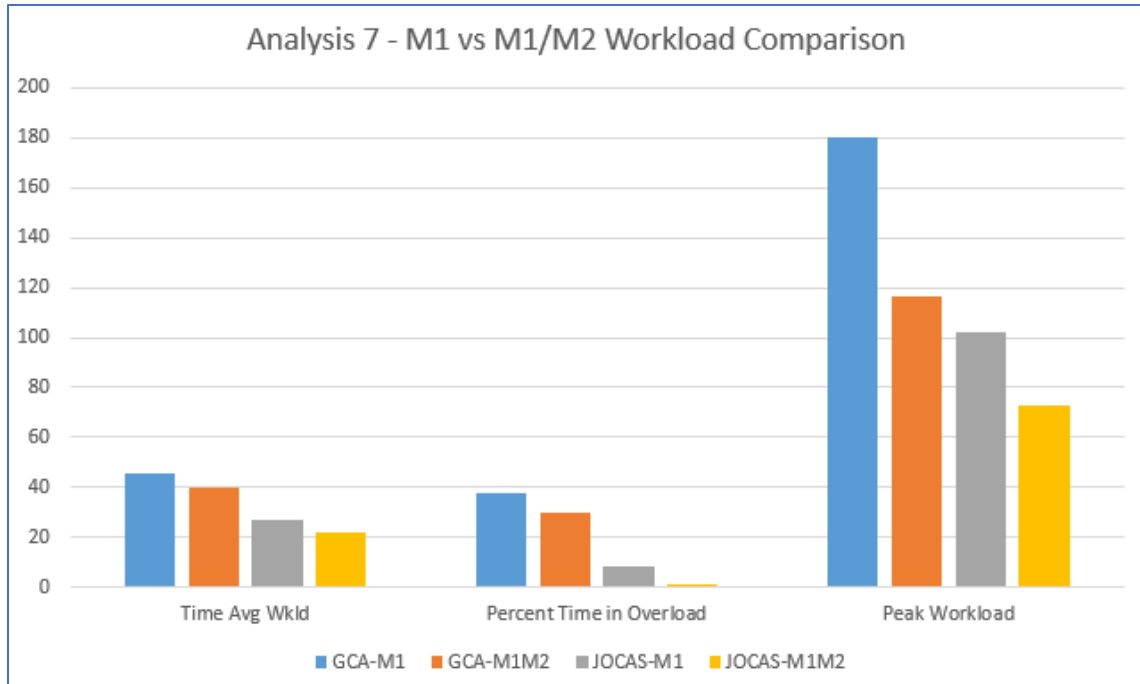
**Table 50. Tasks Concurrently Performed at Peak Workload Values Run 14**

Mission Time (Min)	Workload Score	Simultaneous Tasks
10.23	72.54	JOCAS ShortComm_Speak Monitor positioning data (J) Push button on left stick to change robotic arm speed
10.21	64.30	JOCAS ShortComm_Listen Monitor positioning data (J) Push button on left stick to change robotic arm speed

As shown in workload metric data Table 51, and Figure 101, the addition of the M2 greatly reduces time-average workload, percent time spent in overload, and peak workload experienced by the M1 operator in the GCA and JOCAS modes. In the JOCAS mode, the M1 experiences a very brief period of overload that is not far above the threshold of 60.

**Table 51. Workload Metric Comparison Analysis 7**

Run No. – Brief Model Description	Time-Avg Workload	Percent Time in Overload	Peak Workload
01 GCA-M1 Only	45.25	37.38	180.48
13 GCA-M1 and M2	39.74	29.65	116.83
02 JOCAS-M1 Only	27.05	8.32	102.16
14 JOCAS-M1 and M2	21.8	0.13	72.54



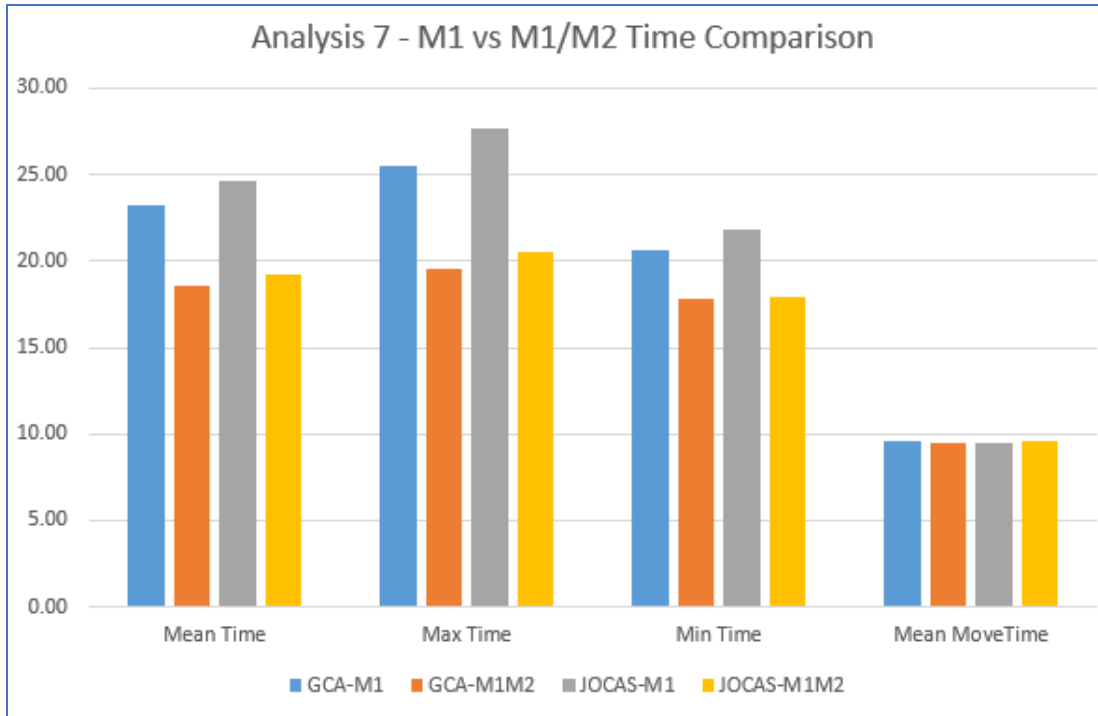
**Figure 101. Workload Metric Comparison Analysis 7**

**Mission Time Comparisons:**

Mission time metrics are summarized in Table 52 and Figure 102. Mission times were also impacted positively (reduced mission times), in GCA and JOCAS missions, by having an extra crewmember capable of being an M2. Part of this reduction was due to coordination time being reduced during pre-movement tasking, and part was due to the M2 handling an issue that occurred (was scripted during every model run) to adjust the ECLSS system.

**Table 52. Mission Time Comparison Analysis 7**

Run No. – Brief Model Description	Mean Time	Max Time	Min Time	Mean MoveTime
01 GCA-M1 Only	23.28	25.48	20.63	9.64
13 GCA-M1 and M2	18.62	19.58	17.79	9.47
02 JOCAS-M1 Only	24.65	27.69	21.80	9.51
14 JOCAS-M1 and M2	19.18	20.49	17.90	9.60



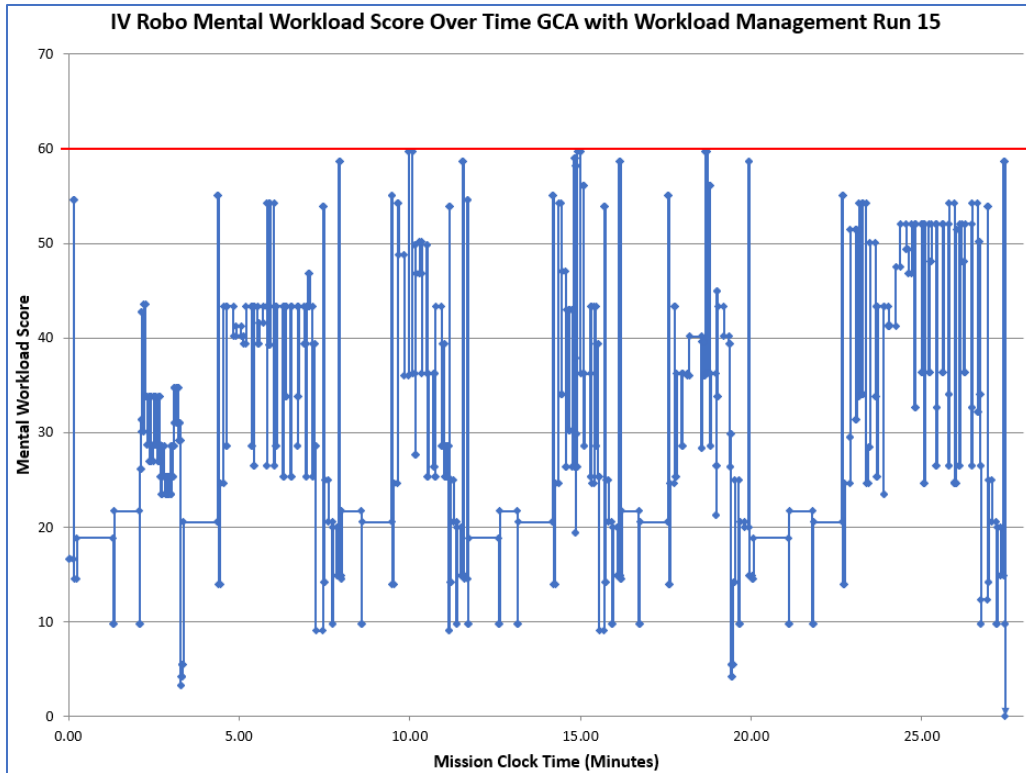
*Figure 102. Mission Time Comparison Analysis 7*

**Analysis 8:**

IMPRINT provides an analyst with the capability to run a model with workload management strategies employed. These strategies will not allow an operator to go over a threshold (usually 60), and the operator will delay tasks or drop them depending upon how they are queued up and timing of task assignments. This analysis compares the baseline GCA run (run 01) with a run with workload management strategies implements (run 15).

**M1 Mental Workload Comparisons:**

The full workload chart, over time, for one representative mission run for the GCA with workload management strategies implemented is shown in Figure 103. There are no workload peaks above the 60 threshold shown on this chart because the IMPRINT workload management strategy employed did not allow workload peaks to occur.

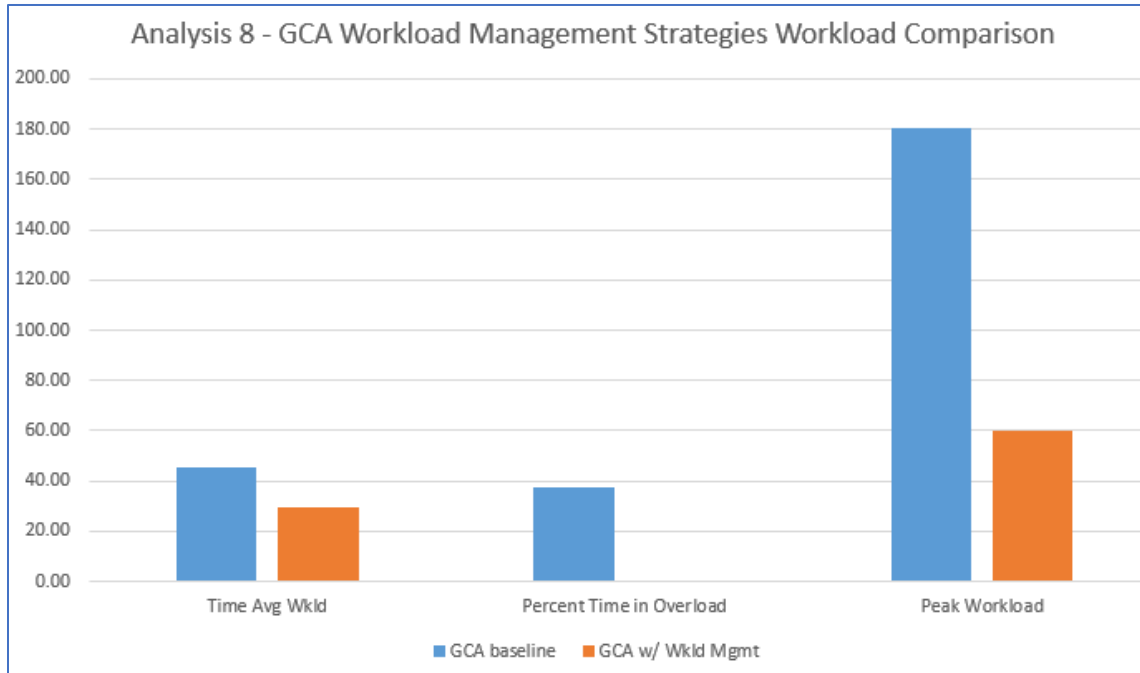


**Figure 103. Workload Over Time for GCA with Workload Management Run 15**

Per its intention, the model ran with workload management strategies employed and reduced time in overload to zero, reduced peak workload to below 60, and reduced the time-averaged workload significantly, as shown in Table 53 and Figure 104.

**Table 53. Workload Metric Comparison Analysis 8**

Run No. – Brief Model Description	Time-Avg Workload	Percent Time in Overload	Peak Workload
01 Baseline GCA	45.25	37.38	180.48
15 GCA with Wkld Mgmt	29.69	0.00	59.72



**Figure 104. Workload Metric Comparison Analysis 8**

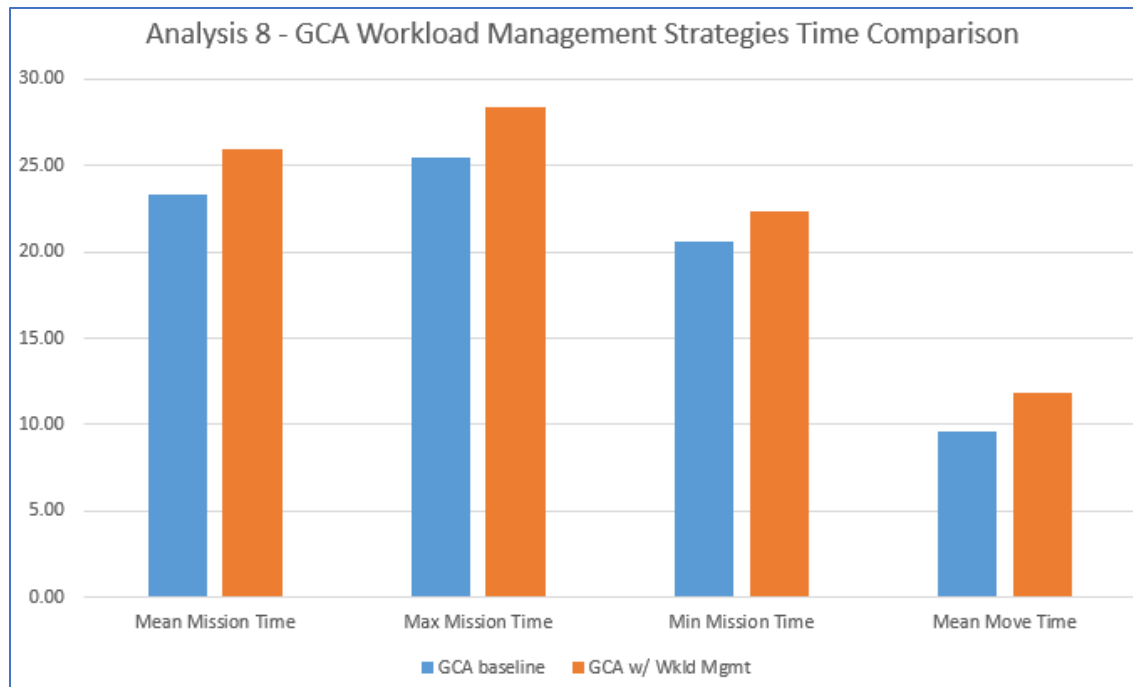
**Mission Time Comparisons:**

Mission time metrics are summarized in Table 54 and Figure 105. Mission times were increased due to the workload management strategies being employed because some tasks would be delayed until a window of low workload opportunity arose for them to be performed. Most of the mission time increases occurred during robotic arm movement, where most overload conditions occurred in the baseline model without workload management strategies employed.

The assessment team expected a greater increase in mission times due to task rescheduling. Further analysis revealed that many tasks were also dropped because they were in a queue and did not get performed as often. These tasks included communication tasks. On average, with workload management strategies employed, the M1 robotic arm operator was engaged with communications approximately 4.55 minutes per run. Without workload management strategies employed they were engaged in communications an average of 7.83 minutes per run. This is a reduction in communications of 42%.

**Table 54. Mission Time Comparison Analysis 8**

Run No. – Brief Model Description	Mean Time	Max Time	Min Time	Mean Move Time
01 Baseline GCA	23.28	25.48	20.63	9.64
15 GCA with Wkld Mgmt	25.91	28.40	22.38	11.88



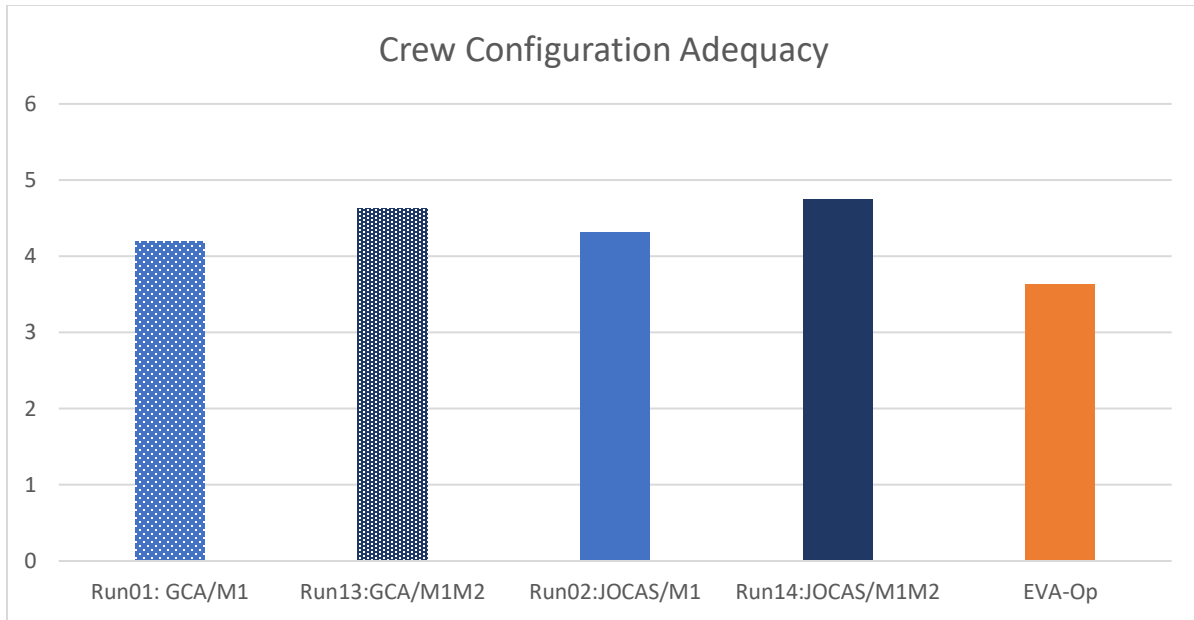
**Figure 105. Mission Time Comparison Analysis 8**

### Independent Evaluation

The trade space evaluation framework provides open-ended questions to assess the adequacy of crewing configurations. This effort assessed two main independent variables of concern with respect to reformulations of these questions to be more tailored to the scope of this effort and to permit scale responses. Five scenarios were considered, those corresponding to runs 01, 02, 13, 14 (Table 23) and a future concept that was not modeled. The future concept was described as one in which the EVA crewmember on the robotic arm has intuitive controls for the robotic arm and cameras, and where an M1 monitors the operation while also monitoring three other unrelated systems. This last case was posited by a SME from Canadarm as a possible future capability.

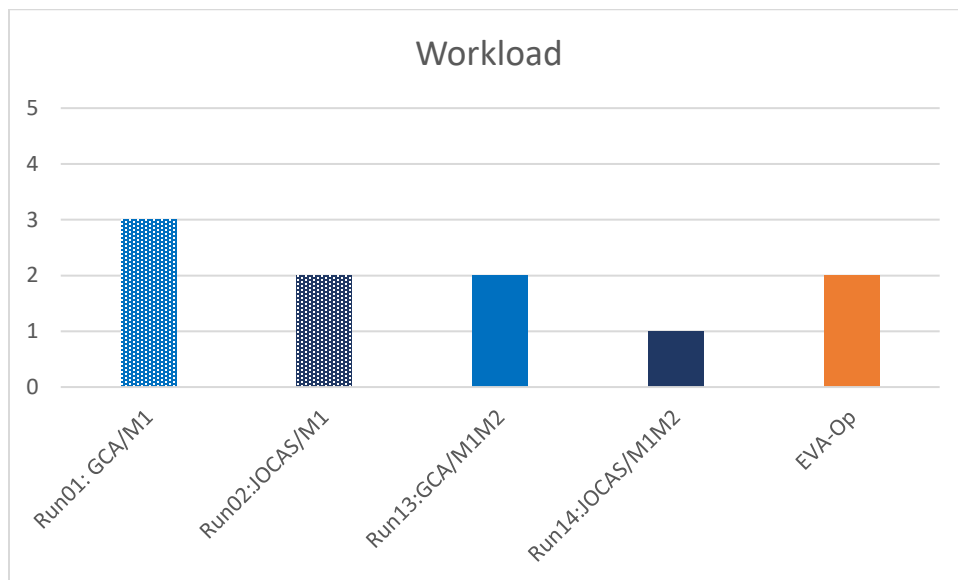
Investigators presented the survey to a crewmember who was trained to perform as M1/M2. The crewmember was encouraged to express commentary on the questions themselves and how they apply to the four scenarios; and at the conclusion of the survey, asked to comment in general on crewing (M1 versus M1 and M2), crew coordination, control modes (GCA, JOCAS) with respect to robotic assisted EVA operations. Finally, the crewmember was asked if they had any other thoughts to share. Results were provided to the crewmember for audit and to certify no changes were necessary upon reflection. None were indicated.

The trade space evaluation framework includes the major categories of: Operational Impact, Human Performance, Team Coordination, Cognitive Requirements, Organizational Constraints, Cost, and Technology Capabilities. As stated in the earlier section presenting the Trade Space Framework, we are omitting the concern of costs for these early assessments. Figure 106 shows the average scores across the five conditions.



**Figure 106. Crewing Configuration Tradespace Analysis (Scale: 1 low -6 high)**

As only one respondent's data is provided, these results are presented only as a demonstration of this parallel approach for assessing crewing configuration adequacy. This respondent's data revealed a recognition of the value an M2 provides not only to GCA operations, but also JOCAS operations – as was found in model results. However, this averaged subjective data did not reveal the modeled findings that show the ease of (nominal) JOCAS operations over GCA operations. Closer inspection of the question specifically addressing workload does reveal this correspondence (Figure 107). Workload for the GCA/M1 condition (run 01) exceeded that of the JOCAS/M1 condition (run 02), and GCA/M1 and M2 condition (run 13) exceeded the JOCAS/M1 and M2 condition (run 14).



**Figure 107. Subjective Workload Ratings (Scale: 1 low -5 high)**



The condition in which the M1 monitors the robotic arm assisted EVA while the EVA crewmember is the principal controller shows some benefit in overall crew configuration adequacy. Commentary suggested that if this technology is reliable, M1 could more effectively monitor/address other systems which would be an advantage with a small IV crew size; and EVA crew often have better situation awareness of proximity to structure and so might derive benefit from direct control of the robotic arm under nominal conditions. Interestingly though, the respondent indicated that the M1's workload in this situation may be higher for this case than for the ideal current operation (JOCAS with an assisting M2). Commentary suggested that even if the EVA crewmember is directly controlling the robotic arm, IV's concern for that crewmember would be a paramount and workload would be associated with ensuring rapid and successful intervention if necessary.

This investigation of a future concept shows value in conducting this form of evaluation even earlier in assessments as findings may provide useful information for model development. For example, were this future EVA crewmember-guided robotic arm control be modeled, initial SME interviews would specifically address the monitoring and communicating frequency and workload associated to alleviate concerns about the EVA crewmember during operations, and the impact on available resources to conduct other tasking. The IV crewmember operating the external cameras can have a better view than the EVA crewmember. This analysis also points out the need to assess the workload for all participants in the operation – here, the EVA crewmember becomes particularly important to consider. While the respondent here suggested the advantage of first-person viewing while operating the robotic arm, another crewmember (Crew Comment Database Inquiry, 2023) suggested that the EVA crewmember on the robotic arm may not be able to appropriately localize elements outside because of parallax-induced visual distortions, e.g., what might seem parallel to their body may not be. Understanding workload associated with gaining appropriate situation awareness for all participants is necessary.

## **Discussion**

### **Methodological Considerations**

Observational data, SME interviews and reviews, and system descriptions, training data and understanding of crew interfaces and automation characteristics inform model development. Observation of related operations and SME inputs are essential to appropriately characterize mental workload of constituent tasks, and to assess model outputs and provide iterative guidance to refine models. This effort was fortunate to have anticipated the iterative need for these data sources and ensured access to direct mission observation and excellent SMEs. While the data collected for this effort are based on these representative data, the number of data sources were few and therefore results are potentially biased to individual differences. Future modeling efforts will necessitate the early, and iterative access to SMEs, operational data and observational opportunities and would benefit from a broader sampling of perspectives. Observational data was collected from watching real-time flight following of a robotic arm assisted EVA and reviewing such operations in CODA and coding the audio loops associated with the mission. While these audio loops provide a textured source of data, content can be noisy and difficult to attribute to speakers' roles. Some data that would have been useful for the robotic arm assisted model were not available (i.e., video of the mission's M1 and M2 during robotic arm assisted EVA). This data would have permitted a better characterization of fluidity in roles, internal communication workload, and any errors and uncertainty mitigated by cross-checks. This effort used

IMPRINT/S-Print's characterization of human/automation interaction (including response to automation failures), fatigue and workload management features.

The robotic arm movement models constructed during the development of S-Print for NASA's HRP [ref. 45] was based on data collected during part-task simulation trials. It did not include some tasks associated with the EVA/robotic arm control mission (monitoring, communications), include more realistic movement times and segmented travel, or include procedural context of manual as GCA-to-Published and automated as JOCAS operations. These modifications resulted in higher fidelity models and demonstrated higher mental workload for the modeled robotic arm controller and longer scenario execution times. This reveals a common experience of human performance modelers; that as models develop, often unappreciated task demands are revealed, and the model predictions of task difficulty generally increase with model granularity. Often this is because tasks that are not explicitly defined, "implicit tasks," become evident, including monitoring the amount of time a procedural step might nominally take. One crewmember noted, when looking at the procedure note indicating "Expect 90 seconds," this crewmember recalled thinking "How are we going to track this? What if it takes more than 90 seconds?" (Crew Comment Database Inquiry, 2023). Consequently, this crew practiced the procedure execution to the point of knowing how to use timers to meet its intent. This is an example of the importance of the implicit tasking associated with of timekeeping. Modeled operator mental workload can also decrease with development, as staffing levels, automation capabilities, crew rest and tasking schedules are known and are increasingly supportive.

IMPRINT/S-Print also permits characterization of tasks in terms of likelihood of performance errors. The effort described here did not model human performance errors for this task because our data corpus did not reveal these. Access to more observational data, perhaps including analog and training data with the time to fully analyze these would enable such an analysis.

Additionally, future developments may benefit from consideration of errors and additional dependent measures to fully characterize the impact of automation design trades. Other metrics that might be useful include situation awareness and perceived risk. Current measures were assessed by SMEs but not formally analyzed for correspondence with perceived workload when immersed in the operational environment and tasking. For these, and the workload constructs used in the current model, it is also necessary to define correspondence between model levels and operationally relevant levels (e.g., what difference in performance execution times between two crew configurations is operationally meaningful?)

While IMPRINT/S-Print does offer several approaches to modeling fatigue as a performance shaping factor, and various methods of strategic workload management, the effort here included only a single demonstration of each. Further, there are other aspects of the ambient and constructed environment that SMEs indicated would likely mediate M1 performance. Examples of such characteristics include visibility levels/camera views and lighting conditions and robotic arm configuration/stability as they affect robotic arm control speed and mental workload; and the robotic workstation interface characteristics and usability.

As ConOps evolve to better specify training and crew roles, the characteristics of relevant technology, and performance quality requirements, models should be updated and should include data obtained from relevant human-in-the-loop and analog studies.

## Model Execution Observations

All model runs in which an M1 manually operates the robotic arm alone demonstrate excessive workload peaks, and higher percentages of time in overload conditions and time-averaged workload for the course of the scenario. Adding an M2 to assist lowers M1's workload somewhat, but it is not significantly alleviated. While M1/M2 SMEs interviewed said that training prepares crew to operate as an M1 without assistance from an M2, it is not preferred, is significantly more stressful and slower, and creates a greater potential for risk. A comment from an early Expedition in the Crew Comments Database noted that it was difficult to manage the robotic arm, performing as the M1, and manage the rest of the vehicle. *“(It seemed that the) IV crew must be at three places at once. This is especially challenging when a system failure occurs.”*

**F-8.** IMPRINT/S-PRINT modeling results predict that two crew (i.e., an M1 and an M2) will be necessary to mitigate unacceptably high workload of an M1 operating the robotic arm manually (GCA).

**F-9.** IMPRINT/S-PRINT modeling results predict that an M1 using automated (JOCAS) operations without M2 assistance to control the arm will experience high workload given the task complexity and technology characteristics.

JOCAS controlled runs show workload reduced for M1 (all other factors held constant). Still, all runs wherein M1 operates the robotic arm alone using JOCAS show peak workloads over threshold and high time-averaged workload – albeit significantly lower time in overload, unless attending to the more engaging ECLSS task. Only when the M1 is assisted by an M2 operator does their peak workload fall below threshold. When so assisted, M1's time-averaged workload and mean execution time is the least of all JOCAS-controlled conditions and they have essentially no significant amount of time in an overloaded state.

When failures occur in automated control (JOCAS) when M1 works alone, this operator's workload is demonstrably higher than in unfailed conditions, and all of these are over threshold. When failures occur, nominally reversion to manual operations takes place and there is a tax to the execution time of subsequent tasks, as operators shift contexts to the interrupting recovery tasks. If we consider the automation to perform these recovery tasks, and therefore impose no time penalty, execution time for the run is shortened and M1's time-averaged workload for failure runs is minimized.

Increasing the salience of failure alerts, and ensuring operators are appropriately tuned to anticipate such failures act to reduce workload. This underscores the importance of communicative, transparent technology and ensuring crew have appropriately calibrated trust for the technology they must use.

**F-10.** IMPRINT/S-PRINT modeling results predict that increasing the salience of failure alerts and ensuring operators have appropriately calibrated trust in automation reduces workload when automated robotic arm control automation fails.

Model execution also permitted consideration of the benefits of crew rest and workload-protective scheduling practices. When robotic arm operations are particularly challenging (e.g., when conducting manual operations, fatigued M1 experienced higher workload peaks, time-averaged workload, and percent time in workload, and took longer to perform all the required tasks).

**F-11.** IMPRINT/S-PRINT modeling results predict that sleep debt increases the M1's workload measures and lengthens performance times.

IMPRINT/S-PRINT permits modeling various workload management strategies. This effort exercised one in which the modeled operator (M1) could manage their workload to never experience high workload (over threshold). Doing this results in differing tasks, some of which are ultimately shed entirely, and extending total execution time. Depending on the tasks shed, this could have significant mission-level impact. For instance, monitoring and communication tasks support crew Situation Awareness (SA) and failure to execute these can result in misunderstandings of system modes, and disconnects among crewmembers. Ensuring peak workload remains below threshold, trades with extending total execution time.

Analyses of model results provide insight into the Crew Size appropriate for a Mars transit vehicle robotic arm assisted EVA when unassisted by Earth MCC, and the forms of technology that are supportive of this operation. Based on current assumptions and data, M1 operating the robotic arm alone benefits from robotic arm technology that does not require manual controls, has salient indicators for failures, and for which they have an accurate mental model for expected reliability. Having an M2 protects against unacceptable workload when a failure occurs, when manual control is necessary and when the M1 operator is fatigued.

### **7.2.3.5 Conclusions**

Robotic arm capabilities and characteristics modeled here were based on existing ISS SSRMS modes to contrast manual and automated control, and with notional variants characterizing operator reliance on automation, alert salience, and the capability for automated recovery actions when automated control failed. While this model does not purport to replicate any particular future Moon-to-Mars robotic arm operational scenario, the context in which the modeled scenario occurs is consistent with that envisioned in the HRP HSIA Evidence report, and the operational context described in the Moon-to-Mars Architectural Definition workshop [ref 11].

Future models of this task should consider expanding upon the scope of tasks that IV crewmembers perform in support of robotic arm assisted EVA operations. These include the cognitively demanding tasks associated with trajectory planning and diagnostics currently performed by ground support; further considering the impact of lighting and robotic arm physical stability as constraints on robotic arm movement; and consider implementing design details of future robotic arm, camera and clearance prediction/alerting technologies as they are developed for the Moon-to-Mars missions. Finally, results from the Independent Evaluation highlight the need to model the experiences of all crewmembers involved in an operation to fully understand workload impacts of a crew configuration.

This HARI modeling effort demonstrates that crew size (M1 alone, M1 with M2), control mode (manual/GCA versus automated/JOCAS), sleep debt and workload management strategy impact the modeled operator's workload and in some cases execution times. Further, automation failures

highlight the benefit of the alerting for the modeled operator (M1) workload and the negative consequences of over-trusting automation when failures do occur. As such, the IMPRINT/S-PRINT modeling approach exemplifies an appropriate approach to consider operator workload and performance time impacts with respect to crew number, technology and human/machine interface capabilities, and operator performance factors (fatigue and workload management strategies). Results from this modeling approach, demonstrating the impact of technology capabilities and characteristics (e.g., form and level of automation, alert salience, trustedness) on operator workload and ultimately crew size, also inform what technologies are invested in to meet mission requirements and other ConOps decisions (e.g., crew roles and task allocations, crew rest scheduling).

#### **7.2.4 Mars Transit Crew Model**

##### **MARS TRANSIT OPERATIONS SCENARIO**

*On the transit to Mars, the crew is engaged in meaningful work that includes tasks performed by ISS crew on earlier LEO missions and additional tasks that had been performed real-time by flight controllers during the ISS Program. While time-delayed MCC support is assumed to be continually available, the shift in tasking from the ground to the crew was necessary given the long communication delay between Earth and Mars and the need for certain tasks to be performed real-time. The crew schedule allows the Mars crew time to perform all their duties and accommodates schedule changes in the event of a medical condition experienced by one crewmember without overloading the remaining crewmembers. The ability of the crew to complete all assigned duties during the transit to Mars was considered in the development of the Mars Transit Crew model.*

##### **7.2.4.1 Purpose and Scope**

The other IMPRINT human performance models associated with this assessment focused on specific systems and scenarios of interest, procedures, and tasks performed by Mars crewmembers, and the detailed mental workload experienced by crewmembers associated with those scenarios. Those models were built utilizing the IMPRINT Operations model. The Mars Transit Crew model utilized the IMPRINT Force model to perform a higher-level analysis associated with crew utilization and manpower requirements given the impact of unplanned, or different anticipated tasking, on a crew's ability to perform work during a 9-month Mars transit mission.

##### **7.2.4.2 Methods and Procedures**

To build a Mars Transit Crew model, the assessment team worked with a flight director and a payloads operations director to develop a list of Mars mission assumptions of the types of tasks that likely would remain with MCC and those tasks that would likely shift to the crew (e.g., MCC is prime for nominal commanding, crew is prime for commanding that requires real-time verification). Based on this set of assumptions, the team conducted structured interviews of flight controllers to document tasks for each vehicle system or operation that would likely be shifted from MCC to the Mars crew.

Planned tasks shifted to the crew included daily health and status check on IT equipment, safing for maintenance tasks (e.g., powering down equipment prior to performing maintenance), tasks associated with daily operations, and training to ensure the crew would be able to retain Mars

lead qualifications throughout their mission (see Section 7.2.5). While the assessment team recognizes some of these tasks may be candidates to automate, the team chose to include all tasks currently performed by humans and not currently anticipated to be automated in this initial build of the Mars Transit Crew model.

Unplanned tasks included vehicle maintenance, medical events, responding to vehicle system emergency, warning, caution, and advisory events, and responding to a major incident or unforeseen failure. The assessment team gathered relevant source data for each category of unplanned tasks and analyzed the data sets with applicable and adequate statistical methods and techniques to predict the rate of the event occurrences during a 9-month transit to Mars and the effect on crewmembers' work time associated for each occurrence of an event. Given the uncertainties in the source data, the assessment team considered IMPRINT results with average values of all task categories and results with 75% confidence of all categories to represent a conservative bound on the average, and then 95% confidence of all categories to represent an upper bound of all of the estimates.

The assessment team built two predictive models of Mars transit scenarios, using Mars-unique planned and unplanned tasks occurring at the average and 75% confidence levels. The two Mars-unique models were used to conduct a comparative analysis of IMPRINT Force model results with a model of tasks performed on the ISS.

### *Crew Schedules*

At the base of the IMPRINT Mars Transit Crew model were the anticipated regular schedules that each crewmember was assigned listing planned activities with durations. Using the MAT generated Composition of the Nominal Work Week (Mars Surface) (Figure 108), the assessment team built a Composition of the Nominal Work Week (Mars Transit) (Figure 109).

<b>Composition of the Nominal Work Week (Mars Surface)</b>				
<i>Per SSP 50261-02, Rev. D-SSCD 16104, ISS Generic Groundrules and Constraints, Part 2: Execute Planning,</i>				
	Template A: Work Sol Type 1	Template B: Work Sol Type 2	Template C: Weekend / Rest Sol 1	Template D: Weekend / Rest Sol 2
No. of days per 7-sol Week	4	1	1	1
Available Work Hours	6:30	6:30	1:00*	
Daily Planning Conference (DPC)	0:30 - 0:50	0:30 - 0:50	N/A	0:15 - 0:25
Morning Prep-Work**	0:20 - 0:30	0:20 - 0:30	N/A	N/A
Evening Prep-Work ** ***	0:50 - 1:00	0:30	N/A	0:50 - 1:00
Midday Meal	1:00	1:00	1:00	1:00
Exercise	2:30	2:30	2:30	2:30
Sleep	8:30	8:30	8:30	8:30
Post-Sleep	1:30	1:30	1:30	1:30
Pre-Sleep	2:00	2:00	2:00	2:00
Housekeeping	N/A	N/A	3:00	N/A
Weekly Planning Conference (WPC)	N/A	N/A	0:40	N/A
Private Medical Conference (PMC)	0:15	N/A	N/A	N/A
Private Family Conference (PFC)	N/A	N/A	N/A	0:15

\* May be split between both Weekend/Rest Sols

\*\* May be reduced to accommodate activities that do not count against the crew's available work hours

\*\*\* May be reduced from 1:00 to 0:30 if the following sol is a Weekend/Rest Sol

***Figure 108. MAT Composition of the Nominal Work Week (Mars Surface)***

<b>Composition of the Nominal Work Week (Mars Transit)</b>					
<i>Per SSP 50261-02, Rev. D-SSCD 16104, ISS Generic Groundrules and Constraints, Part 2: Execute Planning, Table 3.1.5-1,</i>					
	Template A: Work Mon.-Wed. w/o PMC	Template A: Work Thurs. w/PMC	Template B: Work Fri.	Template C: Weekend / Rest Sat.	Template D: Weekend / Rest Sun.
<b>No. of days per 7-day Week</b>	3	1	1	1	1
<b>Available Work Hours*</b>	6:30	6:30	6:30	1:00*	N/A
<b>Daily Planning Conference (DPC)</b>	0:30 - 0:50	0:30 - 0:50	0:30 - 0:50	N/A	0:15 - 0:25
<b>Morning Prep-Work**</b>	0:20 - 0:30	0:20 - 0:30	0:20 - 0:30	N/A	N/A
<b>Evening Prep-Work ** ***</b>	0:50 - 1:00	(0:45) 0:50 - 1:00	0:30	N/A	0:50 - 1:00
<b>Midday Meal</b>	1:00	1:00	1:00	1:00	1:00
<b>Exercise</b>	2:30	2:30	2:30	2:30	2:30
<b>Sleep</b>	8:30	8:30	8:30	8:30	8:30
<b>Post-Sleep</b>	1:30	1:30	1:30	1:30	1:30
<b>Pre-Sleep</b>	2:00	2:00	2:00	2:00	2:00
<b>Housekeeping</b>	N/A	N/A	N/A	3:00	N/A
<b>Weekly Planning Conference (WPC)*</b>	N/A	N/A	N/A	0:30	N/A
<b>Private Medical Conference (PMC)</b>	N/A	0:15	N/A	N/A	N/A
<b>Private Family Conference (PFC)</b>	N/A	N/A	N/A	N/A	0:15
<b>FD/CREW-CONF****</b>			0:30		
<b>Off Duty</b>				4:00	7:00

\* May be split between both Sat. and Sun. Transit has is on Sat.

\*\* May be reduced to accommodate activities that do not count against the crew's available work hours

\*\*\* May be reduced from 1:00 to 0:30 if the following day is a Weekend

\*\*\*\* GGRC has 20 min. Fri. FD/CREW-CONF and has a 30 min. Sat WPC. Transit has each for 30 min. (0.50 hrs).

**Figure 109. NESC Composition of the Nominal Work Week (Mars Transit)**

The Composition of the Nominal Work Week is not a schedule but a listing of crew-assigned tasks and associated task durations. To model in IMPRINT, the assessment team built 7-day repeating schedules that contained all planned activities associated with the Mars transit scenario for a four-person crew. Figure 110 shows 1 day of the 7-day repeating schedules.



Thursday w/PMC				
	Crew 1	Crew 2 (IT)	Crew 3	Crew 4
12 AM	Sleep 6 hr.	Sleep 6 hr.	Sleep 6 hr.	Sleep 6 hr.
1 AM				
1 AM				
3 AM				
4 AM				
5 AM				
6 AM	Postsleep 1.5 hr.	Postsleep 1.5 hr.	Postsleep 1.5 hr.	Postsleep 1.5 hr.
7 AM	DPC	DPC	DPC	DPC
8 AM	Exercise 2.5 hr	morn PFW	morn PFW	morn PFW
9 AM		Ops Lan Work 1.0 hr	Work Hours 3.5 hr	Work Hours 4.0 hr.
10 AM		Work Hours 1.0 hr		
11 AM	morn PFW	Exercise 2.5 hr	Midday Meal 1 hr	Midday Meal 1 hr
12 PM	Work Hours 1.5 hr.			
1 PM	Midday Meal 1 hr	Midday Meal 1 hr	Work Hours 1 hr.	Work Hours 2.25 hr.
2 PM	(start 1:45 pm, ends 6:45 pm) Work Hours 5.0 hr	Work Hours 4.50 hr	Exercise 2.5 hr	even. PFW .75 hr
3 PM				
4 PM			PMC .25 hr	(start 4:45 pm) Exercise 2.5 hr (end 7:15 pm)
5 PM			(start 4:45 pm) Work Hours 1.75 hr	
6 PM			PMC .25 hr @ 6:30	
7 PM	even. PFW @ 6:45 pm 0.75 hr.	even. PFW @ 6:45 pm 0.75 hr.	even. PFW @ 6:45 pm 0.75 hr.	PMC .25 hr
8 PM	Presleep 2 hr	Presleep 2 hr	Presleep 2 hr	Presleep 2 hr
9 PM	Sleep 2.5 hr	Sleep 2.5 hr	Sleep 2.5 hr	Sleep 2.5 hr
10 PM				
11 PM				

**Figure 110. Thursday Schedule for Four Crew**

These 7-day repeating schedules contained all planned activities associated with the Mars transit scenario and were largely based on similar ISS missions. Examples of planned activities included sleep, work hours, exercise, and housekeeping. Each of the four crewmembers was placed on a

7-day repeating schedule, each one unique as partially necessitated by the decision to stagger exercise times.

An IMPRINT model executed with the regular schedules and planned events, and no modifications to the schedule associated with the Mars transit scenario, or unplanned events associated with ISS and/or the Mars scenario, was considered to be “Perfect ISS World Baseline” for the purposes of the Mars transit analyses. An example snippet of a regular schedule for one crewmember for Day 5 (Day 5 starts with four full days elapsed, denoted in the time format 4 00:00 in the table) and Day 6 (Friday and Saturday, the schedule starts on Monday) is shown in Figure 111.

Activity	Start Time	End Time	Total Activity Time
Sleep	4 00:00	4 06:00	06:00
Postsleep	4 06:00	4 07:30	01:30
DPC	4 07:30	4 08:00	00:30
Exercise	4 08:00	4 10:30	02:30
Morning PFW	4 10:30	4 11:00	00:30
Work Hours	4 11:00	4 12:30	01:30
Midday Meal	4 12:30	4 13:30	01:00
Work Hours	4 13:30	4 18:30	05:00
Evening PFW	4 18:30	4 19:00	00:30
FD Crew Conference	4 19:00	4 19:30	00:30
Presleep	4 19:30	4 21:30	02:00
Sleep	4 21:30	5 00:00	02:30
Sleep	5 00:00	5 06:00	06:00
Postsleep	5 06:00	5 07:30	01:30
WPC	5 07:30	5 08:00	00:30
Exercise	5 08:00	5 10:30	02:30
House Keeping	5 10:30	5 12:30	02:00
Midday Meal	5 12:30	5 13:30	01:00
House Keeping	5 13:30	5 14:30	01:00
Work Hours	5 14:30	5 15:00	00:30
Safing	5 15:00	5 15:30	00:30
Off Duty	5 15:30	5 19:30	04:00
Presleep	5 19:30	5 21:30	02:00
Sleep	5 21:30	6 00:00	02:30

**Figure 111. Example Snippet of a Regular Mars Transit Crew Schedule**

Other inputs to the Mars Transit Crew model included adjustments to crewmember schedules associated with work they would need to perform during a Mars transit due to delayed communication with the MCC, and anticipated unplanned events that could occur based on ISS historical data. Some of these unplanned events were also applicable to the Perfect World ISS Baseline. These were used to create an adjusted baseline model for comparative purposes, an ISS scenario model with anticipated unplanned events that impact the crew, or the “Adjusted ISS Scenario.”

The addition of Mars scenario-specific tasking and unplanned events that would need to be addressed by the in-transit crew, as opposed to the ground in the ISS mission environment, allowed for the exploration of the impacts on these events on a Mars crew’s ability to perform work during the transit scenario. Data input into the model was either adjusted planned schedules (e.g., one crewmember was assigned to perform Operations Local Area Network (Ops LAN) IT work in their regular schedule in place of normal work hours) or unplanned events in IMPRINT. Post-processing was performed for other tasking (e.g., dealing with anticipated maintenance

events and task management). The rest of this section details how data was derived, and how it was input into the IMPRINT Force model.

### *Model Data*

For the Mars Transit Crew model, several data sets are considered for IMPRINT Force modeling to predict Mars mission planned and unplanned crew task performance impacts. The data sets considered are:

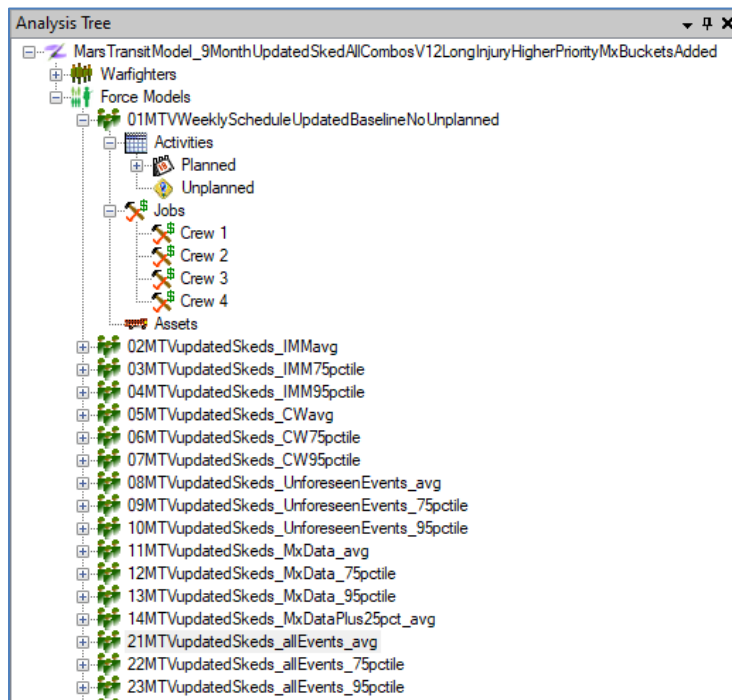
- Integrated Medical Model (IMM) Data
  - Crew medical conditions and illness frequency and crewmember time-off due to illness (see Section 7.2.4.2.1).
- Emergency, Caution, and Warning (ECW) Data
  - Vehicle system ECW events that need crew's attention and actions (see Section 7.2.4.2.2).
- Advisory Data
  - Vehicle system advisories that need crew's attention and possible actions (see Section 7.2.4.2.3).
- Vehicle Maintenance Data
  - Scheduled and unscheduled vehicle maintenance tasks (see Section 7.2.4.2.4).
- Major Incident/Unforeseen Event Data
  - Major vehicle incident and unforeseen events (see Section 7.2.4.2.5).
- MCC Task Data
  - MCC real-time tasks shifted to the crew given the communication delay for missions to Mars (see Section 7.2.4.2.6). Task shifting due to a communication blackout was not considered in the analysis of this model.

The basic approach for the first five data set categories was to gather relevant and applicable source data for each category, analyze the data set with applicable and adequate statistical methods and techniques to predict the rate of the event occurrences during 9 months of Mars transit and the affected crewmembers' time off or tasking time for each event occurrence. The frequency and crew time-off data were put into time buckets which are a set of discrete time-off intervals (e.g., 0 to 8 hours, 8 to 48 hours for the medical event attribute, etc.). Time buckets were established with some analytical rationales respectively for each attribute data set. The rationale of using time buckets was to simplify the analysis as an initial effort of the Mars Transit Crew model.

With the nature of the original data sets built for each data category, it is possible to refine the analysis with a continuous scale of time-off for producing full probabilistic results. However, as the current approach is not probabilistic, the event frequency and time-off are predicted at average (~50%), 75%, and 95% confidence levels for each attribute to cover data and modeling uncertainty. The system uncertainty analysis result was obtained through aggregating individual attribute uncertainty by running IMPRINT Force model with attributes at average and 75% confidence levels. IMPRINT results with 95% confidence level of all attributes represents approximately the worst case of the combined effect of all attributes. This was considered by SMEs to be unrealistic, so while these calculations are shown, the results were not included in the findings in this report.

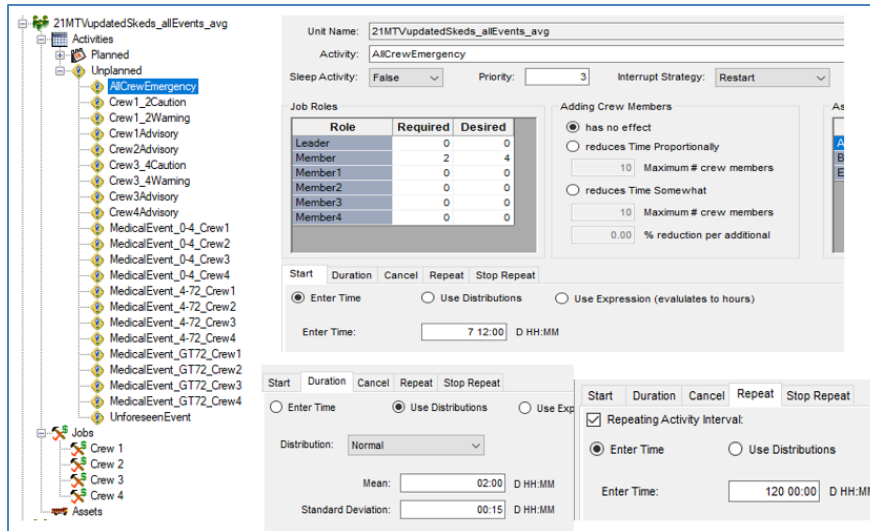
With the detailed uncertainty analysis results and associated probabilistic distributions available, an IMPRINT Force model refinement is possible that takes individual results with probabilistic distributions as input to Force model and run system level probabilistic analysis to derive system 50%, 75%, and 95% confidence level values for event frequencies and affected crew time-off. By considering the individual attributes, rather than where all attributes at each confidence level were combined, including the 95% confidence level for may prove useful.

For the IMPRINT model, individualized models were created for the Perfect ISS World Baseline scenario, without any unplanned events or Mars mission changes, for each unplanned activity individually at the different potential occurrence levels, and for combined Mars transit scenarios with each unplanned event forecasted and distributed to occur within their different buckets. All these models were created within one IMPRINT “Analysis”, which is one IMPRINT file and a collection of models. This approach allowed the assessment team to copy parts of modeled scenarios (e.g., different levels of anticipated unplanned events) into other scenarios. The analysis tree showing different IMPRINT Force models developed is shown in Figure 112. The top Force model shown, with the tree expanded, is the Perfect ISS World Baseline model without additional tasking or unplanned events. The bottom three Force models shown are fully assembled models with unplanned events identified.



**Figure 112. IMPRINT Analysis Tree Showing Different Force Models**

Unplanned events were scripted to occur according to the data collected and analyzed per the following subsections. For events that were predicted to occur more than once, they were made to be repeating with intervals calculated so they would occur the correct number of times during the 9-month scenario. A master spreadsheet of unplanned events assisted the assessment team in ensuring events were ‘peanut buttered’ or spread throughout the scenario without significant overlap so individual crewmembers would not be overburdened. Figure 113 shows examples of interfaces used in IMPRINT to script unplanned events.



**Figure 113. IMPRINT Unplanned Event Interfaces**

Job roles were used to ensure different crewmembers responded to different events. In the example shown, all four crewmembers were requested (i.e., the “Desired” column in the “Job Roles” table in Figure 113) to respond to an emergency event. However, for this particular event, fewer crewmembers were “Required” to respond to the event, which allowed the response to happen if a crewmember was incapacitated due to a major injury. The other fields shown in the figure are the start time for the first occurrence of the event (i.e., 7 days, 12 hours into the scenario), the duration of the event (i.e., 2 hours with a normal distribution), and the repeat interval of the event (i.e., 120 days, or three occurrences in the 270-day scenario). For some events, the “Cancel” field was used to ensure they took place after a certain amount of time if a higher priority event made crewmembers not available to respond at the scheduled time (e.g., the planned activity of sleep was made to be a higher priority than responding to advisories). As some advisories could occur while the entire crew was sleeping, a cancel time was added to those events so they would be handled when a crewmember was available.

The Assumptions and Model Limitations subsection of this report (Section 7.2.4.3) contains details on how events were scheduled and how task post processing was performed. The Results and Discussion subsection (Section 7.2.4.4) contains details on comparative analyses performed with different unplanned events and Mars mission-specific crew tasking considered.

### 7.2.4.2.1 IMM Data Analysis and Results

#### 7.2.4.2.1.1 IMM Data Sources

Sources of the crew medical event data were provided by the IMM Project Team with the following files:

- 1). D-20221216-454 Report, December 20, 2022
- 2). S-20220624-447, NESC Assessment, August 18, 2022
- 3) SR\_447\_Fully\_Treated\_Condition\_Summary\_stats.xlsx

The IMM data primarily consist of 100 medical conditions with descriptions, and statistics of each condition with best case and worse case for event rates derived by IMM team through a set of Monte Carlo Simulation (MCS) Runs (100,000 runs), minimal, maximal, average, and standard deviation of crew time off due to the illness. IMM data were provided for the case of a crew size of four (Crew 4) and the case for a crew size of 12 (Crew 12). Table 55 provides the

list of the 100 medical conditions, and Table 56 provides the list of the statistics for each of medical conditions with sample statistics values.

**Table 55. 100 Medical Conditions in IMM**

Data_Order	Category	Medical Condition Description	Data_Order	Category	Medical Condition Description		
1	ENVIRONMENTAL	Acute Radiation Syndrome	38	Medical Illness	Abdominal Wall Hernia	70	Hearing Loss
2		Altitude Sickness	39		Abnormal Uterine Bleeding	71	Hemorrhoids
3		Barotrauma (ear/sinus block)	40		Acute Angle-Closure Glaucoma	72	Herpes Zoster Reactivation (shingles)
4		Burns secondary to Fire	41		Acute Arthritis	73	Hypertension
5		Decompression Sickness Secondary to EVA	42		Acute Cholecystitis/Biliary Colic	74	Indigestion
6		Eye Chemical Burn	43		Acute Diverticulitis	75	Influenza
7		Headache (CO2 induced)	44		Acute Pancreatitis	76	Insomnia (space adaptation)
8		Smoke Inhalation	45		Acute Prostatitis	77	Medication Overdose/Adverse Reaction
9		Toxic Exposure: Ammonia	46		Acute Sinusitis	78	Mouth Ulcer
10		Abdominal Injury	47		Allergic Reaction (mild to moderate)	79	Nasal Congestion (space adaptation)
11	INJURY/TRAUMA	Acute Compartment Syndrome	48	Anaphylaxis	80	Nephrolithiasis	
12		Ankle Sprain/Strain	49	Angina/Myocardial Infarction	81	Nose bleed (space adaptation)	
13		Back Sprain/Strain	50	Anxiety	82	Otitis Externa	
14		Chest Injury	51	Appendicitis	83	Otitis Media	
15		Dental: Avulsion (tooth loss)	52	Atrial Fibrillation/Atrial Flutter	84	Pharyngitis	
16		Elbow Dislocation	53	Back Pain (space adaptation)	85	Respiratory Infection	
17		Elbow Sprain/Strain	54	Behavioral Emergency	86	Retinal Detachment	
18		Eye Irritation/Abrasion	55	Cardiogenic Shock Secondary to Myocardial infarction	87	Seizures	
19		Eye Penetration (foreign body)	56	Choking/Obstructed Airway	88	Sepsis	
20		Finger Dislocation	57	Constipation (space adaptation)	89	Skin Infection	
21		Fingernail Delamination Secondary to EVA	58	Dental: Exposed Pulp	90	Skin Rash	
22		Head Injury	59	Dental: Caries	91	Sleep Disorder	
23		Hip Sprain/Strain	60	Dental: Abscess	92	Small Bowel Obstruction	
24		Hip/Proximal Femur Fracture	61	Dental: Crown Loss	93	Space Motion Sickness (space adaptation)	
25		Knee Sprain/Strain	62	Dental: Filling Loss	94	Stroke (Cerebrovascular Accident)	
26		Lower Extremity Stress Fracture	63	Depression	95	Sudden Cardiac Arrest	
27		Lumbar Spine Fracture	64	Diarrhea	96	Urinary Incontinence (space adaptation)	
28		Neck Sprain/Strain	65	Eye Corneal Ulcer	97	Urinary Retention (space adaptation)	
29		Neurogenic Shock	66	Eye Infection	98	Urinary Tract Infection	
30		Paresthesias Secondary to EVA	67	Gastroenteritis	99	Vaginal Yeast Infection	
31		Shoulder Dislocation	68	Headache (Late)	100	Visual Impairment and Increased Intracranial Pressure (VIIP) (space adaptation)	
32		Shoulder Sprain/Strain	69	Headache (space adaptation)			
33		Skin Abrasion					
34		Skin Laceration					
35		Traumatic Hypovolemic Shock					
36		Wrist Fracture Wrist					
37		Sprain/Strain					

**Table 56. IMM Event Statistics List with Sample Data Values\***

Scenario	Events	Events_Mean_trial	Event_Minimum	Event_Maximum	Event_SD	TXQTL_Mean_trial	Minimum_TXQTL	Maximum_TXQTL	TXQTL_SD
0	36	0.00036	0	1	0.0190	13.2288	1.5063	23.9585	5.3820
1	12	0.00012	0	1	0.0110	2766.3399	257.6265	5852.7661	2040.1925
0	98	0.00098	0	1	0.0313	159.4366	2.0567	516.5625	119.1092
1	14	0.00014	0	1	0.0118	3459.0742	10.9270	6176.5806	2202.9082
0	7438	0.07438	0	4	0.2729	15.6408	0.1588	31.8920	6.3078
1	176	0.00176	0	2	0.0422	289.5031	7.5903	860.1307	200.9336
0	15	0.00015	0	1	0.0122	1665.3057	1.7338	5571.8837	1991.4857
1	5	0.00005	0	1	0.0071	3586.3611	130.4813	5776.9732	2434.1991

\*SD – Standard Deviation

TXQTL – Quality Time Loss (hours)

### 7.2.4.2.1.2 IMM Data Analysis Assumptions

The following assumptions with justification are made in IMM data statistical analysis.

- IMM data consist of crew medical condition fully treated and untreated data. For this analysis, only fully treated data were used which assumes needed medicines, medical devices and equipment are available. In reality, Mars vehicles may not store all needed medicines and equipment. This is considered as a future effort for a refined analysis which considers the tradeoff between needed medical materials and the likelihood of crew illness.
- Any crewmembers' illness was assumed not contagious. This assumption was made because the IMM data does not contain this information. In case the IMM data are revised to include this data, this analysis can be updated.
- Other crew's help time is not counted when one crewmember is sick. Similar to the justification of the prior assumption, the IMM data does not contain this information, and this analysis can be updated once IMM data provides that information.
- Some lines in IMM data sheets which have value zero for event occurrence rate or TXQTL (total time loss) are removed for analysis since these lines will not add value to the analysis.

### 7.2.4.2.1.3 IMM Data Statistical Modeling Approach

The IMM data analysis takes the basic approach of creating medical event buckets with probabilities definitions (i.e., average and confidence estimates). This approach builds the IMM data elements for future potential model extensibility, which can evolve from current deterministic, semi-probabilistic results to full probabilistic and stochastic data to support dynamic scenario analysis and provide probabilistic distributions as outputs. The detailed steps are:

- 1) Time bucket creation, which involves the following sub-steps:
  - 1.1 Define a set of candidate buckets with pre-defined boundaries.
  - 1.2 Run the analysis to observe number of medical events shown in the candidate buckets.
  - 1.3 Down-select a set of final buckets which requires each bucket has minimal expected medical events  $\geq 2$ .

As a starting point, three options of candidate buckets were selected with the following definitions:

Option 1 (Op1): 3 buckets: [0,8 hr], (8, 48 hr], (>48 hr)

Option 2 (Op2): 3 buckets: [0,4 hr], (4, 72 hr], (>72 hr)

Option 3 (Op3): 4 buckets: [0,4 hr], (4, 72 hr], (72, 168 hr], (>168 hr).

Note that as a mathematical convention a square bracket means the interval end point is included in the interval, and a round bracket means the interval end point is excluded in the interval.

Analyzing the IMM data led to the bucketing results in Figure 114. As this figure indicates, Option 2 was selected as the final IMM data bucket set for follow-on IMM data analysis with three buckets: [0, 4hr], (5,72 hr], (>72 hr).

	Bucket Definitions				Total Med. Events	
	[0,8hrs]	(8, 48hrs]	(>48hrs)			
Op1	[0,8hrs]	(8, 48hrs]	(>48hrs)			Not selected (Sample size too small in some Bucket(s))
Number of Medical Events	75	1	4		80	
Op2	[0,4hrs]	(4, 72hrs]	(>72hrs)			Selected
Number of Medical Events	60	16	4		80	
Op3	[0,4hrs]	(4, 72hrs]	(72, 168hrs]	(>168hrs)		Not selected (Sample size too small in some Bucket(s))
Number of Medical Events	60	16	1	3	80	

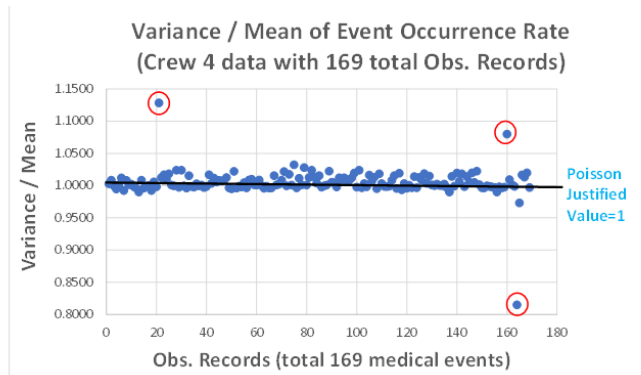
\*Open or close bracket indicates the interval end point is included in the interval.  
Open or close parenthesis indicates the interval end point is excluded in the interval.

**Figure 114. IMM Data Bucket Analysis Result**

- 2) Medical Event Rate and Crew Time Loss (TXTQL) Generation for Crew 4 and Crew 12 data – steps, modeling equations and formulas.

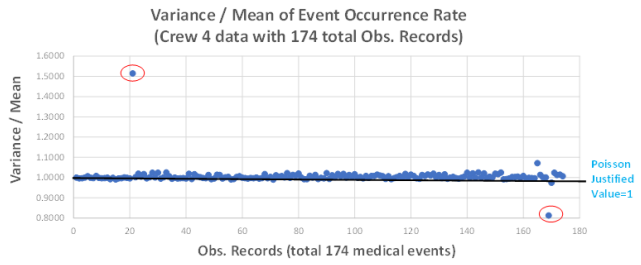
For event occurrence rates, a Poisson Distribution was determined to be adequate to represent the number of occurrences or rate per mission. This is justified by the ratio of variance over Mean close to 1 (Poisson has ratio=1), shown in Figures 115 and 116.





- Conclusions:**
1. Most of 169 ratios are close to 1
  2. 3 points are away from 1 which are due to unique reasons with IMM Team explanation
  3. Poisson distribution is adequate to model Medical Event Occurrence Rate for Crew 4 data

**Figure 115. Justification of Using Poisson Distribution for Medical Event Rate (Crew 4 data)**



- Observations:**
1. Most of 174 ratios are close to 1
  2. 2 points are away from 1 which are due to unique reasons
  3. Poisson distribution is adequate to model Medical Event Occurrence Rate for Crew 12 data

**Figure 116. Justification of Using Poisson Distribution for Medical Event Rate (Crew 12 data)**

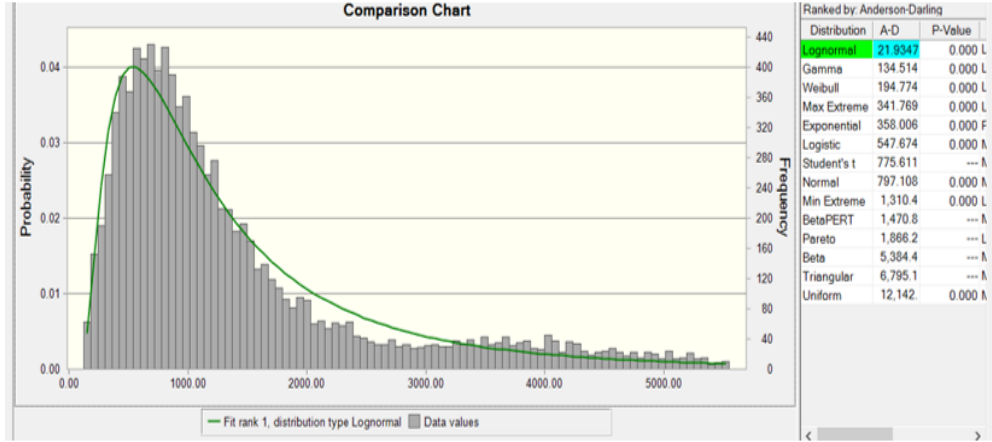
The following specific formulas were used to generate Medical Event Rate and Crew Time Loss distributions:

$$t_E = \text{TXQTL} \times \text{Event}$$

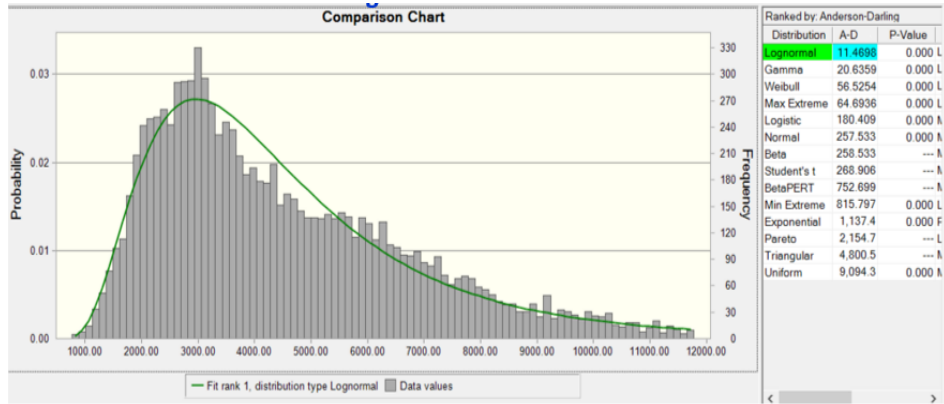
where the occurrence rate is the total quality time loss for that medical event during one mission.

TXQTL and Event Occurrence are considered to be two independent, uncorrelated variables.  $t_E$  is subject to Log-normal distribution, justified by distribution fitting from MCS with sample size  $N=169$  for Crew 4 (Figure 117) and 174 for Crew 12 (Figure 118).





**Figure 117. Log-Normal Fitting for Crew 4 Total Quality Time Loss**



**Figure 118. Log-Normal Fitting for Crew 12 Total Quality Time Loss**

$t_E$  for each medical event is sub-divided into the three medical event buckets:  $[0, 4]$  hr,  $(4, 72]$  hr,  $(>72)$  hr) as  $t_{E1}$ ,  $t_{E2}$ ,  $t_{E3}$ . A Monte Carlo Simulation is performed to generate the total of TXQTL ( $t_{total}$ ) across all medical events:

$$t_{total} = \sum_{i=1}^{169} t_E \text{ for Crew 4 data}$$

$$t_{total} = \sum_{i=1}^{174} t_E \text{ for Crew 12 data}$$

The sum of TXQTL for each of the TXQTL buckets are:

$$t_{Bucket1} = \sum_{i=1}^{N_1} t_E, \quad t_{Bucket2} = \sum_{i=1}^{N_2} t_E, \quad t_{Bucket3} = \sum_{i=1}^{N_3} t_E$$

where  $N_1 + N_2 + N_3 = N = 169$  for Crew 4 and  $= 174$  for Crew 12, with  $N_1 =$  Number of medical events in Bucket1:  $[0, 4]$  hr,  $N_2 =$  Number of medical events in Bucket2:  $(4, 72]$  hr, and  $N_3 =$  Number of medical events in Bucket3:  $(>72)$  hr) respectively. These values ( $t_{Bucket1}$ ,  $t_{Bucket2}$ ,  $t_{Bucket3}$ ) represent the estimate as average (mean) estimates.

The estimates at the 75% confidence level for  $t_{Bucket1}$ ,  $t_{Bucket2}$ ,  $t_{Bucket3}$  (namely,  $t_{Bucket1\_75\%}$ ,  $t_{Bucket2\_75\%}$ ,  $t_{Bucket3\_75\%}$ ), and estimates at the 95% confidence level for  $t_{Bucket1}$ ,  $t_{Bucket2}$ ,  $t_{Bucket3}$  (namely,  $t_{Bucket1\_95\%}$ ,  $t_{Bucket2\_95\%}$ ,  $t_{Bucket3\_95\%}$ ) were generated that provide variability and uncertainty information. The approach for generating 75% and 95% confidence estimates was:

- 1). Varying the MCS generated average estimate  $t_{total}$  to MCS generated 75%tile and 95%tile of

the total (namely,  $t_{total\_75\%}$ , and  $t_{total\_95\%}$ ); 2). Proportionally changing  $t_{Bucket1}$ ,  $t_{Bucket2}$  and  $t_{Bucket3}$  to match  $t_{total\_75\%}$  and  $t_{total\_95\%}$  using the formula:

$$t_{total\_75\%} = C \times (t_{Bucket1} + t_{Bucket2} + t_{Bucket3})$$

After solving for C from the above equation,  $t_{Bucket1\_75\%} = C \times t_{Bucket1}$ ,  $t_{Bucket2\_75\%} = C \times t_{Bucket2}$ , and  $t_{Bucket3\_75\%} = C \times t_{Bucket3}$ .  $t_{Bucket1\_95\%}$ ,  $t_{Bucket2\_95\%}$ , and  $t_{Bucket3\_95\%}$  were generated in similar fashion. This approach was chosen given that the assessment team did not have individual time bucket Monte Carlo data and using pro-ratio provides a good approximation of individual time bucket's confidence estimate.

### 3) Approach to generate Crew 5 to 11 time bucket data.

For IMPRINT Force modeling with IMM time bucket data, the Crew 5 to 11 data may be needed that can support a vehicle crew size tradeoff study. However, the IMM data tables only have Crew 4 and 12 data. Examination of the IMM Crew 4 and 12 data indicates that the event rate is a linear function of the crew size, which makes an interpretation from Crew 4 and 12 medical event rates to Crew 5 to 11 data tables feasible and convenient. However, individual crewmember's medical event time loss is largely independent of crew size as indicated by the IMM data.

In summary, the approach for generating Crew 5 to 11 IMM time buckets was to take linear interpretation between the Crew 4 and 12 for the mean and variance event rates, and crew quality time loss mean and variance values, and conduct MCS to generate the Crew 5 to 11 medical event time bucket data with the analysis results shown in the next section.

#### 7.2.4.2.1.4 IMM Data Analysis Results (as input to IMPRINT Force Model)

Tables 57 to 65 present the IMM data analysis results with individual timing bucket definition, number of expected medical events, and expected crew quality hour time loss in each bucket. The tables for Crew 4 and 12 were used as inputs to IMPRINT Force model for analyzing Mars transit planned and unplanned crew task performance impact. The Crew 5 to 11 tables were developed for this assessment. However, the assessment team evaluated crew sizes greater than four in post-processing rather than by building IMPRINT models for larger crew sizes. Therefore, the Crew 5 to 11 tables were not used in this assessment but are provided for future modelers.

**Table 57. IMM Medical Event Bucket Result for Crew 4**

Result for IMPRINT Model	Crew 4	Event# for TXQTL in (0, 4 hrs]	Event# for TXQTL in (4,72 hrs]	Event# for TXQTL >72 hrs (Top 4 Values)				Total TXQTL
2 bins+4 pts	#events	60	16	4				
Average Case	Ave.TXQTL hrs	1.82	6.87	867.53	267.91	137.60	78.69	1570.56
2 bins+4 pts	#events	62	17	4				
75%tile Case	Ave.TXQTL hrs	1.85	7.17	1020.33	360.36	207.53	136.50	1961.57
2 bins+4 pts	#events	74	23	4				
95%tile Case	Ave.TXQTL hrs	2.00	8.27	1881.45	881.33	601.58	462.29	4165.11

**Table 58. IMM Medical Event Bucket Result for Crew 5**

Result for IMPRINT Model	Crew 5	Event# for TXQTL in (0, 4 hrs]	Event# for TXQTL in (4,72 hrs]	Event# for TXQTL >72 hrs (without Top 4)	Event# for TXQTL >72 hrs Top 4 Values				Total TXQTL
3 bins+4 pts	#events	76	20	1	4				
Average Case	Ave.TXQTL hrs	1.79	6.87	31.65	1040.67	337.23	182.09	110.01	1975.29
3 bins+4 pts	#events	78	21	2	4				
75%tile Case	Ave.TXQTL hrs	1.85	7.29	40.06	1320.24	504.81	308.00	213.56	2723.96
3 bins+4 pts	#events	91	28	5	4				
95%tile Case	Ave.TXQTL hrs	2.02	8.24	64.06	2236.00	1053.74	720.47	552.74	5297.41

**Table 59. IMM Medical Event Bucket Result for Crew 6**

Result for IMPRINT Model	Crew 6	Event# for TXQTL in (0, 4 hrs]	Event# for TXQTL in (4,72 hrs]	Event# for TXQTL >72 hrs (without Top 4)	Event# for TXQTL >72 hrs Top 4 Values				Total TXQTL
3 bins+4 pts	#events	90	24	2	4				
Average Case	Ave.TXQTL hrs	1.82	6.87	43.80	1191.27	401.10	224.55	141.02	2373.79
3 bins+4 pts	#events	94	26	3	4				
75%tile Case	Ave.TXQTL hrs	1.84	7.08	51.91	1487.95	577.81	356.73	249.31	3184.87
3 bins+4 pts	#events	107	33	6	4				
95%tile Case	Ave.TXQTL hrs	2.04	8.19	77.08	2459.77	1156.64	789.68	604.04	5960.87

**Table 60. IMM Medical Event Bucket Result for Crew 7**

Result for IMPRINT Model	Crew 7	Event# for TXQTL in (0, 4 hrs]	Event# for TXQTL in (4,72 hrs]	Event# for TXQTL >72 hrs (without Top 4)	Event# for TXQTL >72 hrs Top 4 Values				Total TXQTL
3 bins+4 pts	#events	106	28	3	4				
Average Case	Ave.TXQTL hrs	1.80	6.88	51.40	1335.15	464.78	266.63	171.75	2775.48
3 bins+4 pts	#events	109	30	4	4				
75%tile Case	Ave.TXQTL hrs	1.86	7.17	60.98	1645.18	648.40	403.42	283.47	3642.10
3 bins+4 pts	#events	124	37	8	4				
95%tile Case	Ave.TXQTL hrs	2.04	8.36	77.08	2660.76	1249.89	851.53	649.42	6590.21

**Table 61. IMM Medical Event Bucket Result for Crew 8**

Result for IMPRINT Model	Crew 8	Event# for TXQTL in (0, 4 hrs]	Event# for TXQTL in (4,72 hrs]	Event# for TXQTL >72 hrs (without Top 4)	Event# for TXQTL >72 hrs Top 4 Values				Total TXQTL
3 bins+4 pts	#events	121	32	4	4				
Average Case	Ave.TXQTL hrs	1.80	6.88	56.75	1454.38	524.66	305.37	201.58	3150.77
3 bins+4 pts	#events	125	34	5	4				
75%tile Case	Ave.TXQTL hrs	1.85	7.24	67.86	1774.34	713.33	445.49	315.72	4066.14
3 bins+4 pts	#events	140	42	9	4				
95%tile Case	Ave.TXQTL hrs	2.05	8.27	86.29	2822.44	1331.35	904.48	689.62	7158.58

**Table 62. IMM Medical Event Bucket Result for Crew 9**

Result for IMPRINT Model	Crew 9	Event# for TXQTL in (0, 4 hrs]	Event# for TXQTL in (4,72 hrs]	Event# for TXQTL >72 hrs (without Top 4)	Event# for TXQTL >72 hrs Top 4 Values				Total TXQTL
3 bins+4 pts	#events	136	36	5	4				
Average Case	Ave.TXQTL hrs	1.80	6.86	61.81	1581.45	582.32	345.26	231.38	3541.13
3 bins+4 pts	#events	140	38	6	4				
75%tile Case	Ave.TXQTL hrs	1.86	7.28	74.00	1909.93	775.28	488.19	347.56	4502.66
3 bins+4 pts	#events	157	47	10	4				
95%tile Case	Ave.TXQTL hrs	2.05	8.19	93.84	2985.90	1407.37	956.39	728.15	7722.44

**Table 63. IMM Medical Event Bucket Result for Crew 10**

Result for IMPRINT Model	Crew 10	Event# for TXQTL in (0, 4 hrs]	Event# for TXQTL in (4,72 hrs]	Event# for TXQTL >72 hrs (without Top 4)	Event# for TXQTL >72 hrs Top 4 Values				Total TXQTL
3 bins+4 pts	#events	151	40	6	4				
Average Case	Ave.TXQTL hrs	1.80	6.88	66.29	1710.16	640.53	384.44	261.18	3941.38
3 bins+4 pts	#events	156	43	7	4				
75%tile Case	Ave.TXQTL hrs	1.86	7.16	79.38	2052.11	840.76	532.42	381.25	4960.73
3 bins+4 pts	#events	173	51	11	4				
95%tile Case	Ave.TXQTL hrs	2.06	8.29	101.07	3172.23	1496.65	1017.14	774.56	8351.21

**Table 64. IMM Medical Event Bucket Result for Crew 11**

Result for IMPRINT Model	Crew 11	Event# for TXQTL in(0, 4 hrs]	Event# for TXQTL in (4,72 hrs]	Event# for TXQTL >72 hrs (without Top 4)	Event# for TXQTL >72 hrs Top 4 Values				Total TXQTL
3 bins+4 pts	#events	166	44	7	4				
Average Case	Ave.TXQTL hrs	1.80	6.87	70.52	1833.39	703.44	425.53	291.58	4348.77
3 bins+4 pts	#events	171	47	8	4				
75%tile Case	Ave.TXQTL hrs	1.87	7.20	84.44	2185.65	909.12	577.24	414.48	5419.76
3 bins+4 pts	#events	189	56	13	4				
95%tile Case	Ave.TXQTL hrs	2.06	8.21	99.25	3339.54	1582.87	1074.17	817.05	8952.62

**Table 65. IMM Medical Event Bucket Result for Crew 12**

Result for IMPRINT Model	Crew 12	Event# for TXQTL in (0, 4 hrs]	Event# for TXQTL in (4,72 hrs]	Event# for TXQTL >72 hrs (without Top 4)	Event# for TXQTL >72 hrs Top 4 Values				Total TXQTL
3 bins+4 pts	#events	181	48	8	4				
Average Case	Ave.TXQTL hrs	1.80	6.86	73.49	1950.16	759.99	462.76	319.61	4736.07
3 bins+4 pts	#events	187	51	9	4				
75%tile Case	Ave.TXQTL hrs	1.87	7.22	88.06	2312.87	971.25	618.30	445.44	5857.69
3 bins+4 pts	#events	205	60	14	4				
95%tile Case	Ave.TXQTL hrs	2.07	8.26	104.48	3500.98	1663.24	1127.78	857.60	9531.73

## 7.2.4.2.2 ECW Data Analysis and Results

### 7.2.4.2.2.1 ECW Data Source

Mars transit ECW data sources are from the ISS historical experience. The ISS original ECW data are stored in an Access database which consists of 10 data fields with more than 250,000 lines of records across the period of January 2005 to June 2023.

The 10 data fields include: Operational Data Reduction Complex (ODRC) time, Log Time, Event Code, Message Text, System, Classification, Event Stat, Annunciation State, Acknowledge State, and Log Entry Type. Figure 119 shows a snippet of the ECW data sheet.

D	E	F	G	H	I	J	K	L	M
ODRC Time	Log Time	Event Code	Message Text	System	Classification	Event_State	Annunciation State	Acknowledge State	Log_Entry_Type
2005_012:16:23:10.000	2005_012:16:23:08.000	5100	Loss of Active IAC Handover to Backup IAC	CNT	C	IA	Suppress	No Ack	Event
2005_012:16:23:10.000	2005_012:16:23:09.000	9415	Primary CC MDM Detected Loss of Sync with CC 2 MDM - LAB	CDH	C	IA	Suppress	No Ack	Event
2005_012:16:23:11.000	2005_012:16:23:09.000	9412	CC MDM Transition to Primary-LAB	CDX	C	IA	Enable	No Ack	Event
2005_012:16:23:11.000	2005_012:16:23:10.000	9414	Primary CC MDM Detected Loss of Sync with CC 1 MDM - LAB	CDH	C	IA	Suppress	No Ack	Event
2005_012:16:23:13.000	2005_012:16:23:11.000	757	BGA 4B Observed vs Last Commanded State Discrepancy-P6	EPS	C	IA	Suppress	No Ack	Event
2005_012:16:23:13.000	2005_012:16:23:11.000	4224	ETCS Loop B GPRV Control Sequence Failed -P1	TCS	C	IA	Suppress	No Ack	Event
2005_012:16:23:15.097	2005_012:16:23:14.000	758	BGA 2B Observed vs Last Commanded State Discrepancy-P6	EPS	C	IA	Suppress	No Ack	Event
2005_012:16:23:20.000	2005_012:16:23:19.000	9415	Primary CC MDM Detected Loss of Sync with CC 2 MDM - LAB	CDH	C	RTN	Suppress	No Ack	Event
2005_012:16:23:21.000	2005_012:16:23:20.000	9414	Primary CC MDM Detected Loss of Sync with CC 1 MDM - LAB	CDH	C	RTN	Suppress	No Ack	Event
2005_012:16:23:36.000	2005_012:16:23:35.000	9415	Primary CC MDM Detected Loss of Sync with CC 2 MDM - LAB	CDH	C	IA	Suppress	No Ack	Event
2005_012:16:24:01.097	2005_012:16:24:00.000	9415	Primary CC MDM Detected Loss of Sync with CC 2 MDM - LAB	CDH	C	RTN	Suppress	No Ack	Event
2005_012:16:24:11.097	2005_012:16:24:09.000	5100	Loss of Active IAC Handover to Backup IAC	CNT	C	RTN	Suppress	No Ack	Event
2005_012:16:25:43.097	2005_012:16:25:41.000	757	BGA 4B Observed vs Last Commanded State Discrepancy-P6	EPS	C	RTN	Suppress	No Ack	Event

**Figure 119. ISS ECW Data Sheet**

### 7.2.4.2.2.2 ECW Data Analysis Assumptions

For Mars transit vehicle ECW data, NASA ISS historical data were used to predict Mars transit similar scenarios. It is understood that though ISS data may not be totally applicable with the design, vehicle operation, and crew task differences between ISS and Mars vehicles and missions, ISS data are the best available data source. The analysis framework and modeling approaches established in this analysis should be adopted and tailored for future updated and refined analyses with Mars vehicle design, operation, and crew task information.

ECW occurrences are treated as independent, but it is understood these events may not be independent. A sensitivity analysis indicates the overlap of ECW events from ISS data is a small percentage of total occurrences (<20%).

ECW data lines with Event State “IA” (in alarm) and Annunciation State “Enable” were used for predicting ECW rate during the 9-month Mars Mission period. The filtered data with these two filters provide relevant ECW data counts.

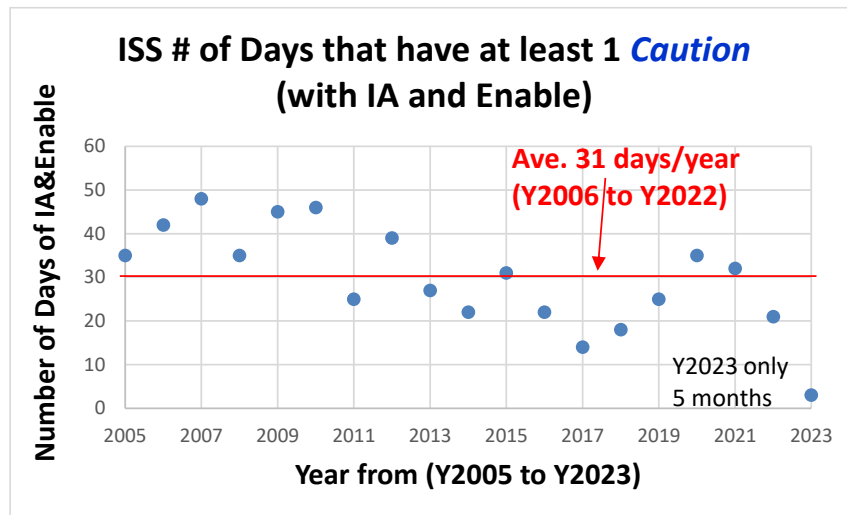
All caution events that occurred on the same day are assumed to be dependent on each other with the same or related cause(s), therefore they are counted as one caution event on that day. Similar assumptions are made for warning events and emergency events. These assumptions lead to the situation that for any day of the Mars transit, one (or warning, or emergency) can occur or no caution (or warning or emergency) will occur.

On the dates that have caution(s), two Mars crewmembers will spend 45 minutes each to handle these events, where the crew time on the event was based on SME interviews. Similarly, on the dates that have warning(s), two crewmembers will spend 45 minutes each to handle these events.

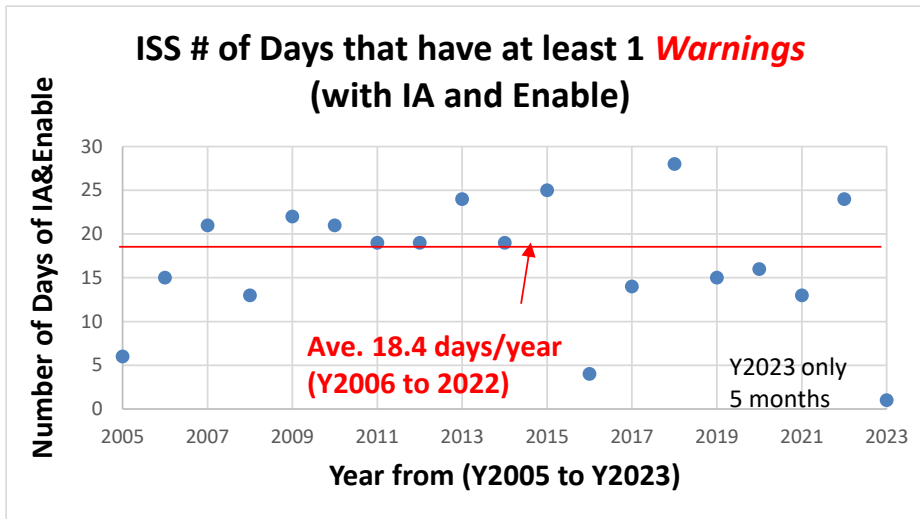
On the dates that have emergency event(s), all crewmembers will be involved to deal with the events with each member spending 120 minutes.

#### 7.2.4.2.2.3 ECW Data Statistical Analysis Approach

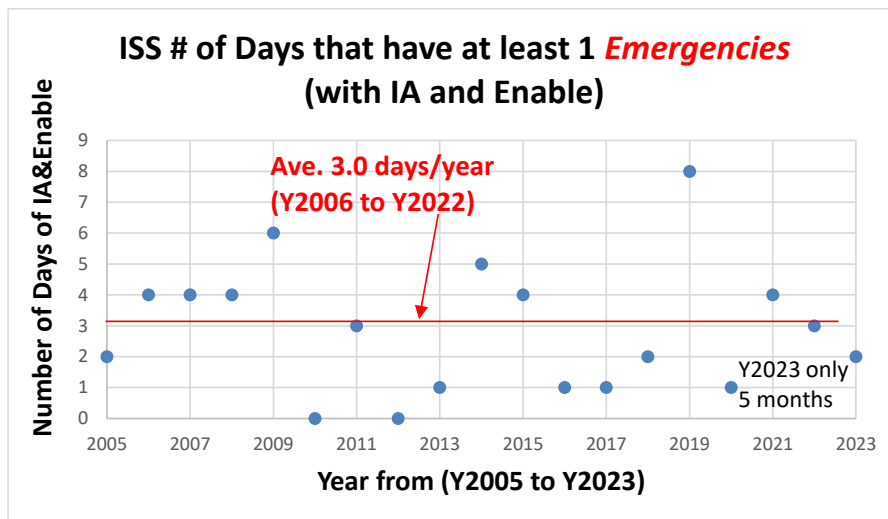
The original ECW data sheet was screened with the filters: Event Type “IA” (in alarm) and Annunciation State “Enable”. This leads to Caution data sheet with 3269 rows, Warning data sheet with 1032 rows, and Emergency data sheet 73 rows. With the approach that for any day, it had at least one Caution (or Warning, or Emergency), or no Caution (or no Warning, or no Emergency). Figures 120, 121, 122 show the trend of caution, warning and emergency occurrences from 2005 to 2023.



**Figure 120. Number of Days that ISS had at least One Caution Event**



**Figure 121. Number of Days that ISS had at least one Warning Event**



**Figure 122 Number of Days that ISS had at least one Emergency Event**

The average and standard deviation of each data set were calculated for the yearly occurrence rate for Caution, Warning, and Emergency, respectively, with the data from 2006 to 2022 since the 2005 and 2023 years had partial data. Since the sample size was too small for obtaining distribution fitting, the average, 75% and 95% confidence estimates of yearly rates were computed with Normal distribution, a Log-normal distribution and a non-parametric distribution. The biggest of the three predicted rates is taken as the final occurrence rate. The reason for selecting these three distributions is: 1) a Normal distribution is symmetric on both tails, but may not be conservative on the right tail, 2) the Log-normal distribution is skewed to the right tail and should be more conservative on the right tail than a Normal distribution, and 3) a non-parametric distribution is not dependent on the distribution choice, but the sample size for this application is not sufficient to predict 95% value. By selecting the biggest of the three, 75% and 95% confidence estimates can be reasonably estimated. The final predicted occurrence rates for Caution, Warning and Emergency are then converted to 9 months from one year by the factor of  $9/12=0.75$ . The next section shows the final results.



#### 7.2.4.2.2.4 ECW Data Analysis Results (as inputs to IMPRINT Model)

Table 66 presents the ECW Analysis results with ECW occurrence rates and crew time needed to deal with the events.

**Table 66. ECW Rates and Crew Time Off\***

	Number of Days during 9 month Mars Mission that have >=1 Cautions, or Warnings, or Emergencies			Crew Times	
	Ave (~50%tile)	75%tile	95%tile	# Crew Members involved	Time (minutes) for each involved crew
<b>Caution</b>	<b>24</b>	<b>30</b>	<b>38</b>	<b>2</b>	<b>45</b>
<b>Warning</b>	<b>15</b>	<b>18</b>	<b>22</b>	<b>2</b>	<b>45</b>
<b>Emergency</b>	<b>3</b>	<b>4</b>	<b>6</b>	<b>All</b>	<b>120</b>

\*For crew time off data, IMPRINT model adds a percentage to account for additional modeling uncertainty.

The interpretation of Table 66 is as follows. Using caution events as an example, on the average, there are 24 days that have caution events during the 9-month Mars transit. Each of these events will cause two crewmembers to each spend 45 minutes to deal with the caution event; 75% and 95% confidence level estimates of days that have caution events are 30 days and 38 days, respectively. The rows showing warning and emergency data are interpreted similarly. These data were input into the IMPRINT Force model. Based on SME inputs, the assessment team only presented results for the average and 75% confidence level.

#### 7.2.4.2.3 Advisory Data Analysis and Result

##### 7.2.4.2.3.1 Advisory Data Source

Mars transit vehicle advisory data source is from ISS historical experience, though maintained in separate database from the emergency, caution, and warning data. The ISS vehicle advisory data are stored in an Access database which consists of 10 data fields with a total more than 430,000 lines of records across the period of January 2005 to June 2023.

The 10 data fields include: ODRC time, Log Time, Event Code, Message Text, System, Classification, Event Stat, Annunciation State, Acknowledge State, and Log Entry Type.

Figure 123 shows a snippet of the advisory data.

	C	D	E	F	G	H	I	J	K	L
	ODRC Time	Log Time	Event Code	Message Text	System	Classification	Event_State	Annunciation State	Acknowledge State	Log_Entry_Type
1	2005_201:00:00:03.597	2005_200:23:26:10	4177	RPCM S02B_D Observed vs EPS		A	RTN	Enable	No Ack	Unknown
2	2005_201:00:17:03.597	2005_201:00:16:55	5520	Primary PMCU MDM Detec CDH		A	IA	Enable	No Ack	Event
3	2005_201:00:17:23.597	2005_201:00:17:22	5520	Primary PMCU MDM Detec CDH		A	RTN	Enable	No Ack	Event
4	2005_201:08:30:43.597	2005_201:08:26:55	5520	Primary PMCU MDM Detec CDH		A	IA	Enable	No Ack	Command
5	2005_201:08:30:43.597	2005_201:08:27:22	5520	Primary PMCU MDM Detec CDH		A	RTN	Enable	No Ack	Command
6	2005_201:08:30:43.597	2005_201:08:30:11	5520	Primary PMCU MDM Detec CDH		A	IA	Enable	No Ack	Command
7	2005_201:08:30:43.597	2005_201:08:30:44	5520	Primary PMCU MDM Detec CDH		A	RTN	Enable	No Ack	Command
8	2005_201:08:56:03.597	2005_201:08:56:00	6725	Lab LTL PPA HR Flow Sensc TCS		A	IA	Enable	No Ack	Event
9	2005_201:08:56:43.597	2005_201:08:56:38	6725	Lab LTL PPA HR Flow Sensc TCS		A	RTN	Enable	No Ack	Event
10	2005_201:10:06:53.597	2005_201:10:06:53	5520	Primary PMCU MDM Detec CDH		A	IA	Enable	No Ack	Event

**Figure 123. ISS Vehicle Advisory Data Sheet**



#### **7.2.4.2.3.2 Advisory Data Analysis Assumptions**

For Mars transit vehicle advisory, NASA ISS historical data were used to predict Mars transit similar scenarios. It is understood that ISS vehicle advisory data may not be totally applicable with the design, vehicle operation, and crew task differences between ISS and Mars vehicles and missions, but ISS data are the best available data source. Besides, the analysis framework and modeling approaches established in this project should be adopted and tailored for future updated or refined analyses with Mars vehicle design, operation, and crew task information.

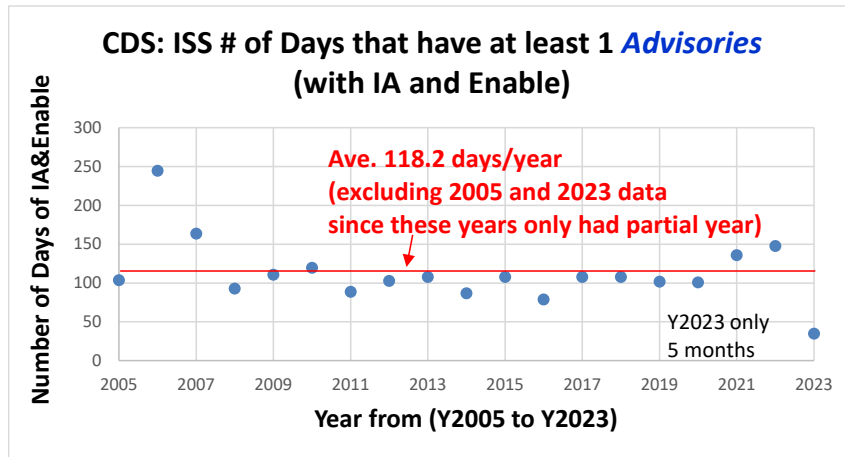
Advisory data lines with Event State “IA” and Annunciation State “Enable” were used for predicting Mars Vehicle advisory rate during the 9-month Mars transit period.

All advisory events occurred on the same day within the same system and assumed to be dependent on each other with the same or related cause(s), therefore they are counted as one advisory event on that day for that system. Advisory events that occurred across different vehicle systems on the same day are assumed to be independent of each other. Consequently, all advisory records are grouped into six vehicle systems for occurrence rate analysis independently. These six systems are Command and Data Handling System (CDS), Communication and Tracking System (CNT), ECLSS, Electrical Power System (EPS), Motion Control System (MCS), and Thermal Control System (TCS). There are other systems listed in the ISS historical data (e.g., the Crew Health Care (CHC) and Structures and Mechanisms (SNM)), which are ignored for Mars transit analysis since the advisory counts during the entire ISS operation for these systems were negligible.

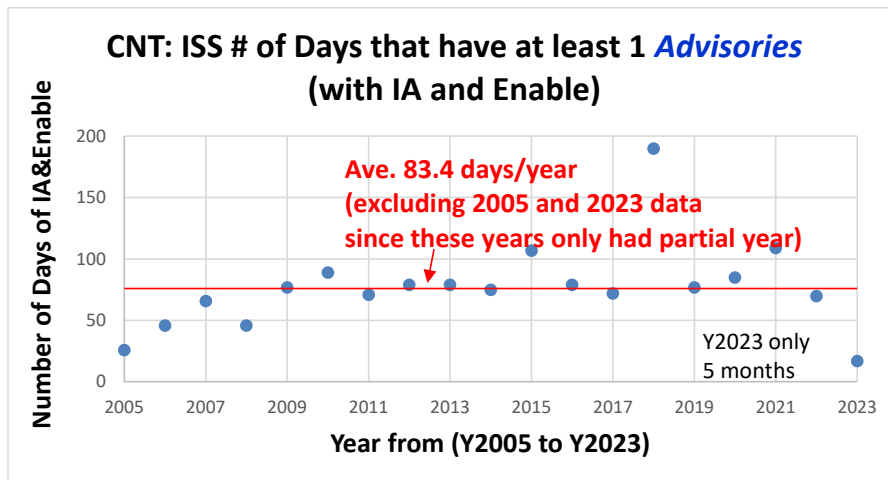
The above two assumptions lead to the situation that for any day of the Mars transit, either one advisory for each system can occur or no advisory will occur for that system. On the dates that have advisories occurring on a system, one crewmember will be involved and will spend 15 minutes to deal with the issue, as opposed to 45 minutes for cautions and warnings. The crew time on the event was based on SME interviews, and this time estimate can be refined for future models to consider the uniqueness of each subsystem.

#### **7.2.4.2.3.3 Advisory Data Advisory Data Statistical Analysis Approach**

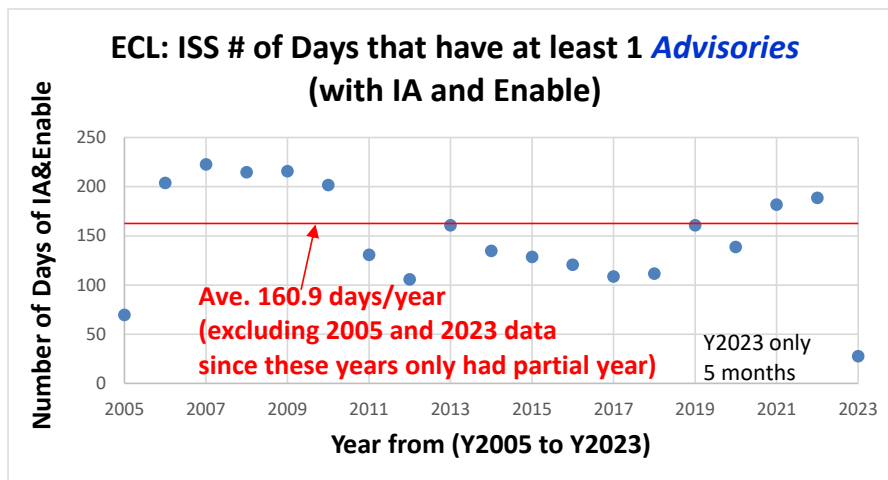
The ISS Advisory data sheet was screened with the filters: Event Type “IA” and Annunciation State “Enable”. This leads to screened down advisory sheet with 208,566 lines of records. With the approach that for any day for any of the six systems, it had at least one advisory event or no advisory. Figures 124 to 129 show the trends of advisory data for each of the six systems respectively across the years 2005 to 2023.



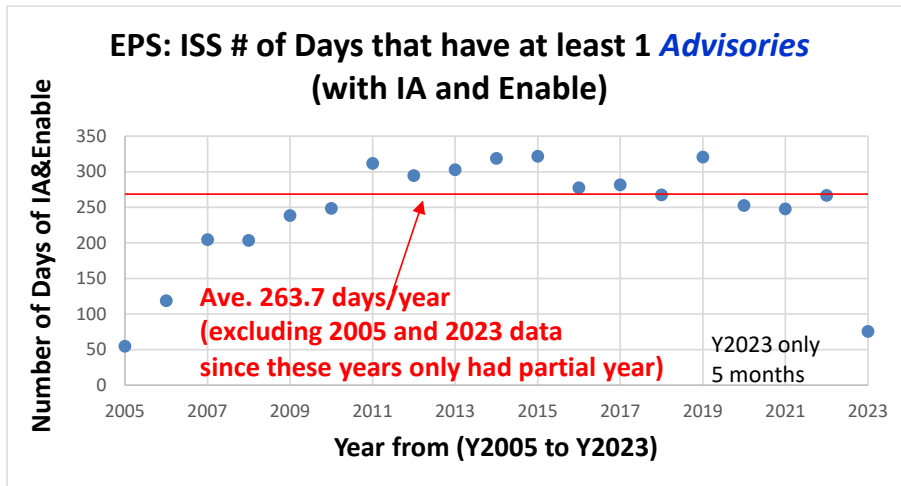
*Figure 124. Number of Days that ISS had at least 1 Advisory for CDS*



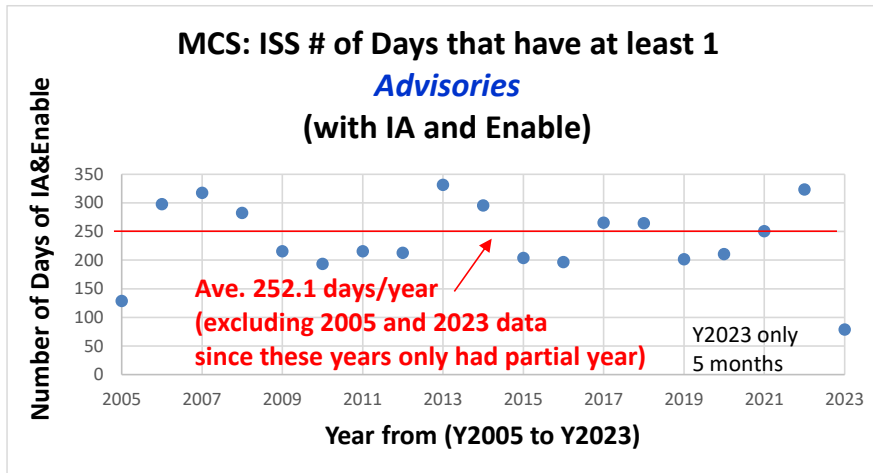
*Figure 125. Number of Days that ISS had at least 1 Advisory for CNT*



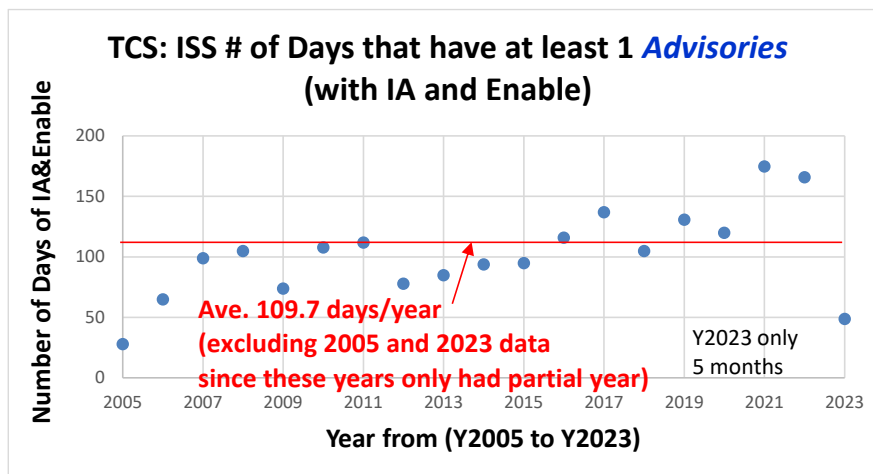
*Figure 126. Number of Days that ISS had at least 1 Advisory for ECL*



*Figure 127. Number of Days that ISS had at least 1 Advisory for EPS*



*Figure 128. Number of Days that ISS had at least 1 Advisory for MCS*



*Figure 129. Number of Days that ISS had at least One Advisory for TCS*

The average and standard deviation of each data set for each of the six systems were calculated for the yearly occurrence rate for advisory events with the data from 2006 to 2022 since years

2005 and 2023 had partial year data. The sample size is too small for distribution fitting, so the average 75% and 95% confidence estimates of yearly rates were computed with the Normal Distribution, Log-normal distribution, and Non-parameter methods. The largest of the three predicted rates is taken as the final occurrence rate. The reasons for selecting these three distributions are: Normal is symmetric on both tails but may not be conservative on the right tail; the Log-normal is skewed to the right tail and is more conservative on the right tail than Normal; and the Non-parameter method is not dependent on the distribution choice, but the sample size is not sufficient to predict 95% value. By selecting the largest of the three, 75% and 95% confidence estimates can be reasonably estimated. The final predicted occurrence rates for advisory events are converted to 9 months from 1 year by the factor 0.75. The next section shows the final results.

#### 7.2.4.2.3.4 Advisory Data Analysis Results (as inputs to IMPRINT Model)

Table 67 presents the advisory data analysis result with advisory occurrence rates for each of the six systems and crew time needed to deal with the events.

*Table 67. Vehicle Advisory Event Rates for Each System and Crew Time Off \**

	Number of Days during 9 month Mars Mission that have >=1 Advisories			Crew Times	
	Ave (~50%tile)	75%tile	95%tile	# Crew Members involved	Time (minutes) for each involved crew for that system
CDS	89	109	184	1	15
CNT	63	79	143	1	15
ECL	121	152	178	1	15
EPS	201	228	269	1	15
MCS	190	222	255	1	15
TCS	83	98	132	1	15

\*For crew time off data, IMPRINT model adds a percentage to account for additional modeling uncertainty.

The interpretation of the Table 67 is as follows. Using CDS system as an example, on the average, there are 89 days during 9 months of Mars mission that will have CDS advisory events. Each of these days will cause one crewmember an estimated 15 minutes to deal with the CDS advisory event. 75% and 95% confidence level estimates of days that have CDS advisory events are 109 days and 184 days, respectively. The results of the other five system rows are interpreted similarly. These data were input into the IMPRINT Force model.

#### 7.2.4.2.4 Vehicle Maintenance Data Analysis and Results

##### 7.2.4.2.4.1 Vehicle Maintenance Data Source

Mars transit vehicle maintenance data sources were provided by NASA LaRC's Space Mission Analysis team via the file: Supportability Maintenance Crew Time Demand, Presentation, November 21, 2022. This team developed an Exploration Crew Time Model (ECTM), which determines the residual time available for crew to perform science and utilization activities given

assumptions on crew time for maintenance [ref. 73]. For their model, the team derived a corrective maintenance event rate for orbital replacement unit (ORU) failure rates and engineering estimates of individual ORU remove and replace (R&R) hours or non-R&R hours (e.g., troubleshooting, cleaning or calibration) using ISS historical data. The LaRC team used a bucket approach for their data shown in Table 68. The data were further analyzed by the assessment team to derive Mars Transit vehicle maintenance event rate and crew time with average 75% confidence and 95% confidence level estimates to support Mars Transit Crew modeling. The table shows the projected Mars 270-day mission vehicle corrected maintenance rate and crew time in each maintenance time bucket. The time buckets ([0, 1.5 hr], (1.5,3 hr], (3,5], (5,10], (10,15 hr], and (>15 hr)) were derived to reflect the uniqueness of historical ISS maintenance hour bins.

**Table 68. Vehicle Corrected Maintenance Rate and Crew Time Involved**

Op1	Bucket	[0, 1.5]	(1.5, 3]	(3, 5]	(5, 10]	(10, 15]	(>15]
	Avg. Number of Maintenance Events	2.73	6.44	3.32	0.00	1.26	0.66
	SD Number of Maintenance Events	1.68	2.72	1.88	0.00	1.15	0.83
	Avg. Crew Maintenance Hours Per Event	0.80	2.15	3.74	#N/A	11.21	17.03
	SD Crew Maintenance Hours Per Event	0.13	0.22	0.29	#N/A	0.30	0.00
	Avg. of Total Crew Maintenance Hours	2.20	13.89	12.03	0.00	14.48	11.26
	SD of Total Crew Maintenance Hours	1.37	5.89	6.84	0.00	13.20	14.13
Op2	Bucket	[0, 3]	(3, 5]	(5, 10]	(10, 15]	(>15]	
	Avg. Number of Maintenance Events	9.17	3.32	0.00	1.26	0.66	
	SD Number of Maintenance Events	3.20	1.88	0.00	1.15	0.83	
	Avg. Crew Maintenance Hours Per Event	1.40	3.74	#N/A	11.21	17.03	
	SD Crew Maintenance Hours Per Event	0.69	0.29	#N/A	0.30	0.00	
	Avg. of Total Crew Maintenance Hours	16.09	12.03	0.00	14.48	11.26	
	SD of Total Crew Maintenance Hours	6.04	6.84	0.00	13.20	14.13	
Op3	Bucket	[0, 5]	(5, 10]	(10, 15]	(>15]		
	Avg. Number of Maintenance Events	12.49	0.00	1.26	0.66		
	SD Number of Maintenance Events	3.71	0.00	1.15	0.83		
	Avg. Crew Maintenance Hours Per Event	1.84	#N/A	11.21	17.03		
	SD Crew Maintenance Hours Per Event	1.12	#N/A	0.30	0.00		
	Avg. of Total Crew Maintenance Hours	28.12	0.00	14.48	11.26		
	SD of Total Crew Maintenance Hours	9.12	0.00	13.20	14.13		

#### 7.2.4.2.4.2 Vehicle Maintenance Data Analysis Assumptions

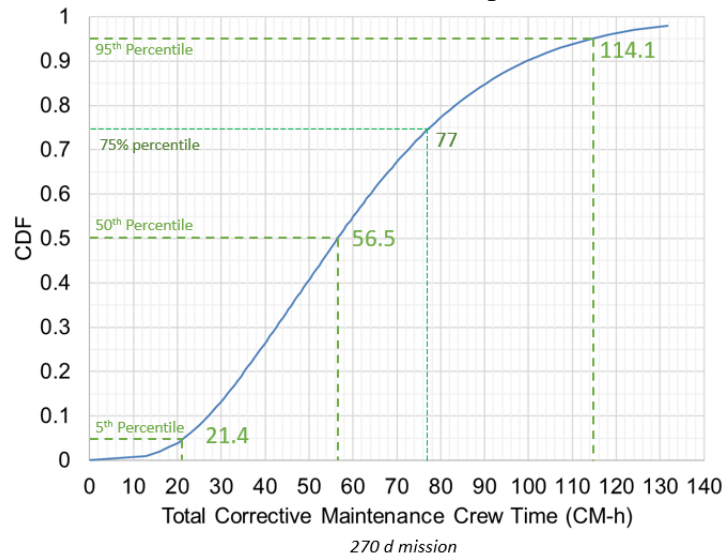
The LaRC team provided historical failure-rate based vehicle maintenance data as the starting point for the Mars transit scenario vehicle maintenance data analysis. There might be a number of data pieces that were not analyzed due to data availability or other reasons in the team’s data and analysis. This data is the best and the most relevant. In addition, the analysis framework and modeling approaches established in this assessment should be adopted and tailored for future updated or refined analyses with the team’s update, and Mars vehicle design, operation, and crew task information.

The LaRC team data were primarily based on the analysis of corrective maintenance rate and crew hours. The team analysis indicated that the only scheduled maintenance for Mars vehicles during Mars transit 270-day mission is an advance oxygen generation assembly (OGA) hydrogen sensor ORU with one-time maintenance on Day 201 with a total of 0.81 crewmember hours (CM-h). Therefore, scheduled maintenance is not counted in this analysis. Once Mars mission ConOps is defined with possibly more scheduled maintenance tasks planned, this analysis can be updated with increased maintenance rates and crew time fed to the IMPRINT Force model.

### 7.2.4.2.4.3 Vehicle Maintenance Data Statistical Analysis Approach

Based on Table 68, Option 1 (Op1) data set was used for Mars transit maintenance task prediction. The reason for selecting Op1 (versus Op2 and Op3) is that Op1 has the most time buckets. In the future, if a simplified analysis with less time buckets is performed, Op2 and Op3 tables can be used.

Table 68’s total crew time was anchored to the LaRC team’s total maintenance time plot shown in Figure 130 with 75% confidence level time of 77 hours and 95% confidence level time of 114.1 hours. Individual bucket data (e.g., number of events and crew times) are adjusted proportionally to make total crew time match Figure 130 75% confidence and 95% confidence levels values. The resultant final time bucket data table is presented in the next section.



**Figure 130. Cumulative Distribution Function for Total Corrective Maintenance Crew Time (from Langley’s analysis briefing dated November 21, 2022)**

### 7.2.4.2.4.4 Vehicle Maintenance Data Analysis Results (as inputs to IMPRINT Model)

Table 69 presents Mars 270-day transit mission maintenance task rate and crew time for each event.

**Table 69. Predicted Maintenance Task Rates and Crew Times for Mars 270-day Transit Mission**

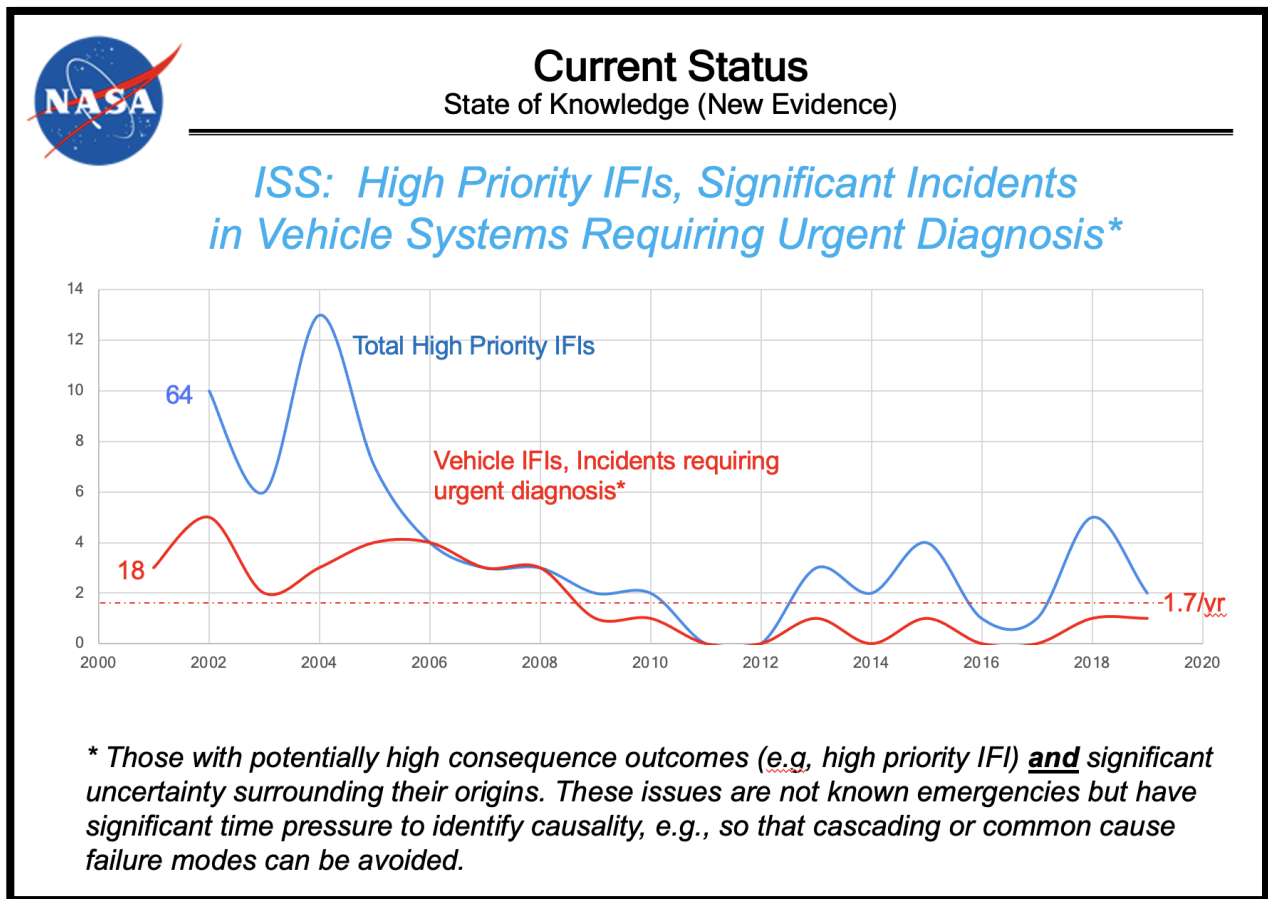
Maintenance Data (Corrective Maintenance)		Bucket Definition					Total
		[0, 1.5 hrs.]	(1.5, 3]	(3, 5]	(10, 15]	(>15)	
Average Case	Number of events	2.73	6.44	3.32	1.26	0.66	14.41
	Crew time (hrs.) per event	0.80	2.15	3.74	11.21	17.03	53.86
75% confidence case	Number of events	3.27	7.70	3.97	1.51	0.79	17.23
	Crew time (hrs.) per event	0.96	2.57	4.47	13.41	20.36	77.00
95% confidence case	Number of events	3.97	9.37	4.83	1.83	0.96	20.98
	Crew time (hrs.) per event	1.16	3.13	5.44	16.32	24.78	114.10

## 7.2.4.2.5 Major Incident/Unforeseen Event Data Analysis and Results

### 7.2.4.2.5.1 Major Incident/Unforeseen Event Data Source

For the Mars transit scenario, there are nominal, time-critical tasks that the crew will need to perform without the real-time support of the MCC (e.g., piloting, EVA operations, certain robotics operations, and vehicle system commanding that requires real-time responses). Most critically is the real-time expertise needed to respond to unforeseen failures with potential loss of crew/loss of mission consequences and short time-to-effect.<sup>12</sup>

For the Mars transit unforeseen failure rate analysis, ISS historical data was used. Figure 131 depicts the yearly rate for the ISS Total High Priority IFIs and Vehicle IFIs requiring crew attention for urgent diagnosis from the year 2001 to 2019. The Vehicle IFIs data (red curve) are used to estimate the Mars transit major incident/unforeseen event rate for the 9-month transit mission duration.



**Figure 131. ISS High Priority IFIs and Vehicle System IFIs**  
[ref. 38]

<sup>12</sup> As noted, the assumption by the HSIA Risk Team is that an unforeseen failure that must be safed within ~24 hours and up to ~72 hours will require the expertise within the Mars crew to respond, given the communication delay/blackout with Earth.

#### **7.2.4.2.5.2 Major Incident/Unforeseen Event Data Analysis Assumptions**

For the Mars transit major incident/unforeseen event data analysis, ISS historical data were used to predict Mars transit similar scenarios. It is understood that ISS data may not be totally applicable with the design, vehicle operation, and operating environment differences between ISS and Mars vehicles and missions, but ISS data are the best available. In addition, the analysis framework and modeling approaches established in this assessment should be easily adopted and tailored for future updated or refined analyses with Mars vehicle design, operation, and unique operating environment.

Mars transit IFIs rate was held constant during the 9-month mission. Though there were visible trends in Figure 131 that ISS Total High Priority IFI rate and Vehicle IFI annual rates were decreasing from 2001 to 2019, the decreasing trend is not consistent. Also, the underlying reasons of ISS IFIs may not be applicable to the Mars vehicle and operations, and uncertainty exists for the similarity between ISS and Mars missions. Therefore, ISS IFI data will be analyzed to derive average annual IFI rate then confidence estimates will be estimated to cover the uncertainty.

For each of the unforeseen events, all crewmembers will be required to respond to the event spending an estimated 2 to 4 days based on SME interviews to work on the issue. This is significantly longer than the 45 minutes to respond to known caution and warning events, where known events are those failures that have associated procedures for the crew to execute.

#### **7.2.4.2.5.3 Major Incident/Unforeseen Statistical Analysis Approach**

ISS Vehicle IFI data are tabulated in Table 70 year-by-year from 2001 to 2019. Average IFI rate/year is calculated to be 1.74/year. Mars transient vehicle yearly IFI rate is estimated from the bigger of Poisson's and Non-parameter estimate from the ISS data.



**Table 70. ISS Vehicle IFI Rate Per Year (from 2001 to 2019)**

Year	IFIs	Vehicle IFIs
2001	0	3
2002	10	5
2003	6	2
2004	13	3
2005	7	4
2006	4	4
2007	3	3
2008	3	3
2009	2	1
2010	2	1
2011	0	0
2012	0	0
2013	3	1
2014	2	0
2015	4	1
2016	1	0
2017	1	0
2018	5	1
2019	2	1
Ave		1.74

Average IFI rate of 1.74 is taken to be Poisson distribution mean rate, and 75% and 95% confidence level estimates are estimated per the formula:

$$\text{IFI yearly rate with } \gamma\% \text{ confidence} = \chi_{df}^2(\gamma\%, df)$$

where  $\gamma\%$  is the confidence level,  $df$  is the degrees of freedom of the  $\chi^2$  statistic with  $df = 2 \times$  Number of years+2,  $\chi_{df}^2(\gamma\%, df)$  is the  $\chi^2$  distribution percentile with  $\gamma\%$  probability and degrees of freedom  $2 \times$  Number of years+2.

Table 71 tabulates the IFI yearly rate estimates from Poisson, Non-parameter method, and the bigger of the two. The last column covers the yearly rate to 9-month transit duration.

**Table 71. Mars Transit Mission IFI Rate**

Confidence estimate of IFI rate	Yearly (Poisson)	Yearly (non-para)	Larger of the two	IFI rate for 270 days
Ave (~=50%tile)	1.74	1.74	1.74	1.30
75%tile	1.99	3.00	3.00	2.25
95%tile	2.32	5.00	5.00	3.75

**7.2.4.2.5.4 Major Incident/Unforeseen Event Analysis Results (as inputs to IMPRINT Model)**

Table 72 presents the predicted Mars transit major incident/unforeseen event rates for the 9-month transit duration and crew time off result. The interpretation of the Table 72 is as follows. During the 9-month mission, it is expected to have 1.3 unforeseen IFI events occurring.

Each occurrence will lead to crewmembers spending 2 to 4 days to deal with each occurrence therefore, for average estimate of the rate of 1.3 events, it will cause each and every crewmember 2.6 to 5.2 days to work. 75% and 95% confidence level estimates of the unforeseen event rates are 2.25 and 3.75, respectively, that will cause each and every crewmember 4.5 to 9 days, and 7.5 to 15 days, respectively. These data were input into the IMPRINT Force model.

**Table 72. Predicted Mars Transit Mission  
Unforeseen Event Rate and Crew Time-off**

IFI Rate for Mars Transit Mission Unforeseen Events Estimated from ISS historical IFIs		Crew Time (all crew members) (2-4 days)
Confidence estimate of IFI rate	IFI rate for 270 days	Crew Time for 270 days for each crew member (rate x (2,4))
Ave (~=50%tile)	1.30	2.6- 5.2 days
75%tile	2.25	4.5 - 9 days
95%tile	3.75	7.5 - 15 days

#### 7.2.4.2.6 MCC Task Data Analysis and Results

The final set of data represents those nominal, real-time tasks performed by ISS flight controllers that will need to be shifted onboard given the communication delay between Earth and Mars. The model does not address tasking due to communication blackout. Off-nominal events were addressed in the IMM data, the ECWA data, and the unforeseen failure data. While the assessment team recognizes that some of these tasks may be candidates to automate in the future, the team chose to include all tasks currently performed by humans and not anticipated to be automated in this initial build of the Mars Transit Crew model. If any of these tasks become automated, then they can be removed from future IMPRINT models.

##### 7.2.4.2.6.1 MCC Task Data Sources

The assessment team worked with a flight director and a payloads operations director to develop a list of assumptions for Mars missions, assuming continual time-delayed support from the MCC and the POIC (i.e., enabled by the upgrades described in Section 6.3.1).

##### *Assumptions for Mars:*

- MCC is prime for nominal planning (alternately, for crew behavioral health, some planning to crew).
- MCC is prime for nominal commanding with a communication delay.
- MCC is prime for resource allocation (e.g., power, thermal, bandwidth, data, O<sub>2</sub>, N<sub>2</sub> vacuum access, etc.).
- MCC is prime for console analytic tools that can be performed with a communication delay.
- Crew is prime for commanding for tasks requiring real-time or near real-time verification.
- Crew is prime for tasks with time constraints.

- Crew is prime for go-no-go calls requiring real-time data (e.g., crew lock depress).
- Crew is prime for tasks requiring real-time monitoring (e.g., some robotics operations).
- Crew is prime for tasks requiring real-time communication (e.g., IV crew).
- Crew is prime for tasks with bandwidth limitations.
- Crew is prime for console analytic tools impacted by the communication delay or bandwidth limitations.

Additionally, all crewmembers will stay on the same sleep schedule, unless one of the above conditions requires them to be awake.

The assessment team conducted structure interviews of the flight control team to document MCC tasks that would likely be shifted to the Mars crew. Each member of the flight control team was provided a briefing of the assessment along with the assumptions on Mars tasks listed above. The following flight control disciplines provided task information to the team.

- CRONUS, responsible for the C&DH and the communication and tracking system.
- Station Power Articulation Thermal Analysis (SPARTAN), responsible for the electrical power system and external thermal control system.
- Integration and Systems Engineer (ISE), responsible for monitoring docked visiting vehicles.
- Plug-in-plan Utilization Officer (PLUTO), responsible for the Ops LAN and joint Station LAN.
- Inventory Stowage Officer (ISO), responsible for inventory and stowage.
- Operations Planner (Ops PLAN), responsible for coordinating planning and for building the crew's timeline.
- Visiting Vehicle Officer (VVO), responsible for visiting vehicle trajectories.
- Operations Support Officer for Maintenance (OSO MAINT), responsible for IV maintenance.
- Operations Support Officer for Mechanisms (OSO MECH), responsible for vehicle mechanisms (including docking mechanisms).
- BME, a biomedical engineer responsible for crew health countermeasures.
- Surgeon, responsible for crew medical health.

ETHOS, responsible for the environmental control and life support systems and for internal thermal control, and Attitude Determination and Control Officer (ADCO), responsible for attitude determination and motion control, were not able to support. The assessment team did not include EVA or robotics operations in the model because it is unknown whether EVA or robotics operations would occur on the transit and, if they did, they would be included within work hours.

The tasks identified included daily health and status check on IT equipment (i.e., Ops LAN work), safing for maintenance tasks (e.g., powering down equipment prior to performing maintenance), and tasks associated with daily operations (e.g., adjusting daily schedules<sup>13</sup> and configuring software applications). Additionally, the assessment team gathered SME inputs on training hours per week beyond ISS refresher training to ensure the crew would be able to retain Mars lead qualifications throughout their mission (see Section 7.2.5). Table 73 lists the tasks

---

<sup>13</sup> 20 minutes per day is based on personal communication with ARC human factors researcher Dr. J. Marquez in her analog research conducted using advanced self-scheduling tools.

included in the model or in post-processing. This table lists tasks identified in the structured interviews that were not included in the modeling (e.g., water sampling).

**Table 73. MCC Tasks Shifted to Mars Crew**

Nominal Task Description	Frequency			# of Crewmembers Involved	Mars Crew Time	MCC Position
	Daily	Weekly	Monthly+			
<b>Tasks Added to Transit Model Schedule</b>						
Conduct preventative maintenance, including daily health and status checks, on operational computers that may include off-nominal responses (Ops LAN work)	x			1	1 hour	PLUTO
<b>Time Added to Transit Model Maintenance Data (for Planned Maintenance (as a tax) and in LARC DATA for Corrective Maintenance (R&amp;Rs))</b>						
Perform safing for maintenance tasks (such as removing power, fluid flow, modifying data to safely perform maintenance task)	x	x	x		Add 25% of crew task time.	ETHOS and OSO MAINT
<b>Tasks Accounted for Post-Modeling</b>						
Self-scheduling using Playbook	x			All	20 minutes	Ops PLAN
Use Plug-in-Plan (PIP) tool to conduct analysis for unplanned hardware movement	x			1	10 minutes	PLUTO
Conduct software setups in preparation for tasks (such as payload experiment, medical exam, crew video conference, phone call)	x			All	10 minutes	PLUTO (limited ground user)
Locate an item using Inventory Management System (IMS) database	x			1	10 minutes	ISO
<b>Training Hours Accounted for Post-Modeling</b>						
In-mission initial and refresher training (including maintaining lead quals.)		x		All	4 hours	Multiple
<b>NOT INCLUDED IN TRANSIT MODEL: These tasks are not related to quiescent operations</b>						
Perform "Go/no Go" calls for activity (such as EVA, docking, or undocking)			x			FCR Team
<b>NOT INCLUDED IN TRANSIT MODEL: This task is &gt; 2 years</b>						
Fluid system servicer operations (filling thermal cooling loops with water)			x			OSO-MAINT
<b>NOT INCLUDED IN TRANSIT MODEL: These tasks are being automated</b>						
Water sampling <sup>1</sup>		x				BME
Air sampling <sup>2</sup>			x			BME
Surface sampling <sup>3</sup>			x			BME
<b>NOT INCLUDED IN TRANSIT MODEL: These tasks are recommended to be automated for future missions.</b>						
Weekly ECLSS equipment calibration		x				ETHOS
Activation/deactivation of ECLSS equipment (e.g., switching from scrubber 1 to scrubber 2).		x				ETHOS
Perform safing for weekly housekeeping tasks (such as powering down smoke detectors)		x				OSO-MAINT

1. On ISS, some water sampling data is produced on orbit and downlinked and some samples are brought to the ground for analysis

2. On ISS, air sampling data using the grab sample container (GSC) and formaldehyde monitoring kit (FMK) is analyzed on ground

3. On ISS, surface microbes are counted on orbit and genomes are analyzed on ground

#### 7.2.4.2.6.2 MCC Task Analysis and Results (as inputs to IMPRINT Model)

While there is uncertainty of the task duration, the assessment team did not conduct statistical analysis on this data set given that these are single inputs from a single source. The frequency and duration of the times in the IMPRINT model are those shown in Table 73.

#### 7.2.4.3 Assumptions and Model Limitations

Activities in an IMPRINT Force model include planned and unplanned tasks. All planned activities in a Force model are input into schedules that run throughout the duration of model execution. Unplanned activities in a Force model are scheduled according to predicted frequencies of occurrence with durations and crewmember requirements also scripted according to predictive data. All activities, planned and unplanned, are assigned priority numbers (i.e., lower numbers are higher priorities) that dictate whether crewmembers will interrupt an ongoing or scheduled activity to perform a newly scheduled task.

For unplanned events to occur and be handled as scheduled, it was necessary to make them a higher priority than scheduled activities. Table 74 shows a snippet from the Activities Priority Table in the combined IMPRINT Forces model. Long-term injuries (i.e., greater than 72 hours) were forced to be the highest priority for a few reasons. First, it was assumed they would be debilitating enough to take a crewmember from scheduled activities and to keep them from

responding to other unplanned events. Second, as a noted limitation or opportunity for improvement with the Force model, if they were not the highest priority, and an injured crewmember was requested to respond to another high priority emergency, then the model would end their injured state which would have been unrealistic.

It was assumed that sleep would take priority over responding to crew advisories, but crew advisories occurring during a period where all crewmembers were sleeping would be handled when a crewmember became available. Otherwise, most unplanned events were higher priority than planned activities.

In addition to sleep, crew exercise is a high priority activity on extended duration space missions. It was therefore given a higher priority than work hours and other planned activities.

**Table 74. IMPRINT Activity Priority Table**

Priority	Name	Type
1	MedicalEvent_GT72_Crew1	Unplanned
1	MedicalEvent_GT72_Crew3	Unplanned
1	MedicalEvent_GT72_Crew2	Unplanned
1	MedicalEvent_GT72_Crew4	Unplanned
3	AllCrewEmergency	Unplanned
5	UnforeseenEvent	Unplanned
10	Crew3_4Warning	Unplanned
10	Crew1_2Warning	Unplanned
12	MedicalEvent_4-72_Crew2	Unplanned
12	MedicalEvent_4-72_Crew3	Unplanned
12	MedicalEvent_4-72_Crew4	Unplanned
12	MedicalEvent_4-72_Crew1	Unplanned
16	Crew1_2Caution	Unplanned
16	Crew3_4Caution	Unplanned
18	MedicalEvent_0-4_Crew2	Unplanned
18	MedicalEvent_0-4_Crew4	Unplanned
18	MedicalEvent_0-4_Crew1	Unplanned
18	MedicalEvent_0-4_Crew3	Unplanned
35	Sleep	Planned
38	Crew3Advisory	Unplanned
38	Crew4Advisory	Unplanned
38	Crew2Advisory	Unplanned
38	Crew1Advisory	Unplanned
41	Exercise	Planned
42	Work Hours	Planned

Another noted limitation of the IMPRINT model is that it is not possible to change crewmember schedules during a model run. Therefore, each crewmember stayed on the same 7-day repeating schedule for the entire run duration. This necessitated model data post processing. For example, when a crewmember suffered a major injury or illness, model output reports showed the full duration of this event, but the event took time from every planned activity, including sleep, meals, and other personal time. These activities were added back to the model results post model report generation according to the assumptions noted in Table 75.

**Table 75. Post Processing “Give Back” to Some Activities**

<b>Activity Grouping</b>	<b>Long-Term Injury Give Back (%)</b>
Sleep	100
Postsleep	100
Conferences	50
Exercise	50
Prepare for Work (PFW)	None
Work Hours	None
Midday Meal	100
Presleep	100
Housekeeping	None
Off Duty	100

It was assumed that an injury may take ability to participate in crew conferences and to exercise depending on the nature of the injury, but not all capability. 50% was an arbitrary assumption on the amount of time given back in the absence of detailed data. Similarly, longer duration unplanned unforeseen events scripted into a scenario were assumed to allow for crewmember sleep time. It could be assumed that, depending on the nature of the event, the crew might go to alternate sleep schedules, but the IMPRINT Force model did not allow this to be built in. Therefore, sleep was added to crewmembers during unforeseen events at the cost of work hours.

It was assumed that some activities (e.g., task management and handling maintenance events) would take from work hours, but not for other activities. Therefore, due to limitations with the IMPRINT Force model, these events were post processed and added to the scenario after models were executed. Also, because exercise was determined to be of a higher priority than work hours, it was assumed that some time lost for exercise due to unplanned events would be returned from the pool of work hours. The formula used for this was half the difference between previously calculated full Mars mission exercise and the baseline Perfect World ISS model exercise. Finally, the IMM data only accounted for quality crew time lost due to injury or illness for the afflicted crewmember. It did not account for time spent by other crewmembers attending to the injury or illness and is therefore conservative overall in its impact.

In developing the schedules for the model, the assessment team made assumptions on Mars transit operations. There are limitations on these assumptions on tasking that will be added to a Mars crew (i.e., the R&R maintenance and repair paradigm on ISS that relies on resupply will not be feasible on a Mars mission) and on tasking that may not be required for a Mars transit (i.e., the assessment team did not remove cargo vehicle operations from ISS work hours). As the Agency more fully defines the Mars transit operations, these assumptions and limitations on tasking can be updated.


#### **7.2.4.4 Results and Discussion**

The manageability of tasks is considered within the human performance dimension of the trade space framework for evaluating crew size. The Mars Transit Crew model allows for an analysis

of manageability of tasks, specifically crew utilization and manpower requirements, given the impact of unplanned, or different anticipated tasking, on a crew’s ability to perform work during a 9-month Mars transit mission. The assessment team built a series of models for comparison of manpower requirements.

#### 7.2.4.4.1 Perfect ISS World Scenario Model

The first step in the comparative analysis of IMPRINT Force model results was to build a baseline model consisting only of a four-person crew performing planned activities on schedules, execute that model for 9 months, and obtain the summative model results of what activities were performed by each crewmember. Figure 132 shows an example of raw data from this model execution.

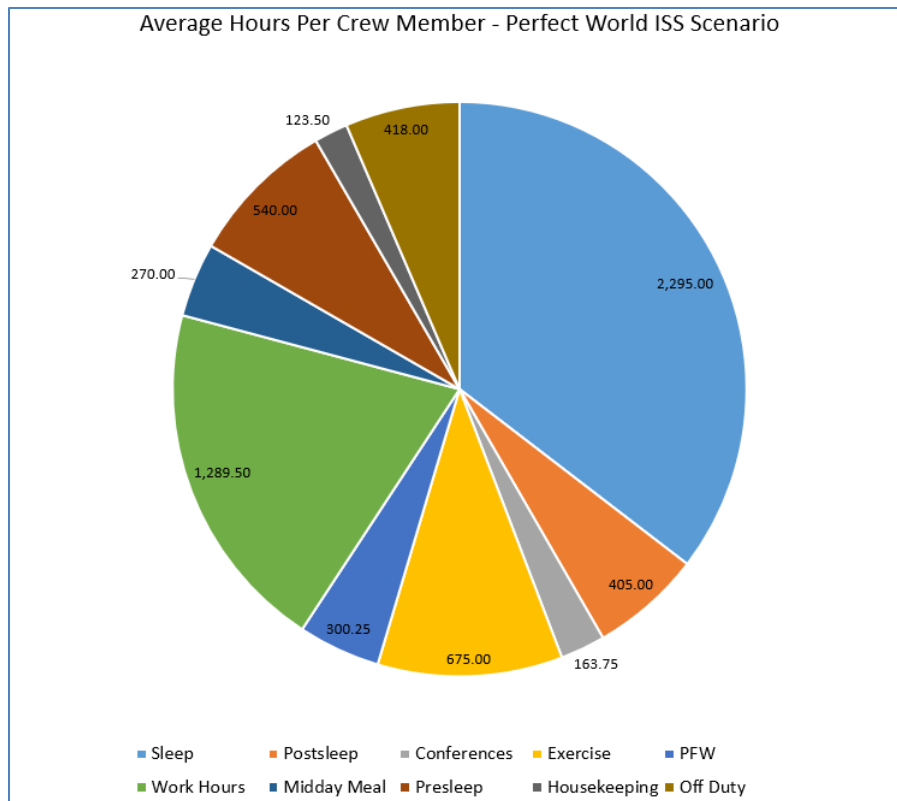
 <b>IMPRINT Forces Model Report</b> <b>Time Total By Resource</b>			
<b>Analysis:</b> MarsTransitModel_NineMonthUpdatedSkedAllCombosV3			
<b>Force Unit:</b> 01MTVWeeklyScheduleUpdatedBaselineNoUnplanned			
<b>Initial RNS:</b> 1			
<b>Date:</b> 14-Dec-23			
<b>Note:</b> Resource refers to Jobs and Assets			
			Activity Time (Hours)
Resource	Schedule	Activity	Average
Crew 1	Crew1Schedule	DPC	97.0000
		eDPC	9.5000
		Evening PFW	203.2500
		Exercise	675.0000
		FD Crew Conference	19.0000
		Housekeeping	114.0000
		Midday Meal	270.0000
		Morning PFW	97.0000
		Off Duty	418.0000
		PFC	9.5000
		PMC	9.7500
		Postsleep	405.0000
		Presleep	540.0000
		Safing	19.0000
		Sleep	2,295.0000
		Work Hours	1,280.0000
	WPC	19.0000	

**Figure 132. Crew Activity Report from IMPRINT**

It became apparent that charting all crew schedule delineated activities for comparative purposes was not necessary, nor would it be useful as many ‘slivers’ were created in pie charts summarizing activities. Therefore, some activities were grouped, as follows:

- All **Conferences** were grouped together (Daily Planning Conference (DPC), evening DPC (eDPC), Flight Director Crew Conference, Weekly Planning Conference (WPC).
- Prepare for Work (Morning and Evening **PFW**) activities were combined.
- Safing (putting systems into a safe configuration for housekeeping) was combined with **Housekeeping**.

After combining activities, the average crew activity hours, for the 270-day Perfect World ISS scenario were summarized and compared using the pie chart shown in Figure 133.



**Figure 133. Average Crew Hours - Perfect World ISS Scenario**

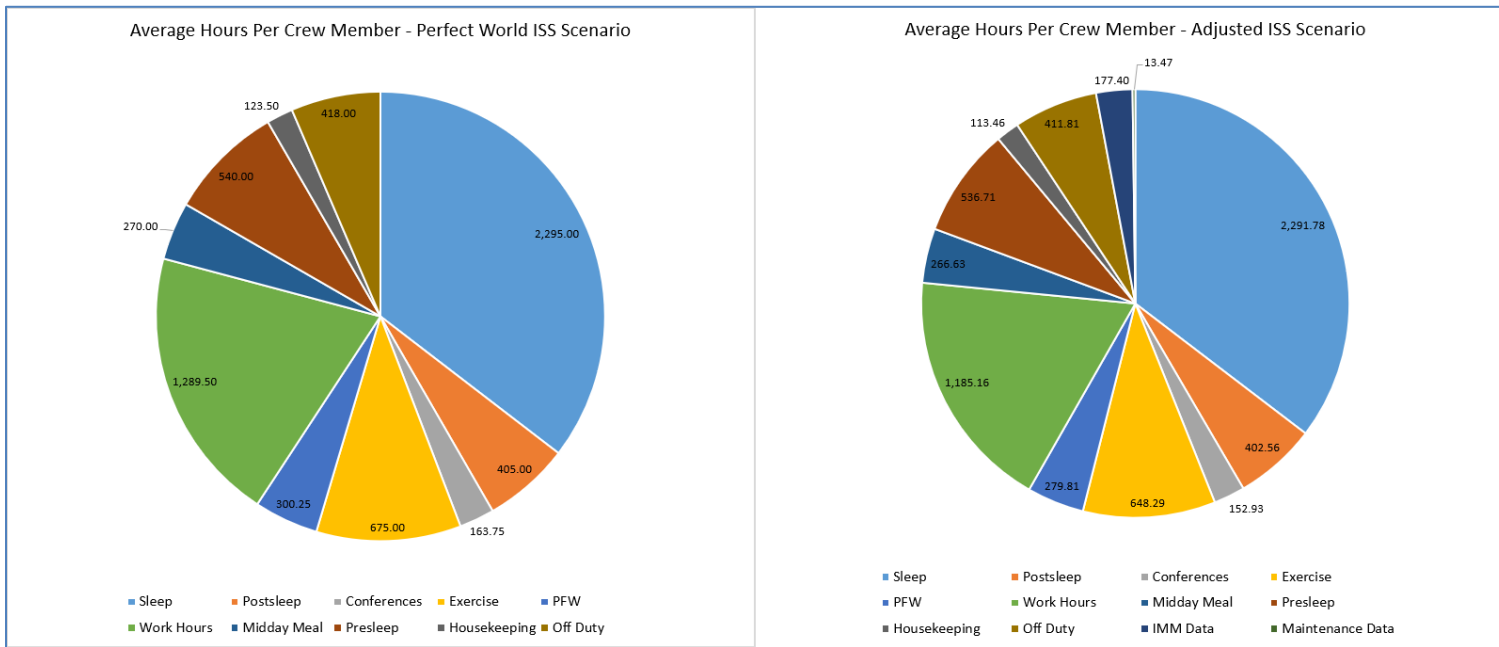
Of particular interest for comparisons with other scenarios are the work hours utilized by each crewmember of the four-person crew during the 9-month period. Based on a 5-day work week, and not inclusive of PFW, they are significant the second largest bucket of activity behind sleep.

#### 7.2.4.4.2 Adjusted ISS Scenario Model

Although an ISS crew can rely on real-time MCC support, they may experience off-nominal events that take from their ability to perform normal work. Based on data analyzed per the previous section of this report, the two unplanned activities that were added to the “Perfect ISS World Baseline” model were possible medical events as derived from the IMM data, and possible maintenance events derived from maintenance data. Only the average for these events was utilized for the Adjusted ISS Scenario Model, as it became the baseline for possible Mars mission comparisons, which included different possible levels of occurrence.

The pie chart of different predicted activities for the Adjusted ISS Scenario Model is shown in Figure 134 and compared to the ISS Perfect World Scenario results. Of particular note, the IMM data indicated that possible illnesses and injuries will have a larger impact on the crew’s ability to do work than maintenance data. Overall, there is a predicted 8% decrease in work hours. Sleep was kept constant, but there was a 4% reduction in exercise.





**Figure 134. Average Crew Hours - Adjusted ISS Scenario compared to Perfect World ISS Scenario**

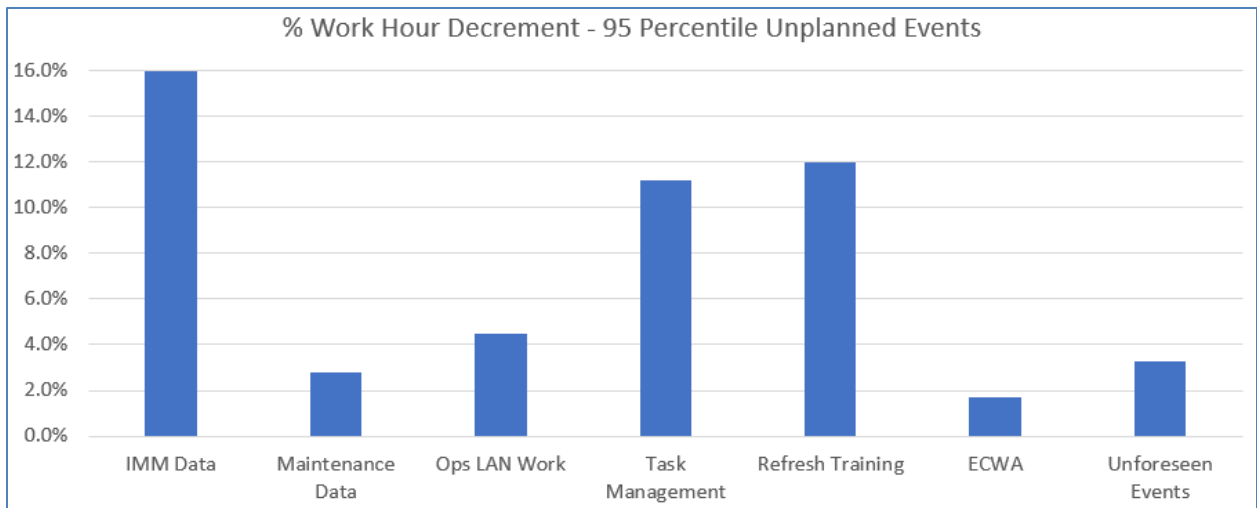
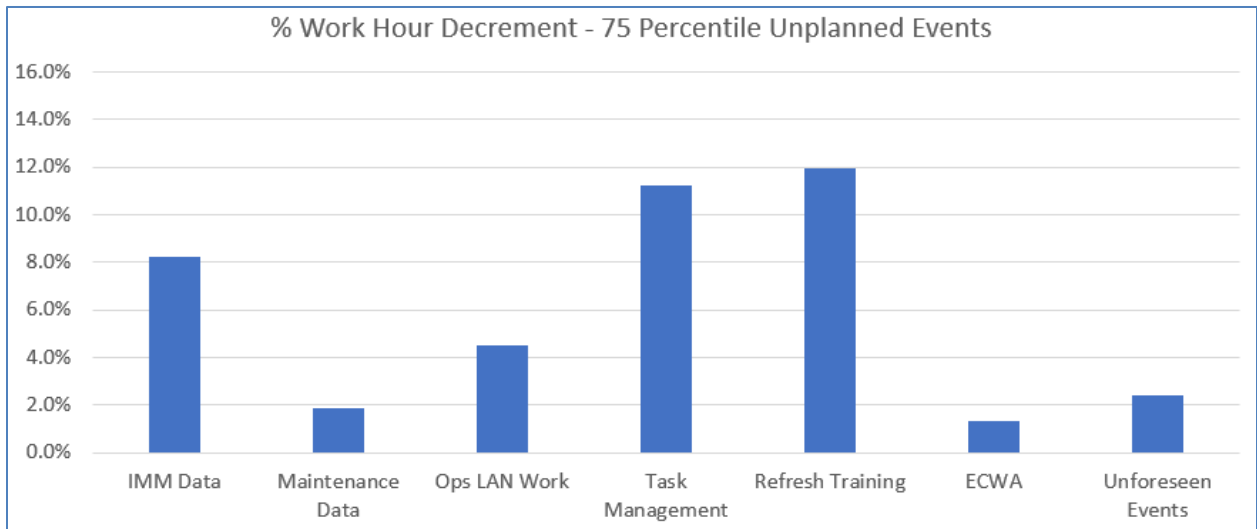
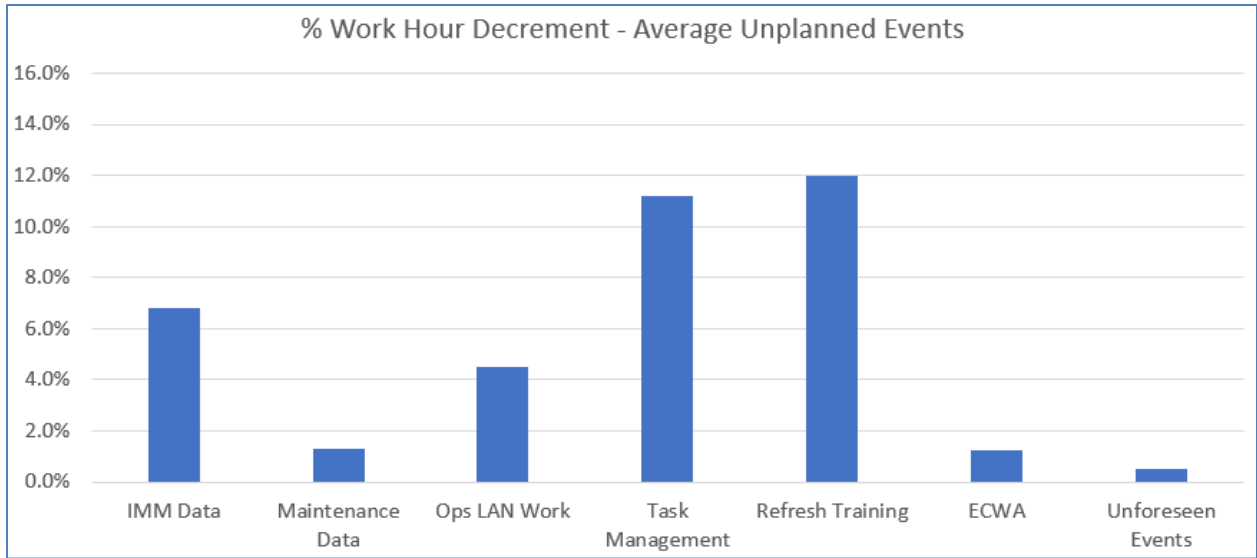
#### **7.2.4.4.3 Full Mars Scenario Model Results and Discussion**

To build a predictive model of a possible Mars transit scenario, several other tasks and unplanned events were added to the Adjusted ISS Scenario in addition to the IMM and maintenance data. First, tasking for one crewmember was added to their regular schedule to perform Ops LAN work which would normally be performed by the ground for the ISS. Next, unplanned events were added to the model to deal with ECWA, and to respond to unforeseen events. Task management activities were added to the post-processing of model results to account for more activity (i.e., calendar or workweek daily) that would need to be performed by the crew, and a conservative 25% time penalty on maintenance tasks.

The updated Mars mission model scenario was executed under three conditions: average occurrences of each unplanned event, 75% confidence level occurrences of each unplanned event, and 95% confidence level occurrences of each unplanned event. Results were compared to the Perfect ISS World Baseline model and the Adjusted ISS Scenario model for the average and 75% confidence level occurrences with the 95% confidence level percentile case not being presented as noted above. To additionally identify relative impacts of each newly introduced model attribute, including those introduced for the Adjusted and the more realistic ISS model, on average crew work hours for a four-person crew, each component model was executed individually. The resultant bar charts in Figure 135 show how each added task impacts work hours for different occurrence levels of the unplanned events.

The first two columns on each of these charts, the IMM Data and Maintenance Data unplanned events, are applicable to the Adjusted ISS Scenario at the average level. The next three columns, Ops LAN Work, Task Management, and Refresh Training, all represent Mars scenario unique tasking due to separation of the ground and are constant, which were not extended based on statistical percentiles. Finally, the last two columns of the ECWA and the Unforeseen Events are unplanned activities that will require more crew time due to ground separation and are varied statistically similar to the IMM data and maintenance data.

Of the four unplanned events (i.e., IMM Data, Maintenance Data, ECWA, and Unforeseen Events), the IMM Data is the most impactful. However, at average and 75% confidence level of unplanned events, the Task Management and Refresh Training Mars-unique tasking are more impactful than the IMM Data. Of note, the IMM data statistical outliers have the potential to be the most debilitating to the crew, as shown in the 95% confidence level occurrence chart.



**Figure 135. Percentage of Work Hour Decrements for Added Mars Scenario Tasks**

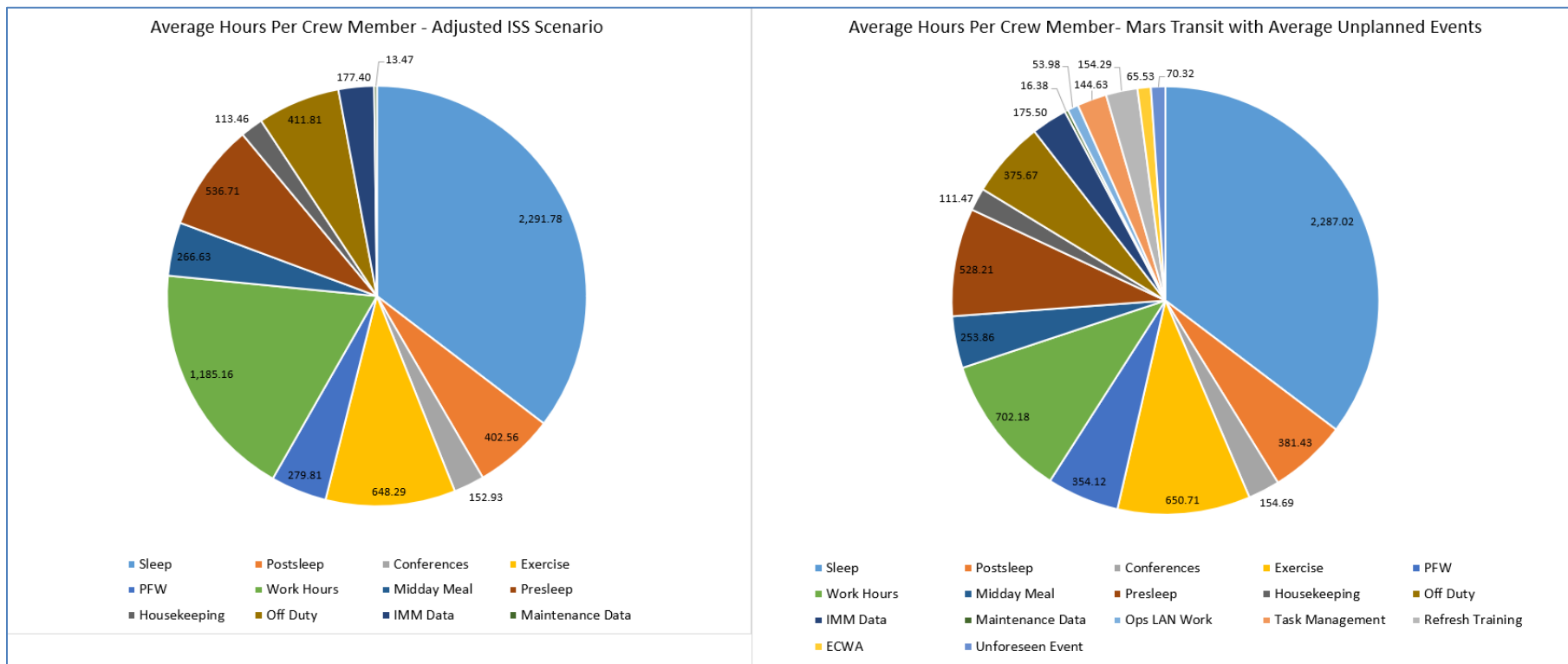
Next, each full four-person crew model was executed for 9 months and results were post processed to update sleep hours, exercise, work hours, and other time impacted by hour “give backs” that needed to be made, keeping sleep and exercise as high priority planned activities. For the Average Unplanned Events Mars transit scenario, updated average hours per crewmember spent on different activities is shown in Figure 136 and compared to the Adjusted ISS Scenario model. Sleep hours and exercise were minimally impacted due to post-processing assumptions. However, work hours were significantly impacted as reduced 41% from the Adjusted ISS Scenario.

Similar results are shown in Figure 137 for the 75% Confidence Level Unplanned Event Mars transit scenario as compared to the Adjusted ISS Scenario. For this scenario, Work Hours were reduced by approximately 50% from the Adjusted ISS Scenario.

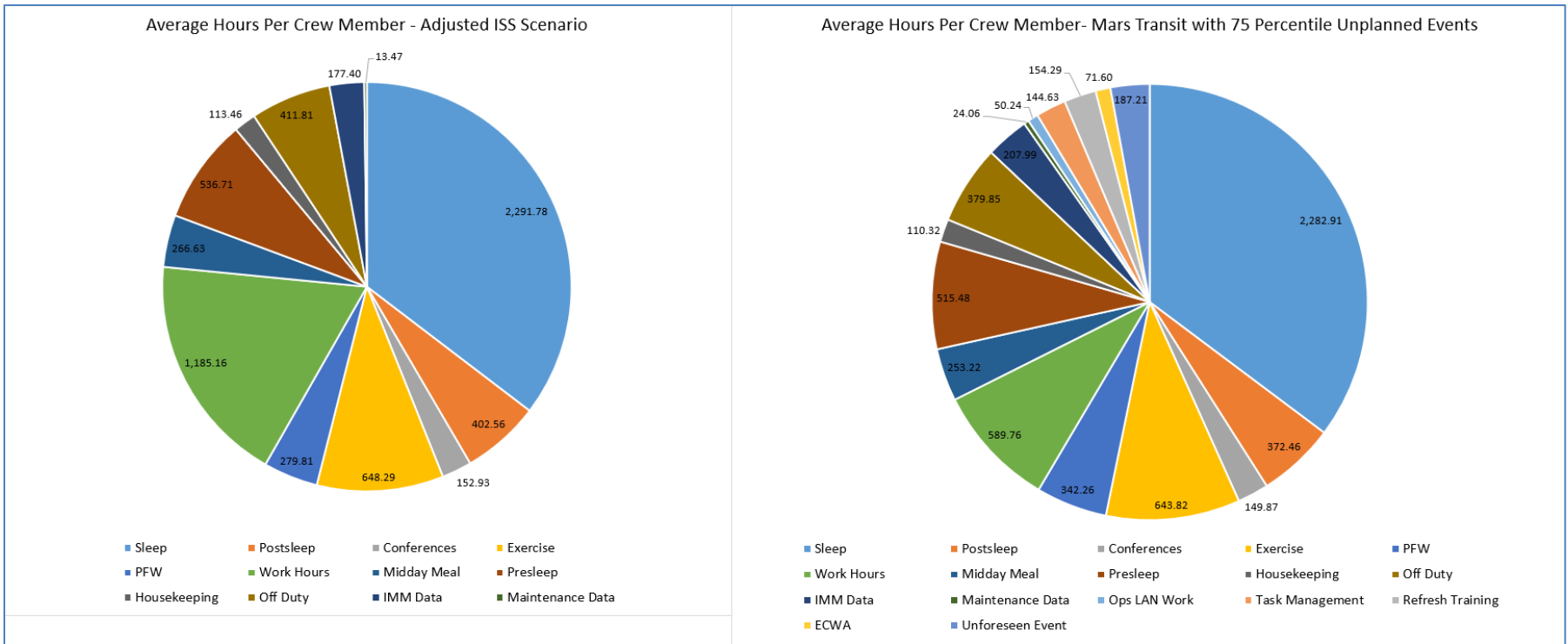
**F-12.** IMPRINT modeling predicts that average rates for unplanned events will reduce the available time for a four-person Mars crew to perform work by 41% compared with a four-person ISS crew.

**F-13.** IMPRINT modeling predicts that 75% confidence level rates for all unplanned events will reduce the available time for a four-person Mars crew to perform work by 50% compared with a four-person ISS crew.

The average and 75% confidence level cases were chosen for additional comparisons and subsequent manpower analyses because they represent a reasonable range of potential events, given some of the conservative assumptions made (e.g., no crew assistance added for IMM Data events) and other potential unknowns of a Mars mission. The overall 95% confidence level percentile case was not carried forward for analysis, as noted above.



**Figure 136. Average Crew Hours - Adjusted ISS Scenario compared to Mars Transit with Average Unplanned Events**



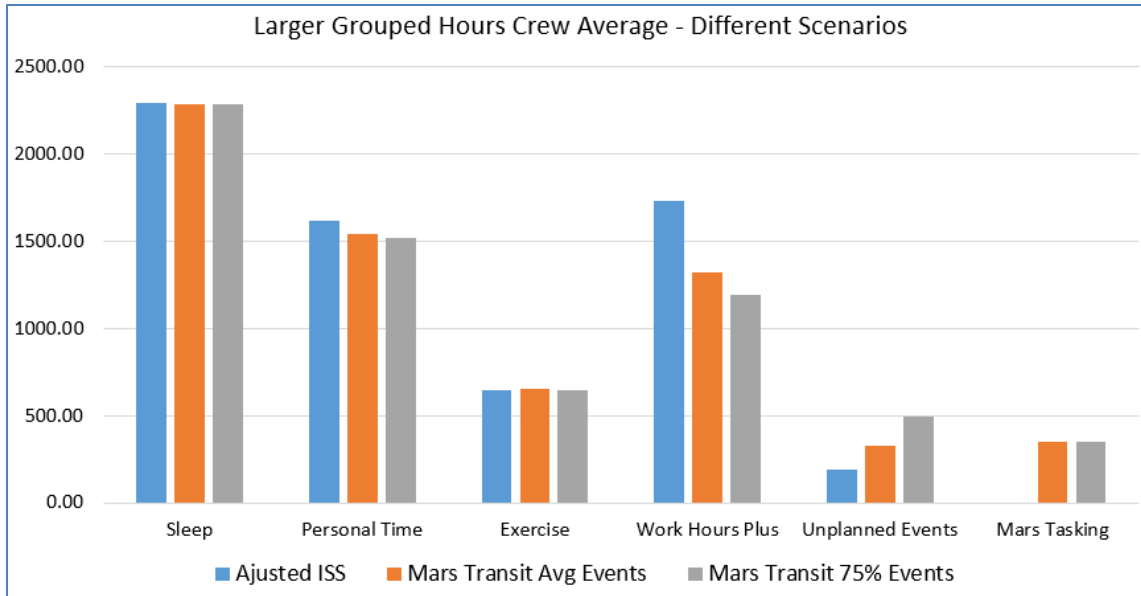
**Figure 137. Average Crew Hours - Adjusted ISS Scenario compared to Mars Transit with 75 Percentile Unplanned Events**

To understand how different types of activities were being impacted by the Mars specific unplanned events and tasks, tasks were grouped into higher categories in addition to the original groupings for meetings and preparing for work. Sleep and exercise were retained as separate categories, but other “Personal Time” was grouped to include categories as shown in Figure 138. Similarly, work hours were expanded to include PFW, conferences, and housekeeping, and unplanned events were grouped as were Mars Tasking activities, all as shown per the color coding in Figure 138.

Mars Transit Average			
Sleep	2287.02	Sleep	2287.02
Postsleep	381.43	Personal Time	1539.18
Conferences	154.69	Exercise	650.71
Exercise	650.71	Work Hours Plus	1322.45
PFW	354.12	Unplanned Events	327.74
Work Hours	702.18	Mars Tasking	352.91
Midday Meal	253.86		
Presleep	528.21		
Housekeeping	111.47		
Off Duty	375.67		
IMM Data	175.50		
Maintenance Data	16.38		
Ops LAN Work	53.98		
Task Management	144.63		
Refresh Training	154.29		
ECWA	65.53		
Unforeseen Event	70.32		

**Figure 138. Grouped Tasking for Additional Analysis**

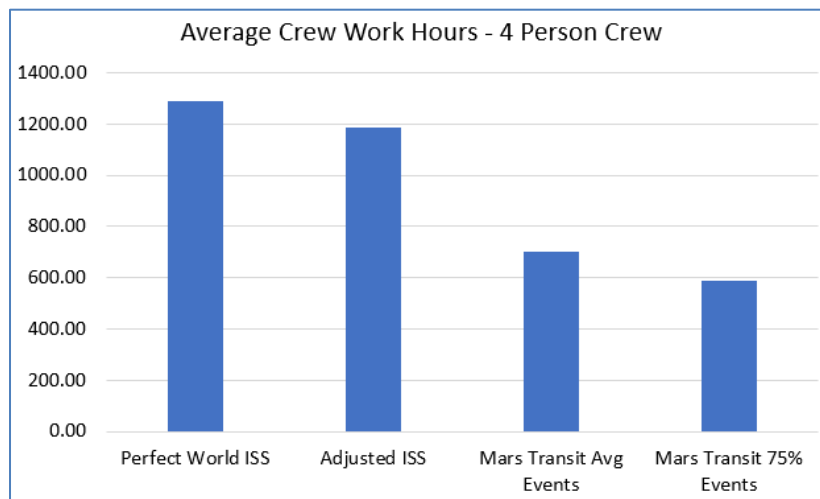
Next, these groupings were compared across the three four-person crew scenarios being examined (i.e., the Adjusted ISS, the Mars Transit with Average Unplanned Events, and the Mars Transit with 75% Confidence Level Unplanned Events scenarios). As Figure 139 shows, sleep and exercise were kept constant between the different scenarios. Some other personal time was lost, but to a lesser degree than work hours and activity associated with work (i.e., the unplanned activities and Mars Tasking took most hours from work).



**Figure 139. Comparison of Grouped Crew Average Hours for Different Scenarios**

#### 7.2.4.4.4 Manpower Analysis Based on Work Hour Results

In the future, Mars mission manpower requirements will be based on numerous considerations, including primary mission objectives, human health risks and countermeasures, and required expertise within the crew. However, manpower requirements may be based on the crew’s predicted ability to perform certain tasks within the time frame of a mission. The IMPRINT Force model allows an analyst to perform this type of analysis. For this model, it is assumed work hours in the crew’s daily schedule include critical tasks required of the crew to accomplish a successful mission. For the four scenarios modeled inclusive of the Perfect World ISS scenario without unplanned events, Figure 140 shows the average crew work hours predicted for a four-person crew.



**Figure 140. Average Crew Work Hours for Different Scenarios**

For the purposes of this preliminary manpower analysis, it was assumed that a Mars crew would need to be able to accomplish the same number of work hours as a four-person crew on an ISS mission that includes some unplanned events, or the Adjusted ISS Scenario. Comparison of the



four-person crew average work hours per crewmember for the Adjusted ISS Scenario with average work hours for the Mars Transit Average Events and with Mars Transit with 75% Confidence Level Events, per Table 76, serves as a baseline for a manpower analysis.

**Table 76. Average Crew Work Hours**

	Average Crew Work Hours
Adjusted ISS Scenario	1185.16
Mars Transit Avg Events	701.73
Mars Transit 75% Events	589.76

To consider how many additional Mars crewmembers would be needed to accomplish the same number of work hours as a four-person ISS crew based on the Adjusted ISS Scenario model, the assessment team had to determine the number of work hours each additional crewmember would have available. Some events and tasking will be levied on each additional crewmember. For example, the IMM data indicated that potential injuries and illnesses were linear in their occurrences as more crewmembers were added. Also, some tasks are performed by all crewmembers (e.g., emergency response). Unplanned events and Mars tasking that will not provide additional crewmembers with added available hours for work include:

- IMM Data
- Task Management (performed by all crewmembers)
- Unforeseen Events
- Refresher Training

Other events and tasking are levied on a subset of the crew, so with additional crewmembers' capacity for additional work hours can be added to the average hours shown in Table 76. The tasks associated with additional capacity hours for work are shown in Table 77.

**Table 77. Extra Work Capacity for Additional Crewmembers**

Unplanned Event/Mars Task	Hours Avg Case	Hours 75% Case
Task Management (performed by one crewmember)	22.50	22.50
Ops LAN Work	53.98	50.24
Warning, Caution, and Advisory Events	32.77	35.80
Maintenance	16.83	24.06
<b>Total Extra Capacity vs Average Crew Capacity in each case</b>	<b>126.08</b>	<b>132.60</b>

For a four-person crew, the Adjusted ISS Scenario four-person crew can accomplish 4 x 1,185.16 hours of work, or 4,740.64 total hours. This is the target for a Mars crew. A simple formula to compute the “ideal” crew number based on these work hours is:

$$N_{\text{ideal}} = 4 + (4,740.64 - 4 * \text{AvgMarsWorkHours}) / (\text{AvgMarsWorkHours} + \text{AddedCapacity})$$

Based on this formula, the ideal crew sizes to accomplish the same amount of work as the Adjusted ISS Scenario are **6.34** crewmembers for the Mars transit scenario with Average Unplanned Events and **7.30** crewmembers for the Mars transit scenario with 75% Confidence Level Unplanned Events.

**F-14.** IMPRINT modeling predicts that more than six crewmembers will be needed to achieve the same number of work hours on a Mars transit as on a four-person ISS mission given average rates for all unplanned events.

**F-15.** IMPRINT modeling predicts that more than seven crewmembers will be needed to achieve the same number of work hours on a Mars transit as on a four-person ISS mission given 75% confidence level rates for all unplanned events.

#### **7.2.4.5 Conclusions**

The Mars Transit Crew model is designed to consider the manpower requirements for a mission to Mars given inputs on crew tasking and unplanned events. Without real-time support from MCC, tasks will need to be shifted from MCC to the crew or onboard systems due to communication delay/blackout. Additionally, unplanned events (e.g., medical events or unforeseen failures) will impact the time available for the crew to complete mission work tasks. The IMPRINT Force model is an effective tool to show the available work hours in a crew of a given size using historical and analog data to model Mars mission data.

##### *Future Models: Trades in Mission Design Parameters*

The Mars Transit Crew model built by the assessment team demonstrates a methodology for a systematic, repeatable process for evaluating crew size based on manpower requirements. In discussing the model inputs and results with SMEs, there are trades in mission design parameters, including task automation that could be considered in working to reduce the manpower requirements for missions to Mars. For example, the flight controllers interviewed acknowledged that automation of tasks (e.g., safing) could be accomplished resulting in less work hours assigned to the Mars crew.

This model assumes continual time-delayed communication throughout the mission, and therefore does not address task shifting due to crew due to planned windows of communication rather than continual time-delayed communication and due to a communication blackout. Further analysis is needed to determine the impact of sporadic communication or a communication blackout on crew size.

As the Agency works to more fully define Mars transit operations and develops an understanding of critical technologies for future vehicles, additional models can be built to show the impacts of these to crew workload and manpower requirements.

## 7.2.5 Personnel, Expertise, and Training Model

### UNFORESEEN FAILURE SCENARIO ON TRANSIT TO MARS

*On the transit to Mars, an unforeseen failure in the thermal control system occurs with the possibility of cascading failures if vehicle equipment overheats. The procedures do not address the specific failure, so the crewmember assigned as the thermal control system lead quickly diagnoses the lost functionality and works with the electrical power system lead to make critical decisions to safely power down redundant systems. At the same time, the payloads specialists ensure all experiments are smoothly but quickly powered down. The crew works together to reroute power to ensure critical systems remain operational despite the failure. With a communication relay between Earth and Mars preventing a communication blackout, twenty minutes later the ground receives the first telemetry indicating that there has been a major system malfunction of the Transit Habitat. The flight director calls in a team to develop a plan for diagnostic troubleshooting to determine the root cause failure and then to create a repair plan. As the crew waits for detailed instructions from the ground on the repair plan, they review system schematics and refresh themselves on the tools and equipment that will be needed to restore full system functionality. Events including responding to an unforeseen major system malfunction with loss of crew/loss of mission consequences and short time-to-effect are considered in the development of the Personnel, Expertise, and Training model.*

#### 7.2.5.1 Purpose and Scope

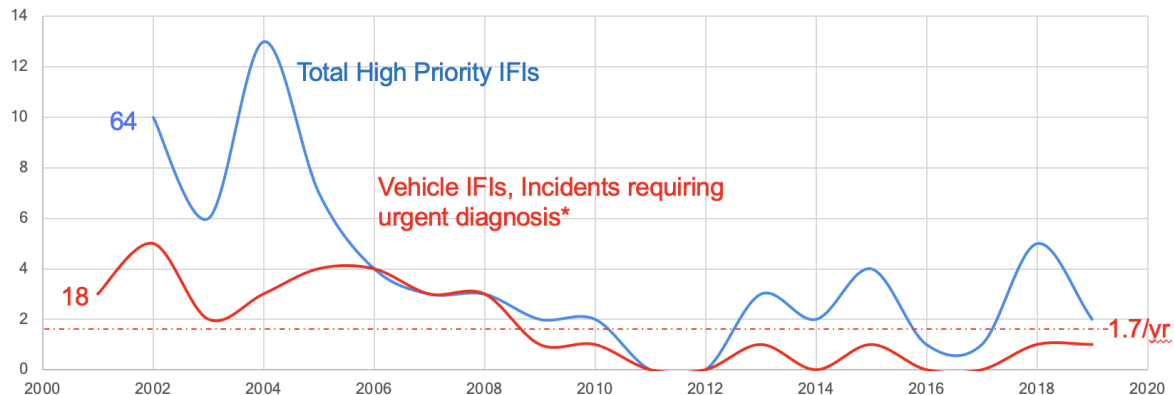
The number of crew for a mission to Mars can be informed by personnel factors, including the knowledge, skills, abilities needed to perform the necessary roles and responsibilities. These responsibilities are defined by the duties and tasks to operate, maintain, troubleshoot, and repair systems in the vehicles across the Mars mission architecture (e.g., the EPS or the C&DH), to perform vehicle operations (e.g., piloting, EVA, and robotics), and to conduct payload operations to meet NASA's scientific mission objectives. The Personnel, Expertise, and Training model is designed to quantify to some measure the trade space between the number of crew and the necessary capabilities required to successfully perform all mission tasks.

While the capability within the crew to operate, maintain, troubleshoot, and repair systems, operations, and payloads is critical for mission success, many tasks will likely be performed at a tempo that allows for communication delay/blackout exchanges with the MCC to take advantage of the expertise within the flight control team on the ground. Nonetheless, there are nominal, time-critical tasks that the crew will need to perform without the real-time support of the MCC on the ground (e.g., piloting, EVA operations, certain robotics operations, vehicle system commanding that requires real-time responses). Most critical is the real-time, onboard expertise needed to respond to unforeseen failures with potential loss of crew/loss of mission consequences and short time-to-effect.



## Current Status State of Knowledge (New Evidence)

### ISS: High Priority IFIs, Significant Incidents in Vehicle Systems Requiring Urgent Diagnosis\*



\* Those with potentially high consequence outcomes (e.g., high priority IFI) **and** significant uncertainty surrounding their origins. These issues are not known emergencies but have significant time pressure to identify causality, e.g., so that cascading or common cause failure modes can be avoided.

**Figure 141. High Priority ISS Items for Investigation**  
[ref. 38]

An analysis of ISS unforeseen failures, classified as items for investigation (IFIs), conducted by NASA’s HSIARisk team showed that IFIs requiring urgent diagnosis have occurred on average 1.74 times per year with 95% upper bound 2.32 times per year on ISS, where such IFIs are “those with potentially high consequence outcomes **and** significant uncertainty surrounding their origins. These issues are not known emergencies [i.e., for which pre-planned responses exist] but have significant time pressure to identify causality (e.g., so that cascading or common cause failure modes can be avoided)” [ref. 38] (Figure 141)). [Note, this analysis did not include IFIs associated with EVAs.] Because these failures are of unknown origin, there is not a published procedure for MCC or the crew to execute. A HSIARisk Custodian provided this analysis as evidence that there may be a similar rate of unforeseen failures requiring urgent diagnosis outside the scope of procedures on future mission to Mars given the complexity and uniqueness of spaceflight vehicles [ref. 38].

The assessment team conducted further analysis in considering the risk of unforeseen failures with loss of crew/loss of mission consequence and short time-to-effect. Using the ISS incident rate above of 2.32 IFIs/yr. and using Mars reference mission durations with crew in interplanetary space for 730, 900, or 1094 days (Table 78), the team calculated the occurrence rate of such events for the three reference missions (Table 79) [ref. 36].

**Table 78. Crewed Mars Mission Phase Durations Right [ref. 36]**

Ref. Mission	Mars Crewed Phase Duration Time (Earth days)				Inter-planetary Time and Total Crew Time Away from Earth	Total (for all crew) Mars Surface EVA Hours
	Crewed Cis Lunar Staging/ Phasing	Out-bound Transit	Mars Surface Stay	Mars Orbit Loiter + Earth Return Transit Earth		
	<i>Microgravity</i>	<i>Micro-gravity</i>	<i>0.376 g</i>	<i>Microgravity</i>		
Point of Departure (PoD 2020)	90-day initial Earth launch window + 40 days after return (4 crew)	305 days (all 4 crew)	30 days (only 2 of 4 crew)	50-day Mars orbit loiter (2 of 4 crew on surface for 30 of 50 days) then 375 days return transit (all 4 crew)	730 days inter-planetary. Total at least 771 but no more than 860 Days	Up to 320 crew-hours <sup>2</sup> (among 2 crew)
Alternative Short Stay (2020)	90-day initial Earth launch window + 40 days after return (4 crew)	Up to 200 days (all 4 crew)	30 days (only 2 of 4 crew)	Up to 500-day Mars orbit loiter (2 of 4 crew on surface for 30 of 500 days) then Up to 200 days return transit (all 4 crew)	Up to 900 days inter-planetary. Total no more than 1030 Days	Up to 320 crew-hours (among 2 crew)
Basis of Comparison (BoC 2019)	90-day initial Earth launch window + 40 days after return (4 crew)	429 days (4 crew)	Up to 300 days (all 4 crew)	365 days (4 crew)	<sup>3</sup> 1094 days inter-planetary. Total no more than 1,224 Days	No more than 3000 crew-hours <sup>4</sup> (among 4 crew)

**Table 79. Occurrence Rate for Unforeseen Failures**

Ref. Mission	Mission Duration (days in interplanetary time)	Expected Number Unforeseen Failures with Potential Loss of Crew/Loss of Mission Consequences and Short Time-to-Effect
Point of Departure (POD 2020)	730	=2.32/365 x 730 =4.64
Alternative Short Stay (2020)	900	=2.32/365 x 900 =5.72
Basis of Comparison (BoC 2019)	1094	=2.32/365 x 1094 =6.95

With the total count of IFIs during 19 years (2001 to 2019) that needed urgent diagnosis and annual count of such IFI data from Figure 141, several statistical analyses were performed including Poisson Distribution fitting, Reliability Growth Modeling and Normal distribution approximation for assessing upper bound of the annual rate of IFIs. The team determined the Poisson distribution method, which is considered to be relatively simple and straightforward and provides a reasonable upper bound, to be an appropriate method for this assessment.

The assessment team used a Poisson distribution to estimate the probability of the number of events given an upper bound expected number of events (event rate,  $\lambda$ ) with 95% confidence during a fixed time duration (one year).

$$Prob(X = k) = \frac{\lambda^k e^{-\lambda}}{k!} \quad (1)$$

In Eq. (1),  $k$  is the number of occurrences ( $k=0,1,2,\dots$ ),  $\lambda$  is the expected number of occurrences during a fixed time duration (one year for this application). From Figure 141, the best estimate ( $\hat{\lambda}$ ) and 95% upper bound of  $\lambda$  ( $\hat{\lambda}_{95\%}$ ) are given by the equation (2) and (3) respectively.  $\hat{\lambda} = \text{Average Number of IfIs per year} = 33 \text{ IFIs}/19 \text{ years} = 1.74$  (2)

$$\hat{\lambda}_{95\%} = \chi_{2,df}^{-1}(0.95, 2(F + 1))/(2N) = 2.32 \quad (3)$$

In Eq.(3),  $F$  is the number of failures,  $N$  = number of the years that the data were collected (=19, Year 2001 to Year 2009),  $df$  is the degrees of freedom which = 2 ( $F+1$ ) = 2 (33+1) =68,  $\chi_{2,df}^{-1}(0.95, 2(F + 1))$  is the Chi-square percentile with 95% probability and degrees of freedom = 68.

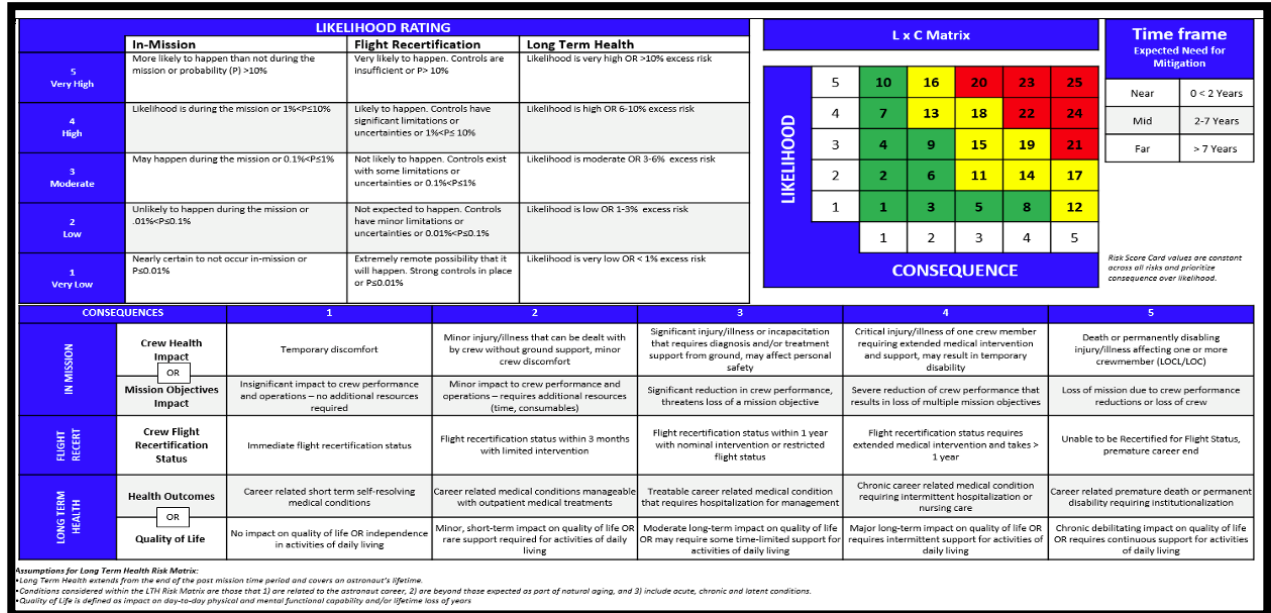
Based on the Poisson distribution formula with  $\hat{\lambda}_{95\%}$ , the probability of at least one occurrence of an unforeseen failure with potential loss of crew/loss of mission consequences and short time-to-effect during the time the crew is in interplanetary space for each of the three reference missions in Table 80 is as follows:

- For Point of Departure Mission,  
 $P(\text{at least one event}) = 1 - P(\text{zero event}) = 1 - \frac{4.64^0 e^{-4.642}}{0!} = 99.03\%$
- For Alternative Short Stay Mission,  
 $P(\text{at least one event}) = 1 - P(\text{zero event}) = 1 - \frac{5.72^0 e^{-5.72}}{0!} = 99.67\%$
- For Basis of Comparison Mission,  
 $P(\text{at least one event}) = 1 - P(\text{zero event}) = 1 - \frac{6.95^0 e^{-6.95}}{0!} = 99.90\%$

It is understood that not all unforeseen failures with potential loss of crew/loss of mission consequences and short time-to-effect result in loss of crew/loss of mission. Given the occurrence of a such an event, the probability of loss of crew/loss of mission due to that event depends on many factors including the nature of the event, the vehicle design, the infrastructure for supporting the crew response (e.g., information and intelligent decision-support systems) and, critically, the capability within the crew necessary to respond to the event. While the team cannot currently know many of these factors with certainty, the team can calculate the probability of a loss of crew/loss of mission outcome based on the crew's response to the failure. To do this, the assessment team conducted a sensitivity analysis of the relationship between a successful crew response and loss of crew/loss of mission outcome. Table 80 gives the results for cases in which the crew gave a successful response 90%, 95%, 98%, and 99.985% of the time. The likelihood of a loss of crew/loss of mission consequence for all but the most conservative of the cases is greater than 1%, which is very high (red) per the HSRB risk matrix (Figure 142). The likelihood of loss of crew/loss of mission consequences only drops below 0.1% (yellow) for a successful response rate of 99.985% (which equates to about 6,666 successes among 6,667 required crew responses).

**Table 80. Likelihood of Loss of Crew/Loss of Mission Outcomes**

Ref. Mission	Mission Duration (days)	Likelihood of Loss of Crew/Loss of Mission Outcomes for Unforeseen Failures with Potential Loss of Crew/Loss of Mission Consequences and Short Time-to-Effect Based on Successful Crew Response Rate			
		90% (9/10)	95% (19/20)	98% (49/50)	99.985% (6666/6667)
Point of Departure (POD 2020)	730	37.1 % (=1-exp(-4.64x(1-90%)))	20.7% (=1-exp(-4.64x(1-95%)))	8.9% (=1-exp(-4.64x(1-98%)))	0.07% (=1-exp(-4.64x(1-99.985%)))
Alternative Short Stay (2020)	900	43.6% (=1-exp(-5.72x(1-90%)))	24.9% (=1-exp(-5.72x(1-95%)))	10.8% (=1-exp(-5.72x(1-98%)))	0.09% (=1-exp(-5.72x(1-99.985%)))
Basis of Comparison (BoC 2019)	1094	50.1% (=1-exp(-6.95x(1-90%)))	29.4% (=1-exp(-6.95x(1-95%)))	13.0% (=1-exp(-6.95x(1-98%)))	0.1% (=1-exp(-6.95x(1-99.985%)))



**Figure 142. HSRB Risk Matrix**

To date, NASA’s human spaceflight programs have always been able to rely on the real-time expertise provided by the flight control personnel in MCC in responding to unforeseen failures [ref. 37]. During nominal ISS operations, there are approximately 80 personnel supporting real-time ISS operations (between the MCC FCR and MPSR, the, and the POIC) [refs. 33, 34]. In the event of an unforeseen failure, these teams can begin working the problem immediately. Additionally, the flight director can call in a separate team dedicated to working the problem, designated Team 4. A return to Earth within hours, or at most days, is always an option. Given the communication delay/blackout with Mars, NASA will no longer be able to rely on the immediate, real-time expertise provided by the MCC.

In their assessment of *Safe Expeditions Beyond Low Earth Orbit*, the NESCC identified the same risk and identified an approach to improve the risk posture:



“The HSIA key findings for long-duration missions beyond LEO are: 1) the likelihood of high consequence problems of uncertain origin occurring during spaceflight is high (conservatively, exceeding 50% during Mars transit) based on historical trends; 2) it is possible to reduce anomaly rates through improved reliability analysis and testing and anomaly impacts through added robustness, but such mitigations address only known failure modes and known uncertainties; 3) attempting to use the LEO operational paradigm (i.e., the current HSIA) with communication and resupply delays is high risk; and 4) a radical shift in operational paradigm, systems design, and human/system integration approaches is the only viable approach to improve the risk posture.” [ref. 37]

### **Summary**

Based on ISS experience, there is a very high likelihood of an unforeseen failures with loss of crew/loss of mission potential and short time-to-effect that could lead to actual loss of crew/loss of mission outcomes, even with a very small percentage of such events leading to loss of crew/loss of mission. Risk mitigations are necessary to ensure the success of missions to Mars. Candidate risk mitigation actions may include changes in the operational paradigm, changes in systems design, and changes in approaches to HSI. One critical component of HSI is the capability within the crew (achieved through training) needed to interact with the onboard information and intelligent decision-support systems to successfully respond to unforeseen failures.

Specifically, if unforeseen failures were to occur on a mission to Mars, it will be critical that the crew have the necessary level of expertise to accurately diagnose lost functionality, to safe vehicle systems and payloads and/or to reconfigure systems if necessary to prevent cascading failures, and to restore critical functionality without real-time support from the ground. This will require crewmembers to have “an understanding of how systems work, an understanding of the rationale behind flight rules, and critical thinking skills to make informed decisions when responding to urgent, unanticipated anomalies” [ref. 37]. Additionally, crewmembers will require expertise to support root cause diagnostic troubleshooting and formulating a repair plan in conjunction with the ground [ref. 46]. The Personnel, Expertise, and Training model is designed to provide the Agency with the capability to consider the trade space of crew size and level of expertise in the real-time environment, where the in-mission expertise is a necessary component for mitigating the HSIA risk.

**F-16.** There is a very high likelihood of unforeseen failures with potential loss of crew/loss of mission consequences and short time-to-effect on missions to Mars, based on historical trends.

#### **7.2.5.2 Methods and Procedures**

The assessment team created the Personnel, Expertise, and Training model to provide decision-makers with the information necessary to evaluate the capability of a Mars crew to meet primary mission objectives, perform time-critical tasks without real-time ground support, and respond to unforeseen failures with potential loss of crew/loss of mission consequences and short time-to-effect. While unforeseen failures may occur at any time during a Mars mission, this model assumes continual time-delayed MCC support is (i.e., enabled by the upgrades described in



Section 6.3.1). The two analyses of the model described below are not meant to indicate a minimum crew size or a recommended crew size, rather the methodology should be considered as an effective process for evaluating the capability in the crew.

The Personnel, Expertise, and Training model optimizes the balance of the training workload across a crew of a given size and outputs a flight-assigned Mars CQRM, a listing of crew capabilities/qualifications across the systems, operations, and payloads for each vehicle in the Mars mission architectures. SMEs can compare flight-assigned Mars CQRMs for different crew sizes across the dimensions of the trade space evaluation framework to determine recommendations to make to decision-makers. The details of how the assessment team built the model are described below.

### ***Mars Crew Qualifications and Responsibility Matrix***

The International Partners in the ISS Program maintain a Generic CQRM to identify the minimum crew qualifications for each area of responsibility necessary for an ISS mission [ref. 29]. The Generic CQRM is an excel table that lists responsibilities across all vehicle systems, operations, and payloads assigned to the crew and lists the multilaterally-agreed-to required numbers of qualifications for each responsibility, where a higher qualification indicates a higher level of responsibility (and thus a higher level of expertise)<sup>14</sup>. The Generic CQRM is used to “determine the amount and scope of training required for a crewmember” [ref. 46] to reach their designated qualifications. Each International Partner in the ISS Program maintains a listing of duties and tasks associated with each area of responsibility for their ISS modules or elements.

When a crew is assigned to an ISS mission, a flight-assigned CQRM is created from the Generic CQRM that identifies the qualification level for each responsibility for each crewmember for that mission. The flight-assigned CQRM is intended to be used by mission designers to ensure that crew responsibilities are “distributed as evenly as possible in terms of crewmember workload in training and on-orbit” [ref. 46]. The flight-assigned ISS CQRM is a table documented in an Excel<sup>®</sup> spreadsheet; however, there is not quantitative data embedded into it. Instead, mission designers work with their International Partners and training personnel to ensure crew assignments are evenly distributed.

The assessment team built a model that embeds quantitative data into a Mars CQRM and optimizes the balance of training hours across a crew of a given size given training constraints described below. To create a Generic Mars CQRM for the Personnel, Expertise, and Training model, the assessment team identified areas of responsibility for each vehicle in the FY22 strategic analysis cycle (SAC22) Mars mission architecture: the MPCV spacecraft, the Transit Habitat, the MDV, the Mars Rover, and the MAV. The assessment team assigned crew responsibilities applicable to each vehicle that include piloting, emergency response, activation/deactivation, inventory and stowage, vehicle system operations (C&DH including network administration, communication and tracking, environmental control and life support, electrical power, propulsion, and thermal control), structures and mechanisms, IV maintenance and repair, habitability (housekeeping, toilet, food and trash management), photo/TV, EVA

---

<sup>14</sup> Early in the ISS Program, NASA ISS Station Training Leads developed the CQRM, with flight director and Operation Planners buy in, to track training requirements and qualifications for each crewmember (personal communication, M. Reagan, 2024).

operations (extravehicular tasks and EVA coordination and suit walk back capability), crew medical response, medical operations (exercise equipment, environmental monitoring), robotics operations including EVA robotics and track and capture, and all transit and planetary surface research payloads. As the Mars surface architecture grows (i.e., planetary surface In Situ Resource Utilization (ISRU) propellant manufacturing, surface habitats), crew responsibilities will also grow and will need to be added to the Generic Mars CQRM. The assessment team built a candidate list of crew duties and tasks associated with each area of responsibility in the Generic Mars CQRM (published separately).

The assessment team created a list of Mars-mission qualifications to assign qualification levels required for each responsibility (Table 81). Many of these qualifications are similar but not identical to qualifications used for current Earth-to-orbit vehicle and ISS [ref. 46]. The assessment team created a new, Mars-unique qualification, “lead”, based on the need for a Mars crew to be able to perform nominal and time-critical tasks and more critically to have the real-time, onboard expertise to respond to unforeseen failures with potential loss of crew/loss of mission consequences and short time-to-effect without real-time ground support. (It should be noted that ISS uses the lead qualification for EV crewmembers but not for vehicle systems, other operations, or payloads. The Mars EVA lead qualification expands the responsibilities to include the EVA coordination crew responsibilities for missions to Mars currently performed for ISS EVAs by the MCC flight control team.)

**Table 81. Crew Qualifications for Missions to Mars**

Qualification	Designation	Description
<b>MPCV, Mars Descent Vehicle (MDV), and Mars Ascent Vehicle (MAV)</b>		
Commander	CDR	The commander title does not infer specific qualifications or responsibilities with respect to vehicle systems, but rather represents a chain of command with respect to the vehicle. All other crewmembers onboard work under the command of the vehicle commander.
Mission Specialist	MS	A mission specialist has the capability to support mission operations and live safely on-board the vehicle. This includes but is not limited to emergency response for each vehicle and all habitability duties for each vehicle.
Pilot	PLT	A pilot has the capability to live safely on-board the vehicle and to perform mission critical tasks including ascent/entry and docking piloting tasks and respond to off-nominal events and unforeseen failures. MDV and MAV pilots have the additional capability to perform activation/deactivation of the vehicles.
<b>Mars Transit Habitat and Mars Rover</b>		
Commander	CDR	The commander title does not infer specific qualifications or responsibilities with respect to vehicle systems, but rather represents a chain of command with respect to the vehicle. All other crewmembers onboard work under the command of the vehicle commander.

Qualification	Designation	Description
Operator	O	An operator has the capability to live safely on-board the vehicle and to respond to a warning event to safe a system, operation, or payload using published procedures. <sup>15</sup> This includes but is not limited to emergency response for each vehicle and all habitability duties for each vehicle.
Specialist	S	A specialist has the capability to perform all operator duties and has sufficient knowledge to be capable of responding to a caution event for a system, operations, or payload using published procedures.
Lead <sup>16</sup>	L	A lead has the capability to perform all specialist duties and has sufficient knowledge to be capable of working outside the scope of procedures to meet primary mission objectives and to respond to off-nominal events and unforeseen failures for a system, operations, or payload.
EV	S	An EV specialist crewmember has the capability to perform IV activities related to EVA hardware and EVA preparation both micro-gravity and surface EVAs.  An EV specialist crewmember has the capability to perform all EVA tasks and has sufficient knowledge to respond to off-nominal events during an EVA using published procedures, including performing an incapacitated crew rescue.  Additionally, an EV crewmember has the capability to support an EVA lead with real-time coordination of EV crewmembers during an EVA.
EVA	L	An EVA lead has the capability to perform all specialist duties. Additionally, a lead EVA crewmember has the capability to perform real-time coordination of EV crewmembers during an EVA and has sufficient knowledge of EVA operations to work outside the scope of procedures to meet primary mission objectives as well as to respond to off-nominal events and unforeseen failures during an EVA.
Crew Medical Officer	S	A crew medical officer is designated as a specialist and has the capability of responding to medical emergencies using onboard equipment and procedures.

<sup>15</sup> Warning events are more critical than caution events, therefore it might seem counterintuitive that operators are trained to respond to warning events and specialists to warnings and cautions. However, warnings are usually more straightforward to respond to. Responding to caution events require a more nuanced understanding of vehicle systems, and specialists are provided the additional training necessary to respond to these events.

<sup>16</sup> The assessment team used the ISS model that commanding to a system (for nominal or off-nominal operations) is assigned to the crewmember responsible for a specific system. However, maintenance and repair for all systems is a separate assigned responsibility. For example, an ECLSS Lead would be responsible for responding to off-nominal events and unforeseen failures by sending commands to the system via a crew interface (such as a laptop or tablet) but the Maintenance Lead would be responsible for performing maintenance and repair of the system.

Qualification	Designation	Description
Medical Doctor	MD	A medical doctor has the capability to perform all crew medical officer duties and is a fully licensed physician. <sup>17</sup>
Robotics	S	A robotics specialist has the capability of maneuvering surface robotic devices, maneuvering spacecraft elements and payloads, maneuvering EVA crewmembers, and performing unplanned tasks and has sufficient knowledge of robotics operations to respond off-nominal events to safe the system.

The assessment team conducted SME interviews with personnel in the Flight Operations Directorate (FOD) at JSC and from MSFC to determine the minimum crew qualifications for each area of responsibility necessary for a mission to Mars<sup>18</sup>. Based on these interviews, the assessment team created general guidelines for designating qualifications:

- Designate two crewmembers to the highest qualification for systems, operations, or payloads that may have unforeseen failures with loss of crew/loss of mission consequences with short time-to-effect to ensure the in-mission capability needed to meet primary mission objectives and respond to unforeseen failures across vehicle systems, operations, and payloads.

The detailed rationale for the number of qualifications at each level across the crew for each area of responsibility are:

- For each ascent/entry vehicle, MPCV, the MDV, and the MAV, two crewmembers are assigned as pilot (PLT) and are responsible for all systems and operations to the same level. All crewmembers require training on habitability duties and for emergency response for safe living on-board, so any crewmember not assigned as pilot (PLT) is assigned as mission specialist (MS).<sup>19</sup>
  - Rationale: Assigning two crewmembers to the highest qualification (PLT) provides redundancy in capability within the crew for time-critical mission operations including piloting the vehicle and responding to off-nominal events and unforeseen failures that may result in LOC or LOM. MDV and MAV pilots have capability to perform activation/deactivation of the vehicles without the real-time support of MCC.
- For the Transit Habitat, lead responsibilities are distributed across crewmembers to the qualification levels shown below. All crewmembers require training on habitability duties and for emergency response for safe living on-board, and up to four crewmembers are assigned as leads or operators for vehicle core systems, docking systems, and maintenance and repair to ensure leads for those systems have crewmembers with system knowledge to support if needed. The rationale for leads includes the understanding that

<sup>17</sup> As of this writing, NASA does not require a physician for a mission to Mars (NASA-STD-3001, Vol. 1, Rev. B). The previous revision of this standard used Levels of Care to structure how medical care would be provided and did require a physician for a mission to Mars. This designation is kept if the requirement is revised again in the future.

<sup>18</sup> The SMEs interviewed for this model included a crewmember, flight director, payload operations director, SPARTAN flight controller, EVA flight controller, and a Gemini flight controller.

<sup>19</sup> Transit Habitat piloting duties are included within the responsibilities for the propulsion system.

the crew must be able to meet primary mission objectives without real-time support from MCC and the crew must be able to independently recover the Transit Habitat in the event of an unforeseen failure.

- Emergency Operations – Two crewmembers are assigned as lead (L).
  - Rationale – Assigning two crewmembers to the highest qualification (L) provides redundancy in capability within the crew to orchestrate system leads and all other crewmembers to save the vehicle in the event of a system emergency (fire, rapid depressurization, toxic atmosphere). Each additional crewmember is assigned as an operator (O).
- Activation/Deactivation – Two crewmembers are assigned as specialist (S).
  - Rationale – Assigning two crewmembers as specialist (S) provides redundancy in the capability within the crew to perform activation and deactivation of vehicle systems and payloads. This assumes Transit Habitat activation/deactivation will occur in near-Earth-orbit and MCC is available for real-time support at the start of the mission, negating the need for a lead. No additional crewmembers are assigned responsibilities.
- Logistics – Each crewmember is assigned as specialist (S).
  - Rationale – Assigning all crewmembers as specialist (S) provides the capability within the crew to conduct logistical operations and troubleshooting independently from the ground, a task necessary for daily operations. For any unforeseen logistics issues crewmembers can wait on support from the ground, negating the need for a lead. One specialist is assigned as loadmaster, trained for any specialist logistics tasks, and assumes MCC is available for real-time support at the start of the mission.
- Vehicle Core System – Two crewmembers are assigned as lead (L) for each system (CDH with LAN, communication and tracking (C&T), ECLSS, EPS, MCS, propulsion (Prop), TCS).
  - Rationale – Assigning two crewmembers to the highest qualification (L) provides redundancy in capability within the crew in maintaining or reestablishing access to critical system information needed to respond unforeseen failures and capability in critical mission operations, including responding to unforeseen failures that may lead to loss of crew/loss of mission scenarios with short time-to-effect. Two additional crewmembers are assigned as operators (O) to achieve mission objectives.
- Structures and Mechanisms - Two crewmembers are assigned as lead (L) for docking systems.
  - Rationale – Assigning two crewmembers to the highest qualification (L) provides redundancy in capability within the crew for critical mission operations, including responding to unforeseen failures that may lead to loss of crew/loss of mission scenarios with short time-to-effect. Two additional crewmembers are assigned as operators (O) to achieve mission objectives.

- Maintenance and Repair - Two crewmembers are assigned as lead (L) for IV maintenance and repair.
  - Rationale – Assigning two crewmembers to the highest qualification (L) provides redundancy in capability within the crew for critical mission operations, including responding to unforeseen failures that may lead to loss of crew/loss of mission scenarios with short time-to-effect. Two additional crewmembers are assigned as operators (O) to achieve mission objectives.
- Habitability and Photo/TV – Each crewmember is assigned as specialist (S).
  - Rationale – Assigning each crewmember as specialist (S) ensures crewmembers can live safely on-board the vehicle and perform standard daily crew operations (housekeeping, toilet, food, and trash management) and photo/TV duties and respond to off-nominal events using procedures. For any unforeseen failures of habitability systems or photo/TV, crewmembers can wait on support from the ground, negating the need for leads.
- EVA – For a crew of up to and including four, each crewmember is assigned lead (L) for EVA.
  - Rationale – Assigning four crewmembers as EVA leads (L) provides redundancy in EVA pairs for critical mission EVA operations, including the capability within the crew in providing real-time flight director EVA coordination with the capability to respond to unforeseen failures with short time-to-effect that may lead to loss of crew/loss of mission scenarios.<sup>20</sup>
- Crew Medical Officer – At least two crewmembers are assigned crew medical officer specialist (S).
  - Rationale – NASA-STD-3001 requires at least two crew trained as crew medical officers per vehicle [ref. 47]. With the potential for a split crew with two to the surface, a total of four crew are required.
- Medical Operations (including exercise countermeasures and environmental monitoring) – Each crewmember is assigned as operator (O).
  - Rationale – Assigning each crewmember as operator (O) on medical operations ensures crewmembers can safely live on-board and maintain crew health and welfare and respond to off-nominal events using procedures. Any unforeseen failures of medical operations equipment can wait on support from the ground.
- Robotics Operations – Two crewmembers are assigned as specialist (S).

---

<sup>20</sup> The assessment team assumed the microgravity and surface suits will be the same so that crew assigned EVA for the Rover would also be EVA qualified for the Transit Habitat.

- Rationale – Assigning two crewmembers as specialist (S) provides redundancy in robotics operations.<sup>21</sup> Two crewmembers are assigned as track and capture specialist (S) providing redundancy in monitoring rendezvous at Mars. Crewmembers are trained to safe the robotic arm for any unforeseen failures and can wait on support from the ground, negating the need for a lead (L).
  - Payloads – One crewmember is assigned as specialist (S) for each of four scientific payload disciplines (material and physical science, biological science, botanical science, human physiology).
    - Rationale – Assigning one crewmember as specialist (S) for each scientific discipline provides capability in executing scientific research operations per procedures to meet primary mission objectives [ref. 6]. For any unforeseen payload failures crewmembers can wait on support from the ground, negating the need for a lead.
- For the Rover, lead responsibilities are distributed across crewmembers to the levels shown below. All crewmembers require training on habitability duties and for emergency response for safe living on-board, and crewmembers are assigned as leads or operators for vehicle core systems, docking systems, and maintenance and repair to ensure leads for those systems have crewmembers with system knowledge to support if needed. The rationale for leads includes the understanding that the crew must be able to meet primary mission objectives without real-time support from MCC, and the crew must be able to independently recover the Rover in the event of an unforeseen failure or transfer to the MAV or MDV.
  - Driving and Navigating – Two crewmembers are assigned as lead (L).
    - Rationale – Assigning two crewmembers to the highest qualification (L) provides redundancy in critical mission operations including driving and navigating the Rover.
  - Emergency Operations – Two crewmembers are assigned as lead (L).
    - Rationale – Assigning two crewmembers to the highest qualification (L) provides redundancy in capability in the system knowledge to orchestrate system leads and all other crewmembers to safe the vehicle in the event of a system emergency (fire, rapid depressurization, toxic atmosphere). Each additional crewmember is assigned as an operator (O).
  - Activation/Deactivation – Two crewmembers are assigned as lead (L).
    - Rationale – Assigning two crewmembers to the highest qualification (L) provides redundancy in capability for critical mission operations including activation and deactivation of vehicle systems and payloads without the real-time support of MCC. No additional crewmembers are assigned responsibilities.

---

<sup>21</sup> Based on SME recommendation that additional crewmembers could be trained in-mission if needed (personal communication with robotics SME, 2023).

- Logistics – Each crewmember is assigned as specialist (S).
  - Rationale – Assigning all crewmembers as specialist (S) provides the capability for the crew to conduct logistical operations and troubleshooting independently from the ground, a task necessary for daily operations. One specialist is assigned as loadmaster, trained for any specialist logistics tasks. For any unforeseen logistics issues crewmembers can wait on support from the ground, negating the need for a lead.<sup>22</sup>
- Vehicle Core System – Two crewmembers are assigned as lead (L) for each system (CDH w/LAN, C&T, ECLSS, EPS, MCS, Prop, TCS).
  - Rationale – Assigning two crewmembers to the highest qualification (L) provides redundancy in capability within the crew in maintaining or reestablishing access to critical system information needed to respond unforeseen failures and capability within the crew in critical mission operations, including responding to unforeseen failures that may lead to loss of crew/loss of mission scenarios with short time-to-effect. Two additional crewmembers are assigned as operators (O) to achieve mission objectives.
- Structures and Mechanisms - Two crewmembers are assigned as lead (L) for docking systems.
  - Rationale – Assigning two crewmembers to the highest qualification (L) provides redundancy in capability within the crew for critical mission operations, including responding to unforeseen failures that may lead to loss of crew/loss of mission scenarios with short time-to-effect. Two additional crewmembers are assigned as operators (O) to achieve mission objectives.
- Maintenance and Repair - Two crewmembers are assigned as lead (L) for maintenance and repair.
  - Rationale – Assigning two crewmembers to the highest qualification (L) provides redundancy in capability within the crew for critical mission operations, including responding to unforeseen failures that may lead to loss of crew/loss of mission scenarios with short time-to-effect. Two additional crewmembers are assigned as operators (O) to achieve mission objectives.
- Habitability and Photo/TV – Each crewmember is assigned as specialist (S).
  - Rationale – Assigning each crewmember as specialist (S) ensures they can live safely on-board and perform standard daily crew operations (housekeeping, toilet, food and trash management) and photo/TV duties and respond to off-nominal events using procedures. For any unforeseen

---

<sup>22</sup> At the time of this report, the Artemis Program is considering trades in logistics capabilities. The trades include large logistic carriers that require cranes to maneuver cargo and/or EVAs to transfer cargo. Final decision on Mars logistics capabilities and their impact on primary mission objectives may drive the need for a Mars logistics lead.



failures of habitability systems or photo/TV crewmembers can wait on support from the ground, negating the need for leads.

- EVA – For a crew of up to and including four on the surface, each crewmember is assigned lead (L) for EVA. All additional crewmembers are assigned as suit only specialist (S).
  - Rationale – Assigning four crewmembers as EVA leads (L) provides redundancy in EVA pairs to meet primary mission objectives and for critical mission EVA operations, including the capability within the crew in providing real-time EVA coordination with the capability to respond to unforeseen failures with short time-to-effect that may lead to loss of crew/loss of mission scenarios. Assigning all additional crewmember as an EVA specialist (S) ensures all crewmembers can support an EVA rescue or perform an unpressurized transfer (walk back) to the MAV if required for Mars departure in response to an off-nominal event or unforeseen failure.
- Crew Medical Officer – At least two crewmembers are assigned crew medical officer lead (L).
  - Rationale – NASA-STD-3001 requires at least two crew trained as crew medical officers per vehicle [ref. 47]. Assigning two crewmembers as leads (L) ensures the capability within the crew necessary to respond to EVA medical emergencies on the surface. CB recommends all surface crew be trained as crew medical officer specialist (S).
- Medical Operations (including countermeasures and environmental monitoring) – Each crewmember is assigned as operator (O).
  - Rationale – Assigning each crewmember as operator (O) on medical operations ensures crewmembers can safely live on-board and maintain crew health and welfare and respond to off-nominal events using procedures. Any unforeseen failures of medical operations equipment can wait on support from the ground.
- Robotics Operations – Two crewmembers are assigned as specialist (S).
  - Rationale – Assigning two crewmembers as specialist (S) provides redundancy in robotics operations.<sup>23</sup> Crewmembers are trained to safe the robotic arm for any unforeseen failures and can wait on support from the ground, negating the need for a lead (L).
- Payloads – All EVA crewmembers are assigned as lead (L) for surface geological science.
  - Rationale – Assigning all EV crewmembers to the highest qualification (L) provides the capability in executing and troubleshooting scientific research operations to meet primary mission objectives [ref. 6].

---

<sup>23</sup> Based on SME recommendation that additional crewmembers could be trained in-mission if needed (personal communication with robotics SME, 2023).

With the information above on qualifications and responsibilities, the assessment team created a Generic Mars CQRM for the five vehicles in the SAC22 Mars mission architecture (Tables 82 through 86). The Generic Mars CQRM lists the minimum crew qualifications for each area of responsibility necessary to meet primary mission objectives, to perform time-critical operations, and respond to unforeseen failures across each vehicle.

The Generic Mars CQRM is designed to be read across each row. For example, Table 83 shows that for the C&DH system on the Transit Habitat, up to four crewmembers are required to be assigned responsibilities for the system. For a crew of four, there are two leads (L) and two operators (O) responsible for the system. If constraints, described in detail below, prevent the ability to assign two leads, then one or both leads are assigned as specialist, as indicated by the L(S). For a crew size greater than four, the dash “-” indicates that no additional crewmembers are assigned responsibilities on the system.

Although the SAC22 architecture considered for analysis in this report is a mission with a crew of four with two to the surface, the assessment team built the Generic Mars CQRM for any size crew. The first size columns of the Generic Mars CQRM show the recommended number of crewmembers and qualifications for each responsibility out of a crew up to six; the last column indicates the number of qualifications for additional crew sizes. For example, Table 85 shows that for the ECLSS system on the Mars Rover, up to four crewmembers are required to be assigned responsibilities for the system. For a crew of four, there are two leads (L) and two operators (O) responsible for the system. If constraints prevent the ability to assign two leads, then one or both leads are assigned as specialist, as indicated by the L(S). For a crew size of two (as in the SAC22 mission), there would not be any assigned operators. For a crew size greater than four, the dash “-” indicates that no additional crewmembers are assigned responsibilities on the system.

**Table 82. The Generic Mars CORM – MPCV**

Generic Mars Crew Qualification & Responsibilities Matrix (CORM) Version 1.0									
ROLES (Full Crew)	Vehicle	Orion Crew Qualification & Responsibilities							
		The first six columns indicate the recommended number of crewmembers and qualifications for each responsibility out of a crew up to six. The last column indicates the number of qualifications for additional crew sizes.							
Mission Commander / Flight Engineer	MPCV	CDR	PLT	FE	FE	FE	FE		FE
<b>SYSTEM QUALIFICATION &amp; RESPONSIBILITIES</b>									
<b>Piloting Operations</b>									
Piloting (Ascent/Rndz/Entry)	MPCV	PLT (Remain on-orbit)	PLT (Remain on-orbit)	MS	MS	MS	MS		MS
<b>Complex Operations</b>									
Emergency Operations	MPCV	PLT	PLT	MS	MS	MS	MS		MS
Activation/Deactivation	MPCV	PLT	PLT	MS	MS	MS	MS		MS
<b>Logistics (Transfer, Inventory &amp; Stowage)</b>									
Logistics (Transfer, Inventory & Stowage)   One Specialist is Loadmaster	MPCV	-	-	-	-	-	-		-
<b>Vehicle Core Systems (CDH, C&amp;T, ECLSS, EPS, MCS, Propulsion, TCS)</b>									
Vehicle Core Systems (CDH, C&T, ECLSS, EPS, MCS, TCS)	MPCV	PLT	PLT	MS	MS	MS	MS		MS
<b>Structure &amp; Mechanisms, Maintenance &amp; Repair</b>									
Structures & Mechanisms, Intravehicular Maintenance & Repair	MPCV	PLT	PLT	MS	MS	MS	MS		MS
<b>Habitability Group</b>									
Habitability (Housekeeping, WHC, Food & Trash Management)	MPCV	PLT	PLT	MS	MS	MS	MS		MS
<b>Photo/TV</b>									
Photo/TV	MPCV	-	-	-	-	-	-		-
<b>Extravehicular Activity (EVA)</b>									
EVA (EVA Operations, EVA Hardware (internal tasks), and EVA Coordination)   micro-G and Surface	MPCV	-	-	-	-	-	-		-
EV Suit Only   micro-G and Surface	MPCV	-	-	-	-	-	-		-
<b>Integrated Medical Operations</b>									
Crew Medical Officer   Medical Treatment	MPCV	PLT	PLT	MS	MS	MS	MS		MS
Medical Operations   Exercise Countermeasures, Environmental Sampling (e.g., radiation monitoring, acoustic monitoring)	MPCV	PLT	PLT	MS	MS	MS	MS		MS
<b>Robotics Operations</b>									
Robotics Operations (incl. EVA Robotics (EVR))	MPCV	-	-	-	-	-	-		-
Track & Capture	MPCV	-	-	-	-	-	-		-
<b>Payloads Group (PLG)</b>									
Payloads Group	MPCV	-	-	-	-	-	-		-

**Table 83. The Generic Mars CQRM – Transit Habitat**

		Transit Habitat Crew Qualification & Responsibilities							
ROLES (Full Crew)	Vehicle	The first six columns indicate the recommended number of crewmembers and qualifications for each responsibility out of a crew up to six. The last column indicates the number of qualifications for additional crew sizes.							
Mission Commander / Flight Engineer	Transit Habitat	CDR	FE	FE	FE	FE	FE	FE	FE
SYSTEM QUALIFICATION & RESPONSIBILITIES									
<b>Piloting Operations</b>									
Piloting (Ascent/Rndz/Entry)	Transit Habitat	-	-	-	-	-	-	-	-
<b>Complex Operations</b>									
Emergency Operations	Transit Habitat	L (O) (Remain on-orbit)	L(O) (Remain on-orbit)	O	O	O	O		O
Activation/Deactivation	Transit Habitat	S	S	-	-	-	-	-	-
<b>Logistics (Transfer, Inventory &amp; Stowage)</b>									
Logistics (Transfer, Inventory & Stowage)   One Specialist is Loadmaster	Transit Habitat	S	S	S	S	S	S		S
<b>Vehicle Core Systems (CDH, C&amp;T, ECLSS, EPS, MCS, Propulsion, TCS)</b>									
Command & Data Handling (CDH) w/LAN	Transit Habitat	L (S) (Remain on-orbit)	L(S) (Remain on-orbit)	O	O	-	-		-
Communication and Tracking (C&T)	Transit Habitat	L (S) (Remain on-orbit)	L(S) (Remain on-orbit)	O	O	-	-		-
Environmental Control & Life Support System (ECLSS) (ACS)(AR), (FDS), (WRM), (THC)	Transit Habitat	L (S) (Remain on-orbit)	L(S) (Remain on-orbit)	O	O	-	-		-
Electrical Power System (EPS)	Transit Habitat	L (S) (Remain on-orbit)	L(S) (Remain on-orbit)	O	O	-	-		-
Motion Control System (MCS)	Transit Habitat	L (S) (Remain on-orbit)	L(S) (Remain on-orbit)	O	O	-	-		-
Transit Propulsion System (Prop)	Transit Habitat	L (S) (Remain on-orbit)	L(S) (Remain on-orbit)	O	O	-	-		-
Thermal Control System (TCS)	Transit Habitat	L (S) (Remain on-orbit)	L(S) (Remain on-orbit)	O	O	-	-		-
<b>Structure &amp; Mechanisms</b>									
Structures & Mechanisms   Incl. Docking System	Transit Habitat	L (S) (MDV/MAV PLT)	L(S) (MDV/MAV PLT)	O	O	-	-		-
<b>Maintenance &amp; Repair</b>									
Intraveicular Maintenance & Repair	Transit Habitat	L (S) (Remain on-orbit)	L(S) (Remain on-orbit)	O	O	-	-		-
<b>Habitability Group</b>									
Habitability (Housekeeping, WHC, Food & Trash Management)	Transit Habitat	S	S	S	S	S	S		S
<b>Photo/TV</b>									
Photo/TV	Transit Habitat	S	S	S	S	S	S		S
<b>Extraveicular Activity (EVA)</b>									
EVA (EVA Operations, EVA Hardware (internal tasks), and EVA Coordination)   micro-G and Surface	Transit Habitat	L = EVA (Remain on-orbit)	L = EVA (Remain on-orbit)	(See Rover for add'l EVA (L=O))	(See Rover for add'l EVA (L=O))	(See Rover for add'l EVA (L=O))	(See Rover for add'l EVA (L=O))		-
EV Suit Only   micro-G and Surface	Transit Habitat	-	-	-	-	-	-		-
<b>Integrated Medical Operations</b>									
Crew Medical Officer   Medical Treatment	Transit Habitat	S (Remain on-orbit)	S (Remain on-orbit)	(See Rover for Surface CMO)	(See Rover for Surface CMO)	(See Rover for Surface CMO)	(See Rover for Surface CMO)		Reqmt for 2 per Vehicle
Medical Operations   Exercise Countermeasures, Environmental Sampling (e.g., radiation monitoring, acoustic monitoring)	Transit Habitat	O	O	O	O	O	O		O
<b>Robotics Operations</b>									
Robotics Operations (incl. EVA Robotics (EVR))	Transit Habitat	S (Remain on-orbit)	S (Remain on-orbit)	-	-	-	-		See Rover for Surface ROBO
Track & Capture   Monitor Mars Rndz	Transit Habitat	S (Same as Robotics)	S (Same as Robotics)	-	-	-	-		-
<b>Payloads Group (PLG)   NEW DESIGNATIONS FOR MARS</b>									
Material & Physical Science	Transit Habitat	S	-	-	-	-	-		-
Biological Science	Transit Habitat	S	-	-	-	-	-		-
Botanical Science	Transit Habitat	S	-	-	-	-	-		-
Human Physiology	Transit Habitat	S	-	-	-	-	-		-

The Generic Mars CQRM is designed to be read across each row. For example, for the C&DH system on the Transit Habitat, up to four crewmembers would be assigned responsibilities for the system. For a crew of four, there would be two leads (L) and two operators (O). If training constraints prevent the ability to assign two leads, then one or both of the leads is assigned as specialist, as indicated by the L(S). For a crew size greater than four, the dash “-” indicates that no additional crewmembers would be trained for responsibilities on this system.

**Table 84. The Generic Mars CQRM – Mars Descent Vehicle (MDV)**

		Mars Descent Vehicle (MDV) Crew Qualification & Responsibilities							
ROLES (Full Crew)	Vehicle	The first six columns indicate the recommended number of crewmembers and qualifications for each responsibility out of a crew up to six. The last column indicates the number of qualifications for additional crew sizes.							
Mars Commander / Flight Engineer	MDV	CDR	PLT	FE	FE	FE	FE		FE
<b>SYSTEM QUALIFICATION &amp; RESPONSIBILITIES</b>									
<b>Piloting Operations</b>									
Piloting (Ascent/Rndz/Entry)	MDV	PLT	PLT	MS	MS	MS	MS		MS
<b>Complex Operations</b>									
Emergency Operations	MDV	PLT	PLT	MS	MS	MS	MS		MS
Activation/Deactivation	MDV	PLT	PLT	MS	MS	MS	MS		MS
<b>Logistics (Transfer, Inventory &amp; Stowage)</b>									
Logistics (Transfer, Inventory & Stowage)   One Specialist is Loadmaster	MDV	-	-	-	-	-	-		-
<b>Vehicle Core Systems (CDH, C&amp;T, ECLSS, EPS, MCS, Propulsion, TCS)</b>									
Vehicle Core Systems (CDH, C&T, ECLSS, EPS, MCS, TCS)	MDV	PLT	PLT	MS	MS	MS	MS		MS
<b>Structure &amp; Mechanisms, Maintenance &amp; Repair</b>									
Structures & Mechanisms, Intravehicular Maintenance & Repair	MDV	PLT	PLT	MS	MS	MS	MS		MS
<b>Habitability Group</b>									
Habitability (Housekeeping, WHC, Food & Trash Management)	MDV	PLT	PLT	MS	MS	MS	MS		MS
<b>Photo/TV</b>									
Photo/TV	MDV	-	-	-	-	-	-		-
<b>Extravehicular Activity (EVA)</b>									
EVA (EVA Operations, EVA Hardware (internal tasks), and EVA Coordination)   micro-G and Surface	MDV	-	-	-	-	-	-		-
EV Suit Only   micro-G and Surface	MDV	-	-	-	-	-	-		-
<b>Integrated Medical Operations</b>									
Crew Medical Officer   Medical Treatment	MDV	PLT	PLT	MS	MS	MS	MS		MS
Medical Operations   Exercise Countermeasures, Environmental Sampling (e.g., radiation monitoring, acoustic monitoring)	MDV	PLT	PLT	MS	MS	MS	MS		MS
<b>Robotics Operations</b>									
Robotics Operations (incl. EVA Robotics (EVR))	MDV	-	-	-	-	-	-		-
Track & Capture	MDV	-	-	-	-	-	-		-
<b>Payloads Group (PLG)</b>									
Payloads Group	MDV	-	-	-	-	-	-		-

**Table 85. The Generic Mars CQRM – Mars Rover**

		Mars Rover Crew Qualification & Responsibilities							
ROLES (Full Crew)	Vehicle	The first six columns indicate the recommended number of crewmembers and qualifications for each responsibility out of a crew up to six. The last column indicates the number of qualifications for additional crew sizes.							
Mars Commander / Flight Engineer	Rover	CDR	FE	FE	FE	FE	FE		FE
<b>SYSTEM QUALIFICATION &amp; RESPONSIBILITIES</b>									
<b>Driving &amp; Navigating Operations</b>									
Driving & Navigating	Rover	L(S)	L(S)	-	-	-	-		-
<b>Complex Operations</b>									
Emergency Operations	Rover	L(O)	L(O)	O	O	O	O		O
Activation/Deactivation (Rover and External Equipment)	Rover	L(S)	L(S)	-	-	-	-		-
<b>Logistics (Transfer, Inventory &amp; Stowage)</b>									
Logistics (Transfer, Inventory & Stowage)   One Specialist is Loadmaster	Rover	S	S	S	S	S	S		S
<b>Vehicle Core Systems (CDH, C&amp;T, ECLSS, EPS, MCS, ITCS, ETCS)</b>									
Vehicle Core Systems (CDH w/LAN, C&T, EPS, Prop, TCS) - ECLSS	Rover	L(S)	L(S)	O	O	-	-		-
Vehicle Core Systems (ECLSS)	Rover	L(S)	L(S)	O	O	-	-		-
<b>Structure &amp; Mechanisms</b>									
Structures & Mechanisms   Incl. Docking System	Rover	L(S)	L(S)	O	O	-	-		-
<b>Maintenance &amp; Repair</b>									
Intravehicular Maintenance & Repair	Rover	L(S)	L(S)	O	O	-	-		-
<b>Habitability Group</b>									
Habitability (Housekeeping, WHC, Food & Trash Management)	Rover	S	S	S	S	S	S		S
<b>Photo/TV</b>									
Photo/TV	Rover	-	-	-	-	-	-		-
<b>Extravehicular Activity (EVA)</b>									
EVA (EVA Operations, EVA Hardware (internal tasks), and EVA Coordination)   micro-G and Surface	Rover	L = EVA	L = EVA	L = EVA	L = EVA	-	-		-
EV Suit Only   micro-G and Surface	Rover	-	-	-	-	S (All surface crew not already EVA leads)	S (All surface crew not already EVA leads)		S (All surface crew not already EVA leads)
<b>Integrated Medical Operations</b>									
Crew Medical Officer   Medical Treatment for Surface EVA Medical Emergencies	Rover	L(S)	L(S)	S	S	S	S		S
Medical Operations   Exercise Countermeasures, Environmental Sampling (e.g., radiation monitoring, acoustic monitoring)	Rover	O	O	O	O	O	O		O
<b>Robotics Operations</b>									
Robotics Operations (Planetary Surface)	Rover	S	S	-	-	-	-		-
Track & Capture	Rover	-	-	-	-	-	-		-
<b>Payloads Group (PLG)   NEW DESIGNATIONS FOR MARS</b>									
Surface Geological Science	Rover	L (Same as EVA lead)	L (Same as EVA lead)	L (Same as EVA lead)	L (Same as EVA lead)	-	-		-

**Table 86. The Generic Mars – Mars Ascent Vehicle (MAV)**

		Mars Ascent Vehicle (MAV) Crew Qualification & Responsibilities							
ROLES (Full Crew)	Vehicle	The first six columns indicate the recommended number of crewmembers and qualifications for each responsibility out of a crew up to six. The last column indicates the number of qualifications for additional crew sizes.							
Mars Commander / Flight Engineer	MAV	CDR	PLT	FE	FE	FE	FE		FE
<b>SYSTEM QUALIFICATION &amp; RESPONSIBILITIES</b>									
<b>Piloting Operations</b>									
Piloting (Ascent/Rndz/Entry)	MAV	PLT	PLT	MS	MS	MS	MS		MS
<b>Complex Operations</b>									
Emergency Operations	MAV	PLT	PLT	MS	MS	MS	MS		MS
Activation/Deactivation	MAV	PLT	PLT	MS	MS	MS	MS		MS
<b>Logistics (Transfer, Inventory &amp; Stowage)</b>									
Logistics (Transfer, Inventory & Stowage)   One Specialist is Loadmaster	MAV	-	-	-	-	-	-		-
<b>Vehicle Core Systems (CDH, C&amp;T, ECLSS, EPS, MCS, Propulsion, ITCS, ETCS)</b>									
Vehicle Core Systems (CDH, C&T, ECLSS, EPS, MCS, TCS)	MAV	PLT	PLT	MS	MS	MS	MS		MS
<b>Structure &amp; Mechanisms, Maintenance &amp; Repair</b>									
Structures & Mechanisms, Intravehicular Maintenance & Repair	MAV	PLT	PLT	MS	MS	MS	MS		MS
<b>Habitability Group</b>									
Habitability (Housekeeping, WHC, Food & Trash Management)	MAV	PLT	PLT	MS	MS	MS	MS		MS
<b>Photo/TV</b>									
Photo/TV	MAV	-	-	-	-	-	-		-
<b>Extravehicular Activity (EVA)</b>									
EVA (EVA Operations, EVA Hardware (internal tasks), and EVA Coordination)   micro-G and Surface	MAV	-	-	-	-	-	-		-
EV Suit Only   micro-G and Surface	MAV	-	-	-	-	-	-		-
<b>Integrated Medical Operations</b>									
Crew Medical Officer   Medical Treatment	MAV	PLT	PLT	MS	MS	MS	MS		MS
Medical Operations   Countermeasures, Environmental Sampling (e.g., radiation monitoring, acoustic monitoring)	MAV	PLT	PLT	MS	MS	MS	MS		MS
<b>Robotics Operations</b>									
Robotics Operations (incl. EVA Robotics (EVR))	MDV	-	-	-	-	-	-		-
Track & Capture	Rover	-	-	-	-	-	-		-
<b>Payloads Group (PLG)</b>									
Payloads Group	MDV	-	-	-	-	-	-		-

**Training Flow Hours**

The Generic Mars CQRM “reflects the qualification levels achieved in training” [ref. 46]. To model a flight-assigned Mars CQRM that balances the training workload across a crew, the assessment team determined training hours for each responsibility and level of qualification in the Generic Mars CQRM using quantitative data from the ISS and SpaceX Dragon training flows, as applicable.

For operator (O) and specialist (S) responsibilities, the assessment team used the training flow hours documented for formal training in the Fox learning management system maintained by FOD. For example, the assessment team use ISS Operator training flow hours for Transit Habitat Operator training flow hours. The assessment team assigned Pilot (PLT) and Mission Specialist (MS) training hours using MPCV training flow hours.

The lead (L) qualifications for vehicle systems are new, Mars-unique qualifications. The assessment team conducted SME interviews to determine equivalent training flows for these qualifications. An ISS SPARTAN flight controller/instructor recommended using MPSR flight controller training flow hours for lead vehicle core systems. The SPARTAN noted that while MPSR training flow content would not be identical to the content in a crew lead training flow for a system or operation (e.g., for core systems the crew would be provided more practical, hands-

on system training and would not be required to complete essay-type knowledge requirements or oral-board evaluations required of MPSR flight controllers) the total Fox training hours would be very similar and “a good ceiling for a crew system lead training flow”<sup>24</sup>. A former ISS Gemini Titan<sup>25</sup> flight controller recommended 3 to 4 months of training per vehicle core system based on her experience learning a new system. This is a different approach to considering crew training hours than considered by the SPARTAN flight controller/instructor, but it aligns with the number of hours from the SPARTAN recommendation of using MPSR hours. Based on these interviews, the assessment team used the MPSR training flow hours documented for formal training in the Fox learning management system maintained by FOD. The assessment team used MPSR training hours rather than the Gemini experience since the MPSR training hours provide more recent and better documented data. System lead qualifications for Mars require significantly more flight-assigned training hours training than training for current ISS qualifications (e.g., 370 hours of training for a Mars Transit Habitat ECLSS lead, compared to 24 hours of training for an ISS ECLSS specialist).

The EVA lead qualification is a new, Mars-unique qualification. As was noted, ISS uses the lead qualification for EV crewmembers, but the Mars EVA lead qualification described here expands the responsibilities to include the EVA coordination responsibilities for crewmembers on missions to Mars currently performed for ISS EVAs by the MCC flight control team. The assessment team conducted a SME interview to determine an equivalent training flow for this qualification. An ISS EVA flight controller/instructor recommended using EVA MPSR flight controller training flow hours for EVA lead training hours. The assessment team used the MPSR training flow hours documented for formal training in the Fox learning management system maintained by FOD. For the EVA lead, the assessment team used the total sum of training hours for two MPSR positions, EVA Task and EVA systems. A flight controller hired into the EVA discipline normally takes ~3 years to certify in their first of two MPSR positions. A new-hire first becomes an instructor for a position and then works towards their MPSR certification. The flight controller in training may take weeks of self-study time to learn lessons for their instructional requirements or to prepare for knowledge requirements, and these hours are not included in the Fox training flow (and are not required for an EVA lead crewmember). For a crewmember to complete the formal training in Fox included in these flows would take months rather than years (on the order of a lead flow for a vehicle core system). The total hours for the EVA lead include the ISS hours for EV qualifications which train the crew for IV tasks (e.g., suit maintenance) and extravehicular operations. EVA lead qualifications for Mars require significantly more flight-assigned training hours than training for current ISS qualifications (e.g., 572 hours of training for a Mars EVA lead, compared to 128 hours of training for ISS EVA operations).

---

<sup>24</sup> Personal communication SPARTAN flight controller/instructor, 2023.

<sup>25</sup> Early in the life of the ISS Program, FOD implemented a concept of Gemini flight controllers, where two flight controllers, Atlas and Titan, replaced the team of core system flight controllers for overnight and weekend shifts. Atlas and Titan flight controllers were certified in one of the three systems assigned to them and received training as a Gemini flight controller for their responsibilities for two additional systems. An Atlas had responsibility for the ECLSS, EPS, and TCS systems, and a Titan had responsibility for the C&T, CDH, and MCS systems. Atlas and Titan had sufficient knowledge of their respective set of systems to be capable of safing vehicle systems in response to off-nominal events.



The assessment team used a SME interview to determine training flow hours for the robotics specialist qualification. An ISS robotics flight controller/instructor recommended doubling the ISS flight-assigned robotics flow to add failure identification and recovery to the crew training flow. The ISS robotics flight controller/instructor noted that this content was trained to early ISS expedition crew; however, over the years of the ISS Program these tasks were transitioned to the ground and removed from crew training. The SME noted that this training would only apply to Transit Habitat robotics and, based on Artemis experience, planetary surface robotics capabilities (e.g., drone, robotic arm, etc.) would likely be provided by a different contractor, so the crew would require a separate training flow for planetary surface robotics. The assessment team used the Transit Habitat hours as estimates for a separate surface robotics training flow.

The full Excel<sup>®</sup> spreadsheet for the Generic Mars CQRM stored on the assessment SharePoint site lists the specific ISS or SpaceX Dragon training flows and hours used to estimate Mars mission training hours for each qualification level for each responsibility, including the hours for the new lead qualifications. The spreadsheet notes any deviations from the descriptions above.

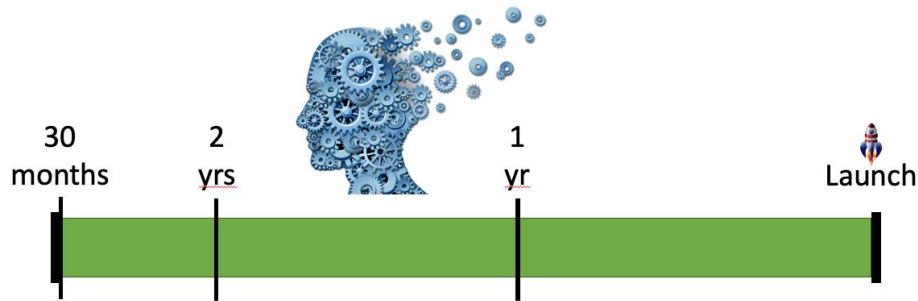
### ***Human Performance Limitations***

The Generic Mars CQRM is built to identify the minimum crew qualifications for each area of responsibility necessary for a Mars mission. However, human limitations on skill acquisition and retention need to be considered in modeling a flight-assigned Mars CQRM. To determine these limits for missions to Mars, the assessment team interviewed FOD SMEs and reviewed FOD literature on training retention issues. The team identified constraints on the overall duration of flight-assigned training (number of years) and constraints on the allocation of lead qualifications (including piloting, EVA, and system leads) to which a crewmember can be trained to retention.

### ***Training Constraints: Duration of Flight-Assigned Training Flow***

When astronaut candidates (ASCANs) are hired into the Agency, they are provided 2 years of ASCAN training, during which they are evaluated on multiple vehicle systems, operations, and payloads. After successfully completing ASCAN training, flight-assigned training begins when a crewmember is assigned to an ISS increment or Artemis mission. In the early years of ISS, flight-assigned training frequently ran longer than 30 months. Although the ISS crew training program produces highly skilled and effective crewmembers, training retention issues seen in the ISS crew were a known concern for FOD [refs. 48, 49]. Over the course of the ISS Program, FOD conducted several dedicated efforts to refine ISS training. In 2016, the Training Reduction Action resulted in a redesign of the ISS pre-mission, flight-assigned flow that reduced the duration of pre-mission training to less than a 24-month flow, in part due to “knowledge retention issues” (Figure 143) [ref. 50]. Additional efforts have reduced the duration of the flow even further, so that flight-assigned crew are now in training between 17 months (for a crewmember travelling to ISS on SpaceX Dragon as mission specialist) to 20.5 months (for a crewmember travelling to ISS as a Soyuz right-seater) [ref. 51]. NASA’s HRP Evidence Report for the Risk of Inadequate Human-System Integration Architecture states that, “there is a possibility of adverse outcomes in the performance of critical mission tasks” if training retention issues are not addressed [ref. 40]. Therefore, it is critical that pre-flight training for Mars remains within limits that can be effectively trained.

# ISS Knowledge Retention Issues



**Figure 143. Knowledge Retention Issues in ISS Crew Pre-mission Training [ref. 50]**

To determine a valid duration for modeling Mars flight-assigned training, the assessment team used the information above and interviewed experienced ISS instructors, flight controllers, and crew. SMEs expressed concerns about extending a Mars pre-mission, flight-assigned flow beyond 24 months, with one SME (a flight controller/instructor) noting that longer flows would require proficiency training for content trained earlier in the flow creating even more of a challenge. Another SME (a crewmember) clearly stated that 2 years is the maximum duration that should be considered for a Mars pre-mission, flight-assigned training flow.

Based on ISS operational training limits and SME inputs, the assessment team set a maximum duration of 2 years in the model for a Mars pre-mission, flight-assigned training flow.

## ***Training Constraints: Allocation of Areas of Expertise***

The second training constraint that the assessment team considered was the constraint on the allocation of lead qualifications (including piloting, EVA, and system leads) to which a crewmember can be trained to retention. Table 87 shows the full listing of piloting, EVA, and system leads across the five vehicles in the Generic Mars CQRM. While a crewmember can be assigned more than one of the responsibilities listed in the table, human limitations on skill acquisition and retention need to be considered in modeling a flight-assigned Mars CQRM.

**Table 87. Piloting, EVA, and System Leads**

Generic Mars Crew Qualification & Responsibilities Matrix (CQRM)			
Piloting, EVA, and Lead Responsibilities			
Piloting and Lead Assignments			
Piloting (Ascent/Rndz/Entry)	Orion	PLT	PLT
Emergency Operations (Emer)	Transit Habitat	L	L
Command & Data Handling (CDH) w/LAN	Transit Habitat	L	L
Communication & Tracking (C&T)	Transit Habitat	L	L
Environmental Control & Life Support System (ECLSS)	Transit Habitat	L	L
Electrical Power System (EPS)	Transit Habitat	L	L
Motion Control System (MCS)	Transit Habitat	L	L
Transit Propulsion System (Prop)	Transit Habitat	L	L
Thermal Control System (TCS)	Transit Habitat	L	L
Structures & Mechanisms (Incl. Docking Systems)	Transit Habitat	L	L
Maintenance & Repair (IVA Tools & Generic Tasks)	Transit Habitat	L	L
EVA (EVA Operations, EVA Hardware (internal tasks), and EVA Coord.)   micro-G and Surface	Transit Habitat & Rover	EVA (multiple crewmembers)	
Piloting (Ascent/Rndz/Entry)	MDV	PLT	PLT
Activation/Deactivation (MDV)	MDV	PLT	PLT
Driving & Navigating	Rover	L	L
Emergency Operations	Rover	L	L
Activation/Deactivation (Rover and External Equipment)	Rover	L	L
Vehicle Core Systems (CDH w/LAN, C&T, EPS, Prop, TCS)	Rover	L	L
Vehicle Core Systems (ECLSS)	Rover	L	L
Structures & Mechanisms (Incl. Docking Systems)	Rover	L	L
Maintenance & Repair (IVA Tools & Generic Tasks)	Rover	L	L
Surface Geological Science	Rover	L	L
Piloting (Ascent/Rndz/Entry)	MAV	PLT	PLT
Activation/Deactivation (MAV)	MAV	PLT	PLT

Developing true expertise requires years of training and practice [ref. 52]. NASA selects experts for some crewmember responsibilities (pilots, medical doctors) and provides spaceflight training that leverages that expertise. For other responsibilities, ISS crewmembers have always been able to rely on the expertise in MCC – in the flight controllers who have spent years in training to be certified on their assigned system, operation, or payloads.<sup>26</sup> For missions to Mars in which crewmembers will be required to perform Earth-independent operations, crewmembers will require some level of expertise to mitigate the risk of unforeseen failures with potential loss of crew/loss of mission consequences and short time-to-effect. The challenge for the spaceflight training instructors is that crewmembers must acquire this expertise in a relatively short period of time (see discussion above on the limits on the duration of training). Furthermore, to mitigate risks across all the vehicles in the architecture, unless the Agency chooses to send dozens of crewmembers on missions that Mars, then crewmembers must be trained to expertise on multiple systems, operations, or payloads. Understanding that there are limitations on skill acquisition and retention, the assessment team conducted interviews and working group meetings

In support of the Personnel, Expertise, and Training model, the SMEs and assessment team provide more than **150 years** of spaceflight training and operational experience.

<sup>26</sup> Training durations for ISS FCR positions vary depending on the discipline and design of the training flow which may include classroom lessons, self-study, training simulations, and evaluations. Additionally, flight controllers are given office duties as they work towards certification. Core system FCR flight controllers are typically certified in 2 to 3 years (which includes a backroom certification). EVA FCR flight controllers can take up to about 8 years to be certified (which includes two backroom certifications).

with FOD and POIC personnel<sup>27</sup> to determine the constraints on the allocation of piloting, EVA, and system lead qualifications to which a single crewmember can be trained for a mission to Mars.

The SMEs included FOD personnel working Artemis, so the SMEs did not simply consider ISS systems but took into account SME knowledge of Artemis vehicles, including Gateway and the lunar rover. The SMEs considered that future Mars vehicles would be smaller and simpler than the ISS, would be more similar to Artemis vehicles than to the ISS, and would have better redundancy management software and automated failure response than seen initially on the ISS based on anticipated Gateway system design.

In interviews with an ISS SPARTAN instructor/flight controller and a former ISS Gemini Titan flight controller, their expert opinion is that future crewmembers could be trained to respond to an unforeseen failure with potential loss of crew/loss of mission consequences and short time-to-effect for a subset of vehicle systems. The Gemini flight controller was confident that a crewmember could be trained to “safe” three vehicle systems (i.e., respond to an unforeseen failure and place a system into a safe configuration). However, the SPARTAN instructor/flight controller noted that their training program includes a case study in which a Gemini flight controller did not maintain expertise across their three systems and did not correctly respond to an ISS system failure – noted to the assessment team as a bounding case for constraints on lead allocations.

The SPARTAN instructor/flight controller noted that some systems are easier to learn and operate (e.g., TCS) while other systems are more challenging to learn and operate (e.g., ECLSS), stating that it is not simply a matter of assigning a number of systems to a crewmember but instead the complexity of each system needs to be considered when grouping systems. Additionally, certain systems combine better than others from a training and operational perspective. For example, EPS and MCS group well because both systems require similar knowledge of the constraints on moving the solar arrays.

Based on interviews and working group meetings with the SMEs, the assessment team set the following as the constraints on the piloting, EVA, and system lead responsibilities to which a single crewmember can be trained:

- MPCV Pilot + EVA
- Transit Habitat Emergency Lead + ECLSS Lead + TCS Lead
- Transit Habitat CDH w/LAN Lead + C&T Lead
- Transit Habitat EPS Lead + MCG Lead + Prop Lead
- Transit Habitat Maintenance and Repair Lead
- MDV/MAV Pilot + Transit Habitat Structures and Mechanisms (Docking) + EVA + Geology

---

<sup>27</sup> The SMEs interviewed for this model included a crewmember, flight director, payload operations director, SPARTAN flight controller, and EVA flight controller. The crewmember is a pilot and brought that expertise to the discussion.

- MDV/MAV Pilot + Transit Habitat Structures and Mechanisms (Docking) + Driving & Navigation
- Rover Emer Lead + ECLSS Lead + (additional CMO training including EVA medical emergency) + EVA + Geology
- Rover Vehicle Core Systems Lead - ECLSS Lead + EVA + Geology
- Rover Structures and Mechanisms Lead + Maintenance and Repair Lead + EVA + Geology

A crewmember assigned to any one of these sets of responsibilities would also be required to be trained live safely onboard each of the vehicles (e.g., trained as operator or specialist on emergency response, habitability, medical operations (e.g., exercise)) and would be assigned additional operator or specialist responsibilities as needed to meet mission objectives. However, these constraints mean that once a crewmember is assigned to one set of piloting, EVA, or system lead responsibilities listed above, he or she would not be assigned additional piloting, EVA, or system lead responsibilities. Therefore, some crew sizes may be too small to have all responsibilities filled at a lead level. As noted, any lead positions that cannot be filled are assigned at the specialist or operator level. (The reader should note that this list of sets of responsibilities was worked iteratively with the development of the models as described below.)

In summary, the assessment team created a Generic Mars CQRM that lists the minimum crew qualifications for each area of responsibility necessary to meet primary mission objectives, to perform time-critical operations, and respond to unforeseen failures across each vehicle. Using quantitative data from NASA's ISS and SpaceX Dragon training flows, the assessment team documented the pre-mission, flight-assigned training hours necessary to achieve a specified qualification for each area of responsibility assigned to the crew. The team conducted SME interviews and reviewed operational data to document constraints on the duration of a Mars flight-assigned training flow. The team conducted SME interviews and working group meetings to document constraints on the piloting, EVA, and system lead responsibilities to which a single crewmember can be trained.

### ***Model Design***

The Personnel, Expertise, and Training model is an optimization model with the objective of balancing the training hours across a crew, given an allocation of lead, piloting, and EVA responsibilities and given a 2-year limitation on flight-assigned training. Specifically, the model allocates qualifications to the crew across the entire CQRM, following rules on assignments including:

- Each crewmember is deterministically assigned a fixed allocation of piloting, EVA, and system lead responsibilities.
- Any lead qualifications in the Generic Mars CQRM not assigned to a crewmember are changed to specialist or operator (e.g., if a second lead is not assigned to the Transit Habitat CDH system that qualification is change to specialist).
- All crewmembers are assigned operator or specialist duties for responsibilities levied on all crew as specified in the Generic Mars CQRM (e.g., all crewmembers are assigned as specialists for logistics and habitability for the Transit Habitat).

- The remaining operator and specialist responsibilities are randomly assigned to optimize the balance of training hours across the crew (e.g., any crewmember could be assigned as the Transit Habitat CDH specialist).
- Additional modeling rules are shown in the model spreadsheet on the NESC SharePoint (e.g., assigning certain crewmembers to remain on-orbit).

These rules were built into an optimization model within the Mars CQRM data sheet that minimizes the difference between the most training hours and the least training hours among all crewmembers. The model outputs a flight-assigned Mars CQRM showing the CDR, operator, specialist, lead, piloting, and EVA responsibilities assigned to each crewmember and calculates the number of training hours for each crewmember.

A MCS scheme was established within the Excel® add-on simulation tool Crystal Ball that takes random samples from all possible permutations and combinations specialist and operator assignments. The MCS runs generate 500,000 specialist and operator assignments, and the flight-assigned Mars CQRM with the least difference among training hours across the crew is taken as the optimized crew assignment. This optimized crew assignment very well approximates the best balance of training hours.

	A	B	C	N	O	P	T	U	V	W	X	Y	Z	AA	AB	AC	AD	AE	AF	AG	AH	AI
2		Generic Mars		MS	L	\$	1	2	3	4	5	6	7	8	9	10	11	12			2.2	
3							Crew Name and Training hrs												Notes or D.	Rules fixed or	RV	Total Comb.
4		ROLES (Full Crew)	Vehicle	Mission Specialist (MS) (equiv. to MS for SpaceX or Orion D.)	Lead (L) (able to take the vehicle or operations outside scope of procedures)	Current Analogs (R) (equiv. to ISS specialist)	A	B	C	D	E	F	G	H	I	J	K	L				1.9E+24
135		Robotics Operations	Rover																			
136		Robotics Operations (Planetary Surface)	Rover			74.00								74					74	Randomly selected S: 2 out of 6 from the crew to surface	Random	15
137		Track & Capture	Rover																			
171						Total Hrs	1684.75	1638.50	1516.20	1378.28	1650.43	1399.41	2198.59	2092.59	2219.98	2281.48	2453.75	2230.33	22744.29			

**Figure 144. Optimization of Assignments**

Figure 144 illustrates the MCS approach for the Personnel, Training, and Expertise model with a total of 12 crew (A to L) and 6 of the 12 (G to L) going to the Mars surface. Column AF of the spreadsheet shows the random assignment rule for assigning two crewmembers as robotics specialists on the surface (Randomly selected S: 2 out of 6 from the crew to surface). Column AH is the uniform random variable generated from the Crystal Ball tool. Column AI has a value 15 indicating there are 15 total permutations of 2 out of 6. Column Z and AE indicates Crew G and Crew L takes the specialist role from this random assignment with 74 training hours for each person. Total pre-mission, flight-assigned training hours for each crew are summarized at the bottom of the spreadsheet as shown on Row 171.

### 7.2.5.3 Assumptions and Model Limitations

The model assumptions and limitations include:

#### Assumptions:

- Assume SAC22 architecture (MPCV, Transit Habitat, MDV, Rover, MAV) with a 30-day short stay on the Martian surface and significant delays in communication.
- Assume deep space network communication infrastructure that provides for continual but communication delay support from MCC (including Earth-based antennas and in-space relay between Earth and Mars).

- Assume communication that provides for continual communication between Mars surface crew and Mars crew in orbit.
- Assume ASCAN training completed prior to Mars flight-assigned training.
- Assume the ISS and SpaceX Dragon programs of training are valid analogs for Mars flight-assigned training.
- Assume vehicles in the Mars architecture have the information infrastructure and decision-support necessary for the crew to respond to unforeseen failures.

*Limitations:*

- There are not objective measures of spaceflight training limitations, either in years of training or in the number or groupings of systems, operations, or payloads to which a crewmember can be trained to retention.
- There may be important differences between the analog vehicles used in this report and the vehicles in the final Mars mission architecture. Differences in vehicles may translate to differences in training hours, in training constraints, and in the expertise necessary to respond to unforeseen failures.
- There may be a need for higher levels of expertise on the planetary surface for long-stay missions, including for additional surface infrastructure.
- The model balances the training load across the crew but does not balance the in-mission workload.

#### **7.2.5.4 Results and Discussion**

The assessment team led working group meetings with SMEs to determine models to build. Based on these meetings, the assessment team built two flight-assigned Mars CQRM models, a flight-assigned Mars CQRM for a four-person crew with two to the surface and a flight-assigned Mars CQRM with a twelve-person crew with six to the surface. The assessment team led the SMEs through evaluations of these flight-assigned Mars CQRM using the trade space framework to guide the evaluation discussion.<sup>28</sup> These two models provide two examples of a systematic, repeatable process that can be used for evaluating as many other crew sizes (number of crew and expertise) as desired, they are not recommendations on crew size. As stated below, in discussing the results of the twelve-person model, the SMEs agreed that they could not go further in their considerations of the need for vehicle system leads (to drive down crew size to build a third model for analysis) without a better understanding of future vehicles.

##### *Analysis 1 - 2021 Reference Missions with Four-Person Crew with Two to Surface*

While any size crew can be modeled using this methodology, the first model the assessment team built for analysis was based on the 2021 Agency guidance of a four-person crew with two crewmembers descending to the surface. To build this model, the assessment team conducted SME working group meetings to determine the piloting, EVA, and lead qualifications to assign to the four crewmembers. NASA assigns two pilots to each ascent/entry vehicle to ensure redundancy in critical piloting operations. The working group determined there were two primary options for assigning ascent/entry vehicle pilots: either two crewmembers would pilot all ascent/entry vehicles or two would pilot the MPCV crew module during operations around Earth

---

<sup>28</sup> The assessment team lead the SMEs through evaluations of the flight-assigned CQRM as decisions were being made as well as after all model results were completed, involving a more iterative process than that used by the robotic arm assisted EVA operator modeling team who conducted a formal evaluation session at the conclusion of their modeling.

or cislunar space and the other two would pilot the MDV and MAV to and from the Martian surface. As an aside, the assessment team included piloting duties for the Transit Habitat within propulsion system responsibilities. Based on the recommendation of the crewmember on the working group (who is also a pilot), the assessment team built the model using the 2 x 2 approach: two crewmembers would pilot the MPCV and the other two would pilot the MDV and MAV. The working group recommended all four crewmembers be EVA qualified to ensure redundancy in pairs of EVA crew for the transit to and from Mars while also ensuring both crewmembers to the surface would be EVA qualified. The working group determined that an MPCV pilot with an EVA lead qualification would be a full allocation of set of responsibilities for a single crewmember.

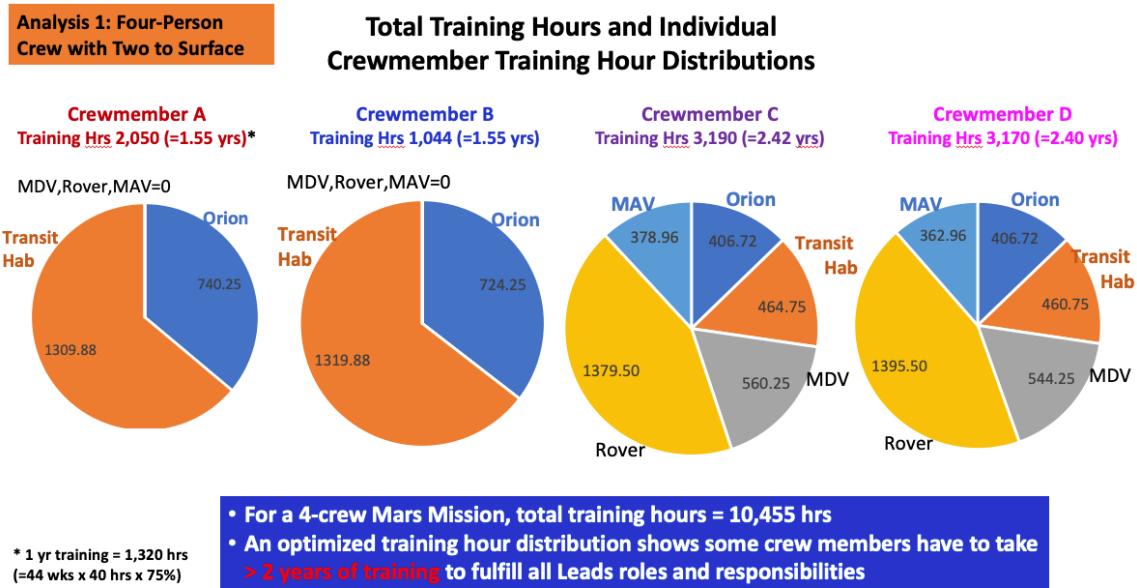


**Table 88. Mars CQRM Overview for Four Crew**

Mars CQRM for Four Crew Piloting, EVA, and Lead Responsibilities in Blue	Vehicle	Crewmember A	Crewmember B	Crewmember C	Crewmember D
		(Orion PLT + EVA Lead)	(Orion PLT + EVA Lead)	(MDV PLT + MAV PLT + Docking Lead + EVA + Geology Lead + Driving & Nav. Lead + Rover Act/Deact. Lead)	(MDV PLT + MAV PLT + Docking Lead + EVA + Geology Lead + Driving & Nav. Lead + Rover Act/Deact. Lead)
CDR	MPCV	CDR	-	-	-
Piloting	MPCV	PLT	PLT	MS	MS
Vehicle Core Systems	MPCV	PLT	PLT	-	-
Emer Response + Habitability + All Other Operations	MPCV	PLT	PLT	MS	MS
CDR	Transit Habitat	-	CDR	-	-
Emer Lead + ECLSS Lead + TCS Lead	Transit Habitat	S	S	O	O
CDH w/LAN Lead + C&T Lead	Transit Habitat	S	S	O	O
EPS Lead + MCG Lead + Prop Lead	Transit Habitat	S	S	O	O
Maintenance & Repair (IVA Tools & Generic Tasks) Lead	Transit Habitat	S	S	O	O
Struc & Mech (Docking) Lead	Transit Habitat	O	O	L	L
Logistics	Transit Habitat	S	S	S	S
Habitability	Transit Habitat	S	S	S	S
Photo/TV	Transit Habitat	S	S	S	S
CMO	Transit Habitat	S	S	O	O
Robotics Ops	Transit Habitat	S	S	-	-
Med. Ops (incl. Exercise Countermeasures)	Transit Habitat	O	O	O	O
EVA Lead   micro-g and Surface	Transit Habitat	EVA	EVA	(See Rover EVA Leads)	(See Rover EVA Leads)
Payloads	Transit Habitat	S	S	-	-
CDR	MDV			CDR	-
Piloting	MDV			PLT	PLT
Vehicle Core Systems	MDV			PLT	PLT
Emer Response + Habitability + All Other Operations	MDV			PLT	PLT
CDR	Rover			-	CDR
Driving & Navigation Lead + Rover Act./Deact. Lead	Rover			L	L
Emer Lead + ECLSS Lead + (additional CMO training incl. EVA medical emergency)	Rover			O + S + L (CMO)	O + S + L (CMO)
Vehicle Core Systems Lead - ECLSS Lead	Rover			S	S
Struc & Mech Lead + Maint. & Repair Lead	Rover			S	S
Logistics	Rover			S	S
Habitability	Rover			S	S
CMO	Rover			(see above)	(see above)
Med. Ops (incl. Exercise Countermeasures)	Rover			O	O
Robotics Ops	Rover			S	S
EVA Lead   micro-g and Surface	Rover			EVA	EVA
Geology Lead (adds to all surface EVA leads)	Rover			L	L
CDR	MAV			CDR	-
Piloting	MAV			PLT	PLT
Vehicle Core Systems	MAV			PLT	PLT
Emer Response + Habitability + All Other Operations	MAV			PLT	PLT

The working group then discussed the additional responsibilities necessary to assign to the MDV/MAV pilots to meet primary mission objectives. In addition to piloting and EVA responsibilities, these two crewmembers would also need to be assigned as leads for the Transit Habitat docking systems (for docking and undocking the MDV and MAV from the Transit

Habitat), as leads for Rover navigation and activation/deactivation, as leads for additional crew medical officer (CMO) training including EVA medical emergency response, and as leads for geology. After creating this list, the working group determined that this would be too many piloting, EVA, and lead qualifications for one crewmember to be assigned. Nonetheless, the assessment team built a model for this crew. Figure 145 shows an overview of the flight-assigned Mars CQRM modeled for a crew of four based on the working group discussions.



**Figure 145. Training Hours for a Four-Person Crew**

The model output shows that the two MPCV pilots could be trained within the 2-year limitation on pre-mission, flight-assigned training (Figure 145), and the SMEs determined that the allocation of piloting and lead for the MPCV pilots was reasonable. However, the two MDV/MAV pilots would require more than 2 years of pre-mission, flight assigned training.

In evaluating this flight-assigned Mars CQRM using guidance from the evaluation framework, the SMEs identified the following risks:

- For this modeled four-person crew Mars CQRM, the MDV/MAV pilots exceed the allocation of piloting, lead, EVA assignments for one crewmember, per SME evaluation, and will not likely be able to perform all responsibilities to the level necessary to meet primary mission objectives nor be likely to successfully respond to unforeseen failures with potential loss of crew/loss of mission consequences and short time-to-effect for all assigned responsibilities.
- For this modeled four-person crew Mars CQRM, there are no leads assigned to Transit Habitat systems, meaning the crew will likely not have the capability to respond successfully to unforeseen failures with potential loss of crew/loss of mission consequences and short time-to-effect for Transit Habitat systems.
- For this modeled four-person crew Mars CQRM, there are no leads assigned to the Rover systems, meaning the crew will likely not have the capability to respond successfully to unforeseen failures with potential loss of crew/loss of mission consequences and short time-to-effect for Rover systems.

- Additionally, for this modeled four-person crew Mars CQRM, there are only two IV crewmembers to support EVA operations. Per the findings of the IV Operations for Planetary Surface EVA model, two crewmembers would not be able to adequately manage the workload necessary to provide real-time support to crewmembers performing an EVA on the surface of Mars for technical EVAs operated at the pace of an ISS EVA.

**F-19.** A Mars CQRM indicates that a split crew of four (with two to the surface) would not have the necessary expertise to meet primary mission objectives or respond successfully to unforeseen/short time-to-effect failures in the Transit Habitat with potential loss of crew/loss of mission consequences.

**F-20.** A Mars CQRM indicates that a crew of two to the surface would not have the necessary expertise to meet primary mission objectives or respond successfully to unforeseen/short time-to-effect failures in the Rover with potential loss of crew/loss of mission consequences.

### *Analysis 2 – Mission with Twelve-Person Crew with Six to Surface*

The second model the assessment team built for analysis came about as a result of the discussions in evaluating the first model. In addition to the concerns expressed by SMEs about the training load on the two crew to the surface in the four-person crew model, they also expressed concerns about capability within the four-person crew to respond successfully to unforeseen failures with loss of crew/loss of mission consequences in transit and on the Martian surface. The SMEs did not suggest a specific crew size to model but instead chose to exercise this methodology to address risk mitigation.

With this in mind, the SMEs began discussions on a second model by considering a crew size that allowed for more than two crewmembers to the surface. This model was also built using the 2 x 2 approach for assigning ascent/entry vehicle pilots: two crewmembers would pilot the MPCV (during operations around Earth or cislunar space) and the other two would pilot the MDV and MAV (to and from the Martian surface). The SMEs initially discussed assigning all crewmembers to the surface as EVA leads, although they decided that the MDV/MAV pilots would not need to be geology leads.

In considering the risks to the mission, the SMEs decided on assigning two crewmembers as leads for Rover emergency response (Emer), ECLSS, and for additional CMO training including EVA medical emergency response. Assigning at least four crew to EVA on the surface ensures pairs of EVA crew, and assigning two of these crewmembers as Emer Lead + ECLSS Lead + additional CMO training ensures that one of these crewmembers could always remain inside the vehicle in the event of an emergency on the Rover or a medical emergency during an EVA. The group decided on one lead each for the two additional Rover lead allocations to provide the crew with the capability to respond to unforeseen failures in Rover systems. The assessment team placed these decisions into the CQRM and found this drove the surface crew size to seven.

In an effort to reduce this number, the SMEs decided to remove the EVA lead assignment from the MDV/MAV pilots and reassign them to Rover Driving and Navigation Lead + Rover Act./Deact. Lead. The SMEs suggested that a new surface responsibility of EVA specialist be created for suit walk-back on the surface in the event of an off-nominal condition, and the MDV/MAV pilots were assigned to this responsibility. This decision reduced the surface crew to six.

The SMEs then discussed the Transit Habitat assignments. Recognizing that lead assignments provide capability in the crew to respond to unforeseen failures, the SMEs spent time discussing whether all Transit Habitat vehicle systems would require leads. Points in their discussion included:

- Whether the crew may be able to rely on redundancy in future vehicles to safe vehicle systems rather than needing leads for all systems.
- Whether systems on future vehicles would need to be managed in the way ISS systems need to be managed – driving the need for leads to respond to unforeseen failures for those systems (e.g., EPS) that do need to be managed.
- Whether different combinations of lead allocations might drive the need for fewer leads.
- How much control the crew will have over future communication networks, or whether the ground would be responsible for these networks.

While the SMEs have knowledge of new Artemis systems under design, there remains significant uncertainty about future systems. Therefore, the SMEs decided on assigning one lead for each of the four sets of allocations for the Transit Habitat core vehicle systems to ensure the capability within the crew to respond to unforeseen failures with potential loss of crew/loss of mission consequences and short time-to-effect.

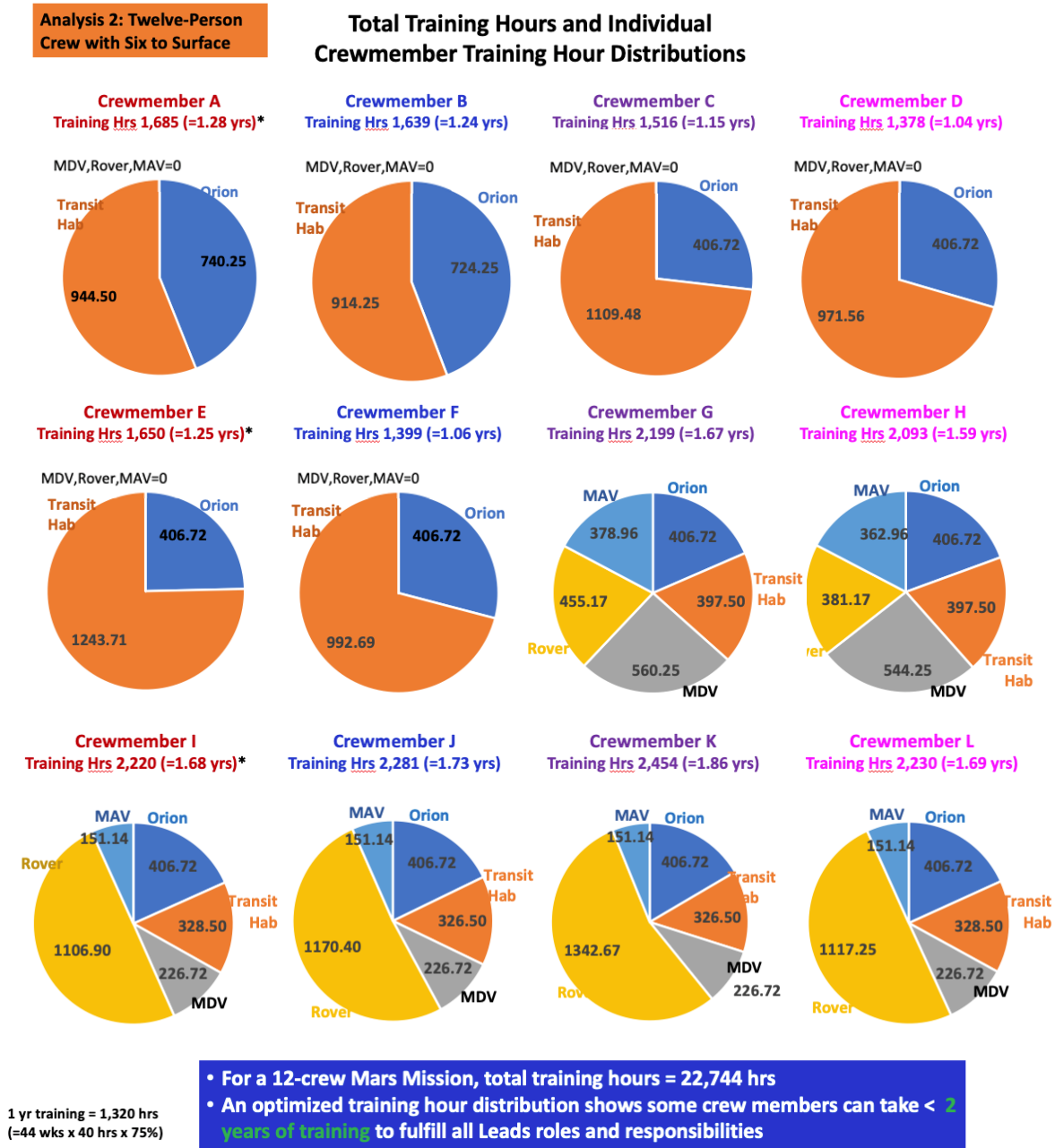
Table 89 shows an overview of the flight-assigned Mars CQRM modeled for a crew of 12 based on the working group discussions.

**Table 89. CQRM Overview for Twelve Crew**

Mars CQRM for Twelve Crew Piloting, EVA, and Lead Responsibilities in Blue	Vehicle	Crewmember A	Crewmember B	Crewmember C	Crewmember D	Crewmember E	Crewmember F	Crewmember G	Crewmember H	Crewmember I	Crewmember J	Crewmember K	Crewmember L
		(Orion PLT + EVA Lead)	(Orion PLT + EVA Lead)	(Emer Lead + ECLSS Lead + TCS Lead)	(CDH w/LAN Lead + C&T Lead)	(EPS Lead + MCG Lead + Prop Lead)	(Maint. & Repair Lead)	(MDV PLT + MAV PLT + Docking Lead + Driving & Nav. Lead + Rover Act/Deact. Lead)	(MDV PLT + MAV PLT + Docking Lead + Driving & Nav. Lead + Rover Act/Deact. Lead)	(Emer Lead + ECLSS Lead + CMO Lead + EVA Lead + Geology Lead)	(Emer Lead + ECLSS Lead + CMO Lead + EVA Lead + Geology Lead)	(Vehicle Core Systems Lead - ECLSS Lead + EVA Lead + Geology Lead)	(Struc & Mech Lead + Maint. & Repair Lead + EVA Lead + Geology Lead)
CDR	MPCV	CDR	-	-	-	-	-	-	-	-	-	-	-
Piloting	MPCV	PLT	PLT	MS	MS	MS	MS	MS	MS	MS	MS	MS	MS
Vehicle Core Systems	MPCV	PLT	PLT	-	-	-	-	-	-	-	-	-	-
Emer Response + Habitability + All Other Operations	MPCV	PLT	PLT	MS	MS	MS	MS	MS	MS	MS	MS	MS	MS
CDR	Transit Habitat	-	-	CDR	-	-	-	-	-	-	-	-	-
Emergency Operations (Emergency Response)	Transit Habitat	O	O	(See Lead)	O	O	O	O	O	O	O	O	O
Emer Lead + ECLSS Lead + TCS Lead	Transit Habitat			L									
CDH w/LAN Lead + C&T Lead	Transit Habitat				L								
EPS Lead + MCG Lead + Prop Lead	Transit Habitat					L							
Maintenance & Repair (IVA Tools & Generic Tasks) Lead	Transit Habitat						L						
Struc & Mech (Docking) Lead	Transit Habitat	-	-	-	-	-	-	L	L	-	-	-	-
Logistics	Transit Habitat	S	S	S	S	S	S	S	S	S	S	S	S
Habitability	Transit Habitat	S	S	S	S	S	S	S	S	S	S	S	S
Photo/TV	Transit Habitat	S	S	S	S	S	S	S	S	S	S	S	S
CMO	Transit Habitat	Two specialists from among the six remaining on orbit, all others are operators (see also Rover additional CMO training for EVA medical emergencies)											
Med. Ops (incl. Exercise Countermeasures)	Transit Habitat	O	O	O	O	O	O	O	O	O	O	O	O
Robotics Ops	Transit Habitat	Two robotics specialist from among the six remaining on orbit.											
EVA Lead   micro-g and Surface	Transit Habitat	EVA	EVA	-	-	-	-	-	-	(See Rover EVA Leads)	(See Rover EVA Leads)	(See Rover EVA Leads)	(See Rover EVA Leads)
Payloads	Transit Habitat	One payload specialist is assigned for each discipline from among the crew.											
CDR	MDV							CDR	-	-	-	-	-
Piloting	MDV							PLT	PLT	MS	MS	MS	MS
Vehicle Core Systems	MDV							PLT	PLT	MS	MS	MS	MS
Emer Response + Habitability + All Other Operations	MDV							PLT	PLT	MS	MS	MS	MS
CDR	Rover							FE	FE	CDR	FE	FE	FE
Driving & Navigation Lead + Rover Act./Deact. Lead	Rover							L	L	-	-	-	-
Emergency Operations (Emergency Response)	Rover							O	O	(See Emer Lead)	(See Emer Lead)	O	O
Emer Lead + ECLSS Lead + (additional CMO training incl. EVA medical emergency)	Rover							-	-	L	L	-	-
Vehicle Core Systems Lead - ECLSS Lead	Rover											L	
Struc & Mech Lead + Maint. & Repair Lead	Rover												L
Logistics	Rover							S	S	S	S	S	S
Habitability	Rover							S	S	S	S	S	S
CMO	Rover							S	S	S	S	S	S
Med. Ops (incl. Exercise Countermeasures)	Rover							S	S	(See Emer Lead)	(See Emer Lead)	S	S
Robotics Ops	Rover							Two robotics specialist from among the six on the surface.					
EVA Lead or EVA Suit Only   micro-g and Surface	Rover							S	S	EVA	EVA	EVA	EVA
Geology Lead (adds to all surface EVA leads)	Rover							-	-	L	L	L	L
CDR	MAV							CDR	-	-	-	-	-
Piloting	MAV							PLT	PLT	MS	MS	MS	MS
Vehicle Core Systems	MAV							PLT	PLT	-	-	-	-
Emer Response + Habitability + All Other Operations	MAV							PLT	PLT	MS	MS	MS	MS



The assessment team built the model for twelve crew adding the SME-discussed assumptions that the MPCV pilots and Transit Habitat system leads remained on-orbit. The model output shows that these twelve crewmembers could be trained within the 2-year limitation on pre-mission, flight-assigned training (Figure 146), and the SMEs determined that the allocation of piloting, EVA, and lead allocations for all twelve crewmembers was reasonable.



**Figure 146. Training Hours for a Twelve-Person Crew**

In evaluating the flight-assigned Mars CQRM for twelve crew using guidance from the evaluation framework, the SMEs identified the following:

- The crew size is significantly larger than the current Agency guidance.

- **This is not a recommended crew size and is not a minimum crew size.**
- With leads assigned to Transit Habitat systems, the crew will likely have the capability to respond successfully to unforeseen failures with potential loss of crew/loss of mission consequences and short time-to-effect for these systems.
- With leads assigned to the Rover systems, the crew will likely have the capability to respond successfully to unforeseen failures with potential loss of crew/loss of mission consequences and short time-to-effect for these systems.
- There is only one lead for most Transit Habitat and Rover vehicle systems, so there is not redundancy in these responsibilities.
- Most importantly, the SMEs stated that this was a valid and necessary process for determining the capabilities that can be built into a crew of a given size – the capabilities to meet primary mission objectives and to respond to unforeseen failures with potential loss of crew/loss of mission consequences and short time-to-effect.
  - *“The logic is good.”*
  - *The Agency will likely “balk at 12. But to mitigate the risk, this is a good way of thinking through it.”*
  - *The temptation will be to “rely on the [vehicle] design [for risk mitigation], but the design will not give them what they want.”*

**F-21.** A Mars CQRM indicates a split crew of twelve (with six to the surface) could successfully meet mission objectives and respond to unforeseen/short time-to-effect failures with loss of crew/loss of mission consequences in the Transit Habitat and Rover.

### 7.2.5.5 Conclusions

The Personnel, Expertise, and Training model is designed to quantify to some measure the trade space between the number of crew and the capability within the crew across systems, operations, and payloads in the real-time environment necessary to successfully meet primary mission objectives and to respond to unforeseen failures with loss of crew/loss of mission consequences and short time-to-effect. A flight-assigned Mars CQRM provides a simple layout that shows the capabilities within a given crew that can be used to evaluate the important considerations in the trade space (e.g., operational impact, training workload, and crew resiliency).

#### *Future Models: Trades in Mission Design Parameters*

The two models built by the assessment team demonstrate a methodology for a systematic, repeatable process for evaluating crew size. In discussing the results of the twelve-person model, the SMEs agreed that they could not go further in their considerations of the need for vehicle system leads (to drive down crew size to build a third model for analysis) without a better understanding of future vehicles and future programs of training. The initial crews to Mars may be deeply involved with the design and development of the vehicles and software they will use on the mission, learning the systems as they are built rather than learning in traditional training flows, giving them a greater understanding of the vehicle, systems, and software to the lead level. Learning the systems as they are built would give them a better understanding of integrated

vehicle systems versus a specialized system or subsystem training flow, which will lead to a better understanding of the impacts and consequences of decisions made outside of the known operations and procedures.<sup>29</sup> The need for leads may also be driven by operational considerations including whether the capability of the MAV to provide an escape-to-orbit in the event of an unforeseen failure on the Rover is provided on a mission to Mars.

As the Agency makes decisions on mission design parameters including vehicle design, training design, and operational concepts, additional models can be built to support trades in those decisions.

### **7.3 Team and Behavioral Health Considerations**

While human performance modeling provides quantitative data on workload and expertise when evaluating trades against dimensions of the trade space, performance impacts at the team and individual level stemming from team and individual behavioral health considerations should also be evaluated. The assessment team provides guidance in this report concerning these considerations.

When considering the number of crewmembers for future Mars missions, there is no “right” number. The discussion presented in this subsection is limited to small teams, that is, three to eight members, given likely engineering, consumables, and cost constraints of sending humans to Mars. Larger teams (six to eight members) seem to offer more benefits to a Mars mission than smaller teams (three to five members), but there are risk tradeoffs that have not been fully quantified in the evidence base. Behavioral health and human factors experts can address potential risks that may stem from different crew sizes.

The Team Risk and related Behavioral Medicine (BMed) Risk areas are focused on understanding the behavioral health and performance impacts at a team and individual level. Areas of concern for the Team Risk include poor cooperation, coordination, communication, and psychosocial adaptation; in other words, how well a team works together and interacts interpersonally [ref. 53]. Areas of concern for the BMed Risk include a decline in psychological well-being, cognitive functioning, or adverse psychological conditions and psychiatric disorders [ref. 54]. Teams and individuals are vulnerable to longer durations, high workloads, fatigue, medical conditions affecting the brain and body, poor training (for technical and soft skills), interpersonal tensions and conflict, and communication delay/blackout. This last factor interferes with space-to-ground operations and create a disconnect from family and friends. Selecting psychological resilient individuals who are also team-oriented and skilled at living together in confined environments is key [ref. 55]. Composing a cohesive crew with a good mix of personalities and the appropriate technical skills is also important. It is critical that exploration crews do not form dysfunctional subgroups or isolate one individual as this causes distress, reduces cohesion, and reduces performance [refs. 54, 56, 57]. Data-driven team composition to find the necessary mix of personalities and avoiding less functional team structures can work as a countermeasure. For example, it is likely advantageous to have an even number of crewmembers, that is, 4 or 6 crewmembers. Even numbers avoid a structural “odd person out” scenario or natural isolation with respect to social and task demands. Even numbers are also able to utilize a “buddy system” for safety and create natural redundancy to leverage for backup. Team process and structure is important for cohesion and performance, with Apollo astronauts

---

<sup>29</sup> M. Sonoda. NASA Flight Operations Directorate, Houston, TX. Personal communication (2023).



identifying these factors as more important than any particular size [refs. 58, 59]. Team coordination, communication, and cooperation processes can be improved through training [ref. 59].

The HSIA Risk area is focused on poor performance and other health outcomes related to poor human factors design and HSI. HSIA is concerned with the technical skills and knowledge needed to complete mission objectives and creating a habitat, equipment, and systems that enable the applicable of those skills and knowledge. Researchers have identified likely tasks, skills, and roles needed for future Mars missions. In one analysis, Stuster and colleagues (2018) created a list of 1125 tasks, with corresponding expertise needs and role distributions for different crew sizes (this assessment expands the work of Stuster and his team) [ref.61]. Burke and colleagues (2020) identified task roles (e.g., leader, coordinator) and social roles (e.g., team builder, entertainer) that should be considered for long-duration missions [ref. 62]. These works, and other past efforts such as the Design Reference Mission plans, are good starting points for determining mission tasks and related skills and knowledge needed on a crew [refs. 63, 64, 65].

The communication delay/blackout from Earth to Mars will force more capabilities (both human and systems) to be flown to Mars. MCC currently flies the vehicles, performs real-time problem identification and troubleshooting, and provides direct support of the crew in space during work and other living tasks [refs. 66, 67]. The real-time multi-team system of current operations will need to shift in the next era of exploration. The previously mentioned Stuster and Burke efforts examining crew roles accounts for this change to flying more capabilities. Each report mapped various roles that are likely candidates for doubling up on one crewmember's responsibilities (e.g., pilot may take on responsibilities for maneuvering rovers, robotics, drones and act as a geologist; social roles may be distributed informally and agnostic of technical roles). Smaller teams would require each crewmember to have even more skills and roles than larger teams in which the skills and roles could be distributed across more crewmembers. The mission commander was identified to also hold multiple responsibilities, one of which was acting as commander and the other would be another technical specialty such as engineer or mechanic. While a shared leadership approach is recommended such that each technical specialist leads tasks in which they are most trained and skilled (e.g., physician leads medical tasks), command of an autonomous mission will necessitate leadership behaviors distinct from task management. In other words, commanding a mission requires specialized knowledge, skills, and abilities [ref. 68]. In larger teams, a commander might be afforded more time to command and lead and reduce other duties to less critical or time burdensome roles. In smaller teams, the commander would need to contribute more to other duties, reducing the available time for commanding. It may be even more important in the latter case to protect time on the commander's timeline for leadership duties, which may not be easy during a high tempo, high workload Mars mission.

When considering behavioral health demands and task demands of a particular mission, mission tasks and objectives should drive the crew size. Once the knowledge, skills, and roles have been mapped to a particular mission's objectives, and a crew size determined, psychological resilience and team composition concerns become the secondary consideration when assigning individuals to that crew. Research can inform the pros and cons of different crew sizes when considering behavioral and task demands and implementing monitoring and countermeasures. Larger teams are generally more flexible and resilient because they have more individuals with a greater diversity of knowledge, skills, and abilities; more individuals available for backup and cross-training of skill redundancies; and more CM-h to get tasks done. Increased CM-h may allow for

more tasks, or for more rest and recovery time. The loss of a crewmember is less devastating to task demands with more individuals. Larger teams have a greater efficacy or belief that they are able to successfully problem-solve and make decisions, which is psychologically supportive [ref. 56]. More individuals translate to more people with which to form social bonds, reducing the risk of isolates and reducing social monotony. This may also help to reduce conflict and lends itself to a less disorganized team structure as people are able to focus on fewer roles and duties [ref. 69]. Conversely, smaller teams (3 to 5) have benefits over larger teams. Smaller crews would have a decreased social density and afford more privacy, which supports psychological well-being [ref. 54]. Designers might reduce the vehicle size and mass for consumables and equipment, reducing costs. In the case of shared equipment, such as hygiene and exercise equipment, fewer crewmembers result in less wear and less maintenance. Reduced resource competition may result in reduced conflict. Smaller teams also have fewer members to communicate across and maintain a shared mental model, enabling coordination. Recent research of teams in Antarctic found that members of smaller teams had less social loafing, and each member contributed more to team performance [ref. 69]. They had high team viability scores, meaning that the teams indicated they would like to stay together over time.

Finally, good HSIA may enable fewer crewmembers. A well-designed environment may reduce the needed skills, training hours, and workload and equipment needed for maintenance. Conversely, inadequate HSIA may necessitate more crewmembers, more highly skilled crewmembers, and more tools, training, and support to accomplish mission tasks and objectives or manage workloads. Behavioral and team demands should be considered in conjunction with tasks demands throughout mission planning.

## **7.4 Summary of Trade Space Analysis and Methodology**

The NESC has developed a systematic and quantitative methodology to aid determination of crew sizes for human Mars missions. This capability was developed out of a recognition that a Mars crew will be denied real-time MCC support, owing to the distance-induced communication delay/blackout with Earth. This fundamental constraint, which is unprecedented in the history of human spaceflight, brings a new appreciation for what the term “crew” encompasses: In every previous program, the flight crew has relied on the combined intellects and energies of experts in the MCC FCR and its back rooms comprising, in essence, additional crewmembers to help them meet primary mission objectives and respond to unforeseen anomalies. On a Mars mission, astronauts making real-time decisions about how to accomplish objectives (i.e., during EVAs) or respond to unforeseen, time-critical failures will have to rely on their collective knowledge when using decision-support systems, whose information would be limited to scenarios that were anticipated before the mission or updated during the mission. The NESC methodology provides a repeatable, systematic, and data-driven means of assessing, based on limited understanding of Mars vehicle systems, whether the capabilities that would exist within a given crew size would be adequate to accomplish primary mission objectives and successfully respond to unforeseen failures with potential loss of crew/loss of mission consequences and short time-to-effect.

The NESC’s quantitative methodology fills a longstanding gap in the tools for designing Mars missions. In the past, crew size determinations have been based on a limited, mostly non-quantitative understanding of the impact of crew workload on mission success and crew survival. Now, in weighing the question of whether a given crew size is adequate to ensure crew survival and mission success, decision-makers can be guided by a systematic, quantitative analysis.

The steps in the methodology are:

- Gather Mars Mission Information
- Determine Use Cases to Model
- Create a Trade Space Evaluation Framework
- Conduct Human Performance Modeling
- Perform Trade Space Analyses

Section 6 of this report provides details on each step of the methodology. Section 7 of this report provides details and results of human performance modeling.

The three IMPRINT models were built based on Mars mission use cases:

- **IV Operations for Planetary Surface EVA Model:** Modeling the mental workload of the IV Mars crewmembers supporting a planetary surface technical EVA.
- **Robotic Arm Assisted EVA Operator Model:** Modeling the mental workload of a Mars crewmember controlling a robotic arm manually or in an automated control mode.
- **Mars Transit Crew Model:** Modeling the level of engagement (i.e., daily workload) of the Mars crew on the transit to Mars.

The fourth custom-built model was based on a Mars mission use case:

- **Personnel, Expertise, and Training Model:** Modeling crew expertise necessary to meet primary mission objectives and respond to unforeseen failures.

Section 7 describes using modeling results to conduct evaluations of crew size against dimensions of the trade space, including: Operational Impact, System Resilience, Human Performance, Team Coordination, Cognitive Support, Organizational Constraints, Costs, Technology Capabilities, and Human Health and Performance.

Future modelers should consider nominal operations and “corner cases”, looking for those challenging scenarios that a crew would need to be able to respond to successfully complete their mission. Modelers should include use cases that require high manpower, high mental workload, or high expertise.

Future modelers should consider build models with different assumptions on mission design parameters including advanced critical technologies, mission objectives and goals, the communication infrastructure, or organizational constraints. Specifically:

*Considerations for Models Built in this Assessment by a future modeling group:*

- Determine the number of crew necessary for supporting an EVA by examining the tasks and workload of all ground personnel who have a real-time involvement in supporting EVAs, requesting combined voice recordings containing all voice inputs and outputs for each MCC controller position and crewmember for modeling future EVAs.
- Assess the effects of task demands, workload management strategies, human/automation roles, personnel fatigue, and automated technology design features and trustworthiness on crewmembers’ workload experiences to inform determination of appropriate crew size.

- Determine the impact on transit crew size from shifting MCC tasks to the crew due to planned windows of communication rather than continual time-delayed communication and due to a communication blackout.
- Ensure the in-mission workload is distributed across the crew as evenly as practical.

*Considerations for Additional Models to Build by a future modeling group:*

- Model additional Mars mission use cases, in support of crew size trade space analysis, that require high manpower, high mental workload, or a high level of expertise.
- Evaluate different crew sizes against mission design parameters including communication infrastructure, technology capabilities (e.g., new technologies and levels of automation), crew resilience, and organizational constraints.
- Incorporate assessment team lessons learned in human performance modeling.
- Initiate data collection to improve modeling efforts.

The analysis results can be used to make recommendations to decision-makers as they consider the potentially competing factors in deciding on Mars mission crew size.

Once a final decision on crew size is made, mission architects should continue to use human performance modeling to prioritize research and engineering projects that will ensure acceptable workload and the necessary expertise in the crew needed to successfully complete the mission. The final step in determining crew size for a mission to Mars is validation that this crew can successfully complete the mission.

## **8.0 Findings and NESC Recommendations**

### **8.1 Findings**

The following findings were identified during this assessment:

- F-1.** Deterministically mandating a Mars mission crew size without consideration of crew workload and expertise increases risk to loss of crew/loss of mission and mission success.
- F-2.** While DoD and NASA have established qualitative and validated workload and human performance models, neither organization has utilized their models in trade space decision-making for determining crew sizes for mission operations.
- F-3.** The DoD IMPRINT tool augmented with the NASA tailored S-PRINT plug-in provides NASA with quantitative analysis capability for crew size decision-making using human performance modeling.
- F-4.** Research literature and prior mental workload studies performed with human performance modeling tools (e.g., IMPRINT/S-PRINT) and utilizing MRT indicate that there are consequences of high or unacceptably high mental workload, including:
  1. Task performance errors.
  2. Increased likelihood of task shedding.
  3. Degraded detection of and response to off-nominal events.
  4. Failure to detect and manage unexpected extra tasks.

#### ***IV Operations for Planetary Surface EVA Model operated at the Pace of an ISS EVA***

- F-5.** IMPRINT modeling results predict that workload for a crewmember performing a combined set of flight director/IV duties will be acceptable in the absence of complex-off-nominal events but will be high during complex off-nominal events.
- F-6.** IMPRINT modeling results predict that workload for a crewmember performing a combined set of EVA, EVA Task, and EMU flight controller duties will be unacceptably high level.
- F-7.** Based on analysis of IMPRINT modeling results and MCC EVA flight controllers SME evaluations, two astronauts orbiting Mars would not be able to adequately manage the workload necessary to provide real-time support to astronauts performing a technical EVA on the surface of Mars.

#### ***Robotic Arm Assisted EVA Operator Model using an ISS Operational Environment***

- F-8.** IMPRINT/S-PRINT modeling results predict that two crew (i.e., an M1 and an M2) will be necessary to mitigate unacceptably high workload of an M1 operating the robotic arm manually (GCA).
- F-9.** IMPRINT/S-PRINT modeling results predict that an M1 using automated (JOCAS) operations without M2 assistance to control the arm will experience high workload given the task complexity and technology characteristics.
- F-10.** IMPRINT/S-PRINT modeling results predict that increasing the salience of failure alerts and ensuring operators have appropriately calibrated trust in automation reduces workload when automated robotic arm control automation fails.
- F-11.** IMPRINT/S-PRINT modeling results predict that sleep debt increases the M1's workload measures and lengthens performance times.

#### ***Mars Transit Crew Model using ISS-equivalent Task Assumptions and assuming Continual Time-delayed Communication Throughout the Mission***

- F-12.** IMPRINT modeling predicts that average rates for unplanned events will reduce the available time for a four-person Mars crew to perform work by 41% compared with a four-person ISS crew.
- F-13.** IMPRINT modeling predicts that 75% confidence level rates for all unplanned events will reduce the available time for a four-person Mars crew to perform work by 50% compared with a four-person ISS crew.
- F-14.** IMPRINT modeling predicts that more than six crewmembers will be needed to achieve the same number of work hours on a Mars transit as on a four-person ISS mission given average rates for all unplanned events.
- F-15.** IMPRINT modeling predicts that more than seven crewmembers will be needed to achieve the same number of work hours on a Mars transit as on a four-person ISS mission given 75% confidence level rates for all unplanned events.

***Personnel, Expertise, and Training Model based on Modeled Crew Training Limits and ISS-equivalent Vehicle System Assumptions and assuming Continual Time-delayed Communication Throughout the Mission***

- F-16.** There is a very high likelihood of unforeseen failures with potential loss of crew/loss of mission consequences and short time-to-effect on crewed Mars missions based on historical trends.
- F-17.** A Mars CQRM can be used to identify the minimum crew qualifications for each area of responsibility necessary for a Mars mission.
- F-18.** To mitigate the risk of unforeseen failures, Mars crew will need to be capable of working outside the scope of procedures, interacting with onboard information and intelligent decision-support systems, and trained to a higher autonomy level than for LEO and lunar missions.
- F-19.** A Mars CQRM indicates that a split crew of four (with two to the surface) would not have the necessary expertise to meet primary mission objectives or respond successfully to unforeseen/short time-to-effect failures in the Transit Habitat with potential loss of crew/loss of mission consequences.
- F-20.** A Mars CQRM indicates that a crew of two to the surface would not have the necessary expertise to meet primary mission objectives or respond successfully to unforeseen/short time-to-effect failures in the Rover with potential loss of crew/loss of mission consequences.
- F-21.** A Mars CQRM indicates a split crew of twelve (with six to the surface) could successfully meet mission objectives and respond to unforeseen/short time-to-effect failures in the Transit Habitat and Rover with loss of crew/loss of mission consequences.

## **8.2 NESC Recommendations**

The following NESC recommendations are directed to ESDMD, SOMD, STMD, and FOD.

- R-1.** Agency decision-makers should consider the crew workload and expertise within the crew necessary to accomplish primary mission objectives and respond to unforeseen failures when considering trades for crew size for Mars missions. *(F-1, F-2, F-3, F-4)*
- R-2.** ESDMD, SOMD, and STMD should coordinate to resource a group to conduct human performance modeling of crew workload and expertise in support of trade space analysis for decision-making on crew size for Mars missions. *(F-1, F-2, F-3, F-4)*
- R-3.** The future modeling group should model and evaluate critical technologies, training capabilities, and operational considerations for Mars missions to inform updates to IMPRINT, S-PRINT, and CQRM models and re-run the analyses. *(F-5, F-6, F-7, F-8, F-9, F-10, F-11, F-12, F-13, F-14, F-15, F-16, F-17, F-18, F-19)*
- R-4.** ESDMD, SOMD, and STMD should prioritize research and engineering projects that will ensure acceptable crew workload and expertise within the crew necessary successfully accomplish the mission. *(F-5, F-6, F-7, F-8, F-9, F-10, F-11, F-12, F-13, F-14, F-15, F-16, F-17, F-18, F-19)*

- R-5.** FOD should design and validate the effectiveness of a program of crew training per a Mars CQRM to meet primary mission objectives and to respond successfully to unforeseen failures. (*F-15, F-16, F-17, F-18, F-19*)
- R-6.** After the Agency makes a final decision on crew size for Mars missions, ESDMD, SOMD, and STMD should continue to update human performance modeling to ensure acceptable workload and the necessary expertise as mission architectures evolve. (*F-3*)

## **9.0 Alternate Technical Opinion(s)**

No alternate technical opinions were identified during the course of this assessment by the NESC assessment team or the NESC Review Board (NRB).

## **10.0 Other Deliverables**

### **NASA-STD-7009 Modeling Standards**

IMPRINT is comprised of four different modeling frameworks, namely 1) Forces, 2) Operations, 3) Equipment and 4) Maintenance. Each of these frameworks address different questions and requires different classes of domain information. To date, no certification has been done for any of the assessment models. However, the framework for certification has been defined in anticipation for its applicability as the models mature and their conclusions are referenced externally.

IMPRINT model certification must address the simulator and the models used by the simulator. The simulator, by definition of being a software application, is certified using NPR 7150\_002D [ref. 70]. The models, input to the simulator, are certified according to NASA-STD-7009A [ref. 71] and NASA-HDBK-7009A [ref. 72].

Simulator certification is dependent on the intended use of the simulator as classified by its software classification. Though the IMPRINT platform is a validated DoD software platform, it is still important to classify the simulator with results to the NASA classification standards due to the fact that NASA has different criteria based on the use of the simulation results.

The higher the classification the more stringent the number of requirements must be met. In Table 90, all six software NPR 7150\_2D classifications (A to F) are defined. The progress of classification is from Class A (human-rated space systems) to Class F (General Purpose Computing).

A preliminary analysis of each software classification to IMPRINT was performed. In principle software classifications C, D, and E may apply. Class C could apply if IMPRINT is used to “verify system-level requirements” such as crew size. Though, at present, crew size is not a system level requirement. Class D could apply if IMPRINT is used to “design reference missions to support mission planning” or “design advanced human-automation systems”. Class E could apply if IMPRINT is used in preliminary phases for mission design.

Appendix C “Requirements Software Mapping” [ref. 70], defines the requirements for each software classification. The link between the certification of the simulator and the models is formalized in requirement [SWE-070]: “... the use validated and accredited software models, simulations, and analysis tools ...can be found in NASA-STD-7009A, Standard for Models and Simulations, NASA-HDBK-7009A, Handbook for Models and Simulations”.

**Table 90. Simulator Software Classification Applicability to IMPRINT Simulations  
[ref. 70]**

Software Classification	Description of Classification	IMPRINT/S-PRINT Relevancy
A	Human-Rated Space Software Systems	
B	Non-Human Space-Rated Software Systems or Large-Scale Aeronautics Vehicles	
C	Mission Support Software or Aeronautic Vehicles, or Major Engineering/Research Facility Software	“..software used to verify system-level requirements associated with Class A, B, or C software by analysis” – though current crew size is NOT a requirement
D	Basic Science/Engineering Design and Research and Technology Software	“..ground software tools that support mission planning for formulation”; “tools used to develop design reference missions to support early mission planning”; “software tools for designing advanced human-automation systems”
E	Design Concept, Research, Technology and General Purpose Software	“software developed to explore a design concept or hypothesis but not used to make decisions for a Class A, B or C systems”
F	General Purpose Computing, Business and IT Software	

NASA-STD-7009A identifies a large number of requirements which should be assessed with respect to the IMPRINT models. A summary of these requirements is provided in Appendix E “M&S Credibility Assessment” as shown in Table 91. The “credibility structure” for assessing the M&S credibility is a sequential process of 1) development, 2) operations and 3) supporting evidence. The M&S Credibility Assessment is still to be determined for the Operations and Forces models in IMPRINT.



**Table 91. Models and Simulation (M&S) Credibility Assessment  
[ref. 71]**

Model Development Phase	7009 Requirement	Test	Impact on IMPRINT Models
Development	[M&S 10] Data Pedigree	“Shall document the relevant characteristics, including data, about the RWS used to develop the model, including its pedigree.”	TBD
Development	[M&S 15] Verification	“Shall verify all models”...to “determine the extent to which an M&S is compliant with its requirements and specifications as detailed in its conceptual models, mathematical models, or other constructs”	TBD
Development	[M&S 17] Validation	“Shall validate all models”... to “determine the degree to which a model or a simulation is an accurate representation of the real world from the perspective of the intended uses of the M&S”	TBD
Operations	[M&S 24] Input Pedigree	“Shall document data used as input to the M&S, including its pedigree”	TBD
Operations	[M&S 19] Uncertainty Characterization	“Shall document any processes and rationale for characterizing uncertainty in reference data”	TBD
Operations	Robustness	“The characteristic whereby the behavior of (result from) an M&S does not change in a meaningful way relative to slight variations in parameters”	TBD
Supporting Evidence	M&S History	“How similar is the current version of the M&S to previous versions, and how similar is the current use of the M&S to previous successful uses?”	TBD
Supporting Evidence	M&S Process/Product Mgt	“How well managed are the M&S processes and products?”	TBD

## **Model and Report Deliverables**

All models and associated data files were electronically transferred to the NESC Technical Fellow for Human Factors in support of future trade space analysis for missions to Mars.

The HAI Operation Model was documented in the HRP Computational Model Repository (CMR). HRP provided support for the precursor S-PRINT plug-in to be incorporated into the IMPRINT platform, and GRC is responsible for maintaining a repository of computational models funded by HRP.

### **11.0 Recommendations for the NASA Lessons Learned Database**

No lessons learned for input to the NASA lessons learned database were identified from this assessment.

### **12.0 Recommendations for NASA Standards, Specifications, Handbooks, and Procedures**

No recommendations for NASA standards, specifications, handbooks, or procedures were identified from this assessment.

### **13.0 Definition of Terms**

Finding	A relevant factual conclusion and/or issue that is within the assessment scope and that the team has rigorously based on data from their independent analyses, tests, inspections, and/or reviews of technical documentation.
Lessons Learned	Knowledge, understanding, or conclusive insight gained by experience that may benefit other current or future NASA programs and projects. The experience may be positive, as in a successful test or mission, or negative, as in a mishap or failure.
Mental Workload	Mental workload in IMPRINT represents the operator mental capacity utilized, associated with different resource channels, when an operator performs tasks. Every task performed by an operator is assigned workload values in applicable resources including visual, cognitive, fine motor, gross motor, auditory, speech, and tactile. Tasks can require several different resources to perform. For example, steering a car requires visual resources (watch where you are going), cognitive resources (decide if you are turning enough), and fine motor resources (moving the steering wheel). When an IMPRINT model is executed, IMPRINT generates a timeline of workload for each operator.
Observation	A noteworthy fact, issue, and/or risk, which may not be directly within the assessment scope, but could generate a separate issue or concern if not addressed. Alternatively, an observation can be a positive acknowledgement of a Center/Program/Project/Organization's operational structure, tools, and/or support provided.
Problem	The subject of the independent technical assessment.

Recommendation      A proposed measurable stakeholder action directly supported by specific Finding(s) and/or Observation(s) that will correct or mitigate an identified issue or risk.

## 14.0 Acronyms and Nomenclature List

ARL HRED	U.S. Army Research Laboratory, Human Research and Engineering Directorate
ASCAN	Astronaut Candidate
AUX	Auxiliary
AVU	Artificial Vision Unit
AVU CCD	Artificial Vision Unit Cursor Control Device
BME	Biomedical Engineer
BMed	Behavioral Medicine
BoC	Basis of Comparison
BORIS	Basic Operational Robotic Instructional System
C&DH	Command & Data Handling System
C&T	Communication and Tracking
CB	Crew Office
CCD	Cursor Control Device
CCDB	Crew Comments Database
CDF	Capability Driven Framework
CDS	Command and Data Handling System
CHC	Crew Health Care
CM-h	Crewmember Hour
CM	Command Module
CMO	Crew Medical Officer
CMR	Computational Model Repository
CNO	Chief of Naval Operations
CNT	Communication and Tracking System
CODA	Collaborative Operations Data Activation
CQRM	Crew Qualifications and Responsibility Matrix
CRONUS	Communications Rf Onboard Network Utilization Specialist
CSA	Canadian Space Agency
CSM	Command/Service Module
DA	Department of the Army
DAC	DEVCOM Analysis Center
DEVCOM	US Army Combat Capabilities Development Command
DoD	Department of Defense
DPC	Daily Planning Conference
DRA	Design Reference Architecture
DRM	Design Reference Mission
DSN	Deep Space Network
DST	Deep Space Transport
ECL	Environmental Control and Life Support
ECLSS	Environmental Control and Life Support System
ECTM	Exploration Crew Time Model
ECW	Emergency, Caution, and Warning

ECWA	Emergencies, Cautions, Warnings, and Advisories
eDPC	Evening Daily Planning Conference
EECOM	Electrical, Environmental, and Consumables Manager
EHP	Extravehicular Activity (EVA) and Human Surface Mobility (HSM) Program
EMC	Evolvable Mars Campaign
Emer	Emergency Response
EMU	Extravehicular Mobility Unit
EPS	Electrical Power System
ESAS	Exploration Systems Architecture Study
ESDMD	Exploration Systems Development Mission Directorate
EV	Extravehicular
EVA	Extravehicular Activity
FCR	Flight Control Room
FOD	Flight Operations Directorate
FOIG	Flight Operations Integration Group
GCA	Ground Control Assist
HAI	Human-Automation Interaction
HAP	Helmet Absorption Pad
HARI	Human-Automation/Robotic Interaction
HBS	Human and Biological Science
HCAAM	Human Capabilities Assessment for Autonomous Missions
HEO	Human Exploration Operations
HEOMD	Human Exploration and Operations Mission
HEOT	Human Exploration Operations Team
HH&PD	Human Health and Performance Directorate
HMTA	Health and Medical Technical Authority
HRP	Human Research Program
HSI	Human System Integration
HSIA	Human-System Integration Architecture
HSM	Human Surface Mobility
HSRB	Human System Risk Board
IA	In Alarm
IFI	Items for Investigation
IMM	Integrated Medical Model
IMPRINT	Improved Performance Research Integration Tool
IROSA	ISS Roll Out Solar Array
ISE	Integration and Systems Engineer
ISO	Inventory Stowage Officer
ISRU	In Situ Resource Utilization
ISS	International Space Station
IT	Information Technology
IV	Intravehicular
JOCAS	Joint Operator Command Auto Sequence
KPP	Key Performance Parameter
L	Lead
LAN	Local Area Network

LCS	Littoral Combat Ship
LEO	Low Earth Orbit
LM	Lunar Module
LPS	Lunar/Planetary Science
M&S	Models and Simulation
MAT	Mars Architecture Team
MAV	Mars Ascent Vehicle
MC	Monte Carlo
MCC	Mission Control Center
MCO	Mars Campaign Office
MCS	Motion Control System
MCS	Monte Carlo Simulation
MDS	Mars Descent System
MDV	Mars Descent Vehicle
MER	Mission Evaluation Room
MI	Mars Infrastructure
MIT	Massachusetts Institute of Technology
MOD	Mission Operations Directorate
MPCV	Multi-Purpose Crew Vehicle
MPSR	Multi-Purpose Support Room
MRD	Manpower Requirements Determination
MRT	Multiple Resource Theory
MS	Mission Specialist
MUIL	Manpower Uncertainties Issues List
NASA-TLX	NASA Task Load Index
NPS	Naval Postgraduate School repeated
NSN	Near Space Network
O	Operator
ODRC	Operational Data Reduction Complex
OGA	Oxygen Generation Assembly
OP	Operations
Ops PLAN	Operations Planner
ORU	Orbital Replacement Unit
OSO MAINT	Operations Support Officer for Maintenance
OSO MECH	Operations Support Officer for Mechanisms
PAF	Productive Availability Factor
PCS	Portable Computer System
PFW	Prepare for Work
PLUTO	Plug-in-plan Utilization Officer
POD	Point of Departure
POE	Projected Operational Environment
POIC	Payload Operations Integration Center
R&R	Remove and Replace
ROBO	Robotics Officer
ROC	Required Operation Capabilities
RT	Recurring Tenets

RWS	Robotic Workstation System
S	Specialist
SA	Situation Awareness
SAO	Strategy and Architecture Office
SAFTE	Sleep, Activity, Fatigue, and Task Effectiveness
SCaN	Space Communications and Navigation
SCE	Signal Conditioning Electronics
SD	Standard Deviation
SE	Science Enabling
SE&I	Systems Engineering and Integration
SEI	Space Exploration Initiative
SM	Service Module
SME	Subject Matter Expert
SNM	Structures and Mechanisms
SOMD	Space Operations Mission Directorate
SPARTAN	Station Power Articulation Thermal Analysis
SPDM	Special Purpose Dexterous Manipulator
S-PRINT	Space Performance Research and Integration Tool
SRK	Skill-Rule-Knowledge
SSRMS	Space Station Remote Manipulator System
STMD	Space Technology Mission Directorate
TCS	Thermal Control System
TH	Transportation and Habitation
TXTL	Total Time Loss
UHF	Ultra-high Frequency
VSE	Vision for Space Exploration
VVO	Visiting Vehicle Officer
WPC	Weekly Planning Conference

## 15.0 References

1. Panontin, T. L., Wu, S. C., Parisi, M. E., McTigue, K. R., & Vera, A. H. (2021) *Human-Systems Integration Architecture Needs Analysis: On-Board Anomaly Resolution During Autonomous Operations*. NASA's Human Research Program Technical Report.
2. Lippert, A.F., Scripture, B. L., "A Review of Department of Defense Manpower Analysis to Inform Crew Size Determination for NASA's Manned Missions to Mars" (Master of Human System Integration Capstone). Naval Postgraduate School, Monterey, CA. (2021)
3. Sushereba et al. (2019). *A Tradespace Framework for Evaluating Crewing Configurations for Future Vertical Lift*. Proceedings of the Human Factors and Ergonomics Society 2019 Annual Meeting.
4. Militello et al. (2019). *Towards and Optimally Crewed Future Vertical Lift Vehicle: Crewing Strategy and Recommendations (Phase 2 Report)*. Prepared for U.S. Army Combat Capabilities Development Command Aviation & Missile Center, Huntsville, AL.
5. NASA (2020). *Human System Risk Management Plan, Rev. B*. NASA, Houston, TX, JSC-66705.
6. Melroy, P. (2022) *Moon to Mars Objectives*. NASA publication.

7. PARC/CAST Flight Deck Automation Working Group. (2013). *Operational use of flight path management systems. Final Report of the Performance-based operations Aviation Rulemaking Committee/Commercial Aviation Safety Team Flight Deck Automation Working Group*. Washington, DC: Federal Aviation Administration.
8. Hollnagel, E., Wears, R. L., Braithwaite, J. (2015) *From Safety-I to Safety-II: A White Paper*. The Resilient Health Care Net: Published simultaneously by the University of Southern Denmark, University of Florida, USA, and Macquarie University, Australia.
9. Chappell, MB, Chai, PR, & Rucker, MA (2023) Mars Communications Disruption and Delay. White Paper. <https://www.nasa.gov/moontomarsarchitecture-whitepapers/> or <https://ntrs.nasa.gov/citations/20230012950>
10. Department of Defense (DoD). (2016, February 1). Manpower planning and human systems integration. In Defense acquisition guidebook. <https://www.dau.edu/pdfviewer?Guidebooks/DAG/DAG-CH-5-Manpower-Planning-and-Human-Systems-Integration.pdf>
11. Chief of Naval Operations (CNO). (2015, June 24). Navy total force Manpower policies and procedures (OPNAVINST 1000.16L). Department of the Navy. <https://www.secnav.navy.mil/doni/Directives/01000 Military Personnel Support/01-01 General Military Personnel Records/1000.16L With CH-3.pdf>
12. Navy Manpower Analysis Center (NAVMAC). (2000, April). Navy Total Force Manpower Requirements Handbook. Department of the Navy. <https://www.mynavyhr.navy.mil/Portals/55/NAVMAC/Documents/ReqHdBk.pdf?ver=o3-ye8DyNkuFJPX1Mq4xsw%3d%3d>
13. Department of the Army (DA). (2006, February 8). Manpower management (AR 570-4). [https://armypubs.army.mil/epubs/DR\\_pubs/DR\\_a/pdf/web/r570\\_4.pdf](https://armypubs.army.mil/epubs/DR_pubs/DR_a/pdf/web/r570_4.pdf)
14. Secretary of the Air Force (SAF). (2019, August 29). Manpower and organization (AFI 38-101). Department of the Air Force. [https://static.e-publishing.af.mil/production/1/af\\_a1/publication/afi38-101/afi38-101.pdf](https://static.e-publishing.af.mil/production/1/af_a1/publication/afi38-101/afi38-101.pdf)
15. Secretary of the Air Force (SAF). (2019, September 4). Manpower and organization: standard work processes and procedures (AFM 38-102). Department of the Air Force. [https://static.e-publishing.af.mil/production/1/af\\_a1/publication/afman38-102/afman38-102.pdf](https://static.e-publishing.af.mil/production/1/af_a1/publication/afman38-102/afman38-102.pdf)
16. Hollins, R. (2014) USN Manpower Determination Decision Making: A Case Study Using IMPRINT Pro to Validate the LCS Core Crew Manning Solution. Naval Postgraduate School. Monterey, CA.
17. Shattuck, N. & Matsangas, P. (2015) Optimization of Shipboard Manning Levels Using IMPRINT Pro Forces Model. Naval Postgraduate School. Monterey, CA.
18. Free, J., Koerner, C., Merancy, N. (2023). *M2M Architecture Process Overview*. Presented at NASA's Moon to Mars Architecture Workshop.
19. Militello et al. (2018). *Toward an Optimally Crewed Future Vertical Lift Vehicle: Overview of the Envisioned World, Core Missions and Pertinent Technology (Phase I Report)*. Prepared for U.S. Army Aviation & Missile Research, Development and Engineering Center, Huntsville, AL.
20. Rucker, M. (2022). *Representative Mars Mission Communication Disruption and Delay Analysis*. NASA internal memo25, 26] XM-M1622022.

21. Schier and Baldwin (2022 and 2024). NASA SCan Project personnel, personal communication.
22. Rucker, M. A., Craig, D. A., Burke, L. M., Chai, P. R., Chappell, M. B., Drake, B. G., ... & Troutman, P. A. (2022, March). NASA's Strategic Analysis Cycle 2021 (SAC21) Human Mars Architecture. In 2022 IEEE Aerospace Conference (AERO) (pp. 1-10). IEEE. <https://ntrs.nasa.gov/citations/20210026448>
23. Dempsey, D. L. (2013, May). TEE/Audit Policy. Presented to the Flight Operations Integration Group (FOIG), NASA Johnson Space Center, Houston, TX.
24. Holden, K., Munson, B., Russi-Vigoya, N., Dempsey, D., Adelstein, B. (2019). Human Capabilities Assessment for Autonomous Missions (HCAAM) Phase II: Development and Validation of an Autonomous Operations Task List Final Report. Internal NASA Report: unpublished.
25. Allender, L., Lockett, J., Kelley, T., Salvi, L., Mitchell, D., Headley, D., Promisel, D., Richer, C. (1995). Verification, Validation, and Accreditation of a Soldier-system Modeling Tool, In Proceedings of the Human Factors and Ergonomics Society Annual Meeting, October 1995, Vol. 39 No 18, 1219-1223.
26. Hart, S., & Wickens, C. D. (2008). Cognitive Workload. NASA human integration design handbook (HIDH). Washington, DC: National Aeronautics and Space Administration. <https://www.nasa.gov/organizations/ochmo/human-integration-design-handbook/>
27. Little, R., Dahl, S., Plott, B., Wickens, C., Powers, J., Tillman, B., Davilla, D., Hutchins, C. (1993). Crew reduction in armored vehicles ergonomic study (CRAVES) final report (No. ARL-CR-80). Hopkins, MN: Alliant Techsystems, Inc.
28. Wickens, C. D. (2002). Multiple resources and performance prediction. *Theoretical Issues in Ergonomics Science*, 3(2), 159-177.
29. Multilateral Advanced/Increment-specific Training Plan (MA/ITP). NASA Internal Document. Houston. TX
30. Mitchell, D. and Samms, C. (2011). Predicting the Consequences of Workload Management Strategies with Human Performance Modeling. MODSIM World 2010 Conference Expo, NASA Document ID 20110012092.
31. Yerkes, R. M. & Dodson, J. D. (1908). The relation of strength of stimulus to rapidity of habit formation. *Journal of Comparative Neurology and Psychology*, 18,459-482.
32. Gabriel, R. F. (2003). What engineers and managers need to know about human factors. SAE International.
33. Stokes, A. F., & Kite, K. (2017). *Flight stress: Stress, fatigue and performance in aviation*. Routledge.
34. Kantowitz, B. H. and Casper, P. A. 1988). Human Workload in Aviation, in Wiener, E. L., & Nagel, D. C. (Eds.). *Human factors in aviation*. Academic Press.
35. NASA. "NASA-STD-3001 Technical Brief - Cognitive Workload." NASA.gov <https://www.nasa.gov/wp-content/uploads/2023/03/cognitive-workload-technical-brief-ochmo-1.pdf>.
36. Smith, M. (2020). *Human Exploration and Operations (HEO) Systems Engineering and Integration (SE&I) Decision Memorandum Mars Mission Duration Guidance for Human*



*Risk Assessment and Research Planning Purposes.* HEO-DM-1002.

<https://ntrs.nasa.gov/citations/20210025427>

37. A. Valinia et al. (2022). *Safe Expeditions Beyond LEO*. NASA/TM–20220002905. NESC-RP-20-01589.
38. Valinia, A., Allen, J. R., Francisco, D. R., Minow, J. I., Pellish, J. A., & Vera, A. H. (2022). Safe human expeditions beyond low Earth orbit (LEO) NESC-RP-20-01589, NASA/TM-20220002905. <https://ntrs.nasa.gov/citations/20220002905>
39. Rasmussen, J. (1983). Skills, rules, and knowledge; signals, signs, and symbols, and other distinctions in human performance models. *IEEE transactions on systems, man, and cybernetics*, (3), 257-266.
40. Gore, B.F., Vera, A., Marquez, J., Holden, K., Amick, R., Dempsey, D., & Munson, B. (2021). Evidence Report: Risk of Inadequate Human-System Integration Architecture (HSIA). NASA. [https://ntrs.nasa.gov/api/citations/20210012912/downloads/HSIA\\_Evidence\\_Report\\_Final\\_04-27-21.pdf](https://ntrs.nasa.gov/api/citations/20210012912/downloads/HSIA_Evidence_Report_Final_04-27-21.pdf)
41. Woods, D. D., & Dekker, S. (2000). Anticipating the effects of technological change: A new era of dynamics for human factors. *Theoretical issues in ergonomics science*, 1(3), 272-282. <https://doi.org/10.1080/14639220110037452>
42. Chang, M. L., & Marquez, J. J. (2018). Human-automation allocations for current robotic space operations: space station remote manipulator system. NASA Technical Memorandum, NASA/TM—2018–220042. <https://ntrs.nasa.gov/citations/20200003149>
43. Aziz, S. (2013). Development and verification of ground-based tele-robotics operations concept for Dextre. *Acta Astronautica*, 86, 1-9. <https://doi.org/10.1016/j.actaastro.2011.11.004>
44. Currie, N. J., & Peacock, B. (2002). International Space Station robotic systems operations—A human factors perspective. *Proceedings of the human factors and ergonomics society annual meeting*, 46(1), 26-30. <https://doi.org/10.1177/154193120204600106>
45. Sebok, A., Wickens, C., Sargent, R., Clegg, B. and Jones, T. (2015) Space Performance Research Integration Tool (S-PRINT): Development and Validation of a Model-Based Tool to Predict, Evaluate and Mitigate Excessive Workload Effects, Year 3 Status Report / Final Report, NASA Grant NNX12AE69G.
46. Station Program Implementation Plan (SPIP) Volume 9, Section 5.3.2.2.1.2.3, Version 23. NASA, Houston, TX
47. NASA-STD-3001 Vol. 1. 3.1.6.1 Crew Medical Officers Quantity [V1 3006] The program(s) shall train a minimum of two crewmembers per vehicle/platform as Crew Medical Officers (CMOs).
48. Dempsey, D. L., Barshi, I., Landon, L., Jensen, M., Fard, B., Simmons, T. S., Nyberg, K., & Hansen, J. (2018). *Training for NASA's Gateway and Deep Space Transport (DST) Missions: FOD Stakeholder Concerns and Top Priority Workshop*. Internal NASA Report: unpublished.
49. Barshi, I. & Dempsey, D. (2016). *Evidence Report: Risk of Performance Errors Due to Training Deficiencies*. NASA, Houston. TX. (JSC-CN-35755) <https://ntrs.nasa.gov/citations/20160003868>

50. Sonoda, M. (2016). *NASA's Human Spaceflight Training Reduction Effort*. Internal NASA report, unpublished.
51. NASA (2022). *ISS Crew Training Durations, Training Branch, The Year 2022*. Internal NASA report, unpublished.
52. Ericsson, K. A. (2009) *Development of Professional Expertise*. Cambridge University Press. New York, N.Y.
53. Landon, L. B. (2022) *Risk of Performance and Behavioral Health Decrements Due to Inadequate Cooperation, Coordination, and Psychosocial Adaptions within a Team*. NASA, Houston, TX.
54. Dev, S.I., Whiting, S.E., Nelson, G.A., Dotson, V., Mulavara, A., Schorn, J.M., Williams, T.J. (Under Review). *Risk of Adverse Cognitive and Behavioral Conditions and Psychiatric disorders*. Evidence Report. NASA Johnson Space Center.
55. Landon, L. B., Rokholt, C., Slack, K. J., & Pecena, Y. (2017). Selecting astronauts for long-duration exploration missions: Considerations for team performance and functioning. *REACH—Reviews in Human Space Exploration*, 5, 33–56.
56. Bell, S. T., Brown, S.G., Abben, D. R., Outland, N.B. (2015) Team composition issues for future space exploration: a review and directions for future research. *Aerospace Med Hum Perf*, 86(6) 548-556.
57. Bell, S. T., Nyberg, B., Chackoria, J., Vazquez, M., Vinokhodova, A., Gushin, V., DeChurch, L. A., Contractor N. (2021) *Psychological distance as a predictor of viable relationships and team performance in isolated and confined environments*. Poster presented at the 2021 NASA Human Research Program Investigators' Workshop, virtual.
58. Mathieu, J. E., Luciano, M. M., D'Innocenzo, L., Klock, E. A., LePine, J. A. (2019) The development and construct validity of a team processes survey measure. *Org Res Methods* 1:1094428119840801.
59. Scheuring, R. A., Jones, J. A., Novak, J. D., Polk, J. D., Gillis, D. B., Schmid, J., ... & Davis, J. R. (2008). The Apollo Medical Operations Project: Recommendations to improve crew health and performance for future exploration missions and lunar surface operations. *Acta Astronautica*, 63(7-10), 980-987.
60. Salas, E., DiazGranados, D., Klein, C., Burke, C. S., Stagl, K. C., Goodwin, G. F., Halpin, S. M. (2008) Does team training improve team performance? A meta-analysis. *Hum Factors* 50(6):903-933 doi:10.1518/001872008X375009.
61. Stuster et al. (2018). *Generalizable Skills and Knowledge for Exploration Missions* NASA/CR-2018-220455.
62. Burke, C. S., Driskell, T., Driskell J., Salas, E. (2020). *Team Roles Matter in Space Exploration: Insights and Prescriptive Guidance*. Presented at the 2020 NASA Human Research Program Investigators' Workshop, Galveston, TX.
63. Duke, M. & Budden, N. (1992) "Results, Proceedings and Analysis of the Mars Exploration Workshop," JSC-26001, NASA Johnson Space Center, Houston, Texas, August 1992.
64. Drake, B. G. & Watts, K. D. eds. (2014) *Human Exploration of Mars Design Reference Architecture 5.0 Addendum #2*, NASA Johnson Space Center, Houston, TX. NASA/SP-2009-566-ADD2.

65. Hoffman, S. J., & Kaplan, D. I. eds (1997). *Human exploration of Mars: The Reference Mission on the NASA Mars Exploration Study Team*. NASA Special Publication 6107. Houston, TX.
66. Pendergraft, J. G., Carter, D. R., Tseng, S., Landon, L. B., Slack, K. J., Shuffler, M. L. (2019) Learning from the past to advance the future: The adaptation and resilience of NASA's spaceflight multiteam systems across four eras of spaceflight. *Frontiers in Psychology* 10:1633.
67. Dempsey, R. ed. (2018) *The International Space Station Operating an Outpost in the New Frontier*. NASA Johnson Space Center, Houston, TX.
68. Mulhearn, T., McIntosh, T., Gibson, C., Mumford, M. D., Yammarino, F. J., Connelly, S., Day, E. A., Vessey, B (2016) Leadership for long-duration space missions: A shift toward a collective approach. *Acta Astronaut* 129:466–476.
69. Russell, M., DeChurch, L., Bell, S., Emery, A., & Contractor, N. (2022, February). The Right Size: Designing Autonomous Teams to go the Distance. In *2022 Human Research Program Investigators' Workshop (HRP IWS 2022)*, Galveston, TX.
70. NPR 7150.2D "NASA Software Engineering Requirements" 20220308  
[https://nodis3.gsfc.nasa.gov/npg\\_img/N\\_PR\\_7150\\_002D\\_/N\\_PR\\_7150\\_002D\\_.pdf](https://nodis3.gsfc.nasa.gov/npg_img/N_PR_7150_002D_/N_PR_7150_002D_.pdf).
71. NASA-STD-7009A "Standard for Models and Simulations" 20160713  
[https://standards.nasa.gov/sites/default/files/standards/NASA/w/CHANGE-1/1/nasa\\_std\\_7009a\\_change\\_1.pdf](https://standards.nasa.gov/sites/default/files/standards/NASA/w/CHANGE-1/1/nasa_std_7009a_change_1.pdf)
72. NASA-HDBK-7009A "NASA Handbook for Models and Simulations: An Implementation Guide for NASA-STD-7009A" 20190508  
<https://standards.nasa.gov/sites/default/files/standards/NASA/A/0/nasa-hdbk-7009a.pdf>
73. Mattfeld, B., Stromgren, C., Shyface, H., Cirillo W., & Goodliff K. (2015) Developing a Crew Time Model for Human Exploration Missions to Mars. IEEE.

## Section 6.2 References

1. *Human Mars Mission Design – The Ultimate Systems Challenge* (Connolly et al. 2017)  
<https://ntrs.nasa.gov/api/citations/20170008879/downloads/20170008879.pdf>
2. *The Mars Project* by Wernher von Braun (1948)  
<https://archive.org/details/marsproject0000vonb>
3. *The Exploration of Mars* by Wernher von Braun and Willy Ley (1956)  
<https://archive.org/details/explorationofmar0000will/page/n7/mode/2up>
4. *Humans to Mars: Fifty Years of Mission Planning, 1950-2000* by David S. F. Portree  
<https://history.nasa.gov/monograph21.pdf>
5. *Eyes on the Red Planet: Human Mars Mission Planning, 1952-1970* by Annie Platoff (NASA JSC 2001) <https://escholarship.org/uc/item/0dx7866r>
6. *A Study of Manned Nuclear-Rocket Missions to Mars* (NASA Lewis, 1961)  
[https://archive.org/details/nasa\\_techdoc\\_19630041958](https://archive.org/details/nasa_techdoc_19630041958)
7. *Proceeding of the symposium on manned planetary missions 1963/1964 status* (MSFC, 1964) <https://ntrs.nasa.gov/api/citations/19640017065/downloads/19640017065.pdf>

8. *Apollo: The Race to the Moon* by Charles Murray and Catherine Cox (1989) <https://archive.org/details/apollo-the-race-to-the-moon>
9. *Exploration studies technical report, FY1988 status. Volume 1: Technical summary* (NASA, 1988) <https://ntrs.nasa.gov/api/citations/19890007335/downloads/19890007335.pdf>
10. *Exploration studies technical report. Volume 2: Studies approach and results* (NASA, 1988) <https://ntrs.nasa.gov/api/citations/19890007336/downloads/19890007336.pdf>
11. *Mars Exploration Study Workshop II* (NASA, 1993) <https://ntrs.nasa.gov/api/citations/19940017410/downloads/19940017410.pdf>
12. *Human Exploration of Mars: The Reference Mission of the NASA Mars Exploration Study Team* (NASA, 1997) [https://spacecraft.ssl.umd.edu/design\\_lib/NASA-SP6107.Mars\\_DRM.pdf](https://spacecraft.ssl.umd.edu/design_lib/NASA-SP6107.Mars_DRM.pdf)
13. *HEOT Operations Concept Definition for the Human Exploration of Mars* (NASA, 2000)
14. *The Mars Surface Reference Mission: A Description of Human and Robotic Surface Activities* (Hoffman, 2001) <https://space.nss.org/wp-content/uploads/2001-NASA-Mars-Surface-Reference-Mission.pdf>
15. *Antarctic Exploration Parallels for Future Human Planetary Exploration: A Workshop Report* (Hoffman, 2002). <https://ntrs.nasa.gov/api/citations/20020042034/downloads/20020042034.pdf>
16. NASA's Exploration Systems Architecture Study final report November 2005 [https://www.nasa.gov/pdf/140649main\\_ESAS\\_full.pdf](https://www.nasa.gov/pdf/140649main_ESAS_full.pdf)
17. *Human Exploration of Mars Design Reference Architecture 5.0* (NASA, 2009) [https://www.nasa.gov/pdf/373665main\\_NASA-SP-2009-566.pdf](https://www.nasa.gov/pdf/373665main_NASA-SP-2009-566.pdf)
18. "Evolvable Mars Campaign Development" (Hoffman and Toups 2016) [https://researchinfrastructureoutreach.com/wp-content/uploads/2018/05/2016\\_NASAemcDev.pdf](https://researchinfrastructureoutreach.com/wp-content/uploads/2018/05/2016_NASAemcDev.pdf)
19. *Preparing for Mars: Evolvable Mars Campaign "Proving Ground" Approach* (Bobskill et al., 2015) <https://ntrs.nasa.gov/api/citations/20150009470/downloads/20150009470.pdf>
20. *Mars Architecture Technology Drivers Overview* (Cirillo et al., 2016) [https://www.nasa.gov/sites/default/files/atoms/files/nac\\_wcirillo\\_mars\\_architecture\\_nov2016\\_tagged.pdf](https://www.nasa.gov/sites/default/files/atoms/files/nac_wcirillo_mars_architecture_nov2016_tagged.pdf)
21. *Comparison of Human Exploration Architecture and Campaign Approaches* (Goodliff et al., 2015) <https://arc.aiaa.org/doi/pdf/10.2514/6.2015-4413>
22. *Generalizable Skills and Knowledge for Exploration Missions* (Stuster et al., 2019) <https://ntrs.nasa.gov/api/citations/20190023004/downloads/20190023004.pdf>
23. *NASA's Strategic Analysis Cycle 2021 (SAC21) Human Mars Architecture* (Rucker et al., 2021) <https://ntrs.nasa.gov/citations/20210026448>